

Service Manual



Tektronix

VM700T
Video Measurement Set
070-9630-05

Table of Contents

General Safety Summary	xv
Service Safety Summary	xvii
Preface	xix
Contents of the Manual	xix

Specification

Electrical Characteristics	1-1
Physical Characteristics	1-4
Power Requirements	1-4
Environmental	1-4
Power Line Conditioner for Option A1 and A2 Power Cords	1-10
PAL Measurement Specifications	1-12
Measure Mode	1-12
Auto Mode	1-17
NTSC Measurement Specifications	1-21
Measure Mode	1-21
Auto Mode	1-26
Audio Option 40, Option 41, and Option 42 Specifications	1-31
Automatic Audio Test Specifications	1-31
Audio Analyzer Specifications	1-32
Audio Spectrum Specifications	1-34
Multitone Analyzer Specifications	1-35
A/V Timing Specifications (Option 42)	1-36
Option 48 GPIB Specification	1-36
Option 1S SDI Specification	1-38

Operating Information

Installation	2-1
Unpackaging	2-1
Power Requirements	2-1
Changing Line Voltage Range and Fuse	2-2
Power Cord	2-2
Power Line Conditioner Accessory	2-2
Installing the Power Line Conditioner	2-3
Power On Diagnostics	2-4
Calibrating the Touch Screen	2-5
Setting the Power On Mode	2-7
Measurement Set Operating Modes	2-8
Waveform Mode	2-8
Vector Mode	2-9
Measure Mode	2-9
Picture Mode	2-9
Auto Mode	2-9
User-Programmable Functions	2-10
Hardcopy	2-10
Remote Operation	2-10

Front Panel Controls	2-11
Touch Screen	2-11
Keypad	2-12
Control Knob	2-14
Equipment/Signal Sources Required	2-15
Bandwidth	2-15
Connecting Inputs and Outputs	2-15
Rear Panel and Connections	2-16
Equipment/Video Signal Sources Required	2-18
Connecting Audio Option 40 to a Source	2-19
Input Connector Pin Assignments	2-19
Connecting Audio Option 41 to a Source	2-20
Option 41 Audio Signal Interconnection Cable	2-20
GPIB Option 48 Signal Connections and Rear Panel	2-21
GPIB Indicator LED	2-21
SDI Option 1S Rear Panel Connections	2-22

Theory of Operation

Overview of The VM700T System	3-1
Module Functional Description	3-3
Analog Input Board (A1)	3-3
Loop-Through Inputs	3-3
Mode Control	3-3
Clamped Input Amplifiers	3-3
Clamp and Bias Generator	3-3
Channel Selection	3-3
Differential Amplifier	3-5
Dynamic Offset Generator and Offset Amplifier	3-5
Variable-Gain Amplifier	3-5
Dither Generator and Dither Amplifier	3-5
Calibration DAC	3-5
Sync Selection	3-6
DVM Selection and DVM	3-6
The Genlock Board (A2)	3-7
Sync Stripper	3-7
Crystal Oscillator	3-7
FH Generator	3-9
Phase-Locked Loop (PLL)	3-9
Divide-by-2 Frequency Divider	3-9
Frame Decoder	3-9
Frame Rate Synthesizer	3-9
Stripped Sync Processing	3-9
Output Generator	3-10
Control	3-10
Status	3-10

The Analog-to-Digital (ADC) Board (A3)	3-11
+2.5 V and -2.5 V Regulators	3-11
Signal Conditioning Amplifier	3-11
A/D Converter	3-11
Buffer	3-11
Output Latch	3-11
Line and Frame Pulse Pipeline	3-13
Overrange Detector	3-13
Sample Clock	3-13
Filter Switch Board (A4)	3-14
Filter Select and Control	3-14
Slot 0	3-14
Slots 1-5	3-14
Output Amplifier	3-14
CPU Board (A5)	3-16
System Bus	3-16
EPROM	3-17
NVRAM	3-17
NVRAM SIMM	3-17
Flash EPROM	3-17
DRAM	3-17
Real-Time Clock	3-17
Display ASIC and VRAM	3-17
Front Panel Processor	3-18
CPU I/O Board (A20)	3-18
Serial Ports	3-18
Parallel Port Interface	3-19
32-Bit Counter	3-19
Connector	3-19
Data Acquisition/Controller Board (A18)	3-20
Video Data and Clock Inputs	3-20
FIFO/Demultiplexor	3-20
Acquisition Control	3-20
Acquisition Clock	3-20
Data Bus Interface	3-20
Data Acquisition Memory (Static RAM)	3-20
Min-Max ASIC	3-20
Controller Section	3-22
Bus Buffers	3-22
Controller ASIC	3-22
Address Decoding	3-22
Output Latches and Analog Input Board Interface	3-22
Clamp Counters	3-22
Status Counter	3-24
ECL-To-TTL Conversion	3-24
Data and Address Latches onto the BCD0-12 Bus	3-24
Trigger RAM	3-24
Sequencer (State Machine)	3-24
Dynamic Settings	3-25
Front Panel Board (A10A1)	3-27

Keypad Board (A10A2)	3-28
Control Knob	3-28
Push Buttons	3-28
LEDs	3-28
Main Interconnect Board (Left and Right) (A11)	3-29
Picture Monitor (A14)	3-29
Video Amplifier	3-29
+12 V and + 5 V Supplies	3-29
Vertical Deflection	3-29
Horizontal Deflection	3-30
High Voltage	3-31
Trace Rotation	3-31
Power Supply (A15)	3-31
Input Power Rectifier	3-31
Housekeeping Power Supply	3-31
Inverter Switching Circuit	3-31
+12 V and 15 V Regulators	3-32
Alarm Sensing	3-33
Alarm Logic	3-33
Fan Drive	3-33
Option 40 Audio Measurements	3-33
Audio Processor Board (A12)	3-33
Audio Processor Interface	3-34
Address Decoders	3-34
Bus Buffers	3-34
Address Buffers	3-34
Interrupt Generator/Status Port	3-35
Interrupt Generator	3-35
Data Buffers	3-35
Reset Register	3-35
DSP Processor and I/O Interface	3-35
Oscillator	3-35
Communication Ports	3-35
Audio Data Register	3-36
CPU Access Disable	3-36
Static RAM	3-36
P Memory	3-36
X-Data and Y-Data Memory	3-36
Program Loading	3-36
Control Lines	3-36
Audio Analog Board (A13)	3-37
Input Amplifiers	3-37
Signal Input	3-37
Stepped Attenuator	3-37
Input Amplifier	3-37
400 Hz Notch Filter/DAC Output	3-39
Notch Filter Operation	3-39
DAC Output	3-39
Option 40 A/D Converter	3-40
Input Clamp	3-40
CH 2 (and CH 1) Amplifier	3-40
A/D Converter	3-40

Audio Board Control	3-40
Opto-Isolators	3-40
Synchronizer	3-41
Counter/Decoder	3-41
Control Register	3-41
Master Oscillator and Clock Divider	3-41
Calibration DAC	3-42
Floating Power Supply	3-42
Grounds	3-42
Option 41 Audio Analog Board	3-42
6 Balanced Input Selector	3-42
Option 48 GPIB Interface Board (A19)	3-44
Option 1S Serial Digital Measurements	3-47
SDI Rear Panel Interface Assembly	3-47
SDI Board	3-47

Performance Verification

Self Diagnostics	4-1
Test Equipment Required	4-6
System Verification Procedures	4-7
Audio Option Verification Procedure	4-13
Test Equipment Required	4-13
Audio Option 40 Verification Procedure	4-15
Check Level Measurement Accuracy and Flatness	4-15
Specifications Checked	4-15
Option 40 Level Accuracy and Flatness	4-15
Check Distortion and Distortion Measurement Accuracy	4-17
Specification Checked	4-17
Option 40 Distortion Measurement Accuracy	4-17
Check Frequency and Phase Measurement Accuracy	4-18
Specifications Checked	4-18
Option 40 Frequency Accuracy and Channel Phase Difference	4-18
Audio Option 41 Triple-Input Verification Procedure	4-19
Configuring Source Selection Audio	4-19
Check Level Measurement Accuracy and Flatness	4-20
Option 41 Level Accuracy and Flatness	4-20
Check Distortion and Distortion Measurement Accuracy	4-22
Option 41 Distortion Measurement Accuracy	4-22
Check Frequency and Phase Measurement Accuracy	4-23
Option 41 Frequency Accuracy and Channel Phase Difference	4-23
SDI Option 1S Performance Verification	4-25
Preliminary Setup	4-26
SDI Analog Ref Input	4-27
Eye Diagram Application	4-28
Jitter Application	4-30
Interchannel Timing Application	4-34
SDI Output	4-35

Adjustment Procedure

Test Equipment Required	5-1
System Adjustment Procedures	5-2
Extended Adjustment Procedure	5-15
Option 1S Adjustment Procedure	5-22

Maintenance

Servicing Preparation	6-1
Inspection and Cleaning	6-4
Repackaging the Instrument	6-5
Repackaging	6-5
Removal and Replacement Instructions	6-6
VM700T Rack Mounting Instructions	6-44
Troubleshooting Procedures	6-49
Troubleshooting Techniques	6-50
Isolating Operational Faults	6-51
Diagnostics	6-55
Troubleshooting the Power Supply and CRT Display	6-90
Troubleshooting Option 40 and Option 41 (Audio)	6-95
Troubleshooting Option 48 (GPIB)	6-99
Troubleshooting Option 1S (SDI)	6-100
SDI Option Diagnostics	6-104

Options

Standard Options (Option 01 and Option 11)	7-1
Application Options (Option 1G, Option 20, Option 21, Option 30, Option 42)	7-1
Audio Options (Option 40 and Option 41)	7-3
Serial Digital Interface (Option 1S)	7-4
GPIB Interface (Option 48)	7-4
White Phosphor CRT (Option 74)	7-4
Cabinet and Mounting Options (Option 1C, VM7FR1, VM7FC1)	7-5
Auxiliary Software Options (VMBKUP, VMT, VMREMGR)	7-5
Optional Accessories	7-5
Power Cord Options	7-6

Replaceable Electrical Parts

Diagrams

Block Diagram	9-1
Interconnection Diagram	9-1

Replaceable Mechanical Parts

Parts Ordering Information	10-1
Using the Replaceable Mechanical Parts List	10-1

List of Figures

Figure 2-1: Power line conditioner with a rackmounted VM700T .	2-3
Figure 2-2: VM700T Startup menu	2-5
Figure 2-3: Touch screen calibration (display)	2-6
Figure 2-4: Touch screen calibration (panel)	2-6
Figure 2-5: Panel calibration values	2-7
Figure 2-6: Diagnostic configuration menu	2-7
Figure 2-7: Set diagnostics power up mode menu	2-8
Figure 2-8: The VM700T Video Measurement Set front panel	2-11
Figure 2-9: Measurement set keypad	2-12
Figure 2-10: VM700T Video Measurement Set rear panel	2-16
Figure 2-11: Video signal input connectors	2-18
Figure 2-12: Cables and connectors supplied with Audio Option 40	2-19
Figure 2-13: Option 40 connectors and pin assignments	2-19
Figure 2-14: Option 41 input connector pin locations	2-20
Figure 2-15: GPIB board rear panel	2-21
Figure 2-16: VM700T rear panel with Option 1S installed	2-23
Figure 2-17: Option 1S rear panel	2-23
Figure 3-1: Analog input board (A1) block diagram	3-4
Figure 3-2: Genlock board (A2) block diagram	3-8
Figure 3-3: ADC board block diagram	3-12
Figure 3-4: Filter switch board (A4) block diagram	3-15
Figure 3-5: CPU board block diagram	3-16
Figure 3-6: CPU I/O board block diagram	3-18
Figure 3-7: Acquisition circuitry block diagram	3-21
Figure 3-8: Controller section block diagram	3-23
Figure 3-9: Dither generator 64-step dither waveform	3-26
Figure 3-10: Front panel board block diagram	3-27
Figure 3-11: Keypad board (A10A2) block diagram	3-28
Figure 3-12: Picture Monitor simplified block diagram	3-30
Figure 3-13: Simplified block diagram of the power supply	3-32
Figure 3-14: Audio Processor block diagram	3-34
Figure 3-15: Audio Analog block diagram	3-38
Figure 3-16: Audio Analog block diagram	3-43
Figure 3-17: GPIB board location in the measurement set	3-44
Figure 3-18: Block diagram of the GPIB interface option board . . .	3-45
Figure 3-19: GPIB rear panel arrangement	3-46
Figure 3-20: Option 1S block diagram	3-48

Figure 4-1: VM700T Startup Menu	4-1
Figure 4-2: Instrument run modes menu	4-2
Figure 4-3: Configure directory	4-3
Figure 4-4: Power-up diagnostics selection display	4-4
Figure 4-5: Diagnostic selection file showing an unselected choice .	4-4
Figure 4-6: Option 40 cable connections, level accuracy and flatness check	4-16
Figure 4-7: Option 40 cable connections, distortion measurement accuracy check	4-17
Figure 4-8: Option 41 cable connections, level accuracy and flatness check	4-21
Figure 4-9: Option 41 cable connections, distortion measurement accuracy check	4-22
Figure 5-1: Adjustment locations	5-5
Figure 5-2: VM700T startup menu	5-11
Figure 5-3: Display monitor centering adjustments	5-12
Figure 5-4: Touch screen calibration (display)	5-12
Figure 5-5: Touch screen calibration (panel)	5-13
Figure 5-6: Panel calibration values	5-13
Figure 5-7: Example gain-phase analyzer flatness waveforms	5-18
Figure 5-8: VM700T startup menu	5-21
Figure 5-9: Instrument run modes menu	5-21
Figure 5-10: Loosening the right-side cover	5-23
Figure 5-11: Cable requirements for adjusting the Cable Meter ...	5-26
Figure 5-12: Location of CPU board dip switch and SDI board test point and adjustment resistor	5-28
Figure 5-13: Adjusting the eye crossing horizontal position	5-30
Figure 5-14: Adjusting the rising edge of the SDI Eye Diagram application	5-31
Figure 6-1: Locating the major standard assemblies	6-7
Figure 6-2: Removing a cover panel	6-8
Figure 6-3: Removing the left card cage center support	6-10
Figure 6-4: Installing the I/O board in the card cage	6-10
Figure 6-5: Locating audio option boards in the left-side card cage	6-11
Figure 6-6: Orientation of the cable adapter collar	6-13
Figure 6-7: Option 41 (Triple-Input Audio) input connector pin locations	6-13

Figure 6-8: Ferrite forms installed on the Option 41 interconnection cable	6-14
Figure 6-9: Loosening the screws on the right card cage retainer ..	6-16
Figure 6-10: Location of right card cage circuit boards	6-17
Figure 6-11: Acquisition Memory board (A18) cables	6-19
Figure 6-12: SDI board (A22) cable connections	6-21
Figure 6-13: Installing the SDI Rear Panel Interface (A23) assembly	6-22
Figure 6-14: Disconnecting the Analog Input board connectors ...	6-24
Figure 6-15: Removing screws from the signal input connector plate	6-25
Figure 6-16: Removing the Genlock board	6-27
Figure 6-17: Removing the ADC board	6-29
Figure 6-18: Removing the Filter Switch board	6-31
Figure 6-19: Locating the bezel retaining screws	6-33
Figure 6-20: Disconnecting the STBY/ON circuit board	6-34
Figure 6-21: Removing the retaining screws from the Keypad board	6-35
Figure 6-22: Orienting connector J933 for installation on the Keypad board	6-36
Figure 6-23: Removing the CRT assembly retaining screws	6-37
Figure 6-24: Removing the power supply retaining screws	6-39
Figure 6-25: Removing the Interconnect board assembly retaining screws	6-41
Figure 6-26: Removing the cooling fan	6-42
Figure 6-27: Construction of rack slides	6-45
Figure 6-28: Rail detail for mounting rack slides	6-46
Figure 6-29: Mounting stationary rack sections	6-47
Figure 6-30: Installing and removing the VM700T from the rack .	6-48
Figure 6-31: VM700T diagnostics menus overview	6-57
Figure 6-32: VM700T diagnostic menus overview (cont.)	6-58
Figure 6-33: VM700T startup menu	6-59
Figure 6-34: Low level diagnostics menu	6-60
Figure 6-35: Low level diagnostic OVERALL RUN MODE menu .	6-61
Figure 6-36: Custom run mode menu	6-62
Figure 6-37: Build CUSTOM TEST SEQUENCE menu for display	6-63
Figure 6-38: Front Panel diagnostic selection buttons	6-64
Figure 6-39: Special power-up boot modes	6-65
Figure 6-40: VM700T Startup menu	6-66
Figure 6-41: Diagnostic Utilities menu	6-66
Figure 6-42: Clear File System Utility menu	6-68
Figure 6-43: Clear CPU NVRAM Utility menu	6-68

Figure 6-44: Touch screen calibration (display)	6-69
Figure 6-45: Touch screen calibration (panel)	6-69
Figure 6-46: Panel calibration values	6-70
Figure 6-47: Diagnostic configuration menu	6-70
Figure 6-48: Set diagnostics power-up mode menu	6-71
Figure 6-49: Instrument run modes menu	6-72
Figure 6-50: Normal Boot switch setting	6-73
Figure 6-51: High level diagnostics menu	6-74
Figure 6-52: Select run mode, the high level diagnostic initial menu	6-75
Figure 6-53: Interactive run mode menu after running first main test	6-77
Figure 6-54: Power-up diagnostics selection display	6-78
Figure 6-55: High level diagnostics test blocks	6-79
Figure 6-56: Instrument Run Modes menu	6-85
Figure 6-57: Boot switch setting to enable diagnostic output to serial port 0	6-86
Figure 6-58: Diagnostics Configuration menu	6-86
Figure 6-59: VM700T rear panel	6-87
Figure 6-60: Front-panel power supply and over temperature indicators	6-90
Figure 6-61: Power supply LED indicators	6-91
Figure 6-62: Power supply test points	6-93
Figure 6-63: Procedure for troubleshooting the audio option boards	6-95
Figure 6-64: Test positions on the Audio Analog board	6-96
Figure 6-65: SDI board cable connections and J5 pinouts	6-102
Figure 6-66: Option 1S simplified block diagram	6-105
Figure 6-67: Signal connections for performing Option 1S diagnostic tests	6-105
Figure 9-1: VM700T Video Measurement Set simplified block diagram	9-3
Figure 9-2: VM700T Video Measurement Set interconnection diagram	9-4
Figure 10-1: Front assemblies and power supply	10-15
Figure 10-2: Circuit boards	10-17
Figure 10-3: Chassis assembly	10-19
Figure 10-4: Cabinet and accessories	10-21
Figure 10-5: Option 1S circuit boards	10-23
Figure 10-6: Circuit board fuse locations	10-25

List of Tables

Table 1-1: Input characteristics	1-1
Table 1-2: Digitizer	1-2
Table 1-3: Synchronization	1-3
Table 1-4: Physical characteristics	1-4
Table 1-5: Power requirements	1-4
Table 1-6: Environmental specification	1-4
Table 1-7: Certifications and compliances	1-6
Table 1-8: Safety standards	1-7
Table 1-9: Safety certification compliance	1-7
Table 1-10: Rear panel signal connectors	1-8
Table 1-11: Optional power cords	1-9
Table 1-12: AC Electrical Characteristics	1-10
Table 1-13: Power Line Conditioner Mechanical Characteristics	1-10
Table 1-14: Power Line Conditioner Environmental Characteristics	1-11
Table 1-15: Bar Line Time	1-12
Table 1-16: Bounce	1-12
Table 1-17: Burst Frequency	1-13
Table 1-18: Chrominance to Luminance	1-13
Table 1-19: Chrominance Noise	1-13
Table 1-20: Chrominance Nonlinearity	1-13
Table 1-21: Color Bar	1-13
Table 1-22: Differential Gain and Phase	1-14
Table 1-23: Frequency Response and Group Delay	1-14
Table 1-24: Horizontal Blanking	1-14
Table 1-25: Horizontal Timing	1-14
Table 1-26: Incidental Carrier Phase Modulation	1-15
Table 1-27: Jitter	1-15
Table 1-28: K-Factor	1-15
Table 1-29: Level Meter	1-15
Table 1-30: Line Frequency	1-15
Table 1-31: Luminance Nonlinearity	1-15
Table 1-32: MultiBurst	1-16
Table 1-33: Noise Spectrum	1-16
Table 1-34: SCH Phase	1-16
Table 1-35: Two Field	1-16
Table 1-36: Vertical Blanking	1-16
Table 1-37: VITS ID	1-17

Table 1-38: Line Blanking timing measurements	1-17
Table 1-39: Field Blanking timing measurements	1-17
Table 1-40: Other Timing measurements	1-18
Table 1-41: Amplitude and Phase measurements	1-18
Table 1-42: Frequency Response measurements	1-19
Table 1-43: Waveform Distortion measurements	1-19
Table 1-44: Low Frequency Error	1-20
Table 1-45: Noise measurements	1-20
Table 1-46: Incidental Carrier Phase Modulation	1-20
Table 1-47: Bar Line Time	1-21
Table 1-48: Bounce	1-21
Table 1-49: Burst Frequency	1-22
Table 1-50: Chrominance-to-Luminance Gain and Delay	1-22
Table 1-51: Chrominance Frequency Response	1-22
Table 1-52: Chrominance Noise	1-22
Table 1-53: Chrominance Non-Linearity	1-22
Table 1-54: ColorBar	1-22
Table 1-55: SMPTE color bar nominal values	1-23
Table 1-56: Differential Gain and Phase	1-23
Table 1-57: Frequency Response and Group Delay	1-23
Table 1-58: Horizontal Blanking	1-23
Table 1-59: Horizontal Timing	1-23
Table 1-60: Incidental Carrier Phase Modulation	1-24
Table 1-61: Jitter	1-24
Table 1-62: K-Factor	1-24
Table 1-63: Level Meter	1-24
Table 1-64: Line Frequency	1-24
Table 1-65: Luminance Non-Linearity	1-25
Table 1-66: Multiburst	1-25
Table 1-67: Noise Spectrum	1-25
Table 1-68: SCH Phase	1-25
Table 1-69: Short Time Distortion	1-25
Table 1-70: Two Field	1-25
Table 1-71: VITS ID	1-26
Table 1-72: Vertical Blanking	1-26
Table 1-73: RS-170A horizontal blanking interval timing	1-26
Table 1-74: RS-170A vertical blanking interval	1-27
Table 1-75: FCC horizontal blanking interval timing	1-27

Table 1-76: FCC vertical blanking interval timing	1-27
Table 1-77: Amplitude and Phase measurements	1-27
Table 1-78: Frequency Response measurements	1-28
Table 1-79: Incidental Carrier Phase Modulation	1-28
Table 1-80: Color Bar measurements	1-29
Table 1-81: Out-of-Service measurements	1-29
Table 1-82: Waveform Distortion measurements	1-29
Table 1-83: VIRS measurements	1-29
Table 1-84: Signal-to-Noise Ratio measurements	1-30
Table 1-85: O.33 Automatic audio test measurement specifications	1-31
Table 1-86: Tektronix automatic audio test measurement specifications	1-32
Table 1-87: Frequency and Noise specifications	1-32
Table 1-88: Accuracy and Flatness specifications	1-34
Table 1-89: General Audio Spectrum specifications	1-34
Table 1-90: Audio Spectrum Level measurement specifications ...	1-34
Table 1-91: Harmonic Analyzer measurement specifications	1-35
Table 1-92: Miscellaneous specifications	1-35
Table 1-93: Multitone Analyzer measurement specifications	1-35
Table 1-94: Audio/Video Timing measurement specifications	1-36
Table 1-95: IEEE 488.1 interface functions implemented in the VM700T GPIB interface card	1-37
Table 1-96: GPIB Electrical characteristics	1-37
Table 1-97: Mechanical specifications	1-38
Table 1-98: Optional accessories	1-38
Table 1-99: SDI Eye Diagram application	1-38
Table 1-100: SDI Jitter application	1-39
Table 1-101: SDI Wander application	1-40
Table 1-102: SDI Interchannel Timing application	1-40
Table 1-103: SDI Audio/Video Timing application	1-41
Table 1-104: SDI Ch. A Input	1-42
Table 1-105: SDI Ch. B Input	1-43
Table 1-106: LTC Input	1-43
Table 1-107: SDI Output	1-44
Table 1-108: Analog Ref. Input	1-44
Table 1-109: AES Audio Input	1-44
Table 1-110: Environmental specification	1-44

Table 2-1: Audio Option 41 connector pin assignments	2-20
Table 2-2: Status indicators	2-21
Table 3-1: Signals used by VM700T RS-232C ports	3-19
Table 4-1: Test equipment required for verification	4-6
Table 4-2: Test equipment required for verification procedures ...	4-14
Table 4-3: Accuracy and flatness specifications	4-15
Table 4-4: Example test signals for level and flatness test	4-16
Table 4-5: Accuracy and flatness specifications	4-20
Table 4-6: Example test signals for level and flatness test	4-21
Table 4-7: Test equipment required for Option 1S verification ...	4-25
Table 5-1: Test equipment required for verification and adjustment	5-1
Table 5-2: Gain-phase analyzer setup	5-16
Table 5-3: Gain-phase analyzer setup for ADC	5-19
Table 5-4: Test equipment required for Option 1S adjustment	5-22
Table 5-5: SDI Eye Diagram application gain and offset value limits	5-24
Table 5-6: Jitter application adjustment value limits	5-25
Table 5-7: Cable meter adjustment value limits	5-27
Table 6-1: Static susceptibility	6-2
Table 6-2: Audio Option 41 connector pin assignments	6-12
Table 6-3: VM700T symptoms and corrective actions	6-52
Table 6-4: User-selectable diagnostics	6-80
Table 6-5: Diagnostic test number to hardware components tested cross reference	6-83
Table 6-6: Typical communication setup parameters	6-87
Table 6-7: VM700T RS-232 connector pin outs	6-88
Table 6-8: Typical RS-232C null modem cable wiring	6-89
Table 6-9: Power supply trouble indicators	6-92
Table 6-10: Power supply voltages	6-93
Table 6-11: Audio Processor board diagnostics	6-97
Table 6-12: Audio Analog board diagnostics	6-98
Table 6-13: SDI Option 1S diagnostic test descriptions	6-107
Table 7-1: Optional accessories	7-5
Table 7-2: Power cord options	7-6

General Safety Summary

Review the following safety precautions to avoid injury and prevent damage to this product or any products connected to it. To avoid potential hazards, use this product only as specified.

Only qualified personnel should perform service procedures.

To avoid potential hazards, use this product only as specified.

To Avoid Fire or Personal Injury

Use Proper Power Cord. Use only the power cord specified for this product and certified for the country of use.

Use Proper Voltage Setting. Before applying power, ensure that the line selector is in the proper position for the power source being used.

Ground the Product. This product is grounded through the grounding conductor of the power cord. To avoid electric shock, the grounding conductor must be connected to earth ground. Before making connections to the input or output terminals of the product, ensure that the product is properly grounded.

Observe All Terminal Ratings. To avoid fire or shock hazard, observe all ratings and markings on the product. Consult the product manual for further ratings information before making connections to the product.

Do Not Operate Without Covers. Do not operate this product with covers or panels removed.

Use Proper Fuse. Use only the fuse type and rating specified for this product.

Avoid Exposed Circuitry. Do not touch exposed connections and components when power is present.

Do Not Operate With Suspected Failures. If you suspect there is damage to this product, have it inspected by qualified service personnel.

Do Not Operate in Wet/Damp Conditions.

Do Not Operate in an Explosive Atmosphere.

Keep Product Surfaces Clean and Dry.

Provide Proper Ventilation. Refer to the manual's installation instructions for details on installing the product so it has proper ventilation.

Symbols and Terms

Terms in this Manual. These terms may appear in this manual:



WARNING. *Warning statements identify conditions or practices that could result in injury or loss of life.*



CAUTION. *Caution statements identify conditions or practices that could result in damage to this product or other property.*

Terms on the Product. These terms may appear on the product:

DANGER indicates an injury hazard immediately accessible as you read the marking.

WARNING indicates an injury hazard not immediately accessible as you read the marking.

CAUTION indicates a hazard to property including the product.

Symbols on the Product. The following symbols may appear on the product:



WARNING
High Voltage



Protective Ground
(Earth) Terminal



CAUTION
Refer to Manual



Double
Insulated

Service Safety Summary

Only qualified personnel should perform service procedures. Read this *Service Safety Summary* and the *General Safety Summary* before performing any service procedures.

Do Not Service Alone. Do not perform internal service or adjustments of this product unless another person capable of rendering first aid and resuscitation is present.

Disconnect Power. To avoid electric shock, disconnect the main power by means of the power cord or, if provided, the power switch.

Use Caution When Servicing the CRT. To avoid electric shock or injury, use extreme caution when handling the CRT. Only qualified personnel familiar with CRT servicing procedures and precautions should remove or install the CRT.

CRTs retain hazardous voltages for long periods of time after power is turned off. Before attempting any servicing, discharge the CRT by shorting the anode to chassis ground. When discharging the CRT, connect the discharge path to ground and then the anode. Rough handling may cause the CRT to implode. Do not nick or scratch the glass or subject it to undue pressure when removing or installing it. When handling the CRT, wear safety goggles and heavy gloves for protection.

Use Care When Servicing With Power On. Dangerous voltages or currents may exist in this product. Disconnect power, remove battery (if applicable), and disconnect test leads before removing protective panels, soldering, or replacing components.

To avoid electric shock, do not touch exposed connections.

X-Radiation. To avoid x-radiation exposure, do not modify or otherwise alter the high-voltage circuitry or the CRT enclosure. X-ray emissions generated within this product have been sufficiently shielded.

Preface

This is a service manual for the VM700T Video Measurement Set. It is a module-level repair manual for use by a qualified service person in the isolation of faulty modules and repair by module exchange.

Contents of the Manual

This manual contains the following sections:

1. *Specification* lists the major specifications of the VM700T as an instrument. Option specifications are contained in the associated Option User Manuals.
2. *Operating Information* introduces the VM700T, gives the basic installation instructions, describes its major features, and the controls and connectors of the instruments.
3. *Theory of Operation* contains functional block descriptions of the VM700T circuit board modules to aid in understanding the instrument for servicing.
4. *Performance Verification* has the procedures for verifying the operation of the VM700T and the audio options.
5. *Adjustment Procedure* has the procedures for returning the VM700T to specification after a circuit board module exchange.
6. *Maintenance* provides the customer service information and illustrated, step-by-step procedures for removing and replacing the field-replaceable modules of the VM700T. Installation instructions for the rack mounted instrument are in this section. Troubleshooting and diagnostic information is provided to help you troubleshoot the VM700T to isolate a faulty circuit board module for a module exchange repair.
7. *Options* has a listing with a short description of the available options for the VM700T.
8. *Replaceable Electrical Parts List* refers you to the *Replaceable Mechanical Parts List* for the list of replaceable electrical parts.
9. *Diagrams* provides an overall block diagram and a circuit board interconnection diagram to assist in faulty module isolation procedures.
10. *Replaceable Mechanical Parts List* has exploded views and gives the lists of the replaceable mechanical parts to aid in locating a replacement mechanical part. The assembly Tektronix part numbers are also included in this list as a convenience.

Specification

The performance limits in this specification are valid with the following conditions:

- This instrument must have been calibrated/adjusted at an ambient temperature between +20° C and +30° C.
- The instrument must be in an environment with temperature, altitude, humidity, and vibration within the operating limits described in this specification.
- The instrument must have had a warm-up period of at least 20 minutes.
- The instrument must have had its signal-path-compensation routine last executed after at least a 20 minute warm-up period at an ambient temperature within $\pm 5^\circ$ C of the current ambient temperature.

Any conditions that are unique to a particular characteristic are expressly stated as part of that characteristic.

Electrical Characteristics

Table 1-1: Input characteristics

Characteristic	Performance requirement	Supplemental information
Channel A, B, and C		User selectable. Differential A – B, A - C, B - A, B – C, C – A, and C - B may also be digitized for parallel component testing.
Input Type	Loop-through BNC connectors	
Return Loss (75 Ω)	Greater than 46 dB from 0 to 5 MHz	Channels A, B, and C are loop-through terminated in 75 Ω in use or not; power on or off.
Input Signal Range	+3, –6 dB with respect to 1 V_{p-p} nominal video (1.41 V_{p-p} to 0.5 V_{p-p}) terminated in 75 Ω .	
Coupling		DC, AC, Clamp

Table 1-1: Input characteristics (cont.)

Characteristic	Performance requirement	Supplemental information
Clamp		Independently programmable on each channel as follows: 1. Timing with respect to sync 2. Clamp pulse width 3. Clamp reference level 4. Clamp time constant
Hum Rejection		
Fast	Greater than 24 dB	
Slow	Less than 1 dB	
External Sync		Provided through a rear panel input
Crosstalk Between Channels		Greater than 70 dB isolation between channels. Measured at F_{SC} between A, B, C, and EXT SYNC
Residual Noise Level (0 to 5 MHz)	Better than -80 dB with respect to 0.714 V_{p-p} active video	

Table 1-2: Digitizer

Characteristic	Performance requirement	Supplemental information
Distortions		
2nd Harmonic		-70 dB or less; with 2.5 MHz, -1 dBfs signal
Noise		-60 dBfs _{RMS} , typical; with 5 MHz, -50 dBfs input
Anti-aliasing filter attenuation		
At 7.16 MHz (NTSC)	35 dB or greater	
At 8.86 MHz (PAL)	40 dB or greater	

Table 1-3: Synchronization

Characteristic	Performance requirement	Supplemental information
Modes		Video input or external (Sound-in-syncs and PCM2 capable without jumper options.)
Amplitudes		
Internal		
Minimum	-14 dB with respect to 286 mV nominal sync amplitude	
Maximum	+12 dB with respect to 286 mV nominal sync amplitude	
External		
Minimum	-8 dB with respect to 286 mV nominal sync amplitude	Composite sync
Maximum	8 V peak-to-peak	Composite sync

Physical Characteristics

Table 1-4: Physical characteristics

Characteristic	Description
Dimensions (W × H × D)	19.0 in × 8.75 in × 21.9 in (483 mm × 222 mm × 556 mm)
Weight	45 lb (20 kg)
Shipping Weight	Approximately 71 lb (33 kg)

Power Requirements

Table 1-5: Power requirements

Characteristic	Description
Mains Voltage	90 VAC to 132 VAC (115 VAC nominal)
	180 to 250 VAC (230 VAC nominal)
Mains Frequency	50 or 60 Hz
Power Consumption	250 Watts (400 VA maximum)
Fuse Rating	
Low Input Range	6A slow blow
High Input Range	3A slow blow
Cooling Method	Forced-air circulation

Environmental

Table 1-6: Environmental specification

Characteristic	Performance requirement
Temperature	
Operating	0° C to +50° C
Nonoperating	-55° C to +75° C
Altitude	
Nonoperating	To 50,000 feet (15240 meters)
Operating	To 15,000 feet (4572 meters)
Sine Vibration	

Table 1-6: Environmental specification (Cont.)

Characteristic	Performance requirement
Operating	10 Hz - 55 Hz, 0.015 inch peak-to-peak, 15 minutes total cycling time per axis for three axes followed by a 10 minute dwell at the identified resonance frequency or at 33 Hz if none is found.
Shock Nonoperating	50 g's, 1/2 sine, 11 ms duration, 3 shocks per surface (18 shocks)
Transportation	Qualified under NTSB Test Procedure 1A, Category II (30 inch drop)
Humidity Operating	Up to 95% at or below 50° C
Nonoperating	Up to 95% at or below 60° C

Table 1-7: Certifications and compliances

Category	Description
EC Declaration of Conformity	<p>Meets intent of Directive 89/336/EEC for Electromagnetic Compatibility and Low Voltage Directive 73/23/ECC for Product Safety. Compliance was demonstrated to the following specifications as listed in the Official Journal of the European Communities:</p> <p>EN 55103 Product family standard for audio, video, audio-visual and entertainment lighting control apparatus for professional use¹</p> <p>Environment E2 - commercial and light industrial</p> <p>Part 1 Emissions:</p> <p>EN 55022 Class B Radiated and Conducted Emissions</p> <p>EN 55103-1, Annex A Radiated magnetic field emissions</p> <p>EN 55103-1, Annex B Inrush Current²</p> <p>EN 61000-3-2 AC Power Line Harmonic Emissions³</p> <p>Part 2 Immunity:</p> <p>IEC 61000-4-2 Electrostatic Discharge Immunity</p> <p>IEC 61000-4-3 RF Electromagnetic Field Immunity</p> <p>IEC 61000-4-4 Electrical Fast Transient/Burst Immunity</p> <p>IEC 61000-4-5 Power Line Surge Immunity</p> <p>IEC 61000-4-6 Conducted RF Immunity</p> <p>IEC 61000-4-11 Voltage Dips and Interruptions Immunity</p> <p>EN 55103-2, Annex A Radiated Magnetic Field Immunity</p> <p>EN 55103-2, Annex B Balanced Ports Common Mode Immunity</p>
Australia/New Zealand Declaration of Conformity - EMC	<p>Complies with EMC provision of Radiocommunications Act per the following standard(s):</p> <p>AN/NZS 2064.1/2 Industrial, Scientific, and Medical Equipment: 1992</p>
FCC Compliance	The instrument complies with the radiated and conducted emissions requirements of FCC Code of Federal Regulation 47, Part 15, Subpart B, Class A limits.

¹ **To ensure compliance with the above requirements, only high-quality shielded interface cable should be attached to this instrument. High-quality cables have a reliable, continuous outer shield (braid and foil) that has low impedance connections to shielded connector housings at both ends.**

² **Peak Inrush Current: 35.5 A @ 230 VAC, 50 Hz.**

³ **VM700T with Power Line Conditioner accessory used on 230 Vac power mains.**

Table 1-8: Safety standards

Category	Description
U.S. Nationally Recognized Testing Laboratory Listing	UL3111-1 - Standard for Electrical and Electronic Measuring and Testing Equipment
Canadian Certification	CAN/CSA C22.2 No. 1010.1 - Safety Requirements for Electrical Equipment for Measurement, Control and Laboratory Use
European Declaration of Conformity	Compliance was demonstrated to the following specification as listed in the Official Journal of European Communities: Low Voltage Directive 73/23/EEC; amended by 93/68/EEC: EN61010-1/A2 1995 - Safety Requirements for Electrical Equipment for Measurement, Control, and Laboratory Use
Additional Compliance	ANSI/ISA S82.02.01 - Safety Standard for Electrical and Electronic Test, Measuring, Controlling, and Related Equipment, 1994 IEC1010-1 - Safety Requirements for Electrical Equipment for Measurement, Control, and Laboratory Use

Table 1-9: Safety certification compliance

Category	Description
Temperature (operating)	+5° C to +50° C
Altitude (maximum operating)	2000 Meters
Relative Humidity (maximum operating)	80% for temperatures up to 31° C, decreasing linearly to 50% to at 40° C
Equipment Type	Test and Measuring
Safety Class	Class I (as defined in IEC 1010-1, Annex H) - grounded product
Overvoltage Category	Mains - Overvoltage Category II (as defined in IEC 1010-1, Annex J). Local-level mains, appliances, portable equipment
Pollution Degree	Pollution Degree 2 (as defined in IEC 1010-1). Do not operate in environments where conductive pollutants may be present. Note - Rated for indoor use only

Table 1-10: Rear panel signal connectors

Characteristic	Description
Port 0 and Port 1 Connectors	DB-9, male connectors, configured as RS-232C DTE ports to provide hardcopy output to serial printers and remote control
GPIB Connector (Option 48)	Meets electrical specifications described in IEEE-488 for parallel GPIB connectors
VGA Connector	15 pin, D-type. Outputs VGA signals
Parallel Printer Connector	DB-25 female; Centronics-compatible connector and signals
Remote Contact Closure Relay (Alarm)	Contacts are not debounced
Maximum Current	50 mA
Maximum Voltage	30 VAC _{RMS} or 30 VDC
Control Logic	set GRLY 1 closes the relay set GRLY 0 opens the relay
CH A, CH B, CHC, and Ext Sync Feed-Through Connectors	BNC. 75 Ω Termination required when not used as feed-through signal path.

Table 1-11: Optional power cords

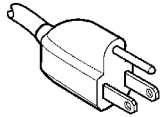
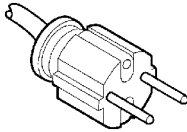
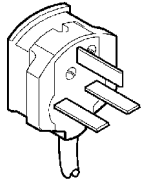
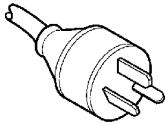
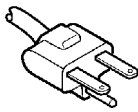
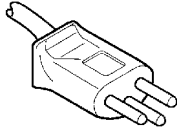
Plug configuration	Normal usage	Option number
	North America 125 V/15A Plug NEMA 5-15P	Standard
	Europe 230 V	A1 ¹
	United Kingdom 230 V	A2 ¹
	Australia 230 V	A3
	North America 230 V	A4
	Switzerland 230 V	A5

¹ European and United Kingdom power cord options A1 and A2 also require the VM700T power line conditioning box for operation in EU countries. The power line conditioner prevents power spikes from the VM700T power supply from entering the commercial power mains.

Power Line Conditioner for Option A1 and A2 Power Cords

Table 1-12: AC Electrical Characteristics

Characteristic	Description
Voltage Range	230 VAC, $\pm 10\%$ (207 to 253 VAC), 50/60 Hz, single phase ¹ , CAT II
Maximum Power Consumption	400 VA maximum (250 Watts) with VM700T load
Fuse Rating	3 Amp, 250 V, Time Delay
Fuse Style	3 AG
Steady State Input Current	1.5 Arms @ 207 VAC, 1.2 Arms @260 VAC
Inrush Surge Current	Protected with a 3A, Time Delay fuse
Power Cord ²	161-0066-09 Euro 161-0066-10 U.K.

¹ See the VM700T Power Requirements in Table 1-5 for the operating voltage range of the VM700T without the Power Line Conditioner box inline.

² Use the part numbers listed above to order a new power cord for use with the VM700T Power Line Conditioner box.

Table 1-13: Power Line Conditioner Mechanical Characteristics

Characteristic	Description
Size	
Length	7 inches (177.8 mm)
Width	4.55 inches (115.6 mm)
Height	2.67 inches (67.8 mm) (without the feet attached)
Weight	2 lbs, 13.5 oz. (1.29 kg)
Shipping weight	Approximately 3 lbs (1.36 kg)

Table 1-14: Power Line Conditioner Environmental Characteristics

Characteristic	Description
Temperature	
Operating	5° C to 50° C (41° F to 122° F) ¹ , 30° C (54° F)/hr max gradient, non-condensing (derated 1° C or 1.8° F per 1,000 ft. or 305 m above 5,000 ft. or 1524 m altitude)
Non-operating	-20° C to 60° C (-4° F to 140° F), 30° C (54° F)/hr max gradient
Humidity	
Operating	20% to 80% relative humidity, non-condensing. Max wet bulb temperature: 29.4° C or 84.9° F (derates relative humidity to ~46% at 40° C or 104° F)
Non-operating	8% to 80% relative humidity, non-condensing. Max wet bulb temperature: 40° C or 104° F (derates relative humidity to ~54% at 50° C or 122° F)
Altitude	
Operating	2000 meters maximum
Non-operating	Up to 40,000 ft (12,190 m)
Shake	<p>Tektronix Class 5 Random Vibration Non-operating Test: For Laboratory/Benchtop Instruments</p> <p>10 minutes of vibration in each of the 3 major axes including the following levels: 0.0175 g²/Hz from 5 to 100 Hz, -3 dB/octave from 100 to 200 Hz., 0.00875 g²/Hz from 200 to 350 Hz, -3 dB/octave from 350 to 500 Hz, 0.006132 at 500 Hz. Overall level of 2.28 GRMS</p> <p>Tektronix Class 5 Random Vibration Operating Test: For Laboratory/Benchtop Instruments (instrument meets performance specifications at these levels):</p> <p>10 minutes of vibration in each of the 3 major axes including the following levels: 0.00015 g²/Hz from 5 to 350 Hz, -3 dB/octave from 350 to 500 Hz., 0.000105 g²/Hz at 500 Hz. Overall level of 0.27 GRMS.</p>
Shock	<p>Tektronix Class 5 Shock Test</p> <p>16 drops, 4 axes, 30 Grms @ 11mS half-sine wave</p>

- 1 See the VM700T Environmental Characteristics in Table 1-6 for the operating temperature range of the VM700T operating without the Power Line Conditioner box inline.**

PAL Measurement Specifications

This section lists the specifications for each PAL measurement. The accuracies shown for measurements with averaging capabilities assume the default averaging factor of 32. Test signals of known parameters are provided by characterized and traceable television signal generators to test the accuracy of these derived measurements. Due to the statistical nature of digitizing measurement methods, reported results will meet these specifications 97% of the time.

All measurement accuracies specified are valid only with nominal inputs signals with an unweighted signal-to-noise ratio of at least 60 dB on the incoming signal and a termination accuracy of $\pm 0.025\%$. Accuracies shown for measurements with “relative mode accuracy” assume that an averaging factor of 256 was used to create the reference. Range specifies the extremes between which a measurement can be made.

Measure Mode

Table 1-15: Bar Line Time

Measurement	Range	Absolute mode accuracy	Relative mode accuracy
Bar Level (b1 or Back Porch)	300 mV to 1.4 V	$\pm 0.5\%$	$\pm 0.2\%$
Sync Level	50 mV to 600 mV	$\pm 0.5\%$	$\pm 0.2\%$
Sync to Bar Top	350 mV to 2 V	$\pm 0.5\%$	$\pm 0.2\%$
Sync/Bar Ratio	10% to 125% (100% nominal)	$\pm 0.5\%$	$\pm 0.2\%$
Bar Tilt (Rec 569)	0 to 20%	$\pm 0.2\%$	$\pm 0.1\%$
Line Time Distortion (Rec 567)	0 to 20%	$\pm 0.2\%$	$\pm 0.1\%$
Bar Width	10 μ s to 30 μ s	± 100 ns	NA

Table 1-16: Bounce

Measurement	Range	Accuracy
Peak Deviation	0 to 50%	$\pm 1\%$
Settling Time	0 to 10 sec	± 100 msec

Table 1-17: Burst Frequency

Measurement	Range	Relative mode accuracy
Burst Frequency	±100 Hz	±0.5 Hz

Table 1-18: Chrominance to Luminance

Measurement	Range	Absolute mode accuracy	Relative mode accuracy
Chrominance to Luminance Delay	±300 ns	±5 ns	±1.0 ns
Chrominance to Luminance Gain Ratio	0 to 160%	±1.0%	±0.1%

Table 1-19: Chrominance Noise

Measurement	Range	Absolute mode accuracy
AM Noise	20 dB to 80 dB	1 dB (20 dB to 60 dB)
PM Noise	20 dB to 70 dB	1 dB (20 dB to 60 dB)

Table 1-20: Chrominance Nonlinearity

Measurement	Range	Absolute mode accuracy	Relative mode accuracy
Chrominance Amplitude	0 to 100%	±1.0%	±0.5%
Chrominance Phase	0 to 360°	±1°	±0.2°
Chrominance to Luminance Intermodulation	-50% to +50%	±0.2%	±0.2%

Table 1-21: Color Bar

Measurement	Range	Absolute mode accuracy	Relative mode accuracy
Luminance Level	0 to 700 mV	±3.5 mV	±0.2%
Chrominance Level (excluding gray and black)	0 to 700 mV	±1.0% of nominal	±0.2%
Chrominance Phase	±180°	±0.5°	±0.1°

Table 1-22: Differential Gain and Phase

Measurement	Range	Absolute mode accuracy	Relative mode accuracy
Differential Gain (Minimum, Maximum, and Peak)	0 to 100%	±0.3%	±0.03%
Differential Phase (Minimum, Maximum, and Peak)	0 to 360°	±0.3°	±0.03°

Table 1-23: Frequency Response and Group Delay

Measurement	Range	Absolute mode accuracy	Relative mode accuracy
Frequency Response to 5 MHz	±40 dB	±1.0 dB	±0.3 dB
to 6 MHz	±40 dB	±2.0 dB	±0.6 dB
Group Delay to 5 MHz	±1.0 µs	±20 ns	±5 ns
to 6 MHz	±1.0 µs	±40 ns	±10 ns

Table 1-24: Horizontal Blanking

Measurement	Range	Absolute mode accuracy
Blanking Start	0.1 µs to 4.2 µs	±50 ns
Blanking End	6.8 µs to 12.2 µs	±50 ns
Blanking Width	6.9 µs to 16.4 µs	±50 ns

Table 1-25: Horizontal Timing

Measurement	Range	Absolute mode accuracy
Burst Level	80 mV to 600 mV	±1%
Horizontal Sync Rise and Fall Time	80 ns to 1 µs	±10 ns
Horizontal Sync Width	1 µs to 8 µs	±10 ns
Burst Width	1.4 µs to 3 µs	±25 ns
Sync to Burst Start	5 µs to 8 µs	±25 ns
Sync Level	75 mV to 600 mV	±0.5%

Table 1-26: Incidental Carrier Phase Modulation

Measurement	Range	Accuracy
ICPM (requires zero Carrier Pulse and the quadrature output of the demodulator on Channel C)	0 to 90°	±1.0°

Table 1-27: Jitter

Measurement	Range	Absolute mode accuracy
Jitter (2 Field)	±20 μs	±10 ns
Jitter Long Time	±20 μs	±10 ns

Table 1-28: K-Factor

Measurement	Range	Absolute mode accuracy
2T Pulse K-Factor	0 to 10% Kf	±0.3%
K _{PB}	-10% to +5% K _{PB}	±0.3%
Pulse to Bar Ratio	10% to 125%	±0.7%
Pulse Half Amplitude Duration (HAD)	100 ns to 500 ns	±5 ns

Table 1-29: Level Meter

Measurement	Range	Accuracy
Level Meter	0 to 1.4 V	±3.5 mV

Table 1-30: Line Frequency

Measurement	Range	Accuracy
Line Frequency	±3%	±0.1%
Field Frequency	±3%	±0.1%

Table 1-31: Luminance Nonlinearity

Measurement	Range	Absolute mode accuracy	Relative mode accuracy
Luminance NonLinearity	0 to 100%	±0.4%	±0.2%

Table 1-32: MultiBurst

Measurement	Range	Absolute mode accuracy	Relative mode accuracy
MultiBurst Flag Amplitude	0 to 700 mV	±0.5%	NA
Packets 1-5 (0.5, 1.0, 2.0, 4.0, 4.8 MHz)	-40 dB to +6 dB	±0.1 dB	±0.03 dB
Packet 6 (5.8 MHz)	-40 dB to +6 dB	±0.2 dB	±0.06 dB

Table 1-33: Noise Spectrum

Measurement	Range	Absolute mode accuracy
Unweighted Signal-to-Noise (5 MHz Low Pass)	-20 dB to -80 dB	±0.4 dB (-20 dB to -60 dB) ±1.0 dB (-60 dB to -70 dB)
Luminance Weighted Signal-to-Noise (5 MHz Low Pass and Unified Weighting)	-20 dB to -80 dB	±1.0 dB (-20 dB to -60 dB) ±2.0 dB (-60 dB to -70 dB)
Chrominance Weighted Signal-to-Noise	-20 dB to -80 dB	±1.0 dB (-20 dB to -60 dB) ±2.0 dB (-60 dB to -70 dB)

Table 1-34: SCH Phase

Measurement	Range	Absolute mode accuracy
SCH Phase	±90°	±5°
Sync Relative Timing	±1 µs	±10 ns
Burst Relative Phase	±180°	±5°

Table 1-35: Two Field

Measurement	Range	Absolute mode accuracy
Field Time Distortion	0 to 35%	±0.5%

Table 1-36: Vertical Blanking

Measurement	Range	Absolute mode accuracy
Equalizing Pulse Width	80 ns to 1 µs	±10 ns
Broad Pulse Width	80 ns to 1 µs	±10 ns
Vertical Blanking Field 1	19 lines to 30 lines	NA
Vertical Blanking Field 2	19 lines to 30 lines	NA

Table 1-37: VITS ID

Measurement	Performance Requirement	Supplemental information
VITS Recognition		Recognizes and displays the name of recognized signals in the vertical interval of both Field 1 and Field 2, lines 15 through 20. VITS test signals recognized are: GCR 8 Fields Seq. VIRS FCC Multi Burst Pedestal Luminance Bar NTC-7 Combination Sin X/X

Auto Mode

Table 1-38: Line Blanking timing measurements

Measurement	Range	Accuracy
Colour Burst Duration	6 cycles to 13 cycles (10 cycles nominal)	±0.1 cycle
Front Porch Duration	0.5 µs to 3 µs (1.5 µs nominal)	±20 ns
Line Blanking	9 µs to 16 µs (12 µs nominal)	±50 ns
Line Sync Rise Time Fall Time	120 ns to 300 ns 300 ns to 1 µs	±15 ns ±30 ns
Line Sync	1.4 µs to 6.6 µs (4.7 µs nominal)	±10 ns
Sync-to-Start of Burst	2.2 µs to 8 µs (5.6 µs nominal)	±20 ns
Burst Duration	1.4 µs to 3 µs	±25 ns
SCH Phase	±90°	±5°

Table 1-39: Field Blanking timing measurements

Measurement	Range	Accuracy
Equalizing Pulse Duration	1.4 µs to 20 µs (2.35 µs nominal)	±10 ns
Broad Pulse Separation	1.4 µs to 20 µs (4.7 µs nominal)	±10 ns

Table 1-40: Other Timing measurements

Measurement	Range	Accuracy	ITS Element	Standard
Bar Rise Time	120 ns to 300 ns 0.3 μ s to 1.0 μ s	\pm 20 ns \pm 30 ns	B2	Measured from 10% to 90% points

Table 1-41: Amplitude and Phase measurements

Measurement	Range	Accuracy	ITS Element	Standard
Average Picture Level	0 to 200%	\pm 3%		
Sync Amplitude Error	+100% to -50% (300 mV nominal)	\pm 0.3% of nominal	Live picture area	CCIR Rec. 569
Sync Amplitude Error (with Sound-in-Sync)	+100% to -50% (300 mV nominal)	\pm 0.3% of nominal	Last broad pulse in field	CCIR Rec. 569
Burst Amplitude Error	+80% to -50% (300 mV nominal)	\pm 1.0%	Live picture area	CCIR Rec. 569
Chrominance Reference Amplitude Error	-80% to +50% (300 mV nominal)	\pm 1.0%	D2	CCIR Rec. 569
Luminance Bar Amplitude Error	+30% to -70% (700 mV nominal)	\pm 0.3%	B2	CCIR Rec. 569
Luminance Bar Amplitude	200 mV to 900 mV	\pm 2.2 mV	B2	
Luminance Bar Amplitude (% of carrier)	0 to 90% of Maximum Carrier	\pm 0.3%	B2 and Zero Carrier	
Residual Carrier (Bar Top)	0 to 90% of Maximum Carrier	\pm 0.3%	B2 and Zero Carrier	
Blanking Level	0 to 90% of Zero Carrier	\pm 0.2%	Live picture area	CCIR Rep. 624-1
Chrominance- Luminance Gain Inequality	\pm 75% of bar amplitude	\pm 1.0%	G1 or G2	CCIR Rec. 569
Chrominance- Luminance Delay Inequality	\pm 300 ns (0 ns nominal)	\pm 5 ns	F or G1 or G2	CCIR Rec. 569
Sync/Bar Rel. 3/7	20% to 110%	\pm 0.5%	B2	CCIR Rec. 569
Sync to Bar Top	0.5 V to 2 V	\pm 0.5%	B2	CCIR Rec. 569
C/L Gn Err (using modulated Pulse)	\pm 50%	\pm 1%	F	
Sync Amplitude	75 mV to 600 mV	\pm 2.1 mV		
Burst Amplitude	75 mV to 600 mV	\pm 3 mV		
Burst Amplitude Difference		\pm 2%		

Table 1-41: Amplitude and Phase measurements (cont.)

Measurement	Range	Accuracy	ITS Element	Standard
Burst Quadrature Error		$\pm 1^\circ$		
Differential Gain (Peak and p-p)	0 to +100% (0% nominal)	$\pm 0.3\%$	D2	CCIR Rec. 569
Differential Phase (Peak and p-p)	0 to 360° (0° nominal)	$\pm 0.3^\circ$	D2	CCIR Rec. 569

Table 1-42: Frequency Response measurements

Measurement	Range	Accuracy	ITS Element	Standard
MultiBurst Flag Amplitude	20% to 130% of bar (60% nominal)	$\pm 0.5\%$	C1	CCIR Rec. 567
MultiBurst Amplitude	0 to 200% of flag (100% nominal)	$\pm 1.5\%$ of flag ($\pm 2.5\%$ of 5.8 MHz packet)	C2	CCIR Rec. 567

Table 1-43: Waveform Distortion measurements

Measurement	Range	Accuracy	ITS Element	Standard
Baseline Distortion	50% of bar	$\pm 0.3\%$	B1	CCIR Rec. 569
2T Pulse/Bar Ratio Error	+25% to -90% (0% nominal)	$\pm 0.5\%$	B1	CCIR Rec. 569
2T Pulse K-factor	0 to 10% Kf (0% Kf nominal)	$\pm 0.3\%$ Kf	B1	CCIR Rec. 569
Bar Tilt (End Points)	0 to +40% (0% nominal)	$\pm 0.2\%$	B2	CCIR Rec. 567
Bar Tilt (Peak-to-Peak)	0 to +40% (0% nominal)	$\pm 0.2\%$	B2	CCIR Rec. 567
Line Time Distortion	0 to 40% of bar	$\pm 0.2\%$	B2	CCIR Rec. 560
Bar Tilt (Rec 569)	0 to 40% of bar	$\pm 0.2\%$	B2	CCIR Rec. 569
Field Time Distortion	0 to 35%	$\pm 0.5\%$	Field Square Wave	
Chrominance-Luminance Intermodulation	$\pm 50\%$ (0% nominal)	$\pm 0.2\%$	G1 or G2	CCIR Rec. 569
Luminance Non-linear Distortion	0 to 50% (0% nominal)	$\pm 0.4\%$	D1	CCIR Rec. 569

Table 1-44: Low Frequency Error

Measurement	Range	Accuracy	Standard
Low Frequency Error (reported as: CCIR LF Error 50-550 Hz LF Error 10-1000 Hz LF Error)	0% to 25% (0% nominal)	±0.8%	CCIR Rec. 569

Table 1-45: Noise measurements

Measurement	Range	Accuracy	Standard
Unweighted SNR (567)	26 dB to 60 dB 61 dB to 70 dB	±1.0 dB ±2.0 dB	Measured on one quiet line per CCIR Rec. 567
Luminance Weighted SNR (567)	26 dB to 60 dB 61 dB to 70 dB	±1.0 dB ±2.0 dB	Measured on one quiet line per CCIR Rec. 567
Chrominance Weighted SNR	26 dB to 60 dB 61 dB to 70 dB	±1.0 dB ±2.0 dB	Measured on one quiet line per CCIR Rep. 637-2
Periodic SNR	26 dB to 60 dB 61 dB to 70 dB	±1.0 dB ±2.0 dB	Measured on one quiet line per CCIR Rep. 637-2
Unweighted SNR (569)	26 dB to 60 dB 61 dB to 70 dB	±1.0 dB ±2.0 dB	Measured on one quiet line per CCIR Rec. 569
Luminance Weighted SNR (569)	26 dB to 60 dB 61 dB to 70 dB	±1.0 dB ±2.0 dB	Measured on one quiet line per CCIR Rec. 569

Table 1-46: Incidental Carrier Phase Modulation

Measurement	Range	Accuracy
ICPM (requires Zero-Carrier Pulse and the quadrature output of the demodulator on Channel C)	0 to 30°	±1.0°

NTSC Measurement Specifications

This section lists the specifications for each NTSC measurement. The accuracies shown for measurements with averaging capabilities assume the default averaging factor of 32. Test signals of known parameters are provided by characterized and traceable television signal generators to test the accuracy of these derived measurements. Due to the statistical nature of digitizing measurement methods, reported results will meet these specifications 97% of the time. Range specifies the extremes between which a measurement can be made.

All measurement accuracies specified are valid only with nominal inputs signals with an unweighted signal-to-noise ratio of at least 60 dB on the incoming signal and a termination accuracy of $\pm 0.025\%$. Accuracies shown for measurements with “relative mode accuracy” assume that an averaging factor of 256 was used to create the reference. An IRE is a voltage unit of measure and is equal to 1/140 of a volt or 7.14285 mv. 100 IRE is 714.285 mV. This value often rounded to 714 mV or, with less rounding, to 714.3 mV. A 1 V pk-pk signal is 140 IRE.

Measure Mode

Table 1-47: Bar Line Time

Measurement	Range	Absolute mode accuracy	Relative mode accuracy
Bar Level	50 IRE to 200 IRE	$\pm 0.5\%$	$\pm 0.2\%$
Sync Level	20 IRE to 80 IRE	$\pm 0.5\%$	$\pm 0.2\%$
Sync to Bar Top	70 IRE to 280 IRE	$\pm 0.5\%$	$\pm 0.2\%$
Sync/Bar Ratio	10% to 125% (100% nominal)	$\pm 0.5\%$	$\pm 0.2\%$
Bar Tilt (Rec 569)	0 to 20%	$\pm 0.2\%$	$\pm 0.1\%$
Line Time Distortion (Rec 567)	0 to 20%	$\pm 0.2\%$	$\pm 0.1\%$
Bar Width	10 μ s to 30 μ s	± 100 ns	NA

Table 1-48: Bounce

Measurement	Range	Accuracy
Peak Deviation	0 to 50%	$\pm 1\%$
Settling Time	0 to 10 sec	± 100 msec

Table 1-49: Burst Frequency

Measurement	Range	Relative mode accuracy
Burst Frequency Error	± 100 Hz	± 0.5 Hz

Table 1-50: Chrominance-to-Luminance Gain and Delay

Measurement	Range	Absolute mode accuracy	Relative mode accuracy
Chrominance to Luminance Delay	±300 ns	±5 ns	±1.0 ns
Chrominance to Luminance Gain Ratio	0 to 160%	±1.0%	±0.1%

Table 1-51: Chrominance Frequency Response

Measurement	Range	Absolute mode accuracy	Relative mode accuracy
Reference Amplitude	0 to 100 IRE	±1%	±0.5%
Frequency Response	0 to 100 IRE	±1%	±0.5%

Table 1-52: Chrominance Noise

Measurement	Range	Absolute mode accuracy
AM Noise	-20 dB to -80 dB	±1 dB (-20 dB to -60 dB)
PM Noise	-20 dB to -70 dB	±1 dB (-20 dB to -60 dB)

Table 1-53: Chrominance Non-Linearity

Measurement	Range	Absolute mode accuracy	Relative mode accuracy
Chrominance Amplitude	0 to 100%	1.0%	0.5%
Chrominance Phase	0 to 360°	1°	0.2°
Chrominance to Luminance Intermodulation	-50% to +50%	0.2%	0.2%

Table 1-54: ColorBar

Measurement	Range	Absolute mode accuracy	Relative mode accuracy
Luminance Level	0 to 100 IRE (0 to 714.3 mV)	±0.5 IRE	±0.2%
Chrominance Level (excluding gray and black)	0 to 100 IRE (0 to 714.3 mV)	±1.0% of nominal (see Table 1-55)	±0.2%
Chrominance Phase	±180° of nominal	±0.5° of nominal	±0.1°

Table 1-55: SMPTE color bar nominal values

Color	LUM (mV)	Chroma P-P (mV)	Phase (degrees)
Yellow	494.6	444.2	167.1
Cyan	400.4	630.1	283.4

Table 1-55: SMPTE color bar nominal values (Cont.)

Color	LUM (mV)	Chroma P-P (mV)	Phase (degrees)
Green	345.9	588.5	240.8
Magenta	256.7	588.5	60.8
Red	202.2	630.1	103.4
Blue	108.1	444.2	347.1

Table 1-56: Differential Gain and Phase

Measurement	Range	Absolute mode accuracy	Relative mode accuracy
Differential Gain	0 to 100%	±0.3%	±0.03%
Differential Phase	0 to 360°	±0.3°	±0.03°

Table 1-57: Frequency Response and Group Delay

Measurement	Range	Absolute mode accuracy	Relative mode accuracy
Frequency Response	±40 dB	±1.0 dB	±0.3 dB
Group Delay	±1.0 μs	±20 ns	±5 ns

Table 1-58: Horizontal Blanking

Measurement	Range	Absolute mode accuracy
Blanking Start	0.1 μs to 4.2 μs	±50 ns
Blanking End	6.8 μs to 12.2 μs	±50 ns
Blanking Width	6.9 μs to 16.4 μs	±50 ns

Table 1-59: Horizontal Timing

Measurement	Range	Absolute mode accuracy
Burst Level	10 to 80 IRE	±0.5%
Horizontal Sync Rise and Fall Time	80 ns to 1 μs	±10 ns
Horizontal Sync Width	3 μs to 7 μs	±10 ns
Burst Width	6 cycles to 13 cycles	±0.1 cycle (FCC) ±0.5 cycle (RS-170A)
Sync to Burst Start (RS-170A)	4 μs to 10 μs	±150 ns
Sync to Burst End (FCC)	4 μs to 10 μs	±25 ns
Front Porch	0.1 μs to 3.5 μs	±10 ns (FCC) ±10 ns (RS-170A)

Table 1-59: Horizontal Timing (cont.)

Measurement	Range	Absolute mode accuracy
Sync to Setup	8.8 μ s to 13.0 μ s	\pm 10 ns
Breezeway (FCC)	0.1 μ s to 5 μ s	\pm 25 ns
Sync Level	20 IRE to 80 IRE	\pm 0.5%

Table 1-60: Incidental Carrier Phase Modulation

Measurement	Range	Absolute mode accuracy
ICPM (requires zero Carrier Pulse and the quadrature output of the demodulator on Channel C)	0 to 90°	\pm 1.0°

Table 1-61: Jitter

Measurement	Range	Absolute mode accuracy
Jitter (2 Field)	\pm 20 μ s	\pm 10 ns
Jitter Long Time	\pm 20 μ s	\pm 10 ns

Table 1-62: K-Factor

Measurement	Range	Absolute mode accuracy
2T Pulse K-Factor	0 to 10% Kf	\pm 0.3%
K _{PB}	-10% to +5% K _{PB}	\pm 0.3%
Pulse to Bar Ratio	10% to 125%	\pm 0.7%
Pulse Half Amplitude Duration (HAD)	100 ns to 500 ns	\pm 5 ns

Table 1-63: Level Meter

Measurement	Range	Absolute mode accuracy
Level Meter	0 to 1.4 V	\pm 3.5 mV

Table 1-64: Line Frequency

Measurement	Range	Absolute mode accuracy
Line Frequency	\pm 3%	\pm 0.1%
Field Frequency	\pm 3%	\pm 0.1%

Table 1-65: Luminance Non-Linearity

Measurement	Range	Absolute mode accuracy	Relative mode accuracy
Luminance Non-Linearity	0 to 100%	±0.4%	±0.2%

Table 1-66: Multiburst

Measurement	Range	Absolute mode accuracy	Relative mode accuracy
Reference Flag or Packet Amplitude	30 IRE to 130 IRE	±1%	NA
Other Packets (0.5, 1.25, 2.0, 3.0, 3.58, 4.1 MHz)	-40 dB to +6 dB	±0.1 dB	±0.03 dB

Table 1-67: Noise Spectrum

Measurement	Range	Absolute mode accuracy
Unweighted Signal-to-Noise Ratio (5 MHz Low Pass)	-20 dB to -80 dB	±0.4 dB (-20 dB to -60 dB) ±1.0 dB (-60 dB to -70 dB)
Weighted Signal-to-Noise Ratio (5 MHz Low Pass and Unified Weighting)	-20 dB to -80 dB	±1.0 dB (-20 dB to -60 dB) ±2.0 dB (-60 dB to -70 dB)

Table 1-68: SCH Phase

Measurement	Range	Absolute mode accuracy
SCH Phase	±90°	±5°
Sync Relative Timing	±1 μs	±10 ns
Burst Relative Phase	180°	±5°

Table 1-69: Short Time Distortion

Measurement	Range	Absolute mode accuracy
Short-Time Distortion	0 to 25% SD	±5% SD

Table 1-70: Two Field

Measurement	Range	Absolute mode accuracy
Field Time Distortion	0 to 40%	±0.5%

Table 1-71: VITS ID

Measurement	Performance requirement	Supplemental information
VITS Recognition		Recognizes and displays the name of recognized signals in the vertical interval of both Field 1 and Field 2, lines 15 through 20. VITS test signals recognized are: GCR 8 Fields Seq. VIRS FCC Multi Burst Pedestal Luminance Bar NTC-7 Combination Sin X/X

Table 1-72: Vertical Blanking

Measurement	Range	Absolute mode accuracy
Equalizing Pulse Width	80 ns to 1 μ s	\pm 10 ns
Serration Pulse Width	80 ns to 1 μ s	\pm 10 ns

Auto Mode

Table 1-73: RS-170A horizontal blanking interval timing

Measurement	Range	Accuracy	Measurement specifications
Color Burst Width	6 cycles to 13 cycles	\pm 0.1 cycles	Horizontal Blanking
Front Porch Duration	0.5 μ s to 2 μ s	\pm 20 ns	Horizontal Blanking
Horizontal Blanking Width	6 μ s to 30 μ s	\pm 50 ns	Horizontal Blanking
Horizontal Sync Rise and Fall Time	80 ns to 120 ns 120 ns to 300 ns 300 ns to 1.0 μ s	-10 to +30 ns \pm 20 ns \pm 30 ns	Horizontal Blanking
Horizontal Sync Width	1 μ s to 8 μ s	\pm 10 ns	Horizontal Blanking
SCH Phase	\pm 90°	\pm 5°	Horizontal Blanking
Sync to Setup	5 μ s to 18 μ s	\pm 20 ns	Horizontal Blanking
Sync to Start of Burst	4 μ s to 8 μ s	\pm 140 ns (0.5 cycles) \pm 20 ns	Horizontal Blanking

Table 1-74: RS-170A vertical blanking interval

Measurement	Range	Accuracy	Test signal
Equalizing Pulse Width	1 μ s to 20 μ s	\pm 10 ns	Vertical Blanking
Serration Width	1 μ s to 20 μ s	\pm 10 ns	Vertical Blanking
Vertical Blanking Width	19 lines to 29 lines	-0.1 line to +0.2 line	Vertical Blanking

Table 1-75: FCC horizontal blanking interval timing

Measurement	Range	Accuracy	Test signal
Breezeway Width	0.2 μ s to 3.5 μ s	\pm 25 ns	Horizontal Blanking
Color Burst Width	6 cycles to 13 cycles	\pm 0.1 cycles	Horizontal Blanking
Front Porch Duration	0.5 μ s to 2 μ s	\pm 10 ns	Horizontal Blanking
Horizontal Blanking Width	6 μ s to 30 μ s	\pm 10 ns	Horizontal Blanking
Horizontal Sync Rise and Fall Time	80 ns to 120 ns 120 ns to 300 ns 300 ns to 1.0 μ s	-10 ns to +30 ns \pm 20 ns \pm 30 ns	Horizontal Blanking
Horizontal Sync Width	1 μ s to 8 μ s	\pm 10 ns	Horizontal Blanking
Sync to Setup	5 μ s to 18 μ s	\pm 20 ns	Horizontal Blanking
Sync to End of Burst	6 μ s to 15 μ s	\pm 20 ns	Horizontal Blanking

Table 1-76: FCC vertical blanking interval timing

Measurement	Range	Accuracy	Test signal
Equalizing Pulse Width	25% to 100% of nominal horizontal sync pulse width	\pm 0.3%	Vertical Blanking
Serration Width	1 μ s to 20 μ s	\pm 10 ns	Vertical Blanking
Vertical Blanking Width	19 lines to 29 lines	-0.1 lines to +0.2 lines	Vertical Blanking

Table 1-77: Amplitude and Phase measurements

Measurement	Range	Accuracy	Test signal
Average Picture Level (APL)	0 to 200%	\pm 3.0%	Full Field
Bar Top	0 to 90% of Maximum Carrier	\pm 0.1%	FCC/NTC-7 Composite
Bar Amplitude	0 to 200 IRE	\pm 0.3 IRE	FCC/NTC-7 Composite
Chrominance to Luminance Delay (Relative Chroma Time)	\pm 300 ns	\pm 5 ns	FCC/NTC-7 Composite
Chrominance to Luminance Gain (Relative Chroma Level)	0 to 160%	\pm 1%	FCC/NTC-7 Composite
Differential Gain	0 to 100%	\pm 0.3%	FCC/NTC-7 Composite

Table 1-77: Amplitude and Phase measurements (cont.)

Measurement	Range	Accuracy	Test signal
Differential Phase	0 to 360°	±0.3°	FCC/NTC-7 Composite
Luminance Non-linear Distortion	0 to 50%	±0.4%	FCC/NTC-7 Composite
Relative Burst Gain	±100%	±0.3%	FCC/NTC-7 Composite
Relative Burst Phase	±180°	±0.3°	FCC/NTC-7 Composite
Burst Amplitude (% of sync)	25% to 200% of sync	±1.0%	Horizontal Blanking
Burst Amplitude (% of Bar)	10% to 80% of Bar (10 IRE to 80 IRE when Bar is not used)	±0.4% (±0.4 IRE)	Horizontal Blanking
Sync Amplitude (% of Bar)	20% to 80% of Bar (20 IRE to 80 IRE when Bar is not used)	±0.3% (±0.3 IRE)	Horizontal Blanking
Blanking Level	0 to 90% of Maximum Carrier	±0.2%	Horizontal Blanking
Sync Variation	0 to 50% of Maximum Carrier (0 to 50% of Bar when Zero Carrier is not used and 0 to 50 IRE when Zero Carrier and Bar are not used)	±0.3% for Zero Carrier (±0.3% for Bar and ±0.3 IRE for no Zero Carrier and no Bar)	Horizontal Blanking
Blanking Variation	0 to 50% of Maximum Carrier (0 to 50% of Bar when Zero Carrier is not used and 0 to 50 IRE when Zero Carrier and Bar are not used)	±0.3% for Zero Carrier (±0.3% for Bar and ±0.3 IRE for no Zero Carrier and no Bar)	Horizontal Blanking

Table 1-78: Frequency Response measurements

Measurement	Range	Accuracy	Test signal
Multiburst Flag Amplitude	0 to 90% of Maximum Carrier (20 to 130% of Bar when Zero Carrier is not used and 20 to 130 IRE when Zero Carrier and Bar are not used)	±0.5% for Zero Carrier (±0.5% for Bar and ±0.5 IRE for no Zero Carrier and no Bar)	FCC Multiburst or NTC-7 Combination
Multiburst Packet Amplitudes	0 to 100% of Flag	±1% of Flag	FCC Multiburst or NTC-7 Combination

Table 1-79: Incidental Carrier Phase Modulation

Measurement	Range	Accuracy	Measurement specifications
ICPM (requires Zero Carrier Pulse and the quadrature output of the demodulator on channel C)	0 to 30°	±1.0°	FCC or NTC-7 Composite

Table 1-80: Color Bar measurements

Measurement	Range	Accuracy	Test signal
Color Bar Amplitude Errors	±100% of nominal	±1.0%	FCC Color Bars
Color Bar Phase Errors	±180° from nominal	±0.5°	FCC Color Bars
Color Bar Chrominance to Luminance Gain Ratio	0 to 200% of nominal	±2%	FCC Color Bars

Table 1-81: Out-of-Service measurements

Measurement	Range	Accuracy	Test signal
Field Time Distortion	0 to 40%	±0.5%	Field Square Wave

Table 1-82: Waveform Distortion measurements

Measurement	Range	Accuracy	Test signal
Line Time Distortion	0 to 40% of Bar	±0.2%	FCC or NTC-7 Composite
Pulse to Bar Ratio	10% to 125%	±0.7%	FCC or NTC-7 Composite
Short Time Waveform Distortion (IEEE 511)	0 to 25% SD	±0.5% SD	NTC-7 Composite
Chrominance Nonlinear Gain Distortion	5 IRE to 35 IRE (20 IRE chroma) 45 IRE to 160 IRE (80 IRE chroma)	±0.4 IRE	NTC-7 Combination
Chrominance Nonlinear Phase Distortion	0 to 360°	±1.0°	NTC-7 Combination
Chrominance to Luminance Intermodulation	±50 IRE	±0.2 IRE	NTC-7 Combination
2T K-Factor	0 to 10% Kf	±0.3% Kf	FCC or NTC-7 Composite

Table 1-83: VIRS measurements

Measurement	Range	Accuracy	Test signal
VIRS Setup (Reference Black)	-20% to +130% of Bar (-20 IRE to +130 IRE when Bar is not used)	±0.2% (±0.5 IRE when Bar is not used)	VIRS
VIRS Chrominance Reference Amplitude	0 to 200% of burst amplitude (0 to 80% of Bar when burst is not used and 0 IRE to 80 IRE when burst and bar are not used)	±1% (±0.1% when burst is not used and ±1 IRE when burst and bar are not used)	VIRS

Table 1-83: VIRS measurements (cont.)

Measurement	Range	Accuracy	Test signal
VIRS Chrominance Phase Relative to Burst	$\pm 180^\circ$	$\pm 0.5^\circ$	VIRS
VIRS Luminance Reference	30% to 100% of Bar (30 IRE to 100 IRE when bar is not used)	$\pm 0.2\%$ (± 0.2 IRE)	VIRS

Table 1-84: Signal-to-Noise Ratio measurements

Measurement	Range	Accuracy	Test signal
Unified Unweighted SNR	26 dB to 60 dB 61 dB to 70 dB	± 1.0 dB ± 2.0 dB	Quiet Line
Unified Luminance Weighted SNR	26 dB to 60 dB 61 dB to 70 dB	± 1.0 dB ± 2.0 dB	Quiet Line
NTC 7 Unweighted SNR	26 dB to 60 dB 61 dB to 70 dB	± 1.0 dB ± 2.0 dB	Quiet Line
NTC 7 Luminance Weighted SNR	26 dB to 60 dB 61 dB to 70 dB	± 1.0 dB ± 2.0 dB	Quiet Line
Periodic SNR	26 dB to 60 dB 61 dB to 70 dB	± 1.0 dB ± 2.0 dB	Quiet Line

Audio Option 40, Option 41, and Option 42 Specifications

The following tables give the specifications for the audio measurements.

Automatic Audio Test Specifications

Table 1-85: O.33 Automatic audio test measurement specifications

Measurement ¹	Range	Accuracy (includes flatness)
Insertion Gain Error ²	±6 dB	±0.2 dB
Sweep Gain (Min and Max)	12 dB	±0.1 dB
THD + N (at 1020 Hz)	≤ 0.03% to 70%	±10% ± 1 digit
2nd Harmonic (at 60 Hz)	≤ 0.03% to 70%	±10% ± 1 digit
3rd Harmonic (at 60 Hz)	≤ 0.03% to 70%	±10% ± 1 digit
Crosstalk (into channel) ³ Test Level:		± 1 dB
+6 dBu	≤ -66 dB to 0 dB	
0 dBu	≤ -60 dB to 0 dB	
-6 dBu	≤ -54 dB to 0 dB	
SNR (unweighted) ⁴ Test Level:		±1 dB
+6 dBu	10 dB to ≥ 76 dB	
0 dBu	10 dB to ≥ 70 dB	
-6 dBu	10 dB to ≥ 64 dB	
SNR (weighted) ^{4,5} Test Level:		±2 dB
+6 dBu	10 dB to ≥ 76 dB	
0 dBu	10 dB to ≥ 70 dB	
-6 dBu	10 dB to ≥ 64 dB	
Max Compandor Error (rise/fall)	±6 dB	±0.2 dB
Gain Difference	12 dB	±0.2 dB
Phase Difference	-180° to 180°	± 1°

¹ Assumes insertion gain is within ± 6 dB.

² The measurement range specification assumes that the input level is within ± 6 dB of the O.33 test level in the audio configuration. The actual O.33 test level range is -6 dBu to +14 dBu.

³ The value for other test levels can be calculated from the formula (-60 - Test Level).

⁴ Measured with Quasi-Peak response as per CCIR 468-4 recommendation. The measurement range can be determined from the formula (70 + Test Level).

⁵ Weighting filter as per CCIR 468-4 recommendation.

Table 1-86: Tektronix automatic audio test measurement specifications

Measurement ¹	Range	Accuracy (includes flatness)
Insertion Gain Error ²	±6 dB	±0.2 dB
Sweep Gain (Min and Max)	12 dB	±0.1 dB
THD + N	≤ 0.03% to 70%	±10% ± 1 digit
Crosstalk (into channel) ² Test Level: +6 dBu 0 dBu -6 dBu	≤ -66 dB to 0 dB ≤ -60 dB to 0 dB ≤ -54 dB to 0dB	±1 dB
SNR (weighted) ³ Test Level: +6 dBu 0 dBu -6 dBu	10 dB to ≥ 90 dB 10 dB to ≥ 90 dB 10 dB to ≥ 84 dB	±2 dB
ANSI Crosstalk (into channel) ²	0 to 10 dB	±0.2dB
ANSI SNR (weighted) ³ Test Level: +6 dBu 0 dBu -6 dBu	10 dB to ≥ 90 dB 10 dB to ≥ 90 dB 10 dB to ≥ 84 dB	±2 dB
Max Compandor Error (rise/fall)	±6 dB	±0.2 dB
Gain Difference	12 dB	±0.2 dB
Phase Difference	-180° to 180°	±1°

¹ Assumes insertion gain is within ± 6 dB.

² The measurement range specification assumes that the input level is within ± 6 dB of the 0.33 test level in the audio configuration. The actual 0.33 test level range is -6 dBu to +14 dBu.

³ The weighting filter is a 15 kHz sharp-cutoff, low-pass filter.

Audio Analyzer Specifications

Table 1-87: Frequency and Noise specifications

Measurement	Specification	Comments
Level Maximum Allowable Input	+30 dBu (24.5 V rms)	

Table 1-87: Frequency and Noise specifications (Cont.)

Measurement	Specification	Comments
Resolution	0.1 dB	
Frequency		
Range	20 Hz to 20 kHz	
Accuracy	± 1 Hz for input ≥ -60 dBu	
Resolution	± 1 Hz for input ≥ -60 dBu	
Phase Difference		
Minimum input level for specified accuracy	-40 dBu	
Phase measurement error	$\pm 1^\circ$ for inputs at 40 Hz to 20 kHz $\pm 2^\circ$ for inputs at 40 Hz to 20 kHz	
Total harmonic distortion & noise (THD+N)		
Measurement bandwidth	33 Hz to 22 kHz	
Input level	≥ -20 dBu	
Residual THD+N	$\leq 0.03\%$	
Maximum measurement	70.0%	
Accuracy	$\pm 10\%$ of reading ± 1 digit for harmonics	
Channel Separation		
Measurement Window	± 24 Hz	Measurement is taken in the undriven channel. The measurement window follows the driven channel signal frequency.
20 Hz to 350 Hz	± 96 Hz	
>350 Hz	Constant bandwidth	
Measurement Filter		
Plot Mode		
Minimum frequency change	± 2 Hz	
Minimum dwell time	1 sec for input frequencies < 500 Hz; 500 ms for input frequencies ≥ 500 Hz	

Table 1-88: Accuracy and Flatness specifications

Frequency range	Level range ¹	Accuracy (includes flatness)	Flatness
20-40 Hz	≥ -20 dBu	+ 0.3 / -0.2 dB	+ 0.1 / -0.2 dB
	-20 dBu to -50 dBu	+ 0.4 / -0.3 dB	+ 0.1 / -0.2 dB
	-50 dBu to -60 dBu	+ 0.6 / -0.5 dB	+ 0.1 / -0.2 dB
	-60 dBu to -70 dBu	± 1.0 dB	+ 0.1 / -0.2 dB
40 Hz-20 kHz	≥ -20 dBu	± 0.2 dB	± 0.1 dB
	-20 dBu to -50 dBu	± 0.3 dB	± 0.1 dB
	-50 dBu to -60 dBu	± 0.5 dB	± 0.1 dB
	-60 dBu to -70 dBu	± 1.0 dB	± 0.1 dB

¹ Level differences between channels is ± 0.2 dB at levels of -50 dBu and greater.

Audio Spectrum Specifications

Table 1-89: General Audio Spectrum specifications

Description	Specification	
	Normal Res mode	High Res mode
Display bandwidth	DC to 24 kHz	Any 3 kHz within the display bandwidth
Frequency resolution	47 Hz	6 Hz
Cursor readout accuracy		
Frequency	± 24 Hz	± 3 Hz
Amplitude	+ 0.5 dB / -1.0 dB	+ 0.5 dB / -1.0 dB
Frequency range for noise level measurement	188 Hz to 20 kHz	Selected 3 kHz window within the range of 24 Hz to 24 kHz
Signal/Noise ratio	> 85 dB (at full scale) > 70 dB (for inputs > -20 dBu with appropriate range selection)	

Table 1-90: Audio Spectrum Level measurement specifications

Frequency range	Level range	Accuracy	Flatness
188 Hz -20 kHz	≥ -20 dBu	± 0.2 dB	± 0.1 dB
	-20 dBu to -50 dBu	± 0.3 dB	± 0.1 dB
	-50 dBu to -60 dBu	± 0.5 dB	± 0.1 dB
	-60 dBu to -70 dBu	± 1.0 dB	± 0.1 dB

Table 1-91: Harmonic Analyzer measurement specifications

Description	Specification	Comments
Highest Fundamental Frequency	9999 Hz	Harmonics up to the 20 kHz measurement bandwidth are displayed.
Measurement Update Rate	6 readings per second	
View Harmonic Measurement Window	± 24 Hz	All signal energy within the view window is measured.

Table 1-92: Miscellaneous specifications

Description	Specification
Channel separation/crosstalk	> 100 dB ¹ , 20 Hz to 20 kHz
Input connectors	
Option 40	Two mini-XLR (Switchcraft® TY3F); requires Switchcraft TA3M mini-XLR plug Two mini-XLR to XLR female adapters and two mini-XLR male plugs are supplied.
Option 41	One male DB-37 connector. One DB-37 female connector is supplied.
Input impedance	50 k Ω , balanced, differential

¹ Noise limited, source impedance for both channels is $\leq 600 \Omega$.

Multitone Analyzer Specifications

Table 1-93: Multitone Analyzer measurement specifications

Description	Specification	Comments
Level of Individual Tones Relative to Multitone RMS Level		
Multitone 1	-19.9 dB	
Multitone 2	-18.9 dB	
Multitone 3	-13.8 dB	
Multitone 4	-15.9 dB	
Reference Frequency for Multitone Recognition		
Multitone 1	422 Hz	
Multitone 2	562 Hz	
Multitone 3	656 Hz	
Multitone 4	750 Hz	

Table 1-93: Multitone Analyzer measurement specifications (cont.)

Description	Specification	Comments
Minimum Amplitude of Reference Tone for Multitone Recognition Input Range Window		
A	-10 dBu	
B	-20 dBu	
C	-30 dBu	
D	-40 dBu	
E	-50 dBu	
AUTO RANGE	-50 dBu	
Minimum Multitone Recognition Time (first time)	1 second	
Measurement Update Rate After Recognition	5 readings per second	
Maximum Frequency Error for Multitone Recognition	Within $\pm 10\%$ of reference frequency	
Level Measurement Accuracy	Same as Audio Analyzer	
Frequency Measurement Accuracy	Same as Audio Analyzer	

A/V Timing Specifications (Option 42)

Table 1-94: Audio/Video Timing measurement specifications

Characteristic	Performance requirement
Audio Amplitude Window	92 dB
Audio Amplitude Range	-102 dB to +30 dB in five ranges
Timing Range	± 65 ms
Timing Accuracy	± 1 ms

Option 48 GPIB Specification

The GPIB interface function set implemented in the VM700T GPIB interface and the capability level is given in Table 1-95.

Table 1-95: IEEE 488.1 interface functions implemented in the VM700T GPIB interface card

Function	Implemented	Notes
Source Handshake	SH1	Complete capability
Acceptor Handshake	AH1	Complete capability
Talker	T6	Basic Talker, Serial Poll, Unaddr if MLA
Talker (extended)	TE0	No capability
Listener	L4B	Basic Listener, Unaddr if MTA
Listener (extended)	LE0	No capability
Service Request	SR1	Complete capability
Remote Local	RL2	No local lock out
Parallel Poll	PP0	No capability
Device Clear	DC1	Complete capability
Device Trigger	DT0	No capability
Controller	C0	No capability
Electrical Interface	E2	Three-state bus drivers

Table 1-96: GPIB Electrical characteristics

Characteristic	Performance requirement	Comments
Output Signal Levels	Logical 0 $\geq +2.0$ V Logical 1 $\leq +0.8$ V	IEEE Std 488-1979 para. 3.2
Data Transfer Rate	Greater than 1 kbyte per second	
Connectors		
GPIB	Standard GPIB parallel connector	
VM700T	3 \times 50 square pin connector	Connects to VM700T inter-connection board
Power Requirements		
+5 V		
Power Consumption	35 W maximum	
Fuse		
+5 Vin	10 A, fast blow	Located on the GPIB module

Table 1-97: Mechanical specifications

Characteristic	Description
Construction	Plug in circuit board. Designed for installation in the VM700T left side card cage. Multilayer ECB; material FR4.
Dimensions	
Length	11 inches (279.4 mm) (includes board retainer)
Width	7.785 inches (200 mm) (includes VM700T connector)
Height	1 plug in unit high (15/16 inch) (23.8 mm)
Shipping Weight	Approximately 4 lb (includes GPIB board, manual, and packing materials)

Table 1-98: Optional accessories

Item	Description
GPIB Cable	1 m, double-shielded. Tektronix Part No. 012-0991-01 2 m, double-shielded. Tektronix Part No. 012-0991-00 3 m, double-shielded. Tektronix Part No. 012-0991-02
GURU II+. GPIB User's Resource Utility for the IBM Personal Computer	Software and manual plus National PC2A GPIB controller board and GPIB cable Tektronix Product No. S3FG100

Option 1S SDI Specification

The specifications for Option 1S are the same as those listed for the VM700T Video Measurement Set except where listed below. The following specifications are only valid when Option 1S is installed in a VM700T.

Table 1-99: SDI Eye Diagram application

Characteristic	Performance requirement	Supplemental information
Eye Diagram Measurements		Measurements performed on SDI Ch. A input signals only
Amplitude Accuracy		
10° C to 35° C ambient	± 5% for signals between 600 mV _{p-p} and 1 V _{p-p}	

Table 1-99: SDI Eye Diagram application (cont.)

Characteristic	Performance requirement	Supplemental information
Full temperature range	$\pm 10\%$ for signals between 600 mV _{p-p} and 1 V _{p-p}	
20% to 80% Rise Time Accuracy	± 100 ps for rise times between 400 ps and 1.5 ns	
Signal Aberrations	$< 5\%$ for 800 mV _{p-p} step with ≥ 400 ps rise time	
Noise Floor		
Amplitude		10 mV tangential noise
Timing		< 100 ps tangential noise
DC Offset Accuracy		10 mV $\pm 2\%$ of reading from -1 V to +1 V
Filter Performance		
10 Hz filter		-3 dB at 10 Hz
1 kHz filter		-3 dB at 1 kHz

Table 1-100: SDI Jitter application

Characteristic	Performance requirement	Supplemental information
Jitter Measurements		Measurements performed on SDI Ch. A input signals only
Maximum Amplitude		
143 Mb/s		3 ns pk-to-pk for frequencies of 0.5 MHz and above Max jitter (ns) = 1500 \div jitter frequency (kHz) for frequencies below 0.5 MHz
270 Mb/s	1 ns pk-to-pk for frequencies of 1.5 MHz and above Max jitter (ns) = 1500 \div jitter frequency (kHz) for frequencies below 1.5 MHz	1.2 ns pk-to-pk for frequencies of 1.25 MHz and above typical Max jitter (ns) = 1500 \div jitter frequency (kHz) for frequencies below 1.25 MHz typical
360 Mb/s		0.9 ns pk-to-pk typical frequencies of 1.33 MHz and above Max jitter (ns) = 1200 \div jitter frequency (kHz) for frequencies below 1.33 MHz
Frequency Response of Jitter-Waveform and Spectrum displays		
143 Mb/s	± 3 dB to 0.5 MHz; +3 dB to -5 dB at 3 MHz	

Table 1- 100: SDI Jitter application (cont.)

Characteristic	Performance requirement	Supplemental information
270 Mb/s, 360 Mb/s	± 3 dB to 5 MHz; +3 dB to -6 dB at 10 MHz	-3 dB at 8 MHz typical
Timing & Alignment Jitter Readout Accuracy		
143 Mb/s	200 ps $\pm 20\%$ of actual for components from 50 Hz to 1 MHz 200 ps +20%, -30% of actual for components from 1 MHz to 3 MHz	100 ps $\pm 5\%$ of actual for components from 50 Hz to 1 MHz typical
270 Mb/s, 360 Mb/s	200 ps $\pm 20\%$ of actual for components from 50 Hz to 1 MHz 200 ps +60%, -30% of actual for components from 1 MHz to 10 MHz	100 ps $\pm 5\%$ of actual for components from 50 Hz to 1 MHz typical

Table 1- 101: SDI Wander application

Characteristic	Performance requirement	Supplemental information
Wander Measurements		Measurements performed on SDI Ch. A input signals only
Frequency Range		
143 Mb/s	± 20 ppm	
270 Mb/s	± 20 ppm	
360 Mb/s	± 20 ppm	
Frequency Accuracy	± 0.1 ppm	
Drift Rate Range	± 40 ppm/s	
Drift Rate Accuracy	± 5 ppb/s	

Table 1- 102: SDI Interchannel Timing application

Characteristic	Performance requirement	Supplemental information
Digital-to-Digital		
Accuracy	± 1 sample	
Range	± 0.5 frame	
Digital-to-Analog		
Accuracy	± 400 ns	
Range	± 0.5 frame	

Table 1-103: SDI Audio/Video Timing application

Characteristic	Performance requirement	Supplemental information
Embedded Signal		
Accuracy	$\pm 200 \mu\text{s}$	
Range		± 2 seconds; less range on data streams heavily loaded with ancillary data
External Signal		
Accuracy	$\pm 200 \mu\text{s}$	
Range		± 2 seconds

Table 1-104: SDI Ch. A Input

Characteristic	Performance requirement	Supplemental information
Electrical Characteristics		
Input type	BNC passive loopthrough; 75 Ω compensated	
Return Loss		
Power On	≥ 25 dB, 1 MHz to 360 MHz	Channel on or off
Power Off	≥ 15 dB, 1 MHz to 360 MHz	
Insertion Loss		
Power On	< 0.3 dB, 1 MHz to 360 MHz	
Power Off	< 1.0 dB, 1 MHz to 360 MHz	
Signal Characteristics		
Amplitude Range	800 mV; +15%, -25%	
Frequency Range		
143 Mb/s	± 20 ppm	
270 Mb/s	± 20 ppm	
360 Mb/s	± 20 ppm	
Jitter Maximum for No Bit Errors		
143 Mb/s		2 ns pk-to-pk for frequencies of 160 kHz and above Max jitter (ns) = $320 \div$ jitter frequency (kHz) for frequencies below 160 kHz
270 Mb/s		1 ns pk-to-pk for frequencies of 160 kHz and above Max jitter (ns) = $160 \div$ jitter frequency (kHz) for frequencies below 160 kHz
360 Mb/s		0.8 ns pk-to-pk for frequencies of 160 kHz and above Max jitter (ns) = $130 \div$ jitter frequency (kHz) for frequencies below 160 kHz
Cable Length Maximum for No Bit Errors	Equivalent to 200 meters of Belden 8281 cable	Equivalent to 250 meters of Belden 8281 cable typical

Table 1-105: SDI Ch. B Input

Characteristic	Performance requirement	Supplemental information
Electrical Characteristics		
Input type	BNC; 75 Ω terminated	
Return Loss		
Power On	≥ 25 dB, 1 MHz to 360 MHz	Channel on or off
Power Off	≥ 15 dB, 1 MHz to 360 MHz	
Signal Characteristics		
Amplitude Range	800 mV; +15%, -25%	
Frequency Range		
143 Mb/s	± 20 ppm	
270 Mb/s	± 20 ppm	
360 Mb/s	± 20 ppm	
Jitter Maximum for No Bit Errors		
143 Mb/s		2 ns p-p for frequencies of 160 kHz and above Max jitter (ns) = $320 \div$ jitter frequency (kHz) for frequencies below 160 kHz
270 Mb/s		1 ns p-p for frequencies of 160 kHz and above Max jitter (ns) = $160 \div$ jitter frequency (kHz) for frequencies below 160 kHz
360 Mb/s		0.8 ns p-p typical for frequencies of 160 kHz and above Max jitter (ns) = $130 \div$ jitter frequency (kHz) for frequencies below 160 kHz
Cable Length Maximum for No Bit Errors	Equivalent to 200 meters of Belden 8281 cable	Equivalent to 250 meters of Belden 8281 cable typical

Table 1-106: LTC Input

Characteristic	Performance requirement	Supplemental information
Electrical Characteristics		
Input type	Miniature XLR	
Input Impedance		> 10 k Ω
Signal Characteristics		
Format	Longitudinal Time Code per IEC pub. 461	

Table 1-107: SDI Output

Characteristic	Performance requirement	Supplemental information
Electrical Characteristics		
Output type	BNC; 75 Ω compensated	
Return Loss		
Power On	≥ 25 dB, 1 MHz to 360 MHz	Channel on or off
Power Off	≥ 15 dB, 1 MHz to 360 MHz	
Signal Characteristics		
Amplitude	800 mV _{p-p} $\pm 10\%$	
20% to 80% Rise/Fall Time	400 ps to 800 ps	

Table 1-108: Analog Ref. Input

Characteristic	Performance requirement	Supplemental information
Electrical Characteristics		
Input type	BNC passive loopthrough; 75 Ω compensated	
Return Loss	≥ 30 dB, 50 kHz to 6 MHz	Power on or off
Signal Characteristics		
Amplitude Range	± 6 dB with respect to 1 V _{p-p} video	

Table 1-109: AES Audio Input

Characteristic	Performance requirement	Supplemental information
Electrical Characteristics		
Input type	BNC; 75 Ω	
Return Loss		> 15 dB, 0.1 MHz to 6 MHz
Signal Characteristics		
Amplitude Range		0.2 V _{p-p} to 2 V _{p-p}
Format	AES/EBU digital-audio per AES3-1992 (ANSI S4.40-1992)	

Table 1-110: Environmental specification

Characteristic	Performance requirement	Supplemental information
Maximum operating temperature	45° C	VM700T with Option 1S installed

Operating Information

The VM700T Video Measurement Set is a multi-function television test and measurement device with an easy to use interface. The measurement set performs the functions of a waveform monitor, vectorscope, automatic measurement set, and a noise measurement set on acquired television signals. The measurement set does measurements on video signals obtained from either live TV signals (broadcast or cable) or television test equipment. You can select numeric value displays to confirm signal path quality or graphic displays for more detailed analysis of the applied signal.

The measurement set can be operated directly using the front panel or remotely using one of the RS-232C ports on the rear panel.

Installation

The standard measurement set is a rack mounted unit. Refer to the *VM700T Rack Mounting Instructions* on page 6-44 for the rack mounting installation instructions. The following unpacking and power requirements information is repeated there. You can also order the measurement set as a cabinet style unit.

Unpackaging

When you unpackage the measurement set, keep the shipping carton and packaging material. If you need to return the measurement set for servicing, you will then have packaging available that provides adequate protection for shipment.

Power Requirements

The VM700T Video Measurement Set operates with line frequencies of 50 Hz or 60 Hz, over two line voltage ranges. The nominal setting of the low voltage range is 115 VAC. The nominal setting of the high voltage range is 230 VAC. There are two power switches on the measurement set.

- The main power switch is on the rear panel above the power cord receptacle.
- The Stby/On switch is on the front panel.

Both power switches must be on to operate the measurement set.



WARNING. *Dangerous voltages are present within the Power Supply module when the rear-panel power switch is on, regardless of the position of the front-panel power switch. Do not operate the measurement set with any covers removed. Refer all servicing of the measurement set to a qualified service person.*

Changing Line Voltage Range and Fuse

The voltage range selection switch and fuse holder are located in the lower left corner of the rear panel (see Figure 2-10 on page 2-16). The measurement set is shipped from the factory set to the operating voltage of the destination (115 VAC or 230 VAC).

If the setting is not correct, you must change it before connecting the power cord to the power source. Set the voltage range selection switch (located on the rear panel of the measurement set) to the correct position for operation.



CAUTION. *When changing the line voltage selector switch you must also change the fuse to provide proper protection for the operating voltage in use. The 3A slow-blow fuse provides the proper protection in the 230 VAC range and the 6A slow-blow fuse provides protection for operation in the 115 VAC range.*

Power Cord

A detachable three-wire power cord with a three-contact plug is provided with each measurement set for connecting to both the power source and protective ground. The protective-ground connector in the plug connects (through the protective-ground conductor) to the accessible metal parts of the measurement set. For electrical-shock protection, insert this plug only into a power-source outlet that has a properly grounded protective-ground contact.

Measurement sets are shipped with the power cord required for the country of destination. Refer to the *Options* section for information on the available power-cord options. European power cord options A1 and A2 require an additional accessory for operation in the EU countries. When the VM700T Video Measurement Set is ordered with either the A1 or the A2 power cord option, the VM700T Power Line Conditioning accessory is also provided.

Power Line Conditioner Accessory

The Power Line Conditioner accessory to the VM700T assures that the VM700T meets the Line Harmonics requirements of the European Union when operated from a 230 Vac mains source.

The line conditioner is for use only with the VM700T when operating the VM700T from a 230 Vac mains source. The Power Line Conditioner provides no benefit when the VM700T is operated from a 120 Vac mains source and should NOT be used.

NOTE. *The VM700T will not be damaged if operated from a 230 Vac mains source without the Power Line Conditioner connected to the power input.*

Installing the Power Line Conditioner

The Power Line Conditioner can be used with either with a rackmounted VM700T or a standalone VM700T on a benchtop.

Rackmounted VM700T. Use the mounting bracket and screws provided with the accessory to attach the box to a rackmount rail. Use only #10 screws for the screw holes in the box. Place the box in any convenient location within the rack where you can make the power-cord connections (see Figure 2-1).

NOTE. Do not mount the power line conditioning box in any location that blocks the air flow (in or out) of the VM700T or any other product installed in the rack.

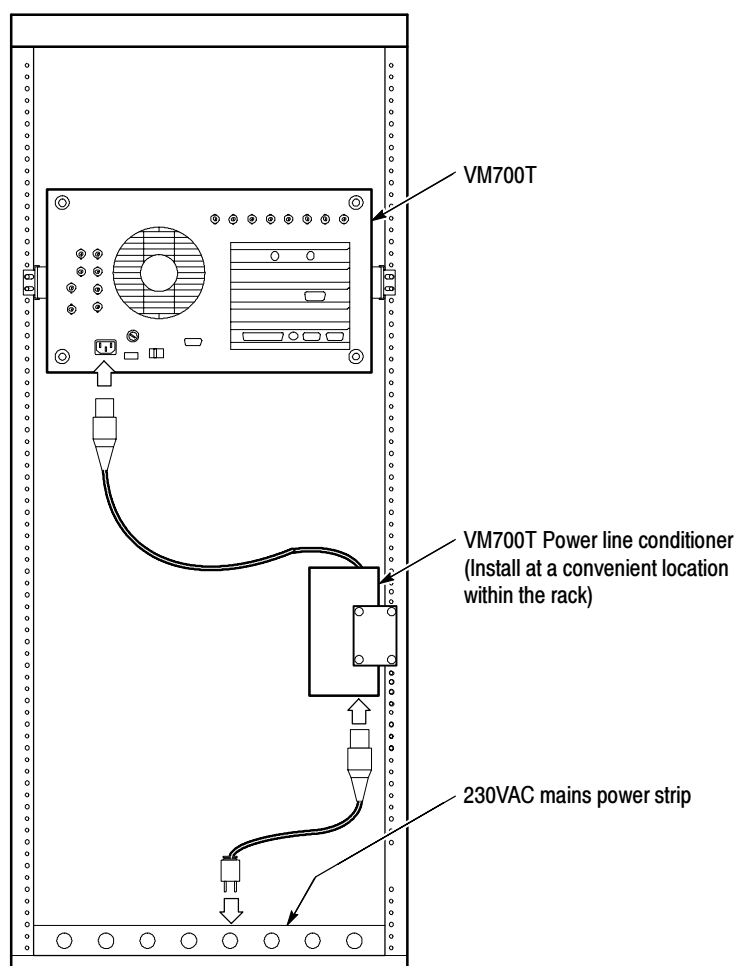

Figure 2-1: Power line conditioner with a rackmounted VM700T

Benchtop Mounting. For a standalone VM700T on a benchtop or for portable use, apply the four adhesive rubber feet provided with the accessory to the bottom of the box at the corners. Place the conditioner box in a convenient location where you can make the power cord connections.

Power Cord Connections. Connect the Power Line Conditioner in the power line between the AC mains and the VM700T power input connector in the following order:

1. Plug the output power cord connected to the box into the AC power input connector of the VM700T.
2. Plug the AC mains power cord into the AC input connector of the power line conditioner box.
3. Plug the AC mains power cord into the 230 Vac mains source.

Power On Diagnostics

The measurement set, as shipped from the factory, is configured to skip diagnostics at power on for a quicker start up. You can run diagnostics at power on by doing an Auto Reset. Refer to *Auto Reset* on page 6–84 for information on forcing an Auto Reset. If any of the diagnostic tests fail, refer your measurement set to a qualified service person.

You may want to access the diagnostics for a couple of operating selections. These are setting the power on run mode (either to run the diagnostics at power on or to skip them for a quick start) and calibrating the touch screen.

Calibrating the Touch Screen

The measurement set is shipped from the factory with its touch screen fully calibrated. However, if you notice misregistration of the touch screen, you can recalibrate it. Use the following procedure to calibrate the touch screen:

1. Switch off power to the measurement set at the front panel.
2. Press and hold the Menu button while turning on the power. After the measurement set beeps twice to acknowledge the startup mode, release the Menu button. The measurement set then initializes into the Low Level Diagnostics Interface with the VM700T Startup Menu (see Figure 2-2).

```

Low Level Diagnostic Interface
(knob moves cursor, "Select Line" inputs selection)

--- VM700T STARTUP MENU ---
Key   Selection
-----
R ... Instrument -RUN MODES- Menu
U ... -UTILITIES- Menu
D ... Low Level -DIAGNOSTICS- Menu
C ... Diagnostics -CONFIGURATION- Menu
H ... Diagnostics -HELP- Menu
T ... Calibrate -TOUCH PANEL INTERFACE-
-----
= ... Reprint           @ ... Abort Menu
-----

Input your selection:

```

Figure 2-2: VM700T Startup menu

3. Use the large control knob to highlight the T in the Calibrate Touch Panel Interface line of the VM700T startup menu. Press the Select Line button to make the selection to calibrate.
4. The first touch screen calibration instructions are then displayed as shown in Figure 2-3. Follow the written directions. Pressing AUTO aborts the calibration process and returns you to the startup menu. Pressing any other button stores the setting in NVRAM and brings up the next touch screen calibration menu.

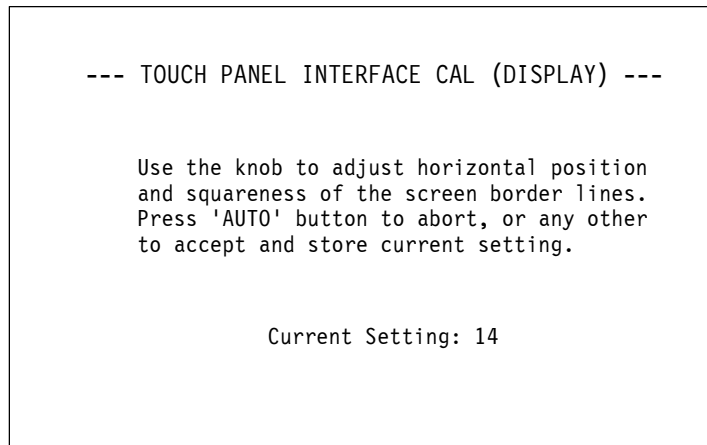

Figure 2-3: Touch screen calibration (display)

5. After making the adjustment requested and storing the current setting, the VM700T displays a second set of instructions as shown in Figure 2-4. Follow the directions given in the screen.

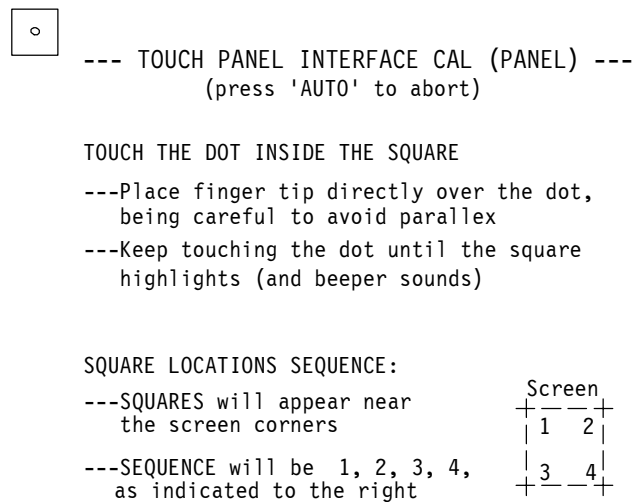

Figure 2-4: Touch screen calibration (panel)

- After you have touched the dots at all four corners, a screen showing the panel calibration factors is displayed (see Figure 2-5). From that screen, you can press any key to return to the startup menu.

```

--- PANEL CALIBRATION VALUES ---

XSCALE = 471      XOFFSET = 292
YSCALE = -398     YOFFSET = 231

-#- Press Any Key to Continue -#-

```

Figure 2-5: Panel calibration values

NOTE. Panel calibrations values vary greatly depending on the version of touch panel that is installed in your instrument. The sample values shown are typical of an older touch panel.

Setting the Power On Mode

You can configure the measurement set to always skip the power on diagnostics or to always run them at power on. To access the diagnostics menus:

- Press and hold the Menu button while turning on the power to display the VM700T Startup menu (shown in Figure 2-2 on page 2-5). In the startup menu, highlight the C in the Diagnostic Configuration line and press the Select Line button. This brings up the Diagnostics Configuration menu shown in Figure 2-6.

```

          Low Level Diagnostic Interface
(knob moves cursor, "Select Line" inputs selection)

          --- DIAGNOSTICS CONFIGURATION MENU ---
Key      Selection
-----
P ... Set Diagnostics -POWERUP MODE-
I ... Set Diagnostics -INTENSITIES-
B ... Set Low Level Diagnostics Console -DEFAULT BAUD RATE-
-----
= ... Reprint           @ ... Abort Menu
-----

Input your selection:

```

Figure 2-6: Diagnostic configuration menu

2. In Diagnostics Configuration menu, highlight and select P in the Set Diagnostics Powerup Mode line to bring up the powerup mode choices shown in Figure 2-7.
3. In the Set Diagnostics Powerup Mode menu, either highlight and select Q to have the measurement set skip diagnostics on power up or highlight and select P to have the measurement set run diagnostics on power up. (The other choices in the menu are used in diagnostic testing in manufacturing and factory service.)

Your selection is stored in the diagnostics NVRAM.

4. Turn the VM700T off and back on again to restart normal operation.

```

                Low Level Diagnostic Interface
                (knob moves cursor, "Select Line" inputs selection)

                --- SET DIAGNOSTICS POWERUP MODE ---

                Select a Powerup Mode from the list below. The mode selected will be
                stored in Diag NVRAM and will be effective for -NORMAL- powerups
                (ie: Boot Switches in NORMAL position). The current Powerup Mode
                setting is -STARTUP MENU-.

Key   Selection
-----
Q ... QUICK START ..... Skip Diagnostics, start Instrument
M ... STARTUP MENU ..... Goto VM700T Startup Menu
P ... POWERUP DIAGS ..... Do Diagnostics, start Instrument
L ... LOW LEVEL DIAGS LOOP ..... Loop on Low Level Diagnostics
D ... HIGH LEVEL DEBUG ..... Run Instrument in DEBUG MODE
-----
= ... Reprint                               @ ... Abort Menu
-----

Input your selection:
    
```

Figure 2-7: Set diagnostics power up mode menu

Measurement Set Operating Modes

The measurement set has multiple operating modes. These modes provide different measurements and different means of making measurement. The following information explains each of the operating modes.

Waveform Mode

For detailed waveform analysis, you can display the actual signal and take additional measurements manually. In Waveform mode, cursors are available to aid in measuring time, frequency, and amplitude. These cursors allow precise location of 10, 50, and 90 percent points on any transition.

You can expand the waveform display around any vertical or horizontal point. Since the data is digitized, the display is bright at all expansion factors. The axes automatically expand with the waveform, so all units are correct as displayed.

Vector Mode The Vector mode provides the normal vectorscope display. You can rotate or expand the vectors; the rotation angle and gain values are displayed numerically on the screen.

A unique “Find Colorbars” feature searches the video signal for color bars and displays the vectors if it finds a color bars test signal. You can use the Select Line choice in both Waveform mode and Vector mode to quickly specify any line for display or automatic measurement if an appropriate video test signal is being measured.

Measure Mode Measure mode provides graphic displays of measurements such as noise spectrum, group delay, and K-factor, for adjustment or closer analysis of the measurement. You can make relative-to-reference measurements against a stored reference to minimize or eliminate signal source errors. Signal averaging can be used to reduce the effects of random noise in measurements where averaging is appropriate.

Picture Mode Picture mode permits you to quickly verify the signal source. You can select any line on the picture to view in either the waveform display or the vector display for analysis of that line.

Auto Mode Auto mode makes standardized video measurements automatically, including those specified in the RS-250B/EIA-250C, NTC-7, and RS-170A video signal standards. You can select the limits used on the measurements to determine out-of-limits conditions. The measurement set generates a caution or alarm message if a measurement falls outside the selected limits. You can select the format for the auto mode measurement reports and schedule the report printing times.

Analog/Digital Mode (Option 1S Only) If your measurement set has Option 1S installed, the VM700T resembles two separate instruments in one package: one analog and one digital. You can switch between the analog and digital functions by selecting Digital Mode or Analog Mode from one of these locations: the Configuration menu (two locations), the Measure menu, or through remote control.

NOTE. To access any of the functions of Option 1S, you must set the VM700T to Digital Mode. To access any of the analog measurement applications of the VM700T, you must set the VM700T to Analog Mode.

When you switch between Digital Mode and Analog Mode, the operation of the front-panel buttons does not change except for the following five buttons: Waveform, Vector, Picture, Measure, and Auto. The Waveform and Picture buttons access the SDI Waveform and the SDI Picture applications respectively. The Vector button accesses the SDI Lightning application. The Measure mode button operation changes so that the measurement choices shown in the Measure menu will be only those relevant to the selected signal source type (analog or digital). When the VM700T is set to Digital Mode, the Auto mode button provides direct access to the SDI Format Monitor application.

Option 1S adds a new soft key to the Measure mode screen and changes the name of one of the existing soft keys. The new SDI soft key changes the measurement set to Digital Mode and displays the SDI applications. The original Video soft key is renamed to Analog Video. The Analog Video soft key changes the measurement set to Analog Mode and displays the analog measurement applications.

User-Programmable Functions

You can define a sequence of operations as a new function. For example, you can create a function that makes the measurements on a transmitter demodulator video output. You can label this function DEMOD, build it to make all the measurements, and provide a printout of the results. You can also call another function from within a function to produce a set of measurements.

Hardcopy

You can use a printer that supports PostScript or 24-pin Epson graphics through the standard RS-232C interface to hard copy the on-screen information. You can use most types of ASCII printers to print the results of Automatic measurements using the same interface. You can also send hard copy output to a parallel printer through the Centronics-compatible parallel printer port.

Remote Operation

The measurement set can be operated from a remote terminal through either of the RS-232C ports to monitor unattended transmission systems or to put systems under computer control. The VGA output connector on the rear panel provides a copy of the measurement set display for remote viewing on a standard VGA monitor. A GPIB port is added for remote control or hard-copy output to a GPIB printer with Option 48 installed.

Front Panel Controls

The front panel controls (shown in Figure 2-8) consists of a touch screen interface and a 20-button keypad with a control knob.

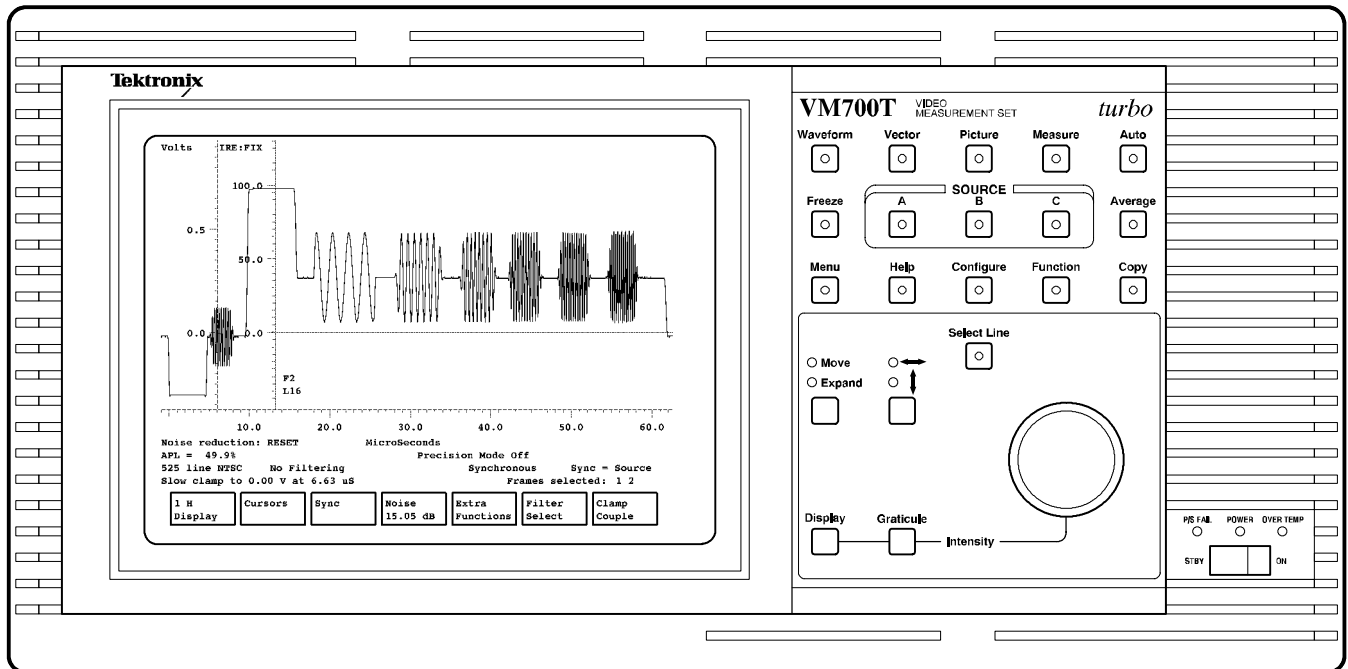

Figure 2-8: The VM700T Video Measurement Set front panel

Touch Screen The display (CRT) area of the measurement set has a touch screen interface for communicating with the measurement set. You touch the soft keys on the screen to select and control many operations of a running application. When applicable, you can change selection values within a soft key by rotating the large control knob. You also use the touch screen interface to edit the configuration files that control the operation of the measurement set. The place you touch the screen is also the zoom point for expanding or contracting a displayed waveform.

Keypad The keypad (shown in Figure 2-9) contains three five-button rows, plus an additional five buttons associated with the control knob.

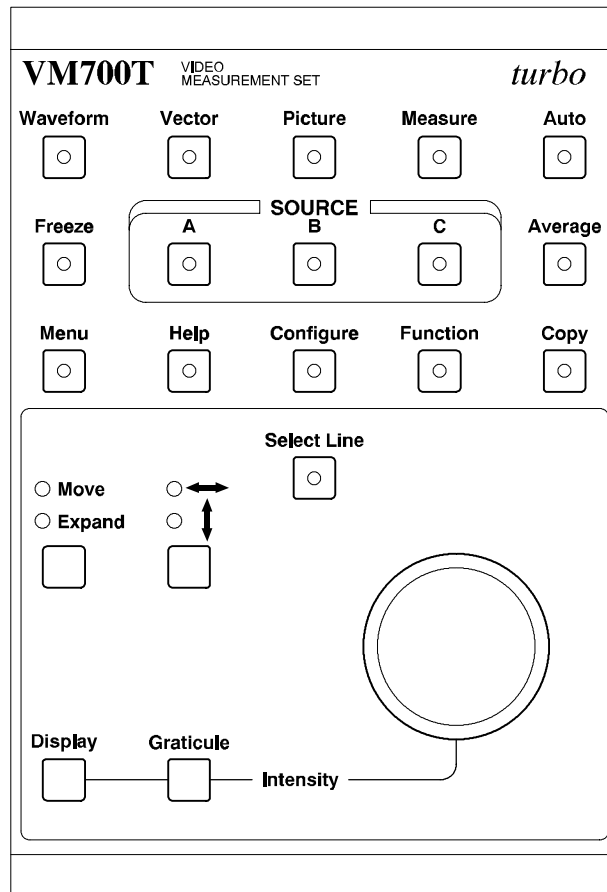

Figure 2-9: Measurement set keypad

Manual and Auto Operational Modes. The top row of buttons selects the major functions (operating modes) of the measurement set. The measurement set has five operational modes: four manual modes and an automatic mode, and it operates in one of these modes whenever it is on. The manual modes are Waveform, Vector, Picture, and Measure; the automatic mode is Auto. The power-on default mode is Waveform.

The manual modes perform the specified operation and provide a graphic display with digital readouts and status information. Auto mode makes measurements automatically and provides a tabular listing of the measurement results. You can get measurement results reported in either mode. Parameters such as clamping, sync source, and the displayed line (system line) are common for all the manual modes of operation.

NOTE. *Manual mode parameters do not carry over to Auto mode. You must set parameters for both the Auto mode and the manual modes. The parameter files are reached through the directory and file structure accessed by the Configure button.*

Freeze, Source Selection, and Average Functions. The second row in the keypad contains the Freeze button, the input channel selection buttons (grouped as SOURCE A, B, and C), and the Average button.

- **Freeze Button.** When you select Freeze, signal acquisition is halted. The display can be moved, expanded or contracted, as described below under Control Knob, but the display is not updated.
- **Source Selection Button.** For all operational modes, one of the input sources is always selected. For some of the manual modes, an input source can be inverted. In Waveform and Vector modes, an inverted source can be the sole input or it can be added to another input. In Measure mode, an inverted source can only be added to another source.
- **Source Invert.** To invert a single source, press and hold the source button until the measurement set beeps (approximately one second). When a source is inverted, the LED on the source button flashes. To invert a second source and add it to another, press and hold the normal source and, while holding it, quickly press and release the inverted source. The LED on the inverted source will flash.
- **Average Button.** The Average button enables uncorrelated or random noise reduction on the signal in Waveform and Vector modes and averaging of the signal in Measure mode. The amount of noise reduction (up to 30.10 dB) is set with the Noise soft keys. The number of averages (up to 256) is set with the Average Num soft keys.

Support Functions. The third row down in the keypad contains support functions: Menu, Help, Configure, Function, and Copy. Turn any of these functions on by pressing the associated front-panel button. Of these, Copy turns off either after the copy is sent or after pressing the Cancel soft key that appears in the Configure menu when a copy is pending. Help is turned off by pressing the Help button a second time. The remaining functions are turned off either by pressing the button a second time or by selecting a different operational mode in the top row.

- **Menu Button.** The Menu button displays a menu of soft keys across the bottom of the touch screen. In some cases, touching a soft key displays a further submenu of soft keys.

- **Help Button.** Pressing the Help button activates the Help function. While Help is activated, pressing a button or selecting a soft key displays a brief explanation of that button or soft key's function. When the Help function is active, all buttons and soft keys except Help lose their normal function, and the LED on the Help button flashes. Pressing the Help button a second time turns off the Help function.
- **Configure Button.** Configure accesses the Configuration files used to control the operation of the measurement set. You can also create, edit, rename, print, and delete functions with selections available in the Configuration menu. For a full description of the Configure button and the menus accessed, refer to the *VM700T Option 01 (NTSC) and Option 11 (PAL) User Manual*.
- **Function Button.** The Function button accesses user-created functions and the selection choices for running them. For a full description of creating and editing functions, refer to the *VM700T RS-232 Interface Programmer Manual*.
- **Copy Button.** The Copy button sends a copy of the display (in user-selectable 24-pin Epson or PostScript format) to the measurement set print spooler to queue for printing.

The LED in the Copy button flashes as long as the copy remains in the spooler. To delete the copy from the spooler, press the Configure button, and select the Cancel Copy soft key. This soft key only appears when a copy is pending in the spooler.

To print the spooled copy, a suitable printer must be attached to one of the measurement set serial ports or to the parallel printer port. You also have to set the Communications configuration file parameters to those needed for the attached printer.

Control Knob

The action of the control knob depends on its assignment for the current mode of operation. For example, in Waveform mode, rotating the control knob affects horizontal or vertical movement of the display or horizontal or vertical expansion of the display, depending on the selections of the Move/Expand button and the "left/right/up/down" button. In Auto mode, rotating the control knob scrolls through the list of measurements. When a user-configurable parameter is selected for changing, you can rotate the control knob to make the change. For information on the specific functions of the control knob in each mode, refer to the relevant sections of the user documentation.

- **Display and Graticule Intensity Control.** To change the intensity of either the display or the graticule, hold down the appropriate button (Display or Graticule), and rotate the control knob.

- **Select Line Button.** The Select Line button changes the function of the control knob from the default Move/Expand action to line selection. The LED in the Select Line button is on when Select Line is active. To scroll through the field line by line, press the Select Line button and rotate the control knob.

Depending on the operational mode, a menu of soft keys may also appear when the Select Line button is pressed. Refer to the relevant sections of the user documentation for a description of the Select Line soft keys and the specific control knob functions. In the diagnostic menus, use the Select Line button to activate a selected choice. For additional information on diagnostic operation, refer to *Diagnostics*, beginning on page 6-55.

Equipment/Signal Sources Required

Most measurements can only be made using either off-air (live) signals or signals from a generator that have the appropriate test signals in the vertical interval. No useful measurement information is displayed if the test signals are not correct for the measurement being made.

Bandwidth

The bandwidth of the measurement set is 0 Hz (DC) to approximately 6.8 MHz (video signals).

Connecting Inputs and Outputs

The measurement set has three video loop-through inputs, one external sync loop-through, two RS-232C DTE ports, a Centronics-compatible printer port, and a VGA output connector on the rear panel (Figure 2-3). The audio options (Option 40 and Option 41) add appropriate connectors for application of the audio signals to the option circuitry. The GPIB Interface (Option 48) add a standard GPIB connector for remote control and GPIB hardcopy output.

You can connect any video signal (of the appropriate format) to any of the three video inputs for normal operation. The serial ports (Port 0 and Port 1) can be used for output to serial printers or for remote control of the measurement set. The printer output port supports Centronics-compatible parallel printers. The VGA output provides support for viewing the measurement set display on a remote VGA monitor. Certain options, such as Camera and Component, require connections to specific inputs for correct operation. Refer to the appropriate option user manual when connecting signals to make those option measurements.

Rear Panel and Connections

The rear panel (shown in Figure 2-10) includes the line voltage and switching module, line voltage selector, fuse holder, a cooling fan, the signal input connectors, the VGA connector, the parallel printer port, and the RS-232 serial ports.

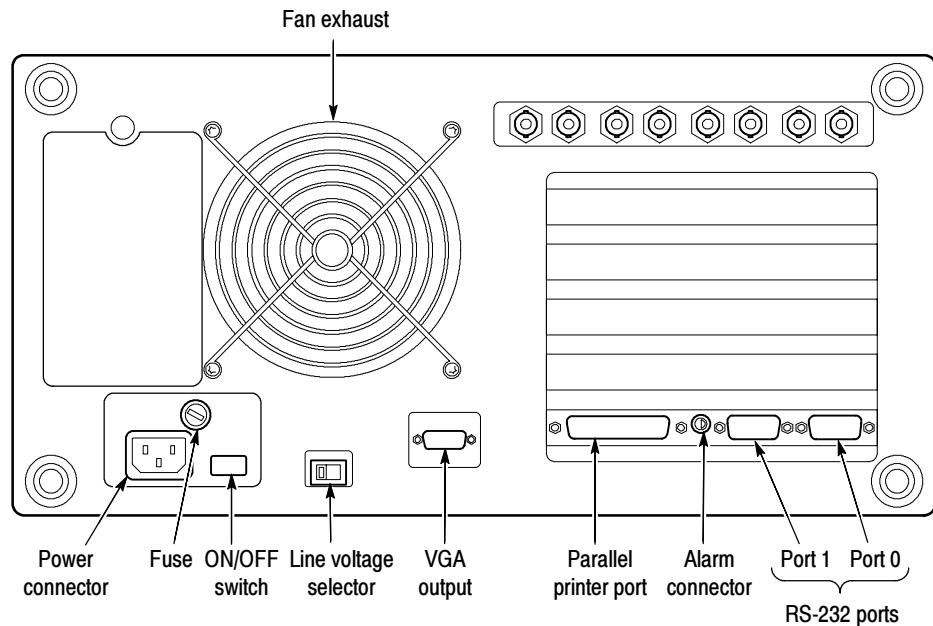

Figure 2- 10: VM700T Video Measurement Set rear panel

The following paragraphs briefly describe each of the rear panel features.

- **Line Voltage and Switching Module.** The module includes the connector and filter for line input voltage, the line fuse, and the main power switch.
- **Line Voltage Selector.** The switch selects either 115 or 230 VAC line input voltage.



CAUTION. *If you intend to operate the measurement set from a line voltage other than the voltage configured at the factory, you must replace the installed fuse with a fuse of the correct rating. See the label on the measurement set rear panel for fuse rating information. Operating the measurement set with the wrong fuse can result in severe damage.*

- **Exhaust Fan.** The fan circulates cooling air to internal components. The fan opening must be free of obstructions for proper ventilation.

- **Signal Inputs.**² These are the connections for Channel A, B, and C signal inputs to the measurement set.
- **External Sync.** This input allows you to connect the measurement set to an external sync source.
- **RS-232 Ports.** These ports are the serial interface from the measurement set to a printer for printing displayed data, screens, and logging information. The RS 232 ports also enables you to access the measurement set remotely using a terminal or a PC. Refer to the *VM700T RS-232 Interface Programmer Manual* for information on configuring the measurement set for remote access and the remote control commands.



CAUTION. *Peripheral equipment operating on ac mains voltages must be properly grounded to prevent applying a floating voltage to the measurement set internal circuitry that can cause damage.*

- **Parallel Printer Port.** You can use this port to connect the measurement set to a Centronics-compatible parallel printer. Uploading firmware upgrades is also done through the printer port. The firmware and uploading program are distributed on disk and uploaded from a personal computer through the parallel printer port. You will need a computer-to-computer data cable (for example and XT compatible LapLink cable) to make the connection for uploading.
- **VGA Output.** You can view the measurement set display on a standard VGA monitor connected to the VGA output connector.

² The signal inputs and the external sync connector are loop-through connections that must be terminated in 75Ω when they are not used. Three 75Ω terminations are provided as standard accessories.

Equipment/Video Signal Sources Required

Most measurements supported by the measurement set are made using television video signals. The video signals can be from either off-the-air broadcast or looped-through programming signals connected to the rear panel Channel and External Sync inputs (see Figure 2-11). Non-loop through signals must have the signal output terminated with precision 75 Ω termination, three of which are provided as standard accessories to the VM700T Video Measurement Set. You must use an appropriate test signal to test the measurements. You can obtain the test signals needed from an appropriate test signal generator. In most cases, the measurement set needs a video signal in a specific format (NTSC or PAL) to make a meaningful measurement.

Waveform mode displays can be of any signal that can be phase locked to the external sync source.

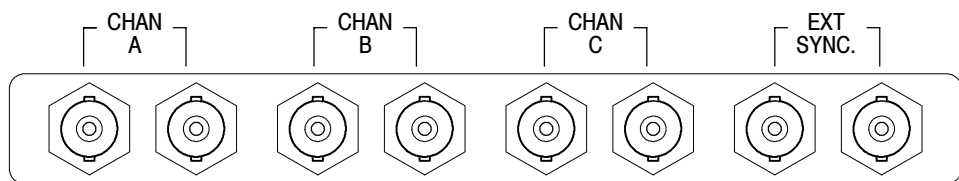

Figure 2- 11: Video signal input connectors

Connecting Audio Option 40 to a Source

The VM700T Audio option comes with two male mini-XLR to female XLR adapter cables wired as shown in Figure 2-12. The mini-XLR ends of these cables connect the Audio option input to an appropriate audio signal source.

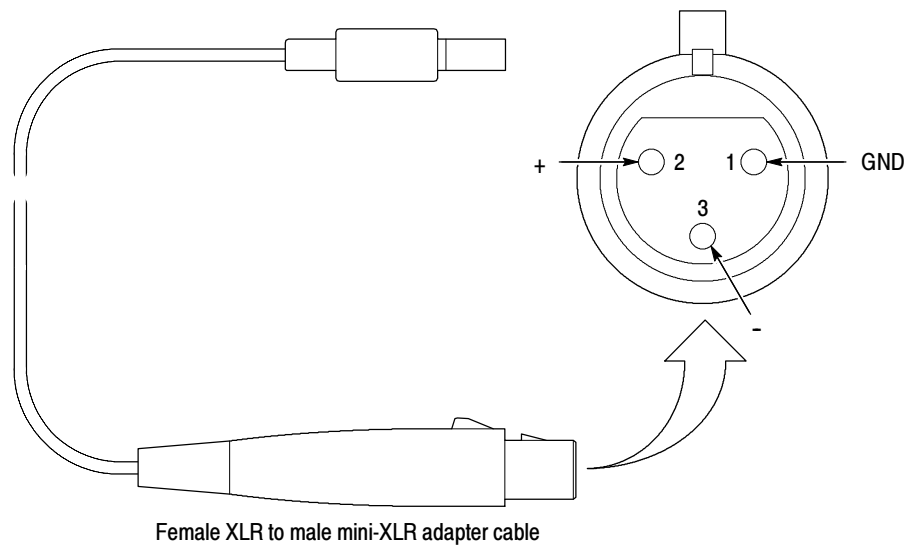

Figure 2-12: Cables and connectors supplied with Audio Option 40

Input Connector Pin Assignments

See Figure 2-13 for the pin assignments for the Option 40 mini-XLR connectors. You access these connectors at the measurement set rear panel.

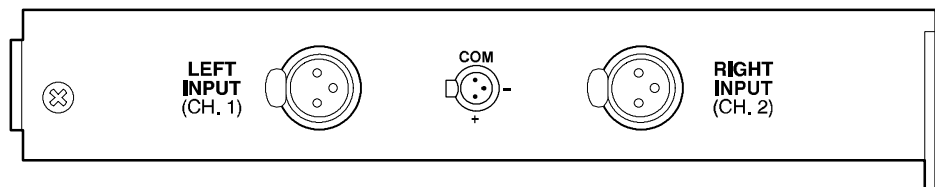

Figure 2-13: Option 40 connectors and pin assignments

Connecting Audio Option 41 to a Source

The measurement set with Option 41 includes a 37-pin connector located on the back panel. Pin assignments for the connector are listed in Table 2-1.

Table 2-1: Audio Option 41 connector pin assignments

Audio Input	+Signal ¹	-Signal	Shield
1 Left	1	2	3
1 Right	21	22	20
2 left	4	5	6
2 Right	24	25	23
3 Left	7	8	9
3 Right	27	28	26

¹ For single-ended input: connect single-ended inputs to a + Signal pin; connect a -Signal pin to shield.

Option 41 Audio Signal Interconnection Cable

Tektronix supplies a DB-37 mating connector kit with Option 41 to assemble the signal interconnection cabling. The connector pin locations are shown in Figure 2-14. Refer to *Option 41 Connector Installation* on page 6-12 for complete installation instructions for the connector.

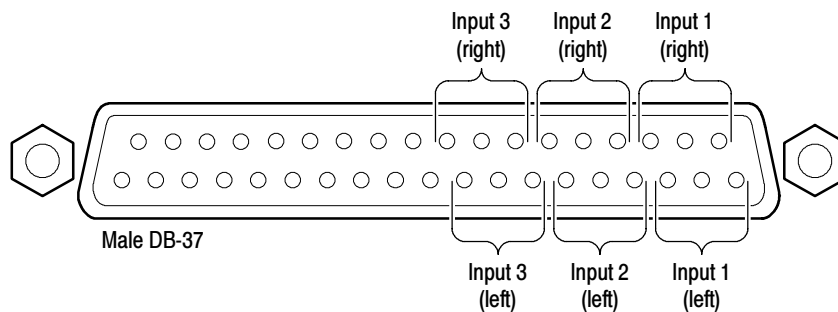

Figure 2-14: Option 41 (Triple-Input Audio) input connector pin locations

GPIB Option 48 Signal Connections and Rear Panel

The Option 48 interface connector is a standard GPIB parallel connection with pin outs adhering to industry standards for location and output signal levels.

GPIB Indicator LED

Seven LED indicators are mounted on the GPIB board. You can see them at the rear of the measurement set as shown in Figure 2-15. Use Table 2-2 to determine what a lighted lamp means and its color.

Table 2-2: Status indicators

Label	Color	Meaning when lighted
LSTN	Green	Addressed to listen (MLA) when on
TALK	Green	Addressed to talk (MTA) when on (The LED is always on in talk-only mode.)
SRQ	Yellow	Service request (SRQ) pending when on
REM	Yellow	Remote control active when on
LOCK	Red	Front Panel lockout
CACT	Green	Controller active state when on
SCTL	Green	System control (never on)

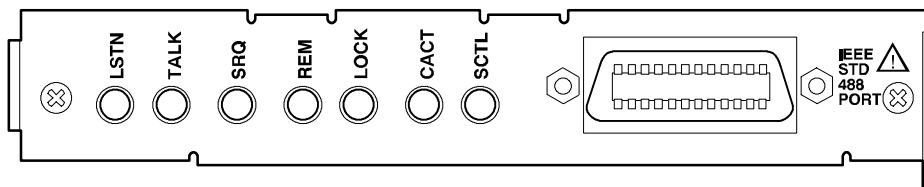

Figure 2-15: GPIB board rear panel

SDI Option 1S Rear Panel Connections

Figure 2-16 shows the VM700T rear panel with Option 1S installed. Figure 2-17 shows a close-up of the Option 1S rear panel.

The Option 1S rear-panel connectors provide the following functions:

- The SDI Ch. A input is a noninterfering loopthrough BNC input for serial digital video signals. You must use the SDI Ch. A input to perform electrical signal measurements in the following applications: SDI Eye Diagram, SDI Jitter, and SDI Wander. The remaining loopthrough connector must be precision terminated in 75Ω when not used in a loopthrough mode. The primary function intended for this input is to measure a signal under test.
- The SDI Ch. B input is an internally precision-terminated (75Ω) BNC input for serial digital video signals. The SDI Ch. B input cannot perform the electrical measurements in the following applications: SDI Eye Diagram, SDI Jitter, and SDI Wander. Although you can use this input to measure a signal under test, the primary function intended for this input is to enable you to use a digital reference signal to make comparative timing measurements with the signal under test on the SDI Ch. A input.
- The Analog Ref input is a loopthrough BNC input for an analog timing reference signal (black burst). The remaining loopthrough connector must be terminated in 75Ω when not used in a loopthrough mode. The only function intended for this input is to enable you to compare your analog timing reference signal with a digital timing reference and/or a signal under test. The timing comparison between an analog reference signal and a serial digital signal will never be a perfect match; however, you will be able to see resolution to within $1 \mu\text{s}$.
- The SDI Output is a buffered BNC monitor output that can be set to output one of the following signal sources: SDI channel A input, SDI channel B input, currently selected SDI input channel (indicated by front-panel LED), or none (no output). You select the signal source in the Source Selection Digital configuration file.

NOTE. You may not be able to use the SDI Output signal effectively as a signal repeater when it is set to output the signal on the SDI channel A input. The output of the SDI channel A signal can be interrupted when you access one of the following applications: SDI Eye Diagram, SDI Jitter, and SDI Wander.

- The AES/EBU Digital Audio input is used to measure external digital-audio signals. This BNC input is internally terminated in 75Ω .
- The LTC Time Code input is a standard Longitudinal Time Code interface input used for time stamping measurement log reports.

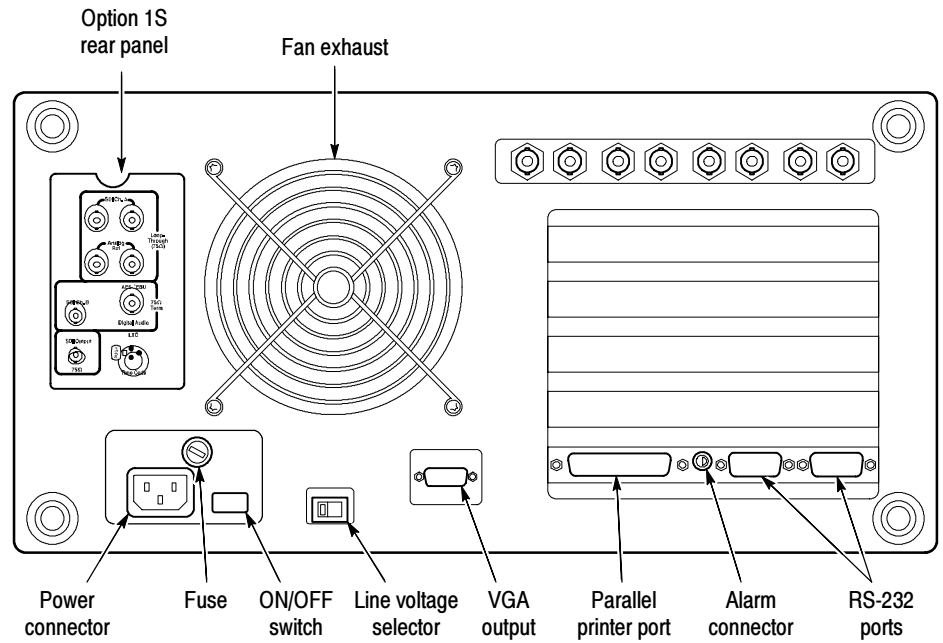

Figure 2-16: VM700T rear panel with Option 1S installed

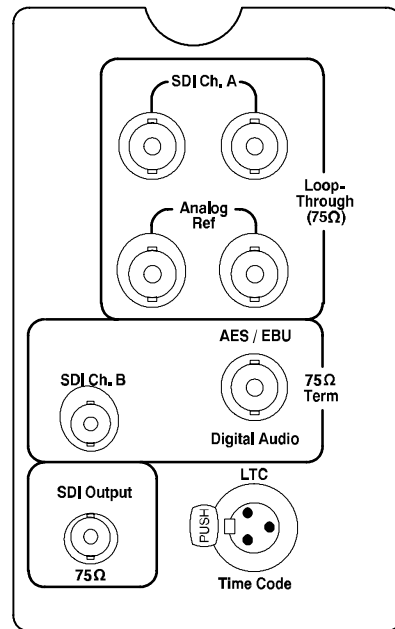

Figure 2-17: Option 1S rear panel

Theory of Operation

This section describes the electrical operation of the VM700T Video Measurement Set using the major circuit blocks as modules.

This section has two main parts:

- *Overview of the VM700T System* describes the system operation of the modules (circuit boards).
- *Module Functional Description* describes circuit operation of the modules from a functional-circuit block perspective. Block diagram illustrations accompany the appropriate text.

Overview of The VM700T System

The video signal enters the VM700T analog input board (A1) through one of three high-impedance loop-through connectors (see the overall block diagram in the diagrams sections of this manual). After it buffers and clamps the input signal and selects a channel, the A1 board passes the signal to the A4 filter switch board where analog filtering (signal conditioning) occurs. After filtering the filter switch board returns the video signal to the A1 board for analog processing (offset, gain, and dither are dynamically applied). The signal then passes to the analog-to-digital (ADC) converter board (A3) where it is digitized.

The A2 genlock board uses an external sync or the sync from one of the three video input channels to create a sampling pulse synchronized (genlocked) to the incoming sync pulses. A 10-bit, analog-to-digital flash converter digitizes the video signal. After digital conversion, the differential ECL data is clocked to the acquisition/controller board (A18).

The data acquisition/controller board (A18) converts the ECL data to single-ended TTL data and stores it in the acquisition memory. The data acquisition memory consists of static RAM accessible by the CPU during data acquisition (the memory appears to be dual ported).

Besides converting ECL data to single-ended TTL, the controller portion of the board controls data acquisition patterns that handle the following analog processing hardware functions: clamping, input selection, sync source, filter selection, offset, gain, dither, and genlock.

The CPU board (A5) contains a microprocessor, a floating-point unit, real-time clock, Flash EPROM, NVRAM, display memory, and display driver hardware. The display driver hardware converts acquired data to video and drives the VM700T display. A monochrome VGA output to the rear panel is also derived from the display driver hardware. The Flash EPROM stores application programs and the NVRAM stores system and configuration files created by the user.

The front panel interface hardware is also on the CPU board. This interface controls the touch-panel, control knob, and keyboard interfaces to the CPU microprocessor.

The audio option boards for Option 40 and 41 provide the interface for audio test signals into the VM700T. Operation of the audio option measurements are discussed in *VM700T Option 40/41/42 Audio Measurements User* manual.

A second option requiring additional hardware is Option 48, the GPIB option. This option provides a interface for remote control in a GPIB controlled system. Operation of the GPIB option is described in the *VM700T GPIB Interface Option 48 Programmer* manual.

Module Functional Description

This part describes the operation of each circuit board module in the VM700T. Block diagrams accompanying the text show the functions of the modules.

Analog Input Board (A1)

The analog input board performs input selection and applies bias, clamping, offset, gain, and dither to the input video before digital conversion. This board also contains a calibration DAC (digital-to-analog converter) that is automatically switched into the signal path to ensure accuracy. A block diagram of the module is shown in Figure 3-1.

Loop-Through Inputs

The three video channels and the external sync signals have independent high-impedance loop-through inputs. The clamped-input amplifiers are high input impedance devices to minimize loading of the loop-through signals.

Mode Control

The mode control block passes or decodes instructions from the acquisition/controller board. These instructions control the clamped amplifiers, sync selection, channel selection, calibration DAC/cal relay operation, and the DVM selection.

Clamped Input Amplifiers

The clamped input amplifiers (there are three, one for each channel) can either DC couple or DC restore (clamp) the video signal. Clamping is applied before channel selection to allow independent clamping of video signals that are synchronous but mis-timed relative to each other. The bias level for each channel is summed with the buffered video just before clamping.

Clamp and Bias Generator

The clamp and bias generator supplies the analog clamp and bias voltages to each clamped input amplifier. Three dual DAC devices are used to provide the six outputs used, a clamp and bias level to the clamped input amplifier in each channel.

The DAC devices receive data and address information from the acquisition/controller board. The 3 address bits select the appropriate DAC (clamp or bias for channels A, B, or C) while the 8 data bits are converted to the actual clamp or bias voltage.

Channel Selection

Output from the clamped amplifiers is fed to a switching matrix that enables the user to select various combinations of input channels.

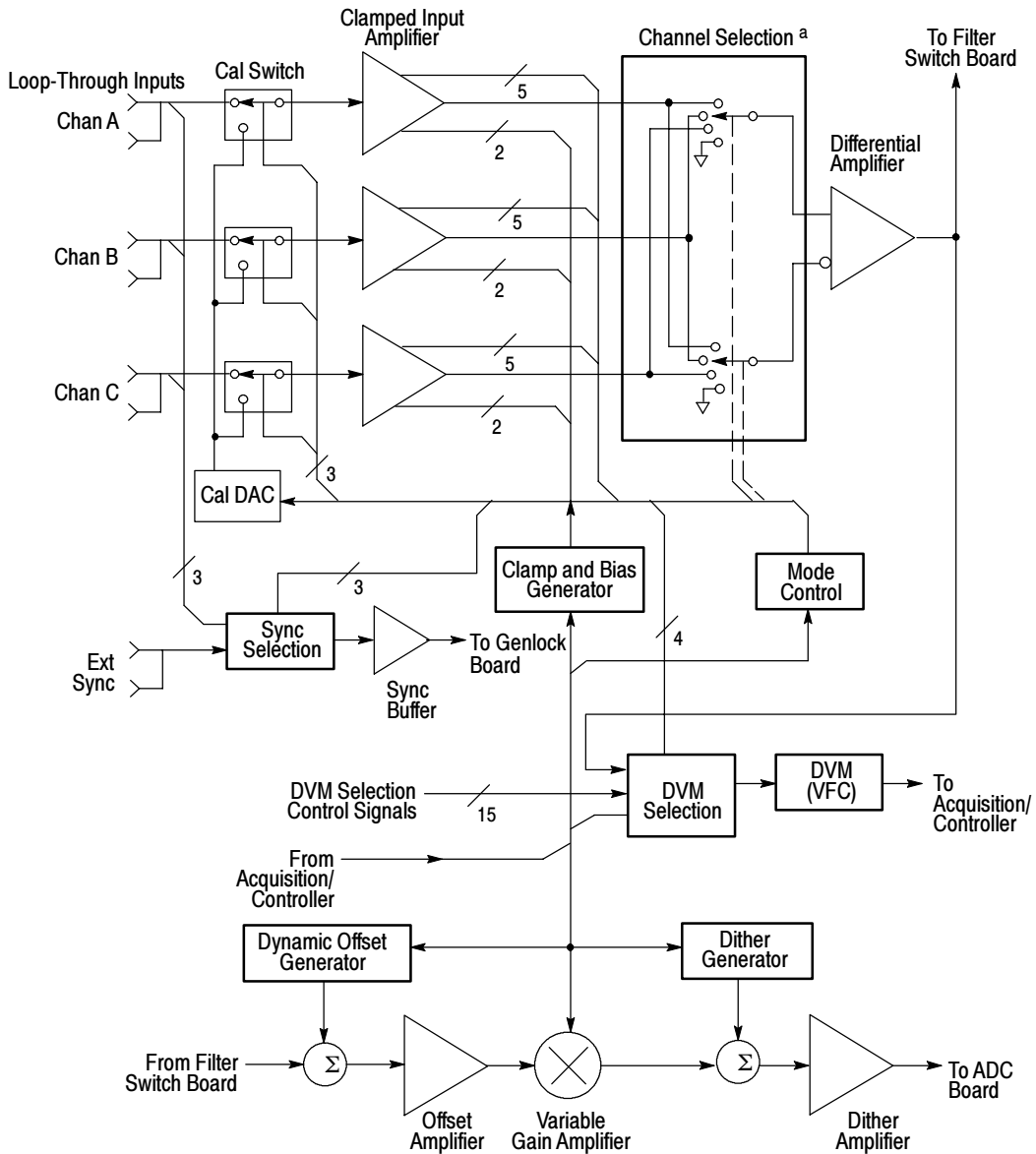

^a Possible front panel selections (using hardware and software):
 A, B, C, A ± B, A ± C, B ± C, B ± A, C ± A, and C ± B.

Possible channel selection combinations in hardware:
 A, B, C, A ± B, A ± C, B ± C, ± A, ± B.

Figure 3- 1: Analog input board (A1) block diagram

Differential Amplifier The differential amplifier combines the differential output of the switching matrix and produces a single-ended video output signal which is connected by coaxial cable to the filter switch board. After being filtered (if filtering is needed) the video signal returns to the analog input board for offset, gain, and dither processing.

An acquisition description supplied by application software causes the acquisition/controller board to dynamically apply dynamic offset, programmable variable gain, and dither to the input video.

Dynamic Offset Generator and Offset Amplifier Data bits from the acquisition/controller board drive the dynamic offset generator DAC and provide a dynamic offset range of -1.28 to $+1.27$ volts in 10-mV steps. This offset is summed with the video signal to keep the signal centered in the dynamic range of the analog-to-digital converter (ADC). The video signal with offset applied is buffered by the offset amplifier and passed to the variable gain amplifier.

Variable-Gain Amplifier The variable gain amplifier consists of a resistive divider range switch followed by an amplifier with continuously variable, voltage-controlled gain. The control voltage comes from a 12-bit DAC whose input code comes from a look-up table contained in a programmable logic device. Outputs from the look-up table also control the range switch. The input to the look-up table is the five bit gain control word from the acquisition/controller board. Together, these components provide a gain range of 0 to 7.75 in steps of 0.25.

Dither Generator and Dither Amplifier Dither data bits from the acquisition/controller board can be converted to 64 analog levels (usually, only the first 32 levels are used) to effectively increase the resolution of the 10-bit ADC. The dither amplifier buffers the processed video signal before passing it to the ADC board where it is digitized.

Calibration DAC The calibration DAC is a precision digital-to-analog converter used for gain compensation over the analog signal path (including the analog-to-digital converter). A calibration switch on each input channel couples the calibration signal onto the signal path at regular intervals. The output of the ADC provides calibration information that is stored in a look-up table. The VM700T uses the look-up table information to maintain its luminance accuracy specification without the need for periodic readjustments.

Sync Selection

The VM700T gets sync from one of two sources:

- directly from the channel A, B, or C loop-through inputs
- from the external sync loop-through input

To maintain a high impedance level for the video loop-through inputs, the sync selection buffers the selected signal. Following the sync selection is an amplifier that returns the video to the nominal one-volt level required by the sync stripper circuitry on the genlock board.

The sync stripper needs a negative-going sync pulse. To enable the instrument to lock to inverted video, the amplifier following the sync selection can be programmed to invert the (inverted) video selected as the sync source (push down the front panel SOURCE A/B/C button for about one second to invert the video).

NOTE. *Video appears on the display in whatever orientation (inverted or non-inverted) it appears at the input connector. When you push the SOURCE A/B/C button only the video used as the sync source is inverted.*

DVM Selection and DVM

The DVM measures the average picture level (APL). The VM700T measures the analog average as the video exits to the filter switch board. This analog voltage is converted to a frequency output and sent to the acquisition/controller board where it is averaged by a counter. The counter output is read by applications that furnish the APL readout on the display.

Fifteen other inputs to the DVM selection block are selected by two multiplexers. The following selections are included:

- Outputs of the clamped amplifiers
- Offset amplifier
- Dither amplifier
- Calibration DAC
- Video from the filter switch board
- Analog ground
- Clamp levels for channels A, B, and C
- TEMPSENSE from a thermistor
- +REF output from the precision voltage reference

The Genlock Board (A2)

The genlock board sends a constant frequency sampling strobe to the analog-to-digital converter (ADC) board. The NTSC and PAL television standards are supported by both the genlock board and application firmware. A block diagram of the genlock board is shown in Figure 3-2.

The sampling strobe may be generated by one of the following three methods, or modes:

The strobe may be phase locked to the incoming video signal (synchronous sampling mode), to force 910 (NTSC) or 1135 (PAL) samples per line.

The strobe may be phase locked to an internal crystal oscillator running at 20.25 MHz (asynchronous sampling mode). This method of generating the sampling strobe avoids errors that could be caused by unstable signals typically found in video cassette recorders (VCR).

When timing measurement precision is most important or when greater timing resolution is desired, the strobe may be exactly 20.25 MHz (20.25 MHz sampling mode). This mode of operation eliminates the small timing errors inherent in phase-locked loop systems.

In addition, the genlock board sends line and frame sync strobes to the ADC board.

Sync Stripper

The sync stripper removes all luminance and chrominance information from the baseband composite video signal, but leaves the horizontal and vertical sync information. The sync stripper provides this information on its horizontal sync and composite sync (combined horizontal and vertical sync) outputs.

Video signals from VCRs sometimes contain only rudimentary vertical sync information, which can cause the sync stripper to mis-trigger. A 200 microsecond delay allows the sync stripper to function properly in the presence of this kind of vertical sync.

Some countries place digital audio on the horizontal sync pulse using sound in sync (SIS). A menu selection in the waveform application engages circuitry in the sync stripper to sustain good performance in the presence of SIS.

Crystal Oscillator

A temperature-compensated crystal oscillator provides a 20.25 MHz clock with 5 parts per million (ppm) accuracy. It is divided to either an NTSC or PAL line-rate frequency and used as one of the selections for the phase-locked loop reference clock. It is also used as the sampling strobe in 20.25 MHz sampling mode.

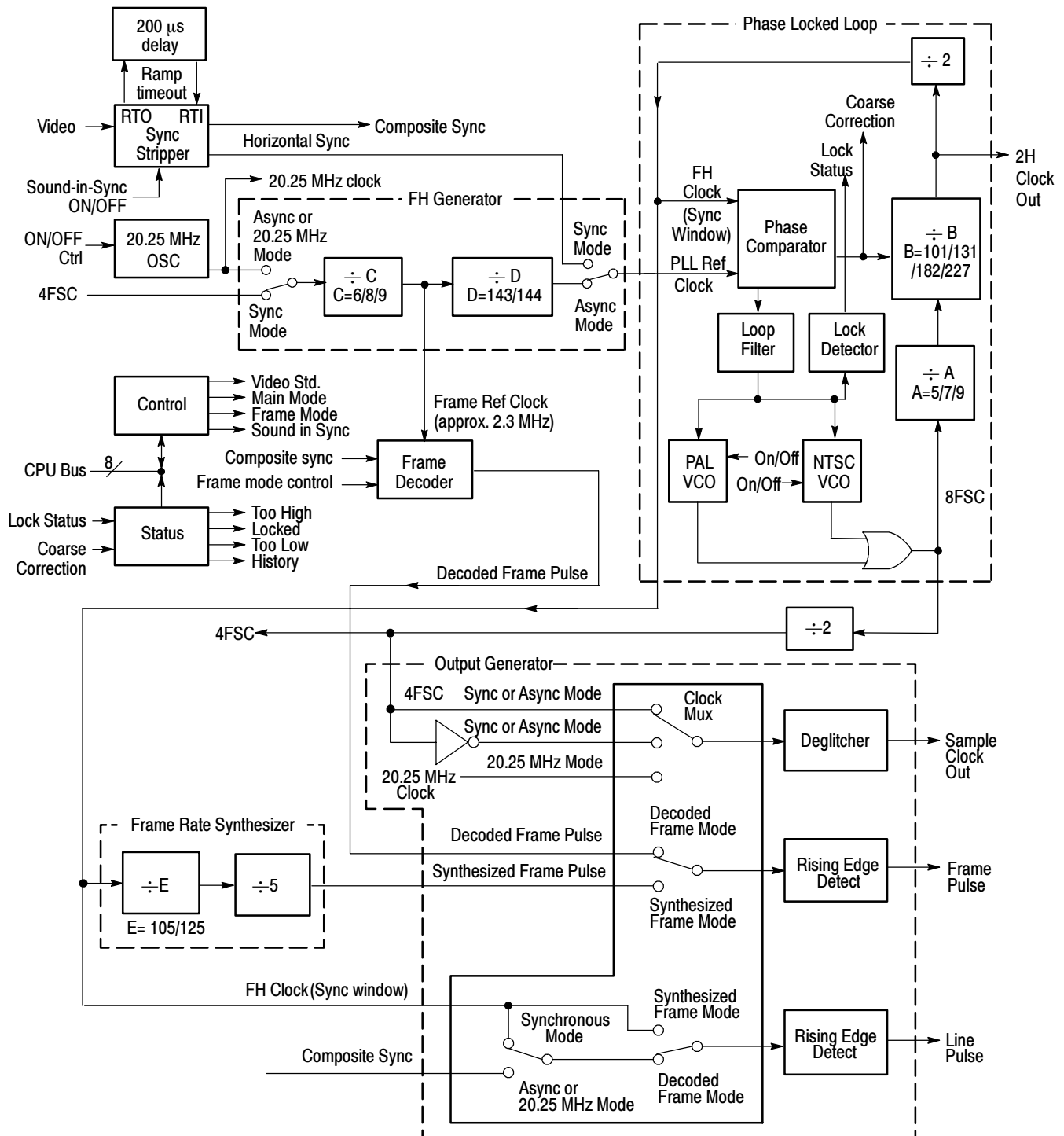

Figure 3-2: Genlock board (A2) block diagram

FH Generator	The FH generator provides an NTSC or PAL line-rate frequency reference clock to the phase-locked loop, using either the horizontal sync output from the sync stripper or the line-rate frequency derived from the 20.25 MHz crystal clock. The FH generator also provides a timing reference to the frame decoder.
Phase-Locked Loop (PLL)	<p>The PLL takes in a reference clock at the PAL or NTSC line-rate frequency and outputs a frequency of 8 times the color subcarrier frequency (8Fsc). The PLL is not used in 20.25 MHz sampling mode.</p> <p>The phase comparator compares the reference clock to the output of the PLL feedback circuit and generates a correction voltage to keep the two synchronized. The feedback circuit outputs a window centered on the leading edge of the reference clock. If the reference clock falls outside the window, the PLL is unlocked, and the coarse correction circuitry activates to quickly bring the reference clock back into the window. The loop filter smooths and integrates the correction voltage, which is then used to drive the voltage-controlled oscillators (VCO).</p> <p>Two VCO generate the 8Fsc clock, one for PAL and the other for NTSC. Control logic enables one VCO at a time. The output of the selected VCO is divided to the line-rate frequency and fed back to the phase comparator.</p>
Divide-by-2 Frequency Divider	A divide-by-2 counter divides the 8Fsc VCO output frequency to four times the color sub-carrier frequency (4Fsc) and ensures a 50% duty cycle output.
Frame Decoder	The frame decoder examines the composite sync signal from the sync stripper to determine the location of vertical sync. The odd field detection modes output a pulse on each odd-numbered field. The all field detection mode outputs a pulse on every field and uses an algorithm that can detect rudimentary vertical sync information produced by VCRs.
Frame Rate Synthesizer	The frame rate synthesizer generates a frame-rate frequency output that is used in the synthesized frame mode. The frame rate synthesizer does not operate in 20.25 MHz sampling mode.
Stripped Sync Processing	The stripped sync logic (not shown in the block diagram) removes noise from the sync stripper's composite sync output. In sound-in-sync (SIS) mode, the SIS pulses are removed by combining composite sync with the sync stripper's horizontal sync output. Impulse noise (such as VCR head switches) is removed by gating composite sync with a 2 microsecond window pulse, centered on the leading edge of sync.

Output Generator

The output generator provides sampling, line, and frame strobes, to the analog-to-digital converter (ADC) board.

Sampling strobe output: A multiplexer selects either the four-times subcarrier (4Fsc) clock from the phase-locked loop or the 20.25 MHz crystal clock. A transparent latch stops the clock output when changing sources, ensuring a smooth transition between them.

Line strobe output: A multiplexer selects either composite sync or the window pulse from the phase-locked loop and converts it into a pulse one sample clock period in duration.

Frame strobe output: A multiplexer selects either the decoded frame pulse from the frame decoder or the synthesized frame pulse and converts it into a pulse one sample clock period in duration.

Control

An 8-bit read/write register is used for mode control. Control bits select the video standard, sampling mode, frame mode, and sound-in-sync (SIS) mode. Logic provides enables for various hardware functions, with LEDs on the circuit board to indicate which of them are in use.

Status

An 8-bit read-only register is used to read genlock status. Some of the bits indicate the current lock status and history. The remaining bits indicate VCO on/off status and the genlock hardware revision level. LEDs on the circuit board indicate the current lock status and whether any unlocks have occurred since the last read of the status register.

The Analog-to-Digital (ADC) Board (A3)

+2.5 V and -2.5 V Regulators

The +2.5 V and -2.5 V regulators provide a balanced low-noise power source for the A/D converter. The +2.5 V source is the output of a 5 V, 3-terminal regulator stacked on the -2.5 V supply. The -2.5 V supply has a feedback circuit from the A/D converter VREF output. The feedback circuit adjust the -2.5 V output over a ± 0.5 V range to hold the VREF output at ground reference.

Signal Conditioning Amplifier

The signal-conditioning amplifier is a buffer between the anti-aliasing filter and the A/D Converter. The operational amplifier has 75 Ω input impedance, adjustable gain, and adjustable response. It has low distortion with 150 Ω output loading and operates between the +5 V and -5.2 V supplies. Its low impedance output directly drives the A/D Converter. An RC compensation network corrects for the small rolloff of the anti-aliasing filter at 5 MHz.

The amplifier includes a limiter that restricts the output voltage to be between +1 V and -1 V to protect the A/D converter input from excessive signal levels or power-up transients.

A/D Converter

The A/D converter is a 12-bit monolithic converter that operates from 14 megasamples per sec to 20.25 megasamples per second. It has a dynamic voltage input range of ± 0.5 V centered around its VREF output. The VREF output is held at ground reference by the feedback to the -2.5 V power source so the input voltage range is centered around ground. The architecture of the A/D converter delays the output by 3 clock cycles.

The differential clock input of the converter is driven by an ECL source that is capacitively coupled to the clock input. The TTL level outputs of the A/D converter are divided down to ECL levels through a resistive divider network and applied to buffers. A -1.3 V reference for the ECL buffer amplifiers is derived from the A/D converter's balanced power supply.

Buffer

The buffer is composed of 12 ECL buffers, one for each output line from the A/D converter. They are located close to the A/D Converter to minimize loading on the converter outputs and unclocked to minimize delays.

Output Latch

The output latch supplies differential drive for the cable transporting the data to the acquisition/controller. The latch is set and reset by ASYNC_SET and ASYNC_RESET from the acquisition/controller board. It is clocked by the OUT_LATCH clock derived from the 4FSC signal.

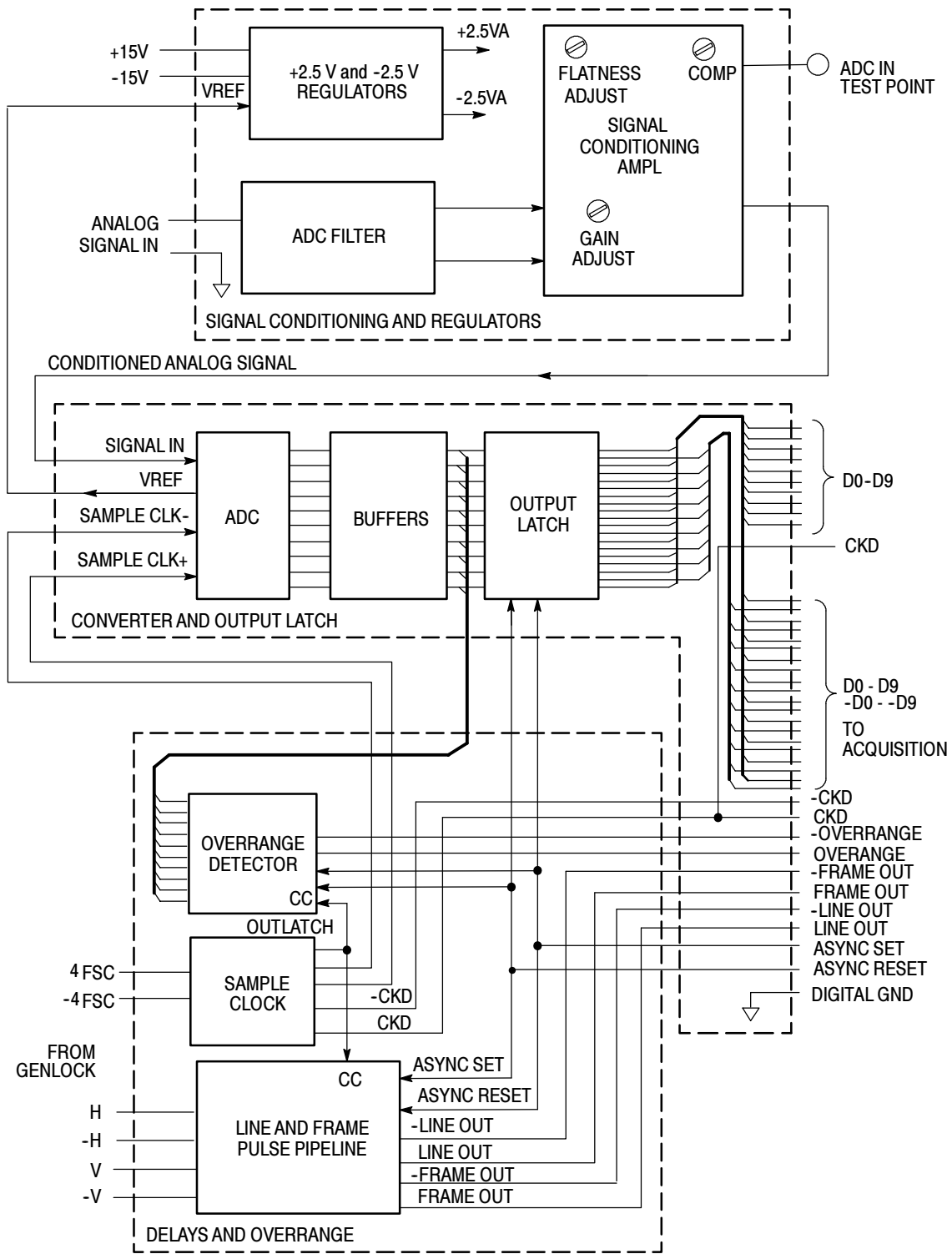

Figure 3-3: ADC board block diagram

- Line and Frame Pulse Pipeline** H-sync and V-sync from the GenLock board are applied to the Line and Frame Pulse Pipeline. The pipeline is a series of flip-flops that delays the frame and line sync by the same amount as the A/D converter delays the video.
- Overrange Detector** The Overrange detector checks to see if the eight most-significant bits of the 10-bit samples are either all 1's or all 0's. If either event occurs, Overrange is asserted for that sample.
- Sample Clock** The 4FSC (four times the subcarrier frequency) signal from the GenLock board is used to develop the sample clocks (SAMPLE CLK and -SAMPLE CLK) to the ADC and the acquisition clocks (CKD and -CKD) for the acquisition/controller board. The clocks to the acquisition system are connected through a 36-pin ribbon cable along with 10-bit data from the A/D converter and the Frame Out and Line Out signals.

Filter Switch Board (A4)

The filter switch board performs analog filtering of the video signal. Filtering is performed by one of five filters mounted as daughter boards on the main circuit board. The video signal is intercepted on the analog input board just after channel selection and then returned for analog processing (offset, gain, and dither). Figure 3-4 shows the filter switch board block diagram.

The filters are NTSC band width limit, Chroma bandpass, IEEE low pass, differentiated step, and low-frequency noise.

Filter Select and Control

The acquisition/controller board provides inputs to the filter select and control block. After decoding, these inputs select and control the desired filter. Note that only the low-frequency noise filter has controllable characteristics. This block also requests a six-bit filter ID from the filter in each slot and transmits it to the acquisition/controller board.

The filter select and control block provides three types of outputs:

- Filter selection
- Filter poll, a request for filter I.D
- Filter control (used only by the low-frequency noise filter)

Slot 0

Slot 0 is the straight-through path of the filter switch board; it has no connectors for mounting a filter. In place of a filter, a resistor network provides a small amount of signal attenuation. The loss of each filter (in slots 1-5) is adjusted to match the loss from the resistance in slot 0.

Slots 1-5

Slots 1-5 accommodate the five plug-in filters.

The only filter with controllable parameters is the low-frequency noise filter. The -3 dB point on this filter can be set to 1 kHz, 7.5 kHz, 10 kHz, or 15 kHz.

Output Amplifier

The output amplifier provides the 75 Ω drive needed for the input to the analog input board. When the acquisition/controller board asserts FIL3 the output amplifier switches from unity gain to a gain of eight.

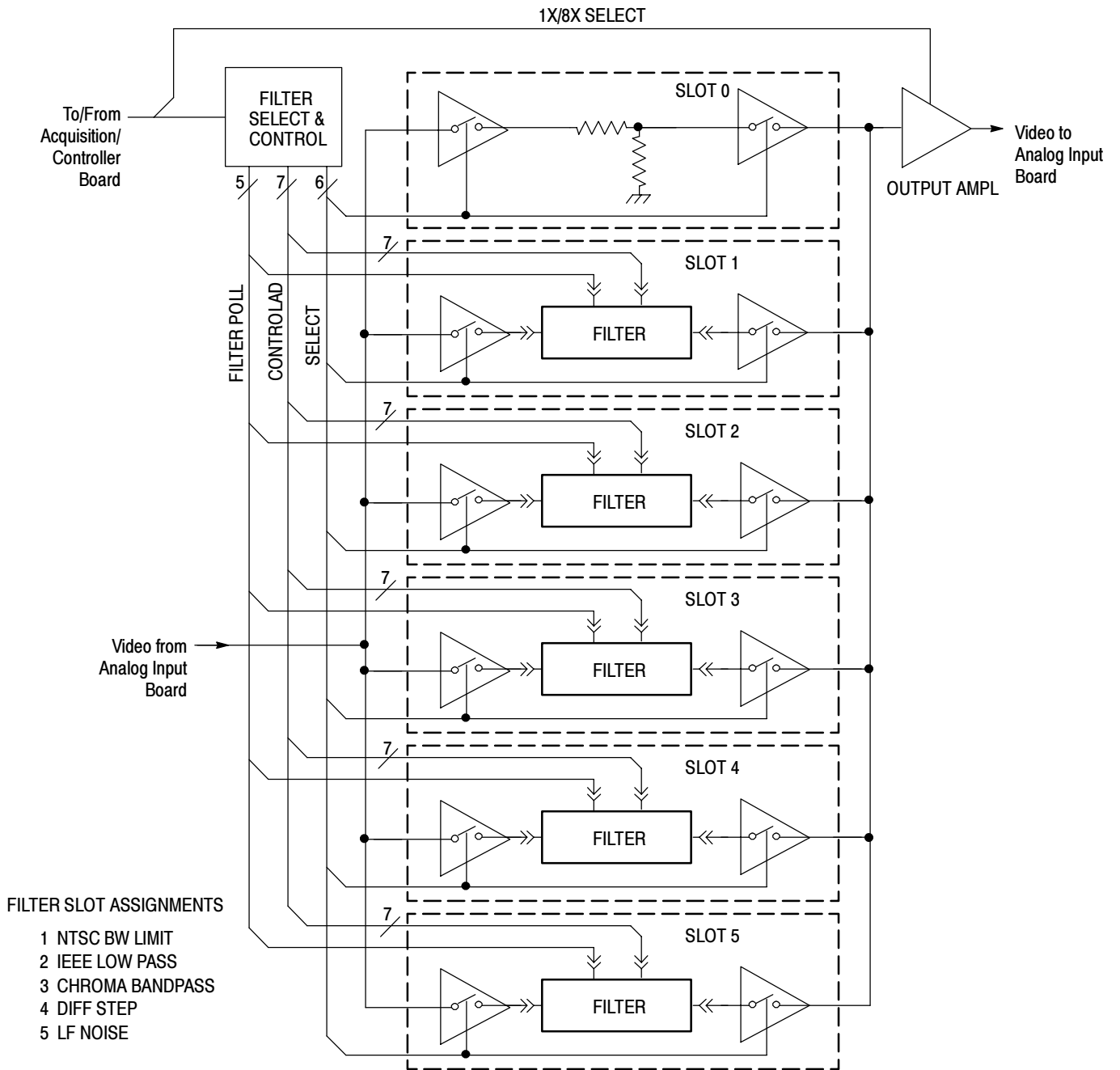

Figure 3-4: Filter switch board (A4) block diagram

CPU Board (A5)

The CPU and CPU I/O boards are the complete central processing core for the VM700T. The CPU board incorporates Flash EPROM program memory, nonvolatile memory for data and user-programmed routines, the front panel interface, and the display driver hardware. The CPU I/O board provides the interface between two RS232 serial ports, one parallel printer port, and the central processor.

The CPU board microprocessor runs at 40 MHz. A floating point unit (FPU) processes floating-point instructions. The microprocessor and the FPU sit on a CPU bus that includes the 32 data lines, 32 address lines, and control lines from the microprocessor. All other buses on the CPU board are 8 bits wide.

Figure 3-5 is a simplified block diagram of the CPU board showing the major functional blocks of the circuit board.

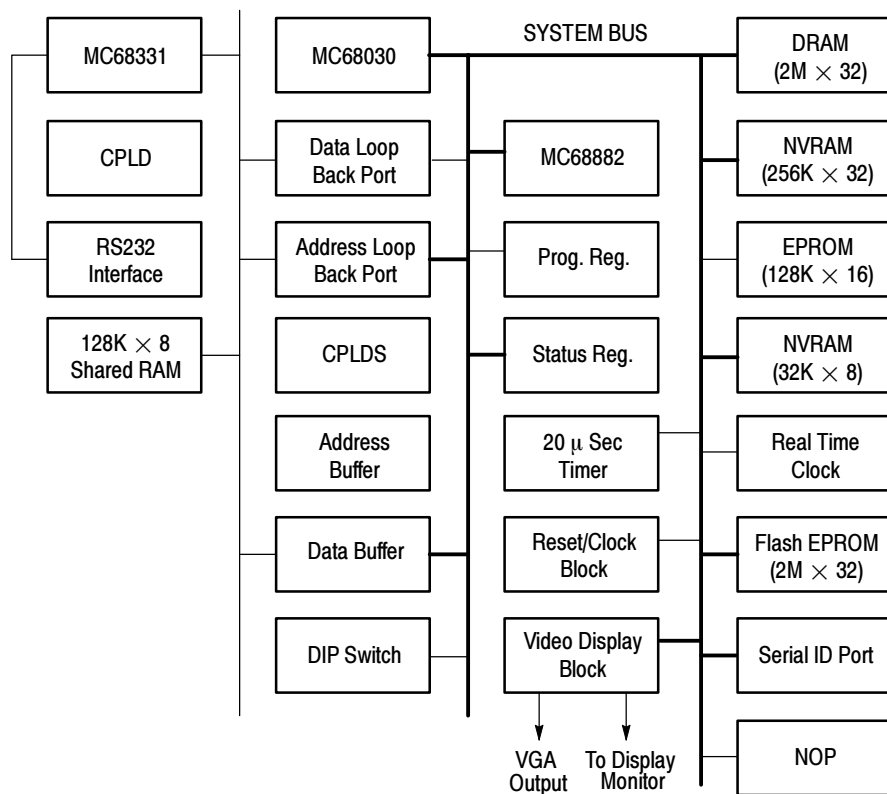

Figure 3-5: CPU board block diagram

System Bus

A buffer connects all 32 data and address lines and the appropriate control lines from the CPU bus to the system bus.

EPROM	<p>The EPROM is a 16-bit wide device with a maximum allowed memory of 512 Kbytes. This is a read-only memory where the system boot-up code resides.</p> <p>Under normal operation (after the boot sequence is complete) the CPU executes instructions contained in Flash ROM (programmable read-only memory).</p>
NVRAM	<p>A 128k x 8 volatile static RAM module with battery-backup is used as the nonvolatile, random-access memory device. User programmed routines, front-panel setups, and measurement results are stored in the NVRAM. The memory interface allows byte access only. The memory defaults to read only at power on or after a system reset.</p>
NVRAM SIMM	<p>The NVRAM consists of two banks of 512 kilobytes SIMM of 32-bits width. It is a low power static memory. The memory interface allows byte, word, and long word access. The memory defaults to read only at power up or after a system reset. The memory interface supports 1, 2, and 4 MB SIMM parts.</p>
Flash EPROM	<p>The program memory is stored in Flash EPROM. Programming of the Flash EPROM is possible through the parallel printer port for system upgrades. Byte, word, 3-bytes, and long word access are allowed in read mode. Writes are restricted to long word access during device programming. The memory defaults to read only at power up or after a system reset.</p>
DRAM	<p>This is the microprocessor's working memory space. Memory sizes of 4, 8, or 16 Megabytes in SIMM boards are supported. A dynamic RAM controller provides the interface between the dynamic RAM and the CPU microprocessor.</p>
Real-Time Clock	<p>A single time-keeper device provides a real-time clock, alarm, watchdog timer, and interval timer.</p>
Display ASIC and VRAM	<p>A display ASIC (application specific integrated circuit) processes the display information and prepares it for display. The video RAM is divided into eight bit planes (display memory layers). Data to be displayed is loaded in the video RAM. Data is then read out of the VRAM as required for the display updates. Refresh information is written into alternate bit planes as the display data is being read from the active bit plane. A VGA output from the display system permits viewing the display on an external VGA monitor. The VGA connector is located on the back panel of the VM700T</p>

Front Panel Processor

A 32-bit microcontroller is used for the front-panel processor. A built-in clock synthesizer generates the required system clock frequency for the front-panel processor and the external interface circuitry. The front panel is scanned for button presses, knob rotation, and touch screen touches. These inputs are recorded and processed to provide the user-control interface to the CPU.

CPU I/O Board (A20)

A simplified block diagram of the CPU I/O board is shown in Figure 3-6. This board handles the data flow between the CPU and the two serial RS232C ports and one parallel printer port. The parallel printer ports has a dual purpose; besides being the printer output port, it acts as an input port when used to upload new firmware to the Flash EPROM.

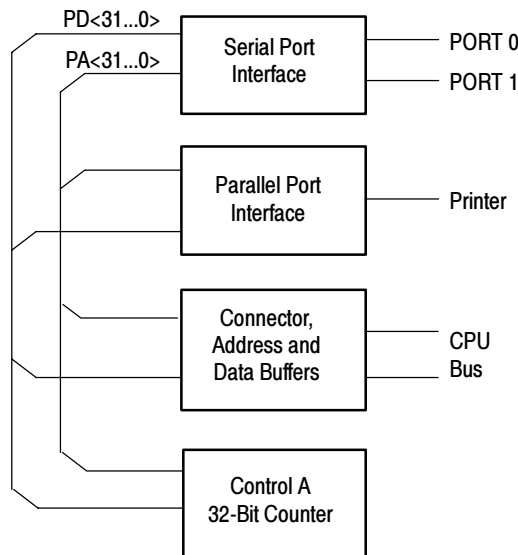

Figure 3- 6: CPU I/O board block diagram

Serial Ports

There are two DB9 RS-232 serial communication ports. Of the nine pins in the connector, pins 6 and 9 are not connected. The remaining pins are in the standard configuration for a DB9 RS-232 DTE serial connector as shown in Table 3-1.

Table 3-1: Signals used by VM700T RS-232C ports

Pin	Signal	Notes
1	DCD (Data Carrier Detect)	Required for modem connections only. This signal typically comes from a modem and indicates that a phone connection is made.
2	RD (Receive Data)	The VM700T receives data on this pin.
3	TD (Transmit Data)	The VM700T transmits data on this pin.
4	DTR (Data Terminal Ready)	Required for modem connections only. This pin is always high when the VM700T is turned on. When DTR is asserted, the modem knows it is connected to a "live" PC/terminal.
5	SG (Signal Ground)	
6	DSR (Data Set Ready)	Unused in the VM700T.
7	RTS (Request to Send data to the VM700T)	With hardware flow control (CTS/RTS selected), normally RTS connects to the CTS line of a terminal, and the line is active when the VM700T is ready to receive data. When the receive buffers of the VM700T are nearing capacity, RTS goes inactive, indicating to the sending device to stop transmitting data. With software flow control set to XON/XOFF or with None selected, RTS is always active.
8	CTS (Clear to Send)	With Flow Control (CTS/RTS selected), the VM700T is enabled to transmit data by a high level on pin 8, and is disabled by a low level. It is normally connected to the RTS line of a terminal. With Flow Control (None or XON/XOFF selected), the VM700T transmits data regardless of the CTS level.
9	RI	Unused in the VM700T.

Parallel Port Interface

A multipurpose I/O controller provides the interface between the parallel port and the CPU. Only the parallel port controller is used for this application.

32-Bit Counter

The clock frequency of this counter defaults to 1.8432 MHz. The clock frequency is controlled by bits from a status register. It may be disabled, set to the default frequency, or set to either 921 kHz or 460.8 kHz.

Connector

The connector circuitry provides a 32-bit address bus buffer and a 32-bit data bus buffer. Addresses are unidirectional. The data buffer is bidirectional to handle data both to and from the CPU I/O board. These busses are connected to the system bus for interconnection to the CPU.

Data Acquisition/Controller Board (A18)

The combined Data Acquisition/Controller board (A18) does both data acquisitions and controlling of the acquisition process. The acquisition portion of the board is a programmable data interface between the ADC board and the CPU microprocessor. The controller state machine can be programmed to recognize data sequences and generate signals to the data acquisition section, telling it when to perform various tasks. Figure 3-7 shows a block diagram of the data acquisition section of the Acquisition/Controller board.

Video Data and Clock Inputs	Data from the ADC board enters the Acquisition/Controller board through a 34-pin connector. The inputs are differential ECL-levels terminated by 100 Ω resistors. ASYNC-SET and SYNC-RESET are outputs controlling the ADC board.
FIFO/Demultiplexor	The FIFO (first in/first out) consists of register files and a controlling device. The controller makes the synchronous register files behave as a FIFO file.
Acquisition Control	This block is the control and timing center of the Acquisition system. It handles static RAM access arbitration, CPU dual-porting, state-machine instruction interpretation, CPU handshaking, the real-time control, FIFO control, Min-Max control, static RAM control and address sequencing for these RAM.
Acquisition Clock	The acquisition control clock circuit crystal oscillator running at 20.000 MHz. Various delayed versions of it are derived by a delay line. The clocks are used in the acquisition ASIC for accurate timing of the control activities. One clock output is fed to the controller section.
Data Bus Interface	Because the Acquisition/Controller board has its own 20 MHz clock (it is independent of the CPU microprocessor) the CPU microprocessor interface is asynchronous into the acquisition section of the board. The data bus interface controls connection between the CPU data bus and the acquisition data bus to allow static RAM accesses.
Data Acquisition Memory (Static RAM)	The acquisition memory consist of sixteen, 64 K x 4 bit fast (25 ns or lower access times) static type RAM in two rows of eight devices, with 17 total address bits and 32-bit-wide data bus.
Min-Max ASIC	The min-max ASIC keeps a running record of the minimum and maximum video data read from the FIFO, as well as latching whether a line or frame pulse or an over-flow or under-flow has occurred. Reading the Min-Max results resets the circuit to begin a new accumulation.

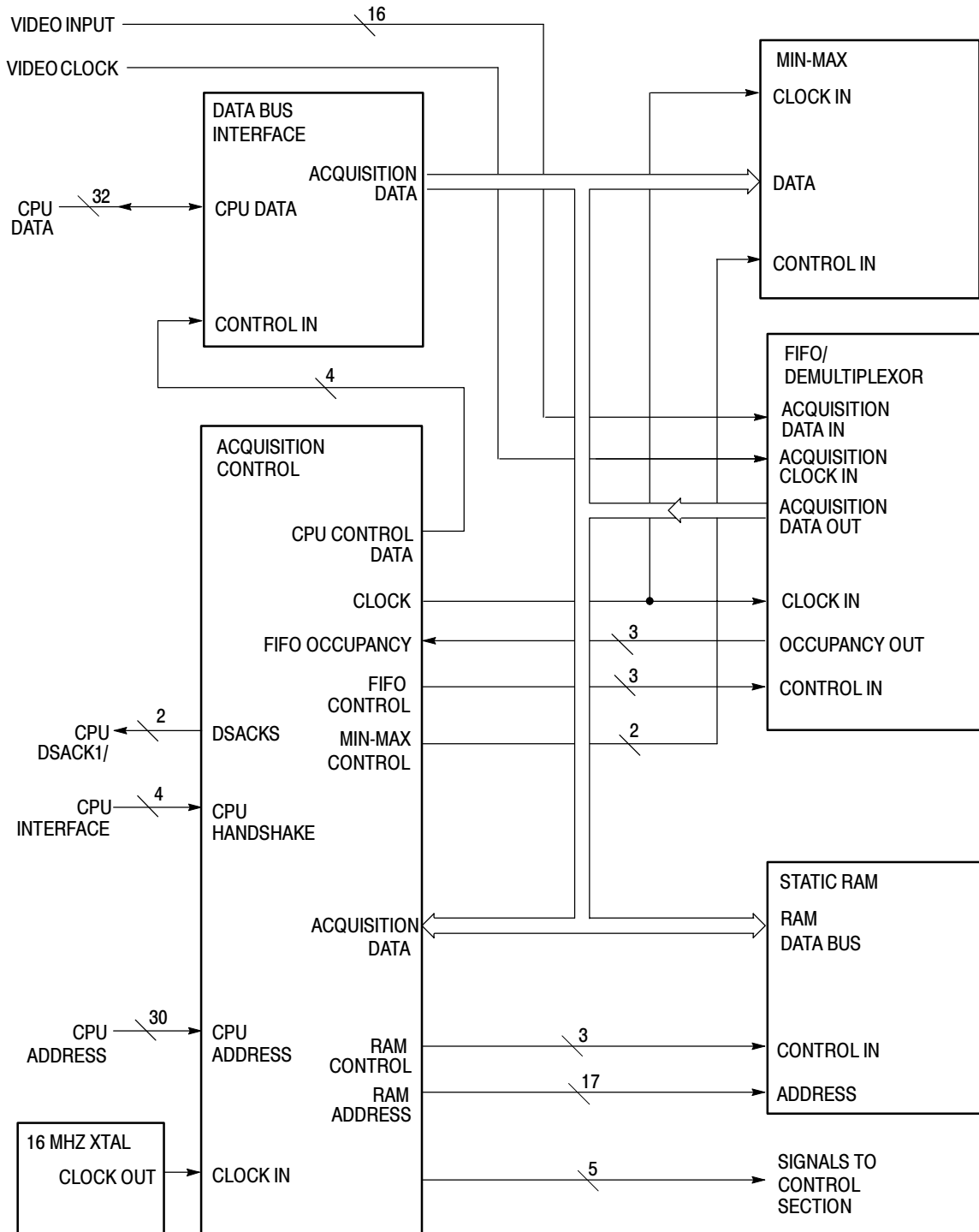

Figure 3-7: Acquisition circuitry block diagram

- Controller Section** The controller portion of the board performs the following functions:
- controls the VM700T analog front end
 - receives and processes digitized data from the ADC board and passes it to acquisition memory
 - controls acquisition patterns

Figure 3-8 shows a block diagram for the controller circuitry.

- Bus Buffers** All 32 data lines and the required control and address lines from the system bus are buffered on this board. Many of the data and address lines are buffered on the board a second time before being used to drive multiple devices.

- Controller ASIC** The majority of the control logic and high speed logic functions are incorporated into the controller ASIC (application specific integrated circuit). The controller now has new functionality for DVM and clamp gating. The controller handles CPU interfacing, DVM and clamp counter gating control, bus routing control, DVM counting, and some of the buffers that handle data flow.

- Address Decoding** Address decoding is handled by the same decoder as for the Acquisition section of the board.

- Output Latches and Analog Input Board Interface** This block controls the dynamic gains, offsets, input selections, and dither. The dither counter is implemented in a PAL and octal D flip-flop. The output signals from this block are fed directly to the Analog boards in the top compartment of the instrument. They perform the following actions:

- enables the controller board DVM block
- loads four control registers within the mode control and DVM selection blocks
- latches 12 (as 8 + 4) bits of data into the calibration DAC (located on the analog input board)
- loads 8 bits of data into each register of the bias and clamp level octal DAC (located on the analog input board)

- Clamp Counters** There are stored patterns, selected by the four bits from the control register, are stored. The selected pattern provides gating for input signal clamping and the DVM. The gating information drives a triple timer/counter, U6. The ATRIG, BTRIG, and CTRIG outputs from the triple-timer/counter drive a one-shot multivibrator on the analog input board. Trigger pulses are generated for each line where clamping is to be applied. These pulses determine the point on a line where clamping begins; other control lines on this board control circuitry on the analog input board that sets the clamp level and duration.

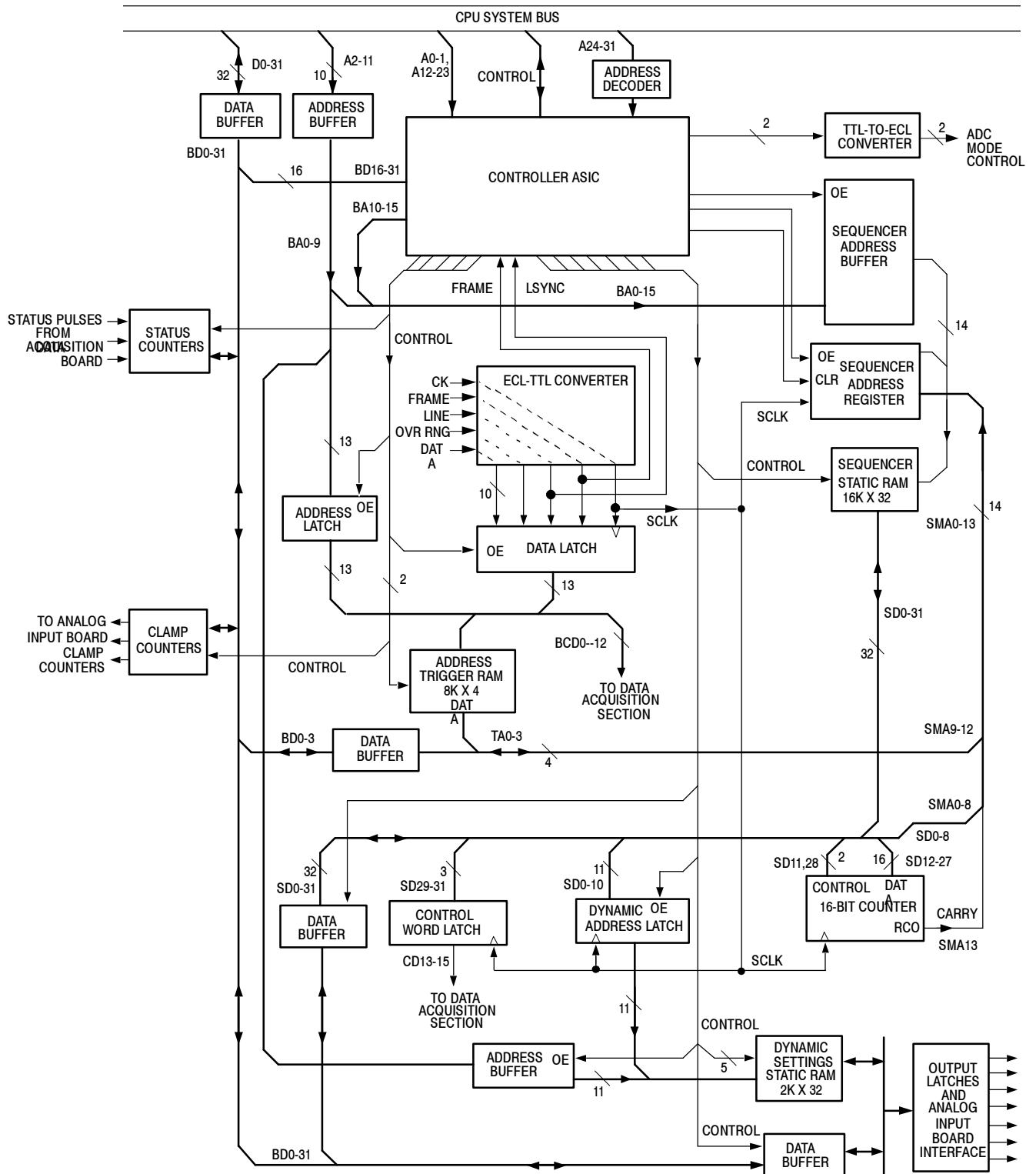

Figure 3-8: Controller section block diagram

Status Counter A triple timer/counter counts status pulses from the acquisition section of the board. The status pulses may be used by applications to indicate events occurring in an acquisition pattern.

ECL-To-TTL Conversion The differential ECL signals from the ADC board (D0-D9, FRAME_OUT, LINE_OUT, CKD, and OVERRANGE) are converted to single-ended TTL outputs before being used by the Acquisition/Controller board. A TTL-to-ECL conversion of OLS and PSR to ECL levels is also done. These signals (Sync Reset and Async Set) control the modes of the ADC board so that it either outputs all ones or zeros or does conversion operations.

Data and Address Latches onto the BCD₀₋₁₂ Bus The data from the ADC board are latched into data latches and clocked out by SCLK to resynchronize the data to the clock signal. Controller ASIC loads an address latch with 10 bits of address. Three additional bits (BCD_{13 - 15}) are added from to complete the address. Bits from the control register, /RUN and /STOP, can switch the trigger RAM input from data latch output (normal operation) to address latch output. Switching the trigger RAM input to the output of the address latch allows the CPU microprocessor to access the trigger RAM. The microprocessor then writes a 4-bit pattern into the trigger RAM through a 4-bit enable buffer.

The 13 bits (10 bits of data plus over-range, FRAME, and LSYNC) are sent to the trigger RAM and and to the data acquisition sections of the board.

Trigger RAM The trigger RAM performs the actual word recognition. When the microprocessor writes an appropriate 4-bit wide pattern into the trigger RAM from a 4-bit enable buffer, the four output bits change when certain ranges of input data (identified by bit pattern) occur. The output is four bits of the 16-bit input to the sequencer.

Input data that could be programmed to trigger sequences may include such things as sync, tape dropout, or zero-carrier pulses.

Sequencer (State Machine) Sequencer outputs drive the dynamic settings circuitry and send control bits to the data acquisition board. These control bits cause the program counter on the data acquisition board to jump to preset addresses.

As with the word recognition circuitry, the sequencer static RAM is loaded with program information from the CPU microprocessor. A bit from a control register (SRUN) enables address and data buffers of the system bus to have access to static RAM.

Sequencer Address and Data Buffers. When the address buffer is enabled, the sequencer static RAM can be read and written by the microprocessor from the data buffer before starting the sequencer.

Address Register. The normal input to static RAM is the 16 bits from the sequencer address register. The four TRIG bits, the 16-bit counter CARRY bit, and 11 bits (out of 32) from the output of static RAM comprise the 16-bit input to the register. The TRIG bits are the output of trigger RAM. The 11 address bits are the 11 LSBs from the output of the sequencer static RAM that are also fed through an address latch, to the dynamic settings static RAM as its normal input (nine of these address bits are used in current hardware; the other two are reserved for future expansion.)

Static RAM. The 32-bit word output of the static RAM memory block goes to a number of circuits when the sequencer is running. Eleven bits of the output are fed to an address latch. The same 11 bits are also routed to the address register as the program counter. Sixteen bits of the output are fed as data to the 16-bit counter, while two more bits provide counter control. Three other of these bits provide signalling to the acquisition section of the board.

16-Bit Counter. Sixteen of the 32 bits output by the sequencer static RAM are used as data by the 16-bit counter. The two control bits determine the count direction and whether the counter is to be loaded with the 16 data bits or is to hold the current count. When the counter overflows, the CARRY bit is returned to the address register. The CARRY bit can be used to count samples, lines, frames, or whatever the application needs to count.

Dynamic Address Latch. The 11 bits received by this address latch are clocked through to the dynamic settings static RAM. These are the same 11 address bits that are returned to the address register from the output of the sequencer static RAM, but delayed one clock cycle.

Control Word Latch. The control word latch holds a three-bit control word issued to the data acquisition section of the board. These control bits cause the program counter in the data acquisition section of the board to jump to preset addresses.

Dynamic Settings

This circuitry sends additional front-end control data to the Analog Input, Genlock, and Filter Switch boards. The key requirement for this block is that its outputs must be able to change rapidly, because offset, gain, dither, input selection, and filter selection may change many times during a single line of video.

The CPU microprocessor can access the dynamic settings static RAM any time, even during an acquisition. The same control bit (SRUN) that disables the sequencer static RAM determines if the microprocessor access requires synchronization.

Six of the eight bits sent to the dither generator are used as data; the other two are for control. The dither generator's four control states are the following:

- clear
- sequence to the next dither level

- hold the current level
- load a custom six-bit dither value

Figure 3-9 shows the pre-defined dither waveform sequence built into the dither generator.

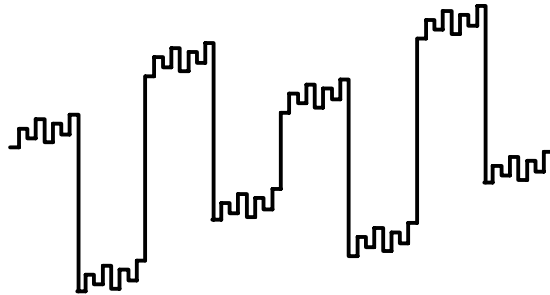

Figure 3-9: Dither generator 64-step dither waveform

When the dynamic settings address buffer is enabled, the CPU microprocessor can read or write the dynamic settings static RAM from the dynamic settings data buffer. This can occur while the sequencer is running. Addresses for the CPU accesses are buffered.

The CPU microprocessor can be given access to the dynamic settings static RAM or the static RAM addresses may be connected to the 11-bit output from the sequencer address latch. The 11-bit output from the sequencer allows for different dynamic output settings for each step of the sequencer program.

The 32 bits of output latches are divided as follows:

- eight offset bits
- eight gain bits
- eight bits to drive a dither generator
- three bits of input selection control
- the CPHASE bit inverts the clock phase on the genlock board to allow sampling midway between previous samples
- four bits control filter selection on the A4 filter switch board

Microprocessor access is also a multiplexed operation.

A DSACK generator provides the rapid signal generation needed for a minimal number of CPU wait states. This DSACK generator is much faster than the DSACK generator in the interrupt controller.

Front Panel Board (A10A1)

The front panel board (Figure 3-10) decodes input from the control knob and touch screen and relays push button and LED information to and from the A10A2 keypad board. The front panel board connector to the display memory board contains most of the lines of the 68008 bus, including lines for relaying push button and LED information to and from the keypad board. Additional lines for power and the signals INTEGRATE and CLK200 are provided.

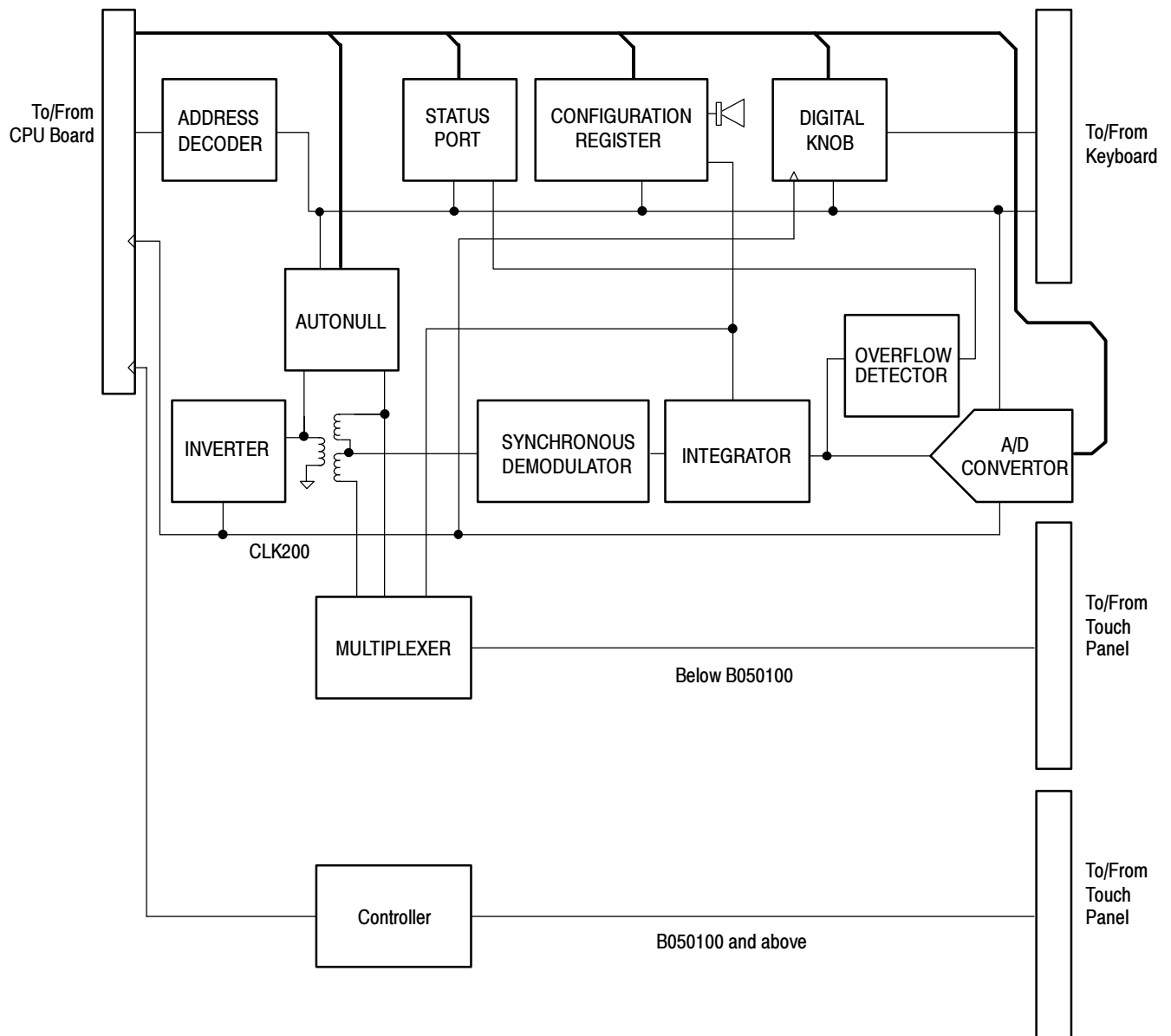

Figure 3-10: Front panel board block diagram

Keypad Board (A10A2)

The VM700T front-panel push buttons, LED, and the control knob are connected to the keypad board. The keypad board is connected to the front panel board through a flex cable that carries power, the 68008 data bus, enable signals from the front panel board's address decoder, and two bits of data from the control knob. Figure 3-11 shows the block diagram of the keypad board.

Control Knob The control knob is a mechanical switch with conductive plastic contacts. One terminal of the switch is grounded and the other two lines are connected to circuitry on the front panel board that decodes the knob's output.

Push Buttons The front panel push buttons are momentary contact, single-pole, single-throw switches divided into two groups of eight and one group of four. The push buttons drive three 8-bit buffers, which are read by the front panel processor (enabled by KEY[0..2]). Firmware provides contact debouncing.

LEDs The front panel LEDs are driven by three 8-bit latches. The front panel processor writes bit patterns into the latches, turning on the appropriate LED.

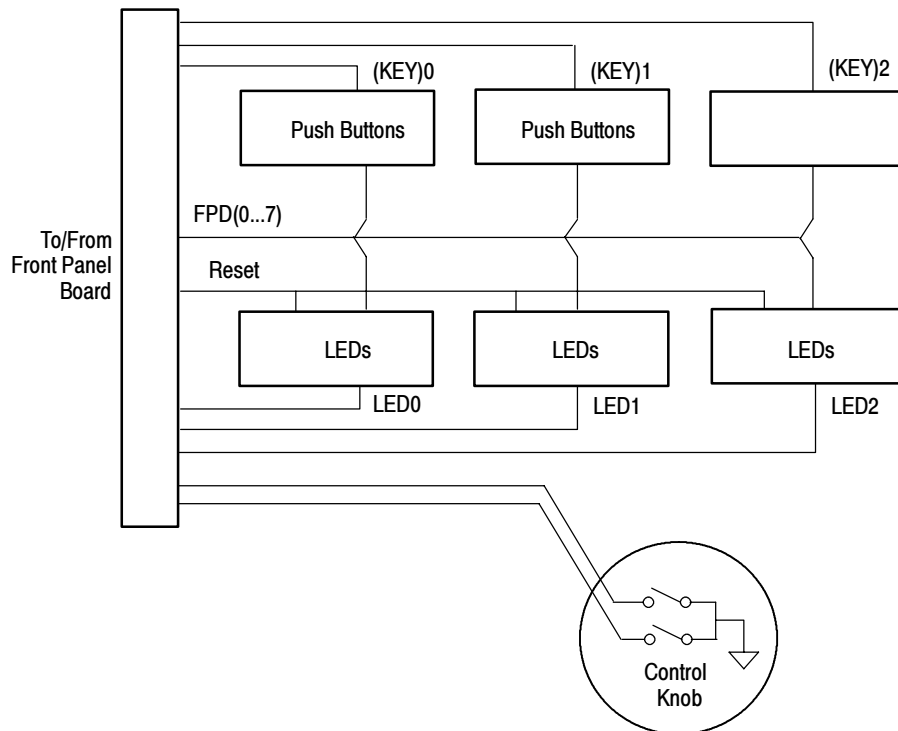

Figure 3- 11: Keypad board (A10A2) block diagram

Main Interconnect Board (Left and Right) (A11)

The VM700T has both attached assemblies and plug in modules. The plug in modules are supplied with power, data, address, and control signals through the interconnections to the Main Interconnect Board. There is a Left and Right board (for the plug in modules on the left and right sides of the VM700T) and an interconnect board that ties the two sides together.

Picture Monitor (A14)

The Picture Monitor produces the visual display of the VM700T. It has vertical and horizontal deflection circuitry to drive the trace on the raster-scan CRT, a video amplifier, the high voltage circuitry, and the CRT in a complete assembly. A simplified block diagram is shown in Figure 3-12.

Video Amplifier

The Video Amplifier amplifies the incoming video signal to levels necessary to drive the CRT cathode. An input circuit provides impedance matching and current drive to the output video amplifier. The output video amplifier drives the CRT cathode. As the input video signal is increasing in amplitude, the inverted video signal drives the cathode negative with respect to its +55V reference level thereby causing the beam current to increase.

+12 V and +5 V Supplies

The incoming +12 V is filtered to provide the +12 V supply. A second +12 V (+12 V₁) is obtained through R295. That voltage is applied to a 5 V zener diode to supply a +5 V source.

Vertical Deflection

The vertical deflection circuit provides the drive current to the vertical deflection yoke. A free-running oscillator circuit produces a ramp signal and an amplified vertical deflection signal. The basic frequency of the oscillator is set to 60 Hz by the adjustment of the VERT HOLD potentiometer. The length of the ramp signal, and consequently the vertical synchronization, is set by the V Sync signal.

When the V Sync is received, the vertical ramp is terminated, and a new one begins. The RAMP OUT amplified to drive the vertical deflection yoke. The vertical height of the display is set by the adjustment of the Vert Size potentiometer. The DC level adjustment of the vertical deflection circuit produces an offset that centers the display vertically. Vertical linearity of the raster is adjusted with the Vertical Linearity potentiometer.

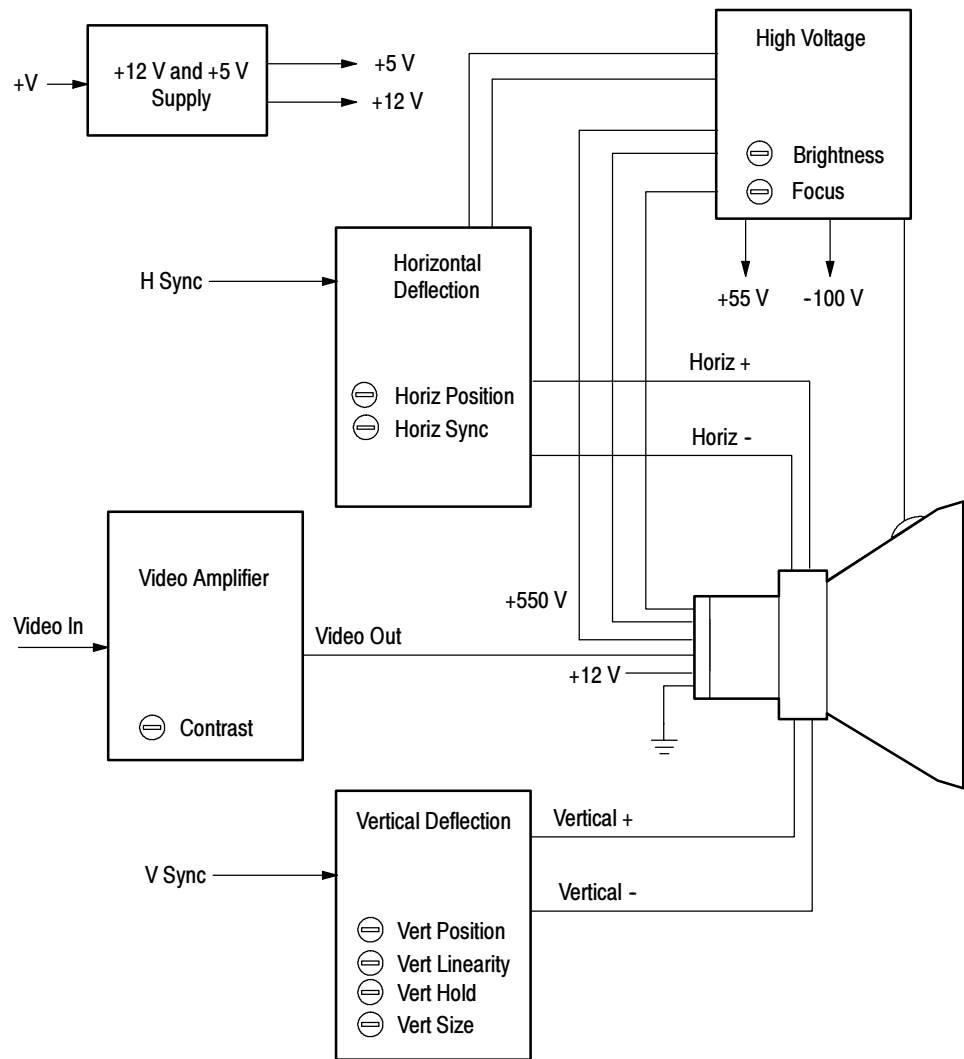

Figure 3- 12: Picture Monitor simplified block diagram

Blanking Amplifier. Blanking between vertical sweeps is produced by the blanking amplifier. In the output of the blanking amplifier, the BRIGHTNESS adjustment sets the level of CRT beam current between blanking pulses.

Horizontal Deflection

The horizontal deflection circuit provides the drive current to the deflection yoke. H Sync is applied a PLL (phase-locked loop) circuit that produces the horizontal deflection signal. The frequency of the loop is synchronized to the incoming H Sync signal after setting the correct frequency with the Horiz Sync control. The output of the PLL is further amplified to drive the horizontal deflection yoke. Width of the display on the CRT is set using the Horizontal Width adjustment. The Horiz Position control adjusts the fine position of the active picture area within the raster-scanned width.

High Voltage The high voltage supply provides the CRT anode voltage, the focus voltage, and the +55 V and -100 V sources.

The main focus voltage is set by the FOCUS potentiometer. Dynamic focusing optimizes the edge focusing of the CRT. The dynamic focusing waveform is shaped to produce the best edge focus in conjunction with the setting of the FOCUS pot for best overall focus.

Trace Rotation The Trace Rotation circuit drives a separate deflection coil on the neck of the CRT. The adjustable voltage from the trace rotation potentiometer provides an overall adjustment range for trace rotation of approximately $\pm 3.4^\circ$.

Power Supply (A15)

The power supply is composed of a primary rectifier, the inverter switching circuit, 12 V and 15 V regulators, alarm-sensing circuitry that monitors for overvoltage, overcurrent, and over-temperature conditions, and the alarm logic circuitry that shuts down the inverter switching circuitry in the event of a problem. A simplified block diagram is shown in Figure 3-13.

Input Power Rectifier The Input Power Rectifier receives the mains AC voltage and rectifies it to provide the drive power to the inverter switching circuitry. A line voltage switch sets the supply to operate on a nominal voltage of either 115 VAC or 230 VAC. Input surge current and overvoltage protection components are included in the input rectifier circuit to prevent major component damage in the event that incorrect line voltage is applied to the AC input.

Housekeeping Power Supply A second power supply provides the housekeeping (or keep-alive) power source. This supply provides power to the logic circuitry that controls the power supply STBY/ON logic circuitry. One of the sensing signals (LINE SENSE) to the power supply logic circuitry is developed from the secondary of the house-keeping supply transformer.

Inverter Switching Circuit This circuitry comprises the Pulse Width Modulator, the Switching Transistor Drivers, the Switching Transistors, and the Secondary Rectifiers and Filters.

Secondary outputs of the power transformer are full-wave rectified and filtered to provide +5 V, -5 V, +16.5 V, and -16.5 V. The +16.5 V and -16.5 V are further regulated to produce the +15 V and -15 V supplies to the VM700T and the +12 V display module power. The source voltage for the Fan Drive circuit is also provided by the +12 V supply.

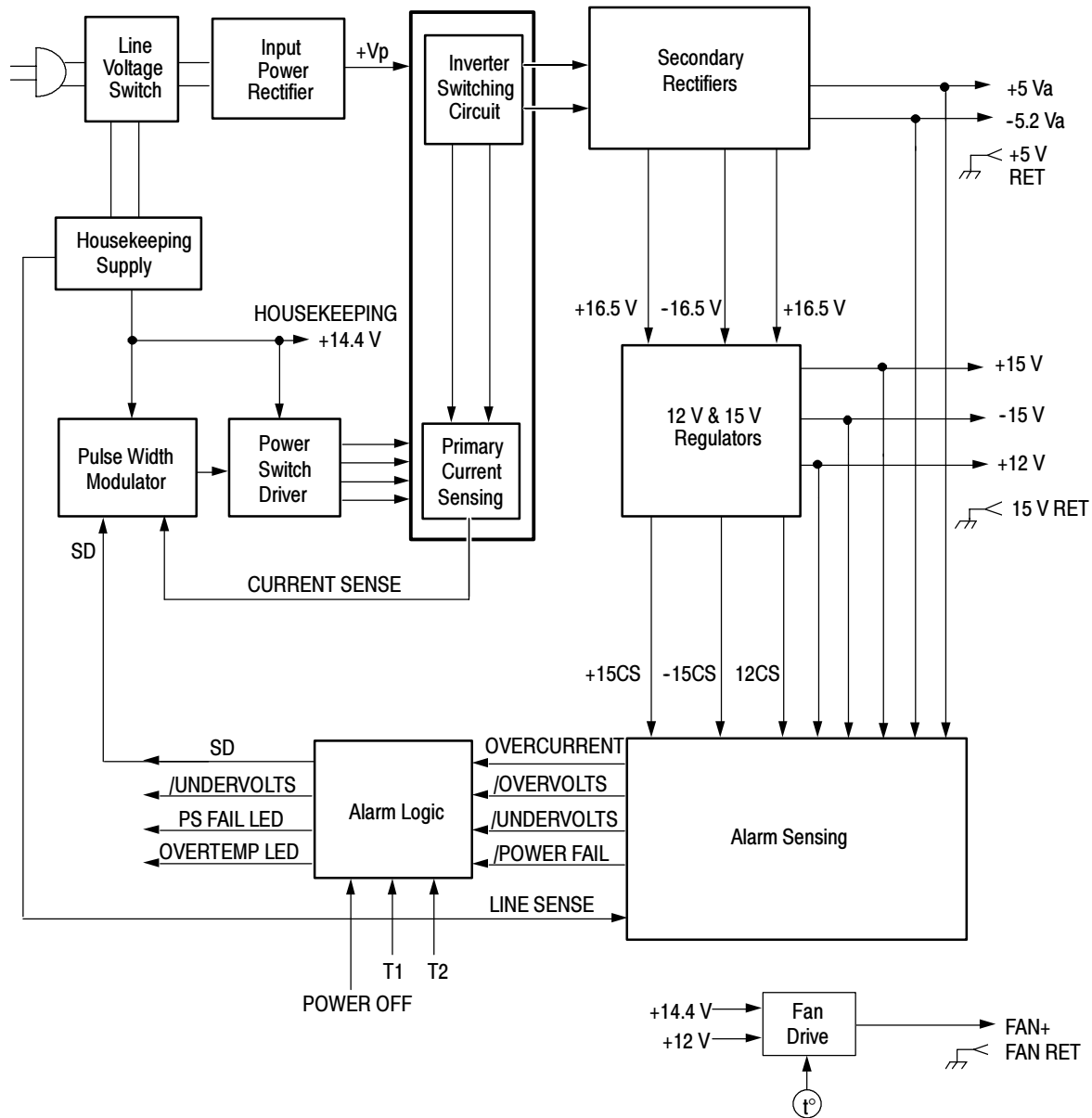

Figure 3- 13: Simplified block diagram of the power supply

+12 V and 15 V Regulators

The +12 V and the + and -15 V regulators are similar in operation. The +12 V regulator is operating with more head room than the + and -15 V regulators, and the circuitry is modified to adjust for that difference. Each regulator is a combined operational amplifier and FET current pass element with a feedback loop to the operational amplifier from the output voltage.

- Alarm Sensing** The Alarm Sensing circuitry looks at the various supply voltages to check for undervoltage, overvoltage, overcurrent, and power fail conditions. The status of these conditions are the signals fed to the Alarm Logic circuitry.
- Alarm Logic** Each of the alarm sensing outputs is monitored by the Alarm Logic circuitry. That circuitry also monitors the temperature sense signals. Depending on the state of the sense signals, the Alarm Logic circuitry can issue a shutdown signal (SD) to the Pulse Width Modulator (PWM) to stop the power supply from operating. The Alarm Logic circuitry also drives the Over Temp LED and PS Fail LED front-panel indicators as feedback to the user of the existing problem.
- Fan Drive** A separate Fan Drive circuit provides a temperature-related drive voltage to the fan. As the temperature rises, the fan is driven faster to compensate for the rise. The temperature sensing element for the voltage control is mounted on the 5 V power supply heat sink.

Option 40 Audio Measurements

This section describes the operation of the VM700T Video Measurement Set audio option boards. The discussion provides the background information needed for fault isolation to the board level and board replacement; it does not include a component-level description (component-level circuit repair is beyond the scope of this manual).

Audio Processor Board (A12)

The following paragraphs discuss the Audio processor board. Refer to Figure 3-14 as you read the discussion.

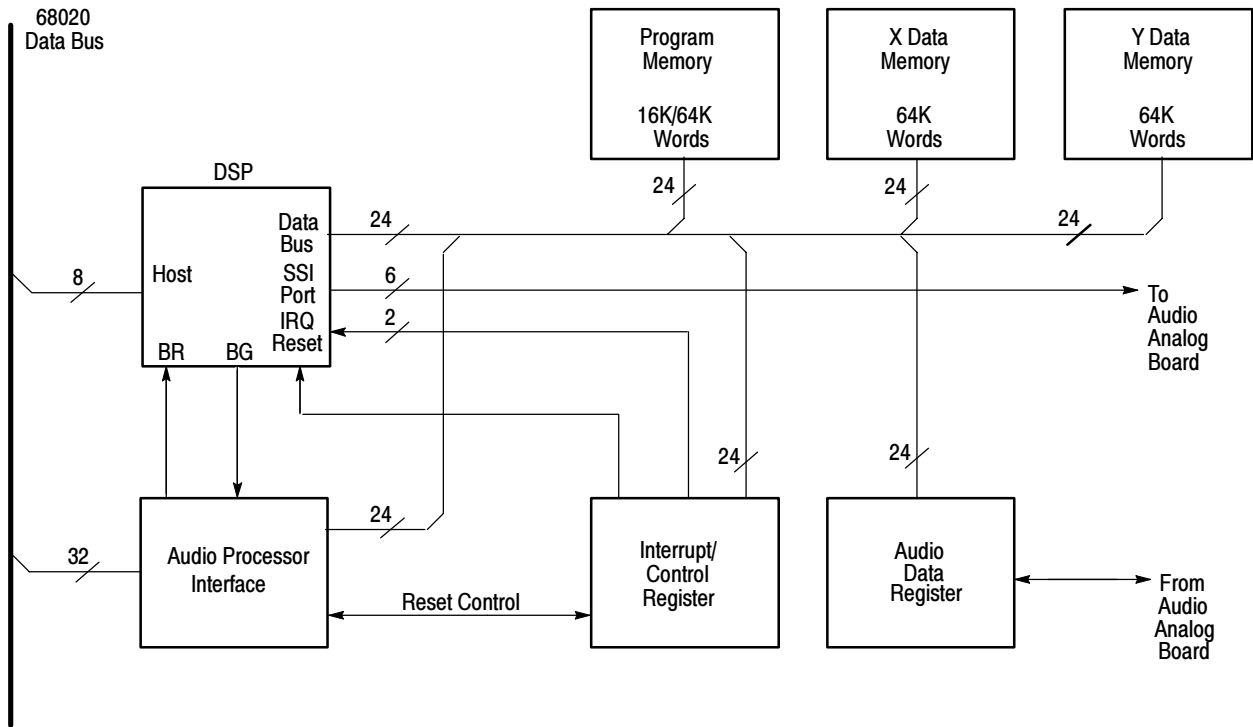

Figure 3- 14: Audio Processor block diagram

Audio Processor Interface

The Audio Processor Interface consists of address decoders, bus buffers, and address buffers.

Address Decoders

Address lines are decoded to provide the various control bits used throughout the audio option boards. Several address decoders are used. One decodes data intended for the Audio Processor board, another decodes the P, X, and Y memory, program memory, and the X-data and Y-data memories. A third decodes the control registers on the Audio Processor board and the interrupt control signals for both the CPU and the DSP.

Bus Buffers

The bus buffers are enabled during bus-to-bus accesses. They are disabled to isolate the busses when bus-to-bus accesses are not being done.

Address Buffers

The address buffers are unidirectional devices that feed the Audio Processor address to the DSP address bus.

Interrupt Generator/Status Port

A function of this 32-bit control register is to control interrupts for the DSP (digital signal processor). It consists of an interrupt generator, data buffers, and read/write registers that hold the data for access when needed.

Interrupt Generator The interrupt generator contains the interrupt control lines for the DSP. The interrupts are generated by audio data. When enabled, left-channel audio data and right-channel generate separate interrupts to keep the channel data separated for processing.

Data Buffers There are several data buffers. One data buffer holds the interrupts, the interrupt enables, and the channel data indicator. The channel data indicator is used to indicate which channel data is held in the audio data register. That register is only big enough to hold one sample, so it will contain either left channel data or right channel data (1 for left, 0 for right).

A second data buffer is a read-only buffer that holds the board version number. Software reads these bits to determine the hardware version installed in the VM700T. Other bits held in the data buffers indicate when a calibration is taking place and show which audio option is installed (Option 40 or Option 41).

Reset Register The reset register hold the reset bit as the last bit in the 32-bit interrupt register. When the audio processor resets, it sets the (RESET) line low to reset the DSP. This line stays low until the audio processor forces it high to start the DSP.

DSP Processor and I/O Interface

The DSP is the heart of the Audio Measurement System. The DSP has a 16-bit address bus and a 24-bit data bus. Devices on the DSP bus include address decoders and buffers used to provides the extra drive needed to drive the memory load (18 memories).

Oscillator A buffered oscillator running at 27.5 MHz provides the drive needed for the external clock input to the DSP.

Communication Ports The communication ports handle parallel data flow between the DSP and the CPU (the Host Port), and serial data flow to the D/A converters and control registers on the analog board. One of the communications ports allows communications between the DSP and the CPU without having to do a bus request/bus grant operation. Another port is divided into two serial ports; one for serial communications and the other is the synchronous serial interface.

Audio Data Register

This register accepts serial data from the ADC on the analog board and converts it to parallel data for the DSP or the CPU. A serial to parallel converter converts the serial data from either the ADC or the DSP (generated for diagnostics) to a 24-bit parallel data word used by the DSP.

CPU Access Disable

If the DSP is set to generate interrupts when audio data arrives, it must service the interrupts in a service routine. At the same time, the CPU can be trying to read or write data to the same address space being used by the DSP. The DSP always gives up its bus to the CPU, but this can cause a problem. To avoid this bus sharing problem, there is circuit that prevents CPU access to the bus during the data interrupt service routine.

Static RAM

The P (program), X (data), and Y (data) static RAM is composed of 18, 25-ns devices. Each RAM is 4-bits wide, so six memory chips are used to make up the 24-bit word. Each pair of chips accessed by the same write enable signal corresponds to one 8-bit byte. Each byte has separate write enables, because the CPU accesses only a byte at a time. The static RAM is connected to the DSP address and data buses.

P Memory

The program memory (the instructions for the DSP) may be held in either 16K X 4 or 64K X 4 memory parts. Jumper connections on the board select the correct device memory size for the parts installed.

X-Data and Y-Data Memory

These memories are the X-data memory for the DSP and the Y-data memory. The DSP also has some small internal P, X, and Y memory. These three internal memories (P, X, and Y) can be accessed at the same time by the DSP. Access to the external P, X, and Y memories is one at a time. These memories are used mainly for storing look-up tables and data and results (for example, fft and other intermediate results are stored here).

Program Loading

The program instructions are loaded into the P memory from the audio processor. The usual action is for the audio processor to set the RESET bit to keep the DSP shut off and download the instructions into P memory. Then, the RESET is removed, and the DSP executes the newly loaded code.

Control Lines

Each memory device has three memory control lines: WE (write enable), CE (chip enable), and OE (output enable). All memory devices are output enabled at the same time; the read enable signals determine which memory is actually accessed by the DSP.

Audio Analog Board (A13)

The following paragraphs discuss the Audio analog board. Refer to Figure 3-15 as you read the discussion.

Input Amplifiers

This section discusses the channel 2 (right channel) input amplifier, but the channel 1 (left channel) input amplifier circuitry and function is the same. The input amplifiers are labeled on the board's back panel.

Signal Input

The channel 2 analog signal enters the board through a 3-pin, mini-XLR connector on the VM700T back panel. This connector is a balanced differential input. From the input, the analog signal is applied to NORM/CAL relay. In normal operation, the relay is not energized, and the signal passes through (Cal operation is described later). The audio differential signal is AC-coupled to remove DC offset from the input signal.

NOTE. *On option 41 boards, the analog signal enters through pins on a DB37 connector rather a mini-XLR connector. On Option 41 boards, relays select one of the three different inputs for each channel. The control signals for these relays travel on the audio-signal ribbon cable (but control and signal lines are isolated by ground runs).*

Stepped Attenuator

From the coupling capacitors, the signal is applied to an attenuator circuit. Each step of the attenuator is 10 dB. The default position provides unity gain (no attenuation). Attenuation steps of 10 dB and 20 dB are selectable.

The top of the range at unity gain is +10 dBu. With a 10 dB attenuator it is +20 dBu, and with the maximum attenuation it is +30 dBu.

NOTE. *Load resistance is not considered in measuring dBu. Similar to dBm, dBu is voltage referenced only.*

Input Amplifier

After exiting the stepped attenuator, the signal is applied to an input clamp circuit. The clamp circuit (± 11.2 V input clamping) protects the operational amplifier by holding its input below the supply voltage (low-noise performance can be degraded or circuit devices can be damaged if input voltage exceeds supply). The nominal signal expected at the input to the amplifier is approximately 3.5 V peak (just over 2 V rms).

The positive half and negative half of the differential signal are applied to operational amplifiers that form an instrumentation amplifier. This is normally a unity gain stage, but it has selectable gain of 10 dB and 20 dB. The attenuator preceding can be 0 (no attenuation), -10 dB, or -20 dB. The differential input

signal is converted to a single-ended signal and common-mode voltage is suppressed or cancelled.

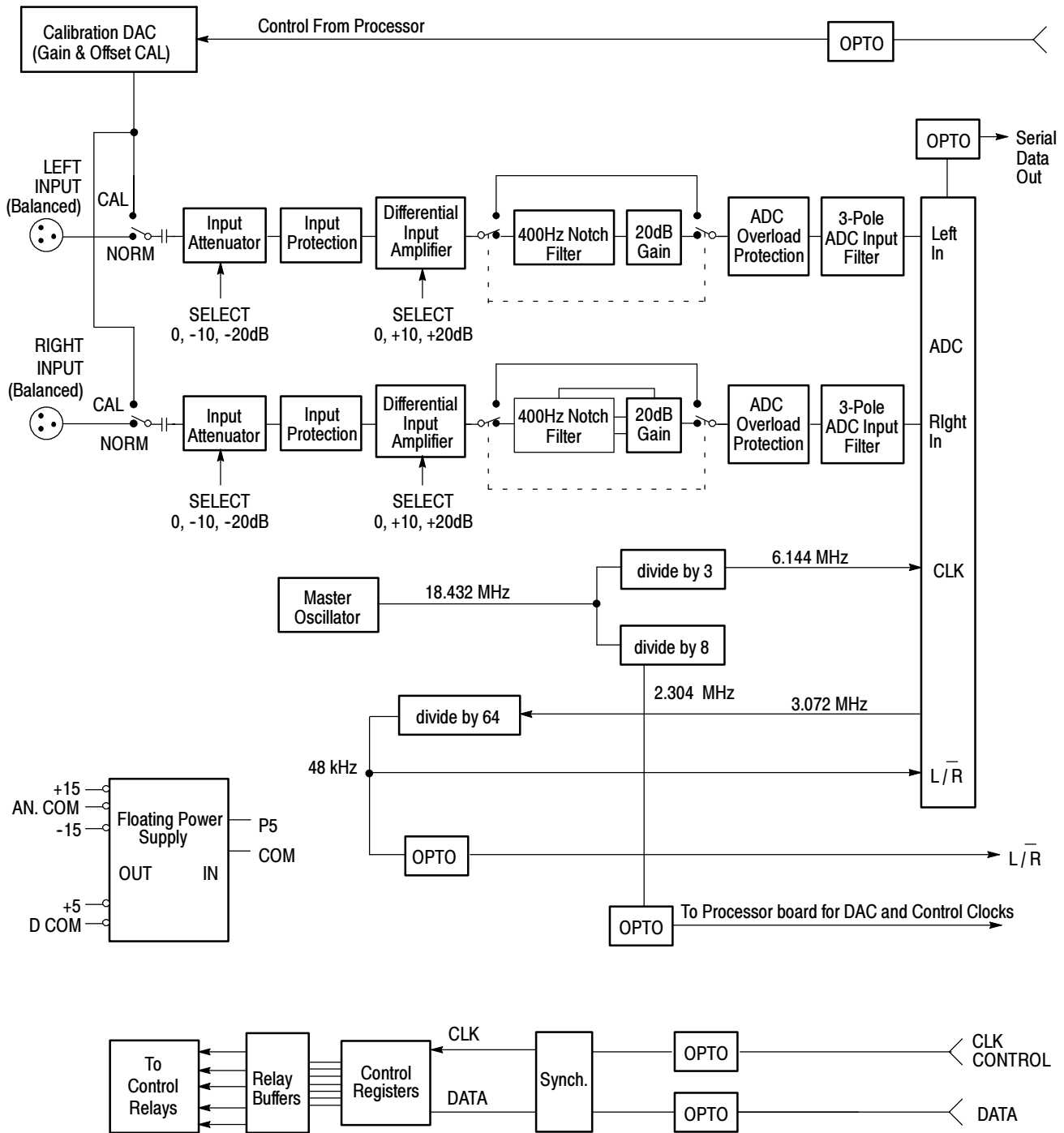

Figure 3-15: Audio Analog block diagram

400 Hz Notch Filter/DAC Output

The signal enters on the left and is applied to the contact arm of a relay that switches the notch filter in or out of the Channel 2 signal path. The filter is normally out. When the relay is energized, the 400 Hz notch filter is inserted in the signal path.

Notch Filter Operation

The notch filter circuitry has a bandpass filter at 400 Hz. The output of the bandpass filter is combined with the input signal. The gains are set 2:1 for a resulting output equal to the input signal minus the bandpass circuit output, forming a notch at 400 Hz. The output of notch filter goes to the A/D converter.

DAC Output

The incoming signal current from the DAC is applied to the summing junction of a high-speed operational amplifier. This circuit converts the incoming current to a signal voltage and applies it to the CAL side of the NORM/CAL relay.

Calibration Signals. There are two calibration signal choices:

- The output of the DAC (used during diagnostics)
- The output a high-speed, solid state switching device. This device selects either ground or a high-precision 5 V reference and is chopped at 120 Hz. The symmetrical square wave developed by the switching is applied to the selected analog input through a coupling capacitor. Capacitive coupling shifts the DC level of the signal to ± 2.5 V. When the chop signal is not running, the output is at ground.

Calibration Channel Selection. A set of relay contacts determine the channel and side of the differential channel input that the calibration signal is applied to. The calibration selections signals drive this set of relays. In the unenergized state, channel 1 gets the calibration signal. The unselected channel is grounded.

Other relays switch the sense of the calibration signal so that both sides of the balanced differential inputs may be calibrated using the single-ended calibration signal. During calibration the noninverting input is calibrated first, grounding the inverting input. When that half is finished, the relays switch to apply the calibration signal to the inverting input to calibrate that side.

Option 40 A/D Converter

The channel 1 and channel 2 circuits are identical; only the channel 2 circuit is discussed here.

Input Clamp

The channel 2 signal is applied to a clamp circuit at the input of the amplifier. This clamp circuit protects the input of the A/D converter. The clamping circuit holds the input signal swing to approximately 4.4 volts peak (positive or negative).

CH 2 (and CH 1) Amplifier

This circuit is actually a 150 kHz, low-pass filter. This filter is a 3-pole Bessel type circuit with exceptional phase performance.

A/D Converter

The A/D converter is a delta-sigma type oversampling converter running at 64 times the required output frequency. In this circuit, the 150 kHz low-pass filter circuit at the input of the A/D converter provides anti-alias protection.

The analog data applied to the inputs of the A/D converter is processed by the converter and output as serial digital data. The left/right channel data is controlled by the L/(R) signal and alternated in the data stream.

A/D Converter Self Cal. The CAL signal applied to the A/D converter causes a self calibration on the falling edge of the signal. During the self cal time, the A/D converter checks the DC offset on its analog inputs. The offset is stored in a register and subtracted from the data sent from the converter. This operation zeros the internal offset of the converter and any offset generated by the operational amplifiers (or any other DC offset) in front of the inputs. Up to 250 mV offsets can be removed, but the usual offsets are not more than 10 mV.

During the Self Cal (offset calibration) a signal is sent to the DSP to keep it from interrupting the A/D converter during calibration. That signal is removed when calibration is complete.

Audio Board Control

Opto-Isolators

The control signals sent between the audio digital and the audio analog board are optically isolated, with one exception. The (CLR) signal, entering the analog board is inverted to a CLR signal. This signal turns on the 2.304 MHz DAC clock when the DAC is operating.

Five opto-isolators isolate the signals between the boards and allow the analog ground on the audio board to float (to remain ungrounded from chassis or earth ground).

Analog board input signals to be isolated enter the board through a buffer. The buffer receives its power from the VM700T.

The input signals enter through two of the opto-isolators (each device is a dual opto-isolator). The signals sent from the isolators are referenced to analog board ground. This means that the analog board digital ground and the digital board ground are not the same.

The other three opto-isolators take signals from the analog board and isolate them for output to the digital board. These signals (associated with the A/D converter) are applied to a buffer to drive the opto-isolators.

The open-collector outputs of the opto-isolators are pulled high, in case a fault causes the lines to be undriven.

Synchronizer The digital signals from the opto-isolators are synchronized to the clock signal.

Counter/Decoder After the signals are synchronized, they go to a counter/decoder circuit. Two of the signals determine the state of operation (diagnostics mode, dumping data to the DACs, or receiving data from the A/D converter).

Control Register The Control Register is a 24-bit register (three 8-bit shift registers) that holds the control word that controls operating states on the analog board. The serial control word is clocked into the shift registers.

The control bits from the relay control register are buffered by relay drivers to drive the state-controlling relays.

Master Oscillator and Clock Divider The master oscillator is an integrated-circuit oscillator generating a signal at 18.432 MHz. The 18.432 MHz signal divided by 3 and reapplied to the A/D converter.

Inside the A/D converter, the 6.144 MHz input clock is divided by 2 to 3.072 MHz and supplied as an output. The 3.072 MHz clock is also provided as an inverted output by the A/D converter.

The 3.072 MHz clock is applied to a multiple divide-by-two divider, where it is divided by 64 to supply the 48 kHz that is the effective sampling rate. That 48 kHz is applied to the L/\bar{R} input of the A/D converter.

The 48 kHz and the 3.072 MHz clock are also sent off the analog board.

The 18.432 MHz signal is also divided by 8 to produce a 2.034 MHz signal used by the digital-to-analog converters. This signal clocks the control word to the control registers.

A control signal used to hold off the 2.034 MHz. When the signal is low, the 2.034 MHz is not generated. The signal is generated only when diagnostics are run or when a new control word is written for changing gain or attenuation.

Calibration DAC

The DAC is an 18-bit D/A converter. Serial digital data sent by the DSP and a clock signal that is replicated by the DSP are applied to the DSP.

A shift register realigns the 24-bit data from the DSP so that valid data is shipped to the 18-bit DAC. The DAC expects leading, not trailing zeros, so the shift register shifts the data six bits for proper alignment.

This DAC circuit is used in diagnostics (discussed later).

The output of the DAC is a current signal is converted to a voltage signal.

Floating Power Supply

The mainframe interconnector provides +5 V and ground from the VM700T. The +5 V powers two low-noise, high-accuracy switching supplies.

One supply provides +5 volts at 1 ampere; the second switching supply provides +15 V and -15 V at 330 mA. This floating power supply isolates the analog circuitry from possible noise sources in the VM700T power supplies.

The + and -15 V supplies are used to provide regulated + and -5V to the analog board through three-terminal regulators. These + and -5 volt analog supplies power the A/D converter and the DAC.

Grounds

Several different grounds are used in the instrument. The grounds are separated to keep ground loop signals and noises from being transferred via the grounding planes of the circuit board.

Option 41 Audio Analog Board

The Audio Analog circuit board, A17A1, is identical to the A13 Audio Analog circuit board in parts and operation. Option 41 provides an added circuit board, A17A2, to do the input channel selection from the three audio inputs. The A17A2 circuit board along with the A17A1 (A13) circuit board make up the A17 circuit board assembly for Option 41.

6 Balanced Input Selector

Selection of the left and right input signal source from one of the three possible inputs of Option 41 is done by a set of relays and a relay selector/driver device on the A17A2 circuit board. Figure 3-16 shows a simplified diagram of the left

input channel switching. The left and right selection relay circuits are identical in operation. For brevity, only the left channel operation is described here.

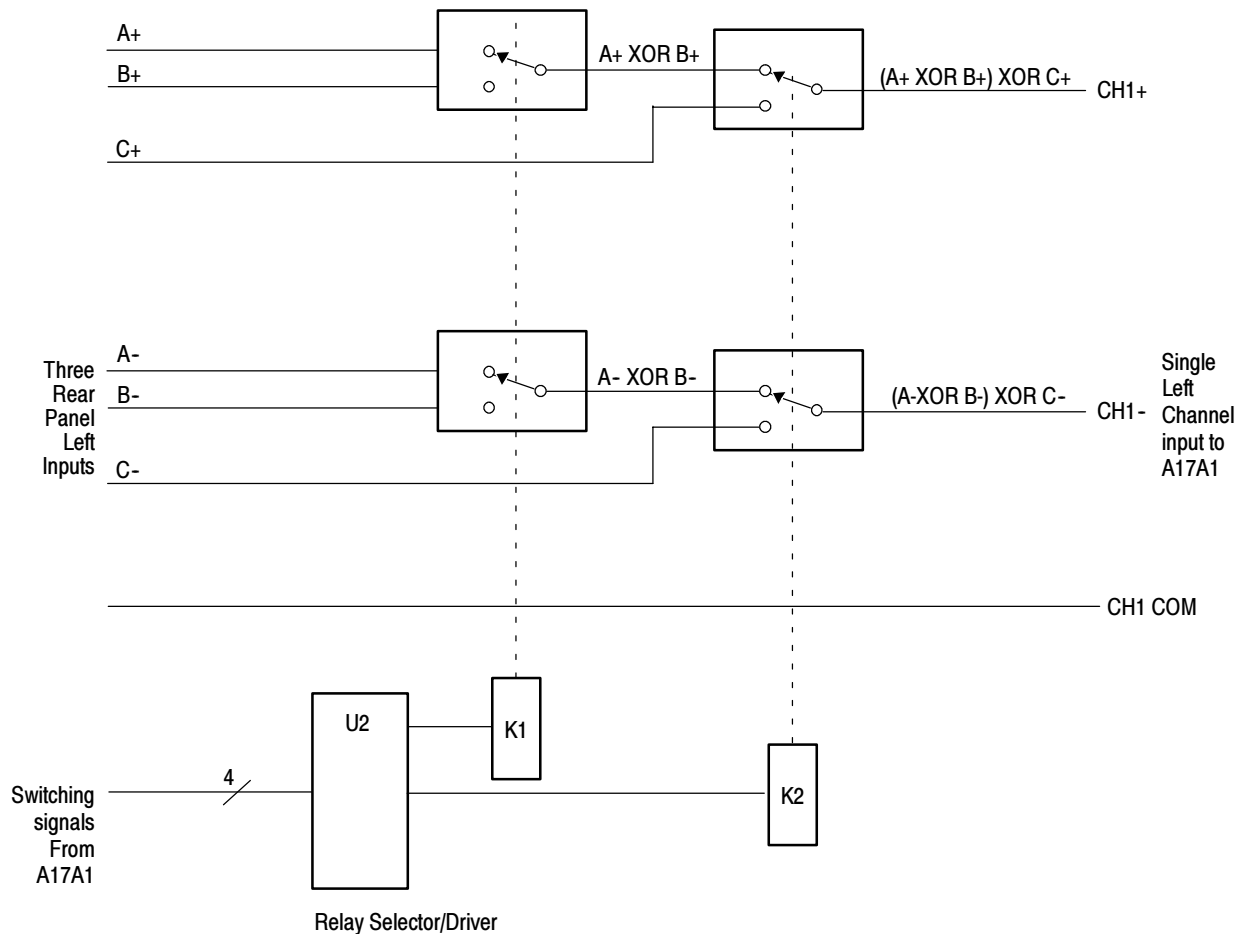

Figure 3-16: Audio Analog block diagram

Source Selection Relays. The contacts of one relay select between input 1 and input 2. A second relay selects either the output of K1 or the source 3L+ and 3L- to apply to the CH1+ and CH1- inputs going to the Audio Analog board. The relays are selected by the input selection signals. Input commons are connected together at the input and applied to the CH1COM input to the Audio Analog board. Filters provide some protection to the Audio Analog board from electromagnetic interference that may accompany the input signal.

Option 48 GPIB Interface Board (A19)

Figure 3-17 shows the installed location of the A19 circuit board in a fully optioned instrument. The GPIB Interface Board (A19) contains a GPIB processor, a GPIB controller, Dual Port RAM, and additional circuitry to handle communication between the GPIB processor and the VM700T processor and communicate with remote devices through the GPIB bus. Figure 3-18 shows the functional blocks and bus interconnections of the GPIB board.

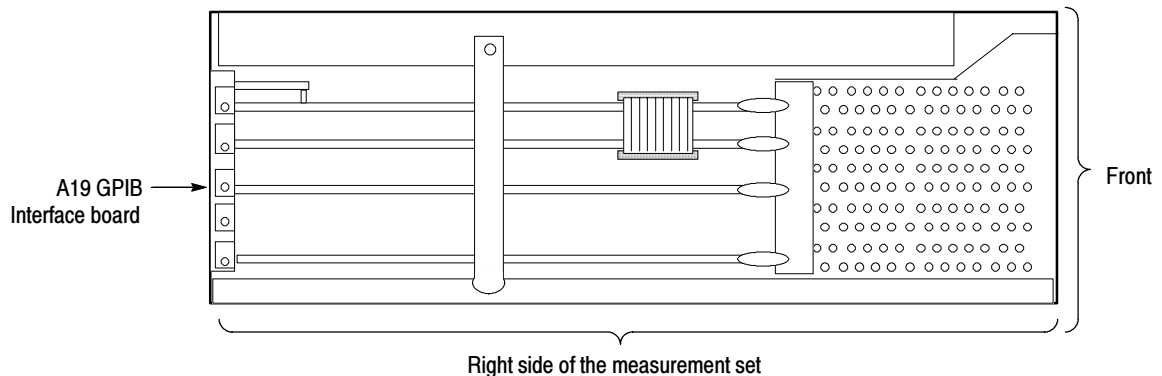

Figure 3-17: GPIB board location in the measurement set

The GPIB processor tracks the state of the GPIB, handles attention messages, and performs protocol conversions. It is a separate processor that is loosely coupled to the main processor in the VM700T by interrupts and shared memory. The shared memory and the interprocessor communications register (IPC register) are accessible by either processor and are used to communicate between the processors. Besides the shared memory spaces, the GPIB processor has some private RAM space that is not directly accessible by the VM700T processor.

The private RAM space is used by the GPIB processor as stack space to hold local variables and intermediate results. Another section of the memory space is the program RAM area. It is treated as ROM space by the GPIB processor and cannot be written to by the GPIB processor. The operating code for the GPIB board is stored in the ROM of the VM700T. On initialization, a copy of that code is loaded into the program RAM space of the GPIB processor by the VM700T processor.

It is not possible for the two processors to access the shared memory at the same time. Either one or the other processor can access the shared RAM space or the IPC register. Both the shared RAM and the IPC register share the same controlling hardware. The Dual Port RAM controller has arbitration circuitry that controls accesses to the shared memory space to prevent contention. When both processors are accessing the shared space, this circuitry alternates accesses so neither processor blocks the other from the shared memory space.

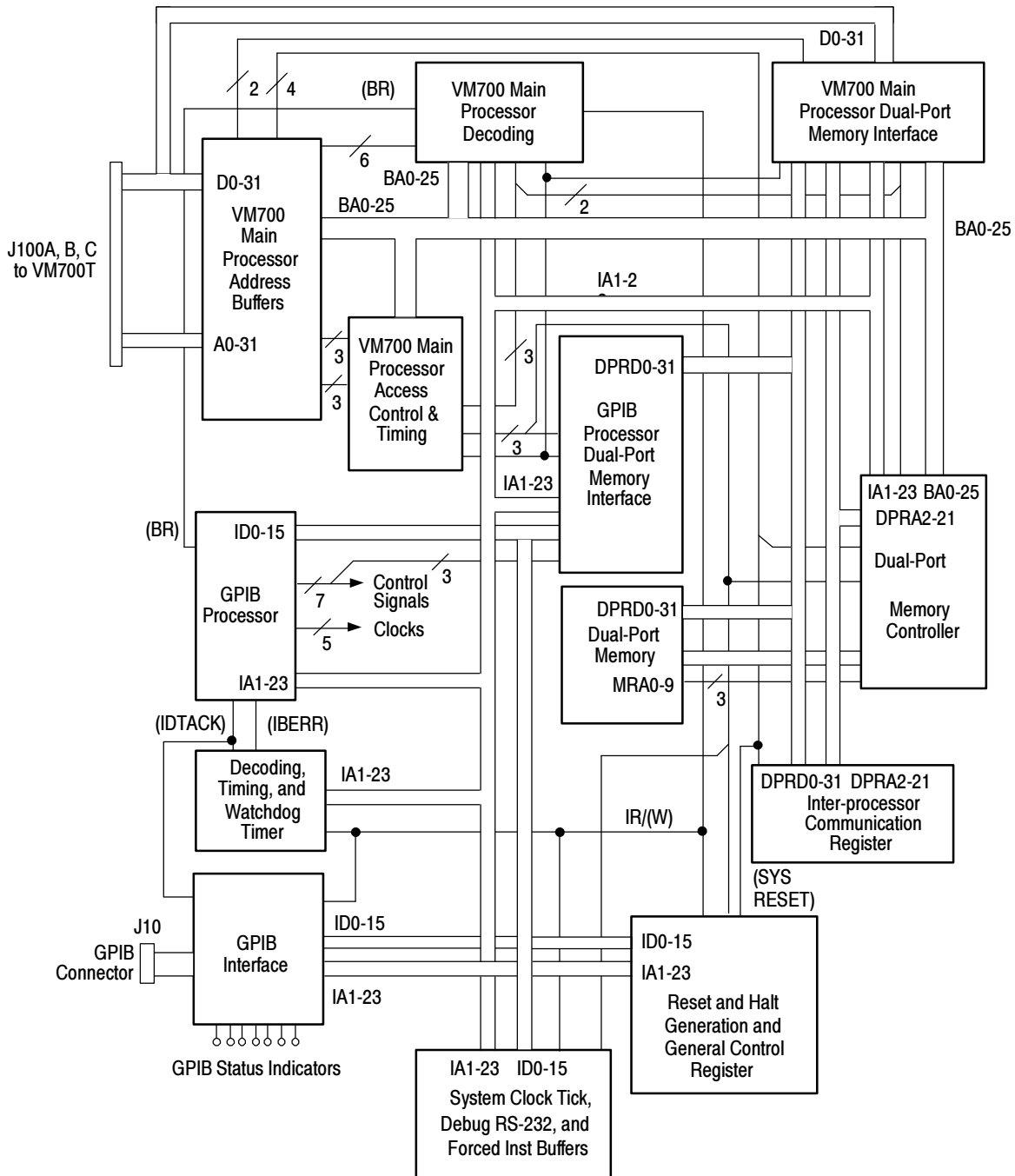

Figure 3-18: Block diagram of the GPIB interface option board

The GPIB processor has no memory cache so it gets its program instructions from the program RAM space. Most of the remaining access time, the GPIB processor is doing reads and writes to and from the shared and private RAM space. It is important that the VM700T processor not be blocked from accessing the shared space so it may communicate with the GPIB processor. In normal operation, when the VM700T processor request access, the Dual Port RAM controller grants it access. However, as long as both processors are making accesses, they will be alternated so that the GPIB processor is not blocked.

During normal operation, communications between the two processors take place through the shared RAM and the IPC register. The IPC register allow either processor to set an interrupt flag to the other processor. When an interrupt occurs, the inter-processor communication is written to buffer then the other processor is interrupted to let it know a message is ready. When the interrupt has finished, the interrupted processor accesses the data to complete the communication.

A second type of access occurs in the debug mode. There is a debug window that allows the VM700T processor to see all 16 Mbytes of the 24-bit addresses of the GPIB processor. Access by the VM700T processor through the debug window halts the GPIB processor. The GPIB processor relinquishes control of its address bus and the VM700T processor takes control. The GPIB processor memory decoding circuitry is used by the VM700T processor to see the address space so the debug window can be used to test most of the GPIB hardware. An exception to this is the GPIB processor interrupts. The VM700T processor has no means to see or handle interrupts to the GPIB processor.

LED status indicators for are on the rear panel of the GPIB interface board. The (LSTN), (TALK), (SREQ), and (CACT) (controller active) bits are all derived from the various control and handshake lines coming from the GPIB controller. Figure 3-19 shows the rear panel and status LED arrangement for the circuit board.

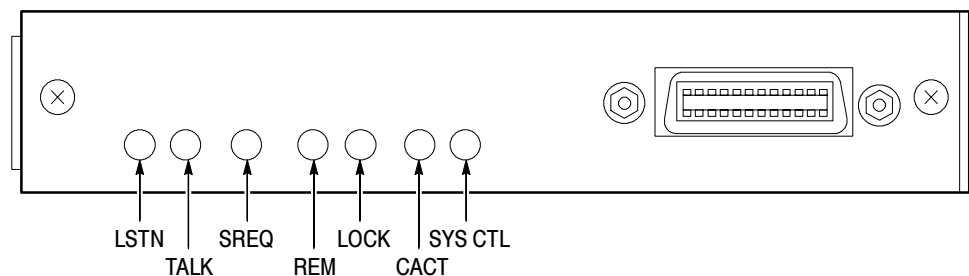

Figure 3- 19: GPIB rear panel arrangement

Option 1S Serial Digital Measurements

Option 1S is composed of three boards: the SDI Rear Panel Interface assembly, the SDI board, and a modified Acquisition Memory board.

SDI Rear Panel Interface Assembly

The SDI Rear Panel Interface assembly contains the low-distortion loopthrough circuitry for both the SDI Channel A and the Analog Reference inputs. For the other signal connectors, the purpose of the assembly is to provide physical connections for the signals into the measurement set.

SDI Board

The SDI board contains the analog and digital processing circuitry for the SDI applications. The board's purpose is to perform a variety of conversions on the incoming signals so they can be acquired by the Acquisition Memory board. The SDI Board is split between a digital signal path and an analog data path. The circuit blocks of each data path, shown in Figure 3-20, is discussed below.

Digital Signal Path. The digital signal path is comprised of the following blocks as shown in Figure 3-20:

Equalizer. For SDI signals, the equalizer actively compensates for the distortions that occur when the SDI signal travels down a length of cable. The equalizer amplifies the signal and reshapes the waveform to make the edges fairly distinct.

Clock Recovery. This block is a phase-locked loop that creates a regular clock from the irregular data transitions that are contained within the SDI stream.

Deserializer. The deserializer takes the SDI data stream from the equalizer, and the clock recovered from the clock-recovery circuitry, to convert the serialized data into 10-bit parallel data. The alignment of the serial data is determined from the embedded TRS marks. Since they are the only data patterns where all 10 bits are either zeros or ones, they provide a clear indication of how the data words are aligned in the SDI data stream.

Line and Frame Synthesizer. This block examines the 10-bit parallel data stream to identify the TRS marks that indicate line and frame transitions. For line transitions, the synthesizer sets the line bit according to the H bit in the TRS XYZ word. For frame transitions, the synthesizer sets the frame bit according to the V bit in the TRS XYZ word. The V bit is deglitched by requiring eight consecutive XYZ words (four lines) with the V bit having the new value before actually setting the V bit itself.

Channel Selection MUX. The channel selection MUX selects between the two SDI channels.

EDH Coprocessor. The EDH coprocessor detects and decodes EDH errors. The coprocessor also participates in the automatic rate detection function.

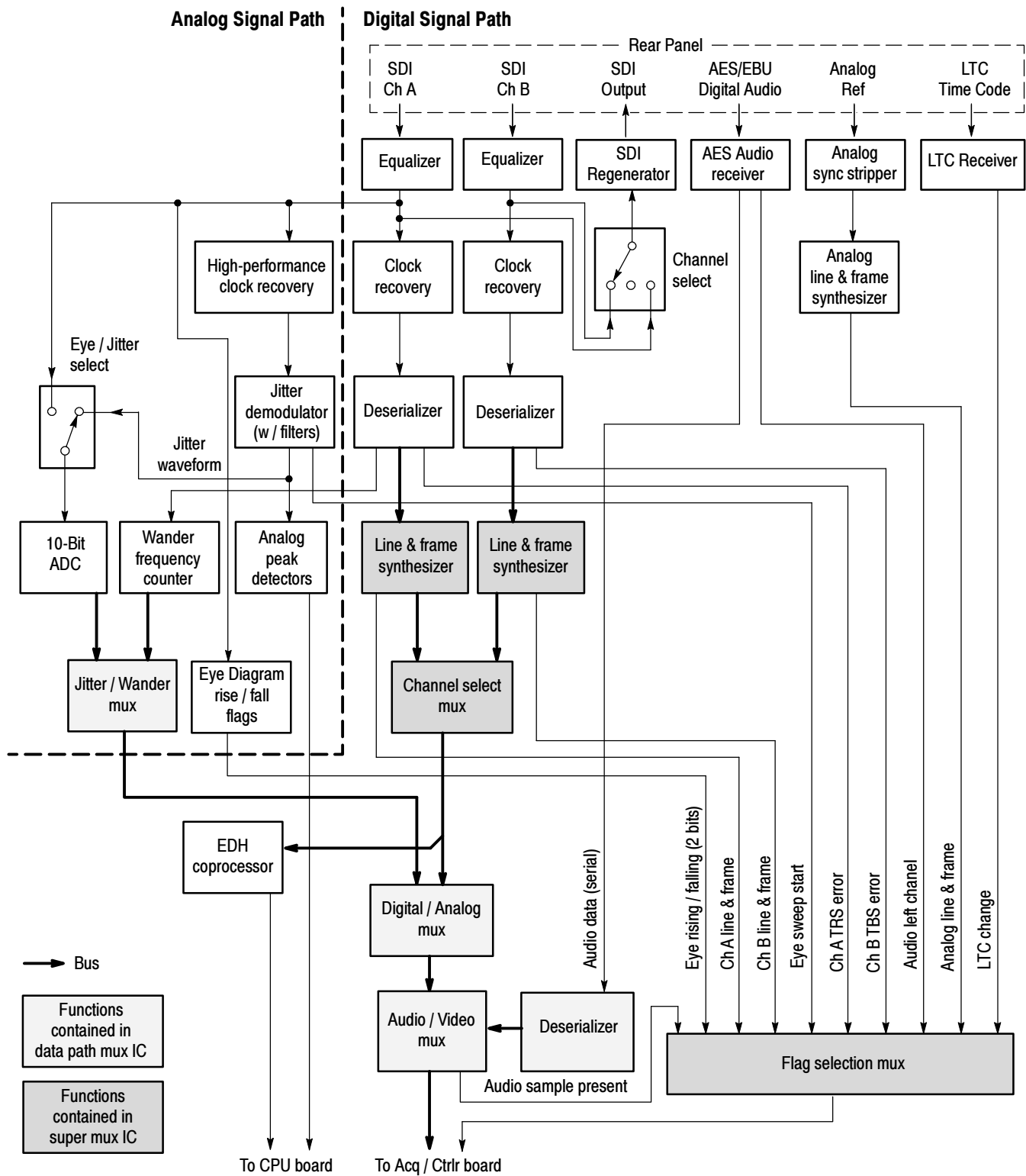

Figure 3-20: Option 1S block diagram

Analog/Digital MUX. The analog/digital MUX selects between the Channel A analog data stream and the digital data stream.

Audio/Video MUX. The audio/video MUX selects between the analog or digital data stream and the audio data stream. It also has the capability to insert the external audio data stream in place of the SDI chrominance samples of the data stream for A/V timing measurements of external audio.

Flag Selection MUX. The SDI board has many status lines that can be multiplexed onto the six flag lines into the Acquisition Memory board. The flag selection MUX controls this mapping.

Analog Data Path. The analog signal path is comprised of the following blocks as shown in Figure 3-20:

High-Performance Clock Recovery. This block performs the same function as the regular clock recovery function block, but it has been calibrated and has a far greater jitter tolerance.

Jitter Demodulator. The jitter demodulator converts timing variations in the recovered clock into an analog voltage. Various filters can be selected for the output that goes to the 10-bit ADC.

Analog Peak Detectors. This block tracks the analog control voltage from the jitter demodulator. The detectors have rapid charging and slow decay.

10-Bit ADC. The 10-Bit ADC block is used to generate the samples for the eye diagram and for the jitter waveform. When fed the raw SDI signal and clocked by the output of the High-Performance Clock Recovery block, the ADC generates Eye information. When fed the control voltage from the jitter demodulator, it generates the jitter waveform.

Wander Detector. The Wander Detector block uses a high-precision oscillator to provide the time base for precise measurement of minute differences in the interval between TRS marks. This timing information is sent down the analog data path for further processing by the instrument software.

SDI Regenerator. The SDI regenerator takes the signal from the equalizer for use as the SDI signal to be output. It does not regenerate the clock.

NOTE. *The signal from the SDI Ch. A input to the SDI regenerator is interrupted whenever an analog application is run.*

AES Audio Receiver. The AES audio receiver recovers the external audio serial data stream. It outputs a serial data stream that is converted to parallel data by the audio/video MUX.

Analog Sync Detector. The analog sync detector recovers line and frame sync from the Analog Reference input signal.

LTC Receiver. The LTC Receiver block translates the LTC signal into registers that can be read by the CPU.

**Modified Acquisition
Memory Board**

The modified Acquisition Memory board contains all the analog circuitry, plus a series of MUX's to select between the analog and digital data streams and to change the handling of the flags portion of the data stream. The Acquisition Memory board also adds a FIFO that allows the controller state machine to communicate information to the CPU without having to place the information in acquisition memory. (This is the FIFO that the SDI_Format application's FIFO Overflow error refers to.)

Performance Verification

The Verification procedures in the this section are done with the covers on the measurement set to verify its operation and may be used to determine the need for readjustment. After a board exchange, certain adjustments may be needed to compensate the overall system performance. Follow the directions found in the adjustment section of this manual when readjustment is needed. Performance to published specifications is verified by other methods during a factory calibration of the measurement set.

Self Diagnostics

You can configure the measurement set to run the diagnostics at power up or to bypass all diagnostics at power up. Refer to *Setting the Power Up Mode* on page 6-70. As received from the factory, the diagnostics are configured to be bypassed for a quicker startup. The diagnostic routines of the VM700T Video Measurement Set check the operation of the digital hardware. Passing the diagnostics is part of the performance verification procedure. Hold down the Menu hard key when you power up the instrument. After about 5 seconds, release the Menu hard key. In the VM700T Startup Menu shown in Figure 4-1, select R - Instrument Run Modes Menu and press the Select Line hard key to display the Run Mode Menu shown in Figure 4-2.

```
Low Level Diagnostic Interface
(knob moves cursor, "Select Line" inputs selection)

--- VM700T STARTUP MENU ---
Key   Selection
-----
R ... Instrument -RUN MODES- Menu
U ... -UTILITIES- Menu
D ... Low Level -DIAGNOSTICS- Menu
C ... Diagnostics -CONFIGURATION- Menu
H ... Diagnostics -HELP- Menu
T ... Calibrate -TOUCH PANEL INTERFACE-
-----
= ... Reprint           @ ... Abort Menu
-----

Input your selection:
```

Figure 4- 1: VM700T Startup Menu

In the Run Modes Menu, select A - Auto Reset. This restarts the measurement set and runs the full set of internal diagnostics. Check that all tests pass as they run. If a test fails, refer to the appropriate text in the *Maintenance* section for further actions you can take to determine which board or boards may be at fault.

Low Level Diagnostic Interface
(knob moves cursor, "Select Line" inputs selection)

--- INSTRUMENT RUN MODES MENU ---

The instrument will be reset to run in the mode selected below, overriding current boot switch settings.

Key	Selection
N ...	NORMAL POWERUP.....Start Instrument in <Powerup Mode> Current <Powerup Mode> is QUICK START; abort this menu and go to the DIAGNOSTICS CONFIGURATION MENU to change it
P ...	POWERUP DIAGS.....Do Diagnostics, start Instrument
Q ...	QUICK START.....Skip Diagnostics, start Instrument
L ...	LOW LEVEL DIAGS LOOPLoop on Low Level Diagnostics
D ...	HIGH LEVEL DEBUG.....Start Instrument in <HL Debug Mode>
A ...	AUTORESET.....Do EXTRA Diagnostics, start Instrument
= ...	Reprint
@ ...	Abort Menu

Input your selection:

Figure 4-2: Instrument run modes menu

Checking for Soft Errors

To check for soft errors (possible intermittent operation), run DiagsLoop on all the high level diagnostics while you let the measurement set warm for 20 minutes before starting the verification checks.

To set up for running all the high level diagnostics in a DiagsLoop, do the following tasks at the completion of system initialization.

- Enter the Configure Directory (shown in Figure 4-3) by pressing the Configure button.
- If you see a Diagnostic Errors file in the Configuration files, either use the Delete soft key to erase it (if it is not needed), or check it for the last error saved and note its time for reference.
- Touch the Diagnostic Selections soft key.
- Set the Diagnostic Selection file (shown in Figure 4-4) to run all diagnostics (refer to *Selecting High Level Diagnostics* for that procedure).
- Select Measure mode by pressing the Measure hard key.

- If the Diagnostic measurements are not shown, touch the Diags soft key to switch to them.
- Touch the DiagsLoop soft key to loop the selected continuously.
- Use the Abort Looping soft key to halt diagnostic looping at the end of the warm up period.
- Return to the Configure menu and check the Diagnostic Errors file for new errors. Refer to the Diagnostics information in the *Maintenance* section of this manual for more information on the diagnostics tests and their operation.

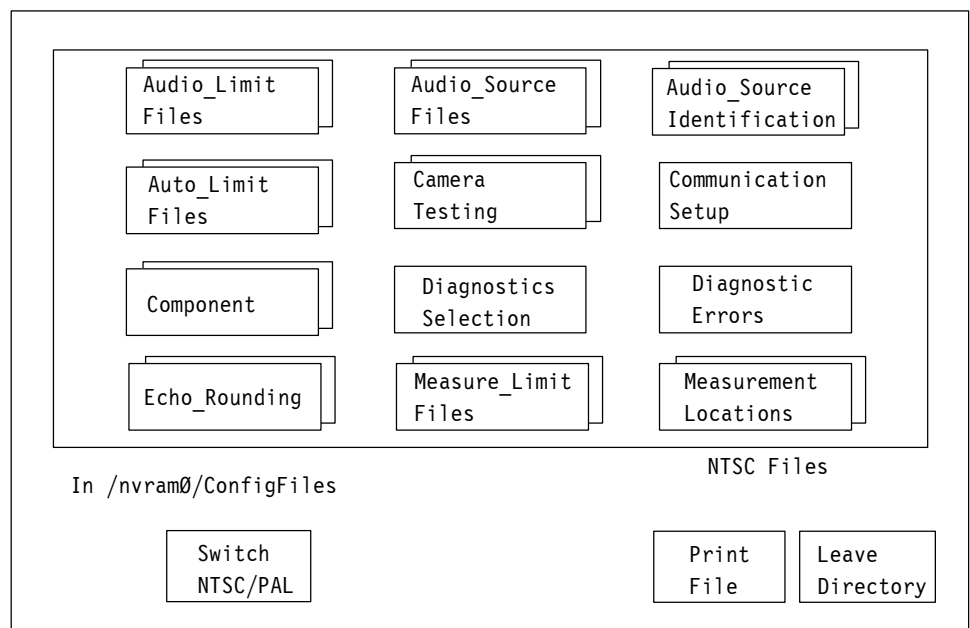

Figure 4-3: Configure directory

Selecting High Level Diagnostics

All diagnostic routines on the “Selected” side execute during Powerup Diagnostics (if not set to Quick Start) and when DiagsLoop is selected. To select or unselect a diagnostic from the Diagnostics Selection file:

1. Press the Configure button.
2. Press the Configure Files soft key.
3. Select the Diagnostics Selection file.
4. Turn the control knob until the name of the diagnostic is highlighted. Touching the vertical center of the left half of the screen selects the highlighted diagnostic; touching the vertical center of the right half unselects it.

5. Press the Update & Exit soft key to write out (save) any changes to the file; press the No change & Exit soft key to leave the file as it was when it was last saved.

Power Up Diagnostics Selection					
Genlock~Diagnostic					
Controller~Diagnostic					
Acquisition~Diagnostic					
ADC~Diagnostic					
AnalogInput~Diagnostic					
FilterBoard~Diagnostic		Rotate control knob to highlight the selection to be made.			
GPIB~Diagnostic					
AudioProcessor~Diagnostic					
AudioAnalog~Diagnostic					
<table style="width: 100%; border-collapse: collapse;"> <tr> <td style="width: 33%; text-align: center;">Selected</td> <td style="width: 33%; text-align: center;">Line 8</td> <td style="width: 33%; text-align: center;">Not Selected</td> </tr> </table>			Selected	Line 8	Not Selected
Selected	Line 8	Not Selected			

Figure 4- 4: Power-up diagnostics selection display¹

As shown in Figure 4-5, the FilterBoard Diagnostic routine is in the Not Selected column and will not be performed.

Power Up Diagnostics Selection					
Genlock~Diagnostic					
Controller~Diagnostic					
Acquisition~Diagnostic		Touch this side of the screen to deselect the highlighted choice.			
ADC~Diagnostic					
AnalogInput~Diagnostic					
GPIB~Diagnostic		FilterBoard~Diagnostic			
AudioProcessor~Diagnostic					
AudioAnalog~Diagnostic					
<table style="width: 100%; border-collapse: collapse;"> <tr> <td style="width: 33%; text-align: center;">Selected</td> <td style="width: 33%; text-align: center;">Line 8</td> <td style="width: 33%; text-align: center;">Not Selected</td> </tr> </table>			Selected	Line 8	Not Selected
Selected	Line 8	Not Selected			

Figure 4- 5: Diagnostic selection file showing an unselected choice

¹ The AudioProcessor Diagnostic and AudioAnalog Diagnostic selections are available only with the VM700T Audio option. GPIB~Diagnostics is added to this list when the GPIB option is installed.

Diagnostic Errors (File)

When high-level diagnostics are run, any errors detected are written to the Diagnostic Errors file. The contents of this file can be printed using the Print File soft key, or the file can be deleted using the Delete soft key.

If diagnostic errors appear, refer to the *Diagnostics* information starting on page 6-55.

The maximum capacity for the Diagnostic Errors file is 100 lines. If the number of errors detected causes the file to exceed this length, the earlier results are scrolled out of the file buffer. When this occurs, the Diagnostic Errors file includes a message stating that some of the text has been scrolled out of the file.

Test Equipment Required

The test equipment to use for performing the verification procedures is shown in Table 4-1. Test equipment suggestions for use in doing the verification procedure are given in the example column. The examples given are based on the test equipment that many customers and the Tektronix service centers have installed for supporting the VM700 family of video measurement sets. Substitute test equipment may be used if available. Refer to the Minimum Specification column to determine the key specifications needed to verify the accuracy of the VM700T Video Measurement Set.

Table 4- 1: Test equipment required for verification

Test Equipment	Minimum Specification	Purpose	Example
Video amplitude calibrator	Square wave 0.0 mV to 999.9 mV peak; accuracy 0.05%, resolution 0.1 mV	Reference standard for amplitude verification	Tektronix 067-0916-00 (not currently available for purchase) ¹
Leveled sine-wave generator	75 Ω output impedance; output flat within ± 0.025 dB ($\pm 0.3\%$) to 6 MHz	Measure sine wave, check filter flatness	Hewlett-Packard 3336C Sine-wave generator with option 005 ²
Television signal generator	NTSC, full field and burst capability, accurate to ± 1 Hz	NTSC test signal source	Tektronix TSG-170A or equivalent
Television signal generator	PAL, full field and burst capability, accurate to ± 1 Hz	PAL test signal source	Tektronix TSG-271 or equivalent
Coaxial cable, BNC connectors	75 Ω impedance, high-quality noise free; 1-meter length	Signal interconnections	Tektronix part number 012-0074-00
Termination	75 Ω precision, BNC connectors	Signal termination	Tektronix part number 011-0102-01

¹ The example amplitude calibrator requires a TEGAM TM500 or TM5000 series power module.

² The flatness accuracy required of the leveled sine-wave generator is only to the bandwidth needed to perform the measurement set verification and adjustments. It is not specified to be that flat over the entire bandwidth of the generator.

System Verification Procedures

NOTE. *If the results yielded by the verification procedures in this section are within the limits specified, further adjustment is not necessary and is not recommended. Adjusting the measurement set unnecessarily (for example, to get a “better” reading on a calibration result that is within limits) can introduce errors into a functional instrument.*

NOTE. *This equipment requires a 20 minute warm-up period before starting the verification procedures. The measurement set must be powered on for at least 20 minutes.*

Measure Squarewave

This procedure checks the amplitude accuracy of the instrument. An externally applied precision reference signal is used to check the complete signal path through the measurement set.

Test Equipment Required

- Video amplitude calibration fixture (VAC). Tektronix 067-0916-00.
- Coaxial cable, 75 Ω high-quality noise free; 1-meter length. Tektronix 012-0074-00.

Procedure: Measure Squarewave

1. Connect the VAC to channel A of the measurement set (leave the input unterminated).
2. Set the controls of the VAC for NTSC, +LUM, and 700.0 mV.
3. On the measurement set, press the Measure key, the Diags soft key (if not already in Diagnostics mode), and the Measure Squarewave soft key.
4. Check the measurement set for a reading of 700 mV \pm 2.1 mV.

NOTE. *If the voltage measured in step 4 is out of the specified limits, go to Adjust the Calibration DAC on page 5-9 in the Adjustment Procedure section.*

5. Move the test signal and select the appropriate channel to repeat the check for channel B and channel C.
6. Disconnect the VAC from the measurement set.

Measure Sinewave

This procedure is to be used as a check for proper measurement set system level adjustment. It checks the frequency response flatness over the instrument's operating range.

Test Equipment Required

- Leveled sine-wave generator, 75 Ω output impedance, output flat within ± 0.025 dB ($\pm 0.3\%$) to 6 MHz. Example: HP 3336C with option 005.
- Termination, 75 Ω precision BNC. Tektronix 011-0102-01, or equivalent.
- Coaxial cable, 75 Ω high-quality noise free; 1-meter length. Tektronix 012-0074-00.

Procedure: Measure Sinewave

1. Connect the leveled sine-wave generator output to the measurement set channel to be tested (start with channel A). Terminate the channel loop-through output connection in 75 Ω .
2. Set the leveled sine-wave generator for 50 kHz at an output level of 500 mV into 75 Ω .

NOTE. *If the example leveled sine-wave generator is being used, the output level should be set for -3.81 dBm.*

3. Press the Measure hardkey, then, if necessary, display the measurement set Diagnostics directory by pressing the Diags soft key. In diagnostics, run the sine-wave measurement application by pressing the Measure~Sinewave soft key.
4. After the measurement application has initialized, turn Averaging on by pressing the Average hardkey until the Average hardkey light is lit. When the display stabilizes, press the Freeze hardkey. The Delta Amp reading should remain at 0. If the Delta Amp reading changes, press the Freeze key again, as many times as needed, until the Delta Amp reading remains at 0. This is now the reference to which all other measurements are compared.
5. Set the leveled sine-wave generator for a frequency of 4.43 MHz; do not change the output level.
6. To speed up the response to the frequency change, toggle the Average hardkey off, then back on again after the display has re-stabilized.
7. Check that the amplitude is within $\pm 0.5\%$ (Delta Amp of $\pm 0.5\%$ or less) of the 50 kHz reference level stored in step 4.
8. Set the leveled sine-wave generator for 5.8 MHz; do not change the output level.

9. Again, to speed up the response to the frequency change, toggle the Average hardkey off, then back on again after the display has re-stabilized.
10. Check that the amplitude is within $\pm 0.55\%$ of the reference level stored in step 4.
11. Change the TV Standard parameter from PAL to NTSC by pressing the XY Arrow hardkey. Change the filter selection from No Filter to the NTSC bandwidth limiting filter by pressing the Move/Expand hardkey until the filter displays NTSC BW Lim.
12. Return the leveled sine-wave generator to 50 kHz; do not change the output level.
13. To speed up the response to the frequency change, toggle the Average hardkey off, then back on again after the display has re-stabilized.
14. Check that the amplitude is within $\pm 0.5\%$ of the reference level stored in step 4.
15. Reset the leveled sine-wave generator for 3.6 MHz; do not change the output level.
16. To speed up the response to the frequency change, toggle the Average hardkey off, then back on again after the display has re-stabilized.
17. Check that the amplitude is within $\pm 0.5\%$ of the reference level stored in step 4.
18. Change the Filter parameter from NTSC BW Lim to Chroma BP by pressing the Move/Expand hardkey. Don't change the settings on the leveled sine-wave generator.
19. To speed up the response to the filter change, toggle the Average hardkey off, then back on again after the display has re-stabilized.
20. Check that the amplitude is within $\pm 0.5\%$ of the reference level stored in step 4.
21. Change the TV standard parameter to PAL by pressing the XY Arrow hardkey.
22. Change the leveled sine-wave generator frequency to 4.43 MHz; do not change the output level.
23. To speed up the response to the frequency change, toggle the Average hardkey off, then back on again after the display has re-stabilized.
24. Check that the amplitude is within $\pm 0.5\%$ of the reference level stored in step 4.
25. Repeats steps 1 through 7 for channel B and channel C.

26. Disconnect the test equipment from the measurement set.

NOTE. *If the response on channel A is out of limits, go to Adjusting Filter Flatness on page 5–6 in the Adjustment Procedure section of this manual.*

If either channel B or channel C does not pass but channel A does, the Analog input board may need replacement. Check with your nearest Tektronix representative or factory service for assistance and board replacement information.

Measuring the Burst Frequency

This procedure checks the calibration of the internal oscillator using a signal source of known frequency.

NOTE. *To successfully run this procedure, the internal oscillator of the measurement set must be completely stable. Power on the measurement set at least 20 minutes before performing this procedure.*

Test Equipment Required

- Television signal generator with full field and burst capability, accurate to ± 1 Hz. Tektronix TSG-170A or equivalent.
- Coaxial cable, 75 Ω high-quality noise free; 1-meter length. Tektronix 012-0074-00.
- Termination, 75 Ω precision BNC. Tektronix 011-0102-01 or equivalent.

Specification Checked

Burst frequency accurate to ± 10 Hz using the internal frequency reference.

NOTE. *The frequency of the signal generator used must be accurate to ± 1 Hz to ensure a valid limit check reference on the burst frequency measurement.*

Procedure: Measuring the Burst Frequency

1. Disconnect all signal inputs from the measurement set.
2. Press the Measure hardkey and touch the Video soft key, if necessary, to recall the Video measurement menu.
3. Touch the Burst Frequency soft key. With no signal applied, the measurement set displays a warning message that tells you to check the signal source because a signal cannot be found. The burst frequency measurement starts automatically after 3 seconds (the Loss of Sync indicator blinks).

4. Press the Menu hardkey and touch the Reference soft key in the menu display.
5. Touch the Zero Set soft key to set the measurement reference for the internal oscillator.
6. Connect the signal generator (full field and burst) to the channel A input (terminate the loop through with a 75 Ω BNC termination).
7. Check that the burst frequency measurement is 0 ± 10 Hz using the internal frequency reference.

NOTE. *If the measurement result obtained is outside of the specification limits, go to Adjusting the Genlock Voltage-Controlled Oscillator on page 5-3 in the Adjustment Procedure section.*

Audio Option Verification Procedure

The procedures in this section are designed to verify the operation of the VM700T Video Measurement Set Audio Option 40 and Audio Option 41. Before performing these procedures we recommend that you run the audio option diagnostics to ensure that the Audio Processor and Audio Analog boards are working properly. Refer to the *VM700T Option 01 (NTSC) & Option 11 (PAL) User Manual* or the *VM700T Video Measurement Set Service Manual* for information on how to select and run the Audio Option diagnostics.

NOTE. *Performing the following procedures requires the fabrication of non-standard adapters and cables. These are used to connect a sine-wave generator to the VM700T audio option. The following list of test equipment describes the cable ends needed; except for the provided female-XLR-to-male-mini-XLR adapter cable, locating the components and fabricating the cables is the responsibility of the user.*

Test Equipment Required

The test equipment needed to perform the verification procedures is listed in Table 4-2. Test equipment suggestions for use in doing the verification procedure are given in the example column. The examples given are based on the test equipment that many customers and the Tektronix service centers have installed for supporting the VM700 family of video measurement sets. Substitute test equipment may be used if available. Refer to the Minimum Specification column to determine the key specifications needed to verify the accuracy of the VM700T Video Measurement Set Audio option

Table 4-2: Test equipment required for verification procedures

Equipment	Minimum specification	Purpose	Example
Sine-wave generator	Frequency accuracy, $\pm 0.01\%$; level flatness (20 Hz to 20 kHz), ± 0.05 dB; level accuracy (20 Hz to 20 kHz), ± 0.2 dB; residual distortion, 0.0010% (-100 dB)	Required for all Option 40 and Option 41 verification procedures	TEGAM SG5010 (two are needed to check distortion measurement accuracy) ¹
Adapter cable, three banana plug to one male XLR, 2 required	XLR connectors must be wired to current AES recommendations: pin 1 ground, pin 2 hot, pin 3 cold	Connects sine-wave generator to adapter cable supplied with VM700T Option 40	E-Z-Hook #5023-xx or equivalent
Female-XLR-to-male-mini-XLR adapter cable, 2 required	Supplied with VM700T Option 40	For level accuracy, level flatness, frequency, and phase measurement accuracy procedures	Supplied with Option 40
Dual female XLR to single male XLR connector	XLR connectors must be wired to current AES recommendations: pin 1 ground, pin 2 hot (+), pin 3 cold (-). See Figure 2-12 on page 2-19 for XLR connector pin locations.	In distortion measurement procedure, connects two sine-wave generators to one Option 40 input	Fabricated by user
Dual male XLR to single female XLR connector (mates with 2 female-XLR-to-male-mini-XLR adapter cables)	XLR connectors must be wired to current AES recommendations: pin 1 ground, pin 2 hot (+), pin 3 cold (-)	In frequency and phase measurement accuracy procedure, used to apply signal from one sine-wave generator to both Option 40 inputs	Fabricated by user
Dual female XLR to DB-37 female adapter cable.	XLR connectors must be wired to current AES recommendations: pin 1 ground, pin 2 hot, pin 3 cold. See Figure 2-14 on page 2-20 for pin outs of the VM700T female DB-37 connector.	Used to connect the sine-wave generator to the triple VM700T audio inputs of Option 41	Fabricated by user (a DB-37 connector is included with Option 41)

¹ The TEGAM SG5010 sine-wave generator requires a TEGAM TM500 or TM5000 series power module.

NOTE. Before performing the level accuracy procedure, Verify the sine-wave generator level at 120 Hz by measuring with an accurate AC voltmeter such as a HP 3458A Digital Voltmeter. You may also use an AC voltage calibrator such as a Fluke 5700A for this measurement. Verify that the sine-wave generator can meet the amplitude accuracy specifications listed in Table 4-2.

Audio Option 40 Verification Procedure

Use the following procedures to check the Option 40 Audio Option.

Check Level Measurement Accuracy and Flatness

This procedure verifies flatness and measurement accuracy by checking signal levels at specified frequencies.

NOTE. *The actual frequencies and levels checked are not specified in this procedure. If the measurement accuracy of certain frequencies and levels is important to your application, we recommend that your test procedure include those frequencies and levels.*

Specifications Checked

Table 4-3 lists audio option accuracy and flatness specifications.

Table 4-3: Accuracy and flatness specifications

Frequency range	Level range ¹	Accuracy (includes flatness)	Flatness
20 - 40 Hz	≥ -20 dBu	+ 0.3 / - 0.2 dB	+ 0.1 / - 0.2 dB
	- 20 dBu to - 50 dBu	+ 0.4 / - 0.3 dB	+ 0.1 / - 0.2 dB
	- 50 dBu to - 60 dBu	+ 0.6 / - 0.5 dB	+ 0.2 / - 0.3 dB
	- 60 dBu to - 70 dBu	± 1.0 dB	+ 0.4 / - 0.5 dB
40 Hz - 20 kHz	≥ -20 dBu	± 0.2 dB	± 0.1 dB
	- 20 dBu to - 50 dBu	± 0.3 dB	± 0.1 dB
	- 50 dBu to - 60 dBu	± 0.5 dB	± 0.2 dB
	- 60 dBu to - 70 dBu	± 1.0 dB	± 0.4 dB

¹ Level difference between channels is ±0.2 dB at levels of -50 dBu and greater.

Option 40 Level Accuracy and Flatness

1. Power on the VM700T and associated test equipment and let them warm up for 20 minutes.
2. Connect the sine-wave generator to the VM700T audio option left and right mini-XLR input connectors. See Figure 4-6 for an example of cabling.

NOTE. For this connection, you may want to use the two female XLR to male mini XLR adapter cables supplied with the VM700T. If you do, you will need to furnish or fabricate an adapter on the signal generator end.

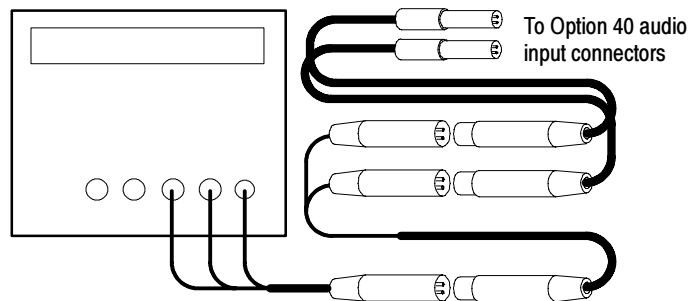

Figure 4-6: Option 40 cable connections, level accuracy and flatness check

3. Press the Measure hard key, select Audio, and run the Audio Analyzer measurement.
4. Using a known accurate sine-wave generator (or one verified with an accurate AC voltmeter), apply a 120 Hz input to the Audio option at amplitudes ≥ -20 dBu (for example, +18, +8, -2, -12 dBu) and verify that the level accuracy is ± 0.1 dB.
5. Select at least 6 frequencies and 10 amplitudes over the listed range to test. The frequencies and amplitudes you select must be in the ranges listed in Table 4-3 (use a signal amplitude level of -70 dBu to test for worst case). Table 4-4 shows an example selection of test frequencies and amplitudes.

Table 4-4: Example test signals for level and flatness test

Frequency	Amplitudes
30 Hz	-10 dBu, -21 dBu, -40 dBu, -49 dBu,
100 Hz	-51 dBu, -55 dBu, -59 dBu,
1 kHz	-61 dBu, -65 dBu, -70 dBu
5 kHz	
12 kHz	
20 kHz	

6. Set the sine-wave generator for each of the frequencies and amplitudes you have selected to test.

7. At each frequency, check that the measured level is accurate to the limits shown (record the level for each frequency).
8. Verify that any differences between the measured levels recorded for each frequency are within the flatness specification given in Table 4-3.

Check Distortion and Distortion Measurement Accuracy

This procedure verifies that residual THD+N is 0.03% or less, and then checks the THD+N accuracy of the audio option by reading a known signal.

Specification Checked

THD+N accuracy is $\pm 10\%$ of the reading ± 1 digit for harmonics at input levels of -20 dBu or greater in a 33 Hz to 22 kHz bandwidth.

Option 40 Distortion Measurement Accuracy

1. Check residual THD+N.
 - a. Apply a signal (between -20 dBu and $+30$ dBu) from a sine-wave generator to the VM700T Audio Option 40. See Figure 4-7 for a cabling diagram. The generator should be set at 50Ω output resistance.

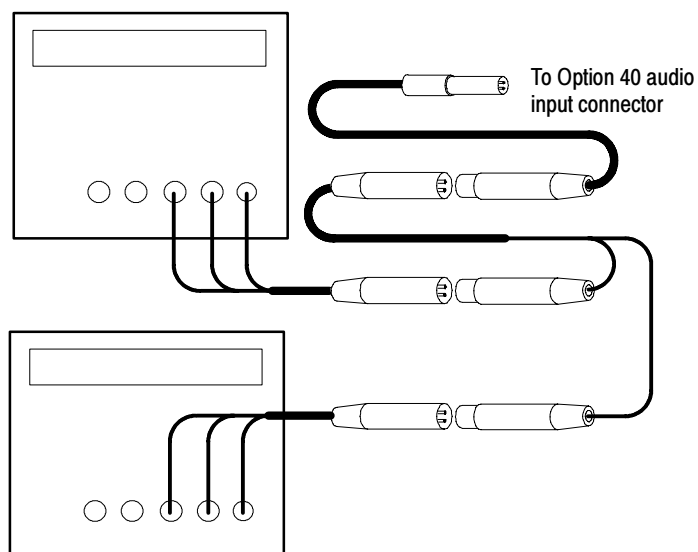

Figure 4-7: Option 40 cable connections, distortion measurement accuracy check

- b. Run the Audio Analyzer measurement and verify that residual THD+N is 0.03% or less. An applied signal of $+8$ dBu to $+10$ dBu yields an optimal reading, while a -20 dBu signal yields a worst-case reading.

2. Check THD+N Measurement Accuracy.
 - a. With 600 Ω output resistance selected, connect the outputs of two sine-wave generators in parallel to the left channel input of the Audio Option. See Figure 4-7 for a cabling diagram.
 - b. Set one sine-wave generator for a 2 V_{RMS} output at 1 kHz and set the second sine-wave generator for a 0.02 V (20 mV_{RMS}) at 3 kHz. These two signals add across the termination resistance to produce a 1 kHz signal with a 1% third-harmonic distortion.
 - c. Run the Audio Analyzer measurement and check for a THD+N reading of 0.9% to 1.1%.
3. Move the input from the generators to the right channel and repeat step 2, part d.

Check Frequency and Phase Measurement Accuracy

This procedure requires an accurate frequency sine-wave generator or a digital counter to accurately set the frequency. The phase measurement requires that both channels have the same signal applied through equal length cables.

Specifications Checked

This procedure checks the following parameters:

- Frequency accuracy: ± 1 Hz (or $\pm 0.01\%$ + 1 digit, whichever is worse) for inputs of -60 dBu or greater in the frequency range of 20 Hz to 20 kHz.
- Channel phase difference: $\pm 1^\circ$ for inputs of 40 Hz to 20 kHz, $\pm 2^\circ$ for inputs of 20 Hz to 40 Hz at a level of -40 dBu or greater.

Option 40 Frequency Accuracy and Channel Phase Difference

1. Connect the sine-wave generator output to both the left and right inputs of the Audio board (see Figure 4-6).
2. Set the sine-wave generator for a frequency and amplitude in the specified frequency and amplitude range of the Audio option (20 Hz to 20 kHz, amplitude of -60 dBu or greater).

NOTE. Use a test signal level of at least -60 dBu and test at least 10 frequencies over the entire range. Tested frequencies should include the specification limits (20 Hz, 20 kHz) and the 40 Hz breakpoint. Example frequencies to test might also include the following: 100 Hz, 200 Hz, 1 kHz, 2 kHz, 10 kHz.

3. Check that the measured frequency is accurate to the limits shown in Table 4-3 for the applied test signal frequency and level. Check that the phase difference between channels meets the phase difference specification.

Audio Option 41 Triple-Input Verification Procedure

This section describes the differences in operation between Option 40 and Option 41, and it gives the verification procedure for Option 41.

Configuring Source Selection Audio

The Option 41 software is similar to the Option 40 software except for the Source Selection Audio file.

The Source Selection Audio file lets you specify an Option 41 audio input (1, 2, 3) for a video source (A, B, C), and then select an appropriate audio source file (if you want to use an audio source file other than the system default).

In the next steps you want to have source A to audio input 1, source B to 2, and source C to 3.

To specify audio inputs and audio source files for video sources, use the following procedure:

1. From Measure Mode, press the Configure front-panel button, touch the Configure Files soft key followed by the Source_Selection Audio soft key.
2. Rotate the front panel knob to highlight the source (A, B, C) for which you are specifying an audio input and an audio source file.
3. Touch the highlighted audio input (1, 2, or 3) to select it.
4. Rotate the front-panel knob to change the audio input selection.
5. Touch the highlighted source file to select it.
6. Rotate the front-panel knob to change the audio source file selection (if you are using an audio source file other than the system default).
7. When you have specified the audio inputs and source files, touch the Accept Input soft key.
8. If the change is correct, touch the Update & Exit soft key, otherwise, touch the No Change & Exit soft key.

NOTE. If you change audio input and source files and then decide to exit the directory and cancel the change, you must press the Accept Input soft key, followed by the No Change & Exit soft key. The measurement verifies that you want to exit the Source Selection Audio directory and cancel any changes by asking you to touch the No Change & Exit soft key again.

Check Level Measurement Accuracy and Flatness

This procedure verifies flatness and measurement accuracy by checking signal levels at specified frequencies.

NOTE. Frequencies and levels checked are not specified in this procedure. If the measurement accuracy of certain frequencies and levels is important to your application, we recommend that your test procedure include those frequencies and levels.

Specifications Checked

Table 4-5 lists audio option accuracy and flatness specifications.

Table 4-5: Accuracy and flatness specifications

Frequency Range	Level Range ¹	Accuracy (includes flatness)	Flatness
20 - 40 Hz	≥ -20 dBu	+ 0.3 / - 0.2 dB	+ 0.1 / - 0.2 dB
	- 20 dBu to - 50 dBu	+ 0.4 / - 0.3 dB	+ 0.1 / - 0.2 dB
	- 50 dBu to - 60 dBu	+ 0.6 / - 0.5 dB	+ 0.2 / - 0.3 dB
	- 60 dBu to - 70 dBu	± 1.0 dB	+ 0.4 / - 0.5 dB
40 Hz - 20 kHz	≥ -20 dBu	± 0.2 dB	± 0.1 dB
	- 20 dBu to - 50 dBu	± 0.3 dB	± 0.1 dB
	- 50 dBu to - 60 dBu	± 0.5 dB	± 0.2 dB
	- 60 dBu to - 70 dBu	± 1.0 dB	± 0.4 dB

¹ Level difference between channels is ±0.2 dB at levels of -50 dBu and greater.

Option 41 Level Accuracy and Flatness

1. Power on the VM700T and associated test equipment and let them warm up for 20 minutes.
2. Connect the sine-wave generator to the Option 41 audio input connector as in Figure 4-8.
3. Press the Measure hard key, select Audio, and run the audio analyzer measurement.

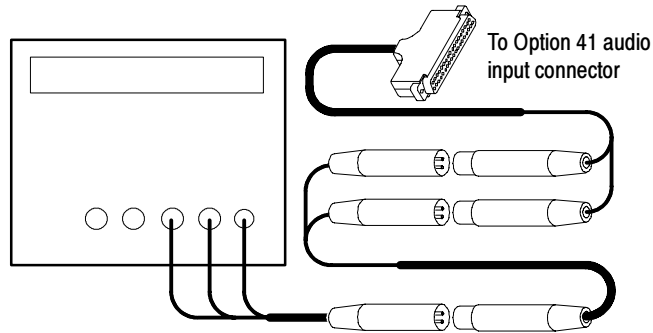

Figure 4-8: Option 41 cable connections, level accuracy and flatness check

4. Using a known accurate sine-wave generator (or one verified with an accurate AC voltmeter), apply a 120 Hz input to the Audio option at amplitudes ≥ -20 dBu (for example, +18, +8, -2, and -12 dBu) and verify that the level accuracy is ± 0.1 dB.
5. Select at least 6 frequencies and 10 amplitudes to test. The frequencies and amplitudes you select must be in the ranges listed in Table 4-5 (use a signal amplitude level of -70 dBu to test for worst case). Table 4-6 shows an example selection of test frequencies and amplitudes.
6. Set the sine-wave generator for each of the selected frequencies and amplitudes.
 - a. Record the level of each frequency.
 - b. Verify that the measured levels recorded for each frequency are within the flatness specification given in Table 4-3 on page 4-15.

Table 4-6: Example test signals for level and flatness test

Frequency	Amplitudes
30 Hz	-10 dBu, -21 dBu, -40 dBu, -49 dBu,
100 Hz	-51 dBu, -55 dBu, -59 dBu,
1 kHz	-61 dBu, -65 dBu, -70 dBu
5 kHz	
12 kHz	
20 kHz	

7. Repeat step 5 for channels B and C.

Check Distortion and Distortion Measurement Accuracy

This procedure verifies that residual THD+N is $\leq 0.03\%$, then checks the THD+N measurement accuracy by reading a known signal.

Specification Checked

THD+N accuracy is $\pm 10\%$ of the reading ± 1 digit for harmonics at input levels of -20 dBu and greater in a 33 Hz to 22 kHz bandwidth.

Option 41 Distortion Measurement Accuracy

1. Check residual THD+N.
 - a. Apply a signal (between -20 dBu and $+30$ dBu) from a sine-wave generator to the VM700T Audio Option. See to Figure 4-9 for connections.
 - b. Run the Audio Analyzer measurement and verify that residual THD+N is 0.03% or less. An applied signal of $+8$ to $+10$ dBu yields an optimal reading, while a -20 dBu signal yields a worst-case reading.
2. Check THD+N Measurement Accuracy.
 - a. With 600Ω output resistance selected, connect the outputs of two sine-wave generators in parallel to the left channel of the dual female XLR to DB-37 female adapter cable (see Figure 4-9).

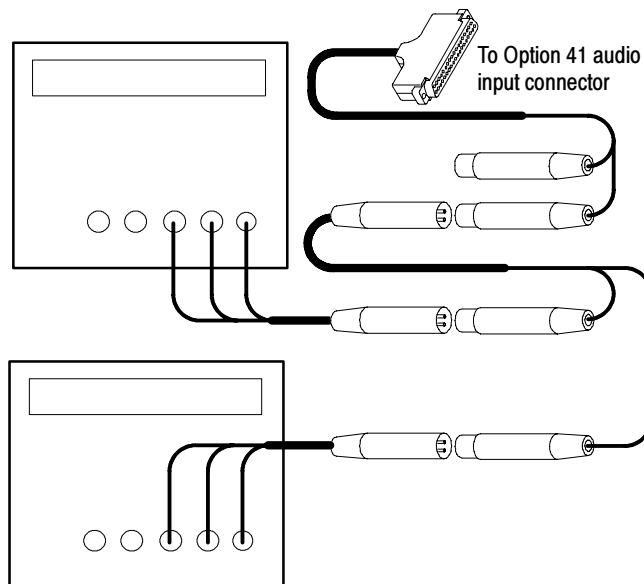

Figure 4-9: Option 41 cable connections, distortion measurement accuracy check

- b. Set one sine-wave generator for a 2 V rms output at 1 kHz.

- c. Set the second sine-wave generator for a 0.02 V (20 mV rms) at 3 kHz. These two signals add across the termination resistance to produce a 1 kHz signal with a 1% third-harmonic distortion.
 - d. Run the Audio Analyzer measurement and check for a THD+N reading of 0.9% to 1.1%.
 - e. Move the generator signals to the right channel input and repeat step 2, part d.
3. Repeat step 2 for channels B and C; substitute the appropriate channel when channel A is called for.

Check Frequency and Phase Measurement Accuracy

This procedure requires an accurate frequency generator or a digital counter to set the frequency. The phase measurement requires that both channels have the same signal applied.

Specifications Checked

This procedure checks the following parameters:

- Frequency accuracy: ± 1 Hz (or $\pm 0.01\%$ + 1 digit, whichever is worse) for inputs of -60 dBu and greater in the frequency range of 20 Hz to 20 kHz.
- Channel phase difference: $\pm 1^\circ$ for inputs of 40 Hz to 20 kHz, $\pm 2^\circ$ for inputs of 20 Hz to 40 Hz at levels of -40 dBu and greater.

Option 41 Frequency Accuracy and Channel Phase Difference

1. As in Figure 4-9, connect the sine-wave generator output to the Audio board.
2. Set the sine-wave generator for a frequency and amplitude in the specified frequency and amplitude range of the Audio option (20 Hz to 20 kHz, amplitude of -60 dBu or greater).

NOTE. Use a test signal level of at least -60 dBu and test at least 10 frequencies over the entire range. Tested frequencies should include the specification limits (20 Hz, 20 kHz) and the 40 Hz breakpoint. Example frequencies to test might also include the following: 100 Hz, 200 Hz, 1 kHz, 2 kHz, 10 kHz.

3. Check that the measured frequency is accurate to the limits shown in Table 4-5 for the applied test signal frequency and level, and that the phase difference between channels meets the phase difference specification.

SDI Option 1S Performance Verification

This section contains the performance verification procedure for Option 1S.

The test equipment required to perform the Option 1S verification procedures is listed in Table 4-7. Test equipment examples are based on the test equipment that many customers and the Tektronix service centers have installed for supporting the VM700 family of video measurement sets. Substitute test equipment meeting the minimum specifications may be used if available.

Table 4-7: Test equipment required for Option 1S verification

Test equipment	Minimum specification	Purpose	Example
Leveled sine-wave generator	Output source resistance: $50\ \Omega \pm 1\%$; Amplitude accuracy at 67.5 MHz: $\pm 3\%$; Amplitude flatness at 550 MHz: $\pm 4\%$ of 50 kHz reference	Checking Eye Diagram amplitude accuracy and frequency response	Tektronix SG5030 ¹
Digital television signal generator	SMPTE 259M SDI signals: 270 Mb, 525-line, 100% color bars; 143 Mb 525-line, NTC7 combination; 360 Mb, 525-line, 10 step SDI signal jitter: Amplitude range of 0 to 15 ns, $\pm 10\%$ at 2 ns; Frequency range of 50 Hz to 10 MHz Variable vertical signal timing of ± 262 lines	Serial digital television test signal source	Tektronix TG2000 Signal Generation Platform; DVG1 generator module with Option S1
Television signal generator	Nominal NTSC video signal synchronized with a serial digital test signal	Analog television signal source	Tektronix TG 2000 Signal Generation Platform; BG1 module
Coaxial cable, BNC connectors	(3) $75\ \Omega$ impedance, Belden 8281; 1-meter length	Signal interconnections	Tektronix part number 012-0159-00
Terminations	$75\ \Omega$ precision high-frequency (26 dB to 300 MHz); BNC connectors	Signal termination	Tektronix part number 011-0163-00
	$50\ \Omega$ precision, SMA connectors	Signal termination	Tektronix part number 015-1022-00
	$50\ \Omega$ feedthrough, BNC connectors	Checking the Analog Ref input	Tektronix part number 011-0049-01
	(2) $75\ \Omega$ feedthrough, BNC connectors	Checking the Analog Ref input	Tektronix part number 011-0055-01
SMA to BNC adapter	SMA female to BNC male		Tektronix part number 015-0572-00
$50\ \Omega$ / $75\ \Omega$ converter	$50\ \Omega$ BNC female to $75\ \Omega$ BNC male		Tektronix part number 011-0057-01

¹ The example leveled sine wave generator requires a TEGAM TM500 or TM5000 series power module.

Preliminary Setup

Perform the following steps to setup the equipment for the Option 1S performance verification:

1. Connect power to the VM700T and turn the instrument on. Verify that the instrument passes all diagnostics as the instrument powers up.
2. Press the VM700T front-panel Configure button. Select Mode: Digital if necessary using the Mode soft key.

NOTE. *The VM700T must be set to Mode: Digital before you can perform the Option 1S performance verification procedures.*

3. Touch the Configure Files soft key, and then touch the Source_Selection Digital soft key.
4. Highlight the Digital A: line using the front-panel knob, and then touch the highlighted line to cause a box to appear around the current selection.
5. Turn the knob to select Auto Detect, and then touch the Accept Input soft key.
6. Highlight the Digital B: line using the knob, and then touch the highlighted line to cause a box to appear around the current selection.
7. Turn the knob to select Auto Detect, touch the Accept Input soft key, and then touch the Update & Exit soft key to exit the configuration file.

NOTE. *The VM700T and Option 1S must be warmed up for at least 20 minutes before you perform the Option 1S performance verification procedures.*

SDI Analog Ref Input

The amplitude range specification for the SDI Analog Ref input is ± 6 dB with respect to $1 V_{pp}$ video. Perform the following procedure to check the amplitude range of the SDI Analog Ref input:

1. Connect an NTSC black burst signal to the Option 1S Analog Ref input. Terminate the signal using two 75Ω feedthrough terminators in series with one 50Ω feedthrough terminator (provides a $0.5 V_{pp}$ signal).
2. Connect a 270 Mb, 525-line, 100% color bars signal to the Option 1S SDI Ch. A input. Terminate the SDI Ch. A input using a 75Ω high-frequency terminator.
3. Set the digital television signal generator for a vertical delay of 262 lines on the 100% color bar signal.
4. Press the Source A button to select channel A for display, and then press the VM700T front-panel Measure button.
5. Touch the SDI_IC_Timing soft key. Press the front-panel Menu button, and then touch the Relative Analog soft key.
6. Check the measurement reading:
 - VM700T firmware version 980422 and below: 16 mSec to 17 mSec.
 - VM700T firmware version 990512 and above: - 16 mSec to - 17 mSec.
7. Remove the three terminators from the signal on the Analog Ref input.
8. Check the measurement reading:
 - VM700T firmware version 980422 and below: 16 mSec to 17 mSec.
 - VM700T firmware version 990512 and above: -16 mSec to -17 mSec.

Eye Diagram Application

Perform the following procedures to check the SDI Eye Diagram application.

Eye Diagram Amplitude Accuracy

The amplitude accuracy specification for the SDI Eye Diagram application is $\pm 5\%$ for signals between 600 mV_{pp} and 1 V_{pp} . Perform the following procedure to check the amplitude accuracy of the SDI Eye Diagram application.

1. Connect a 67.5 MHz, 800 mV_{pp} leveled sine wave to the SDI Ch. A input. Terminate the SDI Ch. A input with a 50Ω precision terminator.

NOTE. *If you are using the Tektronix SG 5030, connect the Output Head directly to the SDI Ch. A input (no cable between the Output Head and the input).*

2. Press the VM700T front-panel Measure button, and then touch the SDI_Eye Diagram soft key.
3. Press the VM700T front-panel Menu button.
4. Touch the Waveform soft key, and then select Free Run on (soft key is highlighted).
5. Press the VM700T front-panel Menu button, and then touch the Cursors/Units softkey.
6. Touch the Volt Cursor 1 soft key, and then use the front-panel knob to position the cursor to the top of the sine wave.

NOTE. *It may be necessary to expand the waveform to accurately position the voltage cursors. You can expand the waveform by touching the waveform and then using the front-panel knob to adjust the waveform display.*

7. Touch the Volt Cursor 2 soft key, and then use the front-panel knob to position the cursor to the bottom of the sine wave.
8. Check that the V1 - V2 measurement readout is 770 mV to 820 mV ($800 \text{ mV} \pm 3.8\%$).

Eye Diagram Frequency Response

The frequency response (20% to 80% rise time) specification for the SDI Eye Diagram application is ± 100 ps for rise times between 400 ps and 1.5 ns. Perform the following procedure to check the frequency response of the SDI Eye Diagram application.

1. Connect a 50 kHz, 1.25 V_{pp} leveled sine wave through a 50 Ω /75 Ω converter to the SDI Ch. A input. Terminate the SDI Ch. A input with a 75 Ω high-frequency terminator.

NOTE. *If you are using the Tektronix SG 5030, connect the 50 Ω /75 Ω converter between the Output Head and the SDI Ch. A input (no cable between the Output Head and the input).*

2. Press the VM700T front-panel Measure button, and then touch the SDI_Eye Diagram soft key.
3. Press the VM700T front-panel Menu button. Touch the Waveform soft key, and then select Free Run on (soft key is highlighted).
4. Press the VM700T front-panel Menu button, and then touch the Cursors/Units softkey.
5. Touch the Volt Cursor 1 soft key, and then use the front-panel knob to position the cursor to 400 mV as read in the readout.
6. Touch the Volt Cursor 2 soft key, and then use the front-panel knob to position the cursor to -400 mV as read in the readout.
7. Adjust the amplitude of the leveled sine wave so that the displayed waveform amplitude matches the voltage cursors.

NOTE. *It may be necessary to expand the waveform to accurately position the voltage cursors. You can expand the waveform by touching the waveform and then using the front-panel knob to adjust the waveform display. If there is a small DC offset, adjust for equal error at the two cursors so that waveform amplitude is 800 mV.*

8. Set the frequency of the leveled sine wave to 550 MHz without adjusting the signal amplitude.
9. Touch the Volt Cursor 1 soft key, and then use the front-panel knob to position the cursor to the top of the sine wave.
10. Touch the Volt Cursor 2 soft key, and then use the front-panel knob to position the cursor to the bottom of the sine wave.
11. Check that the waveform amplitude readout (V1-V2) is 520 mV to 721 mV (65% to 90%).

Jitter Application

The following Jitter application checks verify the frequency response of the Timing Jitter and Alignment Jitter measurements. They also verify the Jitter Waveform and Jitter Spectrum displays including the 10 Hz and 1 kHz filters in both Line and Frame modes.

NOTE. *In the following steps you will check the readout of the Jitter timing (p-p) and Jitter Alignment (p-p) measurements. Use the value which appears most frequently. If two values appear with equal frequency, use the larger value.*

If you are using a Tektronix TG2000 Signal Generation Platform with a DVG1 module, you must use Output 2 on the DVG1 to perform this check.

1. Perform the following steps to check the Jitter application at 270 Mb and 50 Hz:
 - a. Connect a 270 Mb, 525-line, 100% color bars signal to the SDI Ch. A input. Terminate the SDI Ch. A input loophrough using a 75 Ω high-frequency terminator.
 - b. Adjust the digital television signal generator for a jitter frequency of 50 Hz and a jitter amplitude of 2 ns on the signal output.
 - c. Press the VM700T front-panel Measure button, and then touch the SDI_Jitter soft key.
 - d. Press the VM700T front-panel Menu button.
 - e. Select Rate: Frame if necessary using the Rate soft key.
 - f. Select Filter: 10 Hz if necessary using the Filter soft key.
 - g. Touch the Cursors/Units soft key.
 - h. Touch the Spectrum Cursor 1 soft key, and then use the front-panel knob to position the cursor to 50 Hz as read in the readout.
 - i. Check that the Spectrum Cursor 1 amplitude readout is -2.4 to -8.4 dB.
 - j. Check that the Timing (p-p) readout is 1600 to 2600 ps.

2. Perform the following steps to check the Jitter application at 270 Mb and 580 Hz:
 - a. Adjust the digital television signal generator for a jitter frequency of 580 Hz and a jitter amplitude of 2 ns on the signal output.
 - b. Press the VM700T front-panel Menu button.
 - c. Select Filter: 1 kHz using the Filter soft key.
 - d. Touch the Rescale soft key, and then touch the Cursors/Units soft key.
 - e. Touch the Spectrum Cursor 1 soft key, and then use the front-panel knob to position the cursor to 580 Hz as read in the readout.
 - f. Check that the Spectrum Cursor 1 amplitude readout is -7.4 to -15.4 dB.
 - g. Check that the Timing (p-p) readout is 1600 to 2600 ps.
 - h. Check that the Alignment (p-p) readout is 700 to 1500 ps.
3. Perform the following steps to check the Jitter application at 270 Mb and 15 kHz:
 - a. Adjust the digital television signal generator for a jitter frequency of 15 kHz and a jitter amplitude of 2 ns on the signal output.
 - b. Touch the Rescale soft key, and then touch the Cursors/Units soft key.
 - c. Touch the Spectrum Cursor 1 soft key, and then use the front-panel knob to position the cursor to 15 kHz as read in the readout.
 - d. Check that the Spectrum Cursor 1 amplitude readout is -2.4 to -8.4 dB.
 - e. Press the VM700T front-panel Menu button.
 - f. Select Rate: Line using the Rate soft key.
 - g. Touch the Cursors/Units soft key.
 - h. Touch the Spectrum Cursor 1 soft key, and then use the front-panel knob to position the cursor to 15 kHz as read in the readout.
 - i. Check that the Spectrum Cursor 1 amplitude readout is -2.4 to -8.4 dB.
 - j. Check that the Timing (p-p) readout is 1600 to 2600 ps.
 - k. Check that the Alignment (p-p) readout is 1600 to 2600 ps.

4. Perform the following steps to check the Jitter application at 270 Mb and 0.5 MHz:
 - a. Adjust the digital television signal generator for a jitter frequency of 0.5 MHz and a jitter amplitude of 1 ns on the signal output.
 - b. Touch the Spectrum Cursor 1 soft key, and then use the front-panel knob to position the cursor to 0.5 MHz as read in the readout.
 - c. Check that the Spectrum Cursor 1 amplitude readout is -8.4 to -14.4 dB.
 - d. Check that the Timing (p-p) readout is 800 to 1400 ps.
 - e. Check that the Alignment (p-p) readout is 800 to 1400 ps.
5. Perform the following steps to check the Jitter application at 270 Mb and 5 MHz:
 - a. Adjust the digital television signal generator for a jitter frequency of 5 MHz and a jitter amplitude of 1 ns on the signal output.
 - b. Press the VM700T front-panel Menu button.
 - c. Touch the Rescale soft key, and then touch the Cursors/Units soft key.
 - d. Touch the Spectrum Cursor 1 soft key, and then use the front-panel knob to position the cursor to 5 MHz as read in the readout.
 - e. Check that the Spectrum Cursor 1 amplitude readout is -8.4 to -14.4 dB.
 - f. Check that the Timing (p-p) readout is 700 to 1800 ps.
 - g. Check that the Alignment (p-p) readout is 700 to 1800 ps.
6. Perform the following steps to check the Jitter application at 270 Mb and 9.9 MHz:
 - a. Adjust the digital television signal generator for a jitter frequency of 9.9 MHz and a jitter amplitude of 1 ns on the signal output.
 - b. Press the VM700T front-panel Menu button.
 - c. Touch the Cursors/Units soft key.
 - d. Touch the Spectrum Cursor 1 soft key, and then use the front-panel knob to position the cursor to 9.9 MHz as read in the readout.
 - e. Check that the Spectrum Cursor 1 amplitude readout is -8.4 to -17.4 dB.
 - f. Check that the Timing (p-p) readout is 700 to 1800 ps.
 - g. Check that the Alignment (p-p) readout is 700 to 1800 ps.

7. Perform the following steps to check the Jitter application at 143 Mb and 3 MHz:
 - a. Replace the 270 Mb signal on the SDI Ch. A input with a 143 Mb, 525-line, NTC7 combination signal. Leave the SDI Ch. A input terminated with the high-frequency terminator.
 - b. Adjust the digital television signal generator for a jitter frequency of 3 MHz and a jitter amplitude of 1 ns on the signal output.
 - c. Touch the Spectrum Cursor 1 soft key, and then use the front-panel knob to position the cursor to 3 MHz as read in the readout.
 - d. Check that the Spectrum Cursor 1 amplitude readout is -14 to -22 dB.
 - e. Check that the Timing (p-p) readout is 700 to 1400 ps.
 - f. Check that the Alignment (p-p) readout is 700 to 1400 ps.
8. Perform the following steps to check the Jitter application at 360 Mb and 15 kHz:
 - a. Replace the 143 Mb signal on the SDI Ch. A input with a 360 Mb, 525-line, 10 step signal. Leave the SDI Ch. A input terminated with the high-frequency terminator.
 - b. Adjust the digital television signal generator for a jitter frequency of 15 kHz and a jitter amplitude of 2 ns on the signal output.
 - c. Check that the Timing (p-p) readout is 1600 to 2600 ps.
 - d. Check that the Alignment (p-p) readout is 1600 to 2600 ps.
9. Perform the following steps to check the Jitter application at 360 Mb and 9.9 MHz:
 - a. Adjust the digital television signal generator for a jitter frequency of 9.9 MHz and a jitter amplitude of 0.7 ns on the signal output.
 - b. Touch the Spectrum Cursor 1 soft key, and then use the front-panel knob to position the cursor to 9.9 MHz as read in the readout.
 - c. Check that the Spectrum Cursor 1 amplitude readout is -9 to -18 dB.
 - d. Check that the Timing (p-p) readout is 490 to 1320 ps.
 - e. Check that the Alignment (p-p) readout is 490 to 1320 ps.

Interchannel Timing Application

Perform the following procedure to check the SDI Interchannel Timing application.

1. Perform the following steps to check the digital-to-analog mode of the SDI Interchannel Timing application:

NOTE. *The measurement reading you make in step e of this procedure assumes you are using the Tektronix TG2000 Signal Generation Platform for this check. For VM700T firmware version 980422 and below, there is a built-in timing offset of 224.4 μ sec. For VM700T firmware version 990512 and above, there is a built-in timing offset of 2.0 μ sec.*

- a. Connect an NTSC black burst signal to the Option 1S Analog Ref input. Terminate the Analog Ref loopthrough using a 75 Ω terminator.
 - b. Replace the 360 Mb signal on the SDI Ch. A input with a 270 Mb, 525-line, 100% color bars signal. Leave the SDI Ch. A input terminated with the high-frequency terminator.
 - c. Press the VM700T front-panel Measure button, and then touch the SDI_IC_Timing soft key.
 - d. Press the front-panel Menu button, and then touch the Relative Analog soft key.
 - e. Check the interchannel timing measurement reading:
 - VM700T firmware version 980422 and below: -224.0 to -224.8 μ s.
 - VM700T firmware version 990512 and above: -1.6 to -2.4 μ s.
2. Perform the following steps to check the digital-to-digital mode of the SDI Interchannel Timing application:
 - a. Remove the signal cable and terminator from the Option 1S Analog Ref input, and then remove the terminator from the SDI Ch. A input loopthrough.
 - b. Connect a one meter cable from the SDI Ch. A input loopthrough to the SDI Ch. B input.
 - c. Touch the Relative Digital soft key.
 - d. Check for an interchannel timing measurement reading of ± 37 ns.
 - e. Remove all cable and terminators from the VM700T.

SDI Output

Perform the following procedure to check the SDI Output signal.

1. Connect a 270 Mb, 525-line, 100% color bars signal to the SDI Ch. B input.
2. Connect a one meter cable from the SDI Output to the SDI Ch. A input. Terminate the SDI Ch. A input using a 75 Ω high-frequency terminator.
3. Press the VM700T front-panel Configure button.
4. Touch the Configure Files soft key, and then touch the Source_Selection Digital soft key.
5. Highlight the SDI Output line using the front-panel knob, and then touch the highlighted line to cause a box to appear around the current selection.
6. Turn the knob to select Channel B, and then touch the Accept Input soft key. Touch the Update & Exit soft key to exit the configuration file.
7. Press the front-panel Measure button, and then touch the SDI_EyeDiagram soft key.
8. Press the front-panel Menu button, and then touch the Measure soft key.
9. Touch the following soft keys if necessary to turn the measurements on (soft keys will be highlighted): Meas. Box, Eye Amplitude, Rise\Fall Times, and Rise Time Adjusted.

NOTE. For the SDI Output check, the Average function must be turned off. Use the front-panel Average button to turn off the Average function.

10. Check that the Amplitude readout is 720 mVolts to 880 mVolts.
11. Check that Risetime and Falltime readouts are both 400 pSec to 800 pSec.
12. Remove all cable and terminators from the VM700T.

Adjustment Procedure

The procedures in this section may be used if performing the Verification procedures determines readjustment is needed. Additionally, after a board exchange, certain adjustments may be needed to compensate the overall system performance. Follow the directions found in the adjustment procedures when readjustment is needed.

Test Equipment Required

The test equipment to use for performing the system level adjustment procedures is shown in Table 5-1. Test equipment suggestions for use in doing the verification procedure are given in the example column. The examples given are based on the test equipment that many customers and the Tektronix service centers have installed for supporting the VM700 family of video measurement sets. Substitute test equipment may be used if available. Refer to the Minimum Specification column to determine the key specifications needed to verify the accuracy of the VM700T Video Measurement Set.

The specific pieces of equipment required to perform a procedure are shown at the beginning of that procedure. Note that the Gain-Phase analyzer is required for the extended adjustment procedure only.

Table 5-1: Test equipment required for verification and adjustment

Equipment	Minimum specification	Purpose	Example
Video amplitude calibrator	Square wave 0.0 mV to 999.9 mV peak; accuracy 0.05%, resolution 0.1 mV	Reference standard for amplitude verification	Tektronix 067-0916-00 (not currently available for purchase) ¹
Leveled sine-wave generator	75 Ω output impedance; output flat within ± 0.025 dB ($\approx 0.3\%$) to 6 MHz	Measure sine wave, filter flatness adjustment	Hewlett-Packard 3336C Sine-wave generator with option 005 ²
Television signal generator	NTSC, full field and burst capability, accurate to ± 1 Hz	NTSC test signal source	Tektronix TSG-170A or equivalent
Television signal generator	PAL, full field and burst capability, accurate to ± 1 Hz	PAL test signal source	Tektronix TSG-271 or equivalent
Frequency counter	External reference capability or ratio A/B, 8-digit display	Adjust the GenLock VCO	Tektronix DC 503A, TEGAM DC 503A, or equivalent
Digital multimeter	DC Volts range, 20 mV to 200 V; 3-1/2-digit display	Adjust the GenLock VCO, adjust CalDac	Tektronix DM 502A or equivalent

Table 5-1: Test equipment required for verification and adjustment (cont.)

Equipment	Minimum specification	Purpose	Example
Coaxial cable, 2 required	75 Ω impedance, high-quality noise free; 1-meter length	Signal interconnections	Tektronix part number 012-0074-00
Termination	75 Ω precision, BNC connectors	Signal termination	Tektronix part number 011-0102-01
Alignment tool	Non-metallic, flat-blade	Adjust potentiometers and capacitors	Tektronix part number 003-1364-00
Screwdrivers	Pozidriv 1X and 2X	Remove and replace cover panel screws	
Gain-phase analyzer	75 Ω impedance	Extended flatness adjustment	Hewlett-Packard 4194A Impedance/Gain-Phase analyzer
Feed-through termination	75 Ω impedance, BNC connectors	Signal termination	Tektronix part number 011-0055-01
Adapter, 2 required	BNC female to SMB male snap-on connector	Signal interconnections for extended flatness adjustment	Omni/Spectra part number 3280-2224-00 ³

- ¹ The example amplitude calibrator requires a TEGAM TM500 or TM5000 series power module.
- ² The flatness accuracy required of the leveled sine-wave generator is only to the bandwidth needed to perform the VM700T verification and adjustments. It is not specified to be that flat over the entire bandwidth of the generator.
- ³ Omni/Spectra is a MACOM company: 140 Fourth Avenue, Waltham, MA 02254, USA or 77 Milford Road, Reading, Berks., RG1 8LG, England. The example connector is a distributor part.

System Adjustment Procedures

NOTE. This equipment requires a 20 minute warm-up period before starting the verification procedures. The instrument must be powered on for at least 20 minutes.

After a board replacement, certain adjustments may be needed to compensate the overall system performance. The procedures in this section may be used to make those adjustments.

NOTE. These procedures are not complete board level adjustments. Most of the factory adjustments are made during testing before the boards are assembled into the VM700T. The adjustments given here are those used to verify and adjust the instrument at the system level.

Adjust the Genlock Voltage-Controlled Oscillator (VCO)

This procedure verifies the VM700T genlock VCO by comparing it to a frequency standard and describes the adjustment process if that is needed.

Test Equipment Required

- Signal generator. Tektronix TSG-170A or equivalent for NTSC or Tektronix TSG-271 or equivalent for PAL. Both signal generators are needed for dual-standard instruments.
- Frequency counter with external reference or Ratio A/B. Tektronix DC 503A, TEGAM DC 503A, or equivalent.
- Digital voltmeter with 3-1/2-digit display.
- Termination, 75 Ω precision BNC. Tektronix 011-0102-01.
- Coaxial cables, 75 Ω high-quality, noise free BNC; 1-meter length, 2 each. Tektronix 012-0074-00.
- Non-metallic, flat-blade adjusting tool. Tektronix 003-1364-00.

NOTE. *This procedure requires access to a radio-frequency standard signal. If you do not have access to a radio-frequency standard signal, do not attempt to adjust the frequency of the VM700T genlock crystal oscillator.*

Specification Checked

Genlock VCO: within ± 5 Hz of a radio-frequency standard 1 MHz signal when checked with the following procedure. Single standard instruments, either NTSC or PAL, need only one VCO checked. For dual-standard instruments, both the PAL and the NTSC VCO must be checked.

Verifying the Genlock Voltage-Controlled Oscillator

1. Connect a radio-frequency standard 1 MHz signal to the external reference input of the frequency counter (channel B of the example counter).
2. Connect the subcarrier output of the appropriate video signal generator (NTSC or PAL) to the signal input of the frequency counter (channel A of the example counter).
3. Using the suggested frequency counter, the ratio of the channel A to channel B signal is used to determine when the frequency of the test signal is adjusted correctly. Adjust the signal generator until the frequency counter displays the exact TV standard subcarrier frequency for the VCO being checked (3.579545 MHz for NTSC or 4.43361875 for PAL).
4. Connect the composite video output of the signal generator to the VM700T channel A input (terminate channel A with the 75 Ω termination).

5. With the VM700T powered off, remove the three top cover holding screws (found at the rear of the instrument) and slide the top cover panel back enough to expose the genlock board (just behind the CRT module). Power on the instrument and allow it to warm for 20 minutes if not already warmed up.
6. For dual-standard instruments, select either NTSC or PAL mode, as needed for the VCO being checked. This may be done by pressing the Measure hard key then the Video~Standard soft key to identify the applied composite video signal source. Then press the Waveform hard key to return to the Waveform mode. Selecting the TV standard in this manner is temporary, and the configuration returns to match that set in the Video Source file at the next power on. Alternately, you may use the Configure menus to set the Video Source file for the TV standard you have applied to the channel.
7. Connect the DVM plus lead to TP 86 on the Genlock board and the minus lead to chassis ground. Check that the voltage is about 0 V ($0\text{ V} \pm 250\text{ mV}$). The VM700T must be locked to the external input signal.

NOTE. *If the VM700T meets the limits described, skip step 8 and go to step 9. Adjusting the VM700T unnecessarily (for example, to get a “better” reading on a calibration result that is within limits) can introduce errors into a functional instrument.*

8. Adjust the VCO adjusting screw for the TV standard you are checking (either NTSC or PAL) for a DVM reading as close as possible to 0 V ($0\text{ V} \pm 250\text{ mV}$ or better). The VCOs are located in metal housings on the Genlock board near the back of the Display Monitor (CRT) (see Figure 5-1).

NOTE. *If your instrument is a dual standard instrument, check both VCOs before continuing with step 9.*

9. Disconnect the DVM from the VM700T and reinstall the instrument covers.
10. Disconnect all signal inputs from the VM700T, then wait 5 minutes while the internal temperature of the instrument stabilizes.
11. Press the Measure hard key and touch the Video soft key, if necessary, to recall the Video measurement menu.
12. Touch the Burst Frequency soft key. With no signal applied, the VM700T displays a warning message that tells you to check the signal source because a signal cannot be found. The burst frequency measurement starts automatically after 3 seconds (the Loss of Sync indicator blinks).
13. Press the Menu hard key and touch the Reference soft key in the menu display.

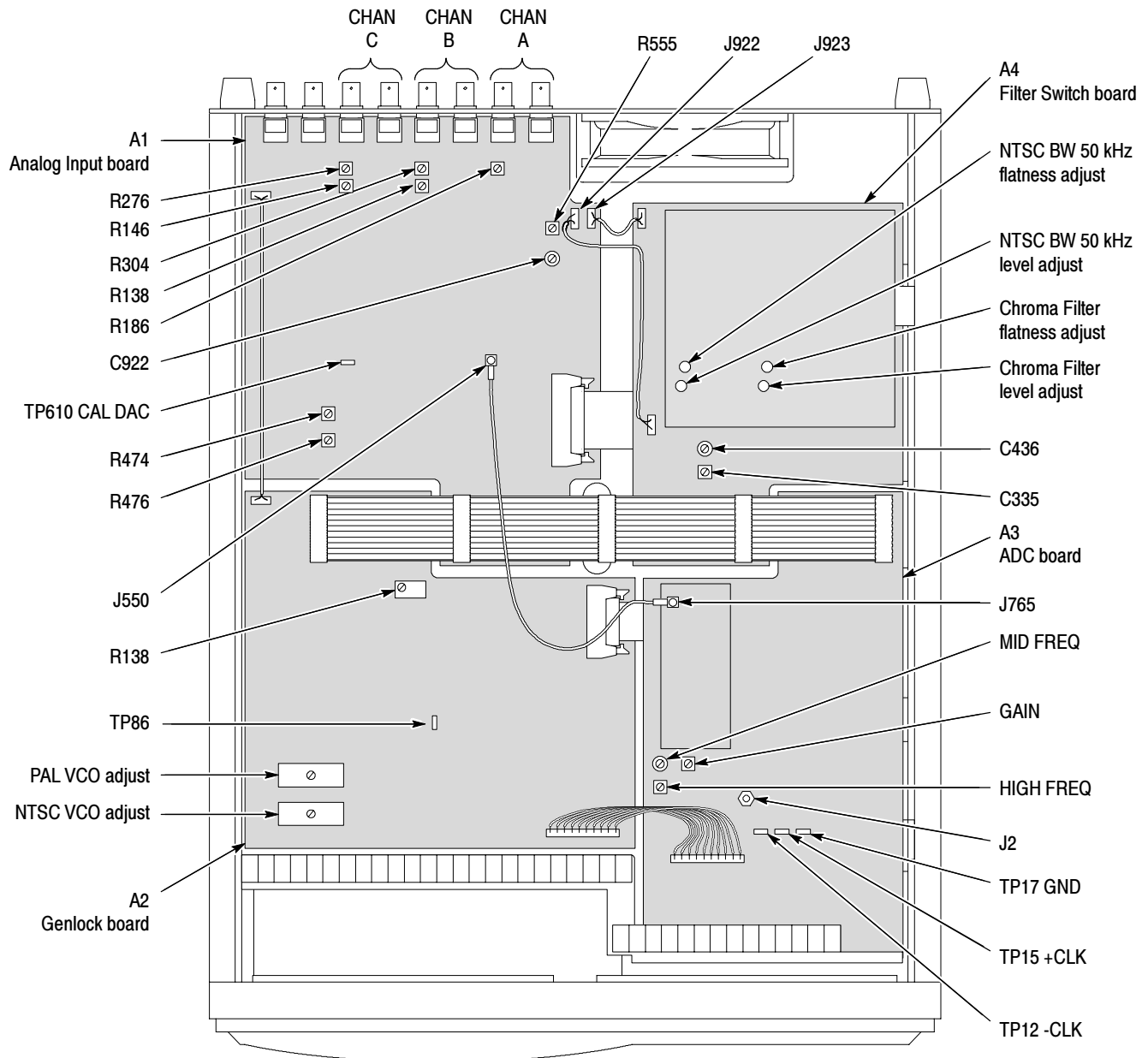

Figure 5-1: Adjustment locations

14. Touch the Zero Set soft key to set the measurement reference for the internal oscillator.
15. Connect the signal generator (full field and burst) to the channel A input (terminate the loop through with a 75 Ω BNC termination).

16. Check that the burst frequency measurement is 0 ± 10 Hz using the internal frequency reference. Do this procedure for NTSC and PAL TV signals if the VM700T is a dual standard instrument.

NOTE. *If the VM700T meets the limits described, skip step 17. Adjusting the VM700T unnecessarily (for example, to get a “better” reading on a calibration result that is within limits) can introduce errors into a functional instrument.*

17. If adjustment is needed, slide the top cover back enough to expose the Genlock board and quickly adjust R138, TCXO REFERENCE, on the Genlock board to set the Burst Frequency measurement to zero. Slide the top cover back on the VM700T. After 5 minutes, check the Burst Frequency measurement again to verify that it remains within tolerance.

NOTE. *If you performed this procedure after getting out-of-limit results from Measuring the Burst Frequency in the Performance Verification procedure return to finish the verification steps now.*

Adjust Filter Flatness

This procedure is used to adjust the frequency response flatness over the operating range of the VM700T after a board exchange repair or after it is determined that the flatness is out of tolerance by doing the Measure Sinewave check procedure.

Test Equipment Required

- Leveled sine-wave generator, 75 Ω output impedance, output flat within ± 0.025 dB ($\pm 0.3\%$) to 6 MHz. Example: HP 3336C with option 005.
- Termination, 75 Ω precision, Tektronix part number 011-0102-01, or equivalent.
- Coaxial cable, 75 Ω high-quality noise free; 1-meter length. Tektronix part number 012-0074-00.

Adjusting Filter Flatness

1. Set the leveled sine-wave generator for 50 kHz at 500 mV into 75 Ω .

NOTE. *If the example leveled sine-wave generator is being used, the output level is set to -3.81 dBm.*

2. Connect channel A of the VM700T to the leveled sine-wave generator and terminate the channel A loop-through output connection in 75 Ω .

3. Press the Measure hard key and move to the VM700T Diagnostics directory by pressing the Diags soft key if necessary. In the Diagnostics directory, run the sine-wave measurement application by pressing the Measure~Sinewave soft key.
4. Once the measurement application has initialized, turn averaging on by pressing the Average hard key until the Average hard key light is on. When the display stabilizes, press the Freeze hard key. The Delta Amp reading should remain at 0. If the Delta Amp reading changes, press the Freeze key again, as many times as needed, until the Delta Amp reading remains at 0. This is now the reference to which all other measurements are compared.
5. Set the leveled sine-wave generator for 4.43 MHz; do not change the output level setting.
6. To speed up the response to the frequency change, toggle the Average hard key off, then back on again after the display has re-stabilized.
7. Check that the change in amplitude is within $\pm 0.5\%$ of the 50 kHz reference level stored in step 4. If the amplitude is in tolerance skip to step 8. If it isn't, turn off Averaging (so you can see response changes). Adjust C57 (Mid Frequency) on the ADC board to bring the flatness at 4.43 MHz into specification (approximately $\pm 0.02\%$ or less difference when compared to the 50 kHz reference).
8. Set the leveled sine-wave generator for 5.8 MHz, but do not change the output level setting.
9. If Averaging is on, speed up the response to the frequency change by toggling the "Average" hard key off, then back on again after the display has re-stabilized.
10. Check that the amplitude is within $\pm 0.55\%$ of the reference level stored in step 4. If it is in tolerance skip to step 11.

If the amplitude is out of tolerance, you can try the adjustment of step 7 again to set the amount of change (Delta Amp) to the positive side of the tolerance (that is, nearer the $+0.02\%$ limit) as a compromise. You may also need to start the procedure all over again to re-establish the reference level (it may have drifted slightly from when you first acquired it).

You should next determine if the problem is only on one channel or on all channels. If only one channel is involved, the Analog Input board may need the flatness adjustments for the input channels done (that procedure is described in the Extended Adjustment Procedure later in this section). If all channels are involved, the ADC board may need adjustment or repair (part of the Analog Input board is also a single-channel signal path, but the ADC board is the most likely problem area when all channels are affected).

- 11.** Change the TV standard parameter from PAL to NTSC by pressing the XY Arrow hard key. Change the filter selection from No Filter to NTSC Band-Width Limiting Filter by pressing the Move/Expand hard key until the filter displays NTSC BW Lim.
- 12.** Return the leveled sine-wave generator to 50 kHz; do not change the output level setting.
- 13.** Let the display stabilize.
- 14.** Adjust the NTSC BP filter 50 kHz Level adjust on the Filter Switch board so that the change in amplitude (Delta Amp) is within $\pm 0.02\%$ of the reference level stored in step 4. See Figure 5-1 on page 5-5 for the adjustment locations.
- 15.** Reset the leveled sine-wave generator for 3.6 MHz; do not change the output level setting.
- 16.** Let the display stabilize.
- 17.** Adjust the NTSC BP Filter Flatness adjust on the Filter Switch board so the change in amplitude (Delta Amp) is within $\pm 0.02\%$ of the reference level stored in step 4.
- 18.** Change the Filter parameter from NTSC BW Lim to Chroma BP by pressing the Move/Expand hard key. Don't change the settings on the leveled sine-wave generator.
- 19.** Let the display stabilize.
- 20.** Adjust the Chroma Filter Level adjust, so that the change in amplitude (Delta Amp) is within $\pm 0.02\%$ of the reference level stored in step 5.
- 21.** Change the TV standard parameter to PAL by pressing the XY Arrow hard key.
- 22.** Change the leveled sine-wave generator frequency to 4.43 MHz, but do not change the output level setting.
- 23.** Let the display stabilize.
- 24.** Adjust the Chroma Filter Flatness adjust, so that the change in amplitude (Delta Amp) is within $\pm 0.02\%$ of the reference level stored in step 4.
- 25.** Disconnect the cables and test equipment from the VM700T.

Adjust ADC Gain

The ADC gain is auto-calibrated during normal VM700T operation. This check and adjustment should only be done as part of a board exchange repair to set the adjustment to a nominal setting for auto-calibration.

Test Equipment Required

- Non-metallic, flat-blade adjusting tool. Tektronix part number 003-1364-00.

Adjusting ADC Gain

1. Press the Measure key, then the Diags and the ADC Gain Adjust soft keys.
2. The VM700T should display $100\% \pm 3\%$.

NOTE. *If the VM700T meets the limits described, skip step 3. Adjusting the VM700T unnecessarily (for example, to get a “better” reading on a calibration result that is within limits) can introduce errors into a functional instrument.*

3. If the number displayed is outside the tolerance range, remove the top cover of the VM700T and carefully adjust R21, ADC Gain, on the ADC board (A3) to bring the number to 100%. See Figure 5-1 on page 5-5 for the adjustment location.

Adjust the Calibration DAC (CalDAC)

This procedure adjusts the calibration DAC. Run this procedure by selecting it with the soft key in the Diags directory. Follow the directions displayed on the VM700T screen for adjusting the Analog Input board (A1) amplitude and offset voltages.

Test Equipment Required

- Digital voltmeter with 3-1/2-digit display.
- Non-metallic, flat-blade adjusting tool. Tektronix part number 003-1364-00.

NOTE. *Run this procedure only if Verification Procedure 1 (Measure Square-wave) yields incorrect results. Adjusting the VM700T unnecessarily (for example, to get a “better” reading on a calibration result that is within limits) can introduce errors into a functional instrument.*

Adjusting the CalDAC

1. Press the Measure button and the Diags soft key.
2. Press the CalDAC adjustment soft key.

3. Remove the VM700T top cover and connect the digital voltmeter to TP610 on the analog input board (A1).
4. Adjust R474, CalDac Offset, on the Analog Input board for -1.2793 V.
5. Press the C button.
6. Adjust R476, CalDac Reference, on the Analog Input board for 0.0000 V.
7. Press the C button.
8. Check for a $+1.2777$ V (± 0.001 V) reading at TP610.
9. Press the Measure button to exit the CalDAC procedure.
10. Power off the VM700T and replace the top cover.

NOTE. *If you performed this procedure after getting out-of-limit results from Verification Procedure 1 (Measure Squarewave), return to Procedure 1 now.*

Adjust the Display

This procedure adjusts the display after a monitor or CPU board replacement. The replacement monitor, when supplied by Tektronix, has been aligned for proper operation in the VM700T, but Trace Rotation (a monitor control) and vertical and horizontal centering and size (CPU board controls) may be needed to align the replacement display. The final procedure is to set the power-up display intensity and calibrate the touch screen.

Test Equipment Required

- Non-metallic, flat-blade adjusting tool. Tektronix part number 003-1364-00.

Adjusting the Display Monitor

1. Power off the instrument, disconnect its power cord, and remove the left- and right-side covers.
2. Reconnect power to the VM700T, press and hold the Waveform button when you turn the power on. After the instrument beeps twice release the button, and let it complete its power on initialization. The waveform graticule is the default display at power on.
3. Look at the lower left corner of the waveform graticule. It should form a 90 degree right angle. If not, adjust the Trace Rotation control (located on the left side of the monitor chassis) to level the form graticule trace across the screen.
4. Turn the VM700T off.

5. Press and hold the Menu button while turning on the power. After the VM700T beeps twice to acknowledge the startup mode, release the Menu button. The VM700T then initializes directly into the Low Level Diagnostics Interface with the VM700T startup menu as shown in Figure 5-2.

```

Low Level Diagnostic Interface
(knob moves cursor, "Select Line" inputs selection)

--- VM700T STARTUP MENU ---
Key   Selection
-----
R ... Instrument -RUN MODES- Menu
U ... -UTILITIES- Menu
D ... Low Level -DIAGNOSTICS- Menu
C ... Diagnostics -CONFIGURATION- Menu
H ... Diagnostics -HELP- Menu
T ... Calibrate -TOUCH PANEL INTERFACE-
-----
= ... Reprint           @ ... Abort Menu
-----

Input your selection:

```

Figure 5-2: VM700T startup menu

6. In the startup menu, use the large control knob to highlight the T in the Calibrate Touch Panel Interface line. Press the Select Line button to make the selection to calibrate. The first touch screen calibration instructions are then displayed as shown in Figure 5-4.
7. Use the large control knob to set the current setting to 8. This setting provides the best centering for a connected VGA monitor.
8. Check the horizontal and vertical centering of the display. If display positioning is not satisfactory (off center or horizontal folded back), adjust the appropriate control (Horiz or Vert Centering, located beneath the side retainer plate on the A5 CPU board board, right side of the VM700T, see Figure 5-3) to align the display on the CRT.

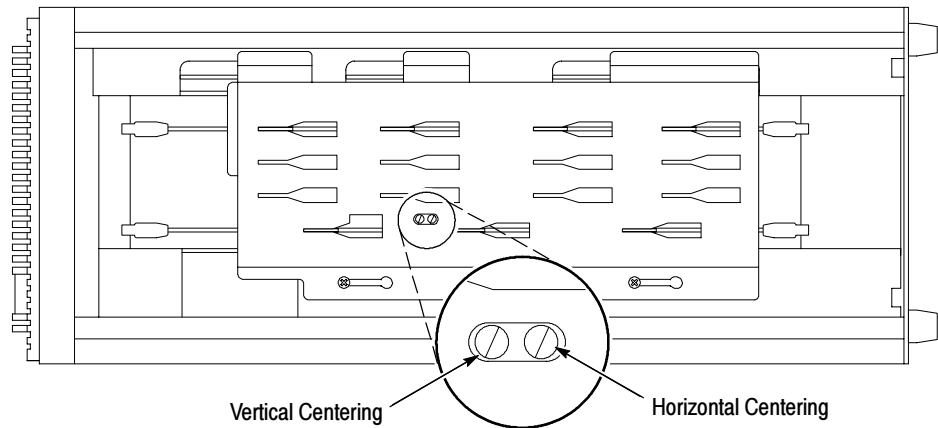

Figure 5- 3: Display monitor centering adjustments

9. After making the adjustment requested and storing the current setting, a second set of instructions is displayed as shown in Figure 5-5. Follow the directions given in the screen to calibrate the touch panel to the CRT display.

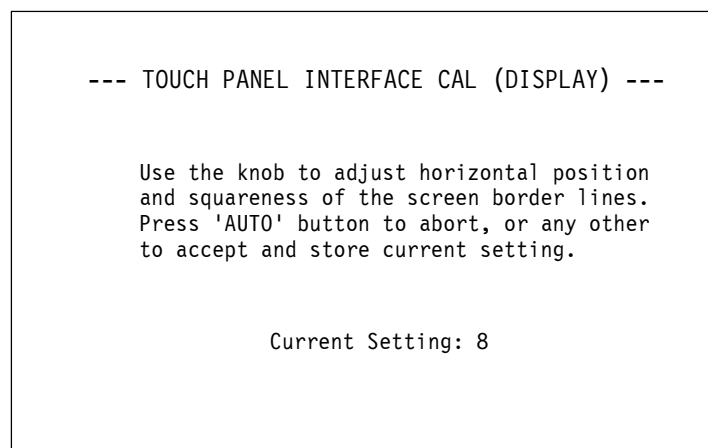

Figure 5- 4: Touch screen calibration (display)

```

  +-----+
  |   o   |
  +-----+
  --- TOUCH PANEL INTERFACE CAL (PANEL) ---
      (press 'AUTO' to abort)

  TOUCH THE DOT INSIDE THE SQUARE
  ---Place finger tip directly over the dot,
      being careful to avoid parallex
  ---Keep touching the dot until the square
      highlights (and beeper sounds)

  SQUARE LOCATIONS SEQUENCE:
  ---SQUARES will appear near
      the screen corners
  ---SEQUENCE will be:
      1, 2, 3, 4, as indicated to the right
  Screen
  +---+---+
  | 1  2 |
  |-----|
  | 3  4 |
  +---+---+

```

Figure 5-5: Touch screen calibration (panel)

- 10.** After the dots at all four corners have been touched, a screen displaying the panel calibration factors is displayed as shown in Figure 5-6. From that screen, you can press any key to return to the VM700T startup menu.

```

  --- PANEL CALIBRATION VALUES ---

  XSCALE = 471      XOFFSET = 292
  YSCALE = -398     YOFFSET = 231

  -#- Press Any Key to Continue -#-

```

Figure 5-6: Panel calibration values

NOTE. Panel calibrations values vary greatly depending on the version of touch panel that is installed in your instrument. The sample values shown are typical of an older touch panel.

- 11.** If the power-on display intensity is not satisfactory, adjust the brightness level. This adjustment is located on the bottom of the CRT display module.

NOTE. The power-up brightness level seldom needs adjustment in normal operation.

- 12.** Power off the VM700T and replace all cabinet covers and retaining screws.
- 13.** Hold the Auto button in and power on the instrument. This runs the full set of diagnostics at power on. Check that the instrument passes all diagnostic tests.

Extended Adjustment Procedure

Adjust the Frequency Response

After a board exchange in the analog input section of the instrument, the analog system may need readjustment. This procedure first checks the overall system response. If the verification checks fail, the system may need readjustment. The adjustments provided are to compensate the system frequency response after a board replacement; they are not complete board level adjustments. Use the adjustments only as necessary to return the instrument to specification.

NOTE. *This procedure requires precision test equipment to make the needed measurements for alignment. If you do not have the required test equipment, it is recommend that you have the adjustment procedure done by Tektronix Customer Service. Contact your nearest Tektronix representative for information.*

Test Equipment Required

- Gain-phase analyzer, 75 Ω output impedance. Example: Hewlett Packard 4194A Impedance/Gain-phase analyzer.
- Leveled sine-wave generator, 75 Ω output impedance; output flat within +0.025 dB ([0.3%]) to 6 MHz. Example: Hewlett-Packard 3336C Sine-wave generator with option 005.
- Coaxial cable, 75 Ω high-quality, low-noise BNC; 1-meter length, 2 each. Tektronix part number 012-0074-00.
- Termination, 75 Ω feed-through BNC. Tektronix part number 011-0055-01.
- Termination, 75 Ω precision BNC. Tektronix part number 011-0102-01.
- Female-to-female adapter BNC. Tektronix part number 103-0070-00.
- Adapter, snap-on SMB male to BNC female, 2 each. Example: Omni/Spectra part number 3280-2224-00.
- Non-metallic, flat-blade adjustment tool. Tektronix part number 003-1364-00.

Specification Checked

- Analog board frequency response: flat within 30 mdB to 8 MHz when checked with setup described.
- System frequency response: flat within 30 mdB to 6 MHz when checked with setup described.

Check the Frequency Response

1. Remove the VM700T top cover to access the adjustments.
2. Set the controls on the gain-phase analyzer as needed. For the example gain-phase analyzer, the controls are set as shown in the gain-phase analyzer setup chart shown in Table 5-2.
3. Disconnect the cable connecting the Analog Input board to the ADC board (J550 to J765) and remove it from the VM700T.

Table 5-2: Gain-phase analyzer setup

Control	Setting
A-max	200 mdB
A/div	30 mdB
Function	GainPhase
Sweep	Log
Osc Level	300 mVolts
Start Freq	100 kHz
Stop Freq	20 MHz
Marker	8 MHz
Output	Dual
Input Ref	75 Ω , 0 dB
Input Test	1 Meg, 20 dB

4. Connect an SMB-to-BNC adapter to a 75- Ω BNC cable, attach a 75- Ω feed-through termination, and connect it to the test channel input connector of the gain-phase analyzer.
5. Connect a second SMB-to-BNC adapter to a 75- Ω BNC cable and connect the BNC end of the second cable to the dual output connector of the gain-phase analyzer.
6. Connect the two cable adapters on the ends of the BNC cables together using the cable removed from between the Analog Input and ADC boards. Normalize the cables and the gain-phase analyzer to remove the cable effects from the measurement (see the gain-phase analyzer operator's manual for the procedure to normalize the cables).
7. Disconnect the SMB cable and the SMB-to-BNC adapter from the BNC cable going to the output of the gain-phase analyzer and connect that cable to the VM700T channel A input (terminate channel A with a 75- Ω termination).

8. Connect the input of the gain-phase analyzer to J550 on the Analog Input board through the SMB cable, SMB-to-BNC adapter, and BNC cable just normalized.
9. Bypass the Filter Switch board by removing the cables from J922 and J923 on the Analog Input board and connecting the jumper (removed from J924) between J922 pin 2 and J923 pin 2.
10. Check that the frequency response for channel A is flat within 30 mdB peak-to-peak (one major division on the example test equipment display) to 8 MHz.

NOTE. *If the frequency response for channel A meets the specification, do not make any adjustment to attempt to improve the response curve of channel A.*

11. If the channel A frequency response is outside the limits specified in step 11, adjust R186, C922, and R555 for a flat response on the analyzer out to 8,018,669.64 Hz. (see Figure 5-1 on page 5-5 for adjustment locations). The following steps describe the procedure.
 - a. Set R186 and R555 at midrange.
 - b. Adjust C922 to get the 6 MHz to 10 MHz portion of the response curve centered.
 - c. Adjust R555 to flatten the response ripple and C922 to control peaking and rolloff of the response curve.
 - d. If the best result is rolled off, adjust R186 to bring the response curve up. If the response curve is peaked, adjust R186 to roll it off. Note that the response is specified only to 8 MHz, so it is permissible to have peaking or roll off above 8 MHz to produce a flatter response curve from 0 to 8 MHz.
12. Store a reference waveform of the channel A frequency response. On the example Gain/Phase Analyzer, press Display, Superimpose, Store, and Recall A.
13. Select #1, select Input Source, and select B on the VM700T for channel B input.
14. Move the cable and terminator to the channel B feedthrough connectors on the rear panel of the VM700T.
15. Check that the channel B response curve matches the stored channel A response curve within specification. If the response curve for channel B does not match the stored channel A trace, adjust R304 (and R138 if necessary) to match the the stored trace.

16. Select C on the VM700T for channel C input.
17. Move the cable and terminator from the channel B connectors to the channel C connectors.
18. Check that the channel C response curve matches the stored channel A response curve within specification. If the response curve for channel C does not match the stored channel A trace, adjust R276 (and R146 if necessary) to match the the stored trace.
19. Remove the gain-phase analyzer cable from the channel C connectors. On the VM700T, select A for channel A input.
20. On the gain-phase analyzer, return to the main menu. Press Recall A to remove the stored trace.

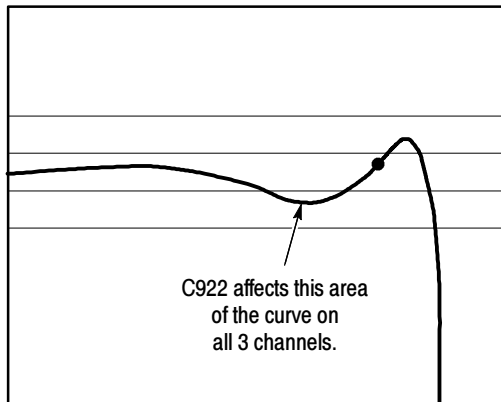

A. Adjust C922 for best flatness on all channels.

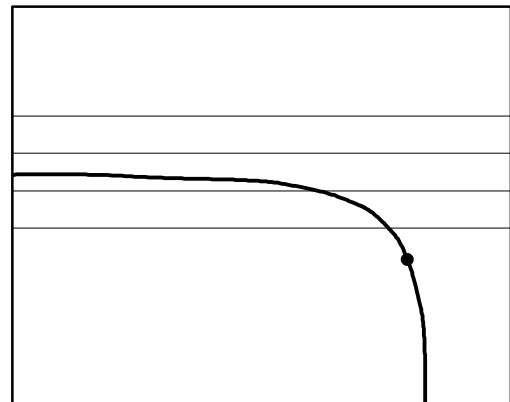

B. Bandpass is too low. Adjust the Input C for the affected channel.

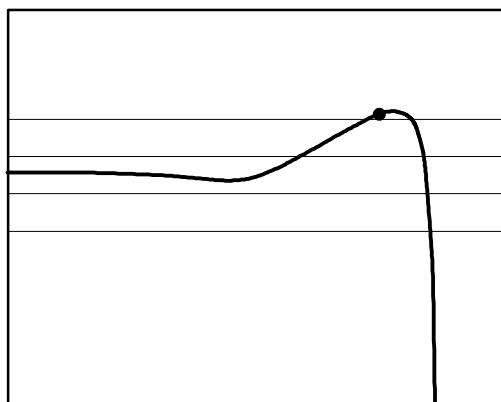

C. Bandpass is too wide and peaked. Adjust C436 and C335 for best flatness on all channels.

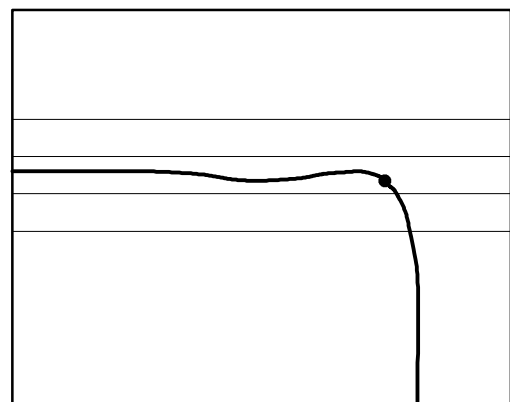

D. Typical correct flatness curve. All points curve within +30 mdB to 8 MHz.

Figure 5- 7: Example gain-phase analyzer flatness waveforms

21. Reinstall the cables and jumpers removed in step 9 to their original positions, but leave the SMB cable between the Analog Input board and the ADC board disconnected.
22. Set the marker on the gain-phase analyzer to 6 MHz and check that the frequency response is flat within 30 mdB peak-to-peak (see Figure 5-7).

NOTE. *If the VM700T meets the limits described in step 16, skip step 17.*

23. If the frequency response is outside the limits specified in step 16, adjust C436 on the filter switch board to bring it into specification. Re-verify that all channels meet specification after adjusting C436. Capacitor C335, may also require adjustment to attain the proper response curve limits. Adjustments of C436 and C335 are interactive and may need to be repeated several times to obtain the best response curve.
24. Reconnect the SMB cable between Analog Input board and the ADC board (J550 to J765), and connect the gain-phase input cable to J2 on the ADC board.
25. Set the controls on the gain-phase analyzer as needed. For the example gain-phase analyzer, the controls are set as shown in the following gain-phase analyzer setups in Table 5-3.

Table 5-3: Gain-phase analyzer setup for ADC

Control	Setting
A-max	-8.4 dB
A/div	30 mdB
Function	GainPhase
Sweep	Log
Osc Level	300 mVolts
Start Freq	100 kHz
Stop Freq	20 MHz
Marker	5.8 MHz
Output	Dual
Input Ref	75 Ω , 0 dB
Input Test	1 Meg, 20 dB

26. Check that the frequency response is flat with 1 division (30 mdB) up to 5.8 MHz on the gain/phase analyzer.

27. If the frequency response is not flat within 30 mdB, adjust C57 (the MID FREQ adjustment) and R22 (the HIGH FREQ adjustment) as needed to obtain the correct response. See Figure 5-1 on page 5-5 for the adjustment locations.
28. Disconnect both gain-phase test cables from the VM700T.
29. Connect the sine-wave generator and a terminator to the inputs of channel A. Set the sine-wave generator for a frequency of 43.297 kHz at a level of -3.81 dBm.
30. Select Measure mode on the VM700T. Then touch the Measure Sinewave soft key. The measured reading is the reference used to compare the rest of the measurement to. It should be approximately 500 mV peak-to-peak.
31. Set the sine-wave generator for a frequency of 4.424959 MHz at a level of -3.82 dBm.
32. Check to see that the measured amplitude is within $\pm 0.02\%$ of the reference level measured in step 30. If it is not, adjust C57 (MID FREQUENCY) until the measured value is within $\pm 0.02\%$.
33. Set the sine-wave generator for a frequency of 5.793146 MHz at a level of -3.81 dBm.
34. Check to see that the measured amplitude is within $\pm 0.55\%$ of the reference level measured in step 30.
35. Power off the VM700T and remove all the test cables.
36. Reinstall the instrument cover panels.

Run the Diagnostics

A final test is to run the complete set of VM700T diagnostics to verify that the system passes the tests.

1. Press and hold the Menu button and power on the VM700T.
2. After about 10 seconds you should hear two beeps from the VM700T. Release the Menu button.
3. In the VM700T Startup Menu shown in Figure 5-8, use the large control knob to select R - Instrument Run Modes Menu.

Low Level Diagnostic Interface
(knob moves cursor, "Select Line" inputs selection)

```

--- VM700T STARTUP MENU ---
Key   Selection
-----
R ... Instrument -RUN MODES- Menu
U ... -UTILITIES- Menu
D ... Low Level -DIAGNOSTICS- Menu
C ... Diagnostics -CONFIGURATION- Menu
H ... Diagnostics -HELP- Menu
T ... Calibrate -TOUCH PANEL INTERFACE-
-----
= ... Reprint           @ ... Abort Menu
-----

Input your selection:

```

Figure 5-8: VM700T startup menu

4. Press the Select Line button to display the Run Mode Menu shown in Figure 5-9.

Low Level Diagnostic Interface
(knob moves cursor, "Select Line" inputs selection)

--- INSTRUMENT RUN MODES MENU ---

The instrument will be reset to run in the mode selected below, overriding current boot switch settings.

```

Key           Selection
-----
N ... NORMAL POWERUP.....Start Instrument in <Powerup Mode>
      Current <Powerup Mode> is QUICK START; abort this menu and go
      to the DIAGNOSTICS CONFIGURATION MENU to change it

P ... POWERUP DIAGS.....Do Diagnostics, start Instrument
Q ... QUICK START.....Skip Diagnostics, start Instrument
L ... LOW LEVEL DIAGS LOOP .....Loop on Low Level Diagnostics
D ... HIGH LEVEL DEBUG.....Start Instrument in <HL Debug Mode>
A ... AUTORESET.....Do EXTRA Diagnostics, start Instrument
-----
= ... Reprint           @ ... Abort Menu
-----

Input your selection:

```

Figure 5-9: Instrument run modes menu

5. In the Run Modes Menu, use the large control knob to select A – Auto Reset and press the Select Line button to activate the selection. This restarts the VM700T and runs the full set of internal diagnostics.
6. Check that all tests pass as they run. If a test fails, refer to *Diagnostics* on page 6–55 for further actions you can take to determine which board or boards may be at fault. If you need further assistance, contact your nearest Tektronix representative or call Tektronix Customer Service.

Option 1S Adjustment Procedure

Required Equipment Table 5-4 lists the test equipment required to perform the adjustments to the VM700T Option 1S hardware.

Table 5-4: Test equipment required for Option 1S adjustment

Equipment	Minimum specification	Purpose	Example
Digital television signal generator	143 Mb, 525-line, NTC7 combination signal; 270 Mb, 525-line, 100% color bars signal; 360 Mb, 525-line, any television signal	Adjusting the Cable Meter and the SDI Eye Diagram horizontal position	Tektronix TG 2000 Signal Generation Platform with a DVG1 module
Clock generator	Wave shape: square wave, duty factor = 40% to 60%; Frequency: 67.5 MHz \pm 5 ppm; Amplitude: 350 to 850 mV p-p; 20 to 80% rise/fall time: \leq 1 ns; Jitter: < 150 ps p-p measured from 10 Hz to 10 MHz ¹	Adjusting the Jitter application	Tektronix TG 2000 Signal Generation Platform with a BG1 module (must use the Clock Out connector)
Oscilloscope	100 MHz bandwidth; 10 ns/div; two input channels	Adjusting the 18 MHz reference oscillator	Tektronix 2465
Clock source	1 MHz	Adjusting the 18 MHz reference oscillator	WWV (1 MHz)
Cable clone or 100 meters of cable	Simulate 100 meters of Belden 8281 cable	Adjusting the Cable Meter	SC75A37B Cable Clone or 100 meters of Belden 8281 cable
Coaxial cable; 3	75 Ω impedance, high-quality noise free; 1 meter length	Signal connections; Adjusting the Cable Meter	Tektronix part number: 012-0074-00
BNC female to BNC female connector; 2		Adjusting the Cable Meter	Tektronix part number: 012-0074-00
Termination	75 Ω high-frequency (26 dB to 300 MHz), BNC connector		Tektronix part number: 011-0163-00
Alignment tool	Non-metallic, flat-blade	Adjust potentiometer	Tektronix part number: 003-1364-00

¹ You can measure the jitter of your clock source using the SDI Eye Diagram application. Select Free Run mode on, Filter: 10 Hz, Average mode on and Average set to 4. The horizontal width of the rise and fall traces at the 0 mV level must be less than 150 ps as measured with the timing cursors.

Preliminary Setup

Prepare the equipment as listed below to perform the adjustment procedure.

1. Remove the right-side cover retaining screws on the VM700T as shown in Figure 5-10. Leave the side cover closed. In some steps of the adjustment procedure you will slide the cover back to access internal components.
2. Connect the power cable to the VM700T, and then power on the VM700T measurement set.
3. Watch the power-up text to verify that the VM700T passes all diagnostics as the instrument completes its power up procedure.
4. Press the front-panel **Configure** button.
5. If necessary, set the VM700T to **Digital Mode** using the Mode soft key.
6. Touch the **Configure Files** soft key, and then touch the **Source_Selection Digital** soft key.
7. Use the front-panel knob to highlight the **Digital A:** line, and then touch the highlighted line to cause a box to appear around the current selection.
8. Turn the knob to select **270MB 525-line**, and then touch the **Accept Input** soft key.
9. Touch the **Update & Exit** soft key to exit the configuration file.

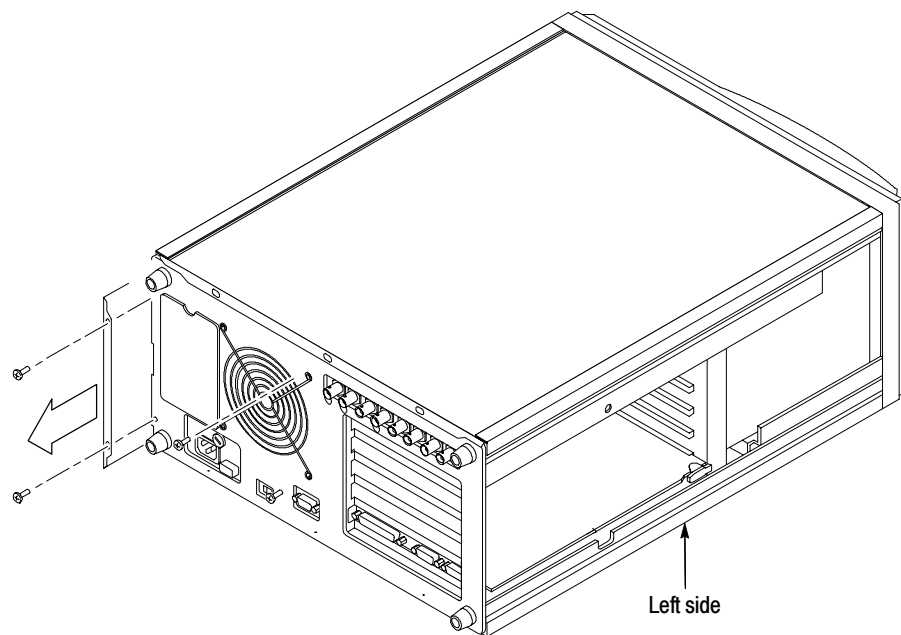

Figure 5-10: Loosening the right-side cover

Adjustment Procedure

Perform the following procedure to adjust the Option 1S hardware.

NOTE. *The VM700T and the Option 1S hardware must be warmed up for at least 20 minutes before you perform any adjustments.*

1. Perform the following steps to adjust the SDI Eye Diagram application gain and offset:
 - a. Remove all signal cables and terminators from the Option 1S inputs.
 - b. Press the VM700T front panel **Measure** button, and then touch the **Diags** soft key.
 - c. Use the front-panel knob to scroll through the on-screen selections, and then touch the **SDI Calibration** soft key.
 - d. Touch the **Eye** soft key (should be highlighted), and then touch the **Calibrate** soft key.
 - e. Check that the displayed New Data values are within the limits shown in Table 5-5.
 - f. If the displayed values are within the required limits, touch the **Accept Data** soft key.

Table 5-5: SDI Eye Diagram application gain and offset value limits

Measurement	New data value limits
Eye circuit gain	1.460 to 1.590
Eye sampler offset	40.000 to 105.000



CAUTION. The following step requires a 67.5 MHz clock that must meet the specifications listed in Table 5-4 on page 5-22 or you will misadjust the instrument.

If you are using the BG1 module of the TG2000 Signal Generation Platform as the clock source, you must use the Clock Out connector on the BG1 module or you will misadjust the instrument.

2. Perform the following steps to adjust the SDI Jitter application:
 - a. Touch the **Jitter** soft key.
 - b. Connect a 67.5 MHz clock to the VM700T SDI Ch. A input. Terminate the SDI Ch. A loopthrough using a 75 Ω high-frequency terminator.
 - c. Touch the **Calibrate** soft key.
 - d. Touch the **Proceed** soft key once to perform the Jitter Scale Factors adjustment.
 - e. Wait until the message at the bottom of the screen disappears.
 - f. Touch the **Proceed** soft key a second time to perform the Jitter Offset adjustment.
 - g. Check that the displayed New Data values are within the limits shown in Table 5-6.
 - h. If the displayed values are within the required limits, touch the **Accept Data** soft key.
 - i. Remove the signal cable from the SDI Ch. A input.

Table 5-6: Jitter application adjustment value limits

Measurement	New data value limits
Jitter scale factors	
Timing	0.650 to 0.800
Align.	0.700 to 0.860
Frame	36.000 to 48.000
Line	72.000 to 97.000
Jitter offsets	
Timing	-0.040 to 0.120
Align.	-0.020 to 0.080
Frame	84.000 to 152.000
Line	84.000 to 152.000



CAUTION. The following Cable Meter adjustment step requires three signals to complete: a 525-line 143 MHz NTC7 combination signal, a 525-line 270 Mb 100% color bars signal, and any 525-line 360 Mb television signal. Do not perform this adjustment unless you have all three signals or you will misadjust the instrument.

3. Perform the following steps to adjust the Cable Meter:
 - a. Touch the **Cable** soft key.

NOTE. Performing the cable meter adjustment requires two cable lengths: 3 meters and 100 meters. If you are using a cable clone to simulate 100 meters, use 3 meters of cable with the cable clone as shown in Figure 5-11.

- b. If you are using a cable clone for this adjustment, connect a 525-line, 143 Mb, NTC7 combination signal from the digital television signal generator to the cable clone input. Connect the cable clone output to the SDI Ch. A input. Be sure the SDI Ch. A loopthrough is terminated using a 75 Ω high-frequency terminator.
- c. If you are using 100 m of cable for this adjustment, connect a 525-line, 143 Mb, NTC7 combination signal from the digital television signal generator to the SDI Ch. A input using a standard-length cable (1 m length). Be sure the SDI Ch. A loopthrough is terminated using a 75 Ω high-frequency terminator.

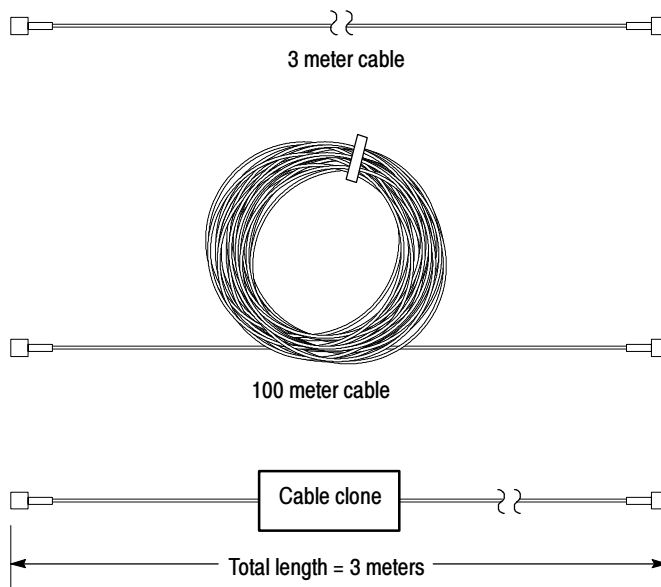

Figure 5- 11: Cable requirements for adjusting the Cable Meter

- d. Touch the **Calibrate** soft key, and then touch the **Proceed** soft key.
- e. Set the cable clone for 100 m of cable or replace the standard-length cable on the SDI Ch. A input with 100 m of cable.
- f. Touch the **Proceed** soft key.
- g. Replace the 143 Mb signal with a 525-line, 270 Mb, 100% color bars signal. Leave the SDI Ch. A input terminated.
- h. Set the cable clone for 0 m of cable or replace the 100 m of cable with the standard-length cable.
- i. Touch the **Proceed** soft key.
- j. Set the cable clone for 100 m of cable or replace the standard-length cable on the SDI Ch. A input with 100 m of cable.
- k. Touch the **Proceed** soft key.
- l. Replace the 270 Mb signal with a 525-line, 360 Mb television signal. Leave the SDI Ch. A input terminated.
- m. Set the cable clone for 0 m of cable or replace the 100 m of cable with the standard-length cable.
- n. Touch the **Proceed** soft key.
- o. Set the cable clone for 100 m of cable or replace the standard-length cable on the SDI Ch. A input with 100 m of cable.
- p. Touch the **Proceed** soft key.
- q. Check that the Cable New Data is within the limits shown in Table 5-7.
- r. If the data is within the limits, touch the **Accept Data** soft key.
- s. Touch the **Update All** soft key, and then touch the **Really Update** soft key.
- t. Replace the cable clone or the 100 m of cable with the standard-length cable. Leave the SDI Ch. A input terminated.

Table 5-7: Cable meter adjustment value limits

Frequency	Cable length	143 Mb new data	270 Mb new data	360 Mb new data
10 MHz demod.	Short	2.200 to 2.700	2.100 to 2.600	2.100 to 2.600
	Long	2.100 to 2.600	2.100 to 2.600	2.000 to 2.500
77 MHz demod.	Short	2.000 to 2.500	2.000 to 2.500	2.000 to 2.500
	Long	1.800 to 2.200	1.800 to 2.200	1.800 to 2.200

4. Perform the following steps to adjust the Eye Diagram horizontal position and delay:
 - a. Slide the VM700T right-side cover back to access the CPU board dip switch.
 - b. Set switch 4 of the dip switch to the open position, and then close the side cover. See Figure 5-12.
 - c. Set the digital television signal generator to output a 525-line, 143 Mb, NTC7 combination signal.

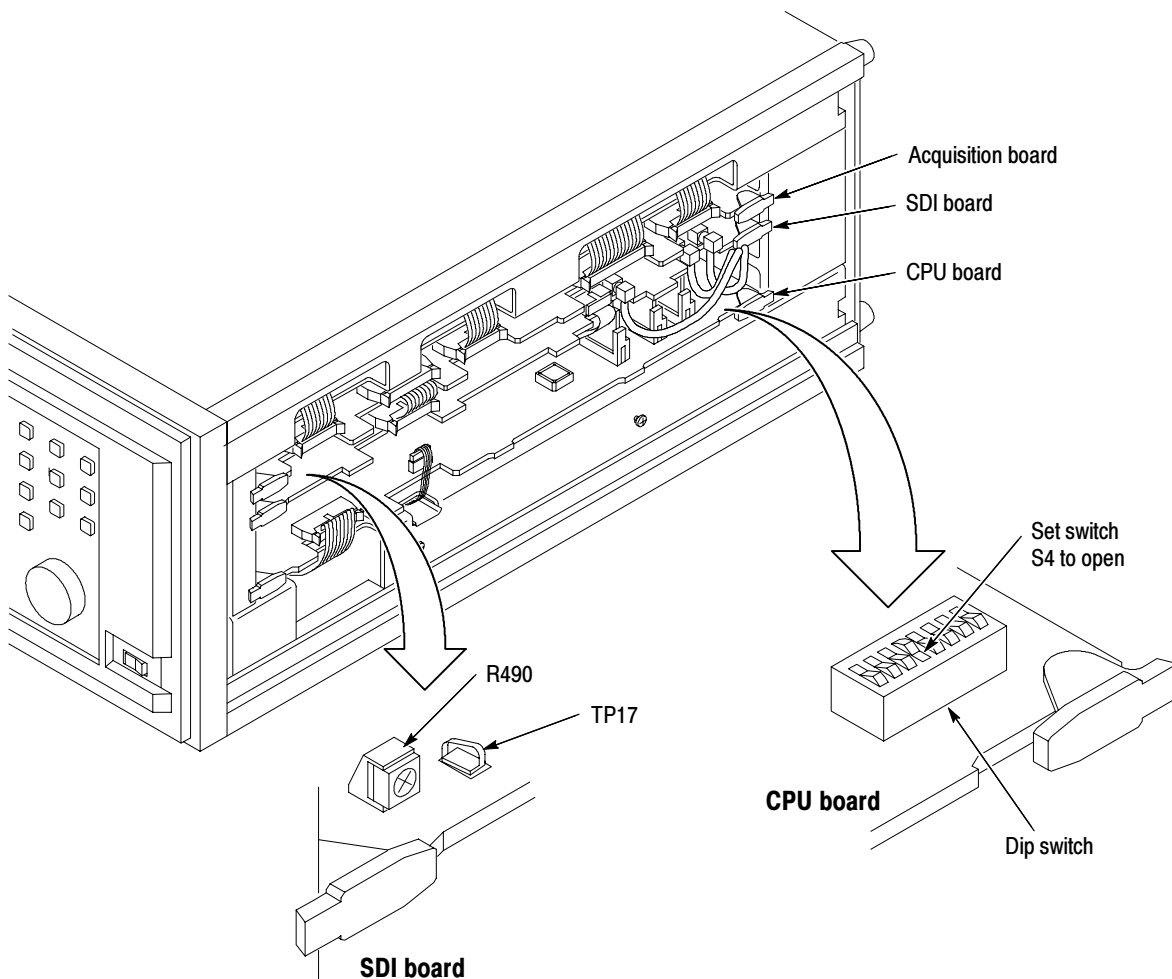

Figure 5- 12: Location of CPU board dip switch and SDI board test point and adjustment resistor

- d. Press the VM700T front-panel **Configure** button.
- e. Touch the **Configure Files** soft key, and then touch the **Source_Selection Digital** soft key.
- f. Highlight the **Digital A:** line using the front-panel knob, and then touch the highlighted line to cause a box to appear around the current selection.
- g. Turn the knob to select **Auto Detect**, touch the **Accept Input** soft key, and then touch the **Update & Exit** soft key to exit the configuration file.
- h. Press the VM700T front-panel **Measure** button.
- i. Touch the **SDI** soft key, and then touch the **SDI_EyeDiagram** soft key.
- j. Press the VM700T front-panel **Menu** button.
- k. Touch the **Waveform** soft key, and then select **Full Signal on** and **Free Run off**.
- l. Check that the readout text in the upper right corner of the display reads 143 Mb.

NOTE. You can set the Eye Diagram horizontal scale units to UI (unit intervals) or to ns (nanoseconds). To set the horizontal scale, touch the **Cursors/Units** soft key, and then touch the **Jitter Units** soft key.

- m. Touch the **Calibrate** soft key (only visible if the CPU dip switch S4 is set to Open), and then touch the **Horz Pos 143 Mbit** soft key.
- n. Turn the front-panel knob to center the left zero crossing of the Eye Diagram at approximately 0.15 UI (1 ns) on the horizontal scale. See Figure 5-13.
- o. Touch the **Horz Pos 143 Mbit** soft key to save the adjustment. A wait message will appear.
- p. Replace the 143 Mb signal on the SDI Ch. A input with a 525-line, 270 Mb, 100% color bars signal.
- q. Check that the readout text in the upper right corner of the display reads 270 Mb.
- r. Touch the **Horz Pos 270 Mbit** soft key.
- s. Turn the front-panel knob to center the left zero crossing of the Eye Diagram at approximately 0.15 UI (0.5 ns) on the horizontal scale. See Figure 5-13.

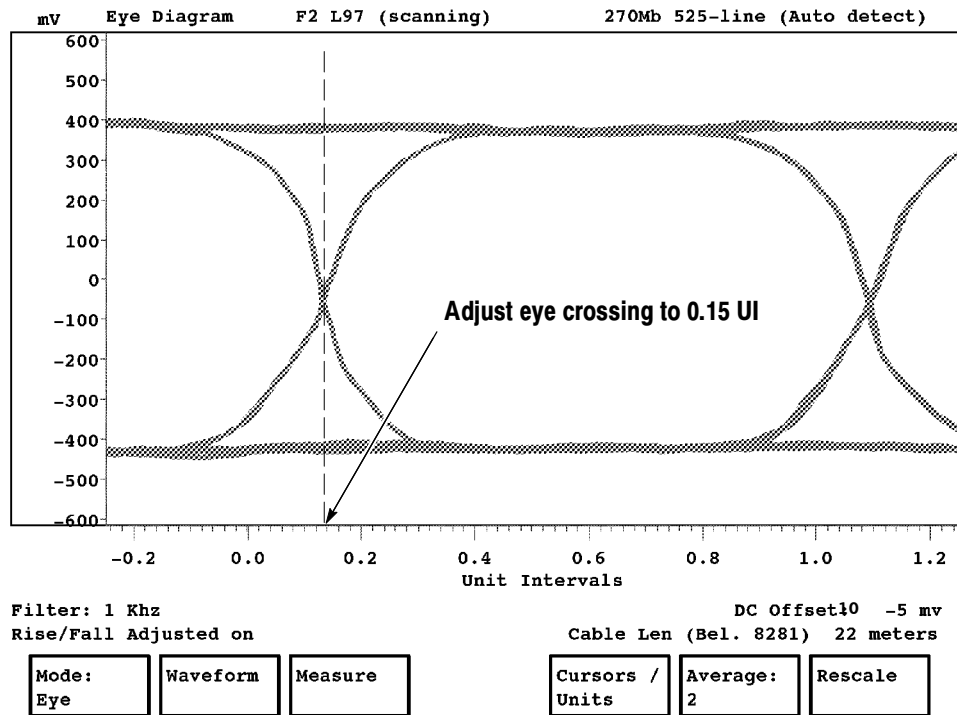

Figure 5-13: Adjusting the eye crossing horizontal position

- t. Touch the **Horz Pos 270 Mbit** soft key to save the adjustment. A wait message will appear.
- u. Replace the 270 Mb signal on the SDI Ch. A input with a 525-line, 360 Mb television signal.
- v. Check that the readout text in the upper right corner of the display reads 360 Mb.
- w. Touch the **Horz Pos 360 Mbit** soft key.
- x. Turn the front-panel knob to the left eye crossing to approximately 0.15 UI (0.4 ns) on the horizontal scale. See Figure 5-13.
- y. Touch the **Horz Pos 360 Mbit** soft key to save the adjustment. A wait message will appear.

- z. Press the VM700T front-panel **Menu** button.
- aa. Touch the **Waveform** soft key, and then deselect the **Falling Edge** and **Non Transitn** soft keys (leave only Rising Edge selected).
- ab. Touch the **Calibrate** soft key, and then touch the **Delay4** soft key.
- ac. Turn the front-panel knob to center the displayed rising edge of the signal. See Figure 5-14.
- ad. Touch the **Delay4** soft key to save the adjustment. A wait message will appear.
- ae. Slide back the right side cover to access the CPU board dip switch.
- af. Set switch 4 of the dip switch to closed, and then slide the cover forward to enclose the circuitry. See Figure 5-12 on page 5-28.
- ag. Press the VM700T front-panel **Menu** button.
- ah. Touch the **Waveform** soft key, and then touch the **Full Signal** soft key.

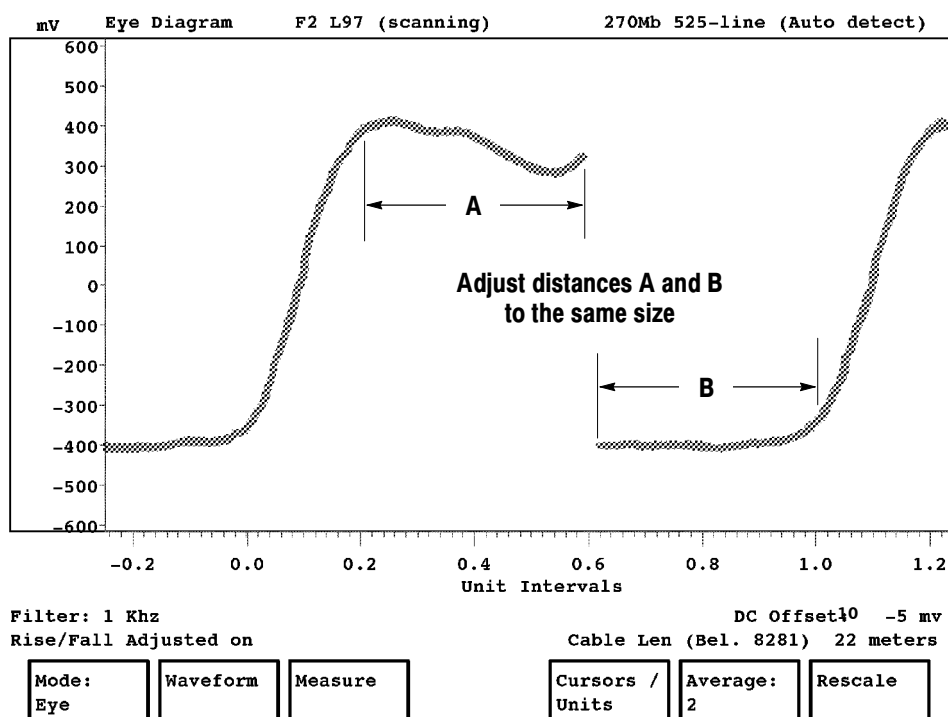

Figure 5-14: Adjusting the rising edge of the SDI Eye Diagram application

NOTE. *The following step adjusts the 18 MHz reference oscillator by observing the slip rate between the oscillator and the 1 MHz WWV reference signal. A slip rate of 10 ns per second results in a maximum error of 0.01 ppm.*

5. Perform the following step to adjust the 18 MHz reference oscillator.
 - a. Slide back the right side cover to access the SDI board test point and adjustment resistor. See Figure 5-12 on page 5-28.
 - b. Connect the 1 MHz WWV reference signal to channel 1 of your oscilloscope.
 - c. Connect a probe from channel 2 of the oscilloscope to TP17 on the SDI board. See Figure 5-12 on page 5-28.
 - d. Set the oscilloscope as follows: 10 ns/div., DC coupled, channel 1 to 500 mV/div. and 1 M Ω DC input, channel 2 to 500 mV/div. and 50 Ω DC input, and triggered to channel 1 (WWV).
 - e. Adjust R490 on the SDI board (see Figure 5-12 on page 5-28) so that the channel 2 signal display on the oscilloscope is stationary (maximum horizontal drift of less than 1 division per second).
 - f. Remove the probe from TP17 on the SDI board.
 - g. Slide the cover forward and install the side cover retaining screws. See Figure 5-10 on page 5-23.
 - h. Remove all cables and terminators from the VM700T.

Maintenance

Preventive maintenance consists of cleaning, visual inspection, performance verification, and, if needed, readjustment. The preventive maintenance schedule established for the instrument should be based on its environment and the amount of use. Under average conditions, preventive maintenance should be performed every 12 months of operation.

NOTE. *If the instrument does not function properly, troubleshooting and corrective measures should be taken immediately to prevent additional problems.*

If the instrument fails during the warranty period, contact your local Tektronix representative. No user repair should be attempted during the warranty period.

This section contains the following information:

- Servicing preparation page 6-1
- Inspection and cleaning page 6-4
- Repackaging the instrument page 6-5
- Removal/replacement instructions page 6-6
- VM700T rack mounting instructions page 6-44
- Troubleshooting procedures page 6-49

Servicing Preparation



CAUTION. *The following procedures should be performed only by qualified service personnel. Performing these procedures incorrectly could result in damage to the instrument.*

Before you begin to service this instrument, perform the following steps:

- Read the *General Safety Summary* and the *Service Safety Summary* at the front of this manual.
- Read the *Operating Information* section of this manual.
- Read the *Preventing Electro-Static Damage* instructions and the *Customer Service* information on the following pages.

Preventing Electro-Static Damage

This instrument contains electrical components that are susceptible to damage from electro-static discharge. Static voltages 1 kV to 30 kV are common in unprotected environments. Table 6-1 shows the relative static discharge susceptibility of various semiconductor classes.

Table 6-1: Static susceptibility

Relative susceptibility levels ¹	Voltage
MOS and CMOS	100 - 500 V
ECL	200 - 500 V
Schottky Signal Diodes	250 V
Schottky TTL	500 V
HF Bipolar Transistors	400 - 600 V
JFETs	600 - 800 V
Linear microcircuits	400 - 1,000 V (est.)
Low-Power Schottky TTL	900 V
TTL	1,200 V

¹ **Voltage equivalent for levels (voltage discharged from a 100 pF capacitor through a 100 Ω resistance).**

Observe the following precautions to avoid damage:

- Minimize handling of static-sensitive components.
- Transport and store static-sensitive components or assemblies in their original containers, on a metal rail, or on conductive foam. Label any package that contains static-sensitive components or assemblies.
- Discharge the static voltage from your body by wearing a wrist grounding strap while handling these components.
- Nothing capable of generating or holding a static charge should be allowed on the work station surface.
- Keep the component leads shorted together whenever possible.
- Pick up the components by the body, never by the leads.
- Do not slide the components over any surface.
- Servicing static-sensitive assemblies or components should be done only at a static-free work station. Avoid handling components in areas that have a floor or work surface covering capable of generating a static charge.
- Use a soldering iron that is connected to earth ground. Use only special antistatic, suction, or wick-type desoldering tools.

Customer Service

For service, parts, module exchange, returns, or technical support in the United States, call the Tektronix Customer Service line between 8:00 AM and 5:00 PM Pacific Time, Monday through Friday at this phone number:

1-800-833-9200

Customer service personnel will direct your inquiry to the proper support group.

Exchanging VM700T Modules. If you call for a module exchange, you must supply the instrument serial number, the firmware version number (accessed by pressing the Configure button), and the module's complete part number to ensure receiving the correct replacement. If the module you request is in stock, it will usually be sent to you the same day.

After you receive the replacement module, the faulty module must be returned immediately to Tektronix using prepaid common-carrier freight. Use the packaging material from the replacement module and the furnished shipping label to prepare the faulty module for shipment. Ship the faulty module to:

Tektronix Inc.

Customer Service Materials
M/S 58-185
PO Box 500
Beaverton, Oregon 97077-0500

Tektronix charges a standard fee for each out-of-warranty module exchanged. This fee will be quoted when you request the exchange module. If the faulty module is not received at the above address within 30 days of your request of an operating exchange module, the full catalog price of the module will be invoiced.

If your module has been damaged or modified in any of the following ways it is not eligible for exchange.

- The module is damaged during repair attempts by personnel other than Tektronix Representatives.
- The module is damaged through improper use or connection to incompatible equipment.
- The module has been modified by the customer.
- The module has been modified to the customer's specifications by Tektronix.

In these cases Tektronix invoices the full catalog price of a replacement module. Call your local Tektronix field office for further information.

Customer Service Outside the U.S. Customers outside the United States should contact their local Tektronix sales subsidiary or distributor for details on servicing the VM700T.

Inspection and Cleaning



CAUTION. *Cleaning and general maintenance of the VM700T should be performed only when the instrument is powered off and the power cord removed from electrical mains.*

Cleaning

The instrument should be cleaned often enough to prevent dust or dirt from accumulating. Dirt acts as a thermal insulating blanket that prevents effective heat dissipation, and can provide high-resistance electrical leakage paths between conductors or components in a humid environment.

Use the following tools to clean the instrument:

- Clean, nonabrasive, lint-free cloth.
- Nonabrasive liquid glass cleaner.
- Isopropyl alcohol.
- Static free vacuum cleaner with small brush attachment.

Cleaning the Exterior. Clean the dust from the outside of the instrument by wiping with a soft cloth. You may use a brush to remove dust from around the selector buttons, knobs, and connectors. Hardened dirt may be removed with a cloth dampened in water that contains a mild detergent or non-abrasive glass cleaner. Abrasive cleaners should not be used.

Cleaning the CRT Touch Screen. Clean the CRT touch screen by carefully applying a small quantity of glass cleaner and wiping the screen dry with a clean, nonabrasive, lint-free cloth.

Cleaning the Front Bezel Air Filters. At regular intervals, inspect the air filters through the front-bezel air-intake slots for accumulated dust. Carefully vacuum the front of the instrument to remove any accumulated dust.

Cleaning the Interior. Use low-pressure dry air to remove accumulated dust and dirt (high-velocity air can damage some parts). Hardened dirt or grease may be removed with a cotton swab or pipe cleaner dampened with isopropyl alcohol. Abrasive cleaners should not be used. If the circuit board assemblies must be removed for cleaning, follow the instructions in the removal and replacement procedures of this section.



CAUTION. Do not allow water to get inside any enclosed assembly or component. Do not clean any plastic materials with organic cleaning solvents, such as benzene, toluene, xylene, acetone, or similar compounds, because they may damage the plastic.

After cleaning, allow the interior to thoroughly dry before applying power to the instrument.

Visual Inspection

After cleaning, carefully check the instrument for defective connections, damaged parts, and improperly seated transistors, integrated circuits, or circuit boards. The remedy for most visible defects is obvious; however, if heat-damaged parts are discovered, determine the cause of overheating before replacing the damaged part, to prevent additional damage.

Periodic checks of the transistors and integrated circuits are not recommended.

Repackaging the Instrument

Repackage the instrument in the original manner to provide adequate protection. If the original packaging is not available or is unfit for use, repackage and identify the instrument as described here.

Identification Tag

If the instrument is to be shipped to a Service Center for service or repair, attach a tag to the instrument showing the following information:

- Owner (with complete address) and the name of the person at your firm that can be contacted.
- Instrument serial number and a description of the service required.

Repackaging

1. Obtain a corrugated cardboard carton whose inside dimensions are at least six inches greater than the dimensions of the instrument to allow room for cushioning. The shipping carton should have a test strength of at least 275 pounds.
2. Surround the instrument with polyethylene sheeting to protect the finish.
3. Cushion the instrument on all sides by tightly packing dunnage or urethane foam between the carton and the instrument. Allow three inches on all sides for cushioning.
4. Seal the carton with shipping tape or an industrial stapler.

Removal and Replacement Instructions



WARNING. *This instrument contains hazardous voltages. Before removing covers or performing disassembly/reassembly procedures, always shut off instrument power at the rear-panel switch and disconnect the power cord from electrical mains. Failure to do this may result in dangerous electrical shock.*



CAUTION. *To prevent static discharge damage, observe the precautions listed in Preventing Electro-Static Damage on page 6-2.*

This section includes removal and replacement procedures for the following assemblies:

- Cover panel page 6-8
- I/O board page 6-9
- Option 40 and Option 41 audio boards page 6-11
- Option 41 connector installation page 6-12
- Option 48 GPIB Interface board page 6-14
- CPU board page 6-15
- Acquisition Memory board page 6-18
- Option 1S SDI board page 6-19
- Analog Input board page 6-23
- Genlock board page 6-25
- ADC board page 6-28
- Filter Switch board page 6-30
- Display and control components page 6-32
- Power supply, Interconnect board, VGA board, and cooling fan page 6-38

Locating the Major Standard Assemblies

As you face the front of the VM700T (in its operating position), the CPU (A5) is located in the right-side card cage along with the Acquisition Memory (A18). The I/O board and any of the hardware option boards are located in the left-side card cage. The analog section boards (Analog Input A1, Genlock A2, ADC A3, and Filter Switch A4) are mounted, with screws and standoffs, on a bulkhead under the top cover panel (see Figure 6-1).

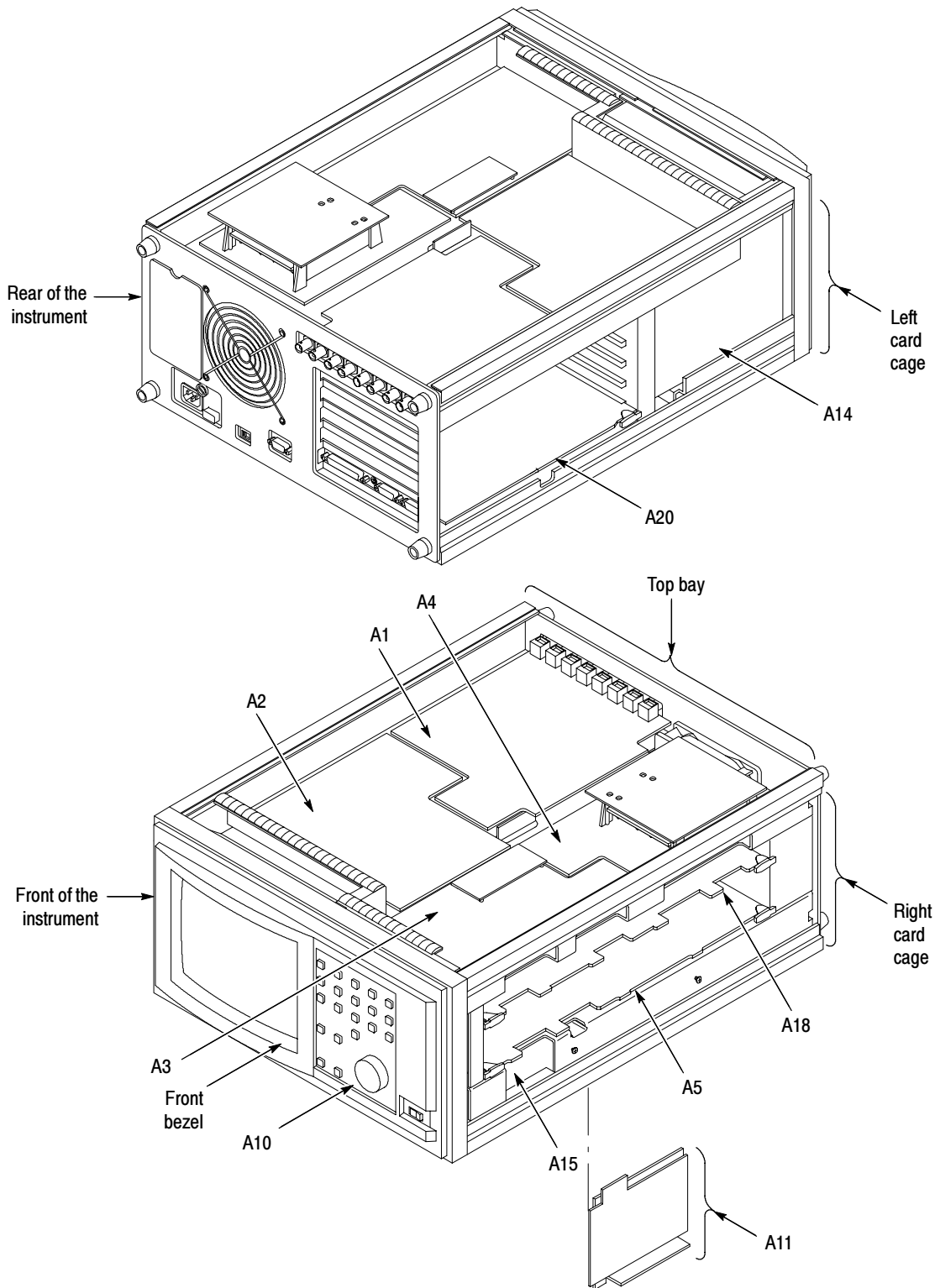

Figure 6-1: Locating the major standard assemblies

Cover Panel Removal and Replacement

Most of the VM700T circuit boards may be accessed by first removing three sheet-metal panels that cover the top and two sides of the instrument. Removing the keypad board assembly (and other display and control components) from the front of the instrument also requires removing the bottom cover panel.

The four cover panels are positioned with slotted corner extrusions and fastened with screws to the instrument rear panel. Removing each cover panel requires removing its fastening screws on the rear panel and sliding the panel toward the rear of the instrument and out of the grooves in the chassis frame. Replacing each cover panel is the reverse of the removal procedure.

Required Tools. Use the following tool to remove the cover panels:

- Pozidriv® screwdriver, 1X.

Procedure. Use the following procedure to remove and replace the cover panels.

1. Remove the screws at the rear edge of the cover panel to be removed.
2. Remove the panel by sliding it carefully to the rear of the instrument and out of the grooves in the chassis frame (see Figure 6-2).
3. Replace the cover panel by guiding it into the chassis grooves, sliding it all the way to the front of the instrument, and installing the screws.

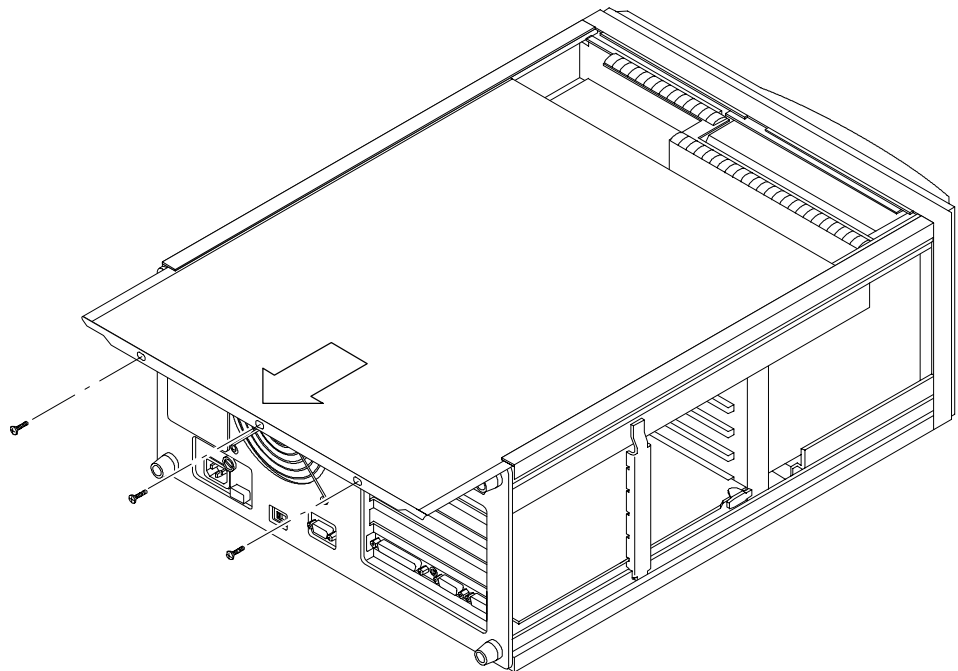

Figure 6-2: Removing a cover panel

I/O Board Removal and Replacement

To remove the I/O board (A20) you must first remove the left side cover panel and the retainers and screws holding the boards in the card cage.

Required Tools. Use the following tools to remove the I/O board:

- Flat-blade screwdriver, $\frac{3}{16}$ or $\frac{1}{4}$ inch blade.
- Pozidriv screwdriver, 1X.

Procedure. Use the following procedure to remove and replace the I/O board.

1. Perform the following steps to remove the I/O board:
 - a. Remove the left side cover panel (refer to *Cover Panel Removal and Replacement* on page 6-8).
 - b. Remove the retaining screw from the card cage center support and remove the center support from the card cage (see Figure 6-3).
 - c. Remove the circuit board retaining screw from the I/O board.

NOTE. *It may also be necessary to remove or loosen the circuit board retaining screw immediately above the circuit board you are removing.*

- d. Unplug the I/O board using the ejector tab to release the board from the main interconnection board, and remove the board from the card cage.
2. Perform the following steps to replace the I/O board:
 - a. Guide the board onto the card cage track and slide it into the card cage (see Figure 6-4).
 - b. Align the circuit board connector pins with the connector on the main interconnection board and press firmly to seat the connector.
 - c. Replace the circuit board retaining screw.
 - d. Replace the circuit board center support and screw.
 - e. Replace the cover panel (refer to *Cover Panel Removal and Replacement* on page 6-8).

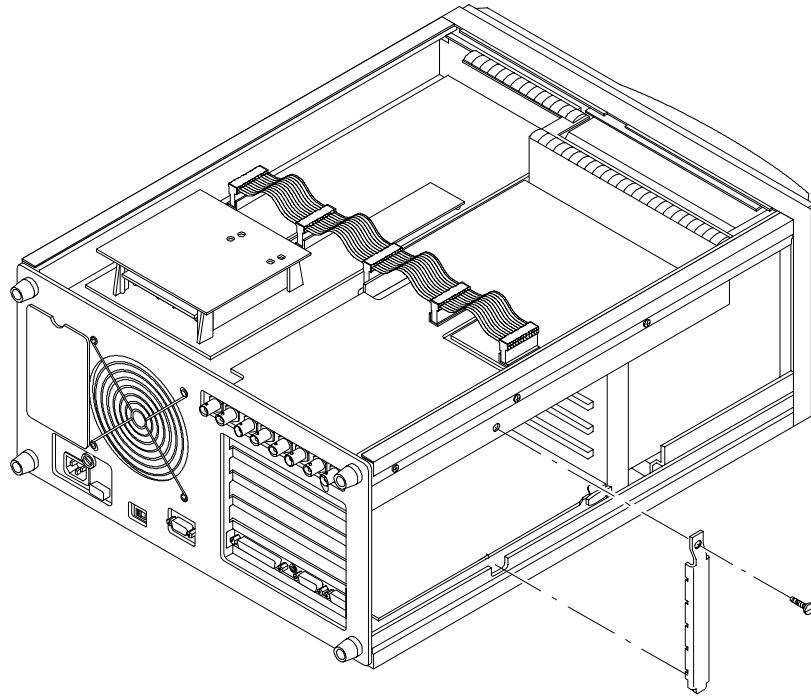

Figure 6-3: Removing the left card cage center support

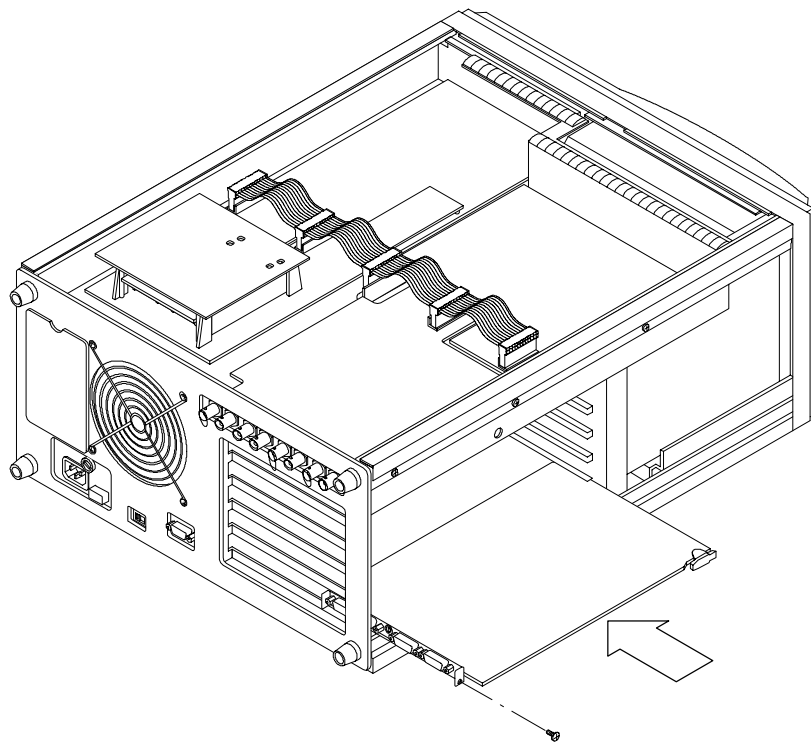

Figure 6-4: Installing the I/O board in the card cage

Option 40 and Option 41 Audio Boards Removal and Replacement

As you face the front of the VM700T (in its operating position), the Audio Processor (A12), and Audio Analog (A17) boards are located in the left-side card cage with the I/O board (A20) and, if installed, the GPIB Interface Option (A19) board.

You may use these procedures to remove and replace both boards. To remove these boards you must first remove the left side cover panel to gain access. Then, remove the retainers and screws holding the boards in the card cage. If you are removing only one of the boards, first remove the flat cable between the boards, at connector J9. Otherwise, leave the flat cable connected and remove both boards at the same time. Figure 6-5 shows where the audio option boards are located in the left-side card cage.

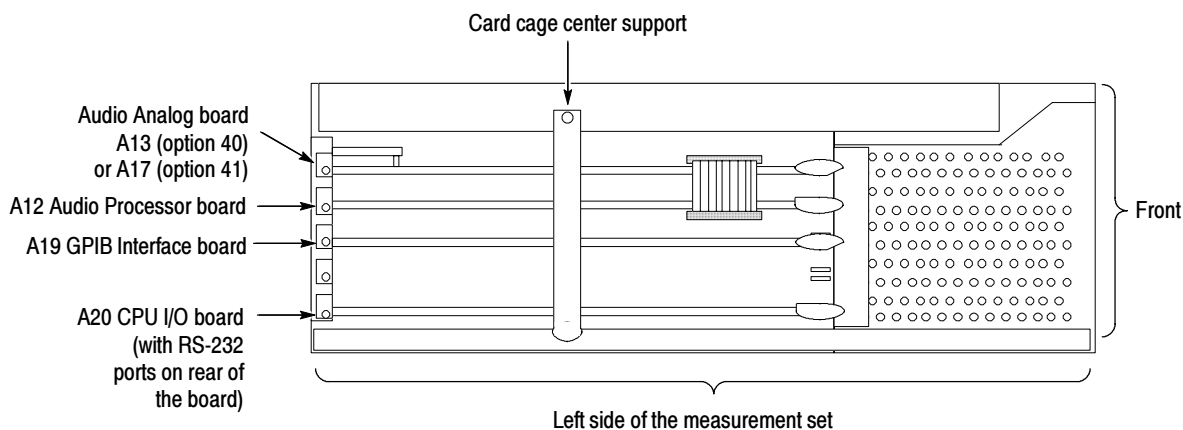

Figure 6-5: Locating audio option boards in the left-side card cage

Required Tools. Use the following tools to remove the Option 40 or Option 41 circuit boards:

- Flat-blade screwdriver, $\frac{3}{16}$ " or $\frac{1}{4}$ " blade.
- Pozidrive screwdriver, 1X.

Procedure. Use the following procedure to remove and replace the Audio boards.

1. Perform the following steps to remove the Audio boards:
 - a. Remove the left side cover panel (refer to *Cover Panel Removal and Replacement* on page 6-8).
 - b. Remove the retaining screw from the card cage center support and remove the center support from the card cage (see Figure 6-3 on page 6-10).

- c. Remove the circuit board retaining screw from the appropriate circuit board.

NOTE. *It may also be necessary to remove or loosen the circuit board retaining screw immediately above the circuit board you are removing.*

- d. If you are removing only one of the audio option boards, disconnect the flat cable between them at J9.
 - e. Unplug the circuit board using the ejector tab to release the board from the main interconnection board. Remove the board from the card cage.
2. Perform the following steps to install the Audio boards:
- a. Guide the audio boards onto the card cage track and slide it into the card cage connector (see Figure 6-4).
 - b. Align the circuit board connector pins with the main interconnection board connector and press firmly to seat the connector.
 - c. Replace the circuit board retaining screw.
 - d. Replace the circuit board center support and screw.
 - e. If you disconnected the flat cable at J9, replace it now (otherwise, verify that the cable is seated correctly in the connectors).
 - f. Replace the carrying handle cover and screws.

Option 41 Connector Installation

The VM700T with Option 41 includes a 37-pin connector located on the instrument back panel. Pin assignments for the connector are listed in Table 6-2.

Table 6-2: Audio Option 41 connector pin assignments

Audio input	+Signal ¹	-Signal	Shield
1 Left	1	2	3
1 Right	21	22	20
2 left	4	5	6
2 Right	24	25	23
3 Left	7	8	9
3 Right	27	28	26

¹ For single-ended input: connect single-ended inputs to a + Signal pin; connect -Signal pin to shield.

Tektronix supplies a DB-37 mating connector kit for Option 41 users for assembling the signal interconnection cabling. The supplied kit, provides several sizes of cable adapter collars. Select the one fits your cable, and put it on the cable before assembling the wiring to the connector as shown in Figure 6-6. See Table 6-2 for the connector pin assignments. The connector pin locations are shown in Figure 6-7. The Tektronix part number for the DB-37 connector is 200-3947-00.

After assembling the connector and checking out the wiring, install the EMI reduction ferrite choke as instructed below.

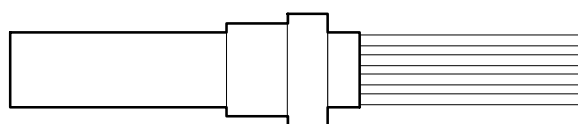

Figure 6-6: Orientation of the cable adapter collar

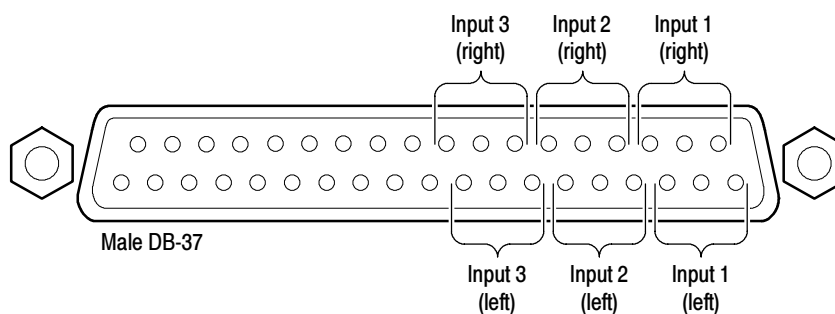

Figure 6-7: Option 41 (Triple-Input Audio) input connector pin locations

Installing the EMI Reduction Ferrite Choke. The EMI reduction parts consist of two ferrite forms and two cable tie wraps to secure the ferrite forms on a multiconductor cable. The ferrite forms fit together on a cable that has an outside diameter of 0.5 inch or less. The ferrite choke consists of the following parts:

- Ferrite forms, 2 ea., Tektronix part number 276-0832-00
- Cable tie wraps, 2 ea., Tektronix part number 346-0120-00

When installed as described on the assembled audio cable, the ferrite forms act as a choke to reduce the level of high-frequency noise emitted from the signal interconnection cabling.

Perform the following steps to install the ferrite choke after assembling the cable to the supplied connector:

1. Place a cable tie wrap around the cable with the tie wrap end started through the tie binder to form a loop.
2. Place both ferrite forms on the cable as shown in Figure 6-8. The parts must be placed as close to the connector as possible.
3. Slide the loop of the tie wrap over the two ferrite halves and tighten the tie wrap firmly. Trim off the excess end of the tie wrap.
4. Place an additional tie wrap around the cable behind the ferrite forms to eliminate the possibility of the assembled parts slipping on the cable. Tighten the tie wrap on the cable and trim off the excess end.

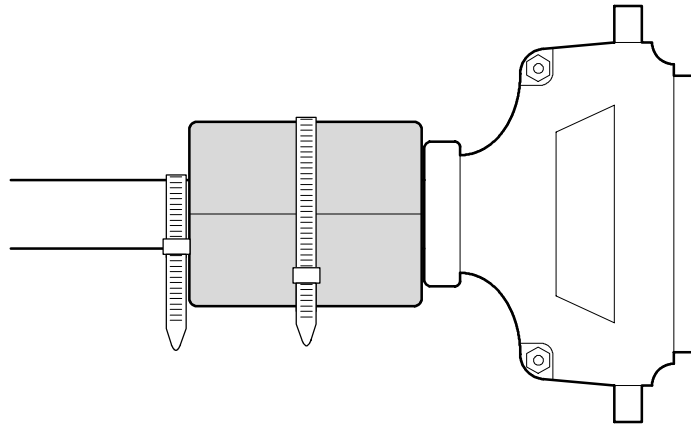

Figure 6-8: Ferrite forms installed on the Option 41 interconnection cable

Option 48 GPIB Interface Board Removal and Replacement

As you face the front of the VM700T (in the operating position), the GPIB Interface board (A19) is located in a card cage on the right side (see Figure 6-5). The GPIB interface option board occupies the second slot above the I/O board. To remove the GPIB board you must first remove the right side cover and the card cage retainer. The following procedures explain how to remove the GPIB board.

Required Tools. Use the following tools to remove the Option 48 circuit board:

- Flat-blade screwdriver, $\frac{3}{16}$ " or $\frac{1}{4}$ " blade.
- Pozidrive screwdriver, 1X.

Procedure. Use the following procedure to remove and replace the Option 48 GPIB Interface board.

1. Perform the following steps to remove the GPIB Interface board:
 - a. Remove the left side cover panel (refer to *Cover Panel Removal and Replacement* on page 6-8).
 - b. Remove the retaining screw from the card cage center support and remove the center support from the card cage (see Figure 6-3 on page 6-10).
 - c. Remove the circuit board retaining screw from the GPIB circuit board.

NOTE. *It may also be necessary to remove or loosen the circuit board retaining screw immediately above the one retaining the circuit board you are removing.*

- d. Unplug the board using the ejector tab and remove the board from the card cage.
2. Perform the following steps to replace the GPIB Interface board:
 - a. Guide the board onto the card cage track and slide it into the card cage connector (see Figure 6-4).
 - b. Align the circuit board connector pins with the main interconnection board connector and press firmly to seat the connector.
 - c. Replace the circuit board retaining screw.
 - d. Replace the circuit board center support and screw.
 - e. Replace the carrying handle cover and screws.

CPU Board Removal and Replacement

As you face the front of the VM700T (in the operating position), the CPU board (A5) is located in a card cage on the right side. To remove this board you must first remove the right side cover and the card cage retainer. You must also disconnect one or more cables from the board. The following procedures explain how to remove the CPU board.

Required Tools. Use the following tools to remove the CPU circuit board:

- Flat-blade screwdriver, $\frac{3}{16}$ or $\frac{1}{4}$ inch blade.
- Pozidriv screwdriver, 1X.

Procedure. Use the following procedure to remove and replace the CPU board.

1. Perform the following steps to remove the right-side card cage retainer:
 - a. Remove the right side cover panel (refer to *Cover Panel Removal and Replacement* on page 6-8). Loosen (but do not remove) two screws on the front of the card cage retainer (see Figure 6-9).
 - b. Slide the retainer carefully to the left, until the screw heads clear the slots, and then remove the retainer to expose the CPU board for removal.
2. Perform the following steps to remove the CPU board:
 - a. The CPU board occupies the bottom slot of the right-side card cage (see Figure 6-10). Use the cable ejector tabs on the front panel interconnection cable to disconnect that cable from the CPU board at J9.
 - b. Disconnect the multiconductor square-pin connectors going to the display monitor (J7) and the rear panel VGA connector (J6).
 - c. For instruments with serial numbers B050100 and above, disconnect the Touch Panel connector from J5 on the CPU board.
 - d. Unplug the circuit board using the ejector tab to release the board from the main interconnection board. Slide the circuit board out of the card cage, ensuring that the standoff on the CPU board clears.

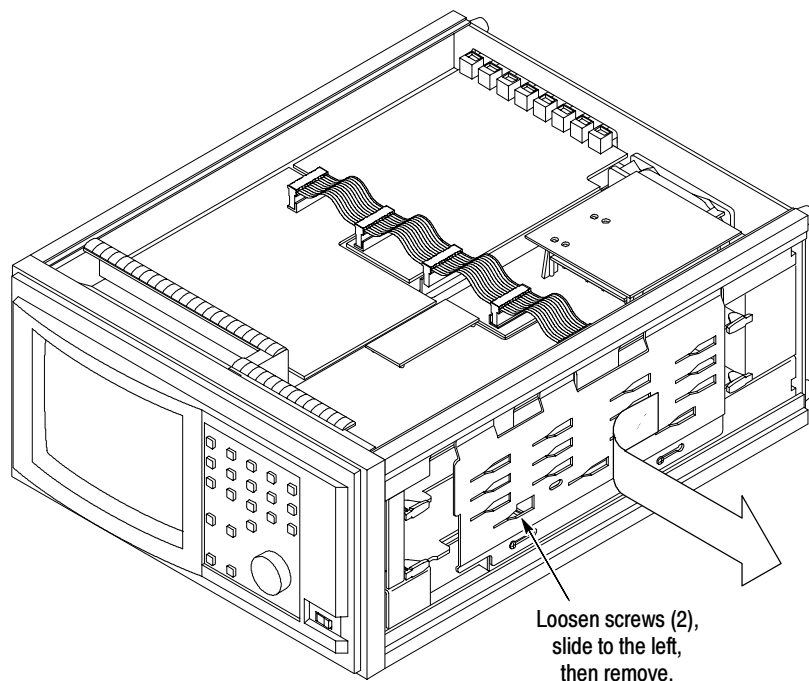

Figure 6-9: Loosening the screws on the right card cage retainer

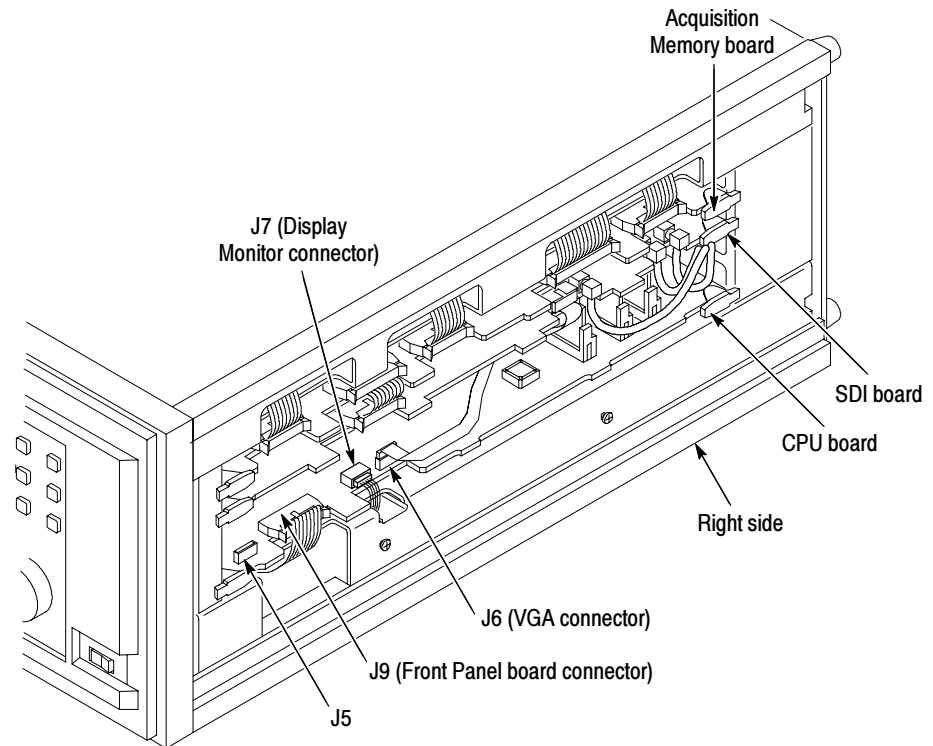

Figure 6-10: Location of right card cage circuit boards

3. Perform the following steps to replace the CPU board:
 - a. Guide the board onto the bottom card cage track and slide it into the card cage connector.
 - b. Align the circuit board connector pins with the main interconnection board connector and press firmly to seat the connector.
 - c. Reinstall each of the four cables, ensuring that they are firmly seated.
4. Perform the following steps to replace the right-side card cage retainer:
 - a. Install the card cage retainer by first inserting its upper tabs through the chassis slots. Complete the installation by guiding the retainer slots carefully over the circuit board locator tabs. See Figure 6-9.
 - b. When the screw heads extend through the slotted holes, lock the card cage retainer in position by sliding it to the right.
 - c. Tighten the retaining screws.
 - d. Install the cover panel (refer to *Cover Panel Removal and Replacement* on page 6-8).

Acquisition Memory Board Removal and Replacement

As you face the front of the VM700T (in the operating position), the Acquisition Memory board (A18) is located in a card cage on the right side. To remove this board you must first remove the right side cover and the card cage retainer. You must also disconnect four cables from the circuit board.

Required Tools. Use the following tools to remove the Acquisition Memory circuit board:

- Flat-blade screwdriver, $\frac{3}{16}$ or $\frac{1}{4}$ inch blade.
- Pozidriv screwdriver, 1X.

Procedure. Use the following procedure to remove and replace the Acquisition Memory board.

1. Perform the following steps to remove the Acquisition Memory board:
 - a. Remove the right side cover panel (refer to *Cover Panel Removal and Replacement* on page 6-8).
 - b. Remove the card cage retainer (refer to step 1 on page 6-16).
 - c. The Acquisition Memory board occupies the top slot in the right-side card cage (see Figure 6-10). To remove this board, you must first disconnect the ribbon cables shown on the right side of Figure 6-11.
 - d. Spread the cable ejector tabs to disconnect each cable from the circuit board.
 - e. Unplug the circuit board using the ejector tab to release the board from the main interconnection board. When the circuit board is loose, slide it out of the card cage.
2. Perform the following steps to replace the Acquisition Memory board:
 - a. Guide the board onto the top right-side card cage track and slide it into the card cage connector.
 - b. Align the circuit board connector pins with the main interconnection board connector and press firmly to seat the connector.
 - c. Reinstall each of the cables to the Acquisition board, ensuring that they are firmly seated in the board connectors (see Figure 6-11).
 - d. Install the card cage retainer (refer to step 4 on page 6-17).
 - e. Install the cover panel (refer to *Cover Panel Removal and Replacement* on page 6-8).

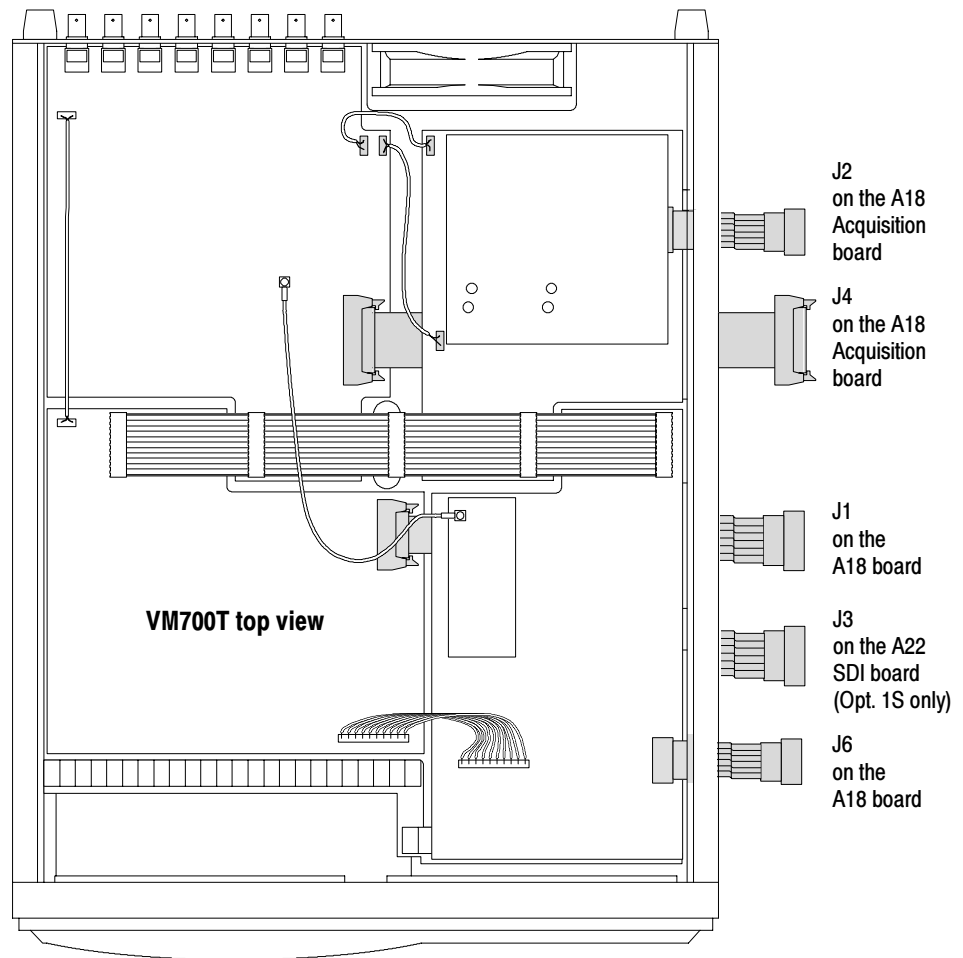

Figure 6-11: Acquisition Memory board (A18) cables

Option 1S SDI Boards Removal and Replacement

The Option 1S hardware consists of an SDI board (A22), an SDI Rear Panel Interface assembly (A23), and interconnecting cables. As you face the front of the VM700T (in the operating position), the SDI board is located in a card cage on the right side. To remove this board you must first remove the right side cover and the card cage retainer. You must also disconnect five cables from the circuit board.

Required Tools. Use the following tools to remove the Option 1S hardware:

- Flat-blade screwdriver, $\frac{3}{16}$ or $\frac{1}{4}$ inch blade.
- Pozidriv screwdriver, 1X, 2X.

SDI Board. Use the following procedure to remove and replace the Option 1S SDI circuit board.

1. Perform the following steps to remove the SDI board:
 - a. Remove the right side cover panel (refer to *Cover Panel Removal and Replacement* on page 6-8).
 - b. Remove the card cage retainer (refer to step 1 on page 6-16).
 - c. The SDI board occupies the second from the top slot in the right-side card cage (see Figure 6-10 on page 6-17). To remove this board, you must first disconnect five cables from the board.
 - d. Disconnect the cables from the SDI board at J8, J7, J10, and J5 (see Figure 6-12). Spread the cable ejector tabs to disconnect the cable from the SDI board at J3.
 - e. Unplug the circuit board using the ejector tab to release the board from the main interconnection board. When the circuit board is loose, slide it out of the card cage.
2. Perform the following steps to replace the SDI board:
 - a. Guide the SDI board onto the second from the top right-side card cage track and slide it into the card cage connector.
 - b. Align the circuit board connector pins with the main interconnection board connector and press firmly to seat the connector.
 - c. Reinstall each of the five cables to the SDI board, ensuring that they are firmly seated in the board connectors (see Figure 6-12).
 - d. Install the card cage retainer (refer to step 4 on page 6-17).
 - e. Install the cover panel (refer to *Cover Panel Removal and Replacement* on page 6-8).

SDI Rear Panel Interface Assembly. As you face the front of the VM700T (in the operating position), the SDI Rear Panel Interface assembly (A23) is located on the right side of the rear panel. To remove this assembly, you must first remove the right side cover and the card cage retainer so that you can disconnect four cables from the SDI board.

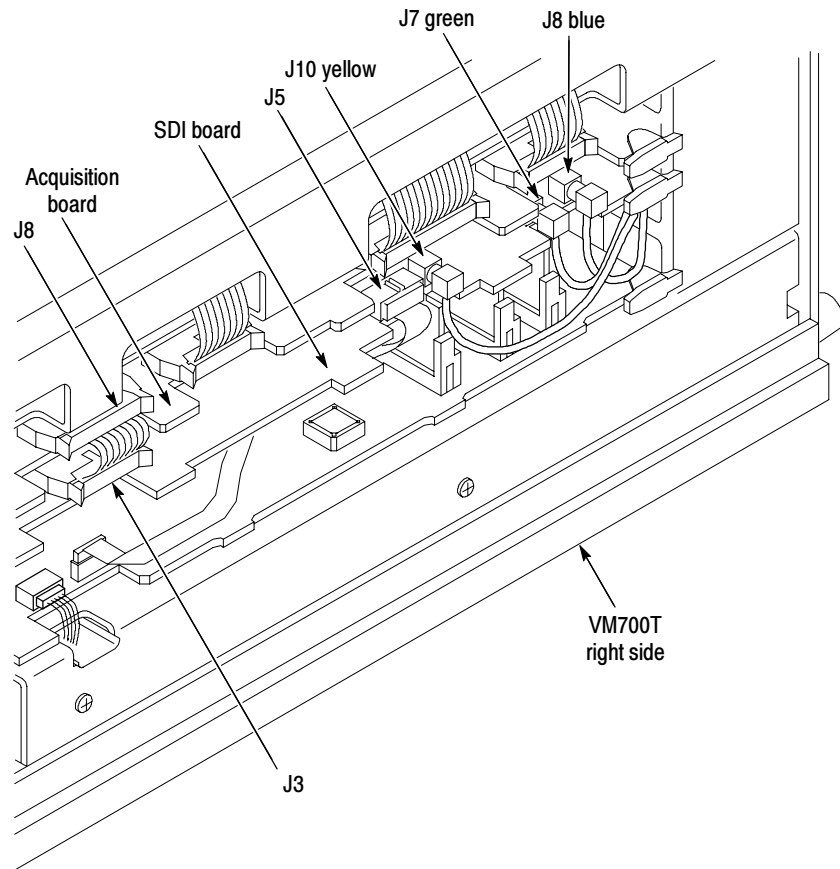

Figure 6-12: SDI board (A22) cable connections

1. Perform the following steps to remove the SDI Rear Panel Interface assembly:
 - a. Remove the right side cover panel (refer to *Cover Panel Removal and Replacement* on page 6-8).
 - b. Remove the card cage retainer (refer to step 1 on page 6-16).
 - c. The SDI board occupies the second from the top slot in the right-side card cage (see Figure 6-10 on page 6-17).
 - d. Disconnect the cables from the SDI board at J8, J7, J10, and J5 (see Figure 6-12).
 - e. Remove the four retaining screws from the SDI Rear Panel Interface assembly (see Figure 6-13).
 - f. Remove the SDI Rear Panel Interface assembly by carefully pulling the four cables out through the hole in the chassis.

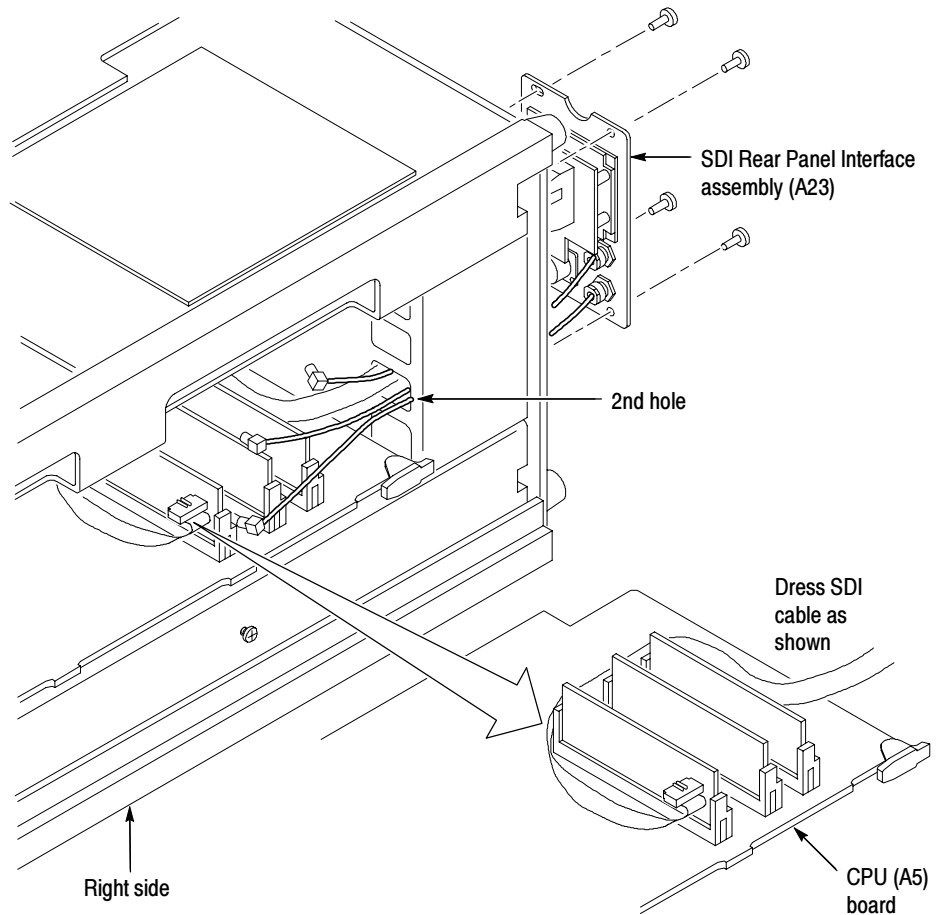

Figure 6- 13: Installing the SDI Rear Panel Interface (A23) assembly

2. Perform the following steps to replace the SDI Rear Panel Interface assembly:
 - a. Position the SDI Rear Panel Interface assembly at the rear of the measurement set. Slide all four cables through the second hole from the bottom on the rear panel as shown in Figure 6-13.
 - b. Secure the SDI Rear Panel Interface assembly to the rear panel using the four retaining screws.
 - c. Slide the CPU (A5) board halfway out of the measurement set.
 - d. Lay the SDI multicolored ribbon cable on the CPU (A5) board as shown in Figure 6-13.
 - e. Reinstall the CPU board.

- f. Plug in the three coaxial cables at J7, J8, and J10. See Figure 6-12 on page 6-21 for the proper cable connections.
- g. Plug in the multicolored ribbon cable at J5.
- h. Install the card cage retainer (refer to step 4 on page 6-17).
- i. Install the cover panel (refer to *Cover Panel Removal and Replacement* on page 6-8).

Analog Input Board Removal and Replacement

Removing and replacing the Analog Input board (A1) consists of removing the top cover, removing four wires and two ribbon cables, and removing the board's retainer screws. With the screws removed, the board may be lifted from the VM700T chassis and set aside. Replacing the board is the reverse of this procedure. You may use the following procedures to remove and replace the analog input board.

Required Tools. Use the following tools to remove the Analog Input circuit board:

- Pozidriv screwdriver, 1X, 2X.

Procedure. Use the following procedure to remove and replace the Analog Input board.

1. Perform the following steps to remove the Analog Input board:
 - a. Remove the top cover panel (refer to *Cover Panel Removal and Replacement* on page 6-8).
 - b. Disconnect the wire at J132 and the shielded cable at J6 and move them aside (see Figure 6-14 for cable locations).
 - c. Disconnect the ribbon cable at J965.
 - d. Disconnect the power bus cable at its five connectors, and then remove the cable.
 - e. Remove the wire connecting A4 J915 to A1 J922 at the J922 end only.
 - f. Remove the wire connecting A4 J418 to A1 J923 at the J923 end only.
 - g. At the back of the instrument remove the screws holding the signal input connector to the instrument rear panel (see Figure 6-15).
 - h. Remove the eight board retaining screws (seven on the perimeter and one in the center) and carefully lift the board from the VM700T chassis.

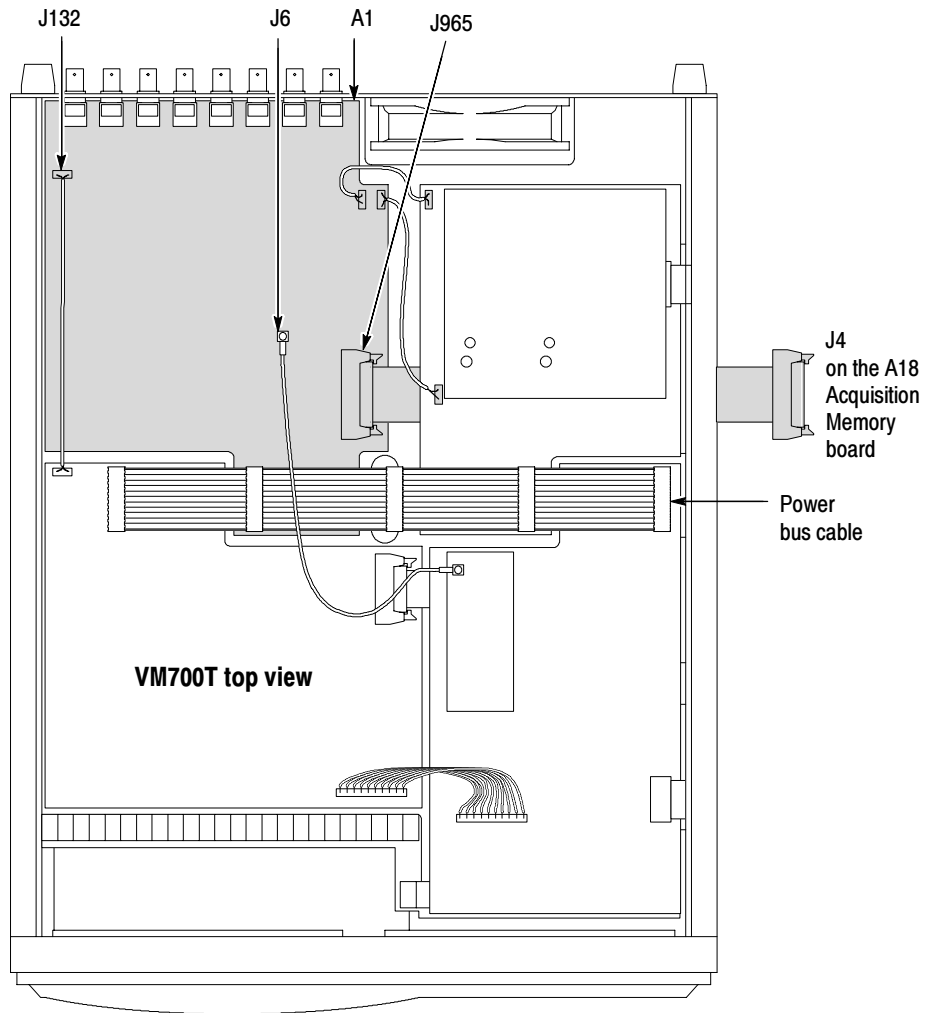

Figure 6- 14: Disconnecting the Analog Input board connectors

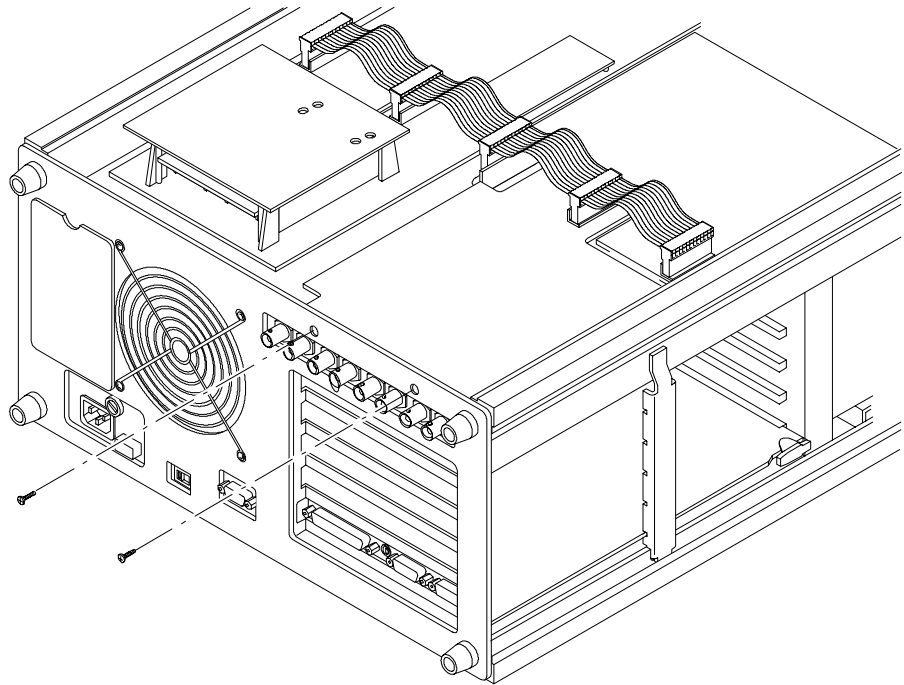

Figure 6-15: Removing screws from the signal input connector plate

2. Perform the following steps to replace the Analog Input board:
 - a. Carefully place the board in the VM700T chassis by guiding the signal input connectors through the slot in the rear panel and positioning the board on its bulkhead standoffs.
 - b. Replace the eight board retaining screws, and then replace the screws holding the signal input connector to the instrument rear panel (see Figure 6-15).
 - c. Connect the ribbon cable at J965 (see Figure 6-14 for cable locations).
 - d. Connect the wire at J132 and the shielded cable at J6.
 - e. Replace the wire connecting A4 J915 to A1 J922.
 - f. Replace the wire connecting A4 J418 to A1 J923.
 - g. Install the power bus cable on its five connectors.
 - h. Install the cover panel (refer to *Cover Panel Removal and Replacement* on page 6-8).

Genlock Board Removal and Replacement

Removing the Genlock board (A2) consists of removing the VM700T top and right-side cover panels, removing the ADC board, disconnecting a flat cable and

a wire, and removing seven screws. With the screws removed the board may be lifted from the VM700T chassis and set aside. See Figure 6-16 for the location of the genlock board. Use the following procedures to remove and replace the Genlock board.

Required Tools. Use the following tools to remove the Genlock circuit board:

- Pozidriv screwdriver, 1X, 2X.

Procedure. Use the following procedure to remove and replace the Genlock board.

1. Perform the following steps to remove the Genlock board:
 - a. Remove the top and right-side cover panels (refer to *Cover Panel Removal and Replacement* on page 6-8).
 - b. Remove the card cage retainer (refer to step 1 on page 6-16).
 - c. Disconnect the flat 10-conductor cable between J111 (on the ADC board) and J6 on the Genlock board (see Figure 6-16).
 - d. Disconnect the power bus cable at its five connectors, and then remove the cable.
 - e. Disconnect the ribbon cable between the Genlock board and the Acquisition Memory board from the Genlock board at J8.
 - f. Disconnect the wire at J10.
 - g. Remove the seven board retaining screws and carefully lift the board from the VM700T chassis.
2. Perform the following steps to replace the Genlock board:
 - a. Place the Genlock board carefully on its hardware standoffs, ensuring that the ribbon cable is positioned with its connector through the slot in the right side of the instrument chassis (see Figure 6-16).
 - b. Install the seven board retaining screws.
 - c. Connect the wire at J10.
 - d. Connect the flat 10-conductor cable between J111 (on the ADC board) and J6.

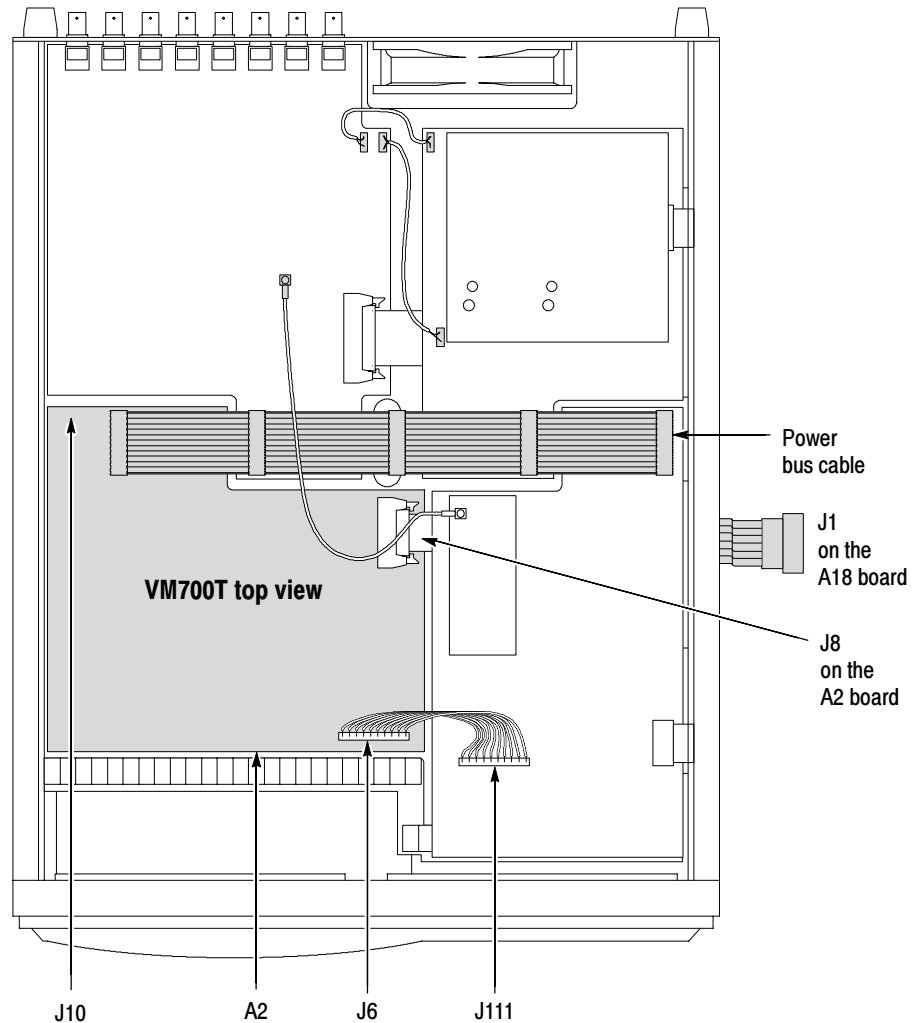

Figure 6-16: Removing the Genlock board

- e. Install the power bus cable at its five connectors.
- f. Connect the interconnection ribbon cable from the Acquisition Memory board to J8 of the Genlock board.
- g. Install the card cage retainer (refer to step 4 on page 6-17).
- h. Install the top and right-side cover panels (refer to *Cover Panel Removal and Replacement* on page 6-8).

ADC Board Removal and Replacement

Removing and replacing the ADC board (A3) consists of removing the instrument top and right-side covers, disconnecting three flat cable assemblies, disconnecting a shielded cable, and removing the screws holding the board in position. With the screws removed the board may be lifted from the VM700T chassis and set aside.

Required Tools. Use the following tools to remove the ADC circuit board:

- Pozidriv screwdriver, 1X, 2X.

Procedure. Use the following procedure to remove and replace the ADC board.

1. Perform the following steps to remove the ADC board:
 - a. Remove the top and right-side cover panels (refer to *Cover Panel Removal and Replacement* on page 6-8).
 - b. Remove the card cage retainer (refer to step 1 on page 6-16).
 - c. Disconnect the flat 10-conductor cable between J111 and J6 (on the Genlock board).
 - d. Disconnect the shielded cable between J765 (located on the ADC Filter board) and J6 on the Analog Input board (see Figure 6-17).
 - e. At the Acquisition Memory board (right side of the instrument), disconnect the cable at J6.
 - f. Disconnect the power bus cable at its five connectors, and then remove the cable.
 - g. Remove the five board retaining screws and carefully lift the board from the VM700T chassis.
2. Perform the following steps to replace the ADC board:
 - a. Carefully place the board in the chassis and onto the bulkhead standoffs (be sure the cable extends out the side of the chassis).
 - b. Install the five board retaining screws.
 - c. Install the cable on its connector at J6 (on the Acquisition Memory board).
 - d. Install the flat 10-conductor cable between J6 (on the Genlock board) and J111.
 - e. Install the shielded cable at J765 (on the ADC Filter board).

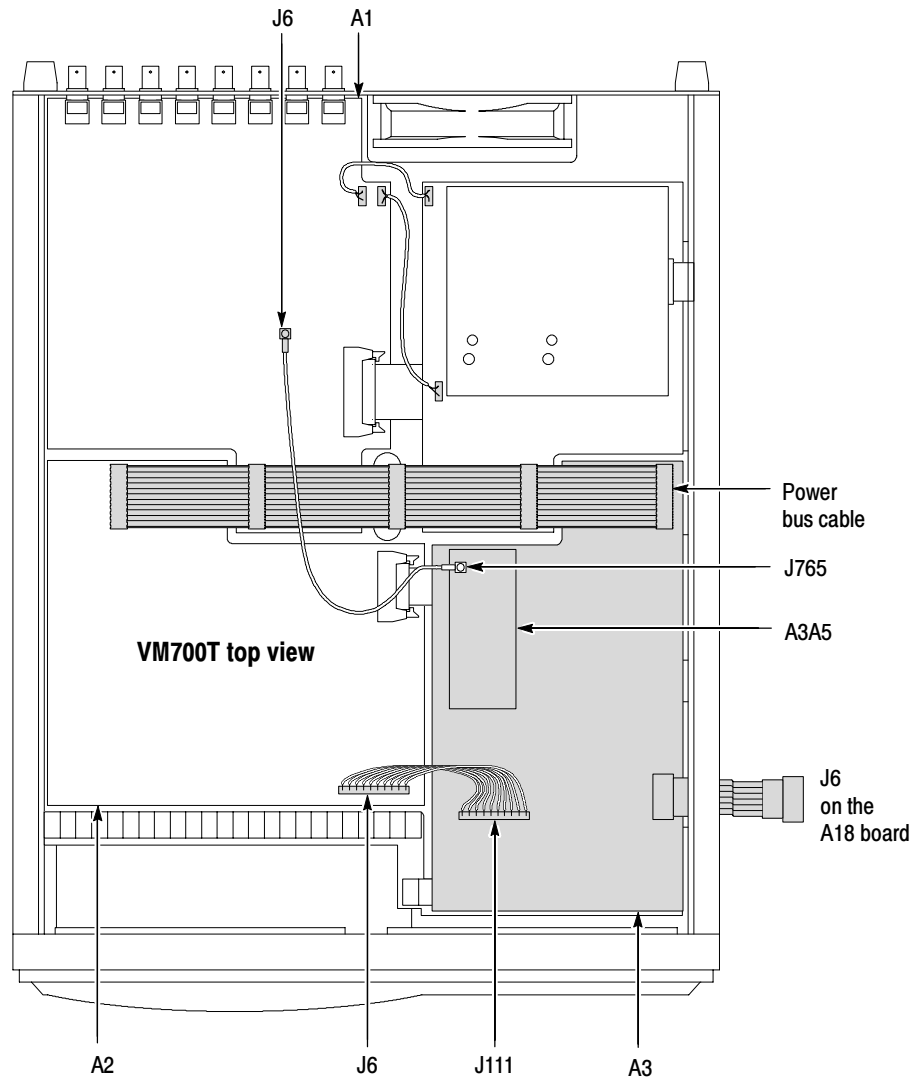

Figure 6-17: Removing the ADC board

- f.** Install the power bus cable at its five connectors.
- g.** Install the card cage retainer (refer to step 4 on page 6-17).
- h.** Install the top and right-side cover panels (refer to *Cover Panel Removal and Replacement* on page 6-8).

**Filter Switch Board
Removal and
Replacement**

Removing and replacing the Filter Switch board (A4) consists of removing the instrument top and right-side covers, removing a flat cable assembly, disconnecting two wires and a cable, and removing the screws holding the board in position. With the screws removed the board may be lifted from the VM700T chassis and set aside. Replacing this board is the reverse of the removal procedure. You may use the following procedures to remove and replace the filter switch board.

Required Tools. Use the following tools to remove the Filter Switch circuit board:

- Pozidriv screwdriver, 1X, 2X.

Procedure. Use the following procedure to remove and replace the Filter Switch board.

1. Perform the following steps to remove the Filter Switch board:
 - a. Remove the top and right-side cover panels (refer to *Cover Panel Removal and Replacement* on page 6-8).
 - b. Remove the card cage retainer (refer to step 1 on page 6-16).
 - c. Disconnect the power bus cable at its five connectors, and then remove the cable (see Figure 6-18).
 - d. Remove the wire connecting A4 J915 to A1 J922 at the J922 end only.
 - e. Remove the wire connecting A4 J418 to A1 J923 at the J923 end only.
 - f. Remove the cable from its connector at J2 on the Acquisition Memory board (A18).
 - g. Remove the five board retaining screws.
 - h. Carefully lift the board from the VM700T chassis and set it aside.
2. Perform the following steps to replace the Filter Switch board:
 - a. If the board has an insulator sheet, hold the it against the board to prevent folding and place the board in the chassis and onto the bulkhead standoffs (be sure the cable extends out the side of the chassis).
 - b. Install the five board retaining screws.
 - c. Install the cable on its connector at J2 (on the Acquisition Memory board).
 - d. Install the power bus cable on its five connectors.

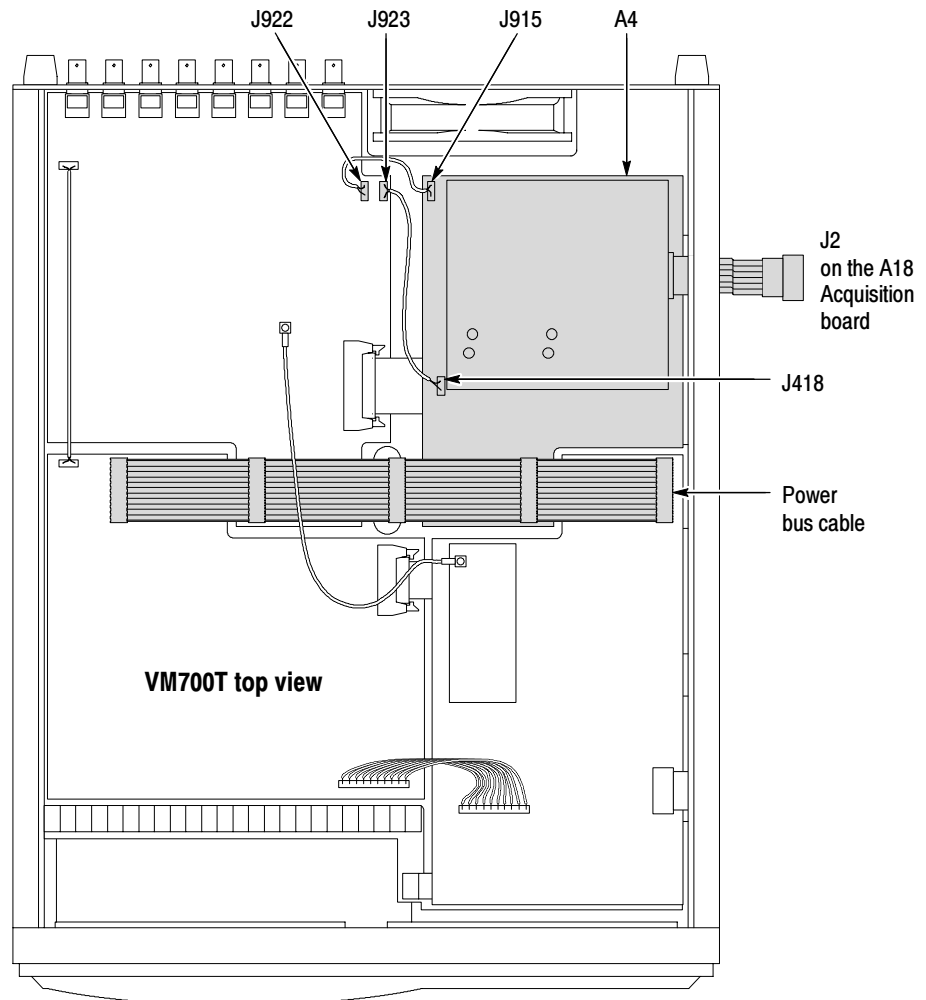

Figure 6-18: Removing the Filter Switch board

- e. Replace the wire connecting A4 J915 to A1 J922.
- f. Replace the wire connecting A4 J418 to A1 J923.
- g. Install the card cage retainer (refer to step 4 on page 6-17).
- h. Install the top and right-side cover panels (refer to *Cover Panel Removal and Replacement* on page 6-8).

Display and Control Components Removal and Replacement

This section describes removing and replacing the VM700T components responsible for instrument display and user interface. These components include the CRT assembly, the touch panel, and the keypad board assembly. Removing and replacing these components requires first removing the instrument cover panels, the CRT bezel, and (to remove the keypad board assembly) the right side card cage retainer.

This section describes removing and replacing the VM700T components responsible for instrument display and user interface. These components include the CRT assembly, the touch panel, and the keypad board assembly. Removing and replacing these components requires first removing the instrument cover panels, the CRT bezel, and (to remove the keypad board assembly) the right side card cage retainer.

Required Tools. Use the following tools to remove the display and control components:

- Flat-blade screwdriver, $\frac{3}{16}$ or $\frac{1}{4}$ inch blade.
- Combination wrench or nut driver, $\frac{3}{16}$ inch.
- Pozidriv screwdriver, 1X, 2X.

CRT Bezel. Use the following procedure to remove and replace the CRT bezel.

1. Perform the following steps to remove CRT bezel:
 - a. Remove the instrument cover panels (refer to *Cover Panel Removal and Replacement* on page 6-8).
 - b. Remove the four screws holding the bezel to the front frame (see Figure 6-19). There is one screw on each side and one each in the top and bottom of the bezel.
 - c. Carefully separate the bezel from the frame and disconnect the 5-conductor cable from the STBY/ON switch.
 - d. Remove the nut that holds the STBY/ON switch ground strap ring terminal to the keyboard bracket and disconnect the ground strap (see Figure 6-20).
2. Replace the CRT bezel by performing step 1 in reverse order.

NOTE. Use care in tightening the bezel retaining screws. The threaded bezel inserts can be stripped from the bezel if the screws are over-tightened.

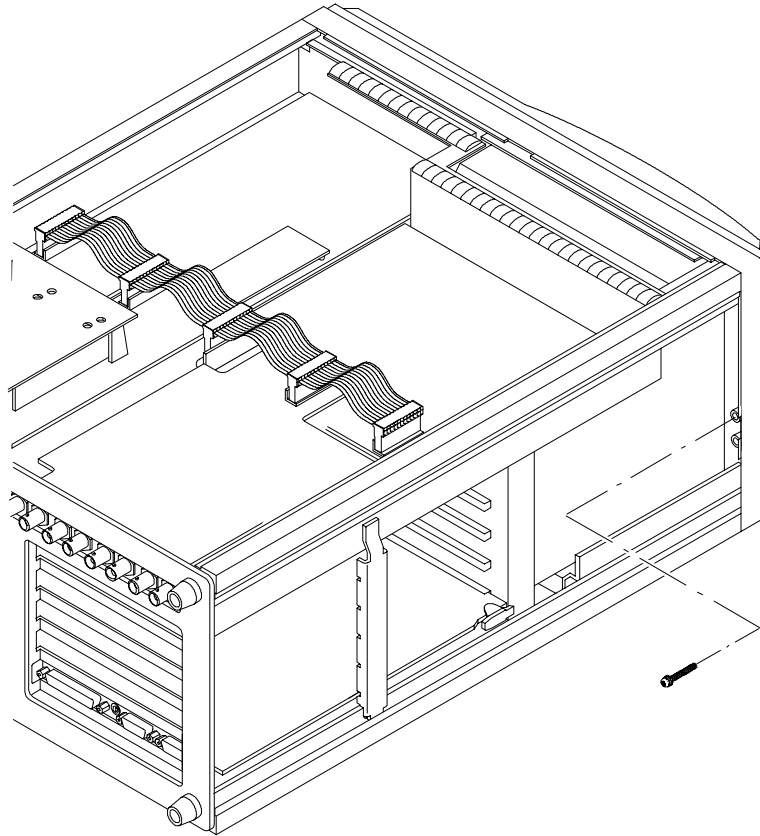

Figure 6-19: Locating the bezel retaining screws

STBY/ON Switch. Use the following procedure to remove and replace the STBY/ON switch.

1. Perform the following steps to remove the STBY/ON switch:
 - a. Remove the CRT bezel (refer to *CRT Bezel* on page 6-32).
 - b. From the circuit side of the STBY/ON switch remove the two nuts holding the switch assembly to the bezel. See Figure 6-20.
 - c. Separate the switch and its front plate from the bezel.
2. Replace the STBY/ON switch by performing step 1 in reverse order.

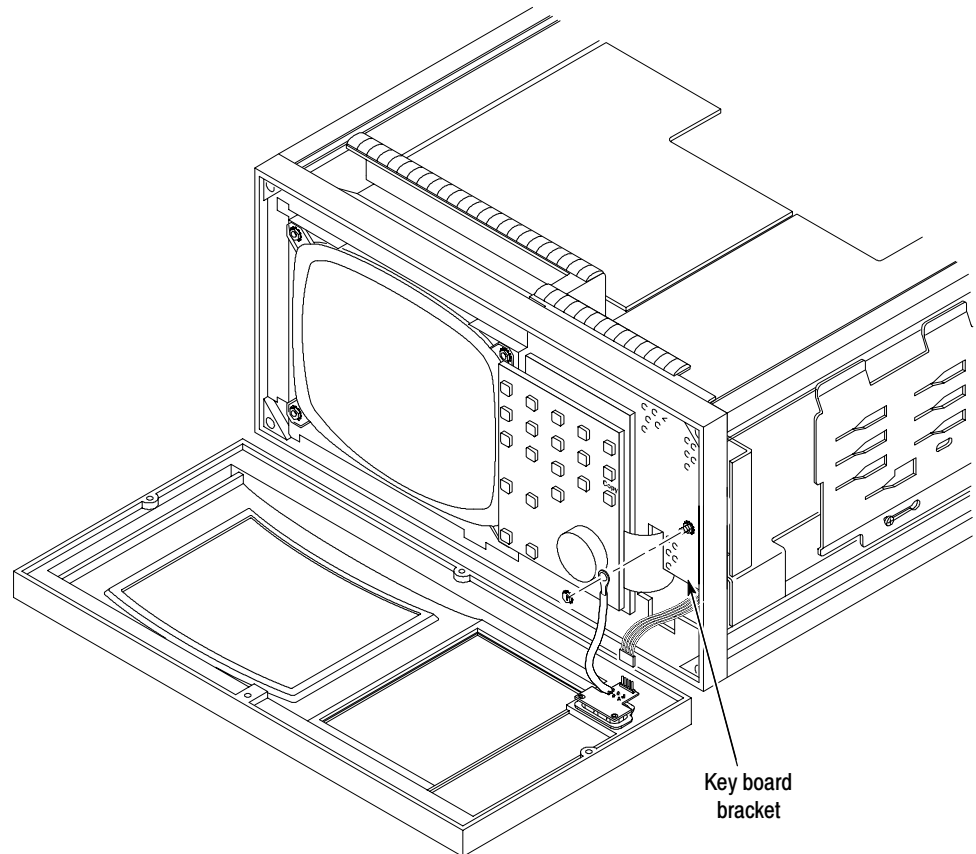

Figure 6-20: Disconnecting the STBY/ON circuit board

Keypad Board Assembly. Use the following procedure to remove and replace the Keypad Board assembly:

1. Perform the following steps to remove the Keypad board assembly:
 - a. Remove the CRT bezel (refer to *CRT Bezel* on page 6-32).
 - b. Remove the right-side card cage retainer (refer to step 1 on page 6-16).
 - c. Disconnect the interconnection cable at J9 on the CPU board.
 - d. Remove the flat-head screws holding the Keypad board assembly bracket to the VM700T front frame (see Figure 6-21).
 - e. Carefully separate the Keypad board assembly from the instrument.
 - f. For instruments with serial numbers B050100 and above, disconnect the Touch Panel cable from the Controller board and disconnect the three-wire RS232 cable from the Controller board. For instruments with serial numbers below B050100, do the following instead: On the back of

the Keypad board assembly, remove the touch panel connector at J933 and the ground wire attached to the standoff to remove the Keypad board assembly.

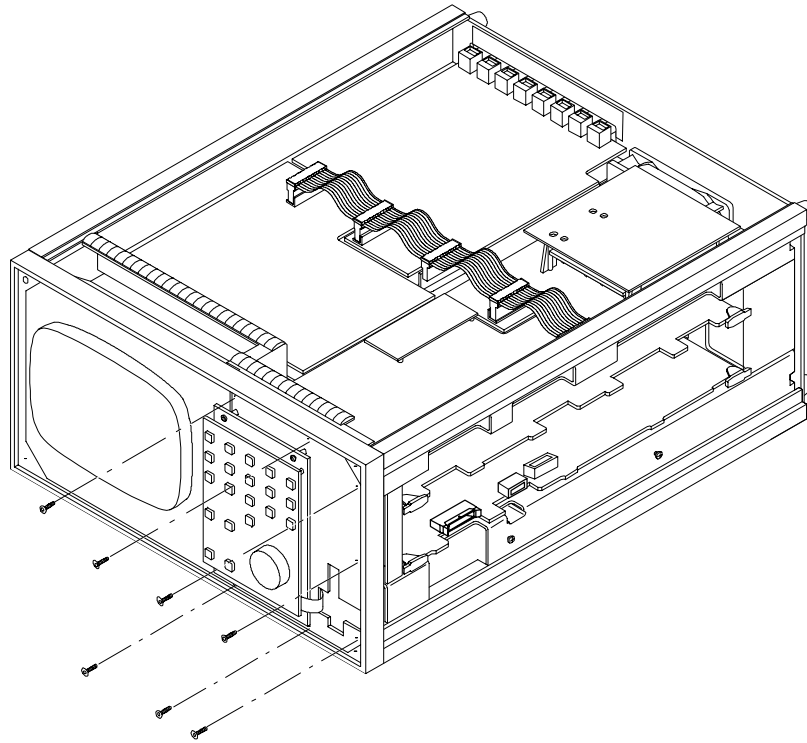

Figure 6-21: Removing the retaining screws from the Keypad board

2. Replace the Keypad board assembly by performing step 1 in reverse order.



CAUTION. For instruments with serial numbers below B050100, you must reinstall connector J933 on the Keypad board assembly. Be sure to orient the connector with its key facing the center of the board (see Figure 6-22). Any other connector orientation is incorrect and can cause component failure when the instrument powers on.

Ground wire at J933 only installed on instruments with serial numbers below B050100.

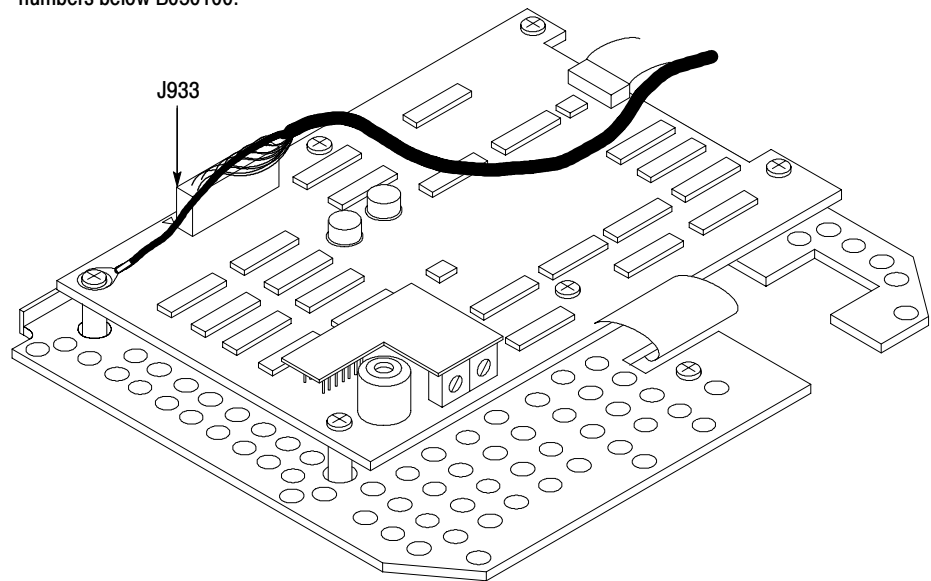

Figure 6-22: Orienting connector J933 for installation on the Keypad board (serial numbers below B050100)

CRT Touch Panel. Use the following procedure to remove and replace the CRT touch panel.

1. Perform the following steps to remove the CRT touch panel:
 - a. Remove the CRT bezel (refer to *CRT Bezel* on page 6-32).
 - b. Remove the Keypad board assembly (refer to *Keypad Board Assembly* on page 6-34).

NOTE. *It is not necessary to remove the ground wire on the Keypad board assembly if you are removing just the CRT or CRT touch panel.*

- c. Remove the four nuts that hold the touch panel, and then lift the CRT touch panel away from the CRT to remove the touch panel (see Figure 6-23).
2. Replace the CRT touch panel by performing step 1 in reverse order.

CRT Assembly. Use the following procedure to remove and replace the CRT assembly.

1. Perform the following steps to remove the CRT assembly:
 - a. Remove the CRT bezel (refer to *CRT Bezel* on page 6-32).
 - b. Remove the right-side card cage retainer (refer to step 1 on page 6-16).
 - c. Remove the Keypad board assembly (refer to *Keypad Board Assembly* on page 6-34).

NOTE. It is not necessary to remove the ground wire on the Keypad board assembly if you are removing just the CRT or CRT touch panel.

- d. Remove the CRT touch panel (refer to the preceding procedure).
- e. Position the instrument on its right side and remove the four screws holding the CRT assembly to the VM700T chassis (see Figure 6-23).

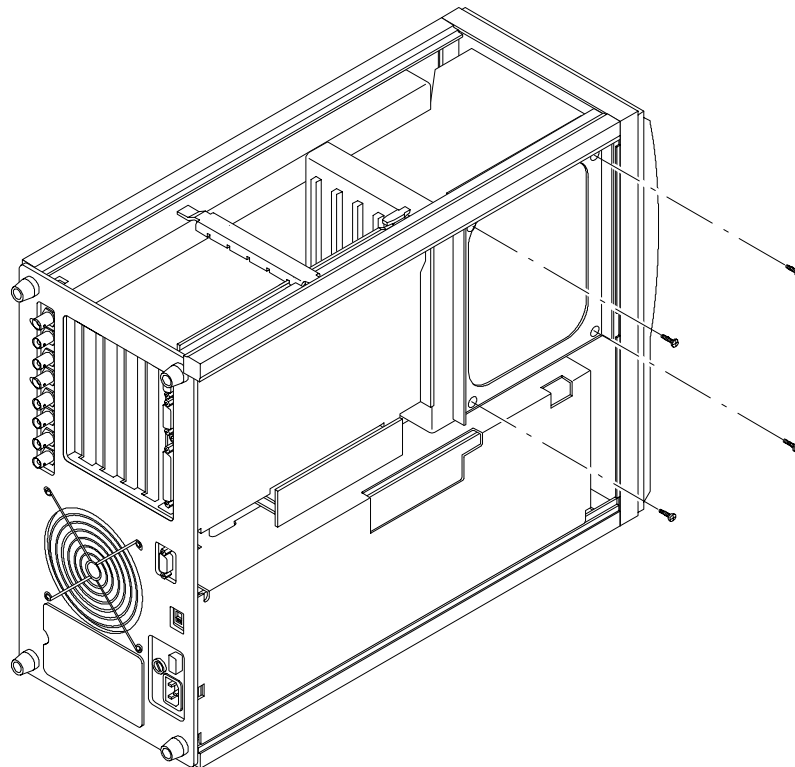

Figure 6-23: Removing the CRT assembly retaining screws

- f. Slide the CRT assembly out of the chassis enough to remove the 10-wire connector at the rear.
 - g. Remove the CRT assembly from the VM700T chassis and set it aside.
2. Replace the CRT touch panel by performing step 1 in reverse order.

**Power Supply,
Interconnect Board,
VGA Board, and Cooling
Fan Removal and
Replacement**

This section describes how to remove and replace the power supply, the main interconnect board, and the cooling fan.

Required Tools. Use the following tools to remove the display and control components:

- Flat-blade screwdriver, $\frac{3}{16}$ or $\frac{1}{4}$ inch blade.
- Pozidriv screwdriver, 2X.
- Combination or open-end wrench, $\frac{11}{32}$ inch.
- Small wire cutters.

Power Supply Module. The power supply module is located on the right side of the VM700T, below the right-side card cage. You may remove the power supply by first removing the cover panels of the VM700T (refer to *Removing and Replacing a Cover Panel* on page 6-8 for more information) and turning the instrument upside down. The following procedure describes removing and replacing the power supply.

NOTE. *The power supply module is field removeable for replacement only; it is not a field-serviceable unit.*

1. Perform the following steps to remove the power supply:
- a. Remove the instrument cover panels (refer to *Cover Panel Removal and Replacement* on page 6-8).
 - b. Position the VM700T with its bottom facing up and remove the wires and connectors from the power supply. Disconnect the wires to the On/Off switch from the switch.

NOTE. *The connections are labeled on the power supply. You should also tag each wire with a label as you remove it, for easy replacement later.*

- c. From the instrument bottom, remove four attaching screws (one screw is accessed through a slot in the power supply housing). See Figure 6-24.

- d. At the rear panel, remove five retaining screws.
- e. Move the power supply to clear the corner rail overhang and, holding the wires aside, carefully lift it straight up and out of the VM700T chassis.
- f. Remove the cable to the On/Off switch from the power supply.

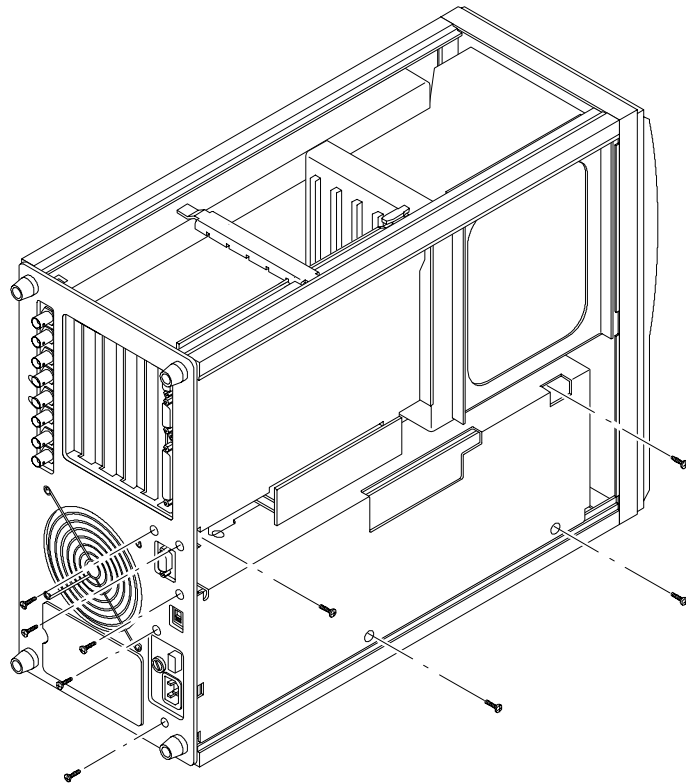

Figure 6-24: Removing the power supply retaining screws

2. Replace the power supply by performing step 1 in reverse order.



CAUTION. When replacing the power supply, make sure the replacement power supply's line voltage switch is set to the correct line voltage. If the line voltage switch is not set correctly the VM700T and the power supply can be severely damaged.

Interconnect Board Assembly (A11). The Interconnect board assembly (A11) consists of three circuit boards assembled with connectors, screws, and spacers. This assembly is replaced as a unit.

All VM700T circuit boards in the two card cages plug into the Interconnect board assembly. Removing and replacing this assembly requires removing the boards from the card cages, removing wires and attaching screws, and lifting the main interconnect assembly from the instrument. The following procedure describes removing and replacing the main interconnect assembly.

1. Perform the following steps to remove the Interconnect board assembly:
 - a. Remove the instrument cover panels (refer to *Cover Panel Removal and Replacement* on page 6-8).
 - b. Remove the CPU board from the right-side card cage (refer to *CPU Board (A5) Removal and Replacement* on page 6-15).
 - c. Remove the Acquisition Memory board (refer to *Acquisition Memory Board (A18) Removal and Replacement* on page 6-18).
 - d. Remove the I/O board (refer to *I/O Board (A20) Removal and Replacement* on page 6-9).
 - e. Remove any installed option boards (refer to *Option 40 and Option 41 Audio Boards (A12, A13, and A17) Removal and Replacement* on page 6-11, and *Option 48 GPIB Interface Board (A19) Removal and Replacement* on page 6-14 for more information).
 - f. From the top of the instrument, disconnect the power bus cable at its five connectors, and then remove the cable.
 - g. From the bottom of the instrument, remove the connectors and terminal wires between the power supply and the Interconnect board assembly.
 - h. Inside the left card cage, remove the six screws holding the Interconnect board assembly to the card cage back panel (see Figure 6-25).

NOTE. *The Interconnect board assembly retaining screws are easier to remove if you first place the instrument on its right side and then use a long-shank screwdriver (allowing more hand clearance) to remove them.*

- i. With the instrument placed upside down, carefully push the power supply wiring aside and move the Interconnect board assembly up and out of the chassis.
2. Replace the Interconnect board assembly by performing step 1 in reverse order.

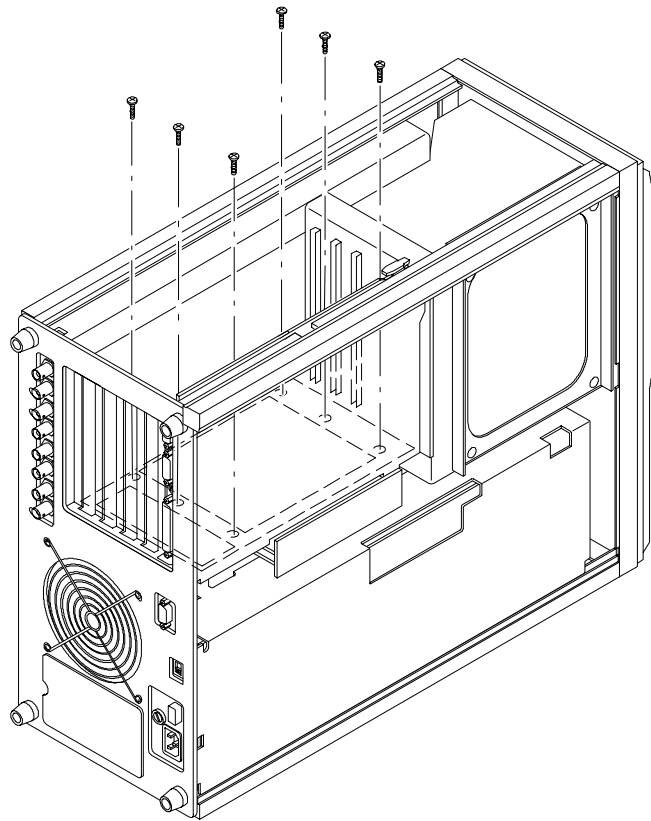

Figure 6-25: Removing the Interconnect board assembly retaining screws

Cooling Fan. To remove and replace the cooling fan, first remove the top and bottom cover panels, the power supply, and the harness retainers that attach the fan's wire harness to the bottom of the left card cage. Next, remove the cooling fan and its guard by removing the retaining screws and nuts.

Use the following steps to remove or replace the cooling fan:

1. Perform the following steps to remove and replace the cooling fan:
 - a. Remove the power supply module (refer to *Power Supply Module* on page 6-38).
 - b. With cutters, remove the plastic retainers holding the fan wire harness to the bottom of the left card cage.
 - c. Disconnect the VGA circuit board connector and separate the interconnection cable from the fan housing.

- d. Remove the screws and nuts holding the cooling fan and separate the fan and its finger guard (SN B029999 and below only) or its EMI filter (SN B030100 and above only or if Option 1S installed) from the back panel. See Figure 6-26.

NOTE. Remove the two screws accessible from the bottom first. Then, turn the instrument right-side up, remove the remaining two screws, and carefully lift the fan clear of the instrument.

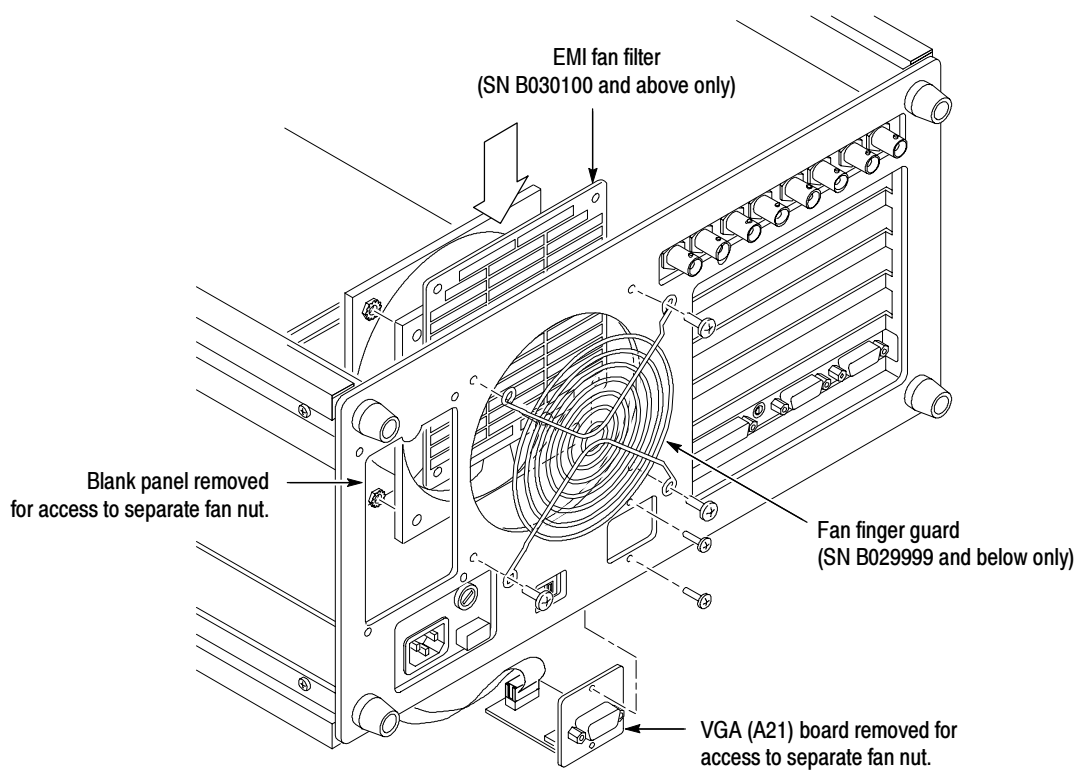

Figure 6- 26: Removing the cooling fan

2. Replace the cooling fan by performing step 1 in reverse order.



CAUTION. Incorrect installation of the fan assembly will result in overheating and possible damage to the measurement set.

NOTE. Reinstall plastic retainers to hold the fan wire harness to the bottom of the left card cage. Reconnect the VGA cable to the fan housing with a cable tie. When reinstalling the fan, make sure you have the fan positioned so that the air flow is out of the VM700T.

VGA Connector Board. Use the following procedure to remove and replace the VGA Connector board.

1. Perform the following steps to remove the VGA Connector board:
 - a. Remove the instrument cover panels (refer to *Cover Panel Removal and Replacement* on page 6-8).
 - b. Remove the attaching hardware for the VGA Connector board from the rear of the VM700T (see Figure 6-26).
 - c. Pull the VGA Connector circuit board away from the fan housing and disconnect the VGA ribbon cable from the connector on the rear of the VGA Connector board.
 - d. Remove the VGA Connector board from the VM700T.
2. Perform the following steps to replace the VGA Connector board:
 - a. Reconnect the VGA ribbon cable to the connector on the circuit board.
 - b. Position the VGA Connector board on the mounting plate against the inside surface of the rear panel under the fan housing.
 - c. Align the holes in the circuit board with the holes in the rear panel mounting plate, and install and tighten the attaching hardware.
 - d. Replace the cover panels (refer to *Cover Panel Removal and Replacement* on page 6-8).

VM700T Rack Mounting Instructions

Unpackaging When unpackaging the VM700T Video Measurement Set for installation, keep the shipping carton and packaging material. If returning the VM700T for repairs should become necessary, you will then have packaging available that will provide adequate protection for shipment.

Power Requirements The VM700T will operate with line frequencies of 50 Hz or 60 Hz, over two line voltage ranges. The low voltage range is from 90 VAC to 132 VAC; 115 VAC nominal. The high voltage range is from 180 VAC to 250 VAC; 230 VAC nominal.



WARNING. For your protection and to avoid damage to the measurement set, shut the power off before removing or replacing any circuit boards, connectors, or jumpers.

Changing the Line Voltage Range and Fuse

The voltage range selection switch and fuse holder are located on the lower left corner of the rear panel of the VM700T.

The VM700T is shipped from the factory set for 115 VAC operation. If this setting must be changed to 230 VAC, simply set the voltage range selection switch to the 230 V position to operate in the high voltage range. The 6 A slow-blow fuse provides the proper protection in the low voltage range and must be replaced with a 3 A slow-blow fuse for operation in the high voltage range.

NOTE. If you wish to use Password protection for your user-definable configuration, DIP switch settings on the A5 CPU board must be changed. Refer to the VM700T Option 01 (NTSC) and Option 11 (PAL) User Manual, Configuring the VM700T, for a detailed description of how Password operates.

Rack Mounting

The VM700T fits in a standard 19-inch rack and is shipped with the necessary hardware for rack mounting. Spacing between the front rails of the rack must be at least 17-3/4 inches to allow clearance for the rack slides.

Rack slides conveniently mount in any rack that has a front-to-rear rail spacing between 15-1/2 and 28 inches. Six inches of clearance between the rear panel of the VM700T and the rear rack panel is required for connector space and to provide adequate air circulation.

The rack slides consist of two assemblies, one for each side of the rack. Each assembly consists of three sections, as shown in Figure 6-27. The stationary section of each rack slide attaches to the rack rails. The chassis section mounts on the VM700T and is installed at the factory. The chassis section slides into the intermediate section, which in turn slides into the stationary section.

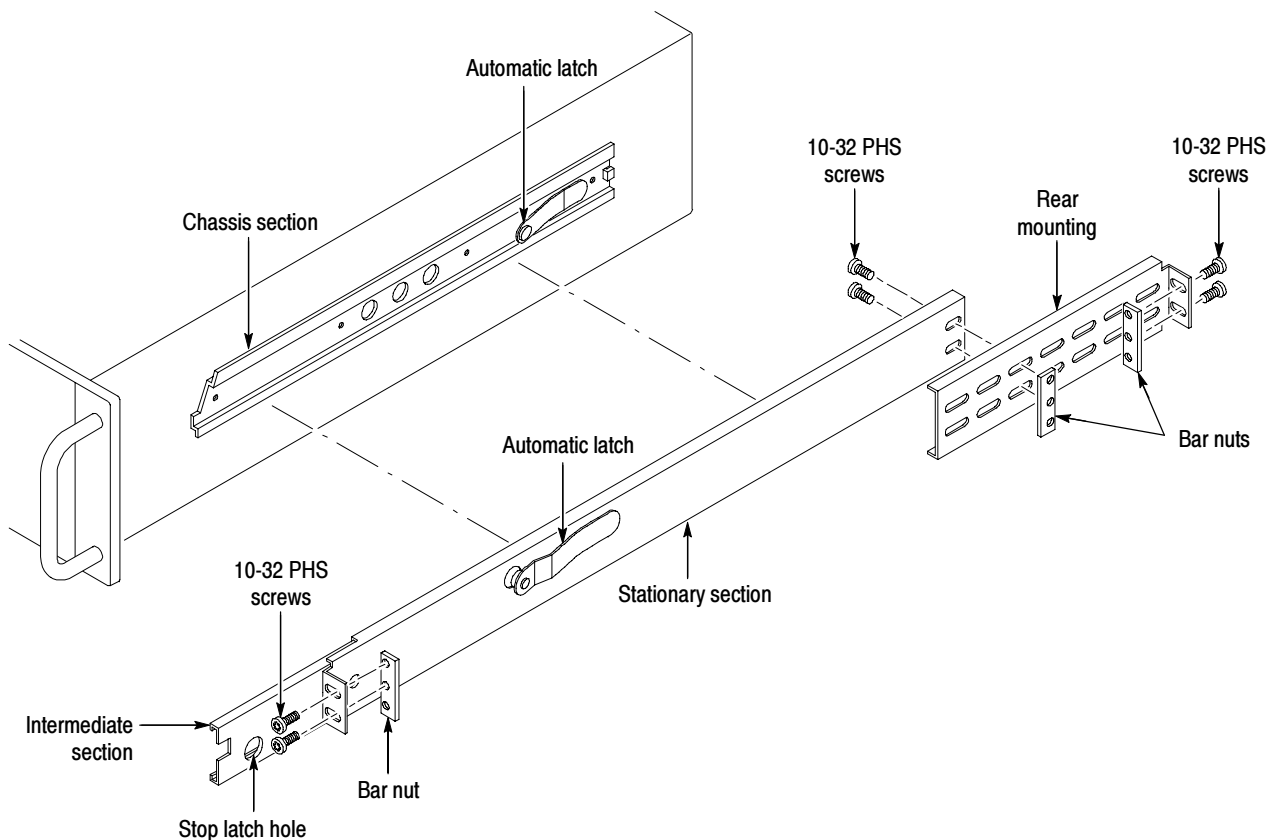

Figure 6-27: Construction of rack slides

Mounting the Rack Slides

Locate the proper holes in the rack rails as shown in Figure 6-28. Notice that the hole spacing varies with the type of rack. When installing the slides in EIA-type racks, make certain that the slides are attached to the 1/2inch-spaced holes. Install the stationary section of the rack slides as shown in Figure 6-29. Make sure the stationary sections are horizontally aligned, level and parallel.

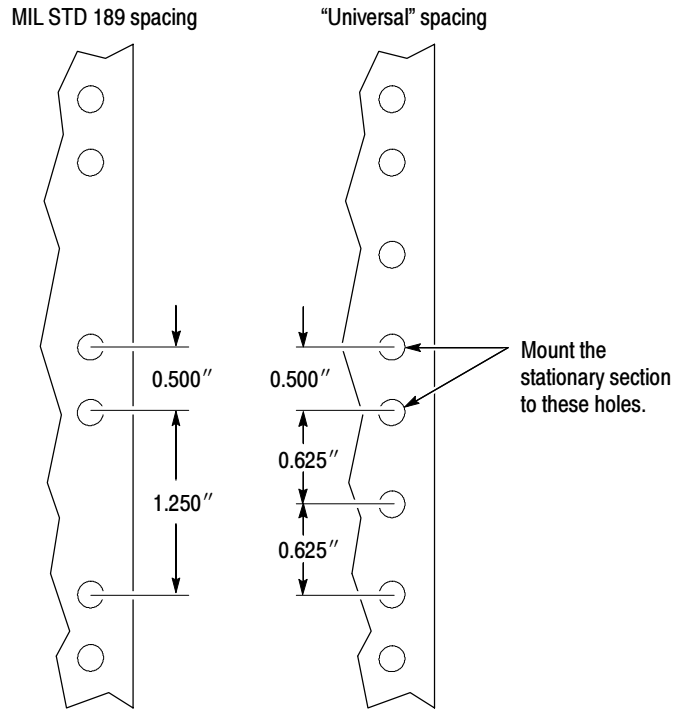

Figure 6-28: Rail detail for mounting rack slides

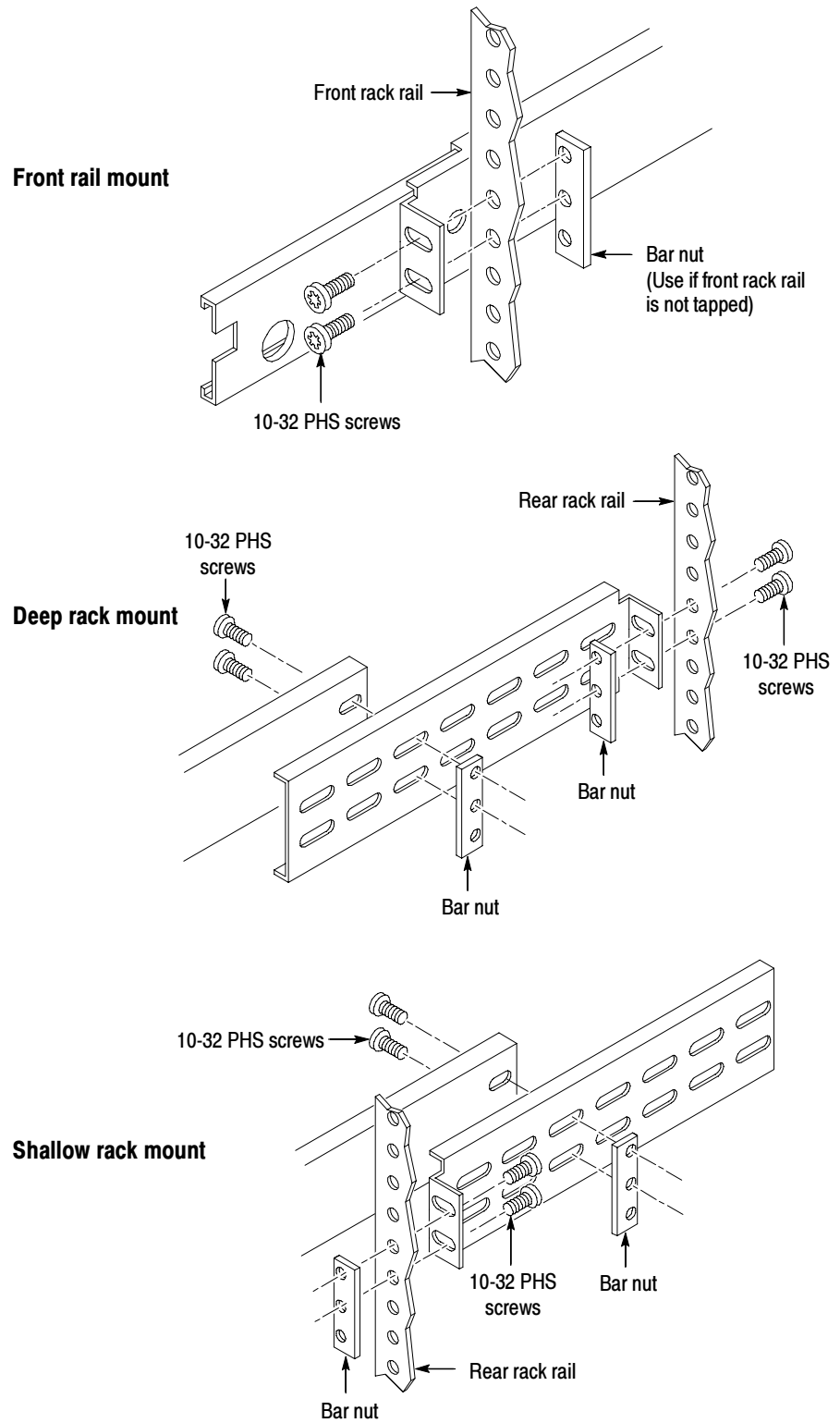

Figure 6-29: Mounting stationary rack sections

Installation/Removal from the Rack

Figure 6-30 shows how to install and remove the instrument from the rack.

Rack Adjustments

After installation, the rack slides may bind if they are not properly adjusted. To adjust the slides, slide the instrument out about 10 inches, slightly loosen the screws holding the slides to the front rails, and allow them to seek an unbound position.

Re-tighten the screws and check the tracks for smooth operation by sliding the instrument in and out of the rack several times.

To fasten the instrument securely in the rack, tighten the knurled retaining screw.

Rack Slide Maintenance

The rack slides do not require lubrication. The dark gray finish on the rack slides is a permanent, lubricated coating.

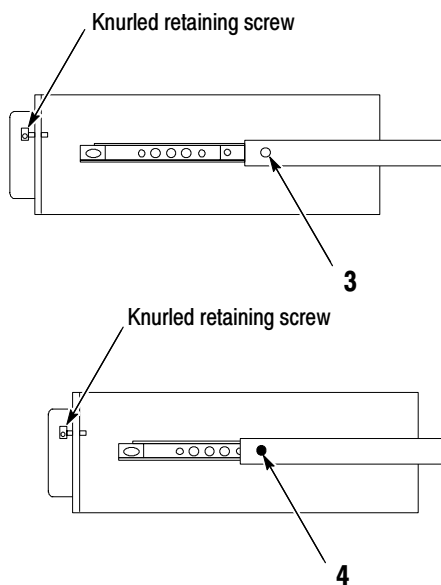

To install:

1. Pull the intermediate track sections to the fully extended position.
2. Insert the instrument chassis sections into the intermediate sections.
3. Press the stop latches and push the instrument toward the rack until the latches snap into the holes.
4. Again press the stop latches and push the instrument fully into the rack.
5. Tighten the knurled retaining screw.

To remove:

1. Loosen the retaining screw and pull the instrument outward until the stop latches snap into the holes.
2. Press the stop latches and remove the instrument.

Figure 6-30: Installing and removing the VM700T from the rack

Troubleshooting Procedures

The troubleshooting material provided in this section is general and is not intended to cover specific instrument malfunctions. This section contains the following subsections:

- Troubleshooting techniques page 6-50
- Isolating operational faults page 6-51
- Diagnostics page 6-55
 - Low level diagnostics page 6-59
 - Diagnostic utilities page 6-65
 - Calibrating the touch screen page 6-68
 - Setting the power-up mode page 6-70
 - VM700T boot switch and diagnostic LED page 6-73
 - Running the high-level diagnostics page 6-74
 - Auto reset (running all diagnostics) page 6-84
 - Viewing stored diagnostic information page 6-84
 - Viewing diagnostics remotely page 6-85
- Troubleshooting the power supply and the CRT display page 6-90
- Troubleshooting Option 40 and Option 41 (Audio) page 6-95
- Troubleshooting Option 48 (GPIB) page 6-99
- Troubleshooting Option 1S (SDI) page 6-100

More Information. The following useful troubleshooting information can be found elsewhere in this manual:

- Refer to *Theory of Operation* on page 3-1 for descriptions of the electrical operation of the VM700T Video Measurement Set from a functional-circuit block perspective.
- Refer to *Diagrams* on page 9-1 for an instrument-level block diagram and interconnection diagram.
- Refer to *Replaceable Mechanical Parts* on page 10-1 for the list of replaceable parts accompanied by exploded view drawings of the instrument.

Troubleshooting Techniques

The following procedure is designed to assist in isolating problems, which in turn expedites repairs and minimizes down time.

1. Ensure that the malfunction actually exists. This is done by running the diagnostics to ensure that the instrument is operating as intended by Tektronix. Refer to *Diagnostics* beginning on page 6-55 for a description of the diagnostic tests and information on using diagnostics for troubleshooting module problems.
2. Determine and evaluate all trouble symptoms. This is accomplished by isolating the problem to a general area such as a replaceable module.



CAUTION. Use extreme care when probing with meter leads or probes, because of the high component density and limited access within the instrument. The inadvertent movement of leads or a probe could cause a short circuit or transient voltage capable of destroying components.

3. Determine the nature of the problem. Attempt to make the determination of whether the instrument is out of calibration or if there has been a component failure. Once the type of failure has been determined, identify the functional area most likely at fault.
4. Visually inspect the suspect assembly for obvious defects. Most commonly these will be broken or loose components, improperly seated components, overheated or burned components, chafed insulation, etc. In the case of overheated components, determine the cause of overheating and correct the cause before reapplying power.
5. Remove defective modules and exchange them with the factory. Refer to *Removal and Replacement Instructions* on page 6-6. Refer also to *Customer Service* on page 6-3 for information on the board exchange repair service.



WARNING. High voltages are present inside the VM700T chassis. These voltages can cause serious injury. Leave all service procedures that require removing instrument covers to qualified service personnel.

Troubleshooting the VM700T is a matter of following a logical series of steps that isolate a problem to a specific system module such as a circuit board, power supply, or display monitor. After isolating the problem, repair consists of replacing the faulty module and checking the instrument for correct operation.

Some VM700T faults can be isolated to just one system module. Correcting these faults requires replacing the faulty module. Other faults may be caused by one or more defective system modules. In either case, the VM700T diagnostics routines can assist in isolating the fault to field-replaceable modules. These routines can also evaluate each of the instrument's major hardware components to provide a high degree of confidence that measurement results produced by the instrument are correct.

The best way to repair multiple-module faults is to replace one module at a time, checking for correct operation after each replacement, until you have located and replaced the faulty module.

Interconnecting Cables. Signals and power supply voltages are passed through the instrument by a system of interconnecting cables. The connector holders on these cables have numbers that identify terminal connectors. A triangular key symbol is used to identify pin 1 on the circuit board to assist in aligning the correct pins on the mating connector.

Isolating Operational Faults

This section presents a series of operational fault symptoms and suggests corrective actions. The most efficient way to use the information involves a two-step approach.

1. Compare the failure symptoms you are experiencing with the symptoms presented in Table 6-3.
2. Run the VM700T built-in diagnostics routines to assist in isolating the failure.

Following these steps will assist you in isolating any VM700T fault to a field-replaceable module such as a circuit board.

For information on how to return defective instrument modules to Tektronix for repair, refer to *Customer Service* on page 6-3.

Table 6-3 lists a series of instrument faults or failures, related possible causes, and suggested corrective actions. Run the complete set of diagnostic test to determine if suspected modules pass or fail the testing before attempting any module exchanges. You can use the information in the table, along with the results of the diagnostic tests, to characterize faulty VM700T operation as a repair guide.

Table 6-3: VM700T symptoms and corrective actions

Symptom	Possible cause	Corrective action
No display (blank screen)	Faulty power supply	Check power supply. Refer to <i>Troubleshooting the Power Supply</i> .
	Faulty CRT	Connect a VGA monitor to the rear panel VGA connector and check for a display. If the VGA signal is good, replace the CRT display assembly. Refer to <i>Removing and Replacing the CRT Assembly</i> .
	Loose Cables	Check for loose AC line cord, CRT connector, or power supply connections. To gain access to the CRT connector, refer to <i>Removing and Replacing the CRT Assembly</i> . To gain access to power supply connections, refer to <i>Removing and Replacing the Power Supply</i> .
	Blown mains (line) fuse	Check fuse on rear panel. Refer to <i>Troubleshooting the Power Supply</i> .
	Faulty CPU board (A5)	Check the CPU board Diagnostic LED. Refer to the diagnostic LED display on page 6-73. Replace the CPU board. Refer <i>Removing and Replacing the CPU Board</i> . (This action requires a complete reprogramming for the replacement CPU.)
Glitches and spikes in Waveform mode	Faulty ADC board (A3)	Replace ADC board. Refer to <i>Removing and Replacing the ADC Board</i> .
	Faulty acquisition memory board (A18)	Replace the acquisition memory board. Refer to <i>Removing and Replacing the Acquisition Memory Board</i> .
	Faulty analog input board (A1)	Replace the analog input board. Refer to <i>Removing and Replacing the Analog Input Board</i> .
VM700T displays the re-initializing message or hangs	Faulty genlock board (A2)	Replace the genlock board. Refer to <i>Removing and Replacing the Genlock Board</i> .
	Faulty ADC board (A3)	Replace the ADC board. Refer to <i>Removing and Replacing the ADC Board</i> .
	Faulty acquisition memory (A18)	Replace the acquisition memory board. Refer to <i>Removing and Replacing the Acquisition Memory Board</i> .
	Faulty Flash SIMM on the CPU board.	Replace the Flash SIMM on the CPU board. (This will require a complete reprogramming of the CPU board.)
	Faulty memory on the CPU board	Replace the memory SIMM on the CPU board.
	Faulty CRT touch panel	Replace the CRT touch panel. Refer to <i>Removing and Replacing the CRT Touch Panel</i> .
	Faulty front panel (A10A1) or keypad board (A10A2)	Replace front panel/keypad board assembly. Refer to <i>Removing and Replacing the Keypad Board</i> .

Table 6-3: VM700T symptoms and corrective actions (cont.)

Symptom	Possible cause	Corrective action
CRT touch panel not operating	Touch panel out of calibration	Try to calibrate the touch panel.
	Faulty CRT touch panel or cabling	Replace the CRT touch panel. Refer to <i>Removing and Replacing the CRT Touch Panel</i> .
	Loose connections	Check connections on back of front panel board. Refer to <i>Removing and Replacing the CRT Touch Panel</i> .
	Faulty front panel (A10A1) or keypad board (A10A2)	Replace the front panel/keypad board assembly. Refer to <i>Removing and Replacing the Keypad Board</i> .
	Faulty display memory module or CPU board.	Replace the display memory module on the CPU board. Replace the CPU board (for bad display memory circuit).
	Faulty touch panel controller board (instruments with serial numbers B050100 and above only).	Replace the touch panel controller board.
Noise at fixed intervals in Line Spectrum mode	Faulty acquisition memory board (A18)	Replace the acquisition memory board. Refer to <i>Removing and Replacing the Acquisition Memory Board</i> .
RAM test failure	Faulty RAM memory modules on the CPU board	Replace the RAM memory SIMM on the CPU board.
	Faulty SIMM board socket	Clean the SIMM board connector. Check for firm connection.
Analog gain out of specification	Faulty ADC board (A3)	Replace the ADC board. Refer to <i>Removing and Replacing the ADC Board</i> .
	Faulty analog input board (A1)	Replace analog input board. Refer to <i>Removing and Replacing the Analog Input Board</i> .
OVERTEMP status LED lit	Faulty power supply	Check power supply. Refer to <i>Power Supply Diagnostics</i> in this section.
	Faulty or blocked cooling fan	Check cooling fan for operation and for obstructions blocking air flow.
	Loose connections to cooling fan	Check cooling fan connections. Refer to <i>Removing and Replacing the Cooling Fan</i> .
	Clogged or dirty front bezel air filters	Clean the front bezel air filters. Refer to <i>Cleaning the Front Bezel Air Filters</i> .
POWER/FAIL Status LED lit	Power supply is in “over temperature shutdown mode”	Same as OVERTEMP symptom.
	Faulty monitor pulling down 12 V on power supply	Diagnose by disconnecting 12 V monitor supply cable (P3) at power supply and retrying startup. If POWER/FAIL status LED does not light with 12 V cable disconnected, replace CRT module.
	Faulty power supply	Check power supply. Refer to <i>Power Supply Diagnostics</i> in this section.

Table 6-3: VM700T symptoms and corrective actions (cont.)

Symptom	Possible cause	Corrective action
	Load on power supply exceeds design limit	Check power supply. Refer to <i>Power Supply Diagnostics</i> in this section.
No waveform display, or a "Loss of Sync" message in waveform mode	Loose cable connections	Check cable connections.
	Incorrect input signal (incorrect H sync or V sync signal)	Verify that horizontal and vertical sync signals are being sent.
	Signal too noisy (signal/noise ratio below required minimum)	Correct the cause of low S/N ratio signal.
	Incorrect sync source selected	Select correct sync source.
	Faulty genlock board (A2)	Replace the genlock board. Refer to <i>Removing and Replacing the Genlock Board</i> .
	Faulty acquisition memory board (A18)	Replace the acquisition memory board. Refer to <i>Removing and Replacing the Acquisition Memory Board</i> .
	Faulty analog input board (A1)	Replace analog input board. Refer to <i>Removing and Replacing the Analog Input Board</i> .
Screen brightness does not adjust	Faulty CRT display module	Replace the CRT module. Refer to <i>Removing and Replacing the CRT Display</i> .
	Faulty front panel (A10A1) or keypad board (A10A2)	Replace the front panel/keypad board assembly (A10). Refer to <i>Removing and Replacing the Keypad Board assembly</i> .
	Faulty display memory SIMM on the CPU board	Replace the display memory SIMM on the CPU board.
	Fault display memory circuit on the CPU board	Replace the CPU board. (This action requires a complete reprogramming for the replacement CPU board.)
No GPIB Operation	Bad or loose GPIB cable	Check GPIB cable connection. Replace the GPIB cable.
	No controller or incorrect controller configuration	Check for correct controller operation.
	Faulty GPIB Interface board	Replace the GPIB interface board.
No RS232 Operation	Incorrect RS-232 cable	Check for correct cable and port connection.
	Incorrect communication parameters	Check for correct parameters in Communication Configuration file.
	Faulty I/O board	Replace the I/O board.

Diagnostics

Diagnostics in the VM700T Video Measurement Set are divided into two sets, low level and high level. The distinction between the two types is based upon the operating system; those diagnostics that run before the instrument's operating system is booted are referred to as low level; those that run as applications executed by the operating system are referred to as high level. The instrument pauses noticeably when the operating system is booting, so messages are displayed indicating when this boot is occurring to aid the user in differentiating between high-level and low-level diagnostics.

Grouping of diagnostics within the two sets is by circuit board. Within a circuit board diagnostic are one or more tests; associated with each test is a main pass/fail result and, where applicable, one or more sub-results. The purpose of this format is to present all the information used within a test to determine its ultimate pass/fail status. There is another diagnostic tests grouping, the Overall Run mode. The three choices are: Power Up mode, Auto Reset mode, and User-Interactive mode. These are discussed later in this section in *Selecting an Overall Run Mode* on page 6-61.

Diagnostics are normally bypassed for a quicker startup but they can be configured to run automatically during a normal instrument powerup. The normal powerup mode skips all diagnostics. Power-up modes can be selected using hardware boot switch settings on the CPU board (discussed later in this section) or, in some cases, by pressing and holding certain front-panel buttons during powerup (referred to as 'backdoor boot modes'). For example, holding the Menu button in while turning on the power causes the VM700T to enter the low-level diagnostic interface.

Interactive diagnostics provide the service person choices to control the tests that run and the manner in which they run. In the user interactive mode, any or all tests within a group of tests can be selected for execution.

Diagnostics displays can be routed to one of the instrument serial ports for viewing on a terminal. This is useful if a malfunction does not permit the testing progress and results to be displayed on the VM700T CRT. A special setting of the boot switch is used to route the diagnostic test displays to the serial ports.

NOTE. *Diagnostics can also be controlled and executed remotely through the serial port. This method is most useful if the display system is inoperative or in a service environment for programmed troubleshooting of the VM700T. Refer to Viewing Diagnostics Remotely on page 6-85 for more information.*

During execution, diagnostics give positive feedback of progress, indicating results as they are gathered. During power-up execution, these results are presented in minimal fashion; a test which passes shows only its main result, whereas one that fails also shows the sub-results that caused the failure. During looping and user-interactive modes, results display options are available to either show only the main test results or all the test results.

To facilitate quick appraisal of diagnostics results, the information is presented in a uniform format. Each line consist of fields arranged under a heading shown at the top of the instrument/terminal screen. The heading line looks something like the following:

“Test____measmt____unit____min____max____result”.

A brief description of the content of each field follows:

Field	Description
Test	In a main result, the name of the test. In a sub-result, noted by an indentation from the associated main result, a description of what was evaluated to determine the main result.
measmt	A measured value, presented in integer, hexadecimal, or engineering scientific notation. If a value is not appropriate, the field is filled with one of the following: “_” no value “<” underrange indicator “>” overrange indicator
unit	Where appropriate, a description of the units of the measured value; otherwise, filler chars.
min	The minimum acceptable value for a passing result.
max	The maximum acceptable value for a passing result.
result	In general, -Pass- or *FAIL*. It can also be one of the following: --NA-- not applicable *?*not tested

Because a rigidly formatted output excludes much useful information, any main or sub-result line can have associated with it one or more lines of indented commentary. Whereas sub-result lines are indented one level of indentation from their associated main results, comments will be indented two levels from their associated main results, whether they are actually associated with the main result or the sub-result.

Diagnostics Menu Overview. An overview of the VM700T Diagnostics Menus is shown in Figure 6-31 and Figure 6-32. Figure 6-31 illustrates the various configuration menus and utilities that are available in the diagnostics routines. Figure 6-32 illustrates the low-level diagnostic tests and the various configuration menus for setting up and running the diagnostic tests.

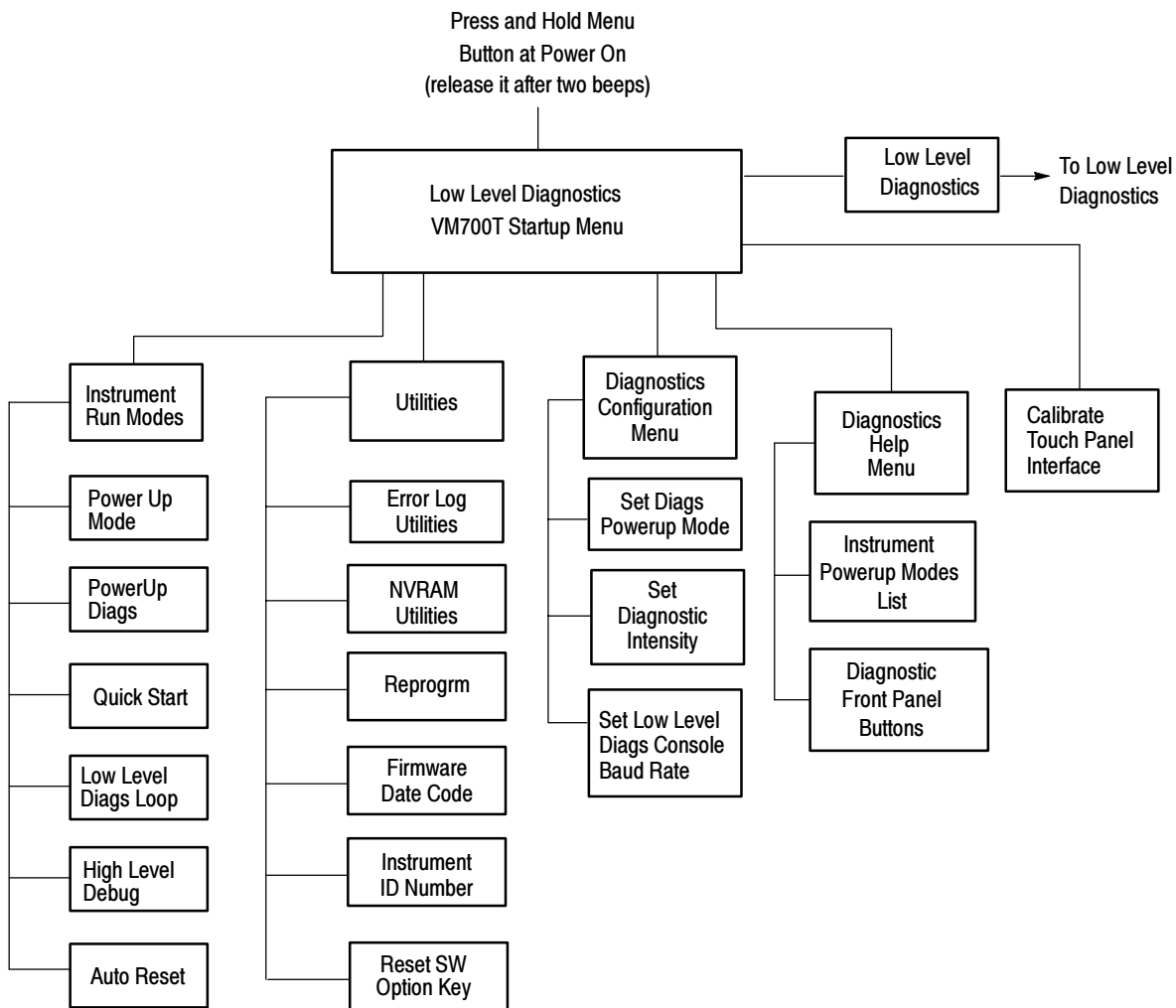

Use Abort or press the Auto button to back up the tree to the VM700T Startup Menu

Figure 6-31: VM700T diagnostics menus overview

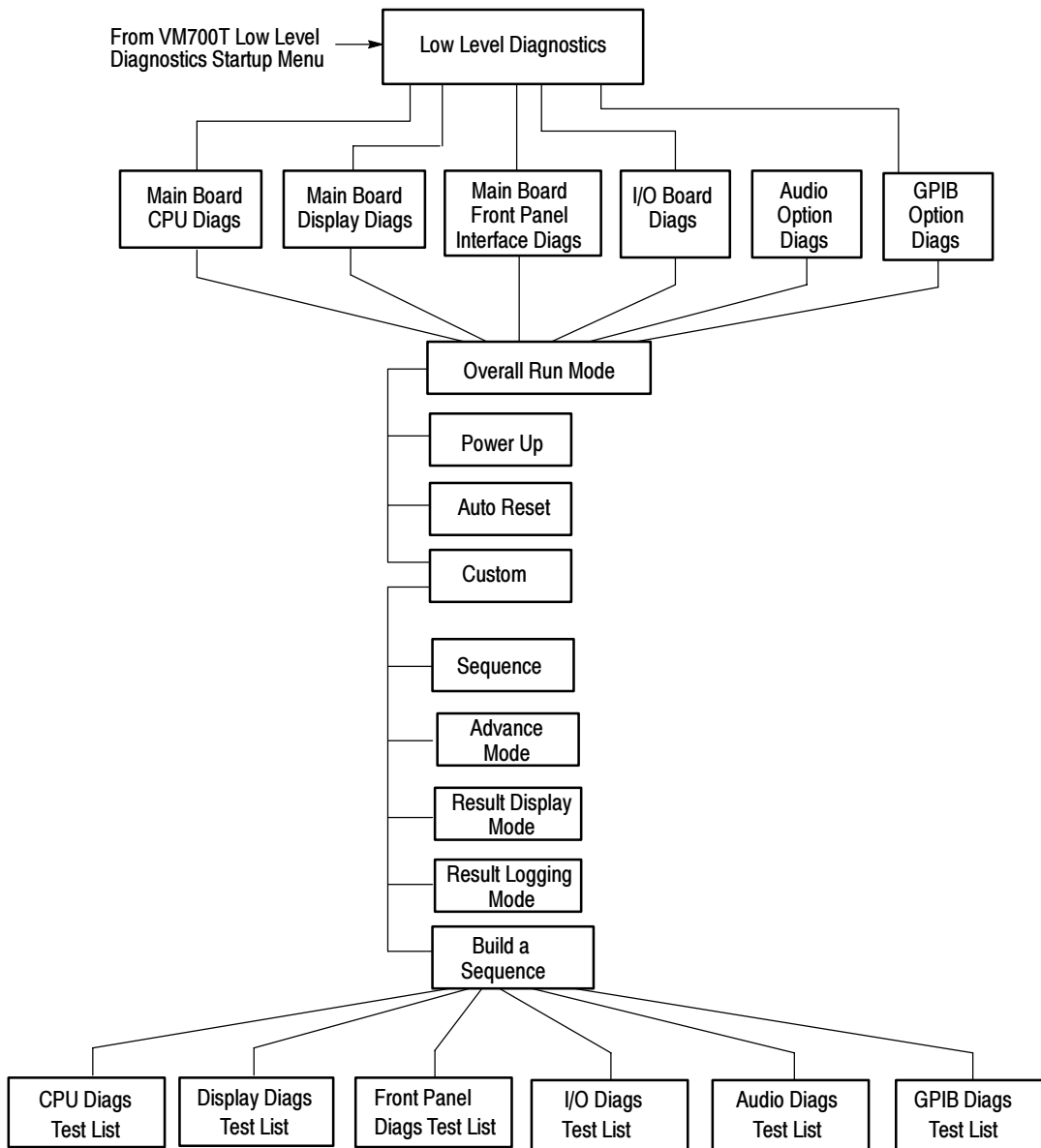

Use Abort or press the Auto button to back up the tree to the VM700T Startup Menu

Figure 6-32: VM700T diagnostic menus overview (cont.)

Low Level Diagnostics

Access to the diagnostics menu is available during power up by holding in the Menu front-panel button in when the power is turned on. Press and hold the Menu button while turning on the power. After the VM700T beeps twice to acknowledge the startup mode, release the Menu button. The VM700T then initializes directly into the Low Level diagnostics mode. The diagnostic operation begins with the Low Level Diagnostic Interface VM700T Startup Menu shown in Figure 6-33.

```

Low Level Diagnostic Interface
(knob moves cursor, "Select Line" inputs selection)
--- VM700T STARTUP MENU ---
Key          Selection
-----
R ... Instrument -RUN MODES- Menu
U ... -UTILITIES- Menu
D ... Low Level -DIAGNOSTICS- Menu
C ... Diagnostics -CONFIGURATION- Menu
H ... Diagnostics -HELP- Menu
T ... Calibrate -TOUCH PANEL INTERFACE-
= ... Reprint      @ ... Abort Menu
-----
Input your selection:

```

Figure 6-33: VM700T startup menu

In the VM700T Startup Menu highlight the “D” (Low Level Diagnostics Menu) and press the Select Line button again. This displays the Low Level Diagnostics menu shown in Figure 6-34.

```
Low Level Diagnostic Interface
(knob moves cursor, "Select Line" inputs selection)
--- LOW LEVEL DIAGNOSTICS---
Select a diagnostic to execute from the list below:

Key          Selection
-----
A ... Main Bd. CPU Diagnostics
B ... Main Bd. Display Diagnostics
C ... Main Bd. Fr-Pnl Infc Diagnostics
D ... I/O Board Diagnostics
E ... (Optional) GPIB Board Diagnostics
F ... (Optional) Audio Board Diagnostics
-----
= ... Reprint      @ ... Abort Menu
-----

Input your selection:
```

Figure 6-34: Low level diagnostics menu

The low-level diagnostics consists of sets of tests that check the CPU (central processing unit) including the display system and the front panel interface, and the I/O board circuitry. With the addition of the optional hardware for GPIB or Audio, low-level diagnostics are provided to test that hardware. These tests are bypassed at normal power-on unless they are configured to run by the user. Usually, this power up running of diagnostics will be the only use of diagnostics for the user. A service person can use the diagnostics to assist in determining if a board or board set is faulty before doing a board swap to effect repairs to the VM700T. The normal use of the diagnostic tests is for factory testing prior to shipment to the customer and repair testing of the boards returned in the board exchange program.

Selecting an Overall Run Mode. After you select one of the diagnostics to execute, you get a further choice of how you want to run it. The choices are shown in the Main Bd. CPU Diagnostic menu, Figure 6-35, as P, A, or C, (power up, auto reset, or custom mode respectively). The menu choices for each of the diagnostics: Main Bd. CPU, Main Bd. Display, Main Bd. Fr-Pnl Infc, and I/O Board, are all the same at this point. The diagnostic selected determines which is to be interactively run.

Power Up mode runs the power up diagnostics as at normal power up with an abbreviated go/no-go test of the circuitry.

Auto Reset Mode runs all the power up diagnostic tests available for the given diagnostic. These Auto Reset tests provide more extensive tests that exercise the circuitry for several seconds at each test.

The Custom choice permits you to select a single diagnostic test or build a selected set of diagnostic tests to run. This mode allows access to any or all of the available low-level diagnostic tests.

```

Low Level Diagnostic Interface
--- Main Bd. CPU Diagnostic ---

Select an OVERALL RUN MODE from the list below:

Key          Selection
-----
P ... -POWER-UP- Mode
A ... -AUTO-RESET- Mode
C ... -CUSTOM- Mode
-----
= ... Reprint    @ ... Abort Menu
-----

Input your selection:

```

Figure 6-35: Low level diagnostic OVERALL RUN MODE menu

Custom Run Mode Choices. The Custom Run Mode menu shown in Figure 6-35 permits configuration of the diagnostic testing sequence. You can select the Power Up mode, the Auto Reset mode, or a Custom run mode.

```

Low Level Diagnostic Interface

--- CPU Diagnostic ---

Configure CUSTOM RUN MODE parameters as desired, build/edit sequence,
then select "RUN" to begin execution

Key          Selection
-----
S ... -SEQUENCE- Type      (CUSTOM)

1 ... Advance Mode        (MANUAL)
2 ... Result Display Mode (SHOW ALL)
3 ... Result Logging Mode

B ... -BUILD- New Test Sequence

-----
= ... Reprint      @ ... Abort Menu
-----

Input your selection:
    
```

Figure 6-36: Custom run mode menu

From this menu, you can select how the diagnostic advances to the next test as Automatically, Advance on Pass, Advance on Fail, or Manually. You can select how the results are displayed from the choices of Show All, Show Main Results, or Show Minimum Required Results. How the results are logged is also selectable from a choice of Log the Main Results, Log all the Test Results, Log the Minimum Required Results, and Disable Results Logging. After you have built a custom test sequence, the added choices of running the test sequence and editing the test sequence are added to the list of menu choices.

To build a custom testing sequence, select B (Build) to display the entire list of diagnostics for the selected board. In Figure 6-37, Display Diagnostics was the selected set of tests. The other low-level diagnostics have a different list of test choices as appropriate for the board being tested.

Low Level Diagnostic Interface

--- Display Diagnostic ---

Build a new CUSTOM TEST SEQUENCE by selecting test from those listed.

Key	Selects/Unselects
A	... Video ASIC
B	... Video RAM
C	... Video Interrupt
D	... Int'l Brite DAC
E	... Ext'l Brite DAC
F	... Int'l RAM DAC
G	... Ext'l RAM DAC
=	... Reprint @ ... Abort Menu
+	... Select All - ... Un-SEL All
!	... Done Selecting
Selection(s): *** NONE ***	

Figure 6-37: Build CUSTOM TEST SEQUENCE menu for display

When the menu first appears, there are no selections made as indicated in the figure. To add a test to the list, rotate the large control knob to highlight the choice, then press the Select Line button. The selected choices are indicated by opening and closing angle brackets around the key letter and shown in the selections list. You can select all the choices in the list by highlighting the + and selecting it. All the choices can be unselected by highlighting the – and selecting it.

After you have made the test selections you want in the custom list, highlight the ! and press Select Line button. This also returns to the next higher level menu where the choice to run the tests in the custom list you have just made is available. When you run the tests, all the selected major test headings and the test results are shown along with the sub-test that run as part of the diagnostics. You can use the other added choice of editing the current test list if you want to make a change in the custom test list without rebuilding the entire list.

NOTE. *The custom list you build is not retained when exiting this menu.*

Diagnostic Help Menu. One of the menu choices in the VM700T START UP MENU is the diagnostic help menu. The help menu has two choices: *List special instrument power up modes* and *List diagnostic front panel button uses*. Figure 6-38 lists the front panel buttons that can be used directly to make menu selections. These keystrokes are in lieu of highlighting the menu choice and pressing the Select button when one of the listed key choices is available in a menu.

Low Level Diagnostic Interface

DIAGNOSTIC FRONT PANEL BUTTON USES
=====

Some Front Panel buttons may be used in place of moving the highlight cursor and pressing the <Select> button. Below are some common diagnostic menu selections and their Front Panel button equivalents.

Key	FR-PNL BUTTON
SPC (Pause)	Freeze
RET (Continue)	Display
'@' (Abort)	Auto
'=' (Reprint)	Menu
'+' (Select All)	A
'-' (Un-SEL All)	C
'!' (Done Selecting)...	Display
'>' (Next Menu Page)...	Arrows
'<' (Previous Menu Page)...	Move/Expand
-#- Press Any Key to Continue -#-	

Figure 6-38: Front Panel diagnostic selection buttons

Backdoor Boot Modes. The other choice in the diagnostic help menu provides a list of the special power up modes that are accessible through pressing and holding certain of the front panel buttons at power on. These are referred to as the “backdoor boot modes.” The choices are shown in Figure 6-39.

Bypassing the Power-Up Diagnostics. The factory Quick Start default bypasses the power-up diagnostics to shorten the power-up sequence, but it also prevents the VM700T from performing self tests at power-up. If the startup diagnostics have been reconfigured to run at power up, they can be bypassed from the front panel at power on. To bypass all power-up diagnostics (both low-level and high-level) when the VM700T is not configured for Quick Start, press and hold the Waveform button when you power on the VM700T. Release the button after the VM700T beeps twice (in about 10 seconds).

The VM700T displays the message:

Startup in Quick Start Mode Recognized.

Another message indicating all the diagnostics are being bypassed is then displayed and the VM700T proceeds with system initialization.

To bypass each user-selectable diagnostic as each begins to run or at any time during the running of the diagnostic, press the Abort Diagnostic soft key. The VM700T proceeds to the next selected diagnostic in the Diagnostics Selection file. After the last selected diagnostic either runs or is aborted, the VM700T proceeds with system initialization.

```

Low Level Diagnostic Interface

SPECIAL INSTRUMENT POWER-UP MODES
=====

These modes are accessed by powering up the instrument with
the indicated button(s) held in. The instrument will beep
twice and recognize the mode about 5 seconds after power-up,
after which the buttons must be released.

NOTE:The Boot Switches -MUST- be in their Factory Default
      position (ALL CLOSED) to access these modes.

POWER-UP MODES          BUTTON(S) TO HOLD IN
-----
QUICK START INSTRUMENT ... Waveform
RUN STARTUP MENU ..... Menu
REPROGRAM INSTRUMENT...Display & Waveform & Auto

-#- Press Any Key to Continue -#-
    
```

Figure 6-39: Special power-up boot modes

Diagnostic Utilities

The diagnostic utilities include selections for viewing or clearing the error log, clearing the file system NVRAM and CPU NVRAM, reprogramming the Flash ROM (with the appropriate software and uploading programs), showing the firmware date codes, finding the instrument ID number, and resetting the Option Key.

Reprogramming the Flash ROM will only be used for actually upgrading the firmware and requires the appropriate programming and upgrade software disks and a personal computer connection to the parallel printer port. Resetting the option key should only be needed if the VM700T does not boot up after a firmware upgrade. Its use requires knowing the authorized Option Key for the instrument.

Accessing the Diagnostic Utilities. To access the diagnostic utilities, perform the following steps:

1. Turn off the VM700T.
2. Press and hold the Menu button as you turn the power back on.
3. After the VM700T beeps twice, release the Menu button. The VM700T Startup Menu is then displayed (see Figure 6-40).
4. Use the front-panel knob to select U in the menu, and then press the Select Line button. This displays the Utilities Menu shown in Figure 6-41.

```

Low Level Diagnostic Interface
(knob moves cursor, "Select Line" inputs selection)
  --- VM700T STARTUP MENU ---
Key   Selection
-----
R ... Instrument -RUN MODES- Menu
U ... -UTILITIES- Menu
D ... Low Level -DIAGNOSTICS- Menu
C ... Diagnostics -CONFIGURATION- Menu
H ... Diagnostics -HELP- Menu
T ... Calibrate -TOUCH PANEL INTERFACE-
-----
= ... Reprint          @ ... Abort Menu
-----
Input your selection:

```

Figure 6- 40: VM700T Startup menu

```

Low Level Diagnostic Interface
(knob moves cursor, "Select Line" inputs selection)
  ---UTILITIES MENU---
Key   Selection
-----
E ... -ERROR LOG- utilities
N ... -NVRAM- utilities
R ... -REPROGRAM- Instrument
F ... Show -FIRMWARE- Date Codes
I ... Show -INSTRUMENT ID- number
O ... Reset Software -OPTION KEY-
-----
= ... Reprint          @ ... Abort Menu
-----
Input your selection:

```

Figure 6- 41: Diagnostic Utilities menu

Clearing the CPU NVRAM and FILE SYSTEM NVRAM. The diagnostic utilities include the NVRAM utilities. These utilities have a couple of uses: one is to recover after removing the CPU NVRAM or file system NVRAM plug-in modules from the CPU board; the other is to clear the file system of user files if the VM700T is being transferred to another user or work location.

The backup battery for the CPU NVRAM and file system NVRAM is on the CPU board. If the memory SIMM is removed from the CPU board, the stored memory is lost, and the memory cells will be in random states. Clearing the memory restores factory default settings for the file system and CPU so that the VM700T can be booted up.

Use the following procedure to clear the CPU NVRAM or the file system NVRAM:

1. Access the Utilities menu following the procedure on the preceding page.
2. From the Utilities menu (see Figure 6-41), use the front-panel knob to select N, and then press the Select Line button. This displays the NVRAM utilities menu with the following two choices:

F... Clear -FILE SYSTEM- NVRAM

C...Clear -CPU- NVRAM.

3. Use the front-panel knob to select F (to clear the file system NVRAM) or select C (to clear the CPU NVRAM), and then press the Select Line button. Each NVRAM selection has its own screen explaining what is done and what the resulting state of the file system will be after clearing. The Clear File System Utility screen is shown in Figure 6-42 and the Clear CPU NVRAM Utility screen is shown in Figure 6-43.

NOTE. *If you clear the CPU NVRAM, you must recalibrate the touch screen.*

4. Press the Menu button to clear the selected NVRAM or press any other button to abort the utility.

```

Low Level Diagnostic Interface
CLEAR FILE SYSTEM UTILITY
=====
### WARNING---Clearing File System NVRAM will destroy: ###
--All user files: setups, data, etc.
--The Diagnostic-Selection file and
the Diagnostic-Errors file.

[The instrument will revert to its Default NVRAM File System.]
[All diagnostics in the Diagnostics-Selection file will be ]
[enabled, and the Diagnostic-Errors file will be deleted. ]

### Press -MENU BUTTON- to clear NVRAM, any other button to abort. ###

```

Figure 6- 42: Clear File System Utility menu

```

Low Level Diagnostic Interface
CLEAR CPU NVRAM UTILITY
=====
### WARNING---Clearing CPU NVRAM will destroy: ###
--The TOUCH PANEL INTERFACE calibration
--Optional Hardware presence status
--Low Level Diagnostics configuration
--Low Level Diagnostics Error Log
--Low Level Diagnostics NVRAM Map

[The DIAGNOSTICS INTERFACE will revert to its factory default]
[settings and ERROR LOGGING will be disabled until instrument]
[power is cycled, or the instrument is otherwise reset. ]

### Press -MENU BUTTON- to clear NVRAM, any other button to abort. ###

```

Figure 6- 43: Clear CPU NVRAM Utility menu

Calibrating the Touch Screen

The VM700T is shipped from the factory with its touch screen fully calibrated. Although it will seldom be necessary, the touch screen can easily be recalibrated.

To calibrate the touch screen:

1. Switch off power to the VM700T at the front panel.
2. Press and hold the Menu button while turning on the power. After the VM700T beeps twice to acknowledge the startup mode, release the Menu button. The VM700T then initializes directly into the Low Level Diagnostics Interface with the VM700T startup menu as shown in Figure 6-40 on page 6-66.
3. In the startup menu, use the large control knob to highlight the T in the Calibrate Touch Panel Interface line.

4. Press the Select Line button to make the selection to calibrate. The first touch screen calibration instructions are then displayed as shown in Figure 6-44.
5. Follow the written directions. You can press AUTO to abort the calibration process and returns to the VM700T startup menu. Press any other button to store the setting in NVRAM and brings up the next touch screen calibration menu.
6. After you make the adjustment requested and store the current setting, a second set of instructions are displayed as shown in Figure 6-45. Follow the directions given in the screen.

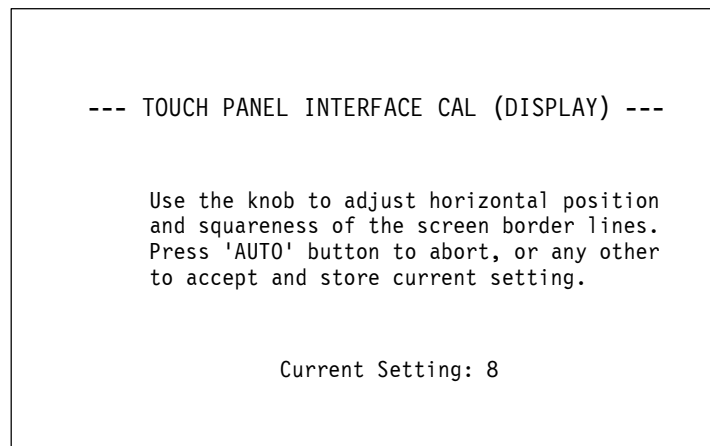

Figure 6-44: Touch screen calibration (display)

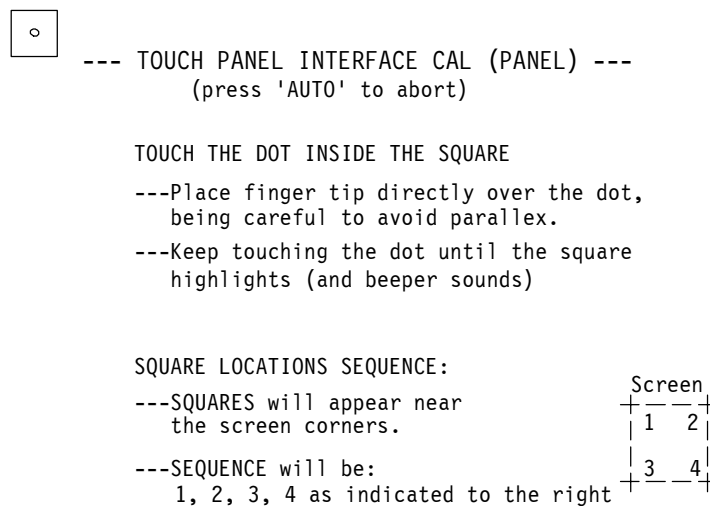

Figure 6-45: Touch screen calibration (panel)

7. After you have touched the dots at all four corners, a screen displaying some typical panel calibration factors is displayed as shown in Figure 6-46. From that screen, you can press any key to return to the VM700T startup menu.

```
--- PANEL CALIBRATION VALUES ---
```

```
XSCALE = 471      XOFFSET = 292
YSCALE = -398     YOFFSET = 231
```

```
-#- Press Any Key to Continue -#-
```

NOTE. Panel calibrations values vary greatly depending on the version of touch panel that is installed in your instrument. The sample values shown are typical of an older touch panel.

Figure 6-46: Panel calibration values

Setting the Power Up Mode

You can configure the instrument to always skip the power-up diagnostics or to always run them at power up. To access the diagnostics menus, press and hold in the Menu button while turning on the power to display the VM700T Startup menu shown previously in Figure 6-40 on page 6-66. In the VM700T Startup menu, highlight the C in the Diagnostic Configuration line and press the Select Line button. This brings up the Diagnostics Configuration menu shown in Figure 6-47. In this menu, highlight and select P in the Set Diagnostics Powerup Mode line to bring up the power up mode choices shown in Figure 6-48.

```

                Low Level Diagnostic Interface
(knob moves cursor, "Select Line" inputs selection)

    --- DIAGNOSTICS CONFIGURATION MENU ---
Key   Selection
-----
P ... Set Diagnostics -POWERUP MODE-
I ... Set Diagnostics -INTENSITIES-
B ... Set Low Level Diagnostics -BAUD RATE-
-----
= ... Reprint           @ ... Abort Menu
-----

Input your selection:

```

Figure 6-47: Diagnostic configuration menu

In the Set Diagnostics Powerup Mode menu shown in Figure 6-48, highlight and select Q to have the instrument skip diagnostics on power up or highlight and select P to have the instrument run the diagnostics on power up. The remaining choices are used in diagnostic testing in manufacturing and factory service. When a selection is made, the choice is stored in the diagnostics NVRAM, and the Diagnostics Configuration menu returns. At this point, the quickest way to start the instrument for normal operation is to turn off the VM700T and turn it back on again. You can also use the Abort Menu selection to back up the menu tree to the VM700T Startup Menu, and then select one of the run modes to restart the VM700T.

```

                                Low Level Diagnostic Interface
                                (knob moves cursor, "Select Line" inputs selection)

                                --- SET DIAGNOSTICS POWERUP MODE ---

                                Select a Powerup Mode from the list below. The mode selected will be
                                stored in Diag NVRAM and will be effective for -NORMAL- powerups
                                (ie: Boot Switches in NORMAL position). The current Powerup Mode
                                setting is -STARTUP MENU-.

Key           Selection
-----
Q ... QUICK START.....Skip Diagnostics, start Instrument
M ... STARTUP MENU..... Goto VM700T Startup Menu
P ... POWERUP DIAGS..... Do Diagnostics, start Instrument
L ... LOW LEVEL DIAGS LQOP.....Loop on Low Level Diagnostics
D ... HIGH LEVEL DEBUG..... Run Instrument in DEBUG MODE

= ... Reprint                               @ ... Abort Menu

Input your selection:

```

Figure 6-48: Set diagnostics power-up mode menu

Bypassing the Boot Switch Power-Up Mode. The boot switch can be set to start in various power up modes for Factory Service use in troubleshooting and testing. There is a diagnostic menu in the Low Level Diagnostic Interface (select P in Figure 6-48) that can be used to override the boot switch setting for starting up the instrument from that menu. That menu is the Instrument Run Modes Menu shown in Figure 6-49. Under normal operation, the boot switch settings will remain in the factory default positions for shipment, and the Instrument Runs Modes menu is not needed to override the boot switch.

Low Level Diagnostic Interface
(knob moves cursor, "Select Line" inputs selection)

--- INSTRUMENT RUN MODES MENU ---

The instrument will be reset to run in the mode selected below,
overriding current boot switch settings.

Key	Selection
N	NORMAL POWERUP.....Start Instrument in <Powerup Mode> Current <Powerup Mode> is QUICK START; abort this menu and go to the DIAGNOSTICS CONFIGURATION MENU to change it
P	POWERUP DIAGS.....Do Diagnostics, start Instrument
Q	QUICK START.....Skip Diagnostics, start Instrument
L	LOW LEVEL DIAGS LOOPLoop on Low Level Diagnostics
D	HIGH LEVEL DEBUG.....Start Instrument in <HL Debug Mode>
A	AUTORESET.....Do EXTRA Diagnostics, start Instrument
=	Reprint
@	Abort Menu

Input your selection:

Figure 6- 49: Instrument run modes menu

From this menu you can override the normal powerup settings and start up the VM700T in any of the indicated start up modes for one time. The Autoreset choice runs all the diagnostics prior to initializing, and it is a good choice when running the Verification procedure.

VM700T Boot Switch and Diagnostic LED

The Boot switch is located at rear, outer corner of the CPU board when viewed facing the right side of instrument and looking down at the CPU board.

In Figure 6-50, the Boot switch is shown in the Normal setting. That is with all switches set to the CLOSED position (pushed in at top). This is the normal setting for Quick Start operation of the VM700T and is the factory setting for shipment.

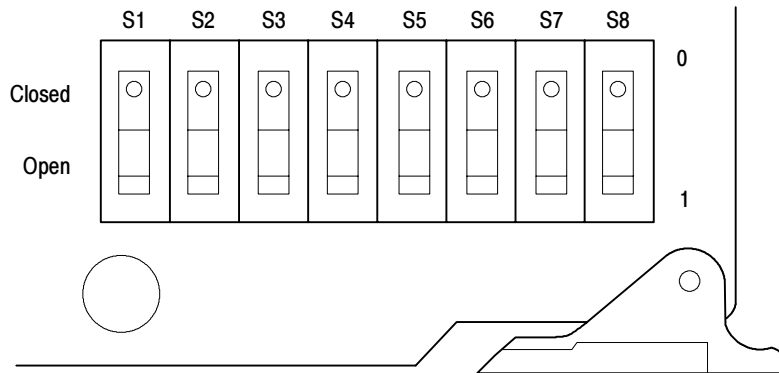

Figure 6-50: Normal Boot switch setting

Diagnostic LED. The diagnostic LED, located on the CPU board near the boot switch, is used to troubleshoot CPU kernel problems if the VM700T fails to boot. As the boot steps increment, the LED number also increments. If an error occurs, the LED will flash alternately between E and a number. That number indicates the failed area of the boot diagnostics. A P is displayed when the boot-up diagnostics all pass.

Running the High-Level Diagnostics

You can run individual, user-selectable diagnostics on demand either by pressing the Measure button during normal instrument operation or by powering the instrument up with the Measure button held in. The high level diagnostic test all run in the same manner.

To run a specific diagnostic during normal instrument operation, do the following steps:

1. Press the Measure button.
2. Press the Diags soft key.

The contents of the VM700T Diagnostics directory are displayed as shown in Figure 6-51. They include the user-selectable diagnostics available on power-up (listed in the Diagnostics Selection file), the DiagsLoop routine (described later in this section), and the routines AdcGain Adjustment, CalDAC adjustment, Measure Sinewave, and Measure Squarewave (described in the *Verification and Adjustment* sections of this manual).

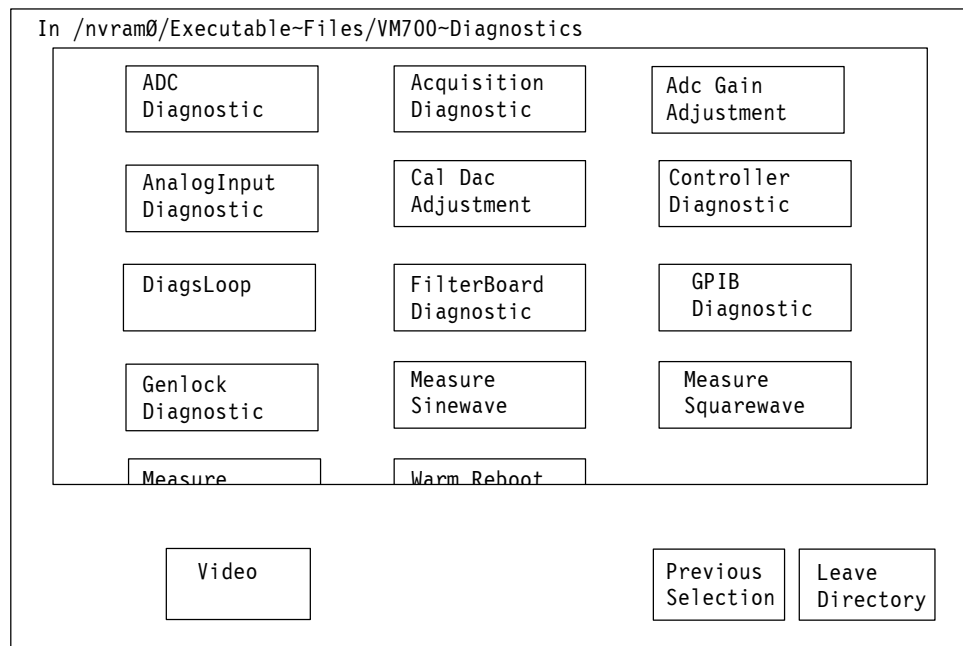

Figure 6-51: High level diagnostics menu

3. Select the soft key of a diagnostic you want to run.

An initial Diagnostic Menu is shown in Figure 6-52 (GPiB is the example). Except for the name, it is the same for all the high level diagnostic choices.

NOTE. *The GPIB diagnostic can be started through the GPIB interface itself (execute GPIB~Diagnostic), but this is not recommended. As soon as the GPIB diagnostic starts, the interface ceases to talk to the controller. To halt the GPIB diagnostic and return to remote control, press one of the front-panel hard keys. Upon exiting the diagnostic, the VM700T reboots and an SRQ is asserted. A serial poll after the reboot returns the power-on status byte (65). There are two run mode choices: Power-up and Interactive.*

Each diagnostic consists of a series of tests, and each series is organized into test families. When running individual diagnostics, you have two display choices: Power-Up Mode and Interactive Mode. These are described below.

To run a diagnostic, touch the icon representing that diagnostic in the directory window. When each diagnostic starts, you are prompted to select a run mode from the soft keys at the bottom of the screen as shown in Figure 6-52. The available choices are: Power-up Mode and Interactive Mode.

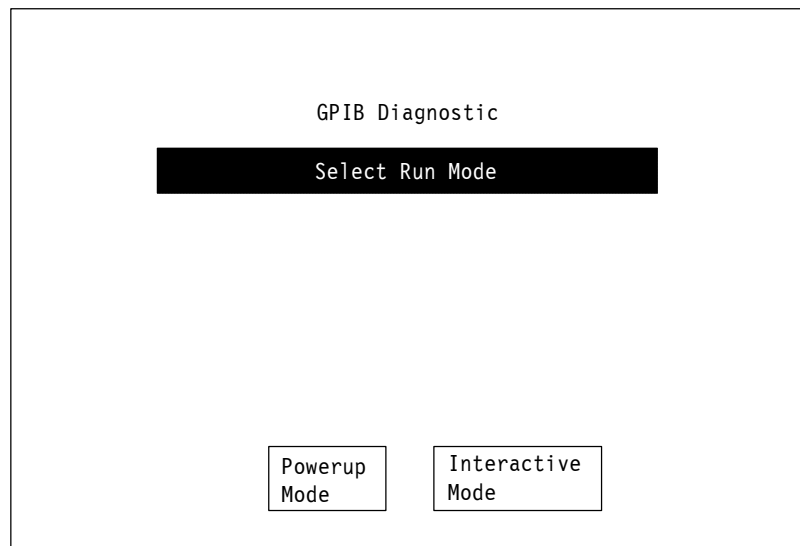

Figure 6-52: Select run mode, the high level diagnostic initial menu

Power-up Mode. Runs the selected diagnostic the same way it would run during power-up. Power-Up Mode, when selected, displays the Change Run Mode soft key. Touching the Change Run Mode soft key returns you to the SELECT RUN MODE screen. A diagnostics can be bypassed or configured to run in normal power-up mode. When configured to run, all the tests for that diagnostic are run completely through, and the display returns to the initial Diagnostic menu unless an error is found.

Power-Up Mode displays a line for each family of tests that passes. If any of the tests within the family fail, the program halts at the failed main test and shows the test block that failed. All the subtest titles are shown in the test block with any that failed marked with -FAIL-. Passed subtests are marked with -Pass-. There two additional soft keys labeled Continue and Rerun Test displayed on the screen. Continue resumes the diagnostic. Rerun Test repeats execution of the test family. Certain of the diagnostics will also display the message "Automatically Continues in 60 Seconds" after a failure and count down as the time elapses.

NOTE. *The powerup function key will not run at power on when GPIB is selected as the remote control port.*

When all the tests within a diagnostic routine have been completed, the Select Run Mode screen is displayed.

From the VM700T Diagnostics Startup menu, select R - INSTRUMENT RUN MODES. This brings up a second menu, the INSTRUMENT RUN MODES MENU (see Figure 6-49). In that menu, select A - AUTO RESET. That causes all the diagnostic test to run one time, before doing the system initialization.

Interactive Mode. Interactive Mode provides a greater level of detail for most tests within a diagnostic routine than Power-Up Mode. Interactive Mode, when selected, displays the Change Run Mode soft key. Touching the Change Run Mode soft key returns you to the SELECT RUN MODE screen.

In interactive mode, each main test block runs and the test halts at the end of each block. The main test title and all the subtest titles are shown with a -Pass- or -FAIL- label. You are given the choices of continuing the testing, looping on the selected test block, re-running the test block, or changing the run mode for the testing program as shown in Figure 6-53. Selecting to continue resumes the testing and runs the next main test. When all the tests within a diagnostic routine have been completed and the Continue soft key is selected, the Select Run Mode screen is displayed.

Test	meas't	units	min	max	result
VMIPC Register					-Pass-
Readable					-Pass-
Writable					-Pass-
Bit 0 Control					-Pass-
Bit 1 Control					-Pass-
Bit 2 Control					-Pass-
Bit 3 Control					-Pass-
Bit 4 Control					-Pass-
Bit 5 Control					-Pass-
Bit 6 Control					-Pass-
Bit 7 Control					-Pass-

Continue

Loop On
Test

Rerun
Test

Change
Run Mode

Figure 6-53: Interactive run mode menu after running first main test

DiagsLoop. You may, at times, want to run the user-selectable diagnostics continuously. Continuous (or looped) diagnostics are useful if you are looking for intermittent errors. The DiagsLoop application is located in the VM700T Diagnostics directory. DiagsLoop repeatedly runs the diagnostic routines selected in the Diagnostics Selection file.

DiagsLoop displays the same level of information as the Power-Up Mode of individual diagnostic execution, but DiagsLoop does not pause when failures occur. Results from all failed tests are written to the Diagnostic Errors file (refer to *High-Level Diagnostic Errors File* on page 6-84). To stop DiagsLoop execution, press the Abort Looping soft key.

Diagnostics Selection File. The Diagnostics Selection file allows you to specify the high-level diagnostics that run during Powerup Diagnostics or Diags Loop. When the VM700T is powered on with diagnostics enabled to run (not Quick Start), the diagnostics selected in the Diagnostics Selection file are run. The contents of the Diagnostics Selection file are shown in Figure 6-54.

Power Up Diagnostics Selection		
		Genlock-Diagnostic
		Controller-Diagnostic
		Acquisition-Diagnostic
		ADC-Diagnostic
		AnalogInput-Diagnostic
		FilterBoard-Diagnostic
		AudioProcessor-Diagnostic
		AudioAnalog-Diagnostic
		GPIB-Diagnostics
Selected	Line 6	Not Selected

Figure 6-54: Power-up diagnostics selection display¹

All diagnostic routines on the “Selected” side execute during Powerup Diagnostics or Diags Loop. To select or unselect a diagnostic from the Diagnostics Selection file do the following steps:

1. Press the Configure button.
2. Press the Configure Files soft key.
3. Select the Diagnostics Selection file.
4. Turn the control knob until the diagnostic’s name is highlighted. Touching the vertical center of the left half of the screen selects the highlighted diagnostic; touching the vertical center of the right half unselects it.
5. Press the Update & Exit soft key to write out (save) any changes to the file; press the No change & Exit soft key to leave the file as it was when it was last saved.

High Level Diagnostics Test. Figure 6-55 illustrates the diagnostic test blocks of the high level diagnostics to assist you in determining the module interdependencies for the successful completion of the tests. Table 6-4 lists and describes the VM700T high-level diagnostic tests. Additional diagnostics are added to this list with the addition of the hardware options (GPIB Interface, Audio Measurements, and Serial Digital Interface).

¹ **The AudioProcessor “Diagnostic and AudioAnalog” Diagnostic selections are available only with the VM700T Audio option. GPIB-Diagnostics is added to this list when the GPIB option is installed.**

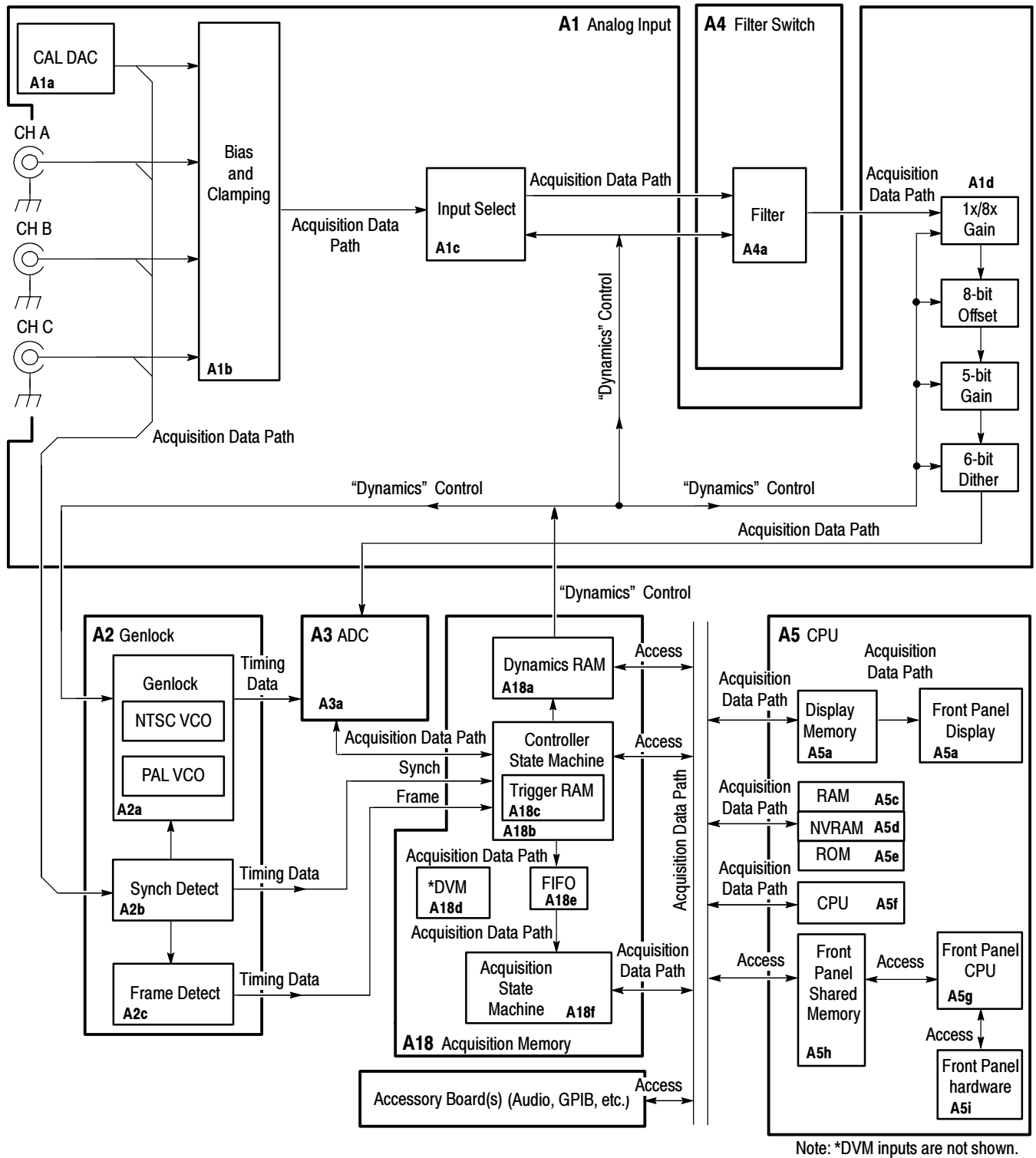

Figure 6-55: High level diagnostics test blocks

Table 6-4 lists and describes the VM700T high-level diagnostic tests. Additional diagnostics are added to this list with the addition of the hardware options (GPIB Interface and Audio Measurements).

Table 6-4: User-selectable diagnostics

Board tested	Test #	Test name	Description
Genlock (A2)	1	Status Checks	Verifies that the Genlock status register correctly represents the hardware configuration. <i>These tests must pass to run the lock tests.</i>
	2	NTSC (or PAL) VCO Lock	Checks the ability of the Genlock (A2) to acquire and hold lock using each VCO. The test forcefully breaks lock by toggling rapidly between internal and external sync with the genlock configured for the opposite standard. Then the genlock is configured for the standard being tested and time-to-lock is measured.
Controller portion of the Acquisition Memory (A18)	3	Control Registers	Checks mode, Genlock configuration, Genlock status, and filter control registers with 8-bit walking-1 and walking-0 patterns. Checks analog input register for writeability (no bus errors). Checks DVM readback register for readability.
	4	Overrange Detector	Checks bit 4 of the Controller interrupt register. ADC output is latched high to force the bit to set, and latched low to clear it.
Successful completion of these test require that the Genlock board (A2) be operating correctly.	5	Clock Detector	Checks bit 2 of the Controller interrupt register. Disables the sample clock to cause the bit to set, then re-enables the sample clock to clear the bit.
	6	Clamp Counters (A-C) and Acq Sig Counters (Sig0-Sig2)	Checks the counter chips. Performs walking-1 and walking-0 tests (read and write) and checks countdown over several reads.
	7	Register File	
	8	State Machine Settings, Trigger, and Sequence RAM	Checks SRUN and TRUN lines of the dynamics RAM; control, data, and address lines of the trigger RAM. Runs a checkerboard pattern test on the trigger RAM. Tests state machine sequence RAM.
Acquisition portion of the Acquisition Memory (A18)	9	RAM	Fills RAM with psuedo-random sequence, then reads and verifies it.
Successful completion of these tests requires that Genlock (A2) and Controller portion of the Acquisition Memory (A18) be operating correctly.	10	FIFO	Checks that data moves through the FIFO without overflow, even with processor bus contentions.
	11	Load /Looping	Checks that acquisition state machine can be programmed to write the contents of temporary store into acquisition memory locations, and that it can process acquisition program GOTO instructions.
	12	Optional Hardware	"Pass" indicates hardware present and working; "NA" indicates hardware not available.

Table 6-4: User-selectable diagnostics (cont.)

Board tested	Test #	Test name	Description
	13	External Triggers	Checks that Controller trigger RAM can be used to recognize when certain bits in the ADC data stream are set. Causes signal interrupts that are counted by the Controller's Sig0, Sig1, Sig2 counters.
	14	Long Acquisitions	Runs long acquisitions to verify interaction of Controller and Acquisition state machines.
	15	Sample Dropping	Uses Controller state machine to toggle offset level (a dynamic setting on the Analog Input board), while a long acquisition runs. Analyzes the acquired data to detect missing samples.
ADC (A3) Successful completion of these tests requires that Genlock (A2) and Acquisition Memory (A18) boards be operating correctly.	16	Mode Checks	Output latches in all zeros, all ones, normal, and overflow-bit modes and checks the ADC output by running an acquisition and scanning acquired data. The overflow bit test generates a drive level to overrange the board, then acquires data and checks to verify that the board's overrange bit was set.
Tests involving the Calibration DAC require that the Analog Input (A1) board be operating correctly.	17	Bit Patterns	Generates a calibration DAC drive level that produces an ADC level corresponding to the bit pattern shown in the individual test. The diagnostic runs a long acquisition and searches the acquired data for the individual test's bit pattern.
Analog Input (A1) Successful completion of these tests requires that the Genlock (A2) and Acquisition Memory (A18) boards be operating correctly.	18	DVM	Calibrates the DVM to the standard gating patterns for both TV standards (and the gating pattern that enables the DVM for all video lines) using a precise 1.000 volt reference and ground. ¹
	19	DC Paths	Checks that a nominal DC voltage can be routed through each input channel to the ADC.
	20	Gain Control	Checks gain control range and bit weights. ²
	21	Calibration DAC	Checks the range and bit weights of the calibration DAC.
	22	Offset Control	Checks the range and bit weights of the offset-control DAC.
	23	Input Selection	Checks the input selection switch by setting the channel bias DACs to different levels on each channel and measuring the net bias for each switch setting.
	24	Bias Control Range (for each channel)	Checks bias control DAC for range and bit weights. Verifies each DAC for independence by changing the other two and monitoring the one being tested to verify that its range and bit weight remain unchanged.

Table 6-4: User-selectable diagnostics (cont.)

Board tested	Test #	Test name	Description
	25	Clamp (for each channel)	Checks clamp level DAC for range and bit weights. Verifies each DAC for independence by changing the other two and monitoring the one being tested to verify that its range and bit weight remain unchanged. Measures fast- and slow-clamp response time by timing a 100 mV clamp-level change. Verifies fast clamping at each possible clamp-pulse width.
Filter	26	Times 8 Gain	Using the ADC, two Cal DAC DC levels are measured with x8 gain off, two more with it on, and the gain is calculated from the ratio of the differences.
Successful completion of these tests requires that the Genlock (A2), Acquisition Memory (A18), and Analog Input (A1) boards be operating correctly.	27	Filter Slot <i>n</i> (for slots 0 through 5)	Slot 0 is a bypass path, rather than a filter slot. These tests include filter ID and frequency response sub-tests. The filter ID sub-test checks instrument firmware to determine the TV standard and release version. This information is used by the diagnostic to determine valid filter ID for each slot. The frequency response sub-test generates a psuedo square-wave signal by switching channel input between A and B, with each channel input clamped to a different DC level. The signal is routed through the filter slot under test to the ADC, acquired, and analyzed. Discrepancies are displayed on screen. When an empty slot is correctly identified, this test displays NA.

- ¹ Each gating pattern has a different number of active video lines, so the ratio of the NTSC-pattern cal factor to always-on pattern equals the ratio of the NTSC pattern active lines to the always-on pattern number. The same is true for PAL.
- ² Range is the arithmetic sum of the measured bit weights, and bit weights are measured as the effect of toggling only the indicated bit.

Table 6-5 provides a cross reference between the test numbers and test names given in Table 6-4 with the hardware components tested. An X in the Test no. row indicates that the hardware component given in the column head is required to be operational for the test to pass. See Figure 6-55 for the hardware component reference. If one or more diagnostic tests fail, note the hardware components tested. They can be located on different modules, so the task is to determine which hardware component is causing the failure to occur. That will isolate the problem to a specific module that must be replaced to effect a repair. If there is a common hardware component or components tested in the different failures, suspect the module that has the common components.

NOTE. *The interdependencies between modules is very high. Several modules may have to be swapped into the instrument to determine the exact module that is causing a diagnostic failure. Table 6-5 is then used to determine the modules that are most probable to be the source of the failure.*

Table 6-5: Diagnostic test number to hardware components tested cross reference

Test no.	Test name	A1a	A1b	A1c	A1d	A2a	A2b	A2c	A3a	A4a	A18a	A18b	A18c	A18d	A18e	A18e
1	Status Checks					X										
2	NTSC (or PAL) VCO Lock					X										
3	Control Registers										1					
4	Overrange Detector								2		1					
5	Clock Detector					X			2		1					
6	Clamp Counters (A-C) and Acq Sig Counters (Sig0-Sig2)					X			2		1				X	X
7	Register File										1					
8	State Machine Settings, Trigger, and Sequence RAM										X	X	X			
9	RAM															X
10	FIFO											X	X		X	X
11	Load /Looping											X	X		X	X
12	Optional Hardware											X	X		X	X
13	External Triggers											X	X		X	X
14	Long Acquisitions				X	X			X			X	X		X	X
15	Sample Dropping				X	X			X			X	X		X	X
16	Mode Checks	X	X	X	X	X			X	X		X	X		X	X
17	Bit Patterns	X	X	X	X	X			X	X		X	X		X	X
18	DVM					X	X	X	X					X		
19	DC Paths	X	X	X	X	X			X	X		X	X		X	X
20	Gain Control				X	X			X			X	X	X	X	X
21	Calibration DAC	X	X	X	X	X			X	X		X	X		X	X
22	Offset Control				X	X			X			X	X		X	X
23	Input Selection			X	X	X			X	X		X	X		X	X
24	Bias Control Range (for each channel)		X	X	X	X			X	X		X	X		X	X
25	Clamp (for each channel)		X	X	X	X			X	X		X	X		X	X
26	Times 8 Gain				X	X			X			X	X		X	X
27	Filter Slot <i>n</i> (for slots 0 through 5)		X	X	X	X			X	X		X	X		X	X

¹ Test depends on miscellaneous control logic on the A18 board independent of the hardware components indicated in Figure 6-55.

² The timing data path depends on the presence of the ADC board, but does not rely on the ADC itself being operational.

Auto Reset (Running All Diagnostics)

If a malfunction causes the VM700T to reinitialize during normal operation, the VM700T tries to initialize in Auto Reset mode. This mode forces execution of all diagnostics, both low-level and high-level, regardless of the state of the Diagnostics Selection file.

If all diagnostic routines in the Diagnostics Selection file are set to Not Selected or if the Power Up diagnostics are set to Quick Start, no high-level diagnostics run at power up. If the VM700T does not complete system initialization because of a fault, the diagnostics are not available to assist in isolating the problem. In this case, you can force Auto Reset mode to ensure that all diagnostic routines run at power up. To force Auto Reset mode, perform the following steps:

1. Power off the VM700T. Press and hold the Menu button as you turn the power back on. After the VM700T beeps twice, release the Menu button to display the VM700T Startup Menu (see Figure 6-40 on page 6-66).
2. Use the front-panel knob to select R in the menu, and then press the Select Line button. This displays the Instrument Run Modes menu shown in Figure 6-56.
3. Use the front-panel knob to select A in the Instrument Run Modes menu. This restarts the VM700T and runs the full set of internal diagnostics.
4. Check that all tests pass as they run. If a test fails, refer to *High Level Diagnostics Test* on page 6-78.

Viewing Stored Diagnostic Information

If the VM700T diagnostics detect a problem, the Console and the Diagnostic Errors files may contain information useful for troubleshooting a problem. Both files can be printed using the Print File soft key.

Console File. Whenever the VM700T initializes, information is stored in the console file, located in the / directory (the topmost). If a malfunction causes the VM700T to auto reset, the console file could contain useful information. The console file is rewritten each time the VM700T is powered on. Compare the failure symptoms with the information in Table 6-3 on page 6-52 and run the self-test diagnostics to isolate a problem.

High-Level Diagnostic Errors File. When user-selectable diagnostics are run at power-up or during DiagsLoop (refer to *Diagsloop* on page 6-77), all errors detected are written to the Diagnostic Errors file, found in directory /nvram0/ConfigFiles. The Diagnostic Errors file is automatically created when an error is detected by user-selectable diagnostics.

NOTE. *The maximum capacity for the Diagnostic Errors file is 100 lines. If the number of errors detected produces a longer file, the earliest results are scrolled out, and a message stating that fact is included.*

```

                Low Level Diagnostic Interface
            (knob moves cursor, "Select Line" inputs selection)

            --- INSTRUMENT RUN MODES MENU ---

            The instrument will be reset to run in the mode selected below,
            overriding current boot switch settings.

            Key          Selection
            -----
            N ... NORMAL POWERUP.....Start Instrument in <Powerup Mode>
                Current <Powerup Mode> is QUICK START; abort this menu and go
                to the DIAGNOSTICS CONFIGURATION MENU to change it

            P ... POWERUP DIAGS.....Do Diagnostics, start Instrument
            Q ... QUICK START.....Skip Diagnostics, start Instrument
            L ... LOW LEVEL DIAGS LOOP .....Loop on Low Level Diagnostics
            D ... HIGH LEVEL DEBUG.....Start Instrument in <HL Debug Mode>
            A ... AUTORESET.....Do EXTRA Diagnostics, start Instrument
            -----
            = ... Reprint                                @ ... Abort Menu
            -----
            Input your selection:
    
```

Figure 6-56: Instrument Run Modes menu

Viewing Diagnostics Remotely

You will not be able to view diagnostic results if the VM700T display either is not operating or is operating improperly. The VM700T supplies a method, known as Debug mode, to view diagnostic results on a terminal or PC should the display be malfunctioning. You can isolate a display problem to the display monitor by viewing the output signal from the VGA connector. If that display is normal, but there is no display on the CRT, check the display monitor.

In Debug mode, the VM700T redirects the low-level diagnostics display data to the rear panel PORT 0 serial connector. To view the diagnostics you must connect a terminal or PC to PORT 0. If you connect a PC, you must also run a terminal emulator program on the PC to read the output from the VM700T.

In Figure 6-57, the Boot switch is shown in the setting that enables output to the serial I/O port 0. That is with all switches set to the CLOSED position (pushed in at top) except S6. The password feature is also enabled by this switch setting, but if the password file is empty, a password is not needed to make file changes.

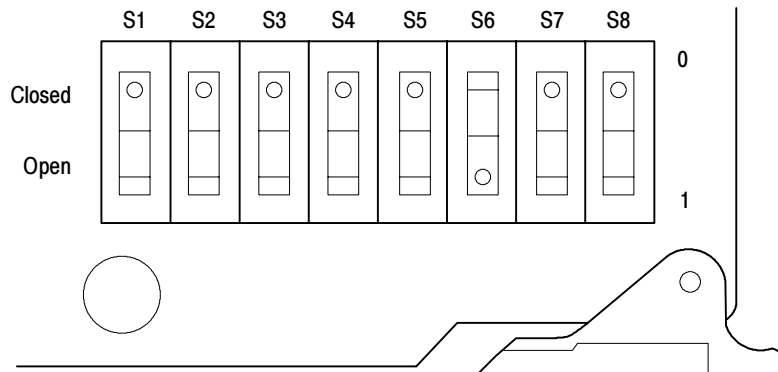

Figure 6-57: Boot switch setting to enable diagnostic output to serial port 0

Setting the Console Baud Rate. The baud rate setting for output of the diagnostics through the serial port must be set to match the requirements of the terminal or terminal emulation program used to monitor the output. Setting the diagnostic baud rate is done in one of the choices in the Diagnostics Configuration Menu shown in Figure 6-58. Select B . . . Set Low Level Diagnostics -Baud Rate- and press the Select Line button to enter the menu. The recommended baud rate setting for most applications is 9600 baud. If the display is not working, this is the baud rate to try first for viewing the diagnostics information. The VM700T is capable of 38800 baud. If the display is working, you can set the baud rate as high as your terminal or terminal emulation program will handle. Be sure to set the baud rate of the terminal to match.

```

                Low Level Diagnostic Interface
(knob moves cursor, "Select Line" inputs selection)

    --- DIAGNOSTICS CONFIGURATION MENU ---
Key   Selection
-----
P ... Set Diagnostics -POWERUP MODE-
I ... Set Diagnostics -INTENSITIES-
B ... Set Low Level Diagnostics -BAUD RATE-
-----
= ... Reprint           @ ... Abort Menu
-----

Input your selection:
    
```

Figure 6-58: Diagnostics Configuration menu

Connecting a Terminal or PC. The VM700T has two DB9 RS-232C DTE serial ports on its rear panel (see Figure 6-59). These serial ports can be used to send graphics and reports to a printer, for remote operation via a modem, or for viewing diagnostics by direct serial connection to an RS-232C device such as a terminal. Both serial port 9-pin male D connectors are located on the A20 CPU I/O board and are accessible from the rear panel of the instrument, as shown in Figure 6-59.

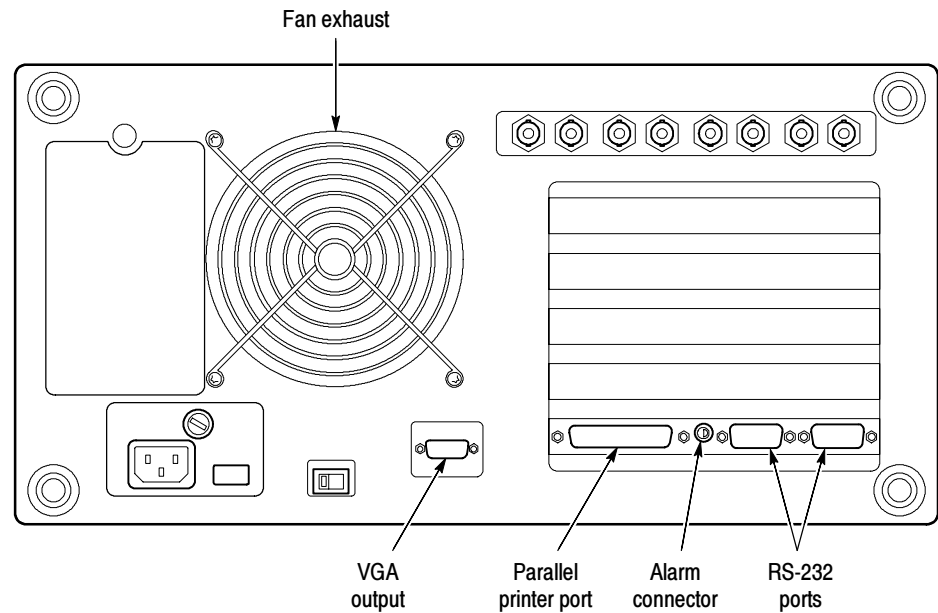

Figure 6-59: VM700T rear panel

The Communications Setup file (located in the Configure Files directory) contains the parameter settings for the serial ports. Typical Communications Setup choices for VM700T-to-PC communications are shown in Table 6-6.

Table 6-6: Typical communication setup parameters

Parameter	Selection	Parameter	Selection
Protocol	None	Parity	None
Baud Rate	to match PC	Reset Character	Disabled
Flow Control	XON/XOFF	Carrier Detect	Disabled
Character Size	8		

VM700T RS-232 Connector Pin Outs. The two RS-232C DTE ports of the VM700T are used to output graphics and reports to a printer, as well as for remote operation via a modem or direct serial connection. Both connectors are located on the CPU I/O board and are accessible on the rear panel. Both are 9-pin male “D” connectors. The Communications Setup file is found in the Configure Files directory (press Configure and then touch the Configure Files soft key), and contains parameter settings for both ports. Configuring the Communication Setup file is covered in the *VM700T Option 01 & Option 11 User Manual*.

Table 6-7 describes the signals the VM700T outputs and the input signals required on all the active pins of the serial ports.

Table 6-7: VM700T RS-232 connector pin outs

Pin number	Function	Description
1	DCD (Data Carrier Detect)	This signal typically comes from a modem and indicates that a phone connection is made.
2	RD (Receive Data)	The VM700T receives data on this pin.
3	TD (Transmit Data)	The VM700T transmits data on this pin.
4	DTR (Data Terminal Ready)	This pin is always high when the VM700T is turned on. Modems typically require this signal to be a high level or they won't answer the phone.
5	SG (Signal Ground)	
6	DSR	Unused in the VM700T and not internally connected.
7	RTS (Request To Send data to the VM700T)	With hardware flow control (CTS/RTS selected), normally RTS connects to the CTS line of a terminal, and the line is active when the VM700T is ready to receive data. When the receive buffers of the VM700T are nearing capacity, RTS goes inactive, indicating to the sending device to stop transmitting data. With software flow control (XON/XOFF selected) or None selected, RTS is always active.
8	CTS (Clear To Send)	With Flow Control (CTS/RTS selected), the VM700T is enabled to transmit data by a high level on pin 8, and is disabled by a low level. It is normally connected to the RTS line of a terminal. With Flow Control (None or XON/XOFF selected), the VM700T transmits data regardless of the CTS level.
9	RI	Unused.

NOTE. *Not all RS-232C devices use control lines as described in this section. Refer to the instruction manual of the equipment you are connecting to the VM700T to determine exactly how it should be connected.*

Table 6-8 gives the null modem cable configurations for 9-pin to 9-pin and 9-pin to 25-pin DTE connectors that should work in most cases for remote control and for viewing the output of the VM700T in debug mode. The pin numbers listed for the Terminal (DTE) are the most common locations for the corresponding signals.¹

Table 6-8: Typical RS-232C null modem cable wiring

VM700T (DTE) to terminal with 9-pin (DTE) connector		VM700T (DTE) to terminal with 25-pin (DTE) connector	
VM700T pin no.	Terminal pin no.	VM700T pin no.	Terminal pin no.
1 (DCD)	4 (DTR)	1 (DTR)	20 (DTR)
2 (RD)	3 (TD)	2 (RD)	2 (TD)
3 (TD)	2 (RD)	3 (TD)	3 (RD)
4 (DTR)	1 (DCD)	4 (DTR)	6 (DSR) & 8 (DCD)
5 (Signal Ground)	5 (Signal Ground)	5 (Signal Ground)	7 (Signal Ground)
6 (Unused)	6 (DSR)	6 (Unused)	20 (DTR)
7 (RTS)	8 (CTS)	7 (RTS)	5 (CTS)
8 (CTS)	7 (RTS)	8 (CTS)	4 (RTS)
9 (Unused - RI)	9 (Unused - RI)	9 (Unused - RI)	1 (Unused - FG)

¹ Both ends of a DTE-to-DTE cable are usually female DB-25 connectors.

Troubleshooting the Power Supply and CRT Display

This section contains information on how to troubleshoot the power supply module and the CRT display.



WARNING. High voltages present inside the VM700T chassis can cause serious injury. All service procedures that require removing instrument covers should be done only by a qualified service person.

Power Supply

The VM700T power supply is a high efficiency switching supply. Field repairs to a VM700T with a power supply problem are done by board exchange. Refer to *Exchanging VM700T Modules* on page 6-3 for more information.

Front Panel Check. Check the LED indicators over the front panel STBY/ON switch (see Figure 6-60). One red LED is an over temperature warning and the other is a power supply failure indicator. If the green Power indicator is on, primary power is applied, the line fuse is good, and the housekeeping voltage supply is operating. If no indicators come on, either the primary power circuitry has failed or the master ON/OFF switch is OFF. Check the line fuse and the master ON/OFF switch to make sure it is on. Also make sure the Line Voltage Selector switch is set to the correct supply voltage. If the Line Voltage Selector was not set to the correct setting, the fuse may have opened. If the line fuse is good, the master switch is ON, the Line Voltage Selector set correctly, and the power supply still does not operate, troubleshoot the power supply.

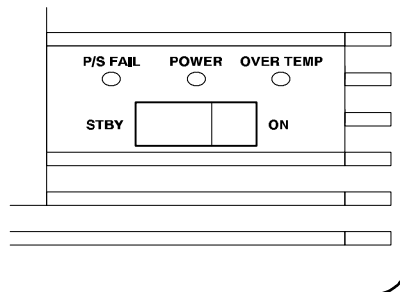

Figure 6- 60: Front-panel power supply and over temperature indicators

If the Over Temp indicator is on and the instrument is still operating, then an over temperature condition exists. If the temperature continues to rise a power supply shutdown may occur. The over temperature warning occurs at about 50° C, and the power supply will shut down at about 60° C. The ambient temperature may be too high to operate the VM700T or the flow of cooling air is cut off or restricted. The VM700T should be shut off to let it cool down before a shutdown occurs.

Internal Checks. If the PS Fail indicator is on, then there is a power supply problem. Turn off the master ON/OFF switch on the rear panel of the VM700T and remove the holding screws from the right side (as viewed from the front) cover. Slide the cover back about 8 inches to gain visual access to the power supply LED indicators. Locate the power supply LED indicators near the front at the bottom of the chassis (see Figure 6-61). Turn the master ON/OFF switch back ON.

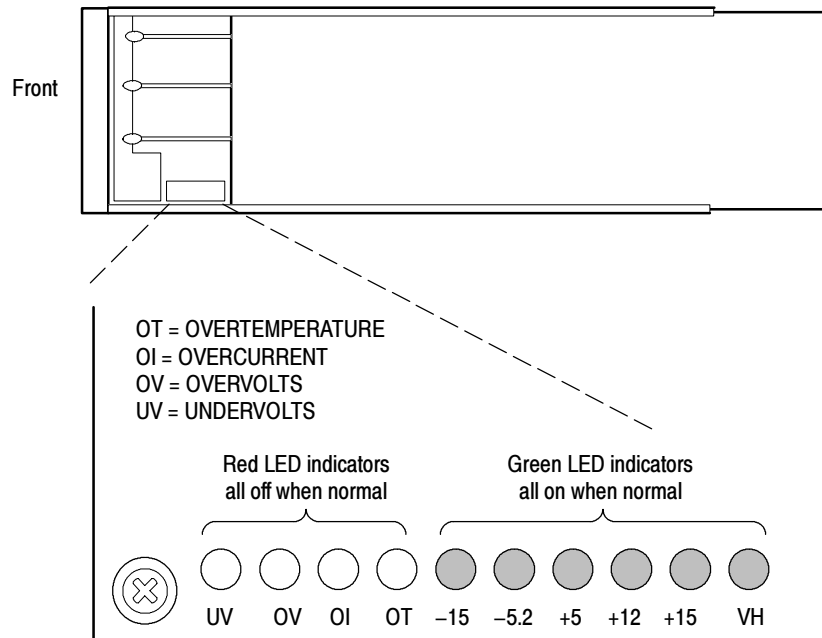

Figure 6-61: Power supply LED indicators

Check that the VH (housekeeping supply) LED indicator comes on (see Figure 6-61). If it does not come on, replace the power supply. Refer to *Power Supply Module* on page 6-38 for power supply removal instructions.

Check the green LED indicators on the power supply. Each voltage supply is provided with an indicator to show that the associated voltage is up. All the green indicators should be on for normal operation of the power supply.

Check that none of the RED indicators are lit. If any are on, a power supply problem is indicated.

If the VH (housekeeping voltage) LED is on and the other green voltage indicators are flashing on and off, check the status of the OI (over current) LED.

If the OI LED is flashing or on solid, there may be excessive loading on the power supply by the VM700T circuitry. See Table 6-9 for checks and actions for the various trouble indications.

Table 6-9: Power supply trouble indicators

Indicator	Checks	Action
Undervoltage LED on	Check Supply LED indicators to check for a missing supply voltage.	Replace power supply using board exchange. For information on how to return defective instrument modules to Tektronix for repair, see <i>Exchanging VM700T Modules</i> .
Over Voltage LED on	Check that all the green Supply LED indicators are off except the VH LED. The supply will be in shutdown mode.	Turn the master ON/OFF switch off and back on to recycle the power supply shutdown control circuitry. Check that the power supply operates normally after power is reapplied and the front-panel STBY/ON switch is turned on. If not, replace the power supply.
Over Temperature LED on	<p>Check Supply LED indicators to see if an over temperature shutdown has occurred. The green LED indicators for the supply will be on if a shutdown has not yet occurred. Check that the fan is operating.</p> <p>Over temperature shutdown of the supply will occur at about 10°C over the warning temperature. At that point, all the green power supply indicators except the VH LED will be off.</p>	<p>Turn off the master ON/OFF switch and let the VM700T cool down before restarting the power. When the power comes back on check that the fan operates and that the power supply operates correctly.</p> <p>Check the air filters in the instrument's front bezel. If they become clogged, the lack of air flow may cause overheating. Use a mini-vacuum cleaner to remove the dust from the filters. For more information on cleaning the front bezel air filters, see <i>Cleaning the Touch Screen and Front Bezel Air Filters</i>.</p>
Over Current LED on	Check for flashing supply LED indicators.	<p>Check for possible excessive loading on a power supply by the VM700T. Troubleshoot the VM700T for excessive loading problems. Circuit boards may be unplugged, one at a time, to check for board related loading. If the over current fault goes away after you remove a circuit board or disconnect a cable assembly from the instrument, that circuit board may be the faulty module. Replace with a known good module to check. Return a faulty module for replacement or repair.</p> <p>Minimum load to maintain operation of the power supply is 30 W total including at least a 10 W (2A) load on the +5.1 V supply.</p>

Power Supply Voltage and Ripple Check. To check the power supply for voltage and ripple tolerances, the bottom cover of the VM700T must be removed. Turn off the VM700T and remove the bottom cover. Use Figure 6-62 to locate the power supply voltage test points (this information is also on the bottom cover of the power supply). Refer to Table 6-10 for the tolerance and ripple values.

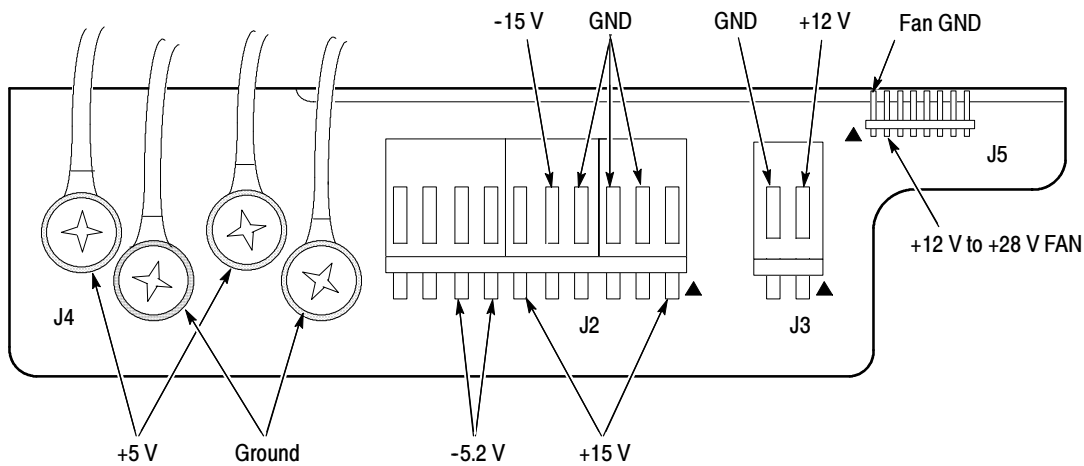

Figure 6-62: Power supply test points

Table 6-10: Power supply voltages

Voltage	Tolerance @ standard load	P.A.R.D. max (mV) ¹ (ripple)	Circuitry supplied
+5 Vdc	±1% @ 18A	150	TTL Logic
+15 Vdc	±2% @ 1 A	120	Analog
-15 Vdc	±2% @ 1.2 A	120	Analog
+12 Vdc	±2% @ 1 A	150	Display
12 to 30 Vdc			Fan Drive
-5.2 Vdc	±3% @ 5 A	150	ECL Logic
VH	14.4 V @ 50 mA ²		Control Circuitry

¹ Total Periodic and Random Deviations (Pard) measured at the power supply output connector includes peak-to-peak noise, ripple, switching spikes, etc., within a bandwidth from 5 Hz to 20 MHz.

² The housekeeping voltage (VH) is 11.4 V before the rest of the power supply comes on line.

Troubleshooting the CRT Display

The display module is a 9-inch diagonal, 640 x 480 pixel, monochrome CRT unit. The display is adjusted at the factory for optimum viewing brightness. The interactive touch screen is attached in front of the CRT. It can be removed for replacement of the touch screen or the display module, if necessary.

If the CRT display fails, the faulty unit must be removed and replaced. For information on replacing the CRT display module, refer to *Removing and Replacing Display and Control Components* on page 6-32.

When a CRT display module is replaced, minor adjustments may be necessary to center the display or fine-adjust its brightness level. Refer to *Adjusting the Display* on page 5-10 if readjustment is needed. Part of the Touch Screen calibration procedure also makes some adjustments to the display. If you replace the touch screen, perform the touch screen calibration procedure on page 6-68.

Isolating a CRT Display Fault. Two types of CRT display failures can occur:

- No display (blank screen)
- No display and POWER SUPPLY FAIL LED lit

For no display (blank screen) CRT display symptoms, follow this procedure:

1. Connect an external VGA monitor to the rear panel VGA connector. If there is no display on the external monitor, the problem may be in the CPU or display driver circuitry on the CPU board. Exchange the CPU board with a known good one to see if the display returns. If there is a VGA output display, but none on the CRT, continue with these checks.
2. Make sure that +12 V is present on pin 7 of the CRT display connector (on the back of the display module). If +12 V is not present, remove the 10-pin drive connector to see if the +12 V comes up. If it does, the CRT display may be loading the power supply. Change to CRT display assembly and check again to see if the display returns.
3. With an oscilloscope, probe pins 6 (horizontal sync), 8 (video), and 9 (vertical sync) of the CRT display connector for valid drive signals.
4. Adjust the brightness and contrast controls on the bottom of the CRT display unit to see if they affect the display.

For blank screen and lighted POWER SUPPLY FAIL LED symptoms, follow this procedure:

1. Switch the instrument power off at the rear-panel switch.
2. Disconnect the CRT 12 V power connector (P3) at the power supply and switch instrument power on to see if the display monitor was loading the power supply. If the POWER SUPPLY FAIL LED is no longer lit with the 12 V cable disconnected, replace the CRT display module.

Troubleshooting Option 40 and Option 41 (Audio)

The purpose of the troubleshooting techniques described here is to isolate an audio option fault to one or both of the audio boards. You can use the audio diagnostics (refer to *Audio Option Diagnostics* on page 6-97) to help isolate the fault. After isolation, the faulty board(s) may be exchanged to make a repair. Board-level audio option faults can be isolated by following the steps shown in Figure 6-63.

The Audio Processor board has no test points or adjustments. Troubleshooting this board consists of running its diagnostics. If the board passes the diagnostics, it is operating correctly; but if it fails, it must be replaced.

Diagnostics are also used to verify the Audio Analog board performance. However, isolating a diagnostic failure to a fault on this board also requires performing the additional checks shown in Figure 6-63.

Figure 6-64 shows the Audio Analog board locations for the checks listed in Figure 6-63.

Refer to *Option 40 and Option 41 Audio Boards Removal and Replacement* on page 6-11 for information on removing and replacing the audio option boards in the VM700T.

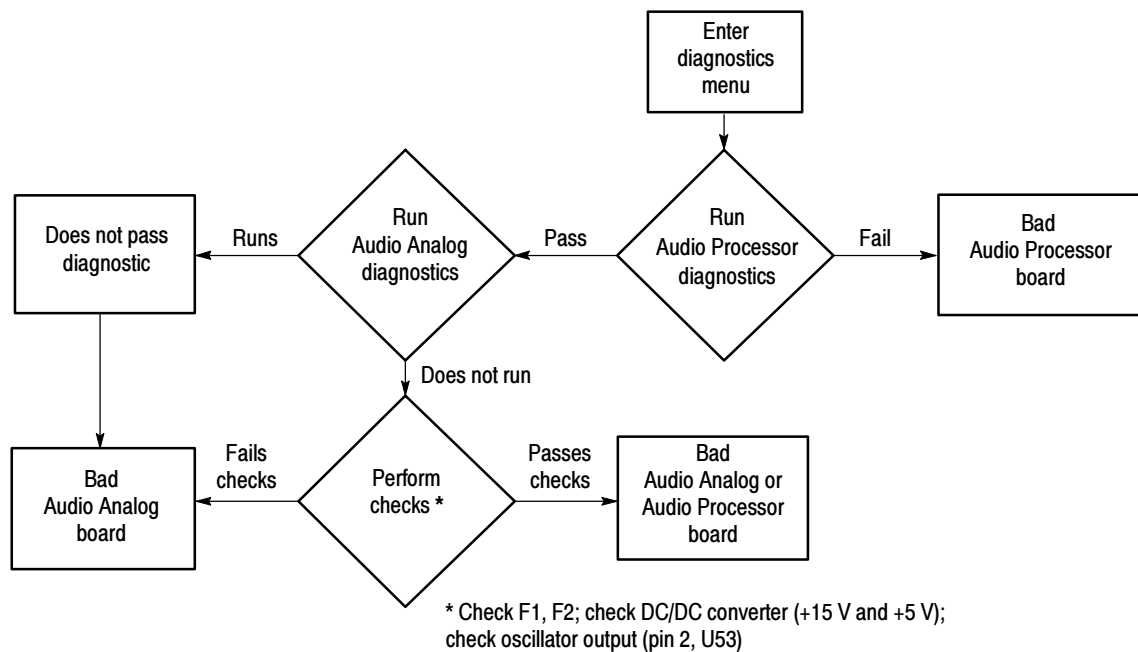

Figure 6-63: Procedure for troubleshooting the audio option boards

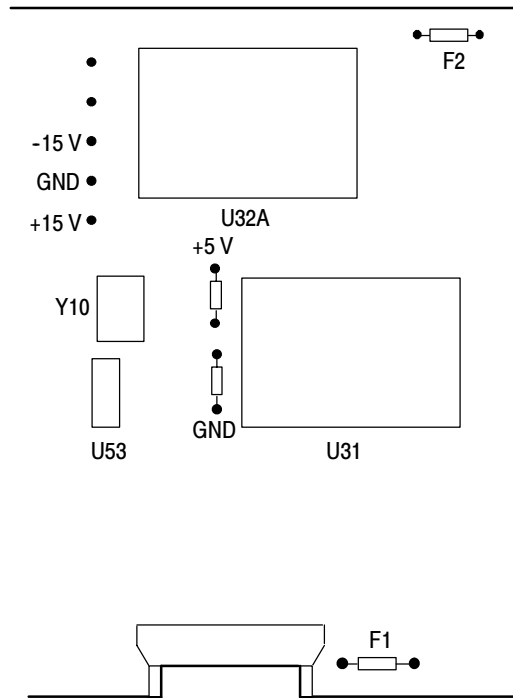

Figure 6-64: Test positions on the Audio Analog board

Audio Option Diagnostics

The Audio Processor board has no test points or adjustments. Troubleshooting this board consists of running its diagnostics. If the board passes the diagnostics, it is operating correctly; if it fails, it must be replaced. The video measurements of the VM700T are still usable if the VM700T passes the rest of the diagnostics. Table 6-11 describes the Audio Processor board diagnostics, and Table 6-12 describes the Audio Analog board diagnostics. Like the other VM700T user-selectable diagnostics, these can be configured to run at power up, on demand, or in a continuous loop when either Option 40 or Option 41 is installed in the VM700T Video Measurement Set.

Table 6-11: Audio Processor board diagnostics

Test name	Description
DSP program RAM	Standard RAM tests that check decoded address space size, RAM segment size, and integrity of address and data bus to each block of parts. Tests perform a simple checker-board pattern test of RAM from the 68020 with the 56001 disabled. Data is read as 32-bit, with the upper 8 bits masked in software.
DSP X data RAM	Same as above
DSP Y data RAM	Same as above
Sign extend buf	Checks that the 32-bit data correctly represents 24-bit sign-extended data where the upper 8 bits are the same as the sign bit.
Shared bus timing	The 68020 writes a long sequence of data into DSP X memory and reads it. During this write and read, the DSP runs code that accesses its Y and P memories. The test passes if the sequence gets in and out of the memories with no errors. Timing is checked for 3 cases: (1) Audio interrupts to DSP disabled, audio data register not accessed; (2) Audio interrupts to DSP enabled, audio data register not accessed; (3) Audio interrupts to DSP enabled, audio data register accessed.
DSP host port	Verifies the major modes of the DSP host interface. These modes are used in audio application software. This test checks the 68020's ability to initialize the DSP host port, tests the host port handshake flag bits, and tests data transfer from the 68020 to the DSP through the host port.
Audio data reg	If the audio hardware revision number is less than 8, this test is labeled N_A and skipped. Otherwise, the loopback mode is used to route output data from the DAC into the audio data register. This test writes long walking-1 and walking-0 sequences to verify each audio data register bit.
Interrupt reg	Checks interrupt register bits. Tests the run bit to see if it stops and starts code on the DSP. Reads the revision bits and checks for range. Readable and writeable bits are tested with walking-1 and walking-0 sequences, but bits that are read-only are tested for resistance to writing. Ignored bits are checked to always read 0.
Sample dropping	If the audio hardware revision number is less than 8, this test is labeled N_A and skipped. Otherwise, the loopback mode is used to route output data from the DAC into the audio data register. The DAC generates long sequences of known values toggling at known intervals. These are sampled by the audio data register into DSP shared memory and analyzed by the CPU microprocessor.

NOTE. *The Audio Analog board tests require an operating Audio Processor board (A12), because they involve synchronized exchanges between a DSP program running on the audio processor microprocessor and an application running on the CPU microprocessor.*

Table 6-12: Audio Analog board diagnostics

Test name	Description
DAC calibration (offset and gain)	Self-calibrates the ADC and calibrates the output of the DAC against the chopper. Gain is the ratio of DAC-to-chopper output. Offset is the difference between the signal midpoint of the DAC and that of the chopper.
ADC calibration (offset and gain)	Checks for completion of the ADC internal self-calibration and calibrates the ADC against the chopper. Gain is the ratio of acquired signal amplitude to chopper reference amplitude. Offset is the difference between acquired signal midpoint and ADC midrange value.
ADC bit patterns	Tests for walking-1 and walking-0 bit patterns in DAC sample data.
Cal-signal paths	DAC and chopper signals are routed via all possible paths to the ADC (with gain and attenuation set to 0) to verify continuity and separation of the two input channels.
Attenuator steps	Signals from the DAC are routed through the available attenuator steps, acquired by the ADC, and analyzed. Attenuation is the ratio of atten-off to atten-on voltage.
Gain steps	Signals from the DAC are routed through the available gain stages, acquired by the ADC, and analyzed. Gain is the ratio of gain-on to gain-off voltage.
Notch filters	DAC signals are routed through the notch filters and gain is measured as the ratio of notch-on to notch-off voltage.
Left flatness	Tests left-channel flatness with sine waves generated by the DAC (gain and attenuation are 0 dB and the notch filter is off).
Right flatness	Tests right-channel flatness with sine waves generated by the DAC (gain and attenuation are 0 dB and the notch filter is off).

Troubleshooting Option 48 (GPIB)

Troubleshooting the GPIB board consists of running the GPIB diagnostics. The GPIB Diagnostic routine does extensive testing of the interface hardware. Failure of any diagnostic test indicates a hardware problem that requires servicing. The VM700T may function for local operation, but may be faulty for remote operation if a GPIB Diagnostic test fails. Refer to *Diagnostic Selection File* on page 6-78 to configure the Diagnostic Test Selection file to either run or skip the GPIB diagnostic when running the high-level diagnostics. The main test titles are as follows:

- VM IPC Register
- VM Program RAM
- VM Shared RAM
- VM Private RAM
- VM Cen Ctl Reg
- VM Gpib Chip
- GP Program RAM
- GP Shared RAM
- GP Private RAM
- GP Spurious Ints
- GP Int From VM
- GP Clk Tick Int
- GP Get Int

Each of these main tests have a number of subtests. Refer to Appendix B of the *VM700T GPIB Interface Programmer Manual* for the complete test list if you need to further troubleshoot the GPIB board.

Troubleshooting Option 1S (SDI)

The purpose of the troubleshooting techniques described here is to isolate an SDI option fault to one or both of the SDI boards. After isolation, the faulty board(s) may be exchanged to make a repair.

Before You Troubleshoot. If you suspect that Option 1S is not operating properly, perform the following steps before you perform the troubleshooting procedures.

1. Verify that the VM700T is set to Mode: Digital.

NOTE. *The VM700T must be set to Mode: Digital before you can access any Option 1S functions. You cannot access any Option 1S functions if the VM700T is set to Mode: Analog.*

2. Verify that all Option 1S and VM700T diagnostics pass (refer to *SDI Option Diagnostics* on page 6-104).
3. Inspect the rear-panel connectors for damage.
4. Inspect the internal cable connections between the SDI Rear Panel Interface assembly and the SDI board, and the cable between the SDI board and the Acquisition/Controller board.

The instructions for isolating the SDI option faults listed below are found on the following pages:

- No signal from the SDI Ch. A input
- No signal from the SDI Ch. B input
- No signal from the Analog Ref input
- No signal from the AES/EBU Digital Audio input
- No signal from the LTC Time Code input
- No signal from the SDI Output connector

No Signal From the SDI Ch. A Input

Perform the following steps when the VM700T will not display a known signal on the SDI Ch. A input:

1. Connect a digital video signal to the SDI Ch. A input and terminate the loopthrough connector.
2. Set the VM700T to display the channel A signal using the SDI Waveform application.

NOTE. *The VM700T must be set to Mode: Digital. The Source Selection Digital configuration file must be set Auto Detect or for the bit rate and standard of the digital test signal.*

3. Check for a Loss of Signal message on the display.
4. If hardware trouble is indicated other than the Loss of Signal message, replace the SDI board.

NOTE. *Various user settings can dramatically alter the displayed waveform in ways that may appear to indicate a malfunctioning circuit. In the SDI Waveform application, these user settings include Menu selections of Style, Display, Display Diff, Free Run, as well as the front panel controls of Move and Expand. Verify these settings before assuming a malfunction exists.*

5. Swap the SDI Ch. A and SDI Ch. B cable connections on the SDI board at J7 and J8 (see Figure 6-65).
6. Connect the signal input to the SDI Ch. B input connector (leave the VM700T front panel set to display the channel A signal).
7. Check that there is a signal display.
8. If there is still no signal display on channel A, replace the SDI board.
9. If there is a signal display on channel A.
10. Check J5 pin 9 for 13 to 15 VDC (see Figure 6-65).
11. Check J5 pin 10 for -13 to -15 VDC.
12. If one or both voltages are bad, replace the SDI board.
13. If both voltages are good, remove the SDI Rear Panel Interface assembly.
14. Check that the cables are properly seated in their connectors on the SDI Rear Panel Interface assembly.
15. Disconnect the flat cable and the green channel A cable from the SDI Rear Panel Interface assembly.
16. Check each of the wires in the flat cable and the green cable for continuity.
17. If the cables are good, replace the SDI Rear Panel Interface assembly.

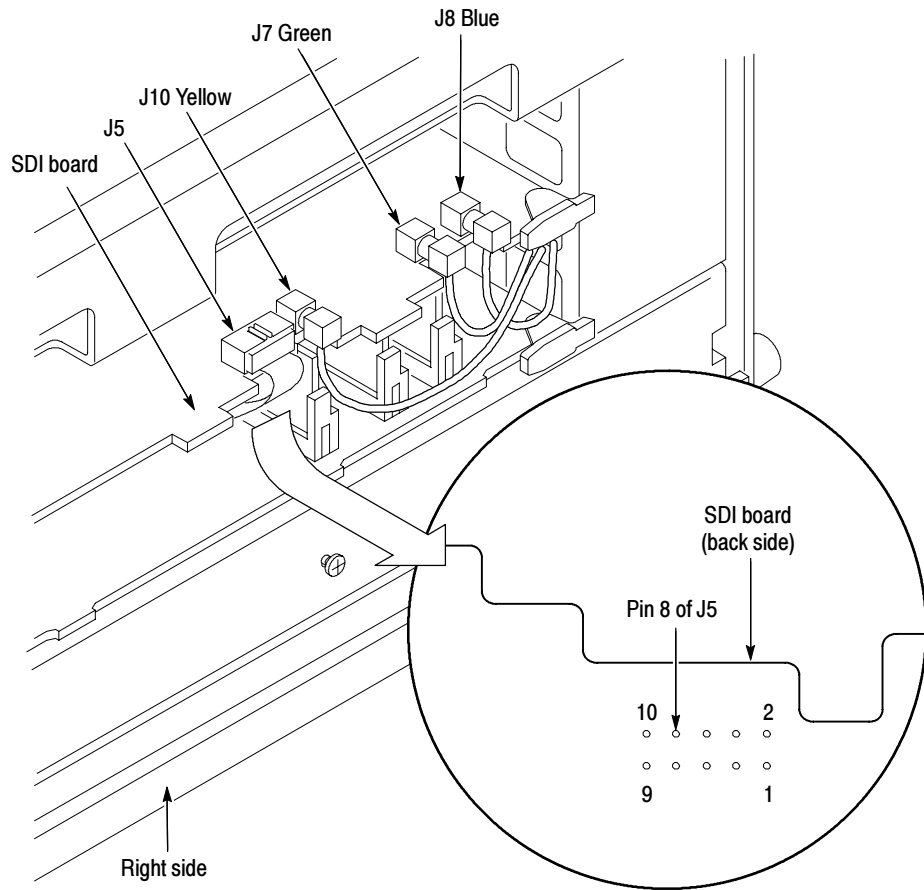

Figure 6-65: SDI board cable connections and J5 pinouts

No Signal From the SDI Ch. B Input

Perform the following steps when the VM700T will not display a known signal on the SDI Ch. B input, but the SDI Ch. A input operates:

1. Connect a digital video signal to the SDI Ch. B input and set the VM700T to display the channel B signal.
2. Swap the SDI Ch. A and SDI Ch. B cable connections on the SDI board at J7 and J8 (see Figure 6-65).
3. Connect the signal input to the SDI Ch. A input connector (leave the VM700T front panel set to display the channel B signal).
4. Check that there is a signal display.
5. If there is still no signal display on channel B, replace the SDI board.
6. If there is a signal on channel B, replace the SDI Ch. B cable.

No Signal From the Analog Ref Input

Perform the following steps when the Analog Ref input does not operate, but the SDI Ch. A input operates:

1. Connect an NTSC television signal to the Analog Ref input.
2. Check for a video signal on J5 pin 8 on the SDI board. Leave the J5 cable installed and probe the board from the bottom as shown in Figure 6-65.
3. If the video signal is present on J5 pin 8, replace the SDI board.
4. If the video signal is not present, remove the SDI Rear Panel Interface assembly.
5. Disconnect the flat cable from the SDI Rear Panel Interface assembly, and then check each of the 10 wires in the cable for continuity.
6. If the cable is good, replace the SDI Rear Panel Interface assembly.

No Signal From the AES/EBU Digital Audio Input

Perform the following steps when the AES/EBU Digital Audio input does not operate:

1. Connect an AES/EBU digital audio signal to Option 1S.
2. Check for an audio signal on J5 pin 2 of the SDI board (see Figure 6-65).
3. If the audio signal is present on J5 pin 2, replace the SDI board.
4. If the audio signal is not present, remove the SDI Rear Panel Interface assembly.
5. Disconnect the flat cable from the SDI Rear Panel Interface assembly, and then check each of the 10 wires in the cable for continuity.
6. If the cable is good, replace the SDI Rear Panel Interface assembly.

No Signal From the LTC Time Code Input

Perform the following steps when the LTC Time Code input does not operate:

1. Connect a time code signal to Option 1S.
2. Check for a time code signal on J5 pins 4 and 5 of the SDI board (see Figure 6-65).
3. If the time code signal is present on J5 pins 4 and 5, replace the SDI board.
4. If the time code signal is not present, remove the SDI Rear Panel Interface assembly.
5. Disconnect the flat cable from the SDI Rear Panel Interface assembly, and then check each of the 10 wires in the cable for continuity.
6. If the cable is good, replace the SDI Rear Panel Interface assembly.

No Signal From the SDI Output Connector

Perform the following steps when the SDI Output connector provides no signal, but the SDI Ch. A and SDI Ch. B inputs operate:

1. Connect a digital video signal to the SDI Ch. A input and terminate the loopthrough connector.
2. Connect a cable from the SDI Output connector to the SDI Ch. B input.
3. Check that you can display the SDI Ch. B signal on the VM700T.

NOTE. Set the Source Selection Digital configuration file to output the selected channel to the SDI Output connector.

4. If there is no signal display, disconnect the cable from J10 on the SDI board (see Figure 6-65).
5. Check the center pin of the J10 connector for a digital video signal.
6. If the video signal is not present, replace the SDI board.
7. If the video signal is present, replace the SDI Output cable.

SDI Option Diagnostics

Option 1S is composed of three modules and two sets of interconnects (see Figure 6-66). The SDI and the Acquisition/Controller diagnostics effectively identify failures to the Acquisition/Controller board, the SDI to Acquisition/Controller interconnect, and the SDI specific hardware when signal sources are connected as shown in Figure 6-67. Most SDI specific hardware errors occur on the SDI board.

NOTE. The analog measurements of the VM700T are still usable if the Option 1S diagnostics fail but the VM700T passes the rest of the diagnostics.

Running the Option 1S Diagnostics

Like the other VM700T user-selectable diagnostics, the Option 1S diagnostics can be configured to run at power up, on demand, or in a continuous loop when Option 1S is installed in the VM700T.

The following procedure provides instructions on how to connect signals to Option 1S in order to perform the full set of option diagnostics. The diagnostics do not verify any specifications; but they do provide a high level of confidence that the option is working properly. Table 6-13 lists the Option 1S diagnostic tests. To verify instrument operation to published specifications, refer to the *SDI Option 1S Performance Verification* on page 4-25.

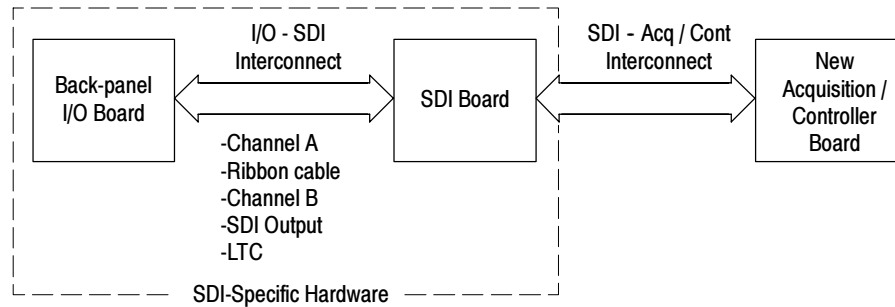

Figure 6-66: Option 1S simplified block diagram

1. Connect signals to all of the Option 1S rear-panel connectors as shown in Figure 6-67.

NOTE. The internal power-up diagnostics for Option 1S provide the greatest degree of testing for instrument functionality when all rear-panel connectors have proper signals connected to them. When these signals are not present, the diagnostic tests that require input signals will report “N/A” (not applicable).

2. Press the front-panel **Measure** button, and then touch the **Diag** soft key.

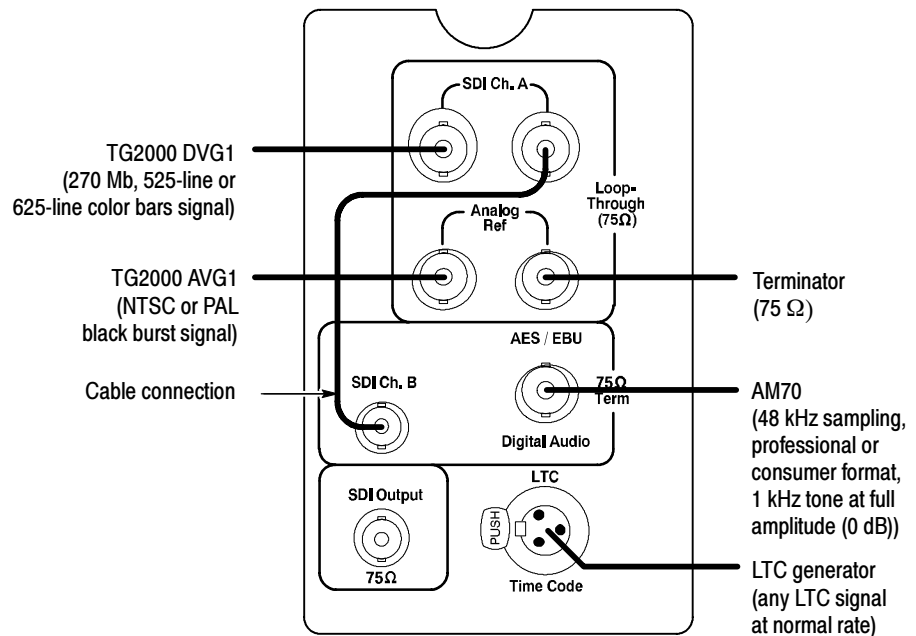

Figure 6-67: Signal connections for performing Option 1S diagnostic tests

3. Rotate the front-panel knob until you locate the SDI Diagnostic soft key.
4. Touch the **SDI Diagnostic** soft key to access the SDI diagnostic routine.
5. Touch the appropriate soft key to select the diagnostics run-mode type (Power-Up or Interactive).

NOTE. *Diagnostics performed from the Measure menu offer two modes: Power-Up and Interactive. In Power-Up mode, the diagnostics display a one-line header for each test being run. Should the diagnostics encounter an error, the measurement set waits for user acknowledgement.*

In Interactive Mode, the diagnostics display more detail about each test being performed. Before starting the next test in the list, the measurement set waits for user acknowledgement.

6. Observe the displayed diagnostic test results as they are performed. Diagnostic tests that do not pass display a highlighted Fail message.
7. The Rerun Test soft key lets you rerun diagnostic tests.

Option 1S Diagnostics Table 6-13 describes each the SDI diagnostic tests.

Table 6-13: SDI Option 1S diagnostic test descriptions

Test name	Description
<p>SDI board version</p> <p>SDI board ID bits</p> <p>Acquisition memory size</p> <p>System size Xcheck</p>	<p>This is a miscellaneous group of tests which verify and/or display the particulars of the SDI board and the environment it needs to work properly. These tests are as follows:</p> <p>There is an 8-bit board ID field encoded on the board. The least significant 4 bits of this field are implemented by means of resistors R912, R913, R914 and R915, and can be influenced by installing or not installing these resistors. The next 4 bits are encoded with the PAL (U730). The first diagnostic in this group simply reads these 8 bits on the least significant 8 bits of the processor's data bus and displays the results. Presently, there is no formal method of rolling this ID field, but installing and removing these resistors may provide a tool for manufacturing troubleshooting. Hence, the pass/fail field will always show PASS.</p> <p>The product configuration requires that any VM700T containing the SDI option also be equipped with a 1Mb acquisition memory on the Acquisition/Controller board. This test probes the Acquisition/Controller board and displays the amount of acquisition memory found on the board. Thus, the pass/fail field will always show PASS. This check is intended to allow factory personnel to verify that the VM700T is properly configured for the SDI option. The true detected size of the acquisition memory is reported. If it is 1 Mb, this test will PASS, or else it will FAIL.</p> <p>The acquisition memory size detected in the above test is compared against the size detected at system boot. If the two are different, this test will FAIL. This test was put in because at one point in the development of the SDI board, mismatches of this kind were seen.</p>
<p>SDI serial EEPROM</p> <p>EEPROM initialized</p> <p>EEPROM checksum</p>	<p>The serial EEPROM (U158) is used to store calibration constants. It is written by the SDI Calibration application (primarily), although SDI_EyeDiagram also writes some additional calibration constants to it. There are two tests in this group.</p> <p>A standard library in the software is used to read and write this device. The first time the device is written, the library code writes the constant 5A hex to the first of 256 locations in the EEPROM. The first test checks for this, and fails if some other number is found in the first location. Thus, a failure of this test indicates that the board was never calibrated since the EEPROM was installed or replaced.</p> <p>The second test reads the entire data block and computes a CRC on all but the last 32 bits (which contains the reference CRC). The computed CRC is compared against the reference CRC and the test fails if there is a mismatch.</p>

Table 6- 13: SDI Option 1S diagnostic test descriptions (Cont.)

Test name	Description
SDI Ctrl. Regs.	<p>There are 5 control registers (0-4) and one status register on the SDI board. All are 32 bits in size, and all are readable and writable. The correlation between these registers and devices on the board is as follows:</p> <p>Control Register 0: LS 16 bits - U49, MS 16 bits - U50 Control Register 1: LS 16 bits - U47, MS 16 bits - U48 Control Register 2: LS 16 bits - U51, MS 16 bits - U52 Control Register 3: LS 16 bits - U56, MS 16 bits - U53 Control Register 4: LS 16 bits - U54, MS 16 bits - U55 Status Register: LS 16 bits - U57, MS 16 bits - U58</p>
Ctrl. Register 0-4	<p>Each control register is subjected to a write/read test using the test patterns 0x55555554, 0xAAAAAAAA, 0xFFFFFFFF, 0x00000000, 0x33333332, 0xCCCCCCCC, 0x77777776, and 0x88888888. If the data written does not match the data read, the test fails, and a message indicating expected and actual results is printed to the console.</p>
Ch A/B Rate Bits	<p>Each of the 2 SDI channels on the board can be forced into a manual lock mode by setting the autorate bit for the channel (bit 1 for channel A and bit 6 for channel B in control register 0) to 0. When this is done, bits <3..2> and <8..7> are used to select the manual rate desired (143, 177, 270, or 360 MHz.). These values are then reflected back in the status register in bits <4..3> and <9..8> respectively. This fact is used to do a loop-back test between control register 0 and the status register. If the bits match, the test passes.</p>
Ch A Manual Rate	<p>Channel A is commanded to lock to each of 4 frequencies on the input (143, 177, 270, and 360 MHz.) and the frequency to which the channel locks is displayed. If the front end logic detects the absence of a signal, then this test is flagged as N/A.</p>
Ch A Auto Rate	<p>If there is no signal, this is flagged N/A. Otherwise, the SDI board is placed in autorate mode, and after a waiting period, the status register is checked to see which frequency the circuit locks to. This frequency is displayed.</p>
Ch A Rate Xcheck	<p>If there is no signal, this is flagged N/A. Otherwise, the manually determined frequency is compared with the frequency detected in autorate mode. If there is a difference, the test fails.</p>
Ch B Manual Rate Ch B Auto Rate Ch B Rate Xcheck	<p>Repeat of the checks run for channel A.</p>
A/D Converter	<p>This group checks the calibration DAC, the voltmeter and associated circuits on the board. The tests are as follows:</p>
Voltmeter Inputs	<p>The voltmeter (U28) has 16 possible inputs feeding it through U26 after selection through the analog muxes U25 and U121. Each of these inputs is selected in turn, converted and displayed. For the 4 inputs that are connected to known values (i.e. U25.4 and U121.6 to 2.5000 VDC and U25.11 and U121.9 to ground), the values are read and compared against high and low limits. In these 4 cases, the tests will fail if the values are out of limit. The other 12 inputs are simply read and displayed, with the tests always flagged as PASS.</p>
Cal. DAC Wraparound	<p>One of the outputs of the calibration DAC (U135.21) is connected to one of the inputs of the voltmeter (via U121.10). This fact is exploited to perform a wraparound test using three different voltages (0.0, 1.25 and 2.5 VDC).</p>

Table 6- 13: SDI Option 1S diagnostic test descriptions (Cont.)

Test name	Description																
PLL Centering	This test verifies the tuning range of the VCO phase lock loop at 143 Mb, 270 Mb, and 360 Mb.																
LTC Chip	<p>The LTC chip (U60) receives longitudinal time code from an external source. The chip is a ICS 2008A. Its functions are entirely hard wired, and the diagnostic has little to do except reset the device (by toggling pin 2 high then low), waiting 33 ms for the device to lock to any external signal that may be present, and then reading the status from the chip. If the status says that there is no signal (bit 2 of register SMPTE1 is 0), then the test is flagged as N/A because this condition means that the chip thinks there is no valid signal connected.</p> <p>If there is a signal, the diagnostic merely reads the time code and prints it to the console after flagging the test as PASS (since we have no means of comparing the timecode against a known reference to decide if it is correct, we merely show it to the user, and let them judge the correctness).</p>																
<p>Audio Receiver</p> <p style="padding-left: 40px;">Data Validity Flag</p> <p style="padding-left: 40px;">Valid Data Mvmt</p> <p style="padding-left: 40px;">Spurious Data Mvmt</p>	<p>The audio receiver chip is a crystal CS8412, and its functions are all hard wired on the board, and thus not amenable to manipulation by the diagnostic program. The diagnostic proceeds as follows:</p> <p>There is a 3-bit field in the device which is used to report the status of the data. This value is read and displayed, and can have the following meanings (for details, please refer to the CS8412 data sheet):</p> <table border="0" style="margin-left: 20px;"> <tr> <td>OK</td> <td>(0) Data is valid</td> </tr> <tr> <td>VALFLG</td> <td>(1) Validity Bit High (in data stream)</td> </tr> <tr> <td>CONFLG</td> <td>(2) Confidence Flag</td> </tr> <tr> <td>SLIPPD</td> <td>(3) Slipped Sample</td> </tr> <tr> <td>CRCERR</td> <td>(4) CRC Error</td> </tr> <tr> <td>PARERR</td> <td>(5) Parity Error</td> </tr> <tr> <td>CODERR</td> <td>(6) Bi-Phase Coding Error</td> </tr> <tr> <td>NOLOCK</td> <td>(7) No Lock</td> </tr> </table> <p>If the data validity flag is NOLOCK, then it means there is no signal, and the second test is bypassed (i.e. flagged N/A). Otherwise, data acquisition is performed, and the diagnostic checks all 10 bits to verify that they are all toggling. If they are not, then the diagnostic generates a message to the console for each bit that is not toggling.</p> <p>The third test is run only if there is no valid data, since in that case, the chip is supposed to output a data stream of all zeroes. Hence, the third test checks for bits that are not zero, since this indicates a spurious data movement condition. Each such bit is announced via a message on the console.</p>	OK	(0) Data is valid	VALFLG	(1) Validity Bit High (in data stream)	CONFLG	(2) Confidence Flag	SLIPPD	(3) Slipped Sample	CRCERR	(4) CRC Error	PARERR	(5) Parity Error	CODERR	(6) Bi-Phase Coding Error	NOLOCK	(7) No Lock
OK	(0) Data is valid																
VALFLG	(1) Validity Bit High (in data stream)																
CONFLG	(2) Confidence Flag																
SLIPPD	(3) Slipped Sample																
CRCERR	(4) CRC Error																
PARERR	(5) Parity Error																
CODERR	(6) Bi-Phase Coding Error																
NOLOCK	(7) No Lock																

Table 6- 13: SDI Option 1S diagnostic test descriptions (Cont.)

Test name	Description
<p>I2C and EDH Chips</p> <p>PCF8584 Rd/Wrt</p> <p>EDH Chip</p>	<p>The I2C chip is a Philips PCF8584 device that provides a 2 wire interface by which ICs can communicate with each other. The CPU in the VM700T uses this device to communicate with the Gennum GS9001 Error Detection and Handling Coprocessor (EDH) chip. The I2C interface is tested first, and if it works, then it is used to do a limited amount of communication with the EDH chip.</p> <p>There is only one register in the I2C chip (U59) which can be both read and written (all others are read only or write only). This register is tested by writing and reading back a series of test patterns. If there is a mismatch, a message is generated to the console to indicate the expected and actual values that were read back from the chip.</p> <p>If the previous test passes, then this test is run, else it is set to N/A. Since the interface to the EDH chip (U41) is a 2-wire serial interface, the only point of the test is to exchange some data with the device to see if it can be written and read. Consequently, we write and read back the TV standard bits in the EDH chip (using the I2C interface). If this is successful, the test passes.</p>
<p>All Low/High Bits</p> <p>Force Low Data</p> <p>Force High Data</p>	<p>The SDI board can be forced to drive all (10) bits in the data acquisition to low or high via special test modes. This group of tests exercises this ability. External signals must be connected to both channels in order to have a source of data which is not all low or high, so when we force all low or high, we can do so under controlled conditions.</p> <p>For this test, the diagnostic asserts the FORCE_LOW* signal which is an input to pin 8 on U139, U140, U141 and U43. This causes these devices to drive their outputs to the low state. The a data acquisition is done, and the acquisition memory checked to make sure that all the bits in the data path are low. If they are, the test passes. Otherwise, a fail is flagged, and for each non-zero bit, a message is generated on the console.</p> <p>The diagnostic forces all data bits from the SDI board to the high state by tri-stating the data drivers in PALs U35 and U30. This allows R643, R647, R651, R655, R644, R648, R652, R656, R645, R649, R653, R657, R646, R650, R654, and R658 to pull the data path high. After setting up this way, the data is acquired and checked to make sure all bits are high. If so, the test passes. Otherwise, a test failure is flagged, and for each data bit that is not high, a message is generated to the console.</p>

Table 6- 13: SDI Option 1S diagnostic test descriptions (Cont.)

Test name	Description
<p>SDI Digital Paths</p> <p>Channel A Signal/Lock</p> <p>Channel A Hsync</p> <p>Channel A Data Path</p> <p>Channel B Signal/Lock</p> <p>Channel B Hsync</p> <p>Channel B Data Path</p>	<p>This group checks the operation of the digital data paths on the SDI board, and consists of the following tests:</p> <p>Three bits of information are generated by the front end to inform the rest of the system and the software about the status of the incoming signal. The first of these indicates that there is a signal present, and is generated at U61.19 (for Channel A) and U162.19 (for Channel B). The second bit originates at pin 4 of the same part but is read by the software at the other side of U160 (for Ch. A) and U161 (for Ch. B). If both of these bits is asserted (high), then the diagnostic will conclude that a valid signal is present on the corresponding channel. When this is the case, the Channel A/B Signal/Lock test will show pass, and the next 2 tests will be performed. Otherwise, all three tests for that channel will be flagged as N/A.</p> <p>If a valid signal is detected, then the output of U62.3 (for Ch. 1 or U163.3 for Ch. 2) is sampled (through a 33 ohm resistor, R777 or R820) to determine if the deserializer chip (the Gennum 9000) has detected HSYNC errors. If so, this test FAILS, and the data path test is not performed (flagged N/A). If there are no HSYNC errors, then the data path test is conducted.</p> <p>The output of the Gennum 9000 deserializer (U62 for Ch. 1, U163 for Ch. 2) is routed to the data acquisition system and a data acquisition is performed. Each of the 10 bits of the data path is checked for movement, and a message is generated to the console for each bit that is stuck high or low. Note that these data bits, after they come out of the Gennum part, are multiplexed through U35 (CHA data/CHB Data input, VIDEO MUX output). Next, this video mux output is multiplexed again through U30, coming out of this device as VIDEO_OUT (9..0). This is what drives the TTL-ECL drivers (U139, U140, U141 and U43) for eventual transmission to the Acquisition/Controller board.</p> <p>The above three tests are repeated for channel B, with the same pass/fail criteria and test execution constraints.</p>
<p>SDI Eye Path</p>	<p>There is only one test in this group. The SDI board is configured for an eye diagram acquisition. The data muxes are set up to pass "Channel C" data through to the acquisition board, and an eye acquisition is performed. The 10 data bits are checked for movement, and any bits that are stuck high or low are reported to the console. If there is no signal on Channel A (as determined by checking the signal present/locked bits), this test will be flagged N/A.</p>
<p>SDI Jitter Path</p>	<p>There is only one test in this group. The SDI board is configured for a jitter acquisition. The data muxes are set up to pass "Channel C" data through to the acquisition board, and a jitter acquisition is performed. The 10 data bits are checked for movement, and any bits that are stuck high or low are reported to the console. If there is no signal on Channel A (as determined by checking the signal present/locked bits), this test will be flagged N/A.</p>

Table 6-13: SDI Option 1S diagnostic test descriptions (Cont.)

Test name	Description
SDI Wander Path	<p>This test checks the drift rate circuitry. The DRIFT_SRC bits (2..0) into pins 9, 10, 11 of U129 are set (via control register 1) to route CTRL_STEP (into pin 13) out to the outputs. DRIFT_CLK<2..0> is also set to select pin 2 of U130 (CHOPPER_EN) to the output (pin 5). Following this, 10000 cycles of the following sequence are performed:</p> <p>Set U129.13 high Set U130.2 high Set U129.13 low Clock U130.2 twice</p> <p>This causes the counters U132 and U133 to cycle through all their states several times, and for each of these states to be latched into U24. The output of U24 is routed to the data acquisition. After the acquisition has been performed, the data is checked to ensure that all 8 bits are moving. If so, the test passes. Otherwise, a message is generated to the console for each bit that is stuck low or high.</p>
Supermux Tests Fsyncs Lsyncs Blanking Bits Eye Flags	<p>Acquired data consists of a 10-bit data sample and 4 flag bits captured synchronously. Each of these flag bits can be fed by a variety of sources, such as line and frame sync pulses from either channel, eye rise/fall flags, etc. This multiplexing is performed by four muxes that are implemented in a PLD (U35). Several of these bits are available as inputs to more than one of these 4 muxes. The supermux tests exploit this redundancy. For each supermux test, we set up the mux selector to route the same bit to as many of the flag bits as possible, and then we examine the flag bits in the acquired data to verify that the same state is acquired in all the flag bits.</p> <p>Even though this description is grouped under one paragraph, the tests themselves had to be broken out into separate groups because the diagnostic framework has a time limit for the completion of each test. These groups, and the bits checked within each, are as follows:</p> <p>Checks frame sync A and B on Flags 3, 2, 1 and 0 Checks line sync A and B on Flags 3, 2, 1, and 0 Checks horiz/vert blanking bits on Flags 3, 2, 1 and 0 Checks the eye rise flag on Flags 3 and 2.</p>

Options

This section provides a brief summary of the available options for the VM700T Video Measurement Set at the time of printing of this manual. The Standards options refers to the television standard, either Option 01 (NTSC) or Option 11 (PAL), for which measurements are made. The application options make the appropriate measurements for the installed television standard.

Standard Options (Option 01 and Option 11)

When ordering the VM700T, you may specify the video standard you want your instrument to be capable of making measurement with. Option 01 is the System M NTSC video standard and Option 11 is the System BG/i PAL video standard. You may also order the VM700T with both standards installed or purchase a firmware upgrade to add a standard to make the VM700T a dual-standard Video Measurement Set.

Application Options (Option 1G, Option 20, Option 21, Option 30, Option 42)

The application options provide additional measurement capabilities not provided in the standard Option 01 (NTSC) or Option 11 (PAL) firmware as part of the base instrument measurements. These may be ordered as part of the original purchase or added later with an option upgrade.

2T Echo and Rounding of Black and White Measurement (Option 1G)

The VM700T Video Measurement Set Option 1G (2T Echo and Rounding of Black & White) gives you access to two measurements, named Echo and Rounding Errors, respectively. Echo determines multipath distortion. Rounding Errors measures rounding of the black-to-white and white-to-black signal transitions.

Teletext Measurement (Option 20)

The VM700T Video Measurement Set Option 20 (Teletext) gives you access to two measurements: Teletext and SoundInSync. These measurement applications determine various parameters related to the transmission of digital information in the vertical interval and in the sync pulse, respectively.

Camera Measurements (Option 21)

The following Camera Testing measurements are available with Option 21 of the VM700T Video Measurement Set.

- Colorimetry measures the color fidelity of a camera's output (CCD or tube cameras).
- Defects identifies defective cells in CCD devices (CCD cameras only).

- Detail measures the artificial sharpening transitions added to the video in both the horizontal and vertical directions as a percentage of transition amplitude (CCD or tube cameras).
- Fixed Pattern Noise identifies unwanted signal non-uniformities correlated to CCD cells (CCD cameras only).
- Frequency Response measures the degradation in waveform amplitude as the frequency of modulation increases (CCD or tube cameras). Measures aliasing components for CCD cameras.
- Gamma measures the input-to-output light transfer characteristic of an imaging or display device (CCD or tube cameras).
- Geometry and Registration measures geometric distortions in camera imaging elements (CCD or tube cameras).
- Shading measures variation in camera output luminance levels when light input is constant (CCD or tube cameras).
- Vertical Smear measures the camera's ability to handle excess light (CCD cameras only).

Component Measurements (Option 30)

Option 30 (Component) of the VM700T Video Measurement Set gives you access to the following 12 measurements:

- Bowtie measures timing and amplitude differences.
- Channel Delay measures timing and amplitude differences as does Bowtie, but it works with signals containing jitter.
- ColorBar measures the Y, Pb, and Pr amplitudes of each chroma packet.
- K_Factor measures K-2T, K-5T, and Pulse-to-Bar ratio on component input signals.
- Level Meter monitors peak-to-peak amplitude of a component signal.
- Lightning displays two XY graphs on the screen.
- Luminance NonLinearity measures luminance nonlinear distortion.
- Component Multiburst measures frequency response.
- Noise Spectrum measures noise level and performs spectrum analysis.
- Overlay displays stacked or superimposed Y, Pb, and Pr component inputs.
- Parade displays side-by-side Y, Pb, and Pr component inputs.
- Vector provides an XY display of the Pb and Pr components.

**Audio/Video
Timing Measurement
(Option 42)**

The Audio/Video Timing measurement option (Option 42) of the VM700T is part of a system that measures the timing difference between audio and video portions of a program that arrive from different transmission paths. This feature is used in conjunction with the VITS200 NTSC or VITS201 PAL insertion generators and the ASG100 or ASG140 Audio Signal Generators that are also equipped with the Audio/Video Timing measurement. The VM700T must have either Option 40 or Option 41 installed to operate with the Option 42 firmware.

Audio Options (Option 40 and Option 41)

The VM700T audio measurement options expands the power of the VM700T Video Measurement Set to include comprehensive audio measurement capabilities.

Option 40 and Option 41

VM700T Option 40 and Option 41 capabilities include:

- automated and manual audio measurements
- audio spectral analysis with harmonic analyzer
- stereo monitoring
- real-time display of audio parameters
- multitone testing

These options also enable the VM700T to continuously monitor audio test lines for the presence of a test sequence designed for automated testing (the TEK sequence). The audio option tests to ANSI standard T1.502-1988, EIA/TIA-250-C, or CCITT Recommendation O.33.

The audio results received with automatic monitoring can be included in the VM700T Auto Mode video measurements display, with the time and date of the last sequence received. Timed reports and the logging of results can be performed automatically. Also, a file in the VM700T Measurement Results directory is updated each time an audio auto test sequence is received and measured.

Option 40 has two stereo input channels connected through mini-XLR connectors. Two mini-XLR adapters are provided to make signal connections to the inputs. Option 41 provides for three stereo input channels connected through a male DB 37 connector. A female DB 37 connector is provided with Option 41 to use for fabricating the interconnecting cable that applies the signals to be measured to the three stereo inputs of the VM700T. Either Option 40 or Option 41 may be installed in the VM700T, not both.

Serial Digital Interface (Option 1S)

Option 1S provides the capability to display, capture, and analyze 270 Mbit, 525-line and 625-line serial component, 143 Mbit serial composite, and 360 Mbit serial component digital video signals. The Option 1S hardware consists of an SDI circuit board that installs into the right-side card cage, a two-board input assembly that mounts onto the measurement set rear panel, updated instrument firmware, and several interconnecting cables.

The Option 1S rear panel connectors include two SDI inputs (one loopthrough and one internally terminated in 75 Ω), a buffered SDI output of one of the SDI input channels, an AES/EBU digital audio input, a Longitudinal Time Code input for time stamping logged error files, and an analog loopthrough input to be used for a timing reference signal.

Option 1S provides the following key features:

- Automatic analysis of 270 Mbit component, 143 Mbit composite, and 360 Mbit component serial digital video signals
- Continuous real-time format analyzer with event logging and frame capture (captured frames can be downloaded to a PC)
- Longitudinal Time Code input for time stamping error events
- External and embedded digital audio measurements including audio to video timing measurements
- Conformance testing to SMPTE 259M and SMPTE RP-165 digital error detection and reporting
- Ancillary data analysis with data distribution display
- Relative to reference mode allowing signal comparisons
- Digital video wander measurements

GPIB Interface (Option 48)

This option provides the hardware and firmware to support a GPIB interface for remote control of the VM700T or hard copy output to a GPIB printer.

White Phosphor CRT (Option 74)

This option provides a display module with a white phosphor CRT instead of the standard green phosphor when a new instrument is ordered with Option 74 from the factory. All the display module adjustments are the same as those for the standard CRT.

Cabinet and Mounting Options (Option 1C, VM7FR1, VM7FC1)

Cabinet Version (Option 1C)	This option provides the VM700T in a cabinet version from the factory. The standard order configuration is rack mounted.
Rack Mounting Kit (VM7FR1)	This field-installable option provides a rack mounting conversion kit for the VM700T. This kit converts a cabinetized measurement set to permit a rack mounting installation.
Cabinetizing Kit (VM7FC1)	This field-installable option provide a conversion kit to install a cabinet on a rack mounted measurement set.

Auxiliary Software Options (VMBKUP, VMT, VMREMGR)

VMBKUP	This software package assists in backing up the VM700T user-created files. These files can be reloaded to the same instrument or to another VM700T to generate a common set of configuration files.
VMT	This software package assists in remote control of the VM700T using a personal computer. The software also allows you to capture text and graphics.
VMREMGR	This software package aids you in handling the graphic displays and transferring them to a personal computer for filing, display, or printing.

Optional Accessories

Table 7-1: Optional accessories

Accessory	Description	Tektronix part or product number
Service manual	VM700T servicing information	070-9630-XX
GPIB accessories	Available with Option 48	
Cables	1 m, double-shielded 2 m, double-shielded 3 m, double-shielded	012-0991-01 012-0991-00 012-0991-02
GURU II+	GPIB User's Resource Utility for the IBM Personal Computer. This package includes software and manual plus National PC2A GPIB controller board; GPIB cable; software on floppy diskettes.	S3FG100

Power Cord Options

Table 7-2: Optional power cords

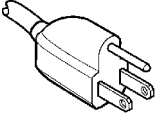
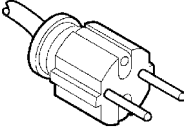
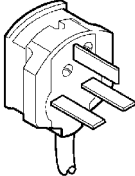
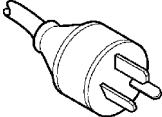
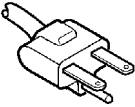
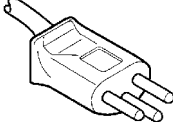
Plug configuration	Normal usage	Option number
	North America 125 V/15A Plug NEMA 5-15P	Standard
	Europe 230 V	A1 ¹
	United Kingdom 230 V	A2 ¹
	Australia 230 V	A3
	North America 230 V	A4
	Switzerland 230 V	A5

¹ European and United Kingdom power cord options A1 and A2 also require the VM700T Power Line Conditioner box for operation in EU countries. The power line conditioner prevents harmonic emissions from the VM700T power supply from entering the commercial power mains.

Replaceable Electrical Parts

Individual electrical components are not listed because component-level repair is not supported in VM700T Video Measurement Set.

The electrical modules for this instrument are listed in the *Replaceable Mechanical Parts* list.

Diagrams

The block diagram and interconnection diagram are provided to assist in identifying the interaction between modules in troubleshooting to the module level. Use the exploded view diagrams in the *Replaceable Parts List* section to locate the modules installed in the VM700T.

Block Diagram

Each module in the instrument is assigned an assembly number (for example, A20). The assembly number appears on the block diagram. The overall block diagram is at the board level. More detailed block diagrams of the modules are shown in the *Theory* section with the discussion of the module circuit operation.

Interconnection Diagram

The interconnection diagram shows the connections made between modules to assist in tracing the signal and power distribution routes.

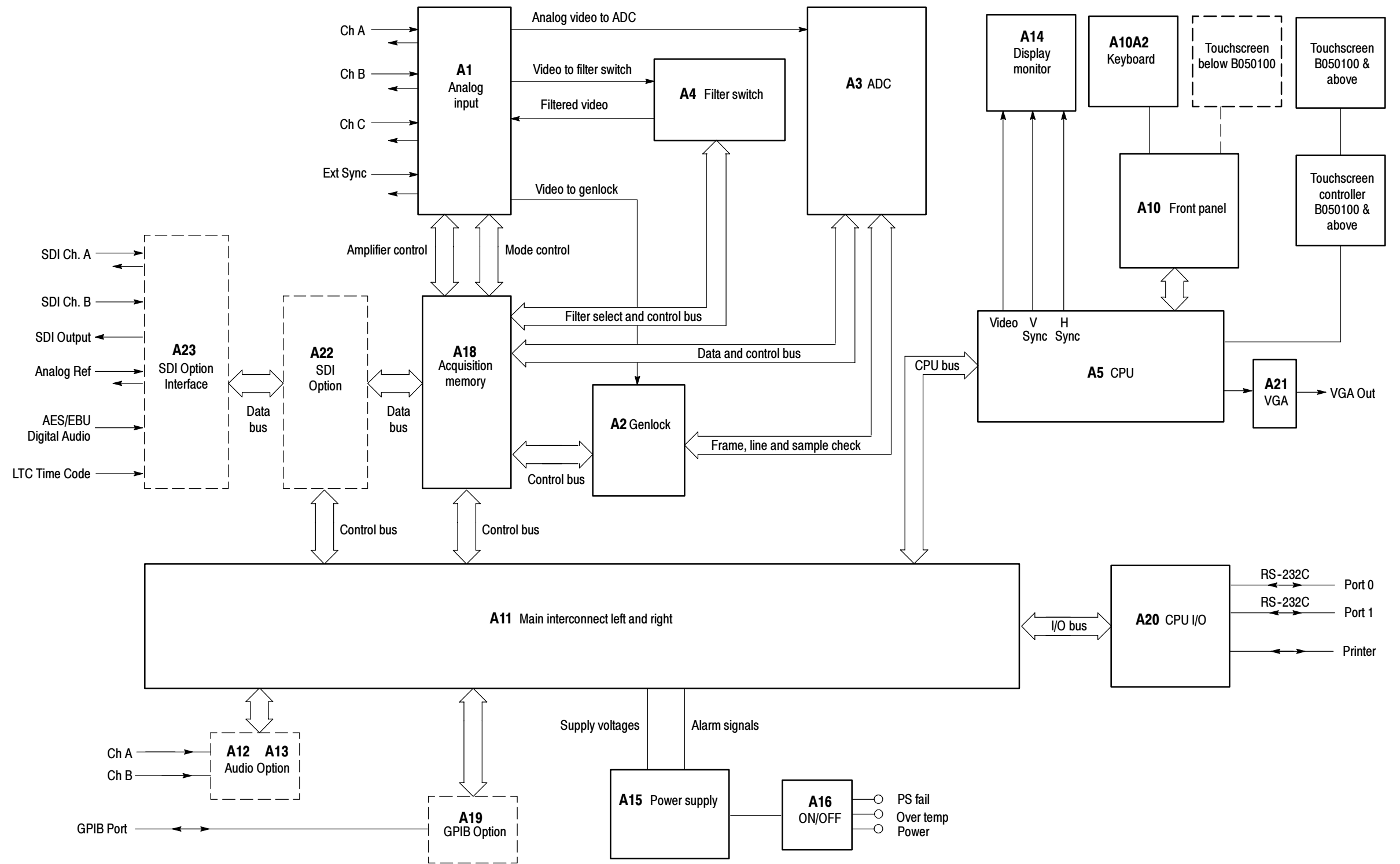

Figure 9- 1: VM700T Video Measurement Set simplified block diagram

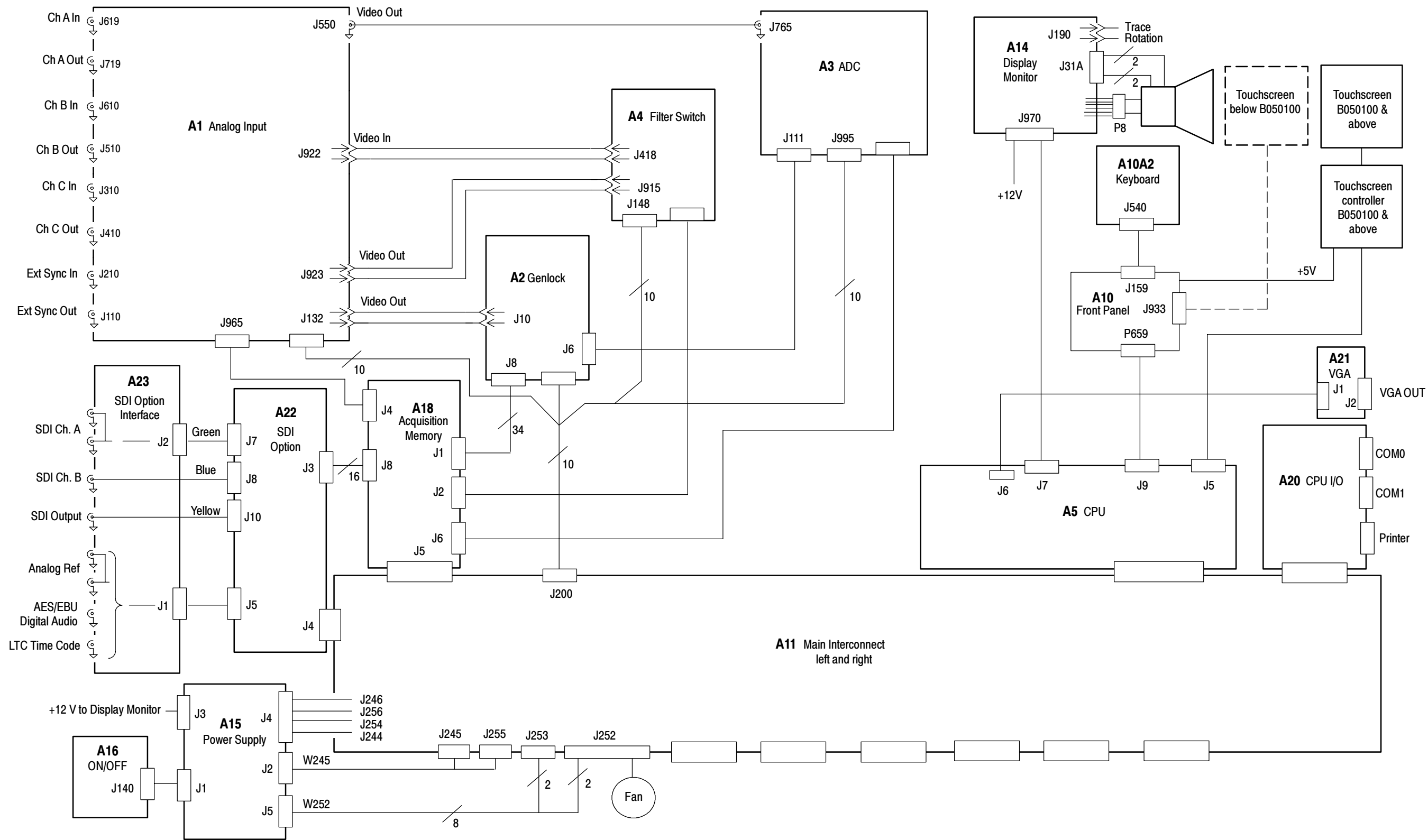

Figure 9-2: VM700T Video Measurement Set interconnection diagram

Replaceable Mechanical Parts

This section contains a list of the replaceable mechanical components for the VM700T Video Measurement Set. The replaceable modules are also included in this parts list as well as in the Replaceable Electrical Parts List. Use this list to identify and order replacement parts.

Using the Replaceable Mechanical Parts List

The tabular information in the Replaceable Mechanical Parts List is arranged for quick retrieval. Understanding the structure and features of the list will help you find all of the information you need for ordering replacement parts. The following table describes the content of each column in the parts list.

Parts list column descriptions

Column	Column name	Description
1	Figure & index number	Items in this section are referenced by figure and index numbers to the exploded view illustrations that follow.
2	Tektronix part number	Use this part number when ordering replacement parts from Tektronix.
3 and 4	Serial number	Column three indicates the serial number at which the part was first effective. Column four indicates the serial number at which the part was discontinued. No entries indicates the part is good for all serial numbers.
5	Qty	This indicates the quantity of parts used.
6	Name & description	An item name is separated from the description by a colon (:). Because of space limitations, an item name may sometimes appear as incomplete. Use the U.S. Federal Catalog handbook H6-1 for further item name identification.
7	Mfr. code	This indicates the code of the actual manufacturer of the part.
8	Mfr. part number	This indicates the actual manufacturer's or vendor's part number.

Abbreviations Abbreviations conform to American National Standard ANSI Y1.1-1972.

Mfr. Code to Manufacturer Cross Index The table titled Manufacturers Cross Index shows codes, names, and addresses of manufacturers or vendors of components listed in the parts list.

Replaceable parts list

Fig. & index number	Tektronix part number	Serial no. effective	Serial no. discont'd	Qty	Name & description	Mfr. code	Mfr. part number
10-1-1	331-0508-06		B049999	1	SCALE,CRT:FRAME,FRONT FINISHED	OJR05	331-0508-06
	331-0508-07	B050100		1	SCALE,CRT:FRAME,FRONT FINISHED	7X318	ORDER BY DESC
-2	211-0517-00			3	SCREW,MACHINE:6-32 X 1.0,PNH,STL POZ	TK1907	211-0517-00
-3	210-0055-00			3	WASHER,LOCK:#6 SPLIT,0.031 THK,STL CDPL	86928	ORDER BY DESC
-4	210-0802-00			3	WASHER,FLAT:0.15 ID X 0.312 OD X 0.032,STL	86928	ORDER BY DESC
-5	Not used						
-6	378-0322-00			2	FILTER,AIR:FOAM,#1	85471	378-0322-00
-7	354-0691-01			4	O-RING:0.196 OD X 0.070 ID,ETHYLENE PROPYL	02697	2-004 E803-70
-8	378-0323-00			1	FILTER,AIR:FOAM,#2,	85471	378-0323-00
-9	354-0691-01			2	O-RING:0.196 OD X 0.070 ID,ETHYLENE PROPYL	02697	2-004 E803-70
-10	378-0325-00			1	FILTER,AIR:FOAM,#4,	85471	378-0325-00
-11	354-0691-01			2	O-RING:0.196 OD X 0.070 ID,ETHYLENE PROPYL	02697	2-004 E803-70
-12	378-0324-00			1	FILTER,AIR:FOAM,#3,	85471	378-0324-00
-13	354-0691-01			4	O-RING:0.196 OD X 0.070 ID,ETHYLENE PROPYL	02697	2-004 E803-70
-14	333-3521-00			1	PANEL,FRONT:ON/OFF	0KB05	ORDER BY DESC
-15	671-0111-00			1	CKT BD ASSY:ON/OFF (A16)	80009	671-0111-00
-16	210-0405-00			2	NUT,PLAIN,HEX:2-56 X 0.188,BRS CD PL	73743	12157-50
-17	210-0001-00			2	WASHER,LOCK:#2 INTL,0.013 THK,STL CD PL	78189	1202-00-00-0541C
-18	174-1163-01			1	CA ASSY,SP,ELEC:5,26 AWG,7.7 L,RIBBON	9M860	174-1163-01
-19	672-1299-08	B010100	B010139	1	CKT BD ASSY:FRONT PANEL (A10)	80009	672-1299-08
	672-1299-09	B010140		1	CKT BD ASSY:FRONT PANEL (A10)	80009	672-1299-09
-20	212-0040-00			7	SCREW,MACHINE:8-32 X 0.375,FLH,STLPOZ	TK0435	ORDER BY DESC
-21	366-2159-01			1	KNOB:TV GRAY,SCROLL 1.243 ID X 1.4 OD X 0.42 H	TK1163	366-2159-01
-22	333-4215-00			1	PANEL,FRONT:FRONT PANEL,LEXAN	0KB05	333421500
-23	211-0658-00			1	SCR,ASSEM WSHR:6-32 X 0.312,PNH,STL,POZ	93907	821-12790-024
-24	-----			1	CKT BD ASSY:KEY (A10A2). FOR REPLACEMENT SEE A10		
-25	211-0507-00			6	SCREW,MACHINE:6-32 X 0.312,PNH,STL,POZ	TK0435	ORDER BY DESC
-26	-----			1	CKT BD ASSY:FRONT PANEL(A10A1) FOR REPLACEMENT SEE A10		
-27	211-0658-00			6	SCR,ASSEM WSHR:6-32 X 0.312,PNH,STL,POZ	93907	821-12790-024
-28	407-4289-00			1	BRACKET,KEY BD:407-3922-00 & 337-3662-00	80009	407-4289-00
-29	337-3662-00			1	SHIELD,ELEC:4.96 L,BE CU,CLIP ON,RIGHT	30817	97-0605-02-X
-30	657-0098-03			1	MODULAR SUBASSY:W/TOUCH PANEL (A14 STD)	80009	657-0098-03
	657-0099-03				MODULAR SUBASSY:W/TOUCH PANEL (OPT 74)	80009	657-0099-03
-31	Not used						
-32	440-3786-01		B049999	1	PANEL,CONDCT:ETCHED,CONVEX TYPE 0927	80009	440-3786-01
	119-6974-00	B050100		1	TOUCH PANEL	80009	119-6974-00
-33	213-1014-00			4	SCREW,TPG,TF:10-16 X 0.5,HEX HD,STL,ZN PL	3M099	ORDER BY DESC
-34	210-1454-00			4	WASHER,FLAT	5Y400	ORDER BY DESC
-35	210-1456-00			4	WASHER,SHLDR:0.5 DIA,W/0.203 DIA ID	TK0588	ORDER BY DESC
-36	348-0085-00			1	GROMMET,PLASTIC:GRAY,U-SHAPE,0.48 ID	0KBZ5	NA
-37	337-3448-00			1	SHIELD,ELEC:CRT	5Y400	ORDER BY DESC
-38	211-0507-00			12	SCREW,MACHINE:6-32 X 0.312,PNH,STL,POZ	TK0435	ORDER BY DESC
-39	220-0625-00			12	NUT,SHEET SPR:6-32,STLCLIP-ON TYPE	78553	C8090-632-24
-40	671-1922-02			1	CKT BD ASSY:DISPLAY (A14A1A1)	80009	671-1922-02

Replaceable parts list (cont.)

Fig. & index number	Tektronix part number	Serial no. effective	Serial no. discont'd	Qty	Name & description	Mfr. code	Mfr. part number
-41	441-1814-01			1	CHASSIS,CRT	0J260	441-1814-01
-42	337-3972-00			1	SHIELD,EMI:337-3648-00,337-3660-00,337-3661-00 ASSEMBLED	80009	337-3972-00
-43	212-0040-00			7	SCREW,MACHINE:8-32 X 0.375,FLH,100 DEG,STLPOZ	TK0435	ORDER BY DESC
-44	337-3660-00			1	SHIELD,ELEC:7.46 L,BE CU,CLIP ON, TOP	30817	97-0605-02-X
-45	337-3661-00			1	SHIELD,ELEC:6.46 L,BE CU,CLIP ON, LEFT	30817	97-0605-02-X
-46	174-0844-01			1	CA ASSY,SP,ELEC:8,22 AWG,16.18 L,RIBBON	9M860	174-0844-01
-47	407-3613-00			1	BRACKET,CA HSG:CABLE HOUSING BRACKET	0J260	ORDER BY DESC
-48	211-0661-00			1	SCR,ASSEM WSHR:4-40 X 0.25,PNH,STL,POZ	TK0435	ORDER BY DESC
-49	343-0088-00			2	CLAMP,CABLE:0.062 DIA,PLASTIC	80009	343-0088-00
-50	119-4258-04			1	PWR SPLY:IN 115/230 47-63 HZ, OUT 5V 40A, 15V 3A, -15V 3A,12V2.5A, -5.2V 8A, VAR FAN OUT 9-29V (A15)	80009	119-4258-04
-51	211-0507-00			6	SCREW,MACHINE:6-32 X 0.312,PNH,STL,POZ	TK0435	ORDER BY DESC
-52	210-0409-00			1	NUT,PLAIN,HEX:8-32 X 0.312,BRS CD PL		
-53	210-0458-00			1	NUT,PL,ASSEM WA:8-32 X 0.344,STL CD PL		
-54	212-0189-00			1	SCR,ASSEM WSHR:8-32 X 0.500,PNH,STL, CDPL,T-20 TORX DR,MACHINE	0KB01	ORDER BY DESC
-54	134-0245-00			1	PLUG,BTN:0.156 THK X 0.375 DIA,BLACK NYLON	28520	3059
-55	337-3653-00			1	SHIELD,ELEC:CABLE	5Y400	ORDER BY DESC
-56	211-0661-00			6	SCR,ASSEM WSHR:4-40 X 0.25,PNH,STL,POZ	TK0435	ORDER BY DESC
-57	407-4290-00			1	BRACKET,ELEC:407-3780-01,333-3532-00,337-366 9-00,337-3670-00 ASSEMBLED	80009	407-4290-00
-58	211-0504-00			5	SCREW,MACHINE:6-32 X 0.250,PNH,STL,POZ	TK0435	ORDER BY DESC
-59	337-3670-00			1	SHIELD,ELEC:CLIP ON,CU-BE,5.25 L	34641	337-3670-00
-60	337-3669-00			1	SHIELD,ELEC:CLIP ON,CU-BE,9.0 L	34641	337-3669-00
-61	337-3532-00			2	SHIELD,ELEC:BE CU,CLIP ON,1 X 2	80009	337-3532-00
-62	348-1583-00	B020100		1	SHLD GSKT,ELE FINGER TYPE,W/ MAGNEFIL, ADHESIVE,6L X 0.343, BECU, BRIGHT FINISH	30817	0097 0510 02
-64	211-0516-00	B030422		1	SCREW,MACH:6-32 X 0.875,PNH,STL CD PL,POZ	93907	ORDER BY DESC
-65	119-6934-00	B050100		1	TOUCH SCREEN CONTROLLER, ELO 2500S	6957	351077-000
-66	407-5001-00	B050100		1	BRACKET; TOUCH SCREEN CONTROLLER BD	TK1943	ORDER BY DESC
-67	211-0504-00	B050100		4	SCREW,MACHINE; 6-32 X 0.250,PNH,STL CD PL,POZ	0KB01	211-0504-00
-68	129-1602-00	B050100		4	SPACER,POST; 0.375 L	TK0588	ORDER BY DESC
-69	174-4948-00	B050100		1	CA ASSY:TOUCH SCREEN CONTROLLER BD	98661	174-4948-00
-70	211-0503-00	B050100		4	SCREW,MACHINE; 6-32 X 0.188,PNH,STL CD PL,POZ	0KB01	211-0503-00

Replaceable parts list (cont.)

Fig. & index number	Tektronix part number	Serial no. effective	Serial no. discont'd	Qty	Name & description	Mfr. code	Mfr. part number
10-2-1	672-1473-00			1	CKT BD ASSY:ADC (A3)	80009	672-1473-00
				1	CKT BD:ADC (A3A1)		
				1	CKT BD ASSY:ADC FILTER (A3A1A1)		
-2	211-0661-00			7	SCR,ASSEM WSHR:4-40 X 0.25,PNH,STL,POZ	TK0435	ORDER BY DESC
-3	Not used						
-4	Not used						
-5	Not used						
-6	Not used						
-7	Not used						
-8	Not used						
-9	211-0008-00			4	SCREW,MACHINE:4-40 X 0.25,PNH,STL	TK0435	ORDER BY DESC
-10	174-1164-00			1	CA ASSY,SP,ELEC:10,26 AWG,6.5 L,RIBBON	9M860	ORDER BY DESC
-11	174-0837-00			1	CA ASSY,SP,ELEC:10,18 AWG,14.05 L,RIBBON	00779	ORDER BY DESC
-12	672-1344-04	B010100	B010169	1	CKT BD ASSY:FILTER SW (A4)	80009	672-1344-04
	672-1344-06	B010170		1	CKT BD ASSY:FILTER SW (A4)	80009	672-1344-06
				1	CKT BD ASSY:FILTER SW WO FILTERS (A4A1)		
				1	CKT BD ASSY:CHROMA BANDPASS FILT (A4A1A1)		
				1	CKT BD ASSY:DIFF STEP FILTER (A4A1A2)		
				1	CKT BD ASSY:LF NOISE FILTER (A4A1A3)		
				1	CKT BD ASSY:IEEE LOWPASS FILTER (A4A1A4)		
				1	CKT BD ASSY:NTSC BW LIMIT FILTER (A4A1A5)		
-13	Not used						
-14	211-0661-00			6	SCR,ASSEM WSHR:4-40 X 0.25,PNH,STL,POZ	TK0435	ORDER BY DESC
-15	Not used						
-16	Not used						
-17	Not used						
-18	Not used						
-19	174-2008-00			1	CABLE ASSY,RF:75 OHM COAX,3.75 L,0-N	TK2469	174-2008-00
-20	337-3515-00			1	SHIELD,ELEC:POLYIMIDE	2K262	ORDER BY DESC
-21	671-3770-00	B010100	B010108	1	CKT BD ASSY:ANALOG INPUT (A1)	80009	671-3770-00
	671-3770-01	B010109		1	CKT BD ASSY:ANALOG INPUT (A1)	80009	671-3770-01
-22	211-0658-00			2	SCR,ASSEM WSHR:6-32 X 0.312,PNH,STL,POZ	93907	821-12790-024
-23	211-0661-00			8	SCR,ASSEM WSHR:4-40 X 0.25,PNH,STL,POZ	TK0435	ORDER BY DESC
-24	174-1165-00			2	CABLE ASSY,RF:75 OHM COAX,7.5 L	9M860	ORDER BY DESC
-25	174-0843-01			1	CA ASSY,RF:COAX,RFD,75OHM,RG174,RTANG,SMB	TK2469	174-0843-01
-26	672-1460-01	B010100	B010859	1	CKT BD ASSY:GENLOCK (A2)	80009	672-1460-01
	672-1460-02	B010860	B030531	1	CKT BD ASSY:GENLOCK (A2)	80009	672-1460-02
	672-1460-03	B030532		1	CKT BD ASSY:GENLOCK (A2)	80009	672-1460-03
-27	Not used						
-28	211-0661-00			7	SCR,ASSEM WSHR:4-40 X 0.25,PNH,STL,POZ	TK0435	ORDER BY DESC
-29	Not used						
-30	343-1331-02			1	HOLDER,PCB:CIRCUIT BOARD RETAINER,RIGHT	5Y400	343-1331-02
-31	211-0507-00			2	SCREW,MACHINE:6-32 X 0.312,PNH,STL,POZ	TK0435	ORDER BY DESC
-32	Not used						

Replaceable parts list (cont.)

Fig. & index number	Tektronix part number	Serial no. effective	Serial no. discont'd	Qty	Name & description	Mfr. code	Mfr. part number
-33	671-3922-01	B010100	B010212	1	CKT BD ASSY:ACQUISITION MEMORY (A18)	80009	671-3922-01
	671-3773-00	B010213	B019999	1	CKT BD ASSY:ACQUISITION MEMORY (A18)	80009	671-3773-00
	671-4108-00	B020100	B020230	1	CKT BD ASSY:ACQUISITION MEMORY (A18)	80009	671-4108-00
	671-4108-01	B020231	B031021	1	CKT BD ASSY:ACQUISITION MEMORY (A18)	80009	671-4108-01
	671-4108-02	B031022		1	CKT BD ASSY:ACQUISITION MEMORY (A18)	80009	671-4108-02
	671-4356-00	B030100	B031018	1	CKT BD ASSY:ACQUISITION MEM (A18), OPT 1S	80009	671-4356-00
	671-4356-01	B031019		1	CKT BD ASSY:ACQUISITION MEM (A18), OPT 1S	80009	671-4356-01
-34	Not used						
-35	671-2470-00	B010100	B010842	1	CKT BD ASSY:CPU (A5)	80009	671-2470-00
	671-2470-01	B010843	B029999	1	CKT BD ASSY:CPU (A5)	80009	671-2470-01
	671-2470-02	B030100	B030566	1	CKT BD ASSY:CPU (A5)	80009	671-2470-02
	671-2470-03	B030567		1	CKT BD ASSY:CPU (A5)	80009	671-2470-03
-36	343-1328-00			1	RTNR,CKT BOARD:LEFT	5Y400	ORDER BY DESC
-37	213-0919-00			1	THUMBSCREW:6-32,0.312 X 0.25 OD,SST	0KB01	213-0919-00
-38	354-0163-00			1	RING,RETAINING:TYPE E EXT,U/O 0.125 ID SFT	79136	5133-12ZD
-39	348-0102-00			1	PAD,CUSHIONING:13.76 X 0.67 X 0.188,RUBBER	2K262	ORDER BY DESC
-40	386-6667-00			2	PANEL,BLANK	80009	386-6667-00
-41	211-0661-00			3	SCR,ASSEM WSHR:4-40 X 0.25,PNH,STL,POZ	TK0435	ORDER BY DESC
-42	671-2799-00	B010100	B029999	1	CKT BD ASSY:I/O (A20)	80009	671-2799-00
	671-2799-01	B030100		1	CKT BD ASSY:I/O (A20)	80009	671-2799-01
-43	211-0661-00			1	SCR,ASSEM WSHR:4-40 X 0.25,PNH,STL,POZ	TK0435	ORDER BY DESC
-44	386-6662-00			1	PANEL,CKT BD:DOUBLE BLANK, W/OUT OPT 40 OR OPT 41	80009	386-6662-00
-45	Not used						
-46	672-1298-00		05-07-2001	1	CKT BD ASSY:MOTHER (A11)	80009	672-1298-00
	672-1298-01	05-07-2001		1	CKT BD ASSY:MOTHER (A11)	80009	672-1298-01
				1	CKT BD ASSY:BUS INTERCONNECT (A11A1)		
				1	CKT BD ASSY:MAIN INTERFACE,RIGHT (A11A2)		
				1	CKT BD ASSY:MAIN INTERFACE,LEFT (A11A3)		
-47	211-0661-00			6	SCR,ASSEM WSHR:4-40 X 0.25,PNH,STL,POZ	TK0435	ORDER BY DESC
-48	Not used						
-49	Not used						
-50	Not used						
-51	Not used						
-52	337-3658-00			1	SHIELD,ELEC:RIGHT,ALUMINUM	80009	337-3658-00
-53	211-0507-00			4	SCREW,MACHINE:6-32 X 0.312,PNH,STL,POZ	TK0435	ORDER BY DESC
-54	337-3656-00			1	SHIELD,ELEC:LEFT,ALUMIMUM	80009	337-3656-00
-55	211-0507-00			6	SCREW,MACHINE:6-32 X 0.312,PNH,STL,POZ	TK0435	ORDER BY DESC
-56	Not used						
-57	337-3739-00			1	SHIELD,ELEC:FILTER BOARD	5Y400	337-3739-00
-58	211-0101-00			4	SCREW,MACHINE:4-40 X 0.25,FLH,100 DEG,POZ	93907	ORDER BY DESC
-59	361-1590-00			2	SPACER,STANDOFF:0.250 DIA X 1.375 L NYLON	05791	NY-6941-0440-1.375-00
-60	351-0837-00			2	GUIDE,CKT BD:3.935 X 1.35 X 0.55,PLASTIC	0KBZ5	351-0837-00

Replaceable parts list (cont.)

Fig. & index number	Tektronix part number	Serial no. effective	Serial no. discont'd	Qty	Name & description	Mfr. code	Mfr. part number
-61	361-1591-00			2	SPACER,STANDOFF:0.250 DIA X 1.375 L	05791	A-6941-0440-1.375-22
-62	210-0405-00			4	NUT,PLAIN,HEX:2-56 X 0.188,BRS CD PL	73743	12157-50
-63	211-0001-00			1	SCREW,MACHINE:2-56 X 0.25,PNH,STL CD PL,POZ	93907	ORDER BY DESC
-64	174-3657-00			1	CA ASSY,SP:RIBBN,GENLOCK,HDI,34,32 AWG,10.0 L,2X17,0.05X0.1CTR,RCPT,CTR PLZ,BOTH ENDS	TK1547	174-3657-00
-65	174-3616-00			1	CA ASSY,SP:RIBBON,HDI,60,30AWG,10.7 L,2X30,CTR PLZ,0.5X0.1CTR,BOTH ENDS	TK1547	174-3616-00
					OPTION BOARDS (NOT SHOWN)		
	671-1787-05			1	CKT BD ASSY:AUDIO PROCESSOR (A12)	80009	671-1787-05
	671-1788-05			1	CKT BD ASSY:AUDIO ANALOG (A13)	80009	671-1788-05
	672-1348-06			1	CKT BD ASSY:TRIPLE-INPUTAUDIO ANALOG (A17)	80009	672-1348-06
				1	CKT BD ASSY:INPUT SELECTOR (A17A2)		
	671-2337-00			1	CKT BD ASSY:GPIB (A19)	80009	671-2337-00

Replaceable parts list

Fig. & index number	Tektronix part number	Serial no. effective	Serial no. discont'd	Qty	Name & description	Mfr. code	Mfr. part number
10-3-0	441-2113-00	B010100	B019999	1	CHASSIS ASSY:VM700T	80009	441-2113-00
	441-2113-01	B020100			CHASSIS ASSY:VM700T	80009	441-2113-01
-1	407-3649-00	B010100	B019999	1	BRKT,MTG,CRT:VM700T	0J260	407-3649-00
	407-3649-01	B020100		1	BRKT,MTG,CRT:VM700T	TK1943	407-3649-01
-2	212-0040-00			2	SCREW,MACHINE:8-32 X 0.375,FLH,STL,POZ	TK0435	ORDER BY DESC
-3	211-0507-00			3	SCREW,MACHINE:6-32 X 0.312,PNH,STL,POZ	TK0435	ORDER BY DESC
-4	426-1629-04			1	FRAME,CABINET:OPEN FR,8.75 FULL RACK	80009	426-1629-04
-5	213-0760-00			4	SCREW,TPG,TF:8-32 X 0.875,SPCL TAPTITE, T20	93907	ORDER BY DESC
-6	426-2204-00			1	FRAME SECT,CAB.:BOTTOM LEFT	0J7N4	426-2204-00
-7	211-0507-00			1	SCREW,MACHINE:6-32 X 0.312,PNH,STL,POZ	TK0435	ORDER BY DESC
-8	426-2203-00			1	FRAME SECT,CAB.:BOTTOM,RIGHT	0J7N4	426-2203-00
-9	211-0507-00			3	SCREW,MACHINE:6-32 X 0.312,PNH,STL,POZ	TK0435	ORDER BY DESC
-10	426-2202-00			2	FRAME SECT,CAB.:TOP RIGHT/LEFT	0J7N4	426-2202-00
-11	211-0507-00			7	SCREW,MACHINE:6-32 X 0.312,PNH,STL,POZ	TK0435	ORDER BY DESC
-12	124-0430-00			4	STRIP,TRIM:CORNER,W/STEP,20.0	61153	124-0430-00
-13	348-0632-00			4	SHLD GSKT,ELEK:FINGER TYPE,19.0 L,CNR LEFT	80009	348-0632-00
-14	348-0633-00			4	SHLD GSKT,ELEK:FINGER TYPE,19.0 L,CNR RIGHT	80009	348-0633-00
-15	343-1070-00			8	RTNR,ELEK SHLD:STAINLESS STEEL	0J7N4	343-1070-00
-16	386-6950-00			1	PANEL,REAR:REAR PANEL,0.100 ALUM	TK1943	386695000
-17	211-0507-00			11	SCREW,MACHINE:6-32 X 0.312,PNH,STL,POZ	TK0435	ORDER BY DESC
-17a	211-0504-00			2	SCREW,MACHINE:6-32 X 0.250,PNH,STL,POZ	TK0435	ORDER BY DESC
-18	213-0808-00			4	SCREW,TPG,TR:8-32 X 0.625 L,TAPTITE,STL,POZ	93907	ORDER BY DESC
-19	200-2222-00	B010100	B029999	1	GUARD,FAN:7912AD	81041	6-182-033
-20	119-2616-02			1	FAN:24VDC,28A,6.7W,W/LEADS 17.0L	0J260	119-2616-02
-21	212-0010-00			4	SCREW,MACHINE:8-32 X 0.625,PNH,STL,POZ	TK0435	ORDER BY DESC
-22	210-0458-00			4	NUT,PL,ASSEM WA:8-32 X 0.344,STL	73893	ORDER BY DESC
-23	348-0014-00			4	FOOT,CABINET:BLACK PHENOLIC	0KBZ5	ORDER BY DESC
-24	212-0010-00			4	SCREW,MACHINE:8-32 X 0.625,PNH,STLPOZ	TK0435	ORDER BY DESC
-25	348-0276-01			6	SHLD GSKT,ELEK:MESH TYPE,0.124 OD,7.442 L	80009	348-0276-01
-26	252-0571-00			1	NEOPRENE EXTR:CHAN,0.234 X 0.156	85471	ORDER BY DESC
-27	348-0150-00			1	GROMMET,PLASTIC:DK GRAY,U-SHAPE,0.66 ID	0KBZ5	NA
-28	351-0602-00			10	GUIDE,CKT BOARD:MAIN CHASSIS,POLYAMIDE	80009	351-0602-00
-29	351-0752-00			8	GUIDE,LIGHT:ACRYLIC GRATICULE	TK1908	PER TEK DRAWING
-30	407-3687-00			1	BRACKET,AIR:ALUMINUM	80009	407-3687-00
-31	211-0507-00			1	SCREW,MACHINE:6-32 X 0.312,PNH,STL,POZ	TK0435	ORDER BY DESC
-32	351-0817-00			5	GUIDE,CKT BD:NYLON,6.0 L	32559	DC-600
-33	348-0089-00			3	BUMPER,PLASTIC:0.312 DIA X 0.855 L,BLCK VINYL	0JR05	348-0089-00
-34	426-2221-06			1	FRAME ASSY	80009	426-2221-06
-35	333-4214-00			1	PANEL,REAR:REAR PANEL, 0.062 ALUM,	TK1943	333421400
-36	211-0507-00			6	SCREW,MACHINE:6-32 X 0.312,PNH,STL, POZ	TK0435	ORDER BY DESC
-37	671-3976-00			1	VGA CONNECTOR ASSY (A21)	80009	671-3976-00
-38	214-3903-01			2	SCREW,JACK:4-40 X 0.312 EXT THD,4-40 INT THD	0KB01	214-3903-01
-39	174-3652-00			1	CA ASSY:RBN,IDC,10,28 AWG,24.0 L,2X5 (VGA)	TK1547	174-3652-00
-40	337-4154-00	B020100		1	SHLD,ELEC:SLOTTED SHIELD,,8.626LX0.76W	TK2647	0097-0952-02
-41	407-4585-00	B030100		1	BRACKET,EMI:0.062 THK,RIGHT SIDE FRONT	TK1943	407-4585-00
-42	119-5870-00	B030100		1	FILTER,EMI:FAN,0.050 AL,5052-H3X,4.7 X 4.7	30817	119-5870-00
-43	212-0189-00			4	SCR,ASSEM WSHR:8-32 X 0.500,PNH,STL, T-20	0KB01	ORDER BY DESC

Replaceable parts list (cont.)

Fig. & index number	Tektronix part number	Serial no. effective	Serial no. discont'd	Qty	Name & description	Mfr. code	Mfr. part number
10-4-1	390-1020-03	B010100	B029999	2	CABINET,COVER:RACK MOUNT, TOP & BOTTOM	5Y400	390-1021-03
	390-1020-05	B030100		2	CABINET,COVER:RACK MOUNT, TOP & BOTTOM	5Y400	390-1021-03
-2	211-0658-00			4	SCR,ASSEM WSHR:6-32 X 0.312,PNH,STL,POZ	93907	821-12790-024
-3	390-1023-01	B010100	B029999	1	CAB.,SIDE ASSY:LEFT,RACK MOUNT	80009	390-1023-00
	390-1023-02	B030100		1	CAB.,SIDE ASSY:LEFT,RACK MOUNT	80009	390-1023-00
-4	211-0658-00			2	SCR,ASSEM WSHR:6-32 X 0.312,PNH,STL,POZ	93907	821-12790-024
-5	390-1022-01	B010100	B029999	1	CAB.,SIDE ASSY:RIGHT,RACK MOUNT	80009	390-1022-00
	390-1022-02	B030100		1	CAB.,SIDE ASSY:RIGHT,RACK MOUNT	80009	390-1022-00
-6	211-0658-00			2	SCR,ASSEM WSHR:6-32 X 0.312,PNH,STL,POZ	93907	821-12790-024
-7	367-0366-00			2	HANDLE,CARRYING:VM700T	80009	367-0366-00
-8	211-0755-00			4	SCREW,MACHINE:10-32 X 0.5,PNH,POZI	0KB01	211-0755-00
-9	213-0940-00			2	THUMBSCREW:10-32 X 1.15,0.375 OD,SST	TK0588	213-0940-00
-10	354-0025-00			2	RING,RETAINING:EXTERNAL,U/O 0.187 DIA SFT	2X013	IRR-7100-18-2B
-11	210-0894-00			2	WASHER,FLAT:0.19 ID X 0.438 OD X 0.031 POLTHN	86928	ORDER BY DESC
-12	351-0104-03			1	SL SECT,DWR EXT:12.625 L,W/O HARDWARE	06666	C-720-3
-13	210-0458-00			8	NUT,PL,ASSEM WA:8-32 X 0.344,STL (RACK MOUNT SIDE COVER)	73893	ORDER BY DESC
-14	351-0636-00			1	SLIDE,DWR,EXT:20.0 X 1.69,PAIR,R&L ,15" INTER.	06666	C-1252
-15	390-1020-04			1	CABINET, TOP:PORTABLE	5Y400	390-1020-04
-16	211-0658-00			2	SCR,ASSEM WSHR:6-32 X 0.312,PNH,STL,POZ	93907	821-12790-024
-17	390-1025-01	B010100	B029999	1	CAB.,SIDE ASSY:RIGHT,PORTABLE	5Y400	390-1025-01
	390-1025-02	B030100		1	CAB.,SIDE ASSY:RIGHT,PORTABLE	5Y400	390-1025-01
-18	211-0658-00			2	SCR,ASSEM WSHR:6-32 X 0.312,PNH,STL,POZ	93907	821-12790-024
-19	390-1028-01	B010100	B029999	1	CABINET,SIDE:LEFT,PORTABLE;W/HANDLE	5Y400	390-1028-01
	390-1028-02	B030100		1	CABINET,SIDE:LEFT,PORTABLE;W/HANDLE	5Y400	390-1028-01
-20	211-0658-00			2	SCR,ASSEM WSHR:6-32 X 0.312,PNH,STL,POZ	93907	821-12790-024
-21	390-1021-03	B010100	B029999	1	CABINET ASSY:BOTTOM,PORTABLE	5Y400	390-1021-03
	390-1021-05	B030100		1	CABINET ASSY:BOTTOM,PORTABLE	5Y400	390-1021-03
-22	211-0658-00			2	SCR,ASSEM WSHR:6-32 X 0.312,PNH,STL,POZ	93907	821-12790-024
-23	390-1021-01			1	CABINET ASSY:BOTTOM,PORTABLE	5Y400	ORDER BY DESC
-24	348-0879-01			4	FOOT,CABINET:BOTTOM,BLACK,POLYCARBONATE	TK1161	ORDER BY DESC
-25	211-0538-00			4	SCREW,MACHINE:6-32 X 0.312,FLH,100 DEG	93907	ORDER BY DESC
-26	348-0596-00			4	PAD,CAB.FOOT:0.69 X 0.255 X 0.06,PU	85471	348-0596-00
-27	200-3634-01			1	COVER,PROT:17.164 X 9.0,PLASTIC	80009	200-3634-01
-28	161-0066-00			1	CA ASSY,PWR:3.18 AWG,250V/10A,98 INCH,STR,IEC320,RCPT X NEMA 5-15P,US	0B445	ECM-161-0066-00
-29	011-0102-03			3	TERMN,COAXIAL:75 OHM,BNC	80009	011-0102-03
-30	348-0080-01			1	FOOT,CABINET:CHARCOAL GRAY,POLYURETHANE	0JR05	ORDER BY DESC
	174-3726-00			2	CABLE ASSY;ADAPTER, RS-232, 9-PIN FEMALE TO 25-PIN MALE	80009	174-3726-00
	070-9647-XX			1	MANUAL,TECH:USER,OP 01,11,NTSC AND PAL	TK2548	070-9647-XX
	070-9650-XX			1	MANUAL,TECH:PROGRAMMER,RS232	TK2548	070-9650-XX
	159-0005-00			1	FUSE,CART:3AG,3A,250V,30SEC,UL,CSA CERT	71400	MSL-3
	210-0863-00			1	WSHR,LOOP CLAMP:0.091 ID U/W 0.5 W CLP	85480	C191
	343-0136-00			1	CLAMP,LOOP:0.25 ID,PLASTIC	5Y400	343-0136-00

Replaceable parts list (cont.)

Fig. & index number	Tektronix part number	Serial no. effective	Serial no. discont'd	Qty	Name & description	Mfr. code	Mfr. part number
OPTIONAL ACCESSORIES							
-31	161-0066-09			1	CA ASSY,PWR:3,0.75MM SQ,250V/10A,99 INCH,STR,IEC320,RCPT,EUROPEAN	2W733	ORDER BY DESC
-32	161-0066-10			1	CA ASSY,PWR:3,1.0 MM SQ,250V/10A,2.5 METER,STR,IEC320,RCPT X 13A,FUSED UK PLUG (13A FUSE),UNI	TK2541	ORDER BY DESC
-33	161-0066-11			1	CA ASSY,PWR:3,1.0MM SQ,250V/10A,2.5 METER, STR,IEC320,RCPT,AUSTRALIA	80126	ORDER BY DESC
	118-8792-00			1	PRINTER:EPSON;SERIAL	80009	118-8792-00
	174-2740-00			1	CA ASSY,SP,ELEC:RS-232,4,28 AWG,72 INCH,25 POS FEMALE D-SUB X 25 POS MALE D-SUB	80009	174-2740-00
	018-0225-00			1	CKT BD ASSY:SERIAL INTERFACE CARD W/MANUAL (FOR EPSON SERIAL PRINTER)	80009	018-0225-00
	070-9630-XX			1	MANUAL,TECH:SERVICE MANUAL	80009	070-9630-XX
POWER LINE CONDITIONER (for use with Option A1 and A2 European Power Cord Options)							
	075-0705-XX			1	KIT INSTRUCT:EURO EMC POWER LINE COND	TK2548	075-0705-00
	119-6589-XX			1	FILTER ASSY:PWR SPLY LINE FILTER ADAPTER	80009	119-6589-00
	212-0518-00			4	SCREW,MACHI:10-32 X 0.312,PNH,STL CD PL,POZ	93907	ORDER BY DESC
	348-0430-00			4	BUMPER,PLASTIC:POLYURETHANE,BLACK	2K262	ORDER BY DESC
	407-4893-00			1	BRACKET,ADAPTOR:LINE COND BOX,0.050 AL	TK1943	407-4893-00

Replaceable parts list

Fig. & index number	Tektronix part number	Serial no. effective	Serial no. discont'd	Name & description	Mfr. code	Mfr. part number
10-5-1	671-4136-00	B030100	B030209	CKT BD ASSY:SDI BD,TESTED,389-2417-00 WIRED	80009	671-4136-00
	671-4136-01	B030210	B030411	CKT BD ASSY:SDI BD,TESTED,389-2417-00 WIRED	80009	671-4136-01
	671-4136-02	B030412	B030849	CKT BD ASSY:SDI BD,TESTED,389-2417-00 WIRED	80009	671-4136-02
	671-4136-03	B030850	B030919	CKT BD ASSY:SDI BD,TESTED,389-2417-00 WIRED	80009	671-4136-03
	671-4136-04	B030920		CKT BD ASSY:SDI BD,TESTED,389-2417-00 WIRED	80009	671-4136-04
-2	174-3779-00	B030100		CA ASSY,SP,ELEC:AQ/CONTROLLER, 34, 32 AWG,2.6 L,RIBBON	23633	174-3779-00
-3	174-3850-00	B030100		CA,ASSY,SP:ELECTRICAL,AMPLIFIER,IDC,10,28AW G,.050 RND,L 17.50,(2 X 5,FEMALE,RCPT,0.10 X 0.1	060D9	174-3850-00
-4	174-3848-00	B030100		CA ASSY:RF,RFD,CRIMP,1,75 OHM,L 7.50,SMB BOTH ENDS (AMP 414002-1) 1S	060D9	174-3848-00
-5	174-3891-00	B030100		CA,ASSY,RF:COAXIAL,RFD,1,75OHM,RG179,7.25 L	060D9	174-3891-00
-6	174-3849-00	B030100		CA ASSY:RF,DISCRETE,SER VID OUT,RFD,CRIMP,1,75 OHM,L 9.50	060D9	174-3849-00
-7	343-0549-00	B030100		STRAP,TIEDOWN,E:0.098 W X 4.0 L,ZYTEL	06383	PLT1M
-8	672-1504-00	B030100		CKT BD ASSY:INPUT & BNC,671-4237-00	80009	672-1504-00
-9	386-4247-00	B030100		PLATE,ADAPTER:ALUMINUM,TV GRAY	80009	386-4247-00
-10	211-0409-00	B030100		SCR,ASSEM WSHR:4-40 X 0.312,PNH,STL,CDPL,T-10 TORX DR	0KB01	211-0409-00
-11	333-4247-00	B030100		PANEL,REAR:AL 1S,SAFETY CONTROLLED	TK1943	333-4247-00
-12	159-5010-00	B030100		FUSE,SMD:7A,125V,FAST BLO,0.1X0.1X0.24,UL,CSA	75915	451007
-13	159-5011-00	B030100		FUSE,THRM,CHIP:SELF RESETTING FUSE,1.25A HOLD,2.5A TRIP AT 20 DWG C,15V MAX	06090	SMD125-2

Replaceable parts list

Fig. & index number	Tektronix part number	Serial no. effective	Serial no. discont'd	Name & description	Mfr. code	Mfr. part number
10-6-1	159-5014-00			FUSE:2.0A,125V,FAST BLOW,0.1 X 0.1 X 0.24,UL,CSA	75915	R451 002
6-2	159-5014-00			FUSE:2.0A,125V,FAST BLOW,0.1 X 0.1 X 0.24,UL,CSA	75915	R451 002
6-3	159-5014-00			FUSE:2.0A,125V,FAST BLOW,0.1 X 0.1 X 0.24,UL,CSA	75915	R451 002
6-4	159-5014-00			FUSE:2.0A,125V,FAST BLOW,0.1 X 0.1 X 0.24,UL,CSA	75915	R451 002
6-5	159-5011-00			FUSE,THRM,CHIP:SELF RESETTING FUSE,1.25A HOLD,2.5A TRIP AT 20 DWG C,15V MAX	06090	SMD125-2
6-6	159-0193-00			FUSE,WIRE LEAD:10A,60V,FAST BLOW,5 SEC,	61857	SP5-10A
6-7	159-0145-00			FUSE,WIRE LEAD:15A,32V,10 SECONDS	61857	SP7-15A
6-8	159-0145-00			FUSE,WIRE LEAD:15A,32V,10 SECONDS	61857	SP7-15A
6-9	159-5011-00			FUSE,THRM,CHIP:SELF RESETTING FUSE,1.25A HOLD,2.5A TRIP AT 20 DWG C,15V MAX	06090	SMD125-2
6-10	159-5011-00			FUSE,THRM,CHIP:SELF RESETTING FUSE,1.25A HOLD,2.5A TRIP AT 20 DWG C,15V MAX	06090	SMD125-2
6-11	159-5021-00			FUSE:15A,125V,FAST BLOW,0.1 X 0.1 X 0.24,UL,CSAR451 015	75915	R451 015
6-12	159-5010-00			FUSE,SMD:7A,125V,FAST BLOW,0.1 X 0.1 X 0.24,UL,CSA	75915	451007
6-13	159-0145-00			FUSE,WIRE LEAD:15A,32V,10 SECONDS	61857	SP7-15A
6-14	159-0059-00			FUSE,WIRE LEAD:5A,125V	61857	SPI-5A
6-15	159-0193-00			FUSE,WIRE LEAD:10A,60V,FAST BLOW,5 SEC	61857	SP5-10A
6-16	159-0194-00			FUSE,WIRE LEAD:5A,125V,0.125 SEC	61857	SP5-5A LEAD TAPE REEL
6-17	159-0205-00			FUSE,WIRE LEAD:1A,125V,5 SEC	61857	SP7-1A
6-18	159-0208-00			FUSE,WIRE LEAD:2A,125V,5 SEC	61857	SP5-2A
6-19	159-5011-00			FUSE,THRM,CHIP:SELF RESETTING FUSE,1.25A HOLD,2.5A TRIP AT 20 DWG C,15V MAX	06090	SMD125-2
6-20	159-5011-00			FUSE,THRM,CHIP:SELF RESETTING FUSE,1.25A HOLD,2.5A TRIP AT 20 DWG C,15V MAX	06090	SMD125-2

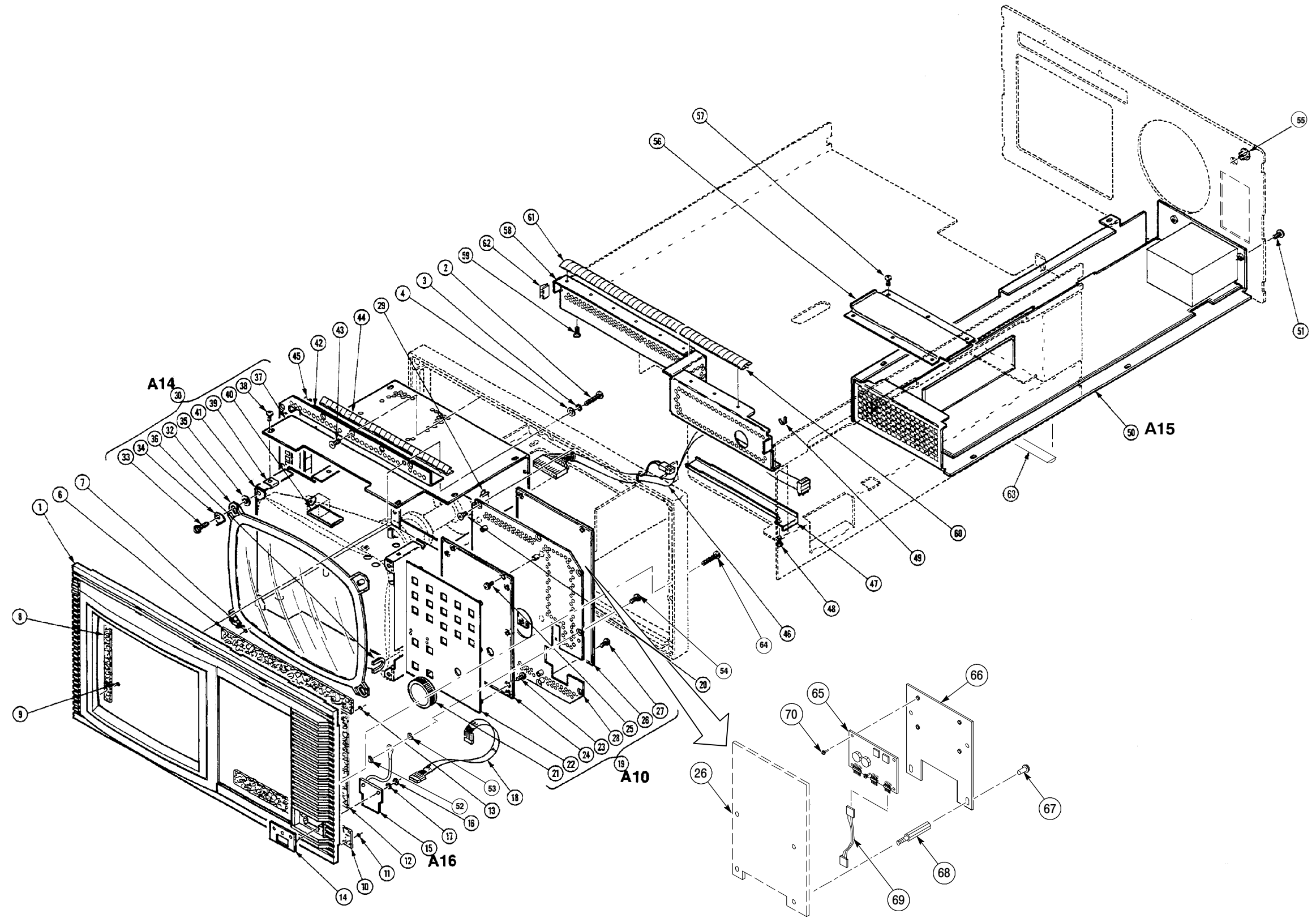

Figure 10- 1: Front assemblies and power supply

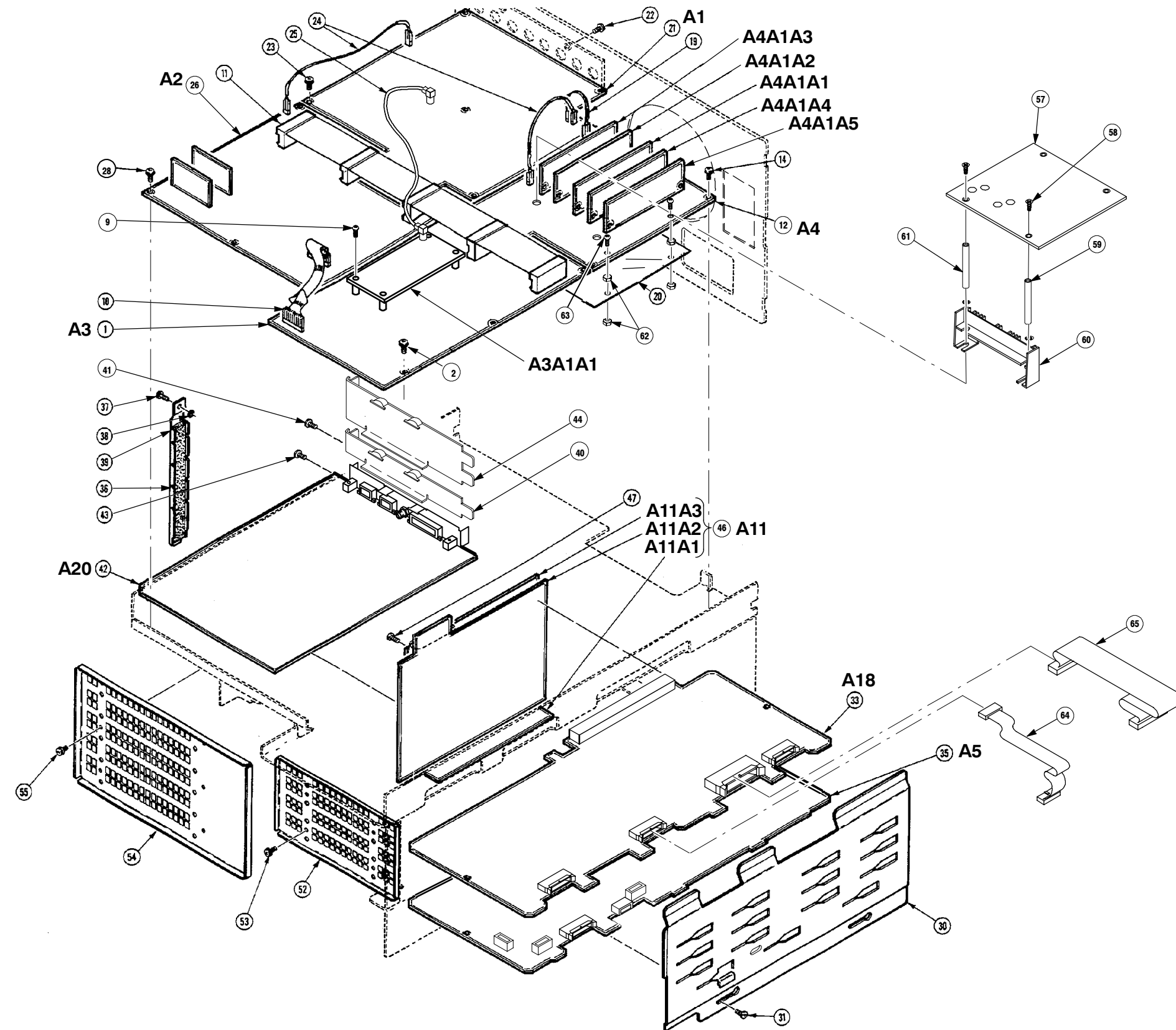

Figure 10-2: Circuit boards

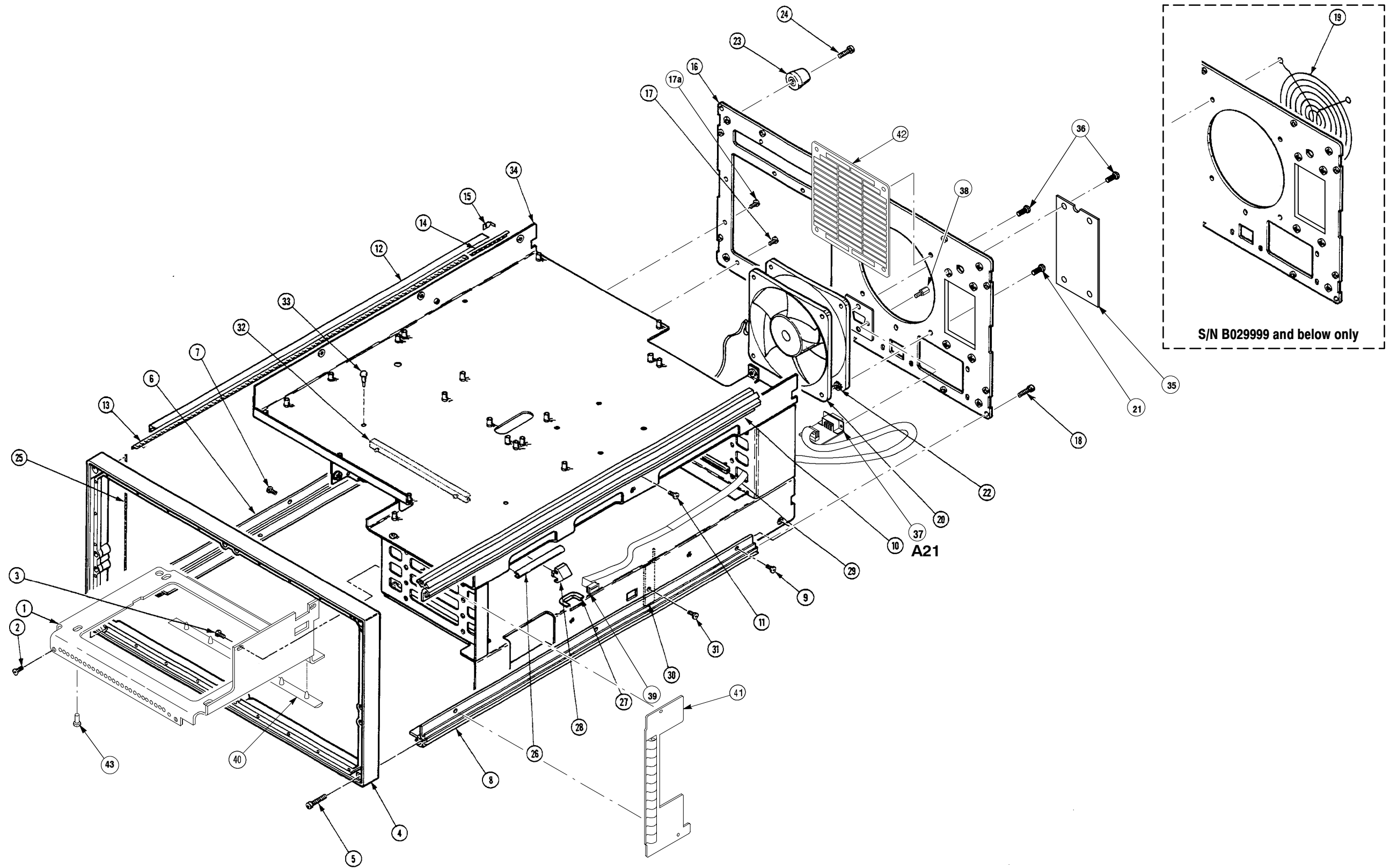

Figure 10-3: Chassis assembly

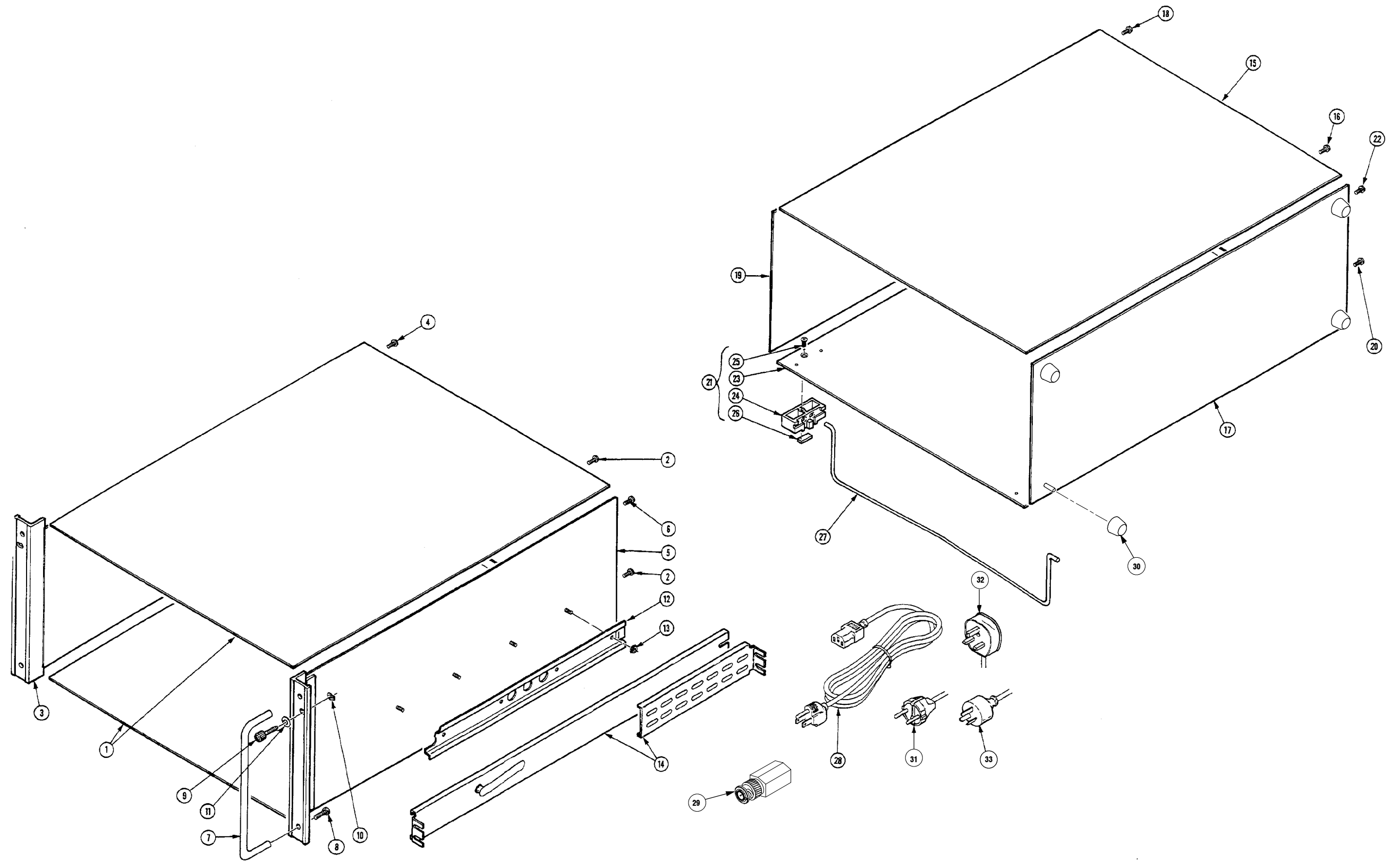

Figure 10-4: Cabinet and accessories

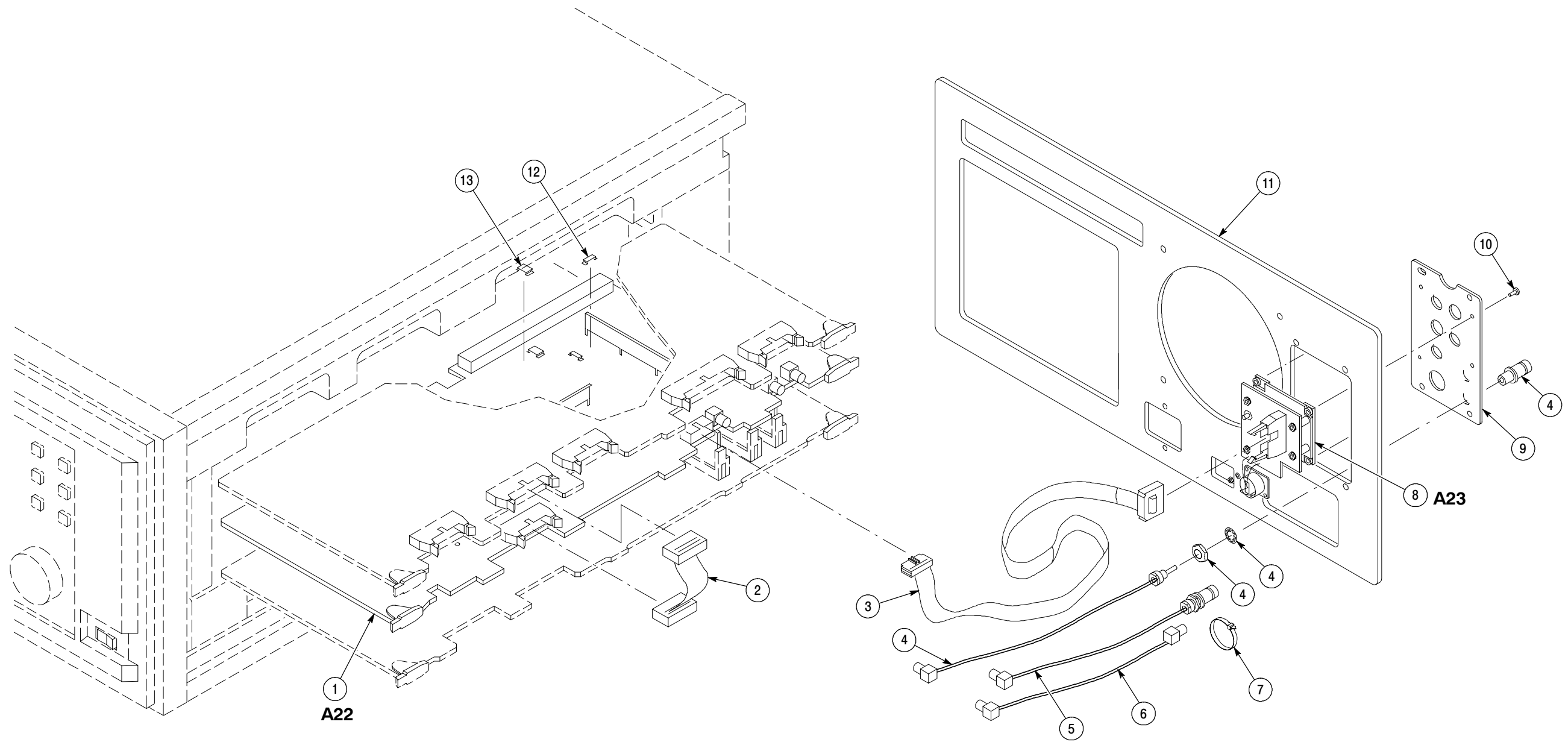

Figure 10-5: Option 1S circuit boards

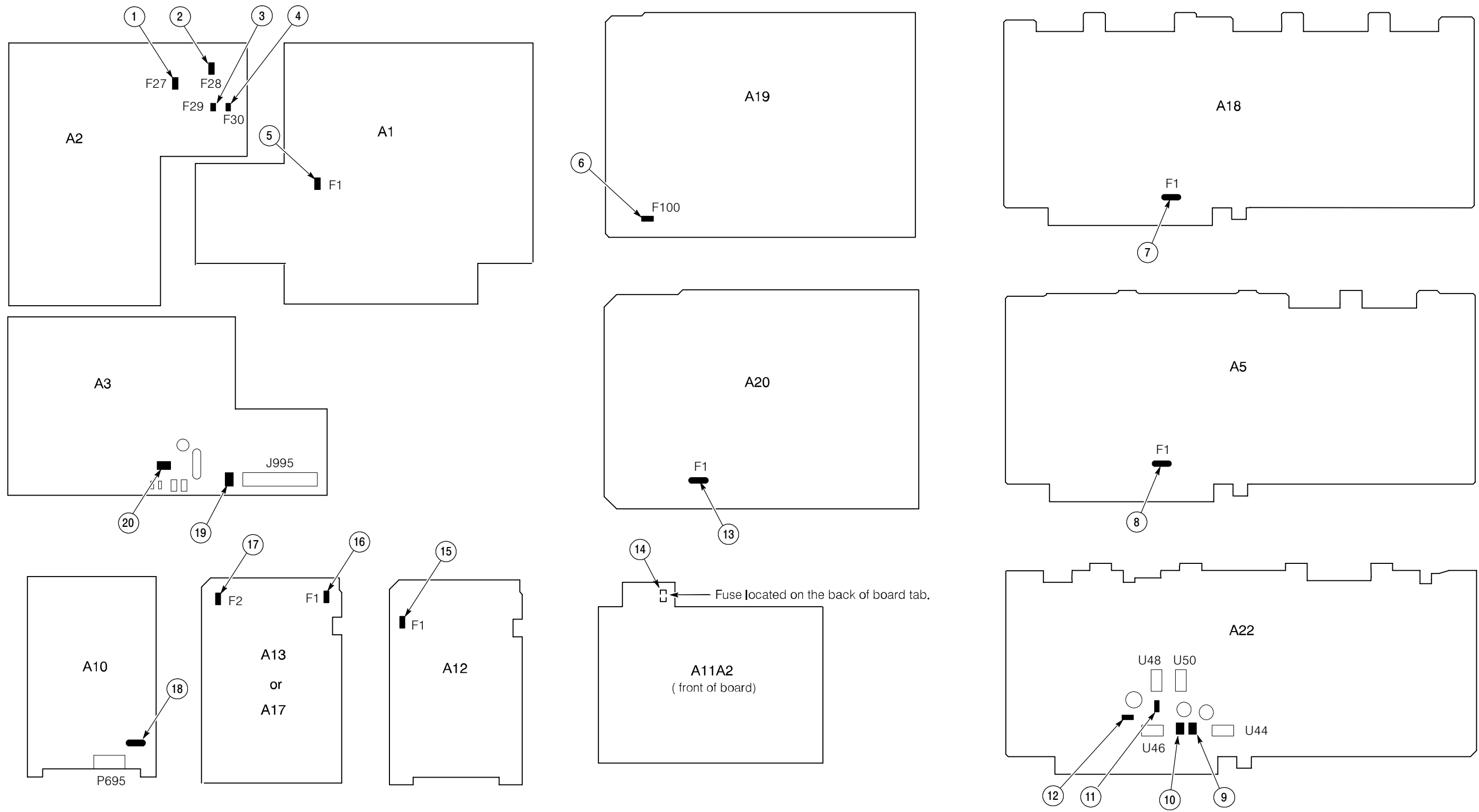

Figure 10-6: Circuit board fuse locations

