

Contents

Trouble Shooting	Page 2
Genuine Smith Meter Parts	Page 2
Special Tools and Fixtures	Page 2
Disassembly and Inspection	Page 3
Reassembly	Page 5
Service Records	Page 7

General

To insure the best performance of the PRIME Meter, the step-by-step procedures outlined in this manual should be followed. **Review the entire manual prior to disassembly or repair of the meter to fully understand the requirements.**

Trouble Shooting

No Pulses Generated

Preset Configuration

Check that the AccuLoad (electronic preset counter) is configured for contact input.

No Power

Check to see if there is power at the sensor. To do this, put the common lead of a voltmeter on the terminal to which the black wire of the sensor is connected. Measure the voltage on the red wire of the sensor. If it is not plus 12 or 24 Vdc \pm 10%, check the power supply.

Debris on Sensor Tip

If pulse failure occurred right after having the sensor out of the housing, look for debris at the tip of the sensor. The sensor must be completely seated in the housing. If it is just 0.020" away from seating, no pulses will be generated.

Broken Blade

Whenever the meter has been drained, there is the danger of hydraulic shock breaking a blade during the subsequent start-up. If there is flow through the meter and it is not making a light tapping sound (it may be necessary to place your ear on the meter to hear this sound), there is probably a broken blade and the rotor is not rotating. It will be necessary to drain the meter and remove the cover to inspect for a broken blade (see instructions below).

If there is no broken blade and the rotor turns freely, the lack of pulses is probably due to a faulty sensor. Be sure to replace with the proper sensor (Part No. 646592-4-01 is for single pulse output, 646596-4-01 is for dual pulse output).

Excessive Noise

The PRIME Meter makes very little noise when operating, especially at flow rates under 750 gpm. If the meter is making a noticeable rapid tapping sound, the cam following sections of the blades may be worn. It will be necessary to drain the meter and remove the cover to inspect for blade wear (see instructions below).

With the cover removed, rotate the rotor until one blade is horizontal. Try to move the blade in and out of the rotor. If there is a noticeable amount of free play (more than 0.020"), the blade is excessively worn and needs to be replaced (see instructions below).

Genuine Smith Meter Parts

The PRIME Meter is approved by several weights and measures authorities including NIST and CCA. In order to maintain these approvals, it is essential that all replacement parts are genuine Smith Meter Parts.

Special Tools and Fixtures

In addition to ordinary hand tools, the following tools and fixtures will be useful.

- An assortment of leaf-type **Feeler Gauges** soldered to a 15" extension rod

Part Number	Thickness
515252-1	0.0015"
515252-2	0.002"
515252-3	0.003"
515252-4	0.004"
515252-5	0.005"
515252-6	0.006"
515252-7	0.007"
515252-8	0.008"
515252-9	0.009"

- **Spider** (Part No. 554109-0-01) to center the shaft during assembly and clearance verification.
- **Ball end Allen Wrench** (3/16")
- **Platform** for the rotor assembly that is at least 1.5" thick and 10" in diameter or square with a 7.5" diameter hole through. The top surface should be smooth (Figure 1).
- **Internal retaining ring pliers.**
- Two 0.375-16 NC X 1.5" long **eyebolts** for cover removal.
- **Thread locking compound** (Part No. 643917-4-01) for the rotor cover screws.

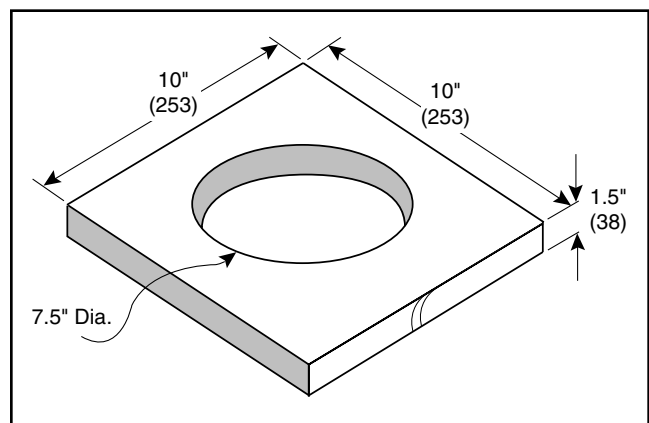

Figure 1 – Platform

Disassembly and Inspection

Caution: Disconnect power (12 Vdc) before working on the meter.

The following clearance table can be used to judge the degree of wear on various parts of the meter. It is a good idea to measure and record the clearances as the meter is disassemble.

Clearance Table

Measurement	Minimum	Maximum
Blade Slot	0.0025"	0.0055"
Blade End Play	0.0065"	0.0095"
Blade Tip to Housing	0.0055"	0.0045"
Blade Cam Followers Over Cam	0.001"	0.004"
Rotor to Block	0.0035"	0.0055"
Rotor Axial End Play (Rotor End Faces vs. Housing Bosses)	0.0015"	0.0065"

Remove Meter from Line

Drain the meter thoroughly prior to disconnecting the J-box wiring. The 1/4 NPT pipe plug on the meter cover is used to drain the meter. Depending upon the system piping, draining may take several minutes.

To lift the meter, use the eyebolt threaded into the boss on the housing (vertical installation) or the hole in the gusset (horizontal installation).

It is possible to examine the internals of the meter while it is installed in the line as mentioned in the Trouble Shooting section. This is done by removing the pulse sensor housing from the cover then removing the cover from the meter. However, service is not recommended without the complete removal of the meter from the line. This is because it is difficult to test spin the rotor.

WARNING!

Do not remove the sensor housing from the meter without first draining the meter. See warning tag on the sensor housing.

Remove Pulse Sensor and Sensor Housing

The pulse sensor is located in the sensor housing and can be replaced without the need of draining the meter and removing it from the line. This is accomplished by disconnecting all wiring connections (be sure and mark the wire locations) and disconnecting the union or unscrewing the conduit box from the sensor housing (Figure 2).



Figure 2

Remove the hex socket head pipe plug and retainer ring. The socket head pipe plug can be found under the warning tag located on the sensor housing (Figures 3 and 4).

Caution: The sensor is magnetized and can attract small pieces of metal at the tip. Be certain the sensor tip and sensor housing are absolutely clean prior to reinstalling the sensor. The slightest bit of debris can increase the distance between the sensor and the pulse target gear inside the meter and prevent the sensor from producing pulses.



Figure 3



Figure 4

Pull the sensor out by the wires (Figure 5).



Figure 5

WARNING!

Do not proceed with following steps unless meter has been blocked, depressurized and drained of product.

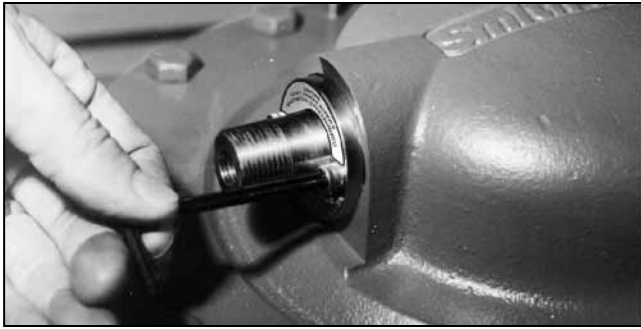

Figure 6



Figure 7

To remove the sensor housing, remove the two socket head screws. A ball end hexagonal wrench works best. Remove the o-ring (Figures 6 and 7).

Note: When reinstalling the sensor housing be sure to install the o-ring and the socket head pipe plug. Be sure that the housing is installed with the socket head pipe plug facing out.

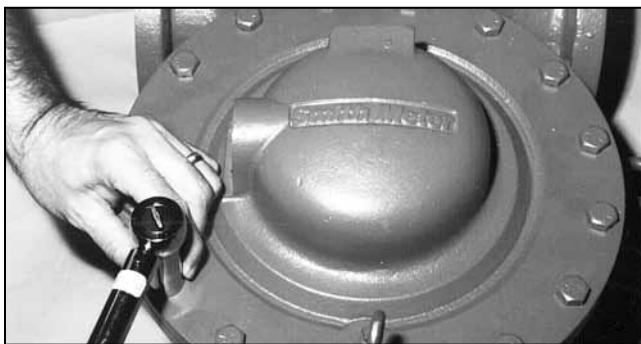

Figure 8 – Remove the Cover Bolts



Figure 9 – Remove Cover

Lift the cover and rotate slightly to separate it from the shaft (Figure 9). Lay the cover so that the inside faces upward. Remove the O-ring.

Loosen Shaft

Before the rotor can be removed, it is necessary to loosen the shaft from the socket in the meter body. This is done by loosening the shaft locking nut until it is flush with the end of the threaded rod. Give the nut a sharp blow with a soft hammer. This will free the locking cone at the other end of the shaft (Figure 10).

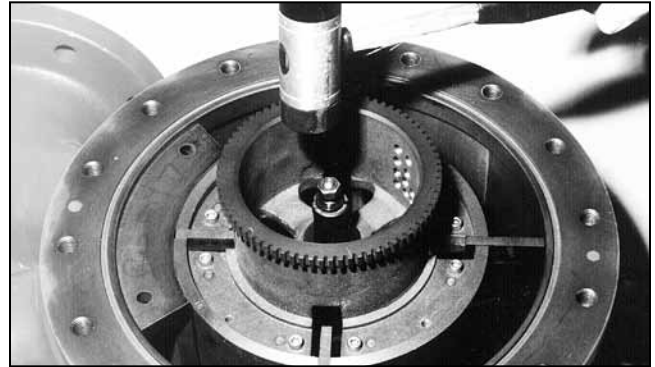

Figure 10 – Loosening Locking Cone

Remove Rotor

Carefully lift the rotor, shaft and blades from the meter body. If the shaft does not come free, it may be necessary to jar it loose with the momentum of the rotor. Once removed from the meter body, set the rotor assembly on the platform with a 7-1/2" diameter hole, rotor cover end up.

Disassemble Rotor

Remove the eight (8) socket head screws (Figure 11). Use four (4) of the screws as jack screws to evenly lift the rotor cover from the rotor. *Even though the dowel pins allow for proper orientation of the rotor cover, a chock mark across the rotor and rotor cover will speed the orientation during reassemble.*

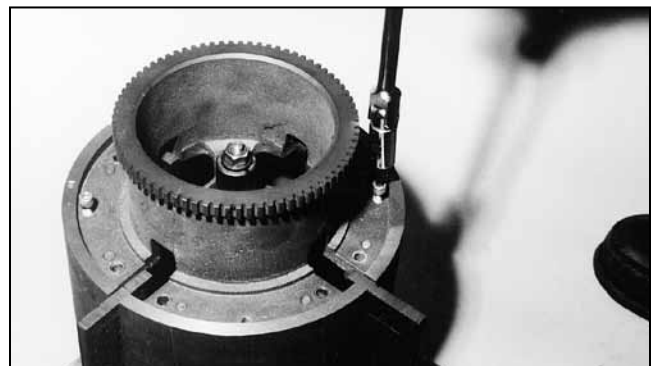

Figure 11 – Remove Rotor Cover

With the cover removed, use a three cornered file to file one notch in the outer blade and rotor slot (Figure 12). *On reassembly, it is important that the blades be positioned the same way in their original slot.* Remove the outer blade.

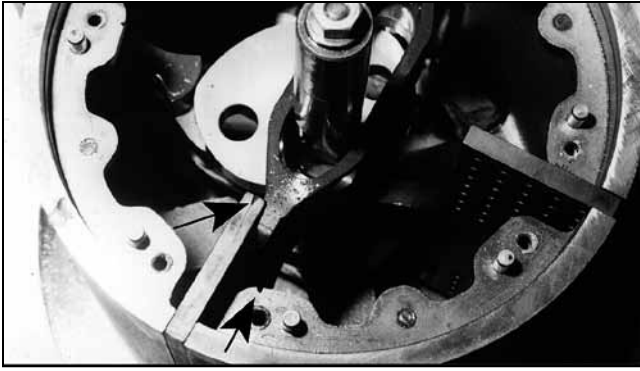

Figure 12 – Notch Out Blade and Rotor Slot

Lift the shaft and cam assemble out of the rotor. Notch the inner blade and rotor slot with two notches and remove.

Inspect the rotor for hairline cracks, particularly the slot bridges on the end opposite of the cover.

Pressing off the Cam

Press the shaft out of the cam using an arbor press. Note the step on the shaft and that the shaft can only be pressed in one direction (Figure 13). Before pressing off the cam, place a washer under the cam, so that the cam is not supported at the edges.



Figure 13 – Press Shaft Out of Cam

Inspection of Parts

Prior to reassembly, all parts should be inspected for excessive wear, corrosion or damage. Generally, all parts that affect meter clearances, e.g., blades, rotor, etc. that show measurable wear patterns should be replaced.

Reassembly

Shaft Assembly

Before pressing on the cam, place a washer under the cam, so that the cam is not supported at the edges. Place the key into the groove of the shaft and use an arbor press to press the shaft into the cam until it seats on the step (Figure 14).



Figure 14 – Press Shaft into Cam

Assemble Rotor

Place the rotor on the platform and install the inner blade, shaft assembly and the outer blade. If these are the original blades, be sure they are located properly in their slots according to the notches filed at disassembly (Figure 15).



Figure 15 – Locate Blades into their Respective Slots

It is essential that the contact surfaces between the rotor and rotor cover be absolutely clean. The slightest amount of debris trapped here will result in an increase in the distance between the rotor bearing ends and may not allow the rotor to rotate freely once inside the meter.

Rotate the rotor cover so that the dowel pin in the rotor match the hole pattern in the cover. Use thread locking compound (Part No. 643917-4-01) on rotor cover screws and evenly tighten to 48+/- 5 in-lbs torque (Figure 16).

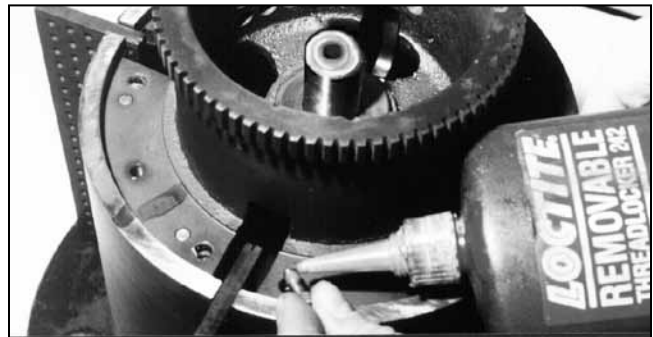

Figure 16 – Replace Rotor Cover

The shaft should rotate freely moving the blades in and out of the rotor.

Assemble Rotor to Body

Install the cone and shaft locking key into the shaft socket in the meter body (Figure 17).



Figure 17 – Cone and Shaft Locking Key in Shaft Socket

Rotate the shaft so that both blades are fully extended. Lift the rotor assembly and place it into the body so that the extended blades are opposite the block (Figure 18).

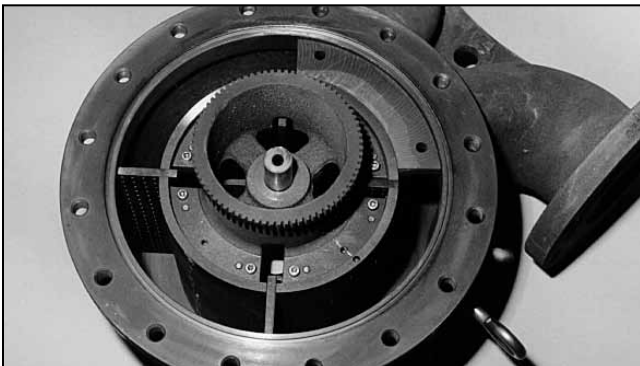

Figure 18 – Place Rotor into Body

The shaft should slide easily into the socket. Check that the shaft is fully engaged in the socket and will not rotate. It should be possible to rotate the rotor.

Thread the tie rod into the cone at least eight (8) turns. Place the washer and nut on the tie rod but do not tighten (Figure 19).

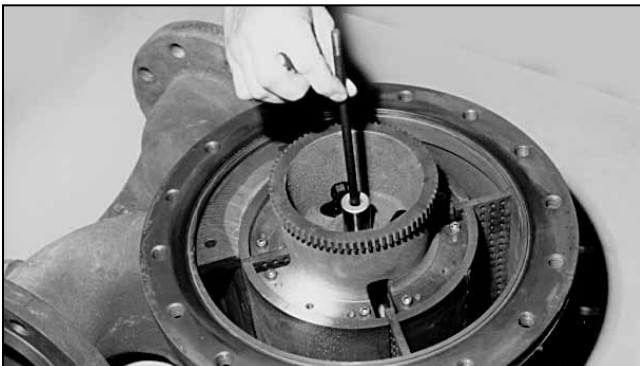

Figure 19 – Thread Tie Rod into the Cone

Blade Tip Clearances

Position the spider over the shaft and onto the body. The spider centers the shaft so that proper measurements can be taken.

If the blades are being replaced, it may be necessary to slightly file them to obtain the proper tip clearances.

Use feeler gages to check each blade tip when it is extended into the measuring chamber. It is necessary to push the blade against the small radius of the cam in order to properly measure this clearance (Figure 20). Use chalk to mark the areas of the blade tips that are too tight.



Figure 20 – Measure Blade Tip Clearance

Remove the rotor from the body and place on a smooth jawed vise, clamping down lightly on the opposite paddle to the one that will be filed. Coat the end of the paddle with bluing compound to aid in identifying the filing pattern. Use care not to remove too much stock (Figure 21).



Figure 21 – File Blade to Increase Blade Tip Clearance

Repeat as necessary until all blade tip clearances are between 0.0025" and 0.0045".

With the rotor in the body and the spider in place, check that the blade ends are no higher than the rotor. File down if necessary.

Tighten Shaft Locking Nut

With the rotor in the body and the spider in place, tighten the shaft locking nut on the end of the tie rod to 23-26 ft-lbs torque (Figure 22).

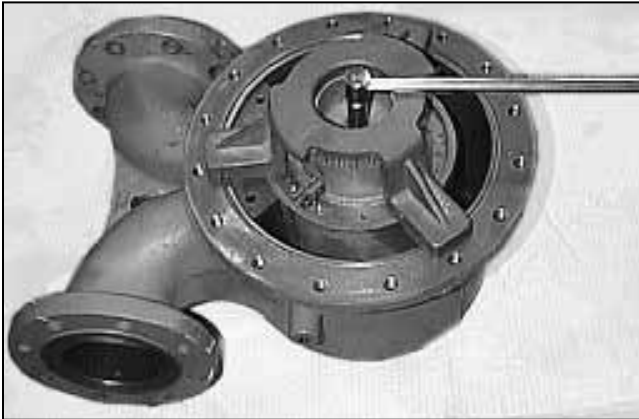

Figure 22 – Tighten Shaft Locking Nut

Install O-Ring and Cover

Use petroleum jelly or grease to lubricate the cover O-Ring and place in the groove on the body. Locate the cover so that the drain hole will be at the bottom of the meter when installed in the line. Evenly tighten the cover bolts using a criss-cross pattern to 260 ± 10 ft-lbs torque.

Install Sensor Housing, O-ring and Pulse Sensor

Use grease to lubricate the sensor housing O-Ring and place on the sensor housing. Install the sensor housing into the cover so that the notch in the threaded end of the sensor faces toward the drain in the cover. Use thread locking compound (Part Number 643917-4-01) on two socket head screws and tighten to 48 ± 5 in-lbs torque.

Install the drain plug into the cover.

Start-Up Procedures

Install Meter Into Line

When the meter is first installed in the line there is air inside the rotor. The air takes some time to work out. If the meter is subjected to hydraulic shock during this vulnerable time, the rotor can pinch down on the blades and cause blade breakage or cam shaft rotation. By following the specified start-up procedure, the likelihood of meter damage will be greatly reduced.

Note: Refer to PRIME 4 Installation/Operation Manual, Publication No. MN01038, for Start-Up Procedures.

Service Records

It is a good idea to keep records of all proving data on each meter. Significant shifts in accuracy between proving is normally an indicator that the meter requires service. Maintaining service records on the meter is also a good idea and may aid in trouble shooting future problems. The following Meter Clearance Record and Meter Proving Record forms are supplied for maintaining accurate service records.

Meter Clearance Record

Meter & Model _____ Serial Number _____

Item	Date	As Found	As Assembled
Blade Slot			
Blade End Play			
Blade Tip to Housing			
Blade Cam Followers Over Cam			
Rotor to Block			
Rotor Axial End Play			

Date	As Found	As Assembled

Date	As Found	As Assembled

Item	Date	As Found	As Assembled
Blade Slot			
Blade End Play			
Blade Tip to Housing			
Blade Cam Followers Over Cam			
Rotor to Block			
Rotor Axial End Play			

Date	As Found	As Assembled

Date	As Found	As Assembled

Meter Proving Record

Date: _____ Product _____

Flow Rate	Temp.	Pressure	Meter Factor

Date: _____ Product _____

Flow Rate	Temp.	Pressure	Meter Factor

Date: _____ Product _____

Flow Rate	Temp.	Pressure	Meter Factor

Date: _____ Product _____

Flow Rate	Temp.	Pressure	Meter Factor

Date: _____ Product _____

Flow Rate	Temp.	Pressure	Meter Factor

Date: _____ Product _____

Flow Rate	Temp.	Pressure	Meter Factor

Date: _____ Product _____

Flow Rate	Temp.	Pressure	Meter Factor

Date: _____ Product _____

Flow Rate	Temp.	Pressure	Meter Factor

Date: _____ Product _____

Flow Rate	Temp.	Pressure	Meter Factor

Revisions included in MN01041 Issue/Rev. 0.4 (7/11):
Page 7: Install O-Ring and Cover torque specification revised to 260 ± 10 ft-lbs torque.

The specifications contained herein are subject to change without notice and any user of said specifications should verify from the manufacturer that the specifications are currently in effect. Otherwise, the manufacturer assumes no responsibility for the use of specifications which may have been changed and are no longer in effect.

Contact information is subject to change. For the most current contact information, visit our website at www.fmctechnologies.com/measurementsolutions and click on the "Contact Us" link in the left-hand column.

Headquarters:

500 North Sam Houston Parkway West, Suite 100, Houston, TX 77067 USA, Phone: +1 (281) 260 2190, Fax: +1 (281) 260 2191

Measurement Products and Equipment:

Erie, PA USA +1 (814) 898 5000
Ellerbek, Germany +49 (4101) 3040
Barcelona, Spain +34 (93) 201 0989
Beijing, China +86 (10) 6500 2251
Buenos Aires, Argentina +54 (11) 4312 4736
Burnham, England +44 (1628) 603205

Dubai, United Arab Emirates +971 (4) 883 0303
Los Angeles, CA USA +1 (310) 328 1236
Melbourne, Australia +61 (3) 9807 2818
Moscow, Russia +7 (495) 5648705
Singapore, +65 6861 3011

Integrated Measurement Systems:

Corpus Christi, TX USA +1 (361) 289 3400
Kongsberg, Norway +47 (32) 286700
Dubai, United Arab Emirates +971 (4) 883 0303

Visit our website at www.fmctechnologies.com/measurementsolutions