



Service Manual

ZIRCONIA OXYGEN ANALYZER CONVERTER

TYPE: ZKM



Contents

| | |
|---|-----------|
| 1. GENERAL | 1 |
| 1.1 ZKM1 Internal constitution | 1 |
| 1.2 ZKM2 Internal constitution | 1 |
| 1.3 Description on display/setting section | 2 |
| 1.4 CPU board layout | 3 |
| 1.5 I/O board layout..... | 4 |
| 1.6 RS485 communication board layout..... | 4 |
| 2. ADJUSTMENT..... | 5 |
| 2.1 Necessary equipments for adjustment | 5 |
| 2.2 Adjustment flow..... | 5 |
| 3. CONNECTION AND CHECK | 6 |
| 3.1 Connection check..... | 6 |
| 3.2 Connection diagram for adjustment..... | 6 |
| 4. POWER ON AND VOLTAGE CHECK..... | 7 |
| 4.1 Power ON | 7 |
| 4.2 Check of the power supply voltage..... | 7 |
| 5. FACTORY-SET MODE..... | 8 |
| 5.1 Change settings from the initial screen to the factory-set screen (factory mode)..... | 8 |
| 5.2 Initial setting | 9 |
| 5.3 Measured menu..... | 9 |
| 5.4 Calibration menu | 9 |
| 5.5 Blowdown menu..... | 9 |
| 5.6 Maintenance menu..... | 9 |
| 5.7 Parameter menu | 10 |
| 5.8 Factory menu | 11 |
| 6. SETTING | 12 |
| 6.1 Analog output setting..... | 12 |
| 6.2 Analog output adjustment | 13 |
| 6.3 Blowdown setting screen..... | 14 |
| 6.4 Combustion efficiency display setting screen..... | 15 |
| 6.5 Surrounding temperature correction | 16 |
| 6.6 Thermocouple type setting screen | 17 |
| 6.7 Language type setting | 18 |
| 6.8 Communication setting..... | 19 |
| 6.9 Automatic calibration setting screen..... | 20 |
| 6.10 AD1 (O ₂ sensor input) adjustment..... | 21 |
| 6.11 AD2 (O ₂ sensor thermocouple input) adjustment | 22 |
| 6.12 AD3 (Thermocouple input for combustion control) adjustment..... | 23 |
| 6.13 Entry of the option password | 24 |
| 6.14 Serial number | 25 |
| 6.15 Digital output contact setting..... | 26 |
| 6.16 RBT contact setting | 27 |
| 6.17 Operation key setting..... | 28 |
| 6.18 Wire check start time setting..... | 29 |
| 6.19 Error check start time setting..... | 30 |

| | |
|---|-----------|
| 7. CALIBRATION BY A SIMULATION INPUT | 31 |
| 7.1 Manual SPAN calibration | 31 |
| 7.2 Manual ZERO calibration..... | 32 |
| 8. APPENDED FIGURES..... | 33 |
| 8.1 Table of reference thermal electromotive force of R-type thermocouple | 33 |
| 8.2 Table of reference thermal electromotive force of K-type thermocouple | 33 |
| 8.3 Table of theory output of zirconia oxygen detector | 34 |
| 8.4 Key operation flow diagram | 35 |

1. GENERAL

1.1 ZKM1 Internal constitution

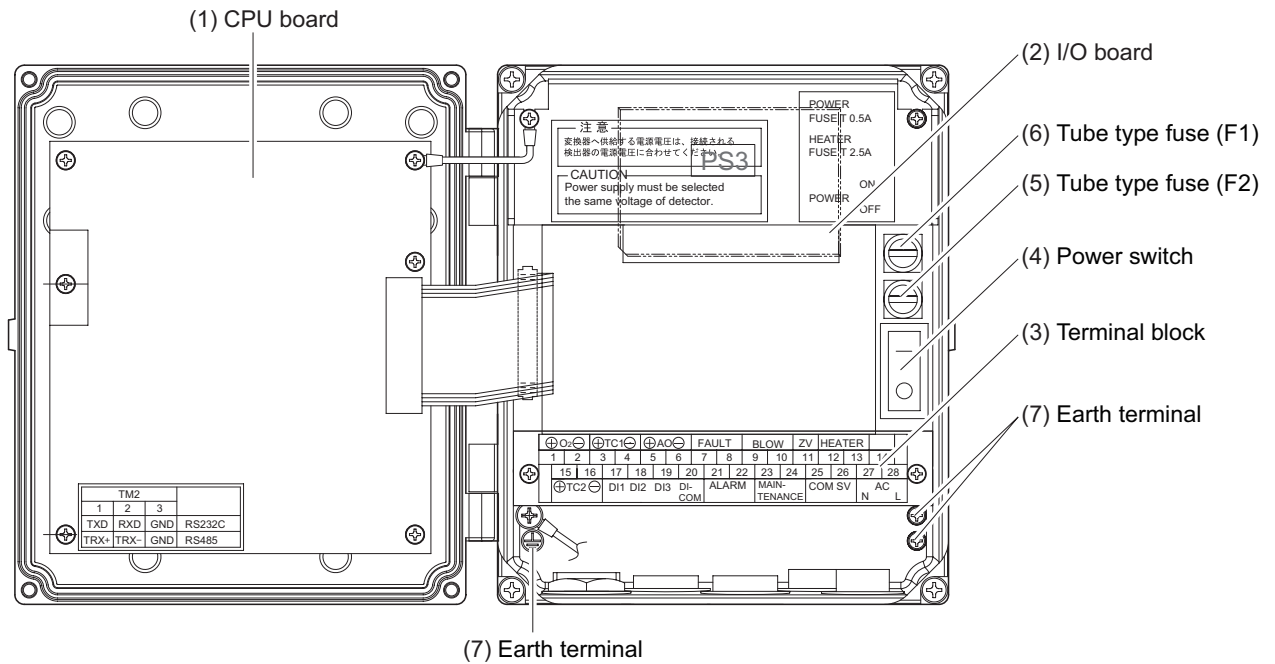

1.2 ZKM2 Internal constitution

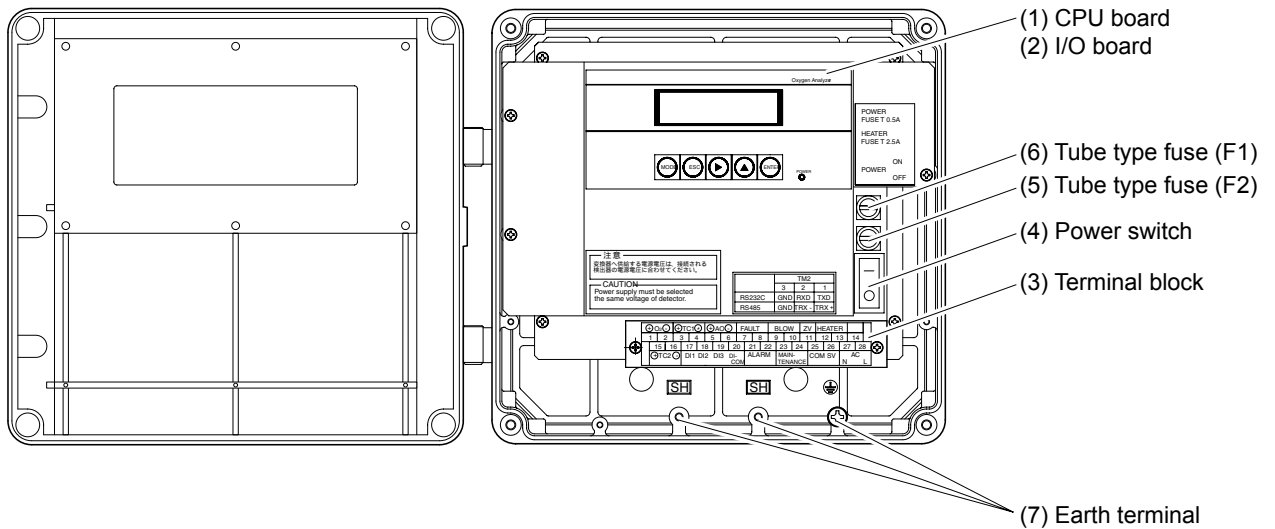

| Name | Explanation |
|-------------------------|--|
| (1) CPU board | The liquid crystal display and the memory circuit are installed. |
| (2) I/O board | The input/output circuit and the power circuit are installed. |
| (3) Terminal block | Terminal block for various input/output signals. |
| (4) Power switch | Turns ON/OFF this converter. (“-”: OFF, “o”: ON) |
| (5) Tube type fuse (F2) | Fuse for the heater. (250 V T 2.5 A) |
| (6) Tube type fuse (F1) | Fuse for the main unit (250 V T 0.5 A) |
| (7) Earth terminal | Used as frame gland (FG). |

1.3 Description on display/setting section

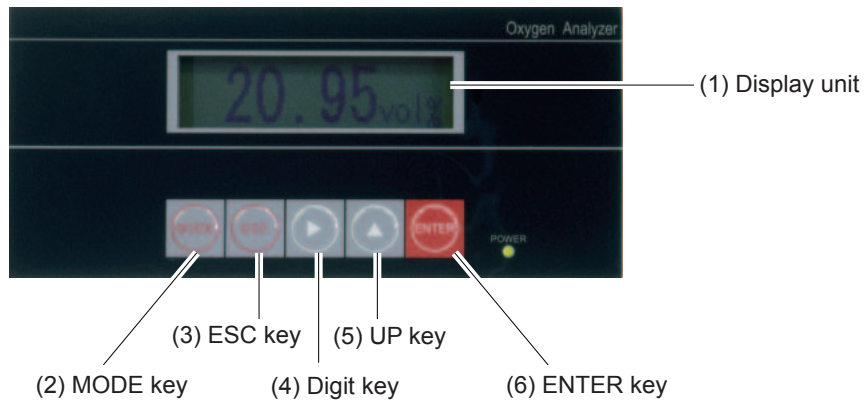

| Name | Explanation |
|------------------|--|
| (1) Display unit | Displays the concentration value and setting values. |
| (2) MODE key | Used to switch measurement display and mode display. |
| (3) ESC key | Used to return to the previous screen or exit the setting. |
| (4) Digit key | Used to change the setting values. |
| (5) Up key | |
| (6) ENTER key | Used to determine the setting values. |

1.4 CPU board layout

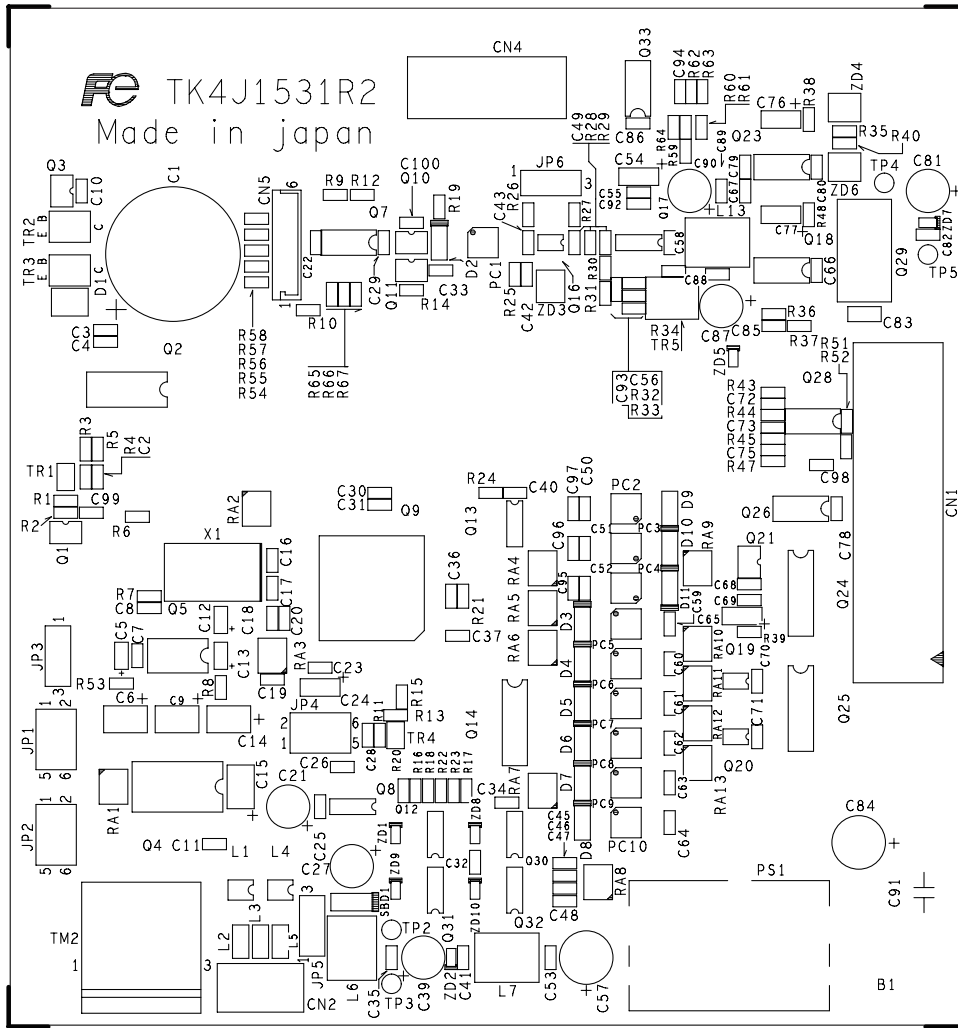

1.5 I/O board layout

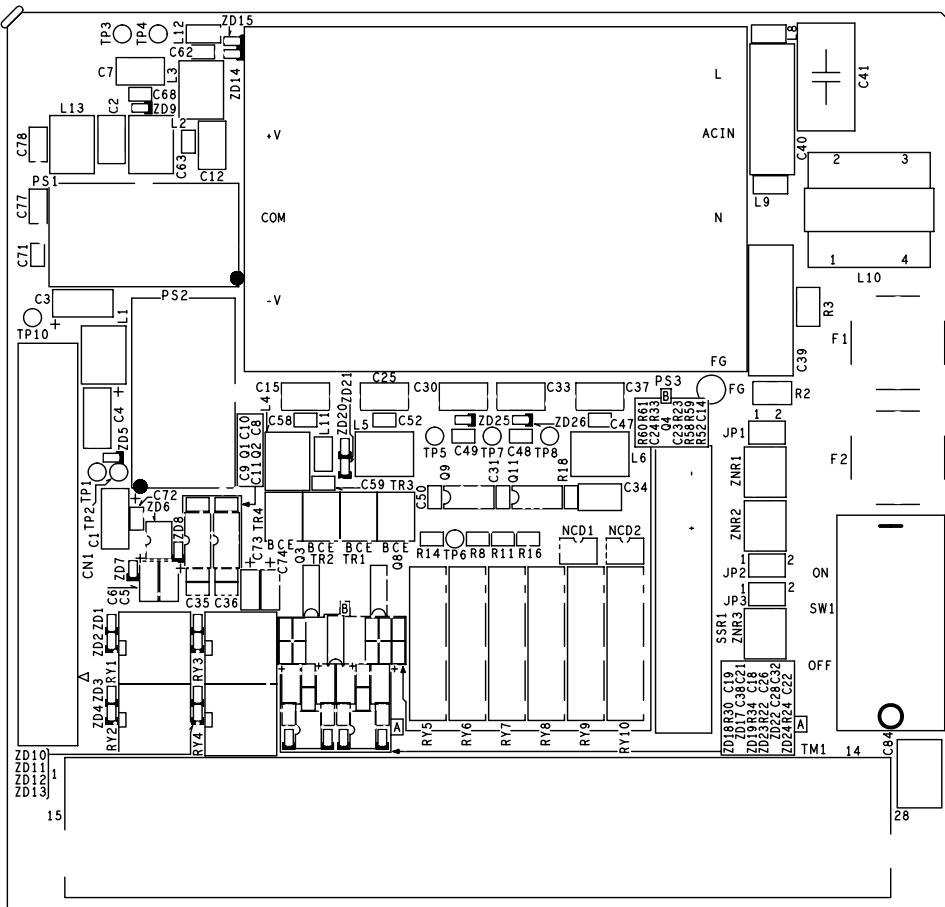

1.6 RS485 communication board layout

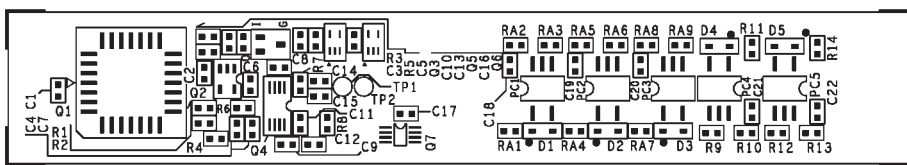

2. ADJUSTMENT

2.1 Necessary equipments for adjustment

| Name | Specification | No. of units |
|---------------------|---|--------------|
| Voltage generator | 0 to 200 mVDC Min. resolution 0.1 mV | 2 |
| Digital multi meter | Voltage measurement : 0 to 20 V DC Min. resolution 0.1 mV Current measurement : 0 to 100 mA DC Min. resolution 0.01 mA | 1 |

2.2 Adjustment flow

The ZKM adjustment flow is as follows.

- (1) Connection check
- (2) Power ON
- (3) Voltage check for each section
- (4) Factory-set mode
- (5) Individual adjustment
- (6) Calibration by a simulation input

3. CONNECTION AND CHECK

3.1 Connection check

Check if the connector is mounted appropriately.

3.2 Connection diagram for adjustment

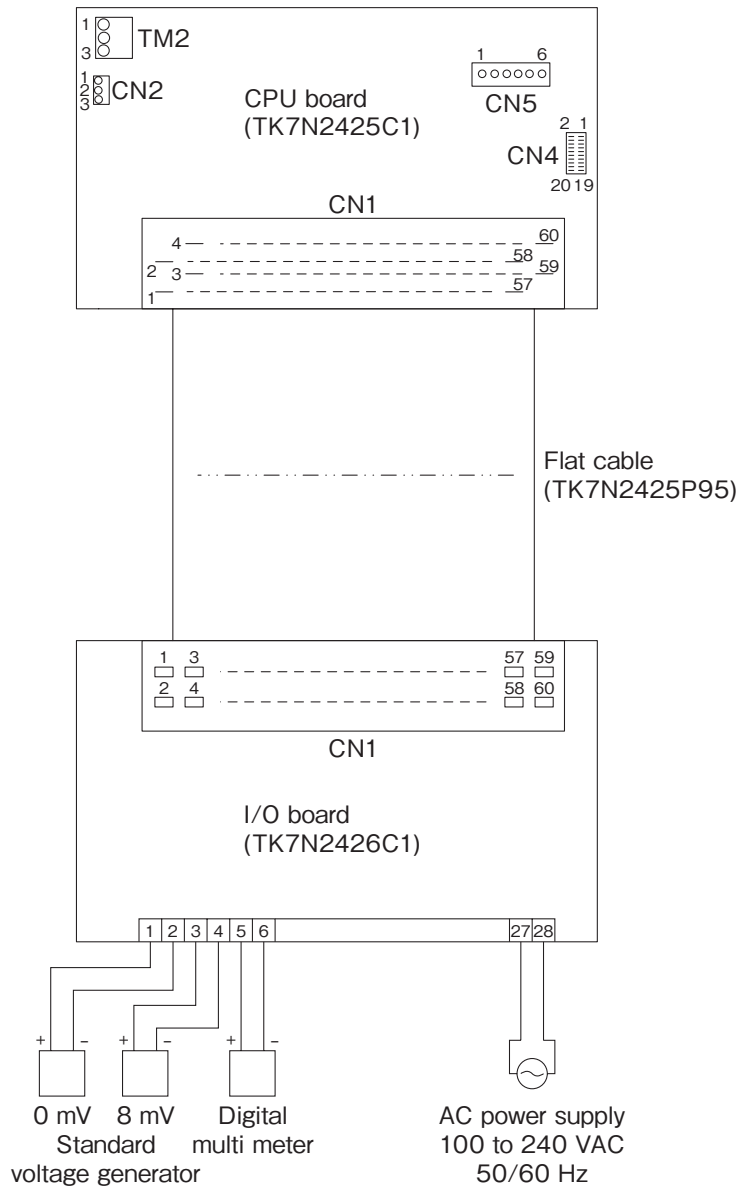

4. POWER ON AND VOLTAGE CHECK

4.1 Power ON

Open the front flap. Turn ON (-) the power switch.

| |
|------------------------------------|
| OXYGEN ANALYZER VER *.*.* YY/MM |
|------------------------------------|

The message shown left appears on the LCD screen.

| |
|--------------------------|
| WARM-UP HEATER 234 °C |
|--------------------------|

After about 6 seconds, the display is automatically switched to the Warm-up screen.

4.2 Check of the power supply voltage

Turn on the power supply of the converter and check the voltage of the printed circuit board according to the table below.

| Printed circuit board | Check terminal | Adjusting VR | Adjusting voltage |
|-------------------------|----------------------|--------------|-------------------|
| CPU board (TK7N2425) | Between TP2 and TP3 | - | +5.0±0.50V DC |
| | Between TP4 and TP5 | - | +5.0±0.30V DC |
| I/O board (TK7N2426) | Between TP1 and TP2 | - | +5.0±0.30V DC |
| | Between TP3 and TP4 | - | +15.0±0.75V DC |
| | Between TP3 and TP10 | - | -15.0±0.75V DC |
| | Between TP7 and TP5 | - | -12.0±1.00V DC |
| | Between TP7 and TP8 | - | +12.0±1.00V DC |

5. FACTORY-SET MODE

5.1 Change settings from the initial screen to the factory-set screen (factory mode).

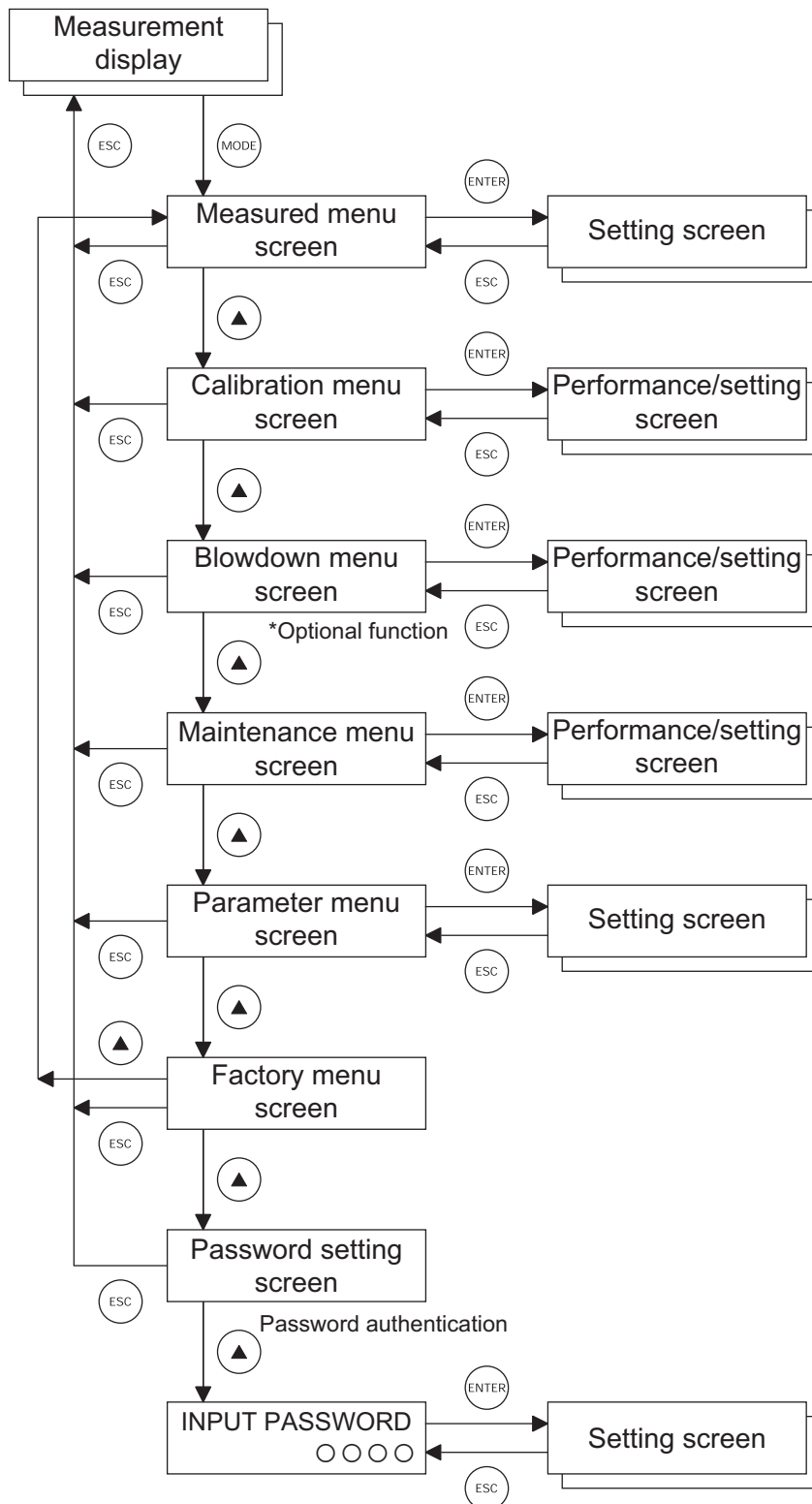

Enter "2404" by using the [increment] key and the [digit shift] key . Next, press the key once.

5.2 Initial setting

The table bellows show the factory-set values.

5.3 Measured menu

| Item | Setting item | LCD display | Default value | Remarks |
|------|-------------------------------------|----------------|---------------|---------|
| 1 | Display range | DISPLAY RANGE | RANGE1 | |
| 2 | Decimal point position | DECIMAL POINT | 00.00 | |
| 3 | Full scale | FULL SCALE | 25.00 vol% | |
| 4 | Calculation time of max./min. value | CALCULATE TIME | 024 h | |

5.4 Calibration menu

| Item | Setting item | LCD display | Default value | Remarks |
|------|--|------------------|--------------------|---------|
| 1 | Automatic calibration YES/NO | AUTO CALIBRATION | NO | |
| 2 | Date and time for starting automatic calibration | START DATE | 99/01/01 00:00 | |
| 3 | Automatic calibration cycle | AUTO CAL. CYCLE | 07d 00h | |
| 4 | Calibration gas | SPAN ZERO | 20.600% 02.000% | |
| 5 | Calibration wait time | CAL. WAIT TIME | 060s | |
| 6 | Calibration range operation | ABOUT CAL. RANGE | BOTH | |

5.5 Blowdown menu

| Item | Setting item | LCD display | Default value | Remarks |
|------|---|-----------------|----------------|---------|
| 1 | Automatic blowdown YES/NO | BLOW DOWN | NO | |
| 2 | Date and time for starting automatic blowdown | START DATE | 99/01/01 00:00 | |
| 3 | Automatic blowdown cycle | AUTO BLOW CYCLE | 24h 00m | |
| 4 | Blowdown time | BLOW DOWN TIME | 030 s | |

5.6 Maintenance menu

| Item | Setting item | LCD display | Default value | Remarks |
|------|---------------------------------|----------------|---------------|---------|
| 1 | Sensor check for calibration | SENSOR CHECK | NO | |
| 2 | Sensor recovery for calibration | SENSOR RECOVER | NO | |

5.7 Parameter menu

| Item | Setting item | LCD display | Default value | Remarks |
|------|--------------------------------------|------------------------------|----------------|---------|
| 1 | Current date and time | DATE SET | 00/01/01 00:00 | |
| 2 | Contact input | DI 1 | NONE | |
| 3 | Contact input | DI 2 | NONE | |
| 4 | Contact input | DI 3 | NONE | |
| 5 | Alarm contact output | DO ALARM | ALARM NONE | |
| 6 | High limit of oxygen concentration | OXYGEN ALARM HIGH ALARM | 50.000 vol% | |
| 7 | Low limit of oxygen concentration | OXYGEN ALARM LOW ALARM | 00.020 vol% | |
| 8 | H-High limit of oxygen concentration | OXYGEN ALARM H-HIGH ALARM | 55.000 vol% | |
| 9 | L-Low limit of oxygen concentration | OXYGEN ALARM L-LOW ALARM | 00.010 vol% | |
| 10 | Hysteresis | OXYGEN ALARM HYSTERESIS | 10 % | |
| 11 | Heater temperature error | HEATER ERROR | 010 °C 01 % | |
| 12 | Output hold YES/NO | OUTPUT HOLD | NO | |
| 13 | Hold value | OUTPUT SELECT | 0 % | |
| 14 | Hold setting value | HOLD VALUE | 000 % | |
| 15 | Measurement wait time | MEAS. WAIT TIME | 010 s | |
| 16 | Key lock | KEY LOCK | NO | |
| 17 | Automatic backlight OFF time | BACKLIGHT TIME | 10 m | |
| 18 | Station number | STATION NO | 01 | |

5.8 Factory menu

| Item | Setting item | LCD display | Default value | Remarks |
|------|-------------------------------------|------------------|-----------------|----------|
| 1 | Analog output | ANALOG OUT TYPE | 4 to 20 mA | |
| 2 | Blowdown | BLOW DOWN | NO | <Note 1> |
| 3 | Combustion efficiency display | COMBUSTIBLE TIME | NO | <Note 1> |
| 4 | Warm-up operation monitoring time | WARM-UP TIME | 45 m | |
| 5 | Movement average time | AVERAGING TIME | 02 s | |
| 6 | Heater temperature control | TEMP. CONTROL | 800 °C | |
| 7 | Heater low temperature control | LOW TEMP. | 70 °C | |
| 8 | Heater low temperature control time | LOW TEMP. TIME | 30 m | |
| 9 | Heater temperature error | HEATER TEMP.ERR. | 70 °C 1% | |
| 10 | Thermocouple type | THERMO COUPLE | R-TYPE | |
| 11 | Language type | LANGUAGE | ENGLISH | |
| 12 | Password | PASSWORD | 2404 | |
| 13 | Manual sensor recovery type | RECOVER TYPE | AC | |
| 14 | AC recovery | Ω TIME | 100 Ω 005 m | |
| 15 | High temperature recovery | HI-TEMP. TIME | 900 °C 010 m | |
| 16 | PID parameter | P I D | 020 03000 00600 | |
| 17 | Default parameter | DEFAULT PARA SET | YES | |
| 18 | Communication | COMMUNICATION | RS232C | <Note 1> |
| 19 | Automatic calibration | AUTO CAL. SET | NO | <Note 1> |
| 20 | Error check start time | ERR CHECK TIME | 420 s | |
| 21 | Operation key | OPERATION KEY | 5 KEY | <Note 1> |
| 22 | Error output | ERROR OUT | YES | |
| 23 | RBT contact | RBT CONTACT | NO | <Note 1> |
| 24 | Surrounding temperature | SURROUNDING TEMP | ZERO COUNT | |
| 25 | Offset at 10°C | OFFSET 10°C | 378 | |
| 26 | Output contact | DIGITAL OUT SET | NO | |
| 27 | Wire check start time | WIRE CHECK TIME | 05 m | |
| 28 | Option password | OPTION PASS | - | |
| 29 | Main unit serial number | ID INFO | - | |



Note 1: Entry of the option password is required to change settings.

6. SETTING

6.1 Analog output setting

Purpose: To set an analog output type (4 to 20 mA/0 to 1 V).

Procedure:

- 1) Enter the <FACTORY MENU/ANALOG OUT TYPE> screen.
- 2) Select the <ANALOG OUT TYPE> screen by the  key.
- 3) Press the  key to enter the <ANALOG OUT TYPE> screen.

Current setting is highlighted.

- 4) Select an analog output type by the  key.
Selected type is highlighted.

- 5) Press the  key to determine the setting.
The set type is displayed.

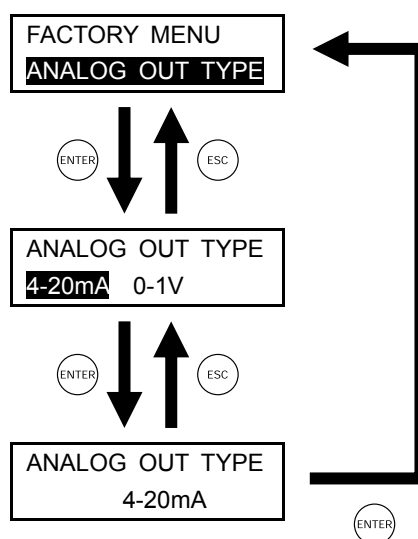

* Always switch the output jumper pin (JP6) on the CPU printed circuit board after selection of the output.

| 5th digit of code symbol | Output type | JP6 |
|--------------------------|-------------|--------|
| B | 4 to 20 mA | 1 to 2 |
| E | 0 to 1 V | 2 to 3 |

6.2 Analog output adjustment

Purpose: To adjust "0% (4 mA/0V)" and "100% (20 mA/1V)" of an analog output.

- * When "4-20 mA" is selected, adjust an analog output by connecting ammeter to the "5 (+AO)" and "6 (-AO)" of an external terminals.
When "0-1V" is selected, adjust an analog output by connecting the voltmeter to the "5 (+AO)" and "6 (-AO)" of an external terminals.
- * Same adjustment for the factory mode. (both of them are available)

Procedure:

- 1) Enter the <PARAMETER MENU/A-OUT ADJUST> screen.
- 2) Select the <A-OUT ADJUST> screen by the \blacktriangle key.
- 3) Press the ENTER key to enter the <A-OUT ADJUST> screen.
- 4) Select the analog output adjustment screen by the \blacktriangle key.
- 5) Press the ENTER key to enter the analog output adjustment screen.
- 6) Adjust an analog output by the \blacktriangle or \blacktriangleright key.
"DOWN" or "UP" is selectable by pressing the \blacktriangleright key.
Change an analog output by the \blacktriangle key while checking the analog output by the digital multi meter or the like.
- 7) Press the ENTER key to determine the setting.

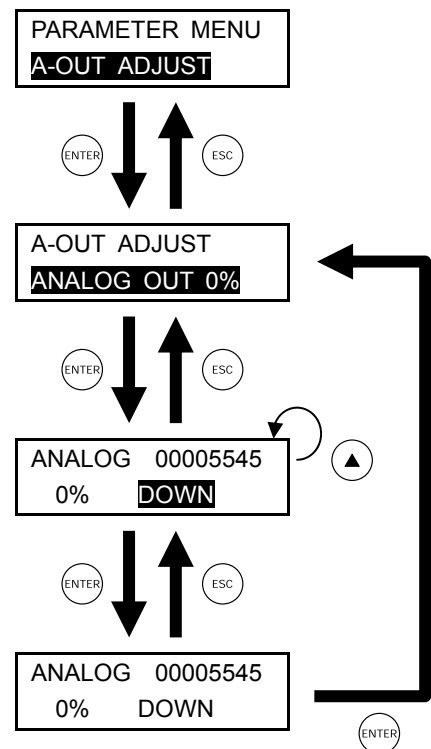

When selecting the analog output adjustment screen ;

If adjust "0% (4 mA/0V)" of the analog output, select "ANALOG OUT 0%".

If adjust "100% (20 mA/1V)" of the analog output, select "ANALOG OUT 100%".

| Output type | Output | | Count value | |
|-------------|---------|----------|-------------|-------|
| | 0 % | 100 % | 0 % | 100 % |
| 4 to 20 mA | 4.00 mA | 20.00 mA | 5550 | 28070 |
| 0 to 1 V | 0.00 V | 1.00 V | 9600 | 29600 |

6.3 Blowdown setting screen

Purpose: To set the blowdown function YES/NO (Enabled /Disabled).

If “NO” is set, items for blowdown are not displayed in the menu.

The 9th digit of code symbol is <enabled when 2, 4, 6, or 7 is selected>

Procedure:

1) Enter the <FACTORY MENU/BLOW DOWN> screen.

2) Select the <BLOW DOWN> screen by the  key.

3) Press the  key to enter the <BLOW DOWN> screen.

Current setting is highlighted.

4) Select BLOWDOWN YES/NO by the  key.

Selected one is highlighted.

5) Press the  key to determine the setting.

Your setting is displayed.

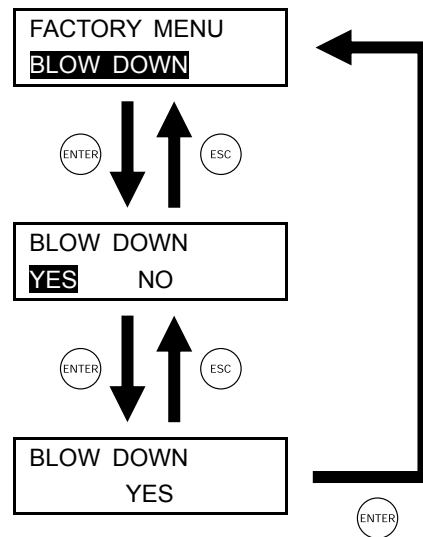

Setting: Make a setting as the following table according to the 9th digit of the code symbol.

| 9th digit of code symbol | Blowdown function | Setting value |
|--------------------------|-------------------|---------------|
| Y, 1, 3, 5 | Disabled | NO |
| 2, 4, 6, 7 | Enabled | YES |

Entry of the option password is required to change this parameter.

6.4 Combustion efficiency display setting screen

Purpose: To set combustion efficiency YES/NO (Display/Not display).

When "NO" is set, the combustion efficiency screen is not displayed.

The 9th digit of code symbol is <enabled when 1, 4, 5, or 7 is selected>.

Procedure:

1) Enter the <FACTORY MENU/COMBUSTIBLE EFF.> screen.

2) Select the <COMBUSTIBLE EFF.> screen by the  key.

3) Press the  key to enter the <COMBUSTIBLE EFF.> screen.

Current setting is highlighted.

4) Select COMBUSTIBLE EFF. YES/NO by the  key.

Selected one is highlighted.

5) Press the  key to determine the setting.

Your setting is displayed.

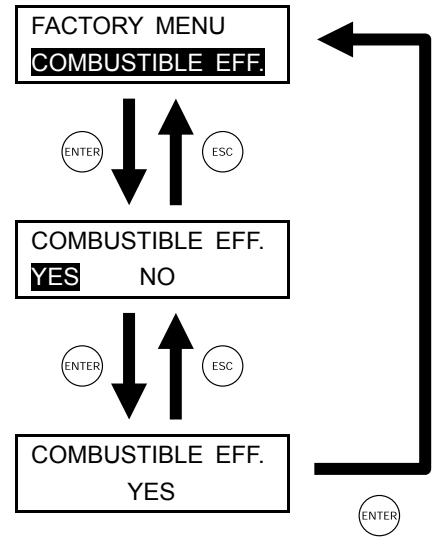

Setting: Make a setting as following table according to the 9th digit of code symbol.







| 9th digit of code symbol | Screen display | Setting value |
|--------------------------|----------------|---------------|
| Y, 2, 3, 6 | Not displayed | NO |
| 1, 4, 5, 7 | Displayed | YES |

Entry of the option password is required to change this parameter.

6.5 Surrounding temperature correction

Purpose: To adjust an analog input 2 (O₂ sensor thermocouple input).

Procedure:

- 1) Enter the <FACTORY MENU/SURROUNDING TEMP> screen.
- 2) Select the <SURROUNDING TEMP> screen by the  key.
- 3) Press the  key to enter the <SURROUNDING TEMP> screen.
- 4) Select "ZERO COUNT" by the  key.
- 5) Set the surrounding temperature near the converter by the  or  key.
Input a count value (1, 2500, or 5000).
1 : 34°C 2500 : 25°C 5000 : 20°C
- 6) Press the  key to determine the setting.

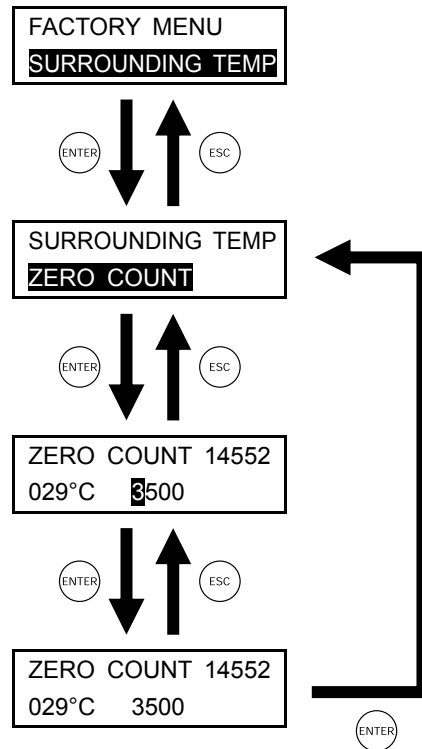

6.6 Thermocouple type setting screen

Purpose: To set a thermocouple type for temperature measurement of the detector.

The 4th digit of code symbol <K: when K thermocouple is specified>

Procedure:

Select the <THERMO COUPLE> screen by the  key.

Press the  key to enter the <THERMO COUPLE> screen.

Current setting is highlighted.

Select a THERMO COUPLE K-TYPE/R-TYPE by the  key.

Selected one is highlighted.

Press the  key to determine the setting.

Your setting is displayed.

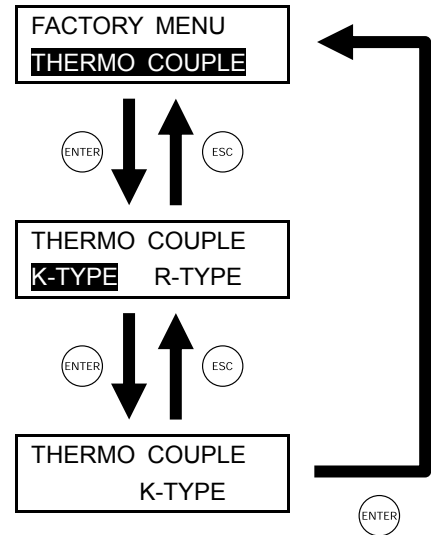



* R-type thermocouple : I/O board TK7N2426C1 R-thermo
K-type thermocouple : I/O board TK7N2426C2 K-thermo
Circuit constants are different.

6.7 Language type setting

Purpose: To set the characters to be displayed according to the 10th digit of code symbol.

Procedure:

- 1) Enter the <FACTORY MENU/LANGUAGE> screen.
- 2) Select the <LANGUAGE> screen by the  key.
- 3) Press the  key to enter the <LANGUAGE> screen.

Current setting is highlighted.

- 4) Select a language type by the  key.

Selected language is highlighted.

- 5) Press the  key to determine the setting.

Your setting is displayed.

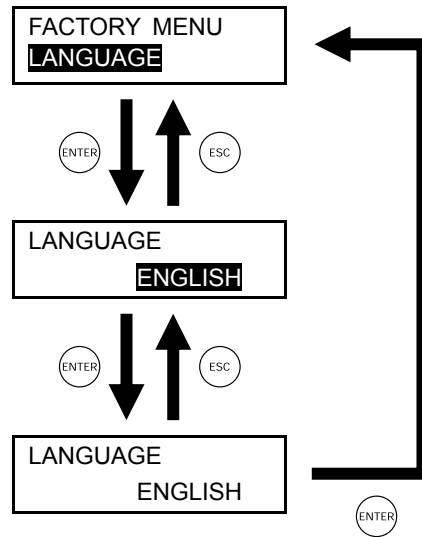

Setting: Set one language from the following table according to the 10 the digit of code symbol.

| 10th digit of code symbol | Display language |
|---------------------------|------------------|
| J | Japanese |
| E | English |
| C | Chinese |

6.8 Communication setting

Purpose: To set a communication type.

The 6th digit of code symbol

Procedure:

1) Enter the <FACTORY MENU/COMMUNICATION> screen.

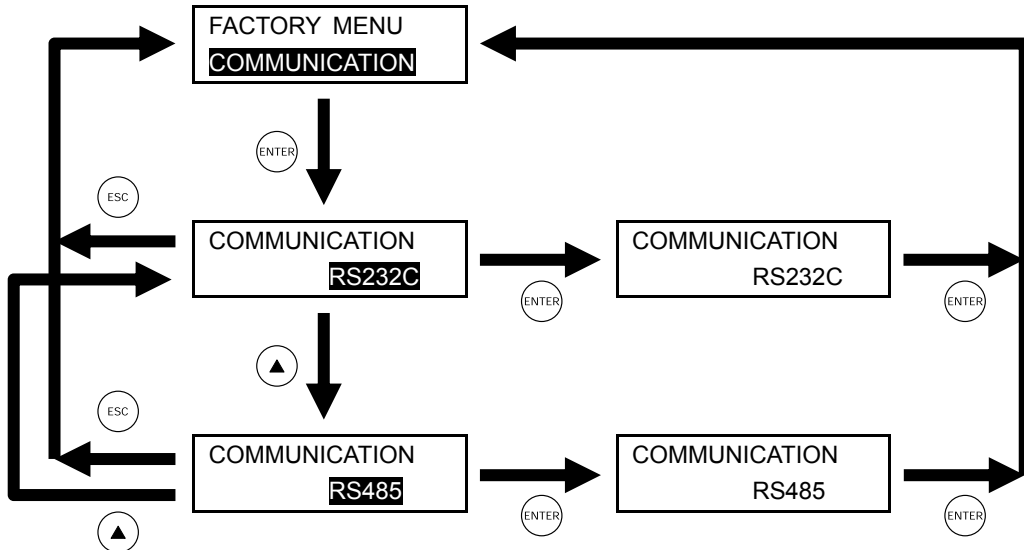

2) Select the <COMMUNICATION> screen by the \blacktriangle key.

3) Press the ENTER key to enter the <COMMUNICATION> screen.

4) Select a communication type by the \blacktriangle key.

5) Press the ENTER key to determine the communication type.

6) Press the ENTER key to determine the setting.

* Always switch the output jumper pin (JP1, JP2) on the CPU printed circuit board after selection of a communication type.

| 6th digit of code symbol | Communication type | JP1 | JP2 | JP5 | JP6 |
|--------------------------|--------------------|------------|------------|-----|-----|
| 1 | RS232C | 3-5 4-6 | 3-5 4-6 | 2-3 | - |
| 2 | RS485 | 1-3 2-4 | 1-3 2-4 | 1-2 | - |

Entry of the option password is required to change this parameter.

6.9 Automatic calibration setting screen

Purpose: To set the automatic calibration function YES/NO (Enabled/Disabled).

When "NO" is selected, items related to the automatic calibration is not displayed in the menu.

The 9th digit of code symbol is <available when 3, 5, 6, or 7 is selected>

Procedure:

1) Enter the <FACTORY MENU/AUTO CAL. SET> screen.

2) Select the <AUTO CAL. SET> screen by the  key.

3) Press the  key to enter the <AUTO CAL. SET> screen.

Current setting is highlighted.

4) Select AUTO CAL. SET YES/NO by the  key.

Selected one is highlighted.

5) Press the  key to determine the setting.

Your setting is displayed.

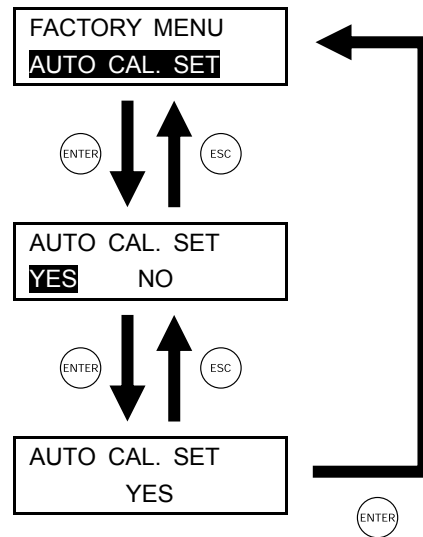

Setting: Make a setting as the following table according to the 9th digit of code symbol.





| 9th digit of code symbol | Auto calibration function | Setting value |
|--------------------------|---------------------------|---------------|
| Y, 1, 2, 4 | Disabled | NO |
| 3, 5, 6, 7 | Enabled | YES |

Entry of the option password is required to change this parameter.

6.10 AD1 (O₂ sensor input) adjustment

Purpose: To adjust an analog input 1 (O₂ sensor input).

Procedure:

- 1) Enter the <FACTORY MENU/ADJUDT> screen.
- 2) Select the <ADJUST> screen by the  key.
- 3) Press the  key to enter the <ADJUST> screen.
- 4) Select the <AD1 LOW VALUE> screen by the  key.
- 5) Press the  key to enter the <AD1 LOW VALUE> screen.
- 6) Apply 0.000 mV to "1 (+O₂)" and "2 (-O₂)" of the external terminals. *
- 7) Press the  key to determine the setting.

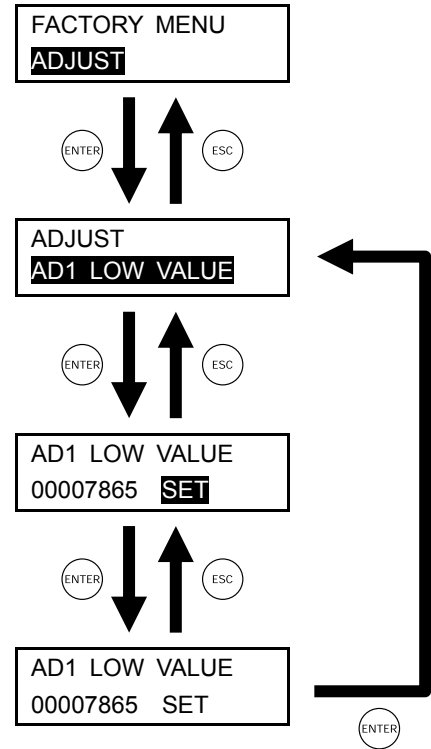

- * When selecting the O₂ sensor input adjustment screen, select "AD1 LOW VALUE" first, and then apply 0.000 mV to "1 (+O₂)" and "2 (-O₂)" of the external terminals to perform adjustment. Next, select "AD1 HIGH VALUE" and apply 100.000 mV to "1 (+O₂)" and "2 (-O₂)" of the external terminals to perform adjustment. Make sure to perform the both adjustments.

| Input | Count value |
|---------------|-------------|
| Low : 0 mV | 7800 |
| High : 100 mV | 17200 |

6.11 AD2 (O₂ sensor thermocouple input) adjustment

Purpose: To adjust an analog input 2 (O₂ sensor thermocouple input).

Procedure:

- 1) Enter the <FACTORY MENU/ADJUST> screen.
- 2) Select the <ADJUST> screen by the \blacktriangle key.
- 3) Press the $\text{\textcircled{ENTER}}$ key to enter the <ADJUST> screen.
- 4) Select the <AD2 LOW VALUE> screen by the \blacktriangle key.
- 5) Press the $\text{\textcircled{ENTER}}$ key to enter the <AD2 LOW VALUE>screen.
- 6) Apply 0,000 mV to “3 (+TC1)” and “4 (-TC1)” of external terminals. *
- 7) Press the $\text{\textcircled{ENTER}}$ key to determine the setting.

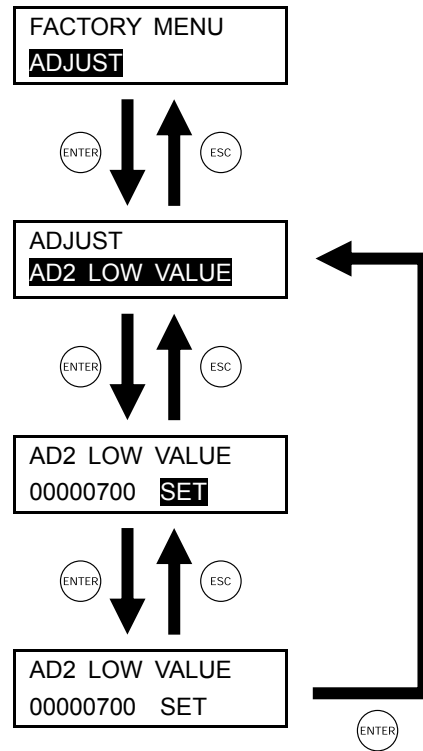

- * When selecting the O₂ sensor thermocouple input adjustment screen, select “AD2 LOW VALUE” first, and then apply 0.000 mV to “3 (+TC1)” and “4 (-TC1)” of the external terminals to perform adjustment. Next, select “AD2 HIGH VALUE” and apply 9.000 mV to “3 (+TC1)” and “4 (-TC2)” of the external terminals to perform adjustment. Make sure to perform the both adjustments.

R-type thermocouple

| Input | Count value |
|-------------|-------------|
| Low : 0 mV | 1000 |
| High : 9 mV | 29600 |

K-type thermocouple

| Input | Count value |
|--------------|-------------|
| Low : 0 mV | 700 |
| High : 40 mV | 32700 |

6.12 AD3 (Thermocouple input for combustion control) adjustment

Purpose: To adjust an analog input 3 (thermocouple input for combustion control).

Procedure:

- 1) Enter the <FACTORY MENU/ADJUST> screen.
- 2) Select the <ADJUST> screen by the \blacktriangle key.
- 3) Press the $\text{\textcircled{ENTER}}$ key to enter the <ADJUST> screen.
- 4) Select the <AD3 LOW VALUE> screen by the \blacktriangle key.
- 5) Press the $\text{\textcircled{ENTER}}$ key to enter the <AD3 LOW VALUE> screen.
- 6) Apply 0.000 mV to "15 (+TC2)" and "16 (-TC2)" of external terminals. *
- 7) Press the $\text{\textcircled{ENTER}}$ key to determine the setting.

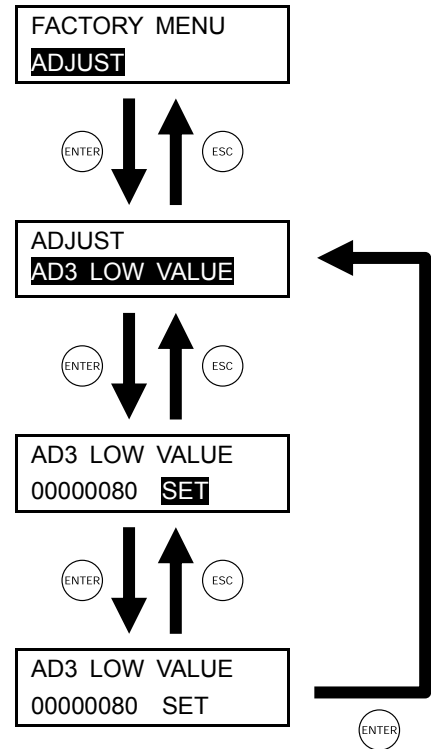

* When selecting the thermocouple input for combustion control adjustment screen, select "AD3 LOW VALUE" first, and then apply 0.000 mV to "15 (+TC2)" and "16 (-TC2)" of the external terminals to perform adjustment.

Next, select "AD3 HIGH VALUE" and apply 9.000 mV to "15 (+TC2)" and "16 (-TC2)" of the external terminals to perform adjustment.

Make sure to perform the both adjustments.

| Input | Count value |
|-------------|-------------|
| Low : 0 mV | 1200 |
| High : 9 mV | 15800 |

6.13 Entry of the option password

Purpose: To enter the password for changing settings of option items.

* Password is managed by each unit and it is not public.

Procedure:

1) Enter the <FACTORY MENU/OPTION PASS> screen.

2) Press the  key to enter the <PASSWORD> screen.

3) Press the  and  keys to enter the password.

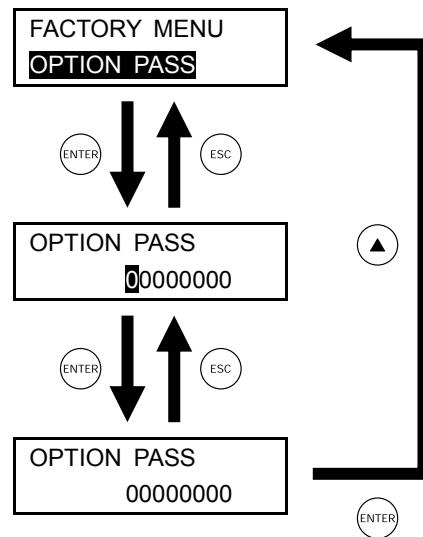

4) Press the  key to determine the setting.



6.14 Serial number

Purpose: To display the serial number of main unit.

Procedure:

- 1) Enter the <FACTORY MENU/ID INFO> screen.
- 2) Press the  key to enter the <ID INFO> screen.
- 3) Press the  key to go back to the <FACTORY MENU/ID INFO> screen.

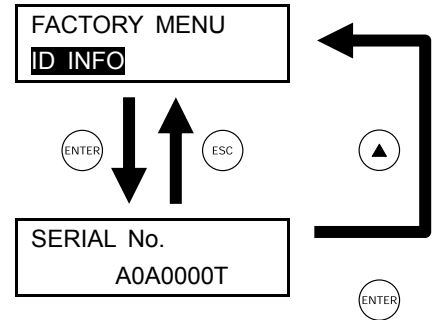

* You can not change.

6.15 Digital output contact setting

Purpose: To set a digital output contact for COSA, DELTA, and RBT. [Free terminal allocation]

The 4th digit of code symbol <When R or K is specified: for RTB>



The 12th digit of code symbol <When 3, 4, 6, or 7 is specified: for COSA/DELTA>

Differences from the standard specification

| Function | Standard spec. | COSA/DELTA spec. |
|---------------------------|----------------|-----------------------|
| Maintenance(MAINTEN) | DO6 (fixed) | DO1 to DO6 (settable) |
| Calibration (MAINTEN) | DO6 (fixed) | DO1 to DO6 (settable) |
| Blowdown (BLOW) | DO5 (fixed) | DO1 to DO6 (settable) |
| Span valve (SV) | DO4 (fixed) | DO1 to DO6 (settable) |
| Zero valve (ZV) | DO3 (fixed) | DO1 to DO6 (settable) |
| H alarm (ALARM) | DO2 (fixed) | DO1 to DO6 (settable) |
| L alarm (ALARM) | DO2 (fixed) | DO1 to DO6 (settable) |
| H-High alarm (ALARM) | DO2 (fixed) | DO1 to DO6 (settable) |
| L-Low alarm (ALARM) | DO2 (fixed) | DO1 to DO6 (settable) |
| Equipment failure (FAULT) | DO1 (fixed) | DO1 to DO6 (settable) |
| Calibration error (ALARM) | DO1 (fixed) | DO1 to DO6 (settable) |
| Rich mode | - | DO1 to DO6 (settable) |
| Reserved | - | DO1 to DO6 (settable) |

* For ALARM, "Enable" should be set to an alarm output.

Procedure:

- 1) Enter the <FACTORY MENU/DIGITAL OUT SET> screen.
- 2) Select the <DIGITAL OUT SET> screen by the  key.
- 3) Press the  key to enter the <DIGITAL OUT SET> screen.

Current setting is displayed.

- 4) Select DIGITAL OUT SET YES by the  or  key.

- 5) Press the  key to determine the setting.

Your setting is displayed.

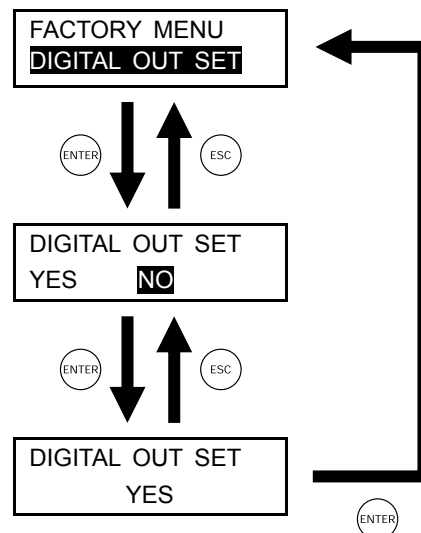

6.16 RBT contact setting

Purpose: To set a RBT contact specification [Normally closed (NC)].



The 4th digit of code symbol <when R or K is specified>

| 4th digit of code symbol | Case structure |
|--------------------------|--|
| R | RB spec. of bench type R-type thermocouple |
| K | RB spec. of bench type K-type thermocouple |

| Target for NC | Not target for NC |
|---------------------------|-------------------|
| Maintenance (MAINTE) | Blowdown (BLOW) |
| Calibration (MAINTE) | Span valve (SV) |
| H alarm (ALARM) | Zero valve (ZV) |
| L alarm (ALARM) | Rich mode |
| H-High alarm (ALARM) | |
| L-Low alarm (ALARM) | |
| Equipment failure (FAULT) | |
| Calibration error (ALARM) | |

List of targets for normally closed

Procedure:

- 1) Enter the <FACTORY MENU/RBT CONTACT> screen.
- 2) Select the <RBT CONTACT> screen by the  key.
- 3) Press the  key to enter the <RBT CONTACT> screen.

Current setting is displayed.

- 4) Change the current setting to RBT CONTACT YES by the  or  key.

- 5) Press the  key to determine the setting.
Your setting is displayed.

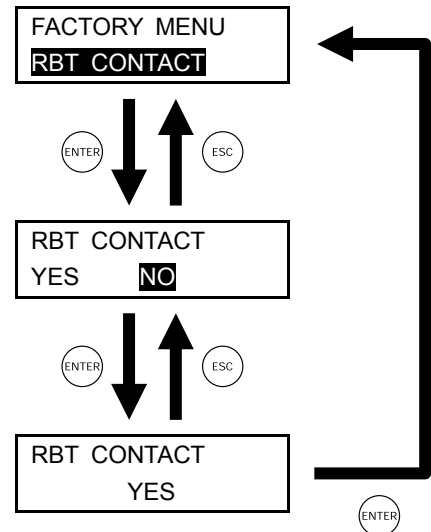



Entry of the option password is required to change this parameter.

6.17 Operation key setting

Purpose: To set the RBT operation key from 5 to 4.

Procedure:

- 1) Enter the <FACTORY MENU/OPERATION KEY> screen.
- 2) Select the <OPERATION KEY> screen by the  key.
- 3) Press the  key to enter the <OPERATION KEY> screen.

Current setting is displayed.

- 4) Change the setting to 4KEY by the  or  key.

- 5) Press the  key to determine the setting.

Your setting is displayed.

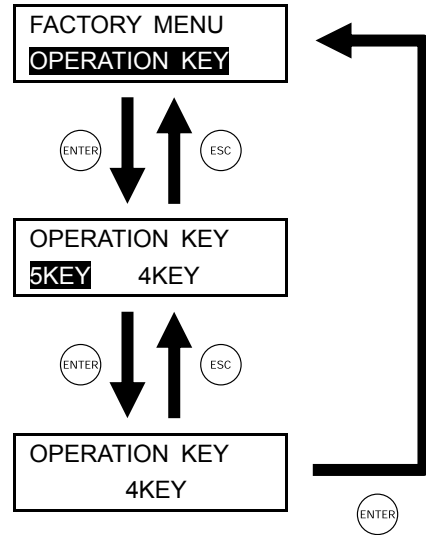





Entry of the option password is required to change this parameter.

6.18 Wire check start time setting

Purpose: To set the wire check time.

When the input signal is beyond 1150 mV, the alarm is output after the wire check time.
(Input signal may be 1150 mV or more at combustion initiation of furnace.)

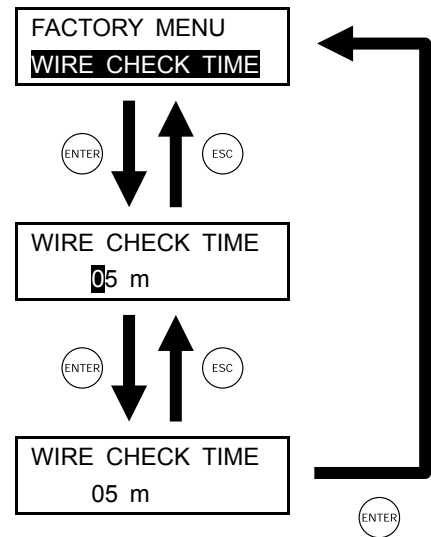

Procedure:

- 1) Enter the <FACTORY MENU/WIRE CHECK TIME> screen.
- 2) Select the <WIRE CHECK TIME> screen by the  key.
- 3) Press the  key to enter the <WIRE CHECK TIME> screen.
- 4) Current setting is highlighted.
- 5) Set the time by the  or  key and press the  key to determine.





6.19 Error check start time setting

Procedure:

- 1) Enter the <FACTORY MENU/ERR CHECK TIME> screen.
- 2) Select the <ERR CHECK TIME> screen by the  key.
- 3) Press the  key to enter the <ERR CHECK TIME> setting screen.

Current setting is highlighted.

- 4) Select time by the  key.
Selected time is highlighted.

- 5) Press the  key to determine the setting.
Your setting is displayed.

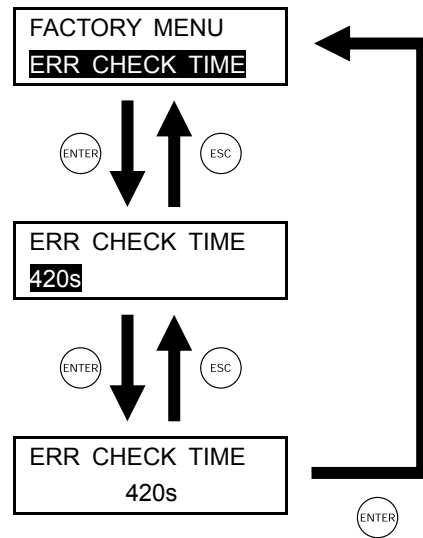

7. CALIBRATION BY A SIMULATION INPUT

Purpose: To calibrate SPAN/ZERO.

- Note:
- After adjustment of AD1 (O₂ sensor input), perform SPAN/ZERO calibration.
 - After Span calibration, perform Zero calibration.
 - SPAN/ZERO calibration are not available during warm-up operation or error (disconnection, abnormal heater temperature, etc.) occurrence.
 - Apply to AD2 (O₂ sensor thermocouple input) so that the heater temperature becomes 800°C.
The heater temperature to be displayed
= AD2 (Heater temperature input) + Room temperature. (Refer to “8.1 Table of reference thermal electromotive force of R-type thermocouple”)

7.1 Manual SPAN calibration

Procedure:

- 1) Enter the <CALIBRATION MENU/MANUAL SPAN CAL.> screen.
- 2) Select the <MANUAL SPAN CAL.> screen by the \blacktriangle key.
- 3) Press the ENTER key to enter the <MANUAL SPAN CAL.> screen.
- 4) Press the ENTER key after applied 0.000 mV DC (equivalent of 20.6 vol%) to "1 (+O₂)" and "2 (-O₂)" of external terminals.
* If SPAN gas concentration has been changed at “Calibration gas setting screen”, apply the voltage which falls into the set concentration.

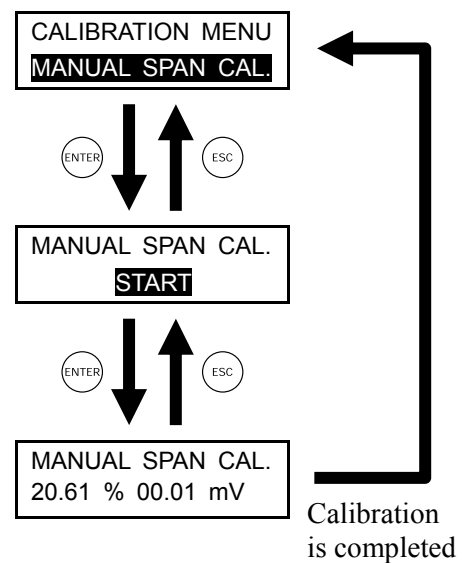

Oxygen concentration value and electromotive force of O₂ sensor are displayed during execution of manual SPAN calibration. When the calibration is completed successfully, the display transits to the menu screen.

7.2 Manual ZERO calibration

Procedure:

- 1) Enter the <CALIBRATION MENU/MANUAL ZERO CAL.> screen.
 - 2) Select the <MANUAL ZERO CAL.> screen by the \blacktriangle key.
 - 3) Press the ENTER key to enter the <MANUAL ZERO CAL.> screen.
 - 4) Press the ENTER key while applying 51.39 mV DC (2.0 vol%) to "1 (+O₂)" and "2 (-O₂)" of external terminals.
- * If ZERO gas concentration has been changed at "Calibration gas setting screen", after applied the voltage which falls into the set concentration.

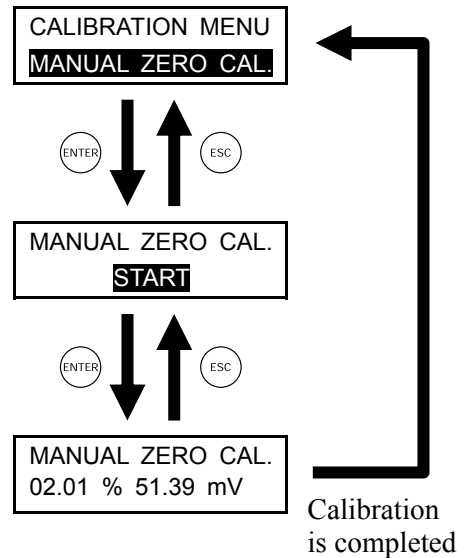

Oxygen concentration value and electromotive force of O₂ sensor are displayed during execution of manual ZERO calibration. When the calibration is completed successfully, the display transits to the menu screen.

8. APPENDED FIGURES

8.1 Table of reference thermal electromotive force of R-type thermocouple

Unit : mV JIS C 1602-1995

| Temperature (°C) | 0 | 100 | 200 | 300 | 400 | 500 | 600 | 700 | 800 | 900 |
|------------------|-------|-------|-------|-------|-------|-------|-------|-------|-------|--------|
| 0 | 0.000 | 0.647 | 1.469 | 2.401 | 3.408 | 4.471 | 5.583 | 6.743 | 7.950 | 9.205 |
| 10 | 0.054 | 0.723 | 1.558 | 2.498 | 3.512 | 4.580 | 5.697 | 6.861 | 8.073 | 9.333 |
| 20 | 0.111 | 0.800 | 1.648 | 2.597 | 3.616 | 4.690 | 5.812 | 6.980 | 8.197 | 9.461 |
| 30 | 0.171 | 0.879 | 1.738 | 2.696 | 3.721 | 4.800 | 5.926 | 7.100 | 8.321 | 9.590 |
| 40 | 0.232 | 0.959 | 1.831 | 2.796 | 3.827 | 4.910 | 6.041 | 7.220 | 8.446 | 9.720 |
| 50 | 0.296 | 1.041 | 1.923 | 2.896 | 3.933 | 5.021 | 6.157 | 7.340 | 8.571 | 9.850 |
| 60 | 0.363 | 1.124 | 2.017 | 2.997 | 4.040 | 5.133 | 6.273 | 7.461 | 8.697 | 9.980 |
| 70 | 0.431 | 1.208 | 2.112 | 3.099 | 4.147 | 5.245 | 6.390 | 7.583 | 8.823 | 10.111 |
| 80 | 0.501 | 1.294 | 2.207 | 3.201 | 4.255 | 5.357 | 6.507 | 7.705 | 8.950 | 10.242 |
| 90 | 0.573 | 1.381 | 2.304 | 3.304 | 4.363 | 5.470 | 6.625 | 7.827 | 9.077 | 10.374 |
| 100 | 0.647 | 1.469 | 2.401 | 3.408 | 4.471 | 5.583 | 6.743 | 7.950 | 9.205 | 10.506 |

8.2 Table of reference thermal electromotive force of K-type thermocouple

Unit : mV JIS C 1602-1995

| Temperature (°C) | 0 | 100 | 200 | 300 | 400 | 500 | 600 | 700 | 800 | 900 |
|------------------|-------|-------|--------|--------|--------|--------|--------|--------|--------|--------|
| 0 | 0 | 4.096 | 8.138 | 12.209 | 16.397 | 20.644 | 24.905 | 29.129 | 33.275 | 37.326 |
| 10 | 0.397 | 4.509 | 8.539 | 12.624 | 16.820 | 21.071 | 25.330 | 29.548 | 33.685 | 37.725 |
| 20 | 0.798 | 4.920 | 8.940 | 13.040 | 17.243 | 21.497 | 25.755 | 29.965 | 34.093 | 38.124 |
| 30 | 1.203 | 5.328 | 9.343 | 13.457 | 17.667 | 21.924 | 26.179 | 30.382 | 34.501 | 38.522 |
| 40 | 1.612 | 5.735 | 9.747 | 13.874 | 18.091 | 22.350 | 26.602 | 30.798 | 34.908 | 38.918 |
| 50 | 2.023 | 6.138 | 10.153 | 14.293 | 18.516 | 22.776 | 27.025 | 31.213 | 35.313 | 39.314 |
| 60 | 2.436 | 6.540 | 10.561 | 14.713 | 18.941 | 23.203 | 27.447 | 31.628 | 35.718 | 39.708 |
| 70 | 2.851 | 6.941 | 10.971 | 15.133 | 19.366 | 23.629 | 27.869 | 32.041 | 36.121 | 40.101 |
| 80 | 3.267 | 7.340 | 11.382 | 15.554 | 19.792 | 24.055 | 28.289 | 32.453 | 36.524 | 40.494 |
| 90 | 3.682 | 7.739 | 11.795 | 15.975 | 20.218 | 24.480 | 28.710 | 32.865 | 36.925 | 40.885 |
| 100 | 4.096 | 8.138 | 12.209 | 16.397 | 20.644 | 24.905 | 29.129 | 33.275 | 37.326 | 41.276 |

8.3 Table of theory output of zirconia oxygen detector

| O ₂ conc. % | Output mV | O ₂ conc. % | Output mV | O ₂ conc. % | Output mV | O ₂ conc. % | Output mV | O ₂ conc. % | Output mV |
|------------------------|-----------|------------------------|-----------|------------------------|-----------|------------------------|-----------|------------------------|-----------|
| 0.01 | 168.15 | 0.9 | 68.99 | 5.5 | 29.10 | 20 | 0.651 | 36 | -12.30 |
| 0.02 | 152.87 | 1.0 | 66.67 | 6.0 | 27.18 | 20.6 | 0.000 | 37 | -12.91 |
| 0.03 | 143.94 | 1.2 | 62.65 | 6.5 | 25.42 | 21 | -0.4238 | 38 | -13.49 |
| 0.04 | 137.6 | 1.4 | 59.25 | 7.0 | 23.79 | 22 | -1.449 | 39 | -14.06 |
| 0.05 | 132.68 | 1.5 | 57.73 | 7.5 | 22.27 | 23 | -2.428 | 40 | -14.62 |
| 0.06 | 128.66 | 1.6 | 56.31 | 8.0 | 20.84 | 24 | -3.366 | 41 | -15.17 |
| 0.07 | 125.27 | 1.8 | 53.71 | 9.0 | 18.25 | 25 | -4.266 | 42 | -15.70 |
| 0.08 | 122.32 | 2.0 | 51.39 | 10.0 | 15.93 | 26 | -5.130 | 43 | -16.22 |
| 0.09 | 119.73 | 2.2 | 49.29 | 11.0 | 13.83 | 27 | -5.962 | 44 | -16.72 |
| 0.1 | 117.41 | 2.4 | 47.37 | 12 | 11.91 | 28 | -6.763 | 45 | -17.22 |
| 0.2 | 102.13 | 2.6 | 45.61 | 13 | 10.14 | 29 | -7.537 | 46 | -17.70 |
| 0.3 | 93.20 | 2.8 | 43.98 | 14 | 8.511 | 30 | -8.284 | 47 | -18.18 |
| 0.4 | 86.86 | 3.0 | 42.46 | 15 | 6.991 | 31 | -9.01 | 48 | -18.64 |
| 0.5 | 81.94 | 3.5 | 39.06 | 16 | 5.569 | 32 | -9.71 | 49 | -19.10 |
| 0.6 | 77.92 | 4.0 | 36.12 | 17 | 4.233 | 33 | -10.38 | 50 | -19.54 |
| 0.7 | 74.53 | 4.5 | 33.52 | 18 | 2.973 | 34 | -11.04 | | |
| 0.8 | 71.58 | 5.0 | 31.20 | 19 | 1.782 | 35 | -11.68 | | |

$$E \text{ (mV)} = 50.74 \log_{20.6}/x$$

8.4 Key operation flow diagram

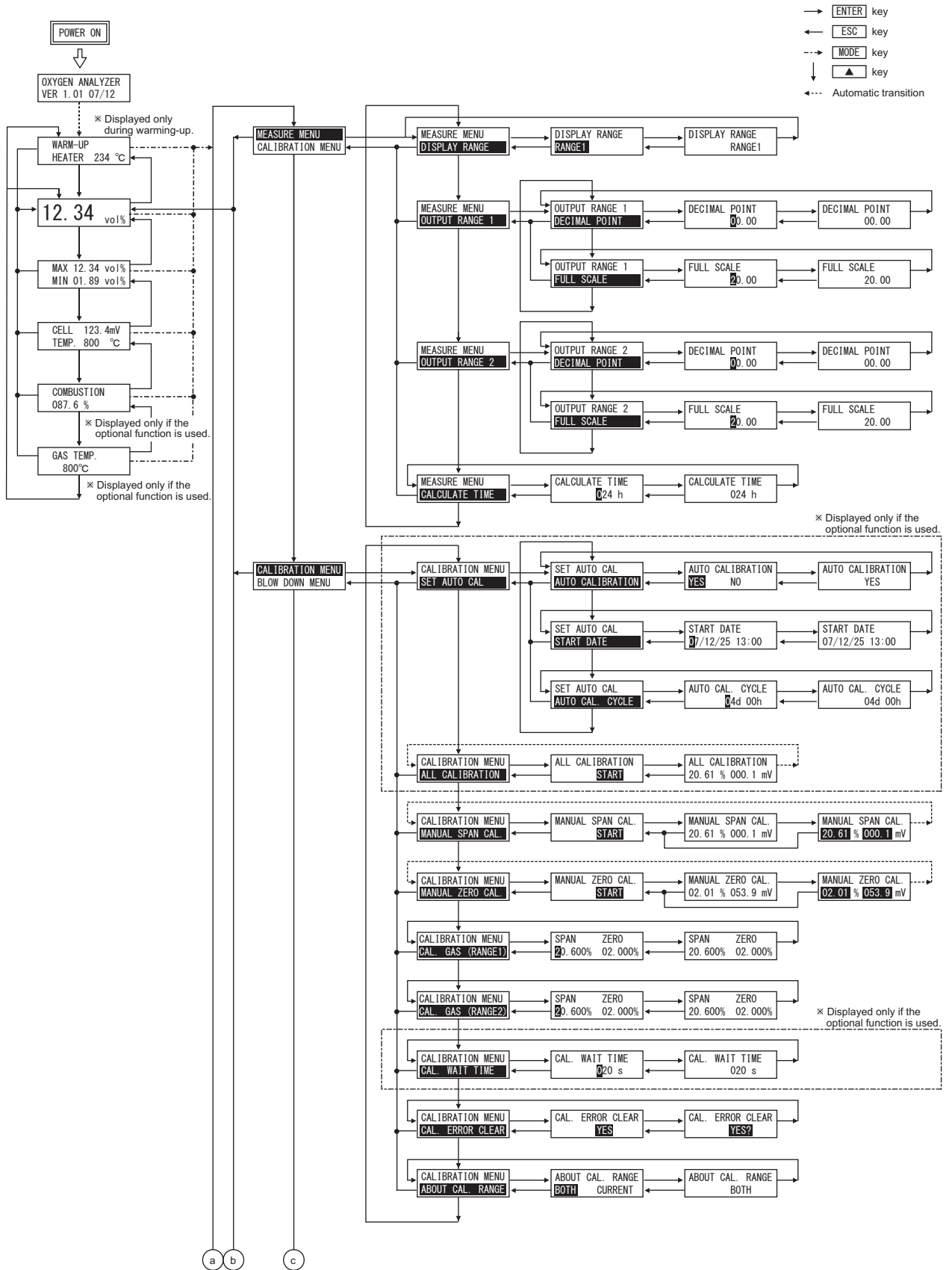

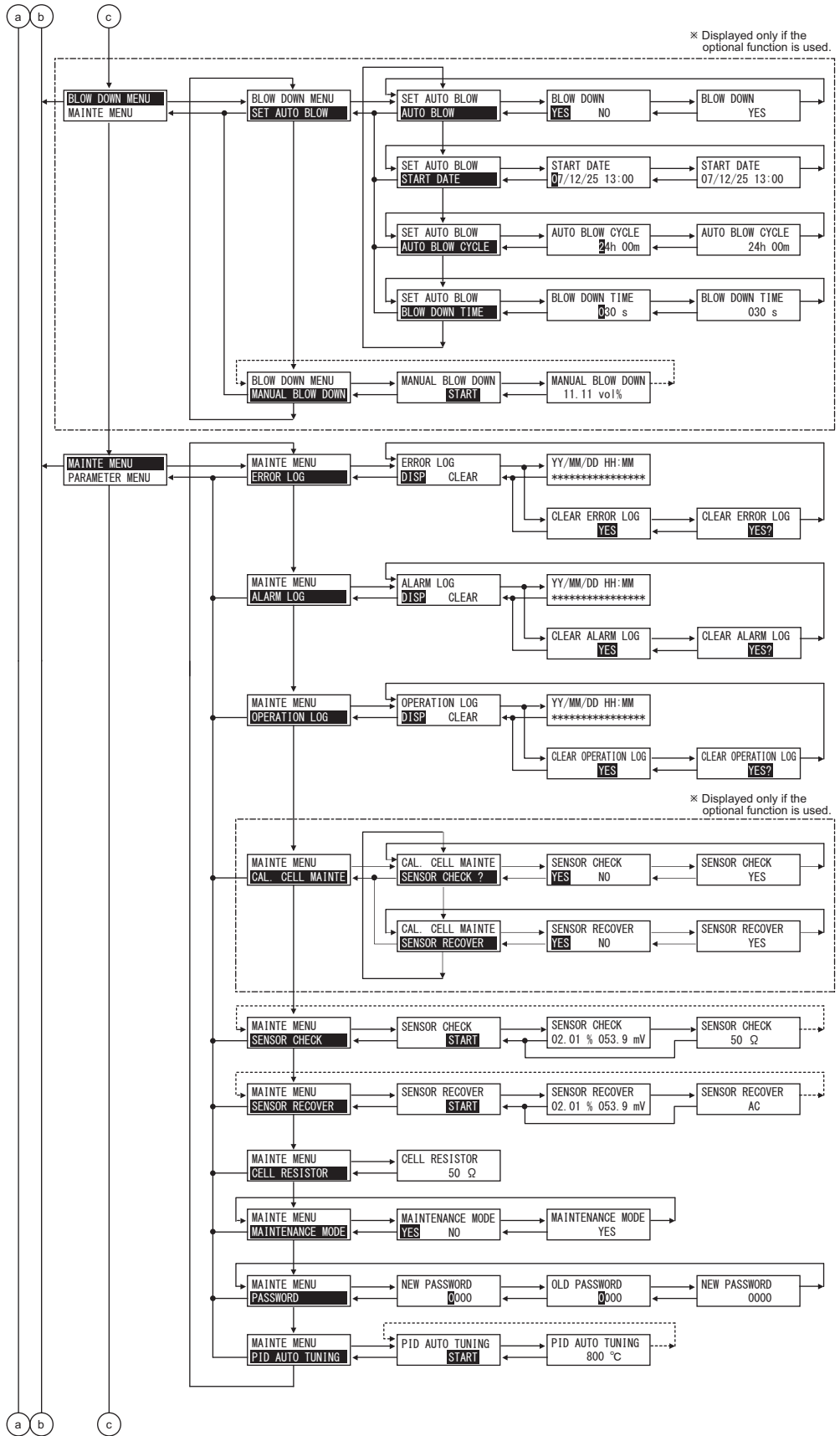

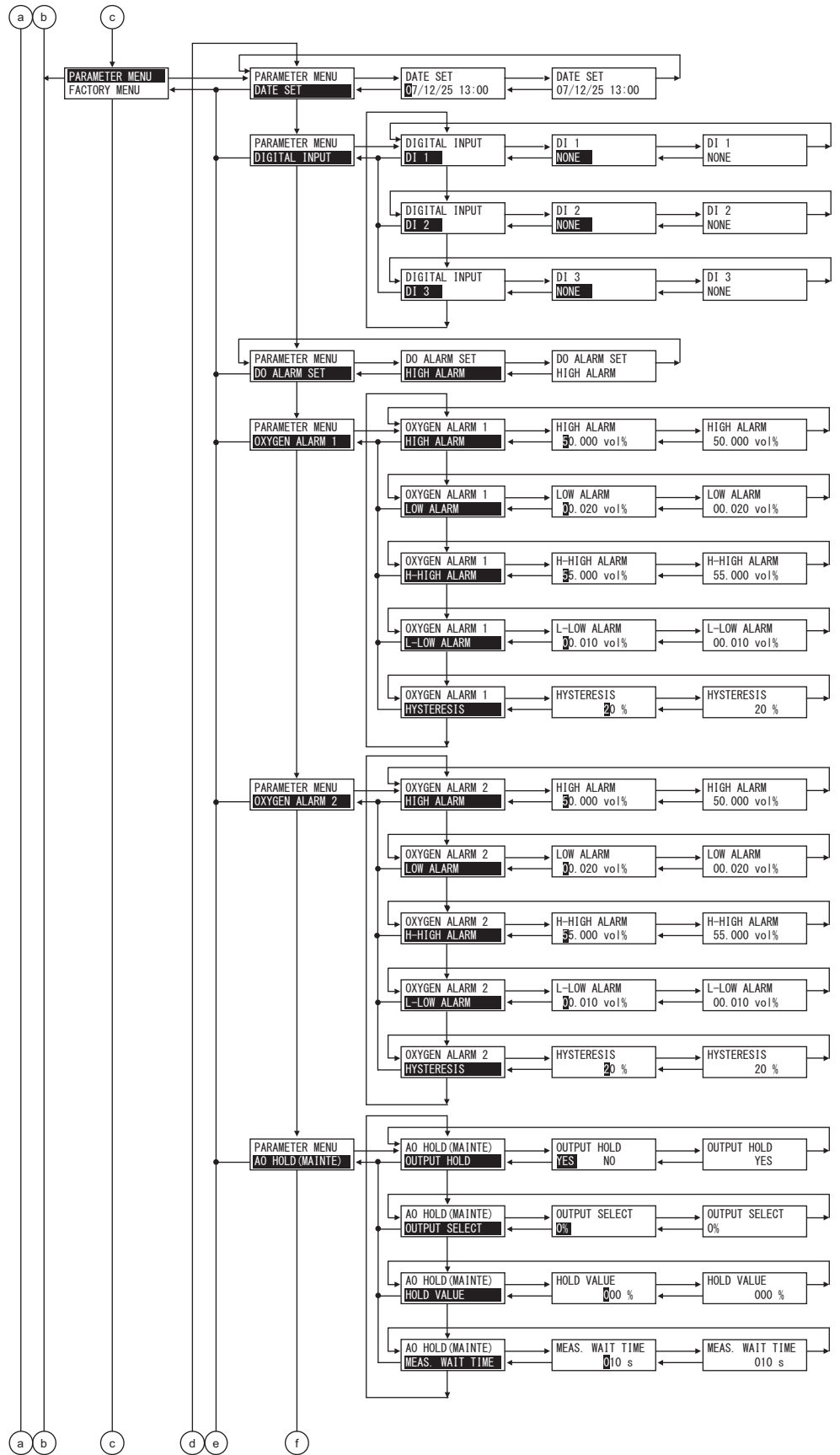

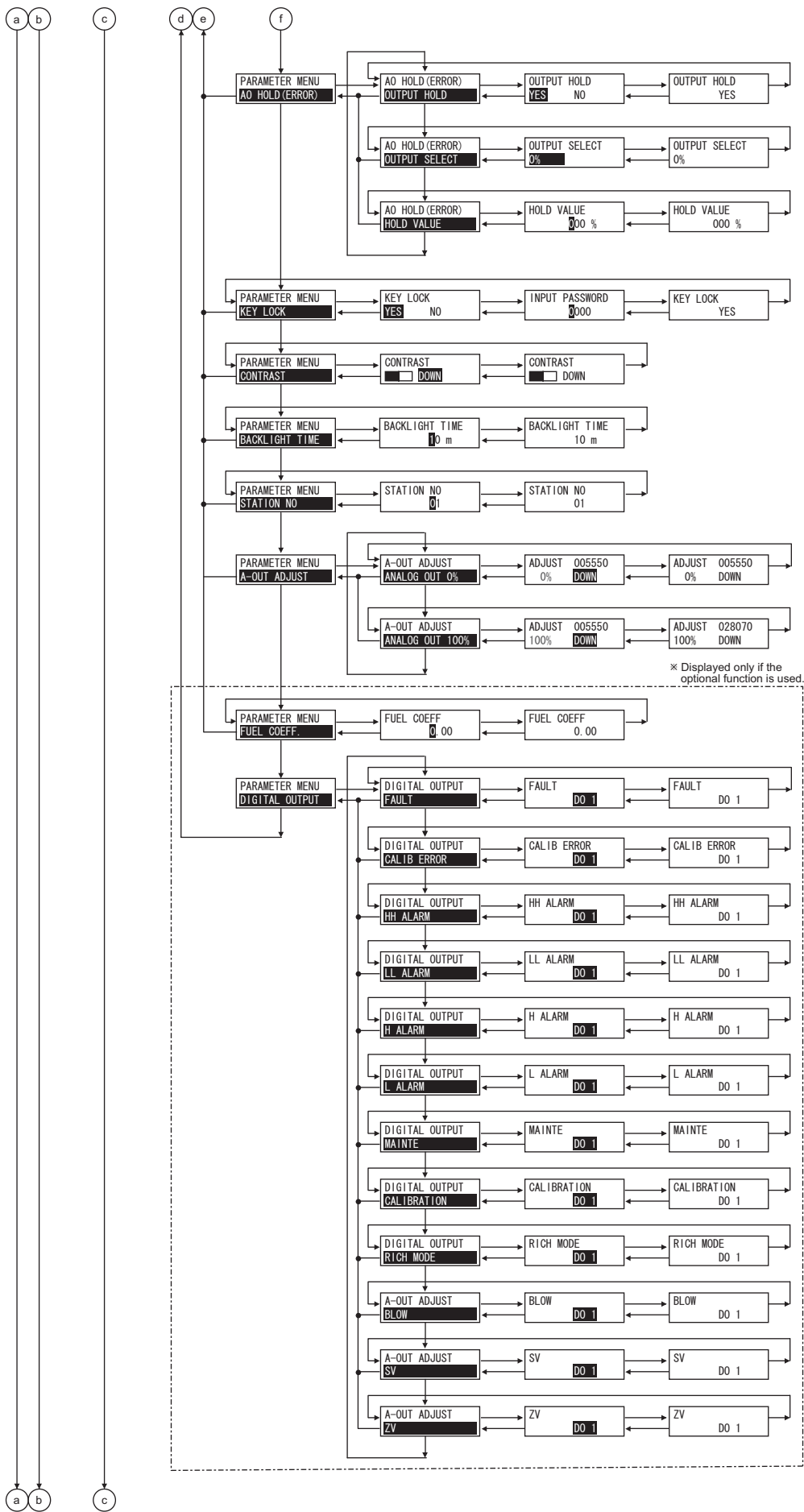

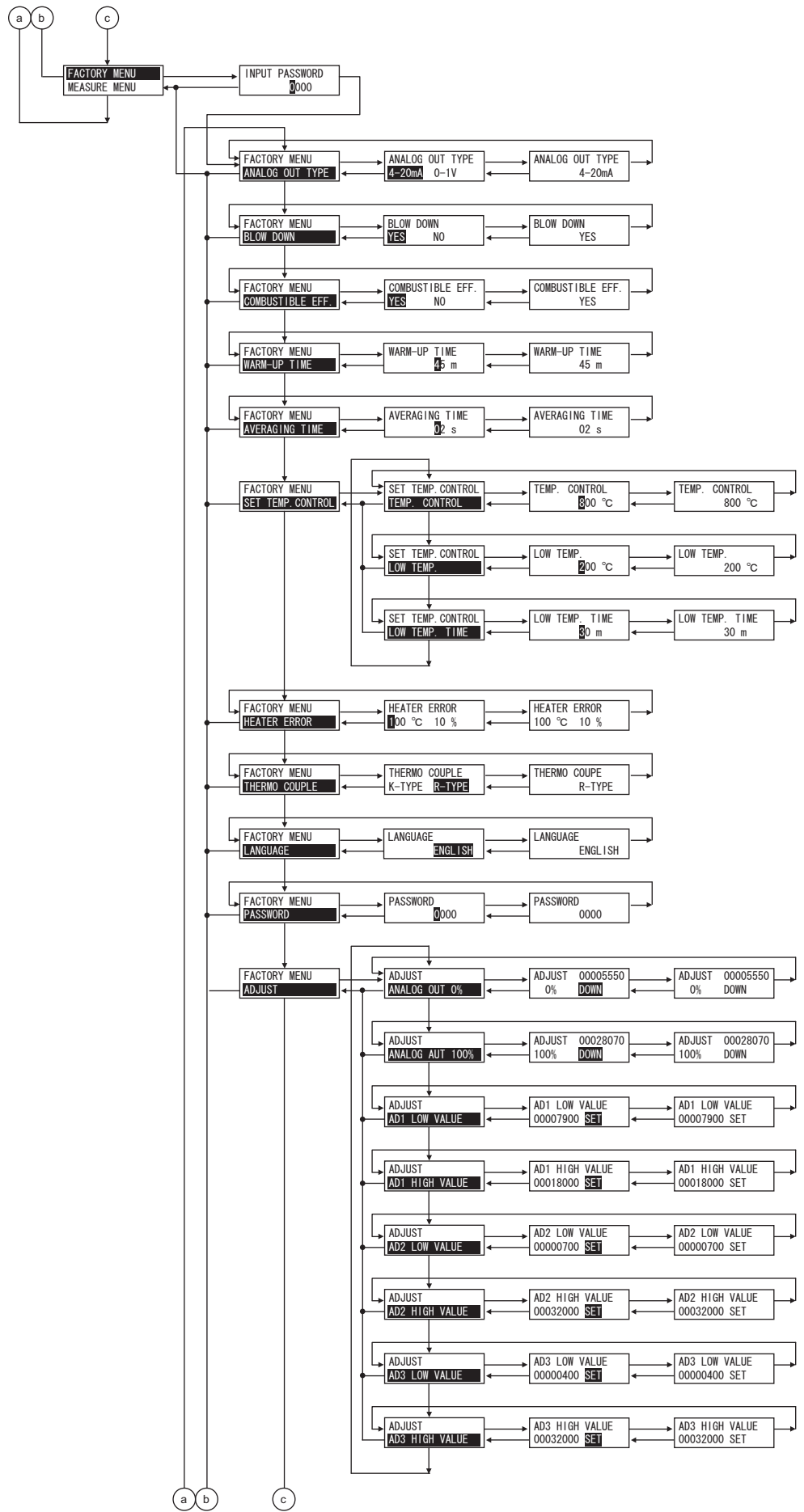

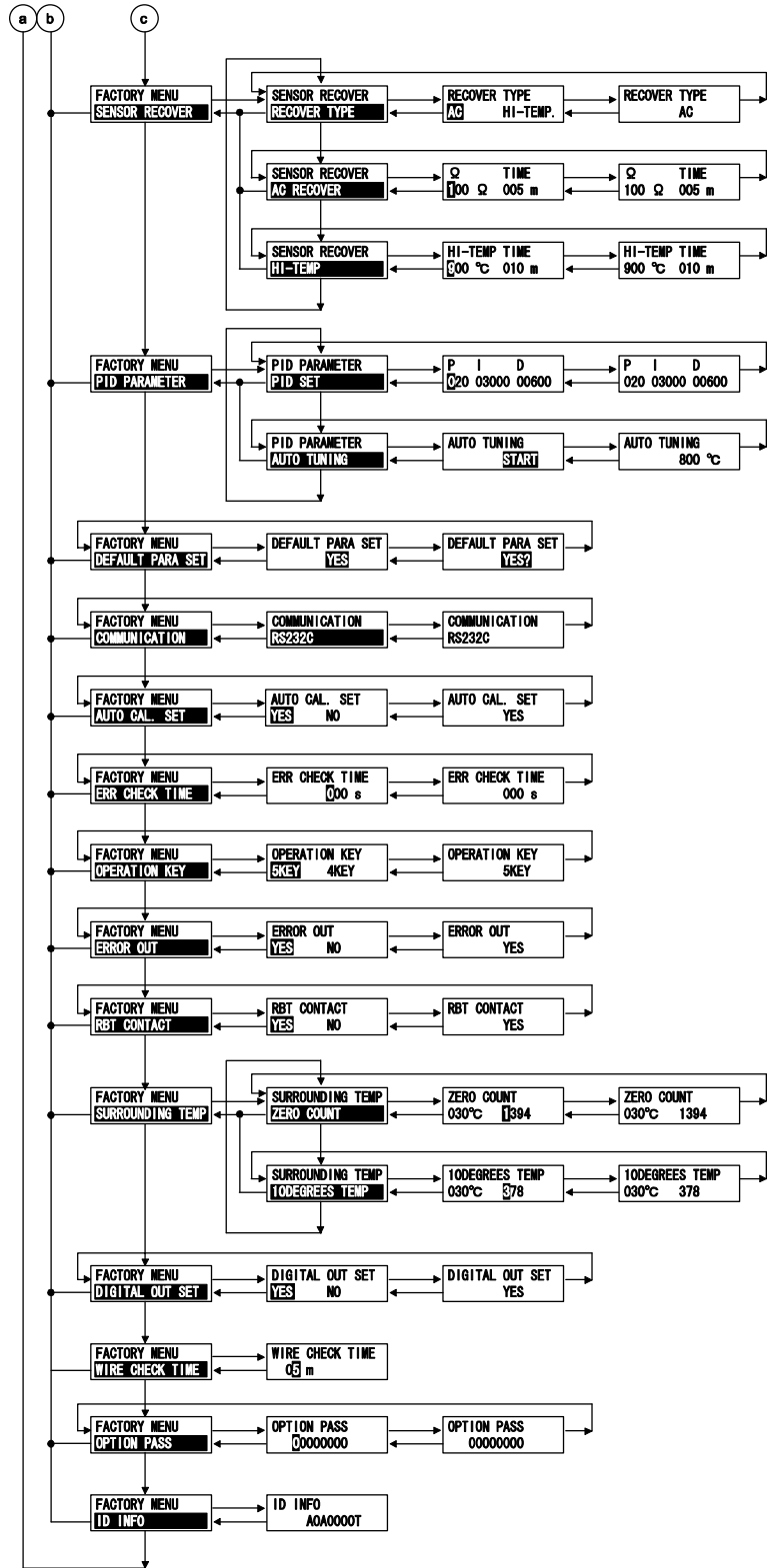

Fuji Electric Co., Ltd.

International Sales Div

Sales Group

Gate City Ohsaki, East Tower, 11-2, Osaki 1-chome,
Shinagawa-ku, Tokyo 141-0032, Japan
<http://www.fujielectric.com>
Phone: 81-3-5435-7280, 7281 Fax: 81-3-5435-7425
<http://www.fujielectric.com/products/instruments/>
