



Service Manual – Gemini IntelliFresh Satellite

Important Safeguards/Symbols

This appliance is designed for commercial use. Any servicing other than cleaning and preventive maintenance should be performed by an authorized Wilbur Curtis service technician.

- DO NOT immerse the unit in water or any other liquid
- To reduce the risk of fire or electric shock, DO NOT open service panels. No user serviceable parts inside.
- Keep hands and other items away from hot surfaces of unit during operation.
- Never clean with scouring powders, bleach or harsh chemicals.

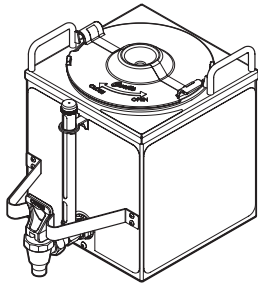

Model
• GEM3IF

Symbols



WARNINGS – To help avoid personal injury



Important Notes/Cautions – from the factory



Sanitation Requirements

IntelliFresh Function & Features

The IntelliFresh system will alert you when the coffee has exceeded the desired holding time. The Intellifresh system is activated by a connector on the Satellite coming into contact with a corresponding connector on the center panel. IntelliFresh is adjustable through the UCM control panel on the brewer.

Quality Timer (Factory Set to 2 hours)

Press **⊙** to select, press **<** or **>** to choose desired setting. Range 20 min. to 240 min. The timer is intended to notify the user when the coffee loses its freshness. The indicator light (LED) on the satellite will remain solid red until the Quality Timer expires (Factory Set to 2 hours). At expiration the LED will flash and remain flashing at the factory setting for an additional 8 hours. The additional 8 hours is controlled by the Warmer Auto-Off setting.

- Setting Range: 20 – 240 minutes. The default time is 2 hours.
- Time Expiration Indicator: LED flashes after expiration of Quality Timer Setting for up to a total of 12 hours. The default time is 8 hours after expiration of the Quality Timer.

Warmer Auto-Off (factory set to 10 Hrs.)

Press **⊙** to select **<** or **>** to adjust from 1-12 hours. This feature has higher priority than the Quality Timer. It shuts off the warmers after a pre-determined time factory set at 10 hours starting when the Brew Button is pushed. The Quality Timer does not affect this function.

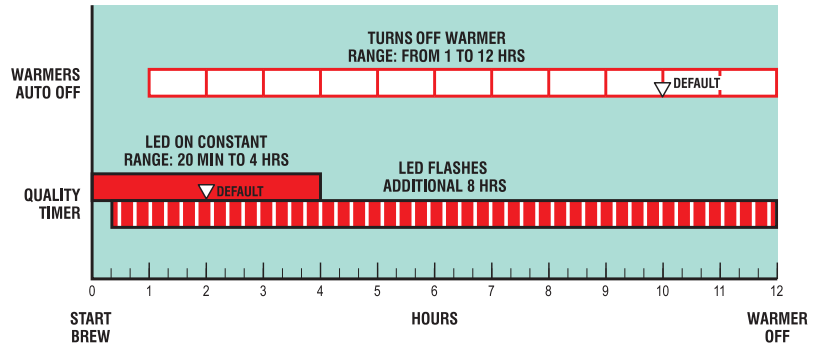

Error Codes:

1. Three long blinks & one short blink = heater error.
2. Three long blinks & two short blinks = sensor error

Warmers

The warmers, will turn on automatically whenever a coffee brew cycle is started. The temperature of the warmers are controlled at the warmer buttons on the control panel.

The G3 UCM is shown on the left side and the G4 touch screen UCM is on the right.

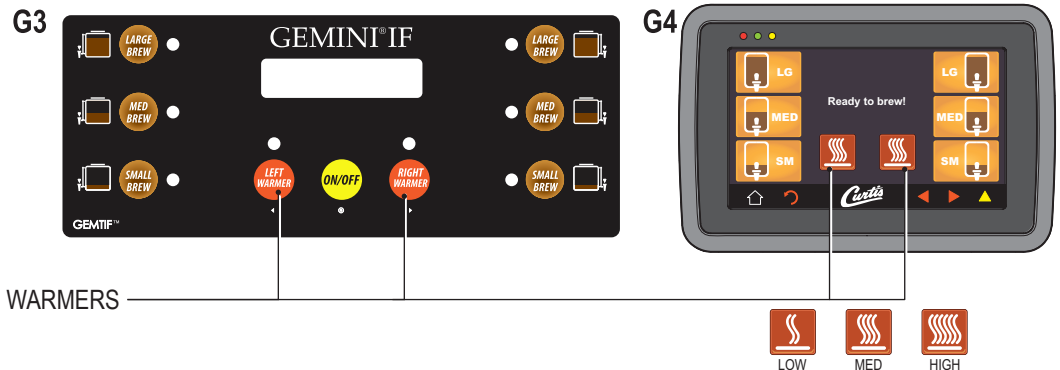

Illustrated Parts List
GEM31F

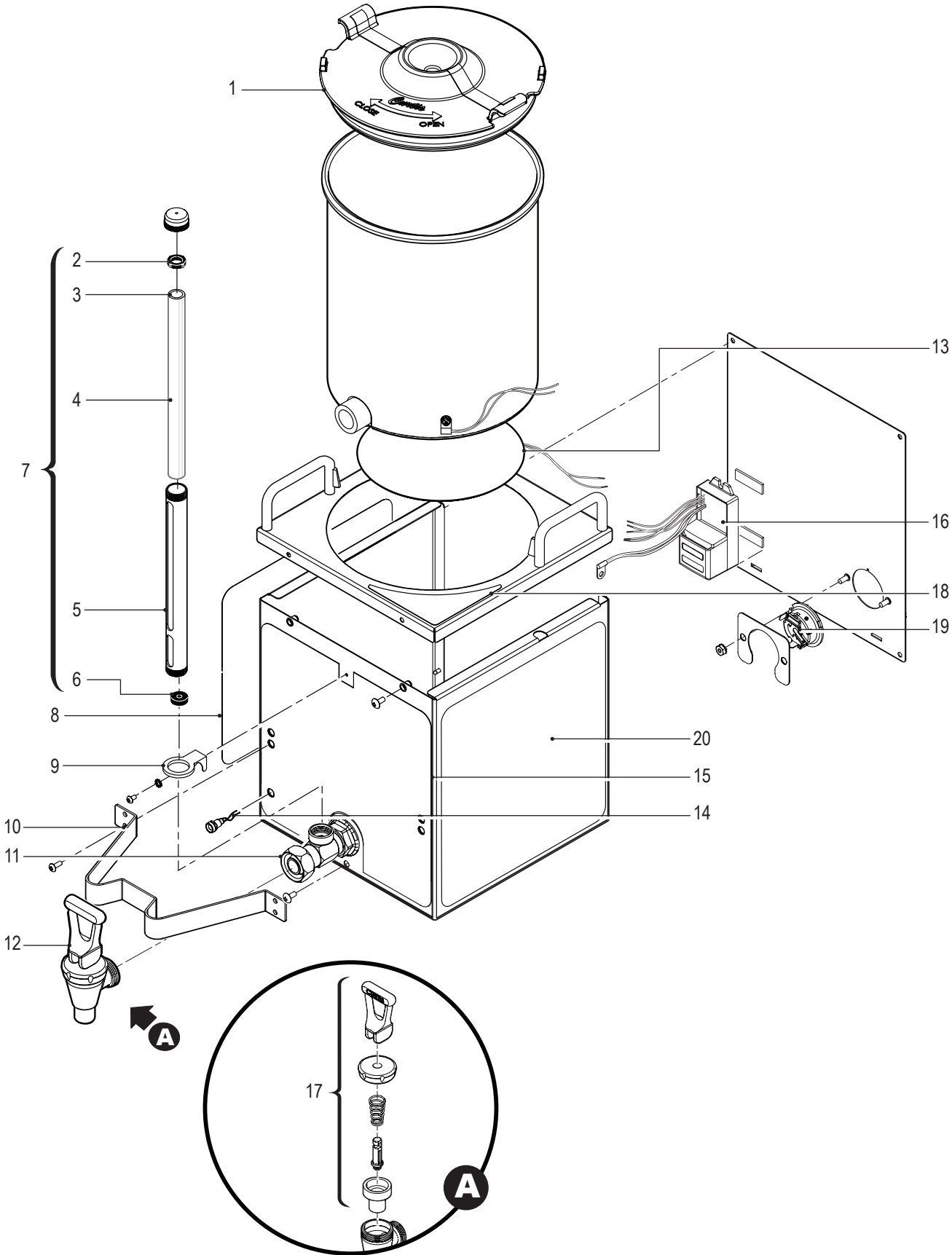

Illustrated Parts List GEM3IF

Index No	Part No	Description
1	WC-5622*	LID, BLACK PLASTIC GEM-3
2	WC-2001	CAP, SHIELD W/VENT
3	WC-2005*	WASHER, SHIELD CAP 1/8"
4	WC-2025*	GLASS, GAUGE 8"
5	WC-2010C	SHIELD, GAUGE GLASS 3/4" D. x 8"
6	WC-2006*	WASHER, .188ID x .188 THK BOTTOM
7	WC-2102	GAUGE GLASS ASSEMBLY 8"
8	WC-39747	LABEL, SIDE GEM3IF CURTIS LOGO
9	WC-2007	BRACKET, GAUGE GLASS GEM-3
10	WC-6417	GUARD, FAUCET GEM-3
11	WC-1901A	SHANK, FAUCET W/SHIELD BASE
11A	WC-1901A-103K**	KIT, SHANK ASSY, FAUCET W/ SHIELD BASE & O-RING
12	WC-1800*	FAUCET, S' SERIES NON-LOCKING
13	WC-37543*	KIT, INTELLIFRESH HEATER GEM3IF
13A	WC-37552**	KIT, INTELLIFRESH HEATER WC-981 GEM3IF
14	WC-37544*	KIT, LED LIGHT GEM3IF
15	WC-39746	LABEL, FRONT GEM3IF CURTIS LOGO
16	WC-37545*	KIT, HYBRID TEMPERATURE CONTROL
17	WC-3705*	KIT, FAUCET S' SERIES
18	WC-38151	LABEL, LOCK/UNLOCK GEM3
19	WC-13426	IF CONNECTOR, FEMALE W/WIRES
20	WC-39747	LABEL, SIDE GEM-3IF CURTIS LOGO

* SUGGESTED PARTS TO STOCK

** FOR UNITS BUILT AFTER 3/2015

Cleaning the GEM3IF Satellite

A daily routine of cleaning the GEM3IF Satellite will maintain the appearance of the unit and ensure great tasting coffee. To clean the Satellite components, prepare a mild solution of detergent and warm water.



CAUTION – Do not use cleansers, liquids containing bleach, powders or any other substance containing chlorine. These products promote corrosion and will pit the stainless steel. USE OF THESE PRODUCTS WILL VOID THE WARRANTY.

DO NOT immerse the Satellite in water or any other liquid.

1. Remove lid from Satellite. Clean the lid at the funnel area with a spiral brush and detergent solution.
2. Rinse the lid, removing all traces of cleaning solution.
3. Clean inside of the Satellite. Remove coffee residue with the detergent solution.
4. Thoroughly rinse out the Satellite with clean warm water.
5. Unscrew the handle/bonnet assembly and remove it from the dispensing faucet.
6. Inspect the silicone seat cup for wear, cracks, or hardening. If okay, then leave the seat cup attached on the handle/bonnet assembly. Soak then wipe clean. Replace the seat cup if damaged.
7. Remove the gauge glass tube by unscrewing the gauge glass cap.
8. Clean the gauge glass tube with a gauge brush soaked with detergent solution. Soak and wipe the two washers. Rinse with clean water. Dry the parts and assemble them onto the Satellite. Hand tighten the cap.
9. Clean all parts. Thoroughly rinse with clean warm water.
10. Dry and assemble the parts. Hand-tighten when the assembling.

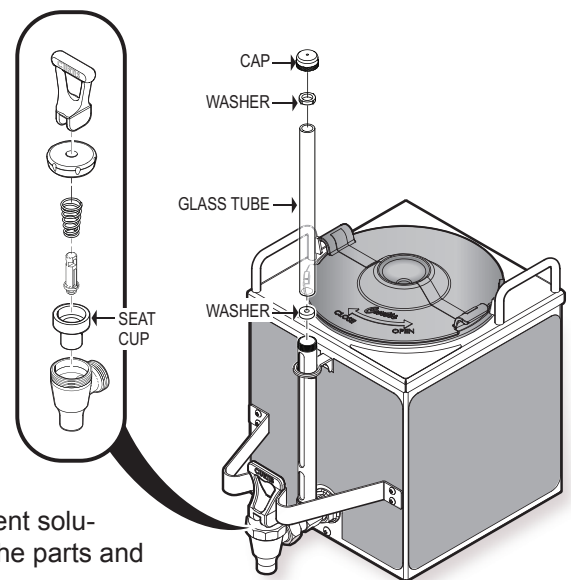

Electrical Schematic

GEM3IF

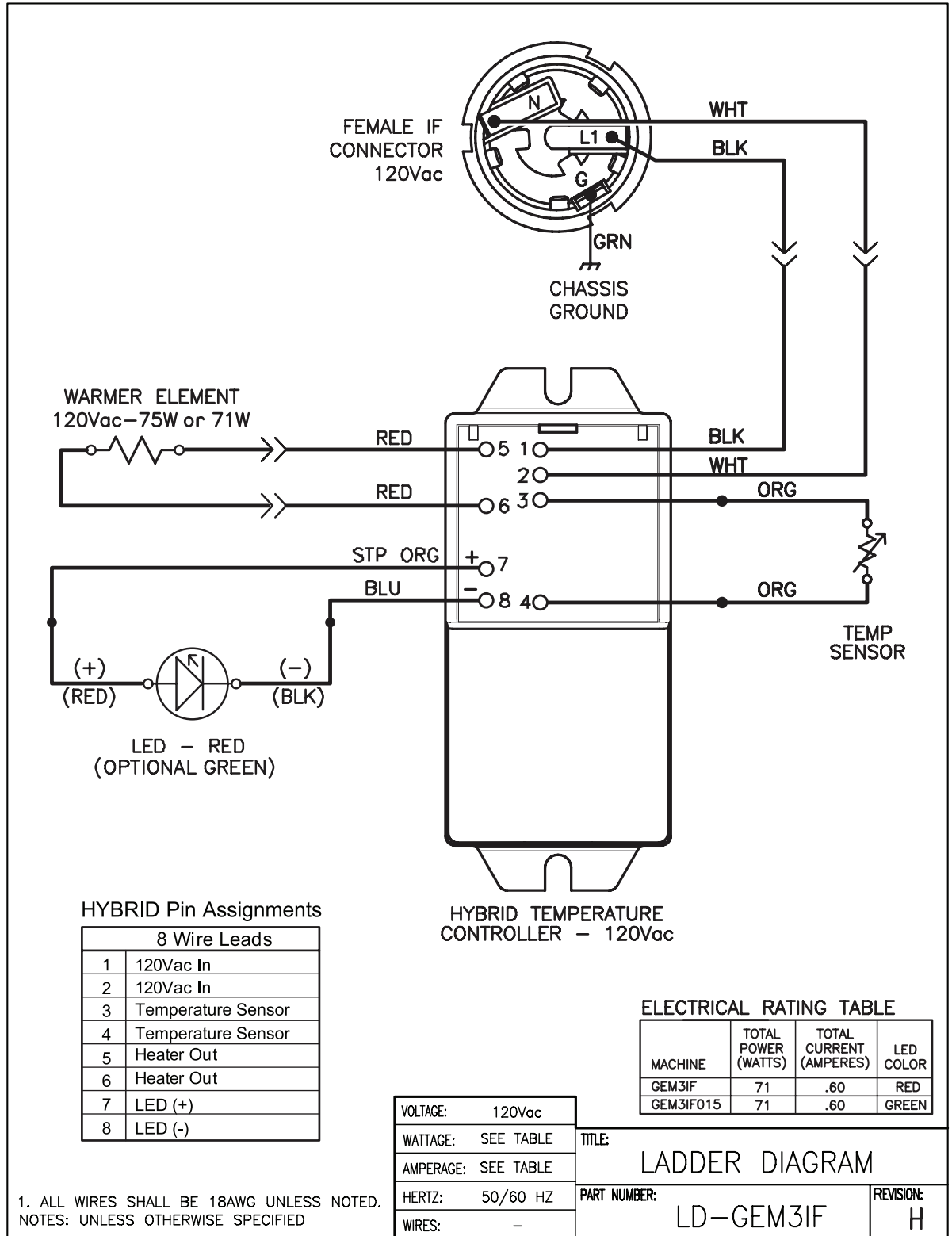

ECN 15984 . 9/24/14@9.8



WILBUR CURTIS CO., INC.

6913 Acco St., Montebello, CA 90640-5403 USA
 Phone: 800/421-6150 Fax: 323-837-2410
 Technical Support Phone: 800/995-0417 (M-F 5:30A - 4:00P PST)
 Web Site: www.wilburcurtis.com

E-Mail: techsupport@wilburcurtis.com