

MODEL

**H 65SC**

**HITACHI**  
**POWER TOOLS**

**HAMMER**  
**H 65SC**

**TECHNICAL DATA**  
**AND**  
**SERVICE MANUAL**

**H**

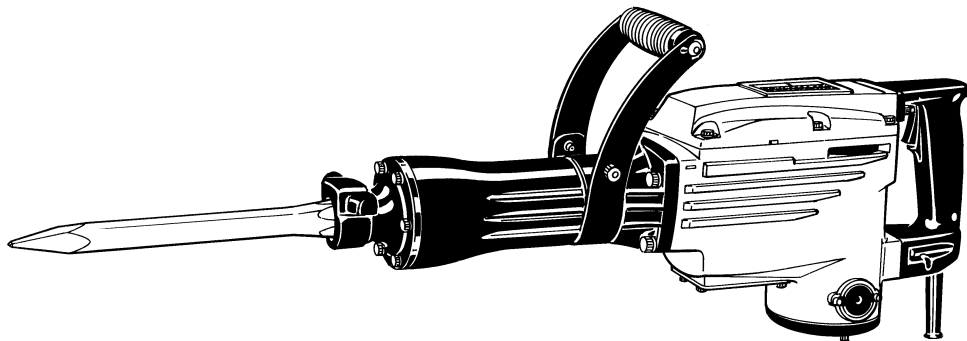

LIST No. E451

Nov. 1999

REMARK:

Throughout this TECHNICAL DATA AND SERVICE MANUAL, a symbol(s) is(are) used in the place of company name(s) and model name(s) of our competitor(s). The symbol(s) utilized here is(are) as follows:

Symbols Utilized	Competitors	
	Company Name	Model Name
C-1	MAKITA	HM1303
C-2	MAKITA	HM1500

**Notice for use**

Specifications and parts are subject to change for improvement.  
Refer to Hitachi Power Tool Technical News for further information.

**CONTENTS**

<b>[ Business Section ]</b>	<b>Page</b>
<b>1. PRODUCT NAME</b> .....	1
<b>2. MARKETING OBJECTIVE</b> .....	1
<b>3. APPLICATIONS</b> .....	1
<b>4. SELLING POINTS</b> .....	1
4-1. Selling Point Descriptions .....	2
<b>5. SPECIFICATIONS</b> .....	3
5-1. Optional Accessories .....	4
<b>6. COMPARISONS WITH SIMILAR PRODUCTS</b> .....	6
6-1. Specification Comparisons .....	6
6-2. Demolition Performance Comparisons .....	6
<b>7. PRECAUTIONS IN SALES PROMOTION</b> .....	7
7-1. Handling Instructions .....	7
7-2. Caution Plate .....	7
7-3. Oil Supply .....	7
7-4. Impact Performance at Low Temperatures .....	8
<b>8. REFERENCE INFORMATION</b> .....	9
8-1. Structure of the Main Body .....	9
8-2. Stop Lever [Tool Retainer] .....	9
8-3. Movement of the Stop Lever .....	10
8-4. No-load Striking Preventive Mechanism .....	10
<b>[ Service Section ]</b>	
<b>9. REPAIR GUIDE</b> .....	10
9-1. Precautions and Suggestions for Disassembly and Reassembly of the Main Body .....	10
9-1-1. Disassembly .....	10
9-1-2. Reassembly .....	13
9-1-3. Screw Locking Agent TB1401 .....	16
9-1-4. Tightening Torque .....	16
9-1-5. Internal Wiring .....	16
9-1-6. Insulation Tests .....	17
9-1-7. No-Load Current Value .....	17
<b>10. STANDARD REPAIR TIME (UNIT) SCHEDULES</b> .....	18
<b>[ Appendix ]</b>	
Assembly Diagram for H 65SC .....	19

## 1. PRODUCT NAME

Hitachi Electric Hammer, Model H 65SC

## 2. MARKETING OBJECTIVE

The Model H 65SC is a double-insulated version of the existing single-insulated Model PH-65A. It has a recirculating lubricating system. Demolishing and chipping power is comparable to that of the PH-65A, as is the basic structure. The main features of the Model H 65SC is as follows:

- (1) Highest demolition performance in this class.
- (2) Durable, Aluminum-die-cast Housing for longer service life.
- (3) Lower consumption motor design.

## 3. APPLICATIONS

- Demolishing of concrete and similar materials.
- Groove and channel digging in concrete.
- Groove and channel digging in asphalt and gravel roads.
- Tamping/compacting of asphalt and graveled roads.
- Cutting of asphalt.

[Typical Applications]

Constructions work, piping/wiring work, water supply/drain work, etc.

## 4. SELLING POINTS

Maker • Model	Weight	Overall length
HITACHI H 65SC	15 kg (33.1 lbs.)	647 mm (25-15/32")
HITACHI PH-65A	15 kg (33.1 lbs.)	642 mm (25-9/32")
C-1	14 kg (30.9 lbs.)	675 mm (26-37/64")
C-2	17 kg (37.5 lbs.)	647 mm (25-15/32")

Largest demolition performance in this class.

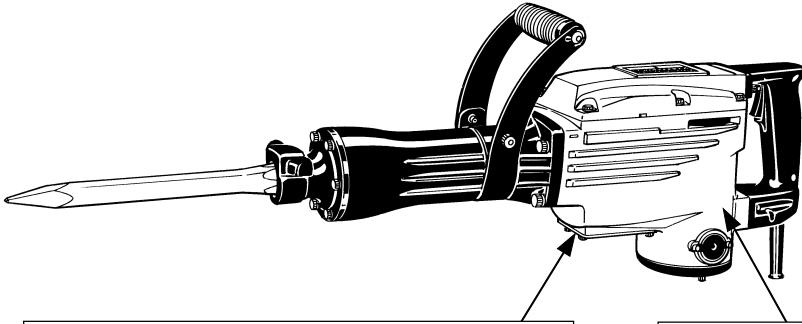

Automatic lubricator permits operating over extended periods without supplying oil.

Internal double-insulation construction with rugged aluminum frame.

#### 4-1. Selling Point Descriptions

##### 4-1-1. Largest demolition performance in this class

Demolition performance is 1.1 to 1.3 times larger than that of similar products thanks to the maximum 39.5 J impact energy and efficient striking.

Maker • Model	Ratio of demolished weight (%)
HITACHI H 65SC	100
HITACHI PH-65A	100
C-1	80
C-2	92

## 5. SPECIFICATIONS

Item	H 65SC	
Power source	Single-phase AC 50/60 Hz	
Voltage (V)	110, 115, 230, 240	
Motor type	AC single-phase series commutator motor	
Insulation structure	Double insulation	
Enclosure	Materials: Aluminum alloy die casting Cast aluminum alloy Glass-fiber reinforced plastic resin Paint: Hammer-net silver green and black	
Switch	Trigger switch (with stopper)	
Type of handles	D-shaped handle and side handle	
Full-load current	11.8 A (110 V), 11.4 A (115 V), 5.7 A (230 V), 5.4 A (240 V)	
Power input	1,240 W	
Striking speed	No-load	1,800 /min.
	Full-load	1,400 /min.
Weight	Product: 15.0 kg (33.1 lbs.); excluding cord Packed: 23.5 kg (51.8 lbs.)	
Packaging	Corrugated cardboard box with steel tool case	
Standard accessories	<ul style="list-style-type: none"> <li>• Hex. bar wrench (for M6) ..... 1</li> <li>• Hex. bar wrench (for M8) ..... 1</li> <li>• Steel tool case ..... 1</li> <li>• Side handle ..... 1</li> <li>• Bull point ..... 1</li> <li>• Oil feeder ..... 1</li> <li>• Wrench ..... 1</li> </ul>	

## 5-1. Optional Accessories

### 1. Demolition work

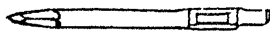

+

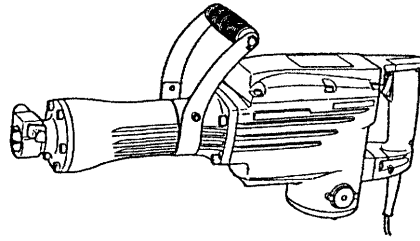

(1) Bull point

Overall length	Code No.
410 mm (16-9/64")	944961

### 2. Grooving and chiseling work

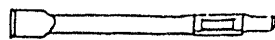

+

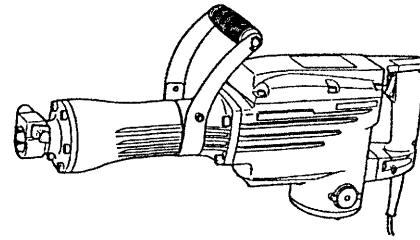

(1) Cold chisel

Overall length	Code No.
410 mm (16-9/64")	944962

### 3. Cutting and stripping work (asphalt cutting, etc.)



+

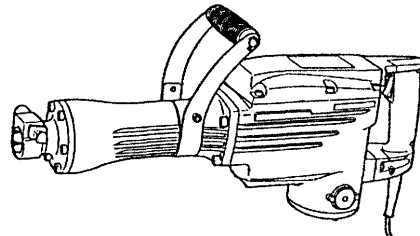

(1) Cutter

Width	Overall length	Code No.
75 mm (2-61/64")	410 mm (16-9/64")	944964

### 4. Digging (substitute pick-ax)

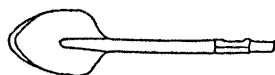

+

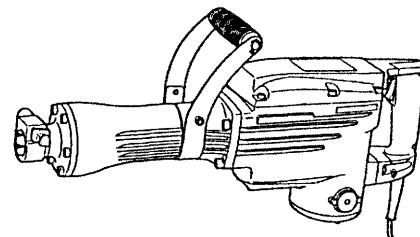

(1) Scoop

Overall length	Code No.
550 mm (21-21/32")	944967

5. Tamping work



(1) Rammer

Code No. 944965
Ext. Dia. 200 mm dia. (7-7/8")

+

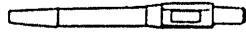

(2) Shank (SDS-max shank type)

Overall length	Code No.
250 mm (9-27/32")	944966

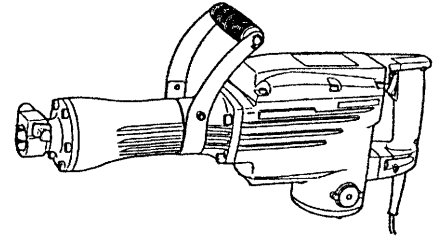

6. Electric hammer oil

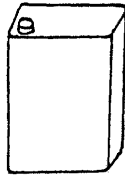

Capacity	Code No.
1 liter (0.26 gallon)	955009

(Note)

Code numbers listed above are subject to change. Please refer to periodic Technical News Bulletins.



## 6. COMPARISONS WITH SIMILAR PRODUCTS

### 6-1. Specification Comparisons

Maker		HITACHI		C-1	C-2
Model name		H 65SC	PH-65A		
Power input	W	1,240	1,240	1,300	1,430
Full-load impact rate	/min	1,400	1,400	1,450	1,300
Dimensions	Length	mm 647 (25-15/32")	642 (25-9/32")	675 (26-37/64")	647 (25-15/32")
	Height	mm 235 (9-1/4")	231 (9-3/32")	212 (8-11/32")	215 (8-15/32")
	Width	mm 120 (4-23/32")	120 (4-23/32")	120 (4-23/32")	— (—)
Striking energy per stroke	J	39.5	39.5	39.5	40.3
Insulation structure	—	Double insulation	Single insulation	Double insulation	Double insulation
No-load noise level	dB(A)	92	92	94	93
Weight (without cord)	kg	15.0 (33.1 lbs.)	15.0 (33.1 lbs.)	14.0 (30.9 lbs.)	17.0 (37.5 lbs.)

### 6-2. Demolition Performance Comparisons

The data shown in Fig. 1 are obtained in actual factory tests, and are for reference only. Demolished amount may vary in accordance with operating conditions, operator skill, etc.

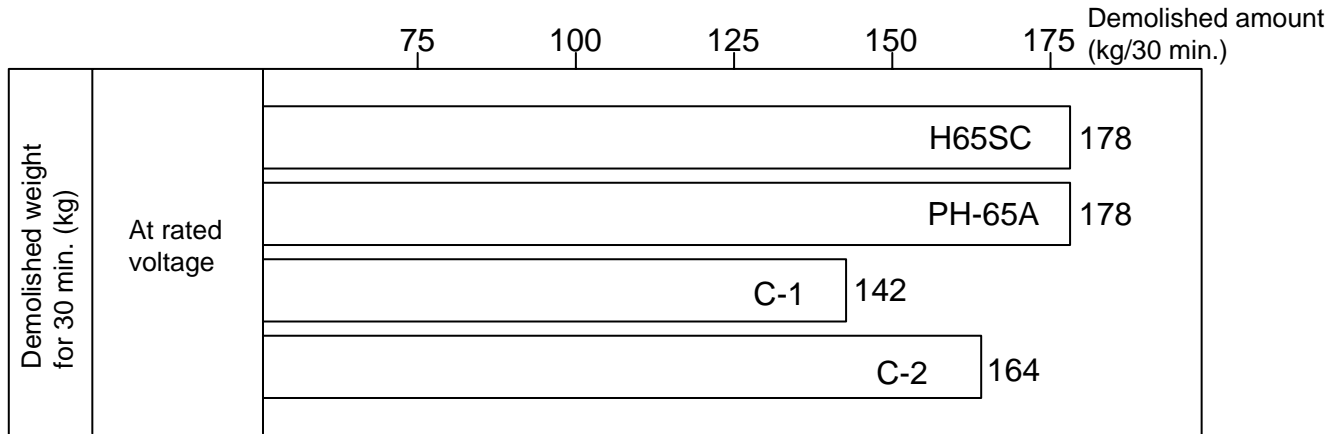

Fig. 1

## 7. PRECAUTIONS IN SALES PROMOTION

In the interest of promoting the safest and most efficient use of the Model H 65SC Electric Hammer by all of our customers, it is very important that at the time of sale the salesperson carefully ensures that the buyer seriously recognizes the importance of the contents of the Handling Instructions, and fully understands the meaning of the precautions listed on the Caution Plate attached to each tool.

### 7-1. Handling Instructions

Although every effort is made in each step of design, manufacture and inspection to provide protection against safety hazards, the dangers inherent in the use of any electric tool cannot be completely eliminated. Accordingly, general precautions and suggestions for the use of electric power tools, and specific precautions and suggestions for the use of the Electric Hammer are listed in the Handling Instructions to enhance the safe, efficient use of the tool by the customer. Salespersons must be thoroughly familiar with the contents of the Handling Instructions to be able to offer appropriate guidance to the customer during sales promotion.

### 7-2. Caution Plate

Each Model H 65SC unit is provided with a Caution Plate (illustrated below) which lists basic safety precautions in its use. Carefully ensure that the customer fully understands and follows these precautions before using the tool.

For the U.S.A. and Canada

#### **Hitachi Koki** MADE IN JAPAN

**- WARNING - • To reduce the risk of injury, user must read and understand instruction manual.**  
**AVERTISSEMENT • Afin de réduire le risque de blessures, l'utilisateur doit lire et bien comprendre le mode d'emploi.**

Cautions on Oil Gauge:

#### **OIL GAUGE CAP**

Feed oil, before oil is invisible in the oil gauge by holding the body upright.

If lubricant for high-speed rotating and sliding parts such as the needle bearings, piston, etc. is depleted, it could cause damage such as jamming of sliding parts, early damage, etc.

### 7-3. Oil Supply

As the Model H 65SC is equipped with a built-in oil tank, there is no need for manual oiling of the tool prior to and during operation.

To prevent possible oil staining of the steel carrying case during shipping, only approximately 10 cc of oil is supplied to the oil tank when the tool is shipped from the factory. Accordingly, it is very important that the customer be instructed to remove the Oil Gauge and fill the oil tank with the standard accessory oil at the time of purchase.

Instruct the customer to check the amount of oil periodically by holding the tool upright, as illustrated below, and observing the oil level in the Oil Gauge. When the oil level drops to a point approximately 3 mm (7/64") or less from the bottom of the Oil Gauge, remove the Oil Gauge and replenish the oil.

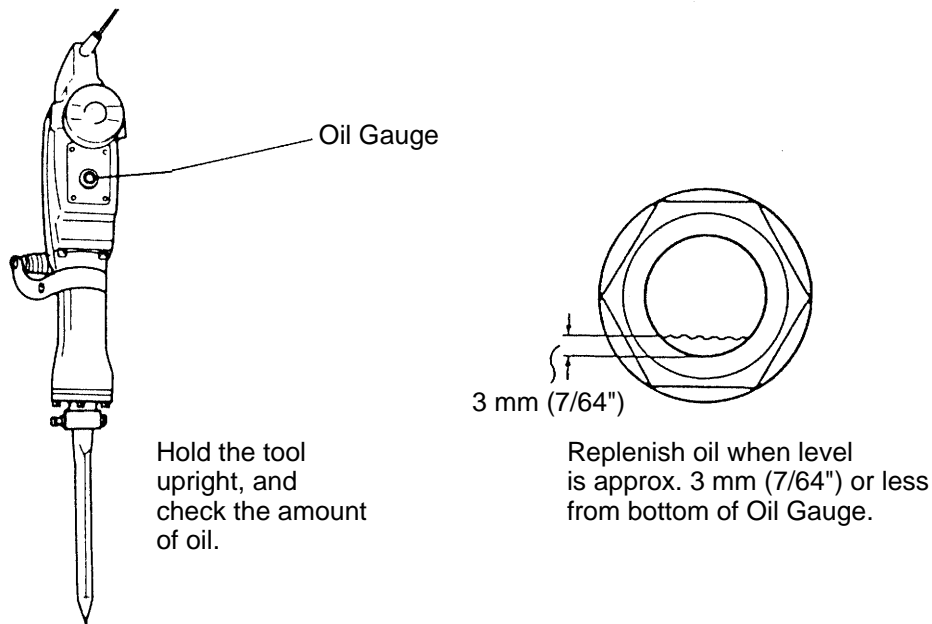

**Fig. 2**

Under average operating conditions, approximately 3 cc of oil will be consumed per hour of operation. The standard accessory oil feeder contains 120 cc of oil; when it is added to the oil tank, the oil tank will be filled with approximately 130 cc of oil. When it becomes necessary to replenish the oil, the customer should be cautioned to use Shell Omala Oil #150 without fail. To ensure that the appropriate oil is used, the customers should be urged to purchase and use the optional accessory Hitachi Electric Hammer Oil, Code No. 955009, which is available in one liter (0.26 gallon) containers.

#### **7-4. Impact Performance at Low Temperatures**

When starting the tool early in the morning when the ambient temperature is low or after the tool has not been used for a long period of time, oil viscosity may be very high and may cause improper or even complete lack of impact function even though the motor functions properly. In such a case, the customer should be instructed to continue no-load operation for approximately 5 minutes to allow the tool to warm up. The tool should then function normally.

## 8. REFERENCE INFORMATION

### 8-1. Structure of the Main Body

The primary structure of the Model H 65SC is similar with the Model PH-65A, as illustrated. (Fig. 3)

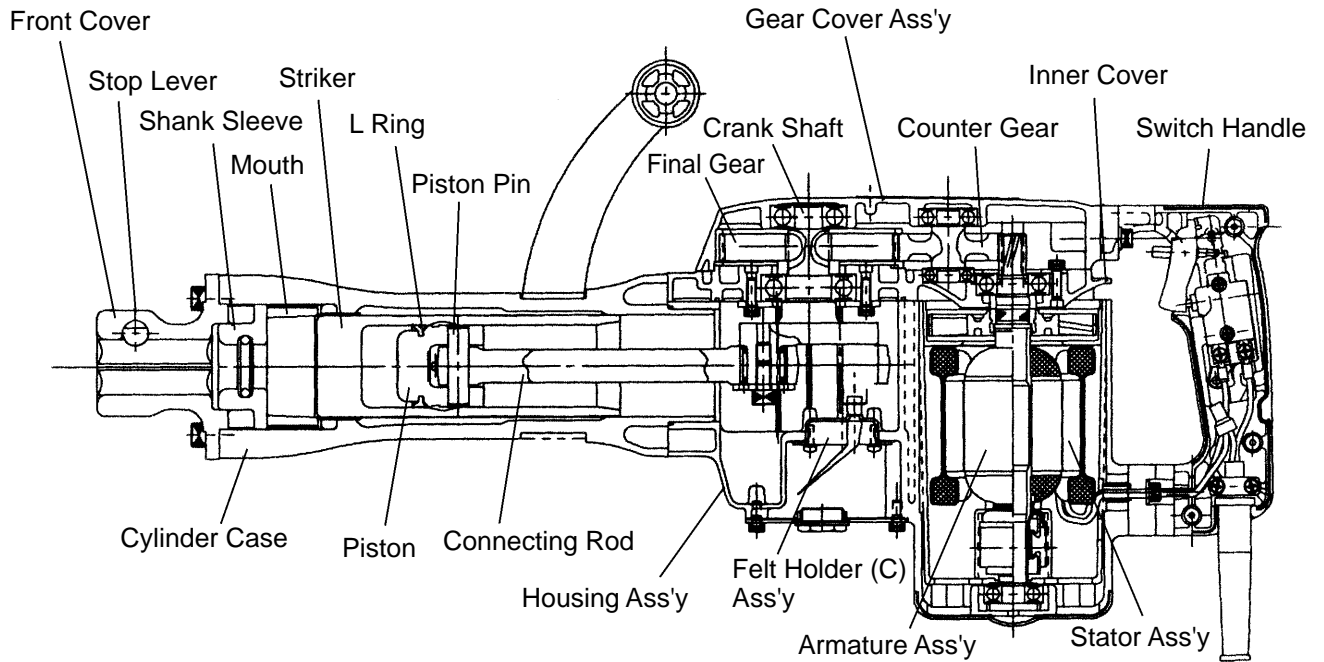

Fig. 3

### 8-2. Stop Lever [Tool Retainer] (Fig. 4 and Fig. 5)

- (1) Clean, then smear the tool shank with grease or machine oil. (Fig. 4)
- (2) Rotate the stop lever 180° in a clockwise direction while pulling it toward you. Next, insert the tool shank into the hexagonal hole on the front cover. (Fig. 4)
- (3) Clamp the tool by turning the stop lever by half a turn in the opposite direction. (Fig. 5)

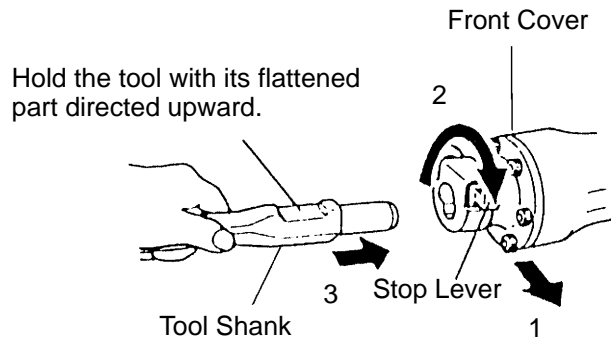

Fig. 4

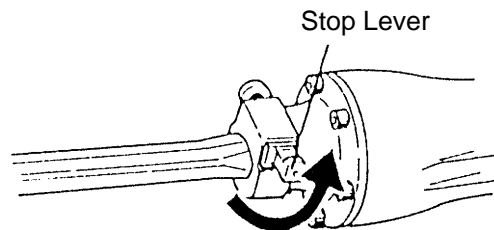

Fig. 5

### 8-3. Movement of the Stop Lever

After an extended period of use, the operation of the Stop Lever may become difficult due to incursion of concrete powder or similar materials into its sliding portion. In such a case, apply oil into the sliding portion between the Stop Lever and fitting portion of the Front Cover.

### 8-4. No-load Striking Preventive Mechanism

This machine is so constructed that when the bit end is lifted off the surface being worked, the striker is caught in the mouth to prevent no-load striking; and when the striker comes off the mouth, a phase difference between the piston and striker is utilized to reduce the striker's amplitude, thereby preventing the striker from striking the bit as a double-preventive measure against no-load striking. When the striker is prevented from striking the bit, turn the switch OFF; then the switch ON again with the bit lightly push the main body on the concrete surface so that the equipment starts striking.

## 9. REPAIR GUIDE

### 9-1. Precautions and Suggestions for Disassembly and Reassembly of the Main Body

The **[Bold]** numbers in the descriptions below correspond to the item numbers in the Parts List and exploded assembly diagram.

#### 9-1-1. Disassembly

[NOTE] If it is difficult to loosen and remove the fixing bolts, use an appropriate heat gun, etc. to heat them to approximately 80 °C (176 °F).

- Disassembly of the Armature Ass'y **[61]**

- (1) Loosen the four Seal Lock Hex. Socket Hd. Bolts M4 x 12 **[70]**, remove the Cap Covers **[65]**, Cap Rubbers **[66]** and Brush Caps **[67]**, and take out the Carbon Brushes **[68]**. At this time, be very careful not to lose the disassembled parts.
- (2) Loosen the four Nylock Hex. Socket Hd. Bolts M8 x 35 **[22]**, and remove the Cylinder Case **[20]**. Next, after loosening the Seal Lock Hex. Socket Hd. Bolt M8 x 16 **[35]**, the Connecting Rod Ass'y **[38]** and Crank Washer **[39]** can be disassembled. Leave the Striker **[8]** and Piston **[11]** as they are.
- (3) Loosen the four Seal Lock Hex. Socket Hd. Bolts M6 x 25 **[101]**, and take off the Handle and Handle Cover Set **[88]**. Next, loosen the six Seal Lock Hex. Socket Hd. Bolts M6 x 45 **[47]**, and disassemble the Gear Cover **[40]** and Counter Gear **[52]**. Then, by inserting a flat-blade screwdriver or similar tool into one of the air vents of the Inner Cover **[45]** and lifting it upwards, the Inner Cover **[45]**, Armature Ass'y **[61]**, Crank Shaft **[37]**, and related parts can be removed in a single body.
- (4) As illustrated in Fig. 6, support the Inner Cover **[45]** with an appropriate tubular jig, and push down on the end surface of the armature shaft with a hand press to separate the Armature Ass'y **[61]** from the Inner Cover **[45]**.

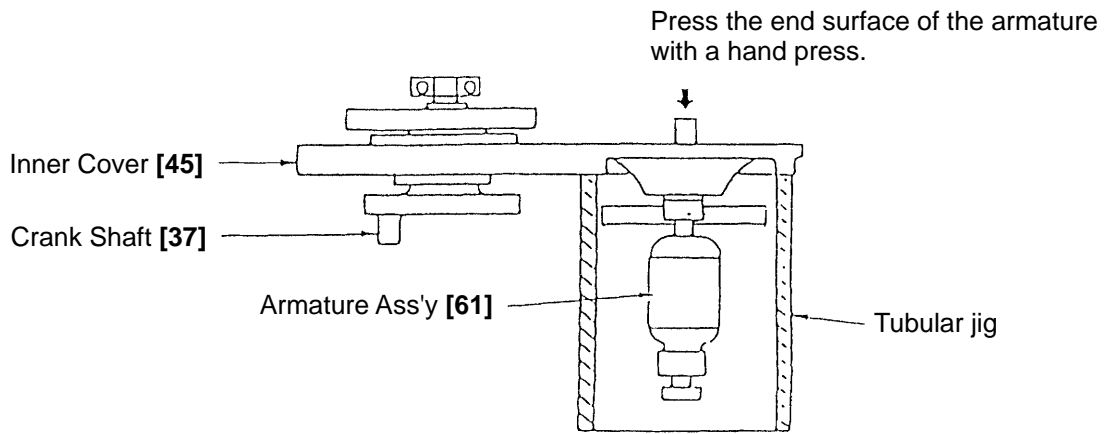

Fig. 6

- Disassembly of the Crank Shaft [37] section

First, remove the four Seal Lock Hex. Socket Hd. Bolts M5 x 16 [33] which fix the Bearing Cover [32]. Then, as illustrated in Fig. 7, support the lower surface of the Inner Cover [45] with an appropriate tubular jig, align an appropriate steel rod with the end surface of the Crank Shaft [37], and press down on the steel rod with a hand press. The Ball Bearing 6205DDCMPS2L [31], Distance Ring (B) [43], Final Gear [42], two Woodruff Keys 4 x 16 [36], and Crank Shaft [37] can then be disassembled from the Inner Cover [45].

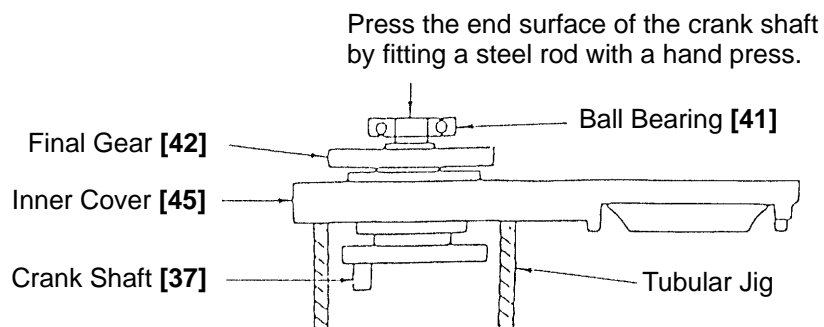

Fig. 7

- Disassembly of remaining parts from the Inner Cover [45]

Loosen the three Seal Lock Hex. Socket Hd. Bolts M5 x 16 [33], and take out Bearing Cover (A) [48] and the Ball Bearing 6203DDCMPS2L [49].

- Disassembly of the Mouth [17] and related parts

First, remove the six Nylock Hex. Socket Hd. Bolts M8 x 30 [3], and separate the Front Cover [7] from the Cylinder Case [20]. The Shank Sleeve [15], Damper [13], Mouth [17], Mouth Cover [16], Mouth Washer [18], and Urethane Ring [19] can then be taken out.

- Removal of the O-Ring [14]

As the O-Ring [14] is installed in the inner portion of the Shank Sleeve [15], it may be difficult to remove. As illustrated in Fig. 8, pry the O-Ring [14] upward gently with a slender flat-blade screwdriver, being very careful not to damage the surface of the O-Ring.

- Removal of the Striker [8] and related parts

Remove the four Nylock Hex. Socket Hd. Bolts M8 x 35 [22], and separate the Cylinder Case [20] from the Housing Ass'y [59]. From the Cylinder Case [20], take out the Striker [8], Piston [11], and Connecting Rod Ass'y [38] in a single body. Holding the Striker [8] firmly in one hand, grasp the Connecting Rod Ass'y [38] in the other hand and pull it forcefully to separate it from the Striker. Finally, extract the Piston Pin [10] from the Piston [11], and separate the Piston from the Connecting Rod Ass'y [38].

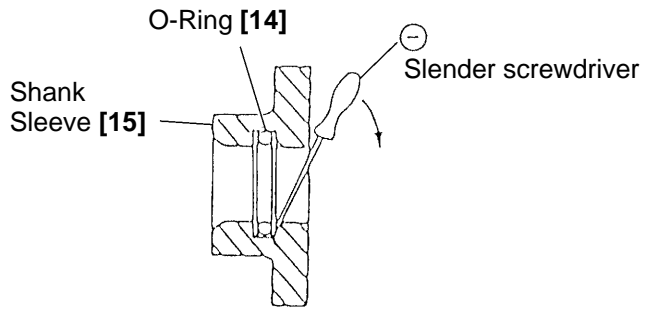

Fig. 8

- Disassembly of the Stop Lever [1]

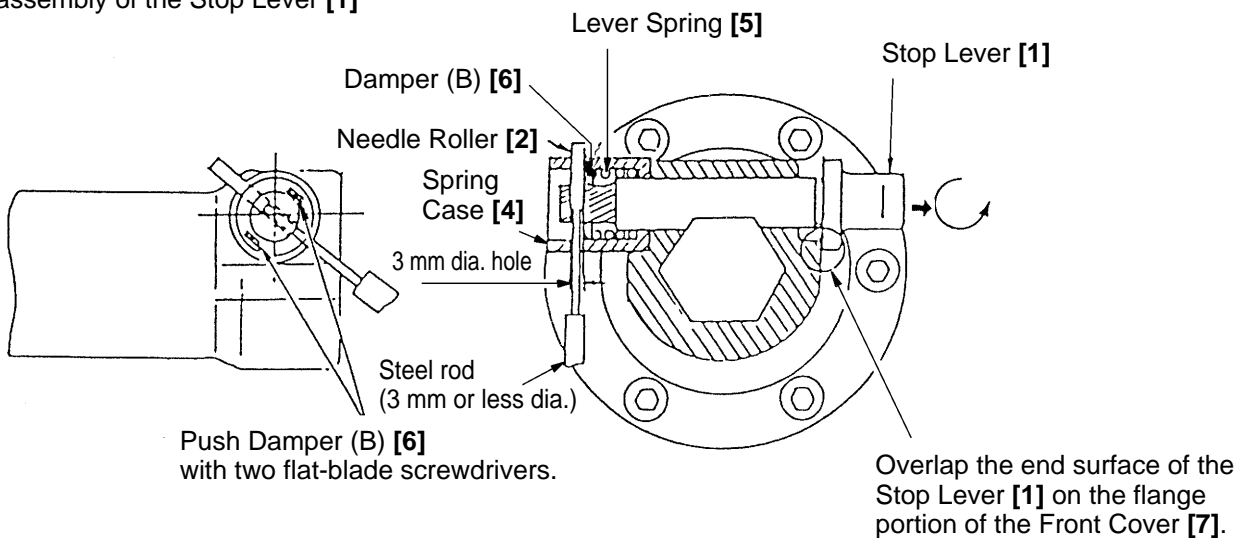

Fig. 9

Disassembly procedures are illustrated in Fig. 9. Pull the Stop Lever [1] outward in the direction indicated by the arrow, and turn it slightly so that its end surface comes to rest on the flange portion of the Front Cover [7]. Next, turn the Spring Case [4] so that the holes of the Spring Case are aligned with the Needle Roller [2]. Then, push in Damper (B) [6] with flat-blade screwdrivers to compress the Lever Spring [5]. Finally, while keeping the Lever Spring compressed, fit a 3 mm or less dia. steel rod into the hole of the Spring Case [4], and push out the Needle Roller [2]. The Stop Lever [1], the Damper (B) [6], and the Lever Spring [5] can then be taken out.

- How to remove the L-Ring [9]

The L-Ring [9] can be removed by prying it with a flat-blade screwdriver or manually, as shown in the following figure. (Fig. 10)

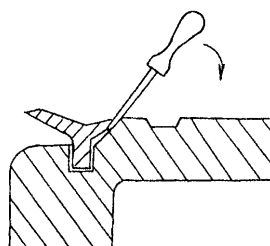

Fig. 10

## 9-1-2. Reassembly

Reassembly can be accomplished by following the disassembly procedures in reverse. However, special attention should be given to the following items.

### (1) Reassembly of the Crank Shaft [37] section:

Press-fit the Ball Bearing 6205DDCMPS2L [31] into the Inner Cover [45], and fasten Bearing Cover [32] onto the Inner Cover [45] with the four Seal Lock Hex. Socket Hd. Bolts M5 x 16 [33]. Support the inner race of the Ball Bearing 6205DDCMPS2L [31] with an appropriate jig, and press-fit the Crank Shaft [37] into the Ball Bearing. Next, insert Distance Ring (B) [43] and two Woodruff Keys 4 x 16 [36] into the Crank Shaft [37], and press-fit the Final Gear [42] and the Ball Bearing 6302VVCMP2L [41] with a hand press.

### (2) Reassembly of the Armature Ass'y [61]:

Press-fit the Ball Bearing 6203DDCMPS2L [49] into the Inner Cover [45], and fasten Bearing Cover (A) [48] onto the Inner Cover with the three Seal Lock Hex. Socket Hd. Bolts M5 x 16 [33].

### (3) Reassembly of the Striker [8]: (Two possible methods) (Fig. 11)

A. After the Connecting Rod Ass'y [38] has been assembled into the Housing Ass'y [59], mount the Piston [11] and press it into the Striker [8].

B. Mount the Piston [11] onto the Connecting Rod Ass'y [38], and push down on the Connecting Rod Ass'y to press the Piston into the Striker [8].

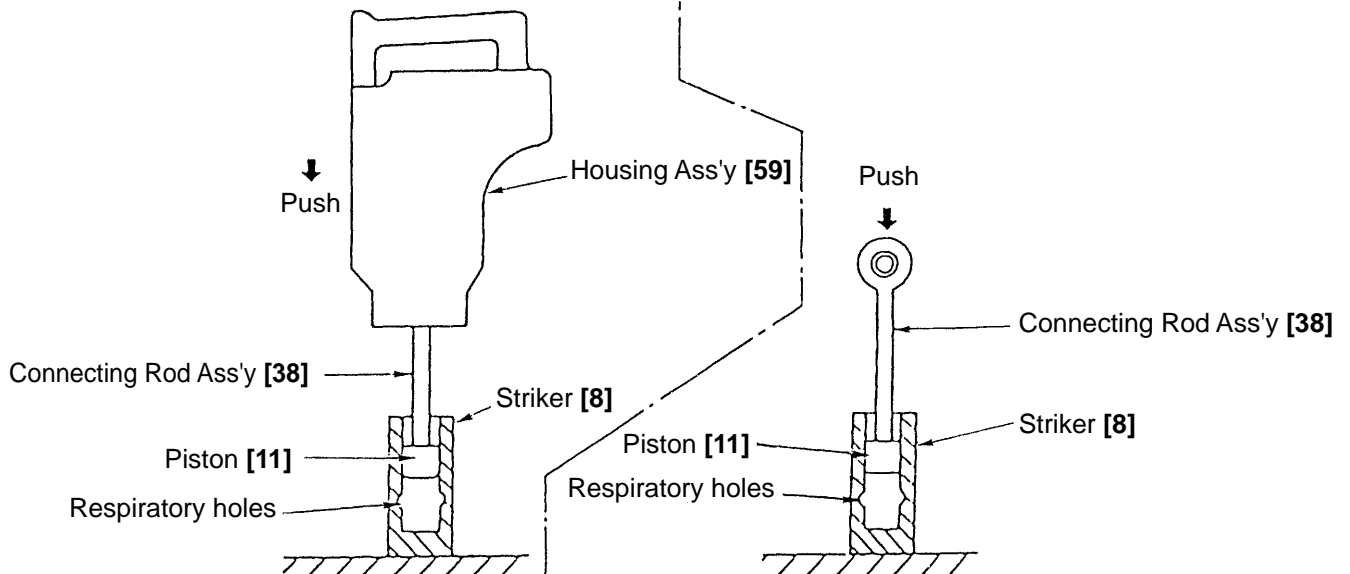

Fig. 11

Either of the two methods described above requires a pressing force of more than 30 kg. When a "hissing" sound is heard, the Piston is properly inserted in the Striker. (The "hissing" is the sound of the compressed air escaping from the Striker when the Piston reaches the respiratory chambers within the Striker.)



(4) Reassembly of the Oil Felt:

To replace the Oil Felt [79], follow the procedures described below.

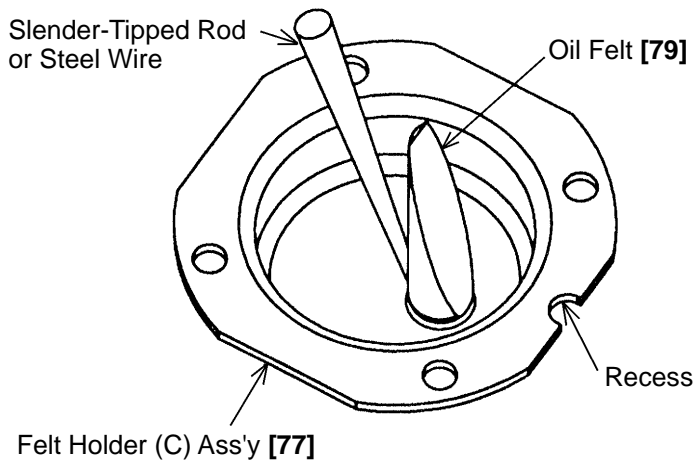

Fig. 12

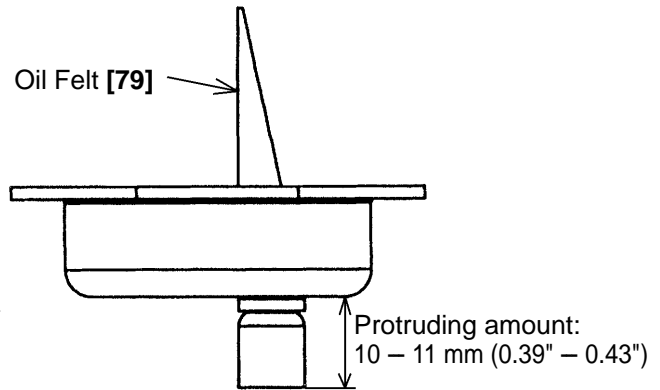
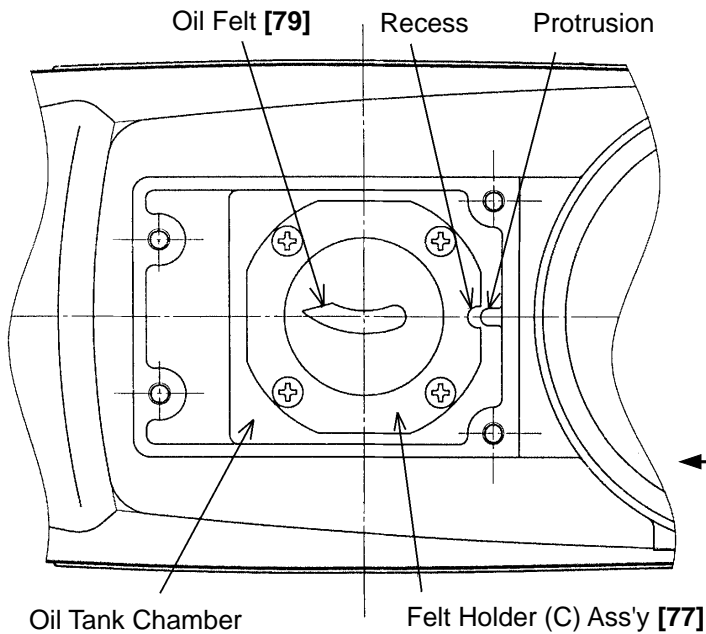
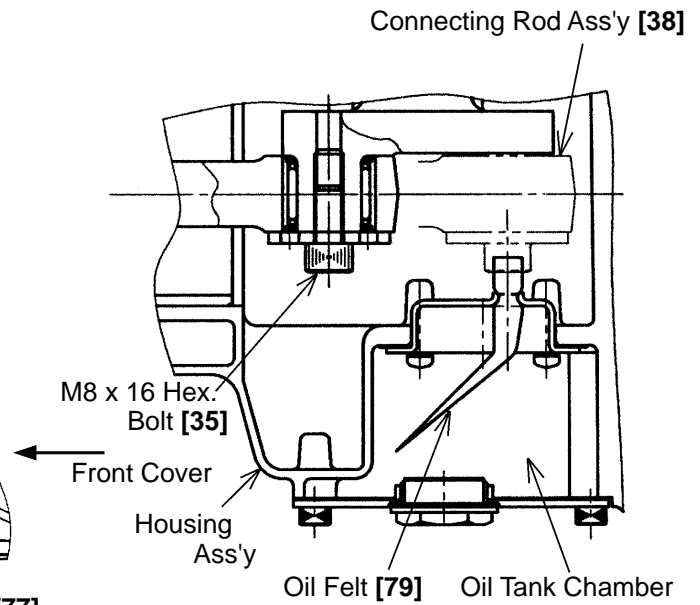

Fig. 13

- 1) As illustrated in Fig. 12, fit the wide end of the Oil Felt [79] into the oiling hole, and push it through with a slender-tipped rod or steel wire.
- 2) When approximately 5 mm (0.2") of the Oil Felt [79] has been pushed through into the oil tank, grasp the tip with pliers or a similar tool, and pull it into the oil tank so that 10 – 11 mm (0.39" – 0.43") remains protruding into the crank case chamber side, as illustrated in Figs. 12 and 13.
- 3) As illustrated in Fig. 14, mount the Felt Holder (C) Ass'y [77] so that its recess is engaged with the protrusion on the inside of the oil tank chamber of the housing.
- 4) Assemble the Connecting Rod Ass'y [38] onto the Crank Shaft [37], rotate the Crank Shaft by hand, and confirm that the Oil Felt [79] comes into contact with the Seal Lock Hex. Socket Hd. Bolt M8 x 16 [35] which fixes the Connecting Rod Ass'y [38]. (Fig. 15)
- 5) After mounting the Felt Holder (C) Ass'y [77], the Oil Felt [79] must be bent toward the Front Cover [7] side as illustrated in Fig. 15.



**Fig. 14**



**Fig. 15**

(5) How to install Seal Ring (A) [44]:

To prevent oil from leaking through between the Housing Ass'y [59] and the Inner Cover [45], Seal Ring (A) [44] is installed in the Inner Cover [45] for sealing oil. When fitting Seal Ring (A) [44] in the ring groove on the Inner Cover [45], exercise care not to allow the Seal Ring to twist or project out of the groove.

(6) How to install the L-Ring [9]:

When installing the L-Ring [9] on the Piston [11], pay attention to the L-Ring direction. The longer flange side should be directed to the front, as shown in the figure. (Fig. 16)

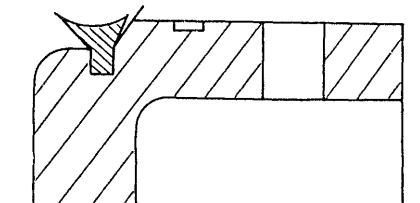

**Fig. 16**

(7) Cover Plate [72]:

Any gap between the Cover Plate [72] and the Housing Ass'y [59] may result in oil leakage or failure of automatic lubrication. Do not disassemble the Cover Plate [72] except when absolutely necessary. When it is inevitably necessary to disassemble and reassemble the Cover Plate (as when replacing the Oil Felt [79]), for thorough sealing, apply liquid packing (Fuji Oil Sheet No. 600K) to the mounting surface on the Housing Ass'y [59].

### 9-1-3. Screw Locking Agent TB1401

(1) Prior to reassembly, all M5, M6, Hexagon Socket Hd. Bolts and Machine Screws must be coated with Screw Locking Agent ThreeBond TB1401.

(2) The following parts must be replaced with Hitachi Genuine Parts once they are loosened.

- Front Cover Fixing Bolts: M8 x 30 [3]
- Cylinder Case Fixing Bolts: M8 x 35 [22]
- Fixing Bolt on the Connecting Rod Ass'y [38] M8 x 16 [35]

**(CAUTION)** If fastening bolts come loose from vibration, it could cause serious damage to the machine. Ensure without fail that TB1401 Screw Locking Agent is applied as directed above prior to reassembly.

Before applying the TB1401, carefully clean any grease or other foreign matter from the male and female threads with gasoline, thinner or similar cleaning solvents.

### 9-1-4. Tightening Torque

- |                                 |  |
|---------------------------------|--|
| (1) M4 Hexagon Socket Hd. Bolts | $4.41^{±0.49}$ N•m ( $45^{±5}$ kgf•cm, $39.1^{±4.3}$ in-lbs.)          |
| (2) M5 Hexagon Socket Hd. Bolts | $7.84^{+1.96}_0$ N•m ( $80^{+20}_0$ kgf•cm, $69.5^{+12.4}_0$ in-lbs.)  |
| (3) M6 Hexagon Socket Hd. Bolts | $9.80^{+1.96}_0$ N•m ( $100^{+20}_0$ kgf•cm, $86.9^{+17.4}_0$ in-lbs.) |
| (4) M8 Hexagon Socket Hd. Bolts | $29.4^{+1.96}_0$ N•m ( $300^{+20}_0$ kgf•cm, $260^{+17.4}_0$ in-lbs.)  |
| (5) D4 Tapping Screw            | $1.96^{±0.49}$ N•m ( $20^{±5}$ kgf•cm, $17.4^{+4.3}_0$ in-lbs.)        |

[NOTE] If above bolts are tightened more than the designated values, it may cause breakage. Without fail, tighten the Bolts and Screws according to the above specified values.

### 9-1-5. Internal Wiring

- Wiring diagram of products with noise suppressor (Fig. 17)

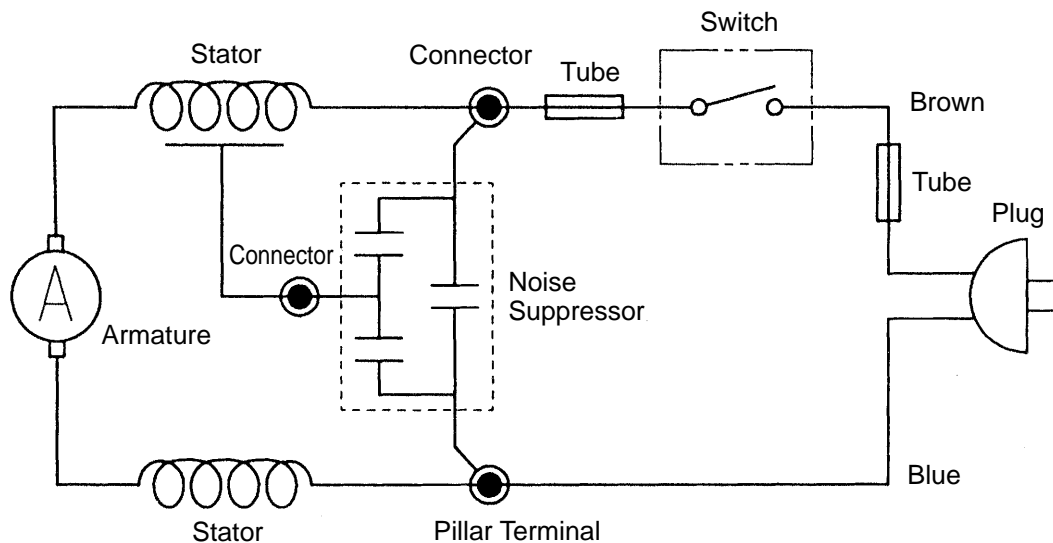

Fig. 17

Wiring diagram of products without noise suppressor (Fig. 18)

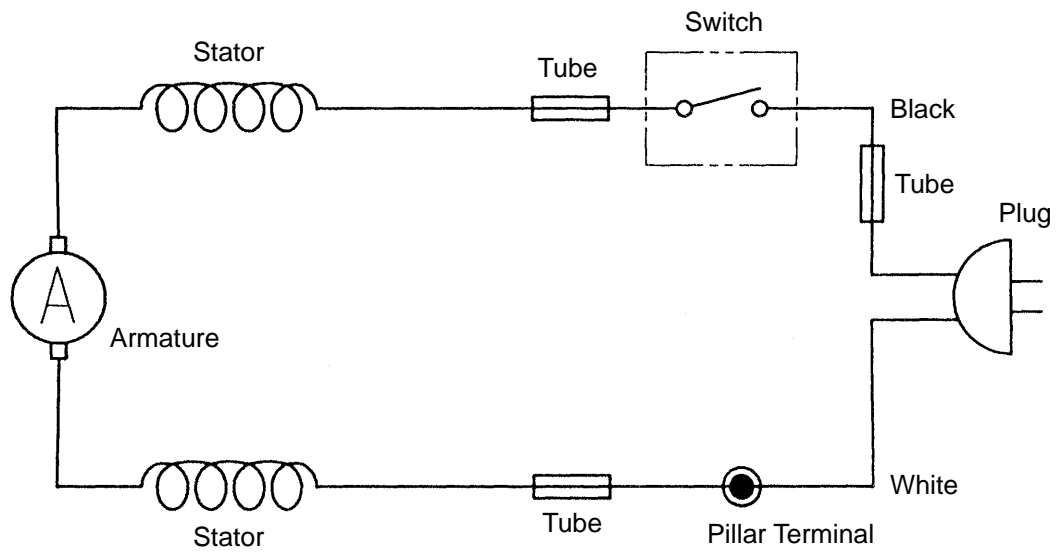

Fig. 18

#### 9-1-6. Insulation Tests

On completion of disassembly and repair, measure the insulation resistance and dielectric strength.

Insulation resistance: 7 M $\Omega$  or more with DC 500 V Megohm Tester.

Dielectric strength: AC 4000 V/1 minute, with no abnormalities ... 220 V – 240 V

(and 110 V for U.K. products)

AC 2500 V/1 minute, with no abnormalities ... 110 V – 127 V

(except U.K. products)

#### 9-1-7. No-Load Current Value

After no-load operation for 30 minutes, the no-load current value should be as follows:

Voltage (V)	110	115	220	230	240
Current (A) (Max.)	5.9	5.7	3.0	2.8	2.7

### 10. STANDARD REPAIR TIME (UNIT) SCHEDULES

MODEL	Variable		20	40	60	80	100	120 min.
	Fixed							
H 65SC		Work Flow						
		Switch Cord Ass'y	→					Housing Stator Ass'y
	General Assembly			Handle		Gear Cover	Armature Ass'y	
	Fixed Cost							
	Switch	} 0 min.						
	Handle							
	Front Cover							
	Lever		Front Cover Lever	Mouth Mouth Cover Urethane Ring Shank Sleeve Damper	Cylinder Case Ass'y			Ball Bearing (6201) Ball Bearing (6203)
	Cord Ass'y	10 min.						
	Others	20 min.						Counter Gear Ball Bearing (6001) Ball Bearing (6201)
			Striker Piston L-Ring Connecting Rod Ass'y Needle Bearing				Ball Bearing (6302) Final Gear Crank Shaft Ball Bearing (6205) Inner Cover	

# Assembly Diagram for H 65SC

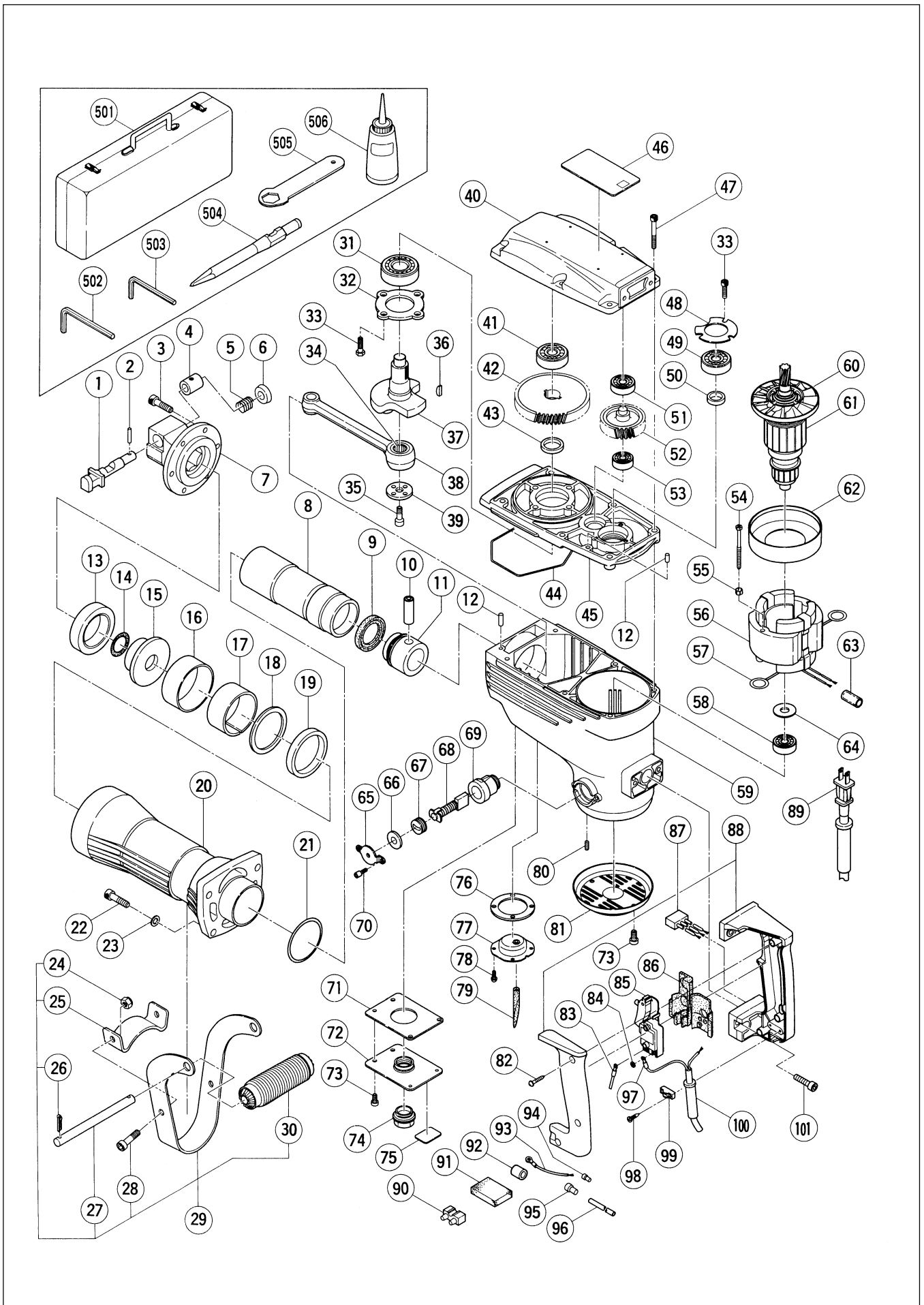

## PARTS

H 65SC

ITEM NO.	CODE NO.	DESCRIPTION	NO. USED	REMARKS
1	998-423	STOP LEVER	1	
2	998-426	NEEDLE ROLLER	1	
3	306-437	NYLOCK HEX. SOCKET HD. BOLT M8X30	6	
4	998-424	SPRING CASE	1	
5	956-975	LEVER SPRING	1	
6	998-425	DAMPER (B)	1	
7	957-152	FRONT COVER	1	
8	956-958	STRIKER	1	
9	944-927	L-RING	1	
10	944-928	PISTON PIN	1	
11	956-957	PISTON	1	
12	944-918	PIN D5X15.8	2	
13	956-965	DAMPER	1	
14	944-936	O-RING	1	
15	956-964	SHANK SLEEVE	1	
16	956-962	MOUTH COVER	1	
17	956-963	MOUTH	1	
18	956-961	MOUTH WASHER	1	
19	956-960	URETHANE RING	1	
20	306-164	CYLINDER CASE (BLACK)	1	
21	956-996	O-RING (1AS-60)	1	
22	306-163	NYLOCK HEX. SOCKET HD. BOLT M8X35	4	
23	949-433	BOLT WASHER M8 (10 PCS.)	4	
24	944-950	U-NUT (B) M8	2	
25	944-948	HANDLE STAY	1	
26	949-895	SPLIT PIN D4X25 (10 PCS.)	2	
27	944-952	HANDLE SHAFT	1	
28	949-655	HEX. SOCKET HD. BOLT M8X16 (10 PCS.)	2	
29	956-852	SIDE HANDLE ASS'Y	1	INCLUD.24-28,30
30	944-951	GRIP	1	
31	620-5DD	BALL BEARING 6205DDCMPS2L	1	
32	956-949	BEARING COVER	1	
33	990-079	SEAL LOCK HEX. SOCKET HD. BOLT M5X16	7	
34	944-921	NEEDLE BEARING (NTN 8E-NK 18/20 RDO)	1	
35	996-364	SEAL LOCK HEX. SOCKET HD. BOLT M8X16	1	
36	956-850	WOODRUFF KEY 4X16	2	
37	957-142	CRANK SHAFT	1	
38	998-434	CONNECTING ROD ASS'Y	1	INCLUD.34
39	956-955	CRANK WASHER	1	
40	318-207	GEAR COVER	1	
41	630-2VV	BALL BEARING 6302VVCMPMS2L	1	
42	944-916	FINAL GEAR	1	
43	944-915	DISTANCE RING (B)	1	
44	957-143	SEAL RING (A)	1	
45	998-412	INNER COVER	1	
46		NAME PLATE	1	
47	986-940	SEAL LOCK HEX. SOCKET HD. BOLT M6X45	6	
48	944-911	BEARING COVER (A)	1	
49	620-3DD	BALL BEARING 6203DDCMPS2L	1	
50	944-907	DISTANCE RING (A)	1	
51	620-1VV	BALL BEARING 6201VVCMPMS2L	1	

## PARTS

H 65SC

ITEM NO.	CODE NO.	DESCRIPTION	NO. USED	REMARKS
52	956-948	COUNTER GEAR	1	
53	600-1VV	BALL BEARING 6001VVCMP2L	1	
54	960-251	HEX. HD. TAPPING SCREW D5X65	2	
55	956-764	SPECIAL WASHER	2	
* 56	340-259G	STATOR ASS'Y 115V	1	INCLUD.57,63 FOR USA
* 56	340-259E	STATOR ASS'Y 220V-230V	1	INCLUD.57,63
57	945-932	BRUSH TERMINAL	2	
58	620-1DD	BALL BEARING 6201DDCMP2L	1	
59	318-208	HOUSING ASS'Y	1	INCLUD.69,80
60	996-370	FAN	1	
* 61	360-286U	ARMATURE ASS'Y 115V	1	INCLUD.49,58,60,64 FOR USA
* 61	360-286E	ARMATURE ASS'Y 220V-230V	1	INCLUD.60
62	306-098	FAN GUIDE	1	
63		VINYL TUBE(ID7XT0.25X20)	1	
64	944-954	BEARING WASHER	1	
65	956-972	CAP COVER	2	
66	944-960	CAP RUBBER	2	
67	940-540	BRUSH CAP	2	
68	999-086	CARBON BRUSH (AUTO STOP TYPE) (1 PAIR)	2	
69	956-984	BRUSH HOLDER	2	
70	983-162	SEAL LOCK HEX. SOCKET HD. BOLT M4X12	4	
71	956-971	COVER SEAL	1	
72	956-970	COVER PLATE	1	
73	991-690	SEAL LOCK HEX. SOCKET HD. BOLT M5X12	6	
74	955-011	OIL GAUGE	1	
75		CAUTION PLATE	1	
76	956-969	HOLDER SEAL	1	
77	318-206	FELT HOLDER (C) ASS'Y	1	INCLUD.79
78	987-203	SEAL LOCK SCREW (W/SP. WASHER) M4X12	4	
79	998-534	OIL FELT	1	
80	938-477	HEX. SOCKET SET SCREW M5X8	2	
81	306-099	TAIL COVER	1	
82	307-028	TAPPING SCREW (W/FLANGE) D4X25 (BLACK)	3	
* 83	981-974	INTERNAL WIRE	1	EXCEPT USA
* 84	949-423	WASHER M4 (10 PCS.)	1	FOR SAF,HOL
85	995-398	SWITCH (A) (1P SCREW TYPE) W/LOCK	1	
86	312-408	SUPPORT (F)	1	
* 87	994-273	NOISE SUPPRESSOR	1	EXCEPT HKG,USA
88	971-168	HANDLE AND HANDLE COVER SET	1	
* 89	500-440Z	CORD	1	(CORD ARMOR D8.2) FOR HKG
* 89	500-454Z	CORD	1	(CORD ARMOR D10.7) FOR SAF
* 89	500-390Z	CORD	1	(CORD ARMOR D10.7) FOR HOL
* 89	500-434Z	CORD	1	(CORD ARMOR D8.2) FOR USA
* 89	500-457Z	CORD	1	(CORD ARMOR D8.2) FOR CHN
* 90	938-307	PILLAR TERMINAL	1	FOR USA
* 91	963-243	SUPPORT	1	FOR USA
92	306-167	TUBE (I.D.7XT1.1X15)	1	
* 93	305-798	INTERNAL WIRE	1	EXCEPT HKG,USA
* 94	959-140	CONNECTOR 50091 (10 PCS.)	1	EXCEPT HKG,USA
* 95	959-141	CONNECTOR 50092 (10 PCS.)	1	EXCEPT USA
* 96	996-438	VINYL TUBE (A) (I.D.7XT0.5X50)	2	

\* : ALTERNATIVE PARTS

8 - 99



**PARTS**

H 65SC

ITEM NO.	CODE NO.	DESCRIPTION	NO. USED	REMARKS
*	96	996-438	VINYL TUBE (A) (I.D.7XT0.5X50)	3 FOR USA
*	97	980-063	TERMINAL	1
*	97	992-810	TERMINAL	1 FOR HOL
*	97	930-804	TERMINAL M4.0 (10 PCS.)	1 FOR USA
	98	984-750	TAPPING SCREW (W/FLANGE) D4X16	2
	99	960-266	CORD CLIP	1
*	100	940-778	CORD ARMOR D10.7	1
*	100	958-049	CORD ARMOR D8.2	1
	101	987-707	SEAL LOCK HEX. SOCKET HD. BOLT M6X25	4

**STANDARD ACCESSORIES**

ITEM NO.	CODE NO.	DESCRIPTION	NO. USED	REMARKS
	501	314-170	CASE (STEEL)	1
	502	872-422	HEX. BAR WRENCH 6MM	1
	503	944-459	HEX. BAR WRENCH 5MM	1
	504	944-961	BULL POINT 410MM	1
	505	971-109	WRENCH 23MM	1
	506	931-848	LUBRICANT OILER (120CC)	1

**OPTIONAL ACCESSORIES**

ITEM NO.	CODE NO.	DESCRIPTION	NO. USED	REMARKS
	601	944-962	COLD CHISEL 410MM (HEX. SHANK TYPE)	1
	602	944-964	CUTTER W75X45L (ROUND SHANK TYPE)	1
	603	944-966	RAMMER SHANK (HAMMER)	1
	604	944-965	RAMMER 200MM	1
	605	957-154	SCOOP 380L (ROUND SHANK TYPE)	1