



Service Manual

FOR THE TURBOCHEF FIRE OVEN

CAUTION: Read the instructions before using the machine.

©2014-2015 TurboChef Technologies, Inc.



For further information, call

800.90TURBO

or

+1 214.379.6000

Original Instructions

The information contained in this manual is important for the proper installation, use, maintenance, and repair of this oven. Follow these procedures and instructions to help ensure satisfactory baking results and years of trouble-free service.

Errors – descriptive, typographic, or pictorial – are subject to correction. Specifications are subject to change without notice.

Please carefully read this manual and retain it for future reference.

Table of Contents

Important Safety Instructions

General Safety Information	i
Reducing Fire Risk	ii
Grounding Instructions	ii
Power Cord Replacement or Removal	ii
Protective Earth (Ground) Symbol	ii
Equipotential Bonding Symbol	ii

Specifications and Installation

Performance	1
Dimensions	1
Certifications	2
Oven Construction	2
Electrical Specifications	2
Installation	2
Unpacking Instructions	2
Installation Warnings - Read Before Lifting Oven	2
Lifting and Placing the Oven	2
Installation Near Open Heat Source	3
Voltage Selection	3
Ventilation	3
Installing the Oven Handle	4

Daily Maintenance

5

Oven Operation

Oven Controls	7
Cooking	7
Setting the Temperatures	8
Setting the Timers	8
Setting the Parameters	8
Front Panel Light Indicators	10

Troubleshooting

Fault Code Er1	11
Fault Code Er2	11
Fault Code Ht	12
Oven Not Heating	12
Food Not Cooking Properly	13

Oven Schematics

15

Appendix - Replacing Oven Components

Replacing Oven Components

A-1

Replacing Items

A-2

IMPORTANT SAFETY INSTRUCTIONS



WARNING: When operating this oven, strictly adhere to the following safety precautions to reduce the risk of burns, electric shock, fire, injury, or damage to oven or property near oven.



WARNING: This appliance has hot surfaces! During use, the accessible parts of the oven can get very hot. When opening the oven door, during, or after cooking, pay careful attention to the flow of hot air and any steam that may be released from the cooking chamber. Move to the side or step back.

General Safety Information

- ✓ To ensure proper use of the appliance, read all parts of this manual carefully and store safely. Before using the appliance, clean all surfaces that will be coming into contact with food.
- ✓ Read all instructions before using this appliance.
- ✓ This appliance must be grounded. Connect only to a properly grounded outlet. See "Grounding Instructions" on page ii.
- ✓ Install or locate this appliance only in accordance with the provided installation instructions.
- ✓ This appliance should be serviced by qualified service personnel only. Contact the nearest authorized service facility for examination, repair, or adjustment.
- ✓ Keep the cord away from heated surfaces.
- ✓ Use this appliance only for its intended uses as described in this manual.
- ✓ This appliance is designed for professional use. Only allow qualified or duly instructed personnel to use. Always monitor the appliance during operation.
- ✓ In the event of a failure, breakage or irregular function, switch the appliance off and disconnect the oven from the power supply.
- ✓ Always ensure the oven is disconnected from the power supply before servicing, repairing, or adjusting any components or parts.
- x DO NOT use corrosive chemicals or vapors in this appliance; it is not designed for industrial/laboratory use.
- x **WARNING:** DO NOT heat liquids or other foods in sealed containers (e.g., jars, whole eggs, etc.) since they are liable to explode.
- x DO NOT allow children to use this appliance.
- x DO NOT operate this appliance if it has a damaged cord or plug, is not working properly, has been damaged or dropped. See "Power Cord Replacement or Removal" found on page ii.
- x DO NOT cover or block any openings on this appliance.
- x DO NOT store this appliance outdoors.
- x DO NOT use this appliance near water (e.g., near a kitchen sink, in a wet basement, near a swimming pool).
- x DO NOT immerse the cord or plug in water.
- x DO NOT let the cord hang over the edge of a table or counter.
- x DO NOT place the cord near heated surfaces.
- x DO NOT store or use flammable vapors or liquids (e.g., gasoline) in the vicinity of this appliance.
- x DO NOT use a water jet for cleaning. See page 5 in this manual for proper cleaning procedures.
- x This appliance is not to be used by children or persons with reduced physical, sensory or mental capabilities, or lack of experience and knowledge, unless they have been given supervision or instruction.
- x **WARNING:** Due to the nature of the appliance, the floors around it may be slippery.

Reducing Fire Risk

- ✓ If materials inside the oven ignite, keep the oven door closed, turn the oven off, and disconnect the power cord or shut off power at the fuse or circuit breaker panel.
- ✓ If smoke is observed, switch off or unplug the oven. Keep the door closed to stifle any flames.
- x DO NOT put plastic or paper bags in the oven.
- x DO NOT use the cook cavity for storage purposes.
- x DO NOT overcook food. Carefully attend the oven if paper, plastic, or other combustible materials are placed inside to facilitate cooking.
- x DO NOT leave paper products, cooking utensils, or food in the cavity when the oven is not in use.

Grounding Instructions

This appliance must be grounded. In the event of an electrical short circuit, grounding reduces the risk of electric shock by providing an escape wire for the electric current. This oven is equipped with a cord that has a grounding wire with a grounding plug, which must be plugged into an outlet that is properly installed and grounded. Consult a qualified electrician or serviceman if uncertain about the ability to follow grounding instructions or if doubt exists as to whether the appliance is properly grounded.

- x DO NOT use an extension cord. If the power cord is too short, have a qualified electrician or serviceman install an outlet near the appliance.

 **WARNING:** Improper grounding can result in risk of electric shock.

Power Cord Replacement or Removal

If the power cord is damaged, it must be replaced by the manufacturer, its service agent, or a similarly qualified person.

 **WARNING:** If the oven is unplugged during service or maintenance, the user must be able to access and see the plug at all times to ensure that the oven remains unplugged. The plug must remain near the oven and cannot be placed behind another appliance or in another room.

Protective Earth (Ground) Symbol



This symbol identifies the terminal which is intended for connecting an external conductor for protection against electric shock in case of a fault, or the terminal of a protective earth (ground) electrode.

Equipotential Bonding Symbol



This symbol identifies the terminals which, when connected together, bring the various parts of an equipment or of a system to the same potential, not necessarily being the earth (ground) potential, e.g. for local bonding.

Specifications and Installation

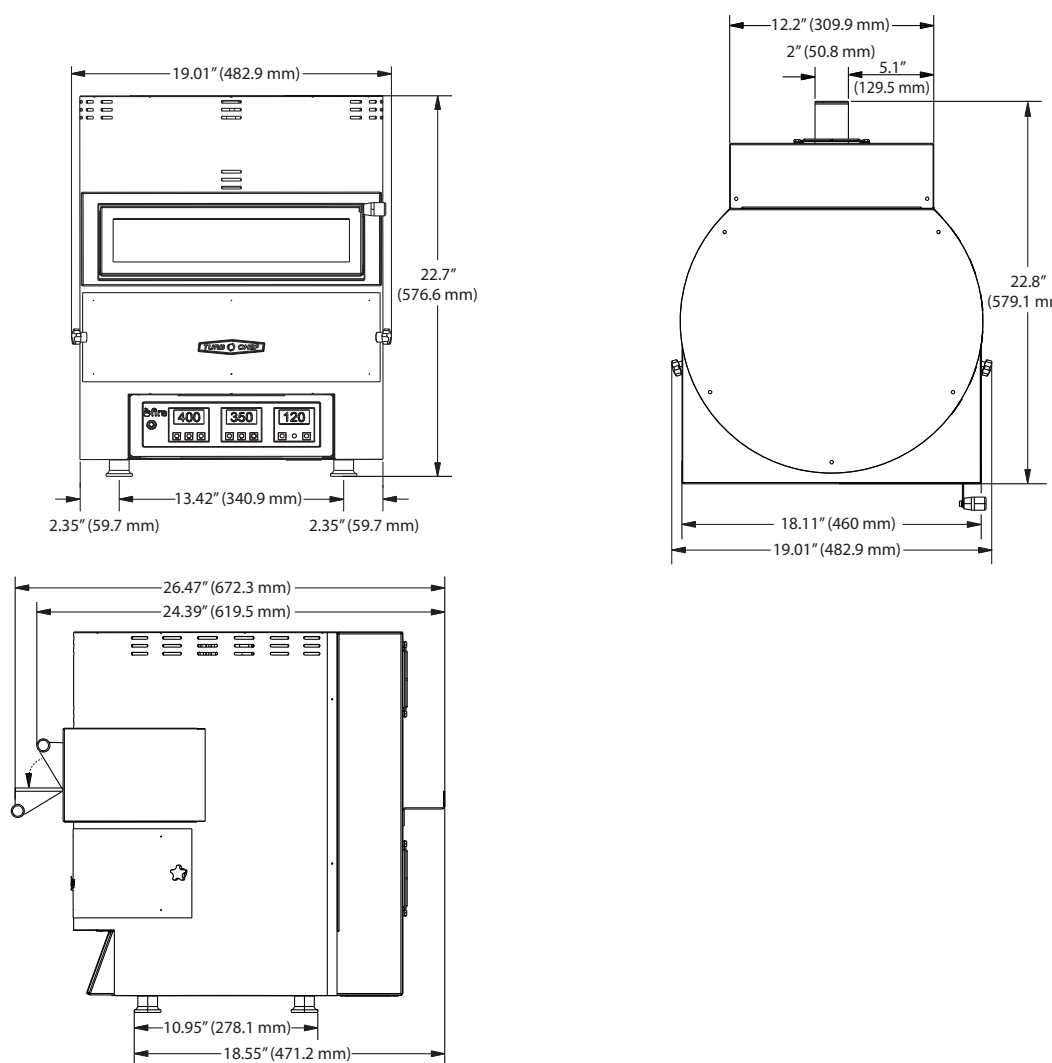

Figure 1: Fire Oven Dimensions

Performance

The TurboChef Fire provides the artisan hearth-style pizza experience anywhere. Cooking at 842°F/450°C, the Fire can cook 14-inch fresh dough pizzas in as little as 90 seconds. The oven is small and ventless, so it can be placed virtually anywhere without type I or type II ventilation.

This manual includes instructions for installing, cleaning, and operating the Fire oven. If you have questions that are not addressed in this manual, contact Customer Support at 800.90TURBO (+1 214.379.6000) or your Authorized Distributor.

Dimensions

Oven Dimensions

Height: 22.7" (576.6 mm)
 Width: 19.01" (482.9 mm)
 Depth (footprint): 18.55" (471.2 mm)
 Depth (door closed): 24.39" (619.5 mm)
 Depth (door open): 26.47" (672.3 mm)
 Weight: 75 lb. (34 kg)

Cook Cavity Dimensions

Width: 14.75" (374.7 mm)
 Depth: 14.75" (374.7 mm)

Clearances

Top: 2" (51 mm)
 Sides: 2" (51 mm)

Certifications

cULus, UL EPH



Oven Construction

Exterior

- Powder coated, corrosion-resistant steel outer wrap and door
- 430 stainless steel construction

Interior

- 430 stainless steel interior
- Double wall insulated cooling keeps external temperatures cool

Electrical Specifications

TurboChef recommends a Type D circuit breaker for all installations outside the United States.

Single Phase

North America: 208/240 VAC, 50/60 Hz, 3700/4800 W, 18/20 A, 30 A Plug

Europe/Asia/South America: 230 VAC, 50/60 Hz, 4500 W, 19.6 A, 32 A Plug

Australia: 230 VAC, 50/60 Hz, 4500 W, 19.6 A, 32 A Plug

Installation

Install or locate this appliance only in accordance with the instructions below.

Unpacking Instructions

1. Remove the oven from its packaging.
2. Before discarding, check the packaging thoroughly for accessories and literature.

NOTE: Packaging may also be retained in case the oven may at some point be shipped somewhere else or returned to the manufacturer.

3. Check the cook cavity thoroughly for accessories and literature.
4. Discard any packaging in the cook cavity.

Installation Warnings - Read Before Lifting Oven

 **WARNING:** The Fire oven weighs approximately 75 lb. (34 kg). Never lift with fewer than two people.

 **WARNING:** The oven must be properly placed on a food station at all times. TurboChef will not recognize a fallen oven as a warrantable claim and is not liable for any injuries that may result.

 **WARNING:** This oven is not intended for built-in installation (i.e., installing the oven in any structure that surrounds the oven by five or more sides). Be sure to provide a minimum of 2" (51 mm) clearance for all sides and 2" (51 mm) clearance for the top.

 **WARNING:** This oven is not intended to be stacked.

Lifting and Placing the Oven

1. Prepare a surface at least 18.55" (471.2 mm) deep and capable of supporting 80 lb (36.3 kg).

NOTE: Do not remove the oven legs.

2. Position one or more persons at the left and right sides of the oven.
3. Place hands under the oven and lift.
4. Place the oven on the prepared surface, ensuring no edges are hanging off the sides.
5. Ensure the lower access panel is properly installed (thumbscrews are tight), refer to Figure 6, Page 5 for illustration.
6. Plug in the oven.

Installation Near Open Heat Source

When placing a TurboChef oven near an open heat source (Figure 2), strictly adhere to the following:

- If the oven is being placed near a grill or stove, a divider must exist between the oven and the open heat source, with a minimum of 6" (152 mm) between the oven and the divider.
- If the oven is being placed near a fryer, a divider must exist between the oven and fryer, with a minimum of 12" (305 mm) between the oven and the divider.
- The height of the divider must be greater than or equal to the height of the oven (22.7" or 576.6 mm).
- Verify the oven location has a minimum 2" (51 mm) clearance on top and a minimum 2" (51 mm) clearance on each side.

Voltage Selection

For North America oven models, the oven will detect 208 or 240 incoming voltage.

Ventilation

The TurboChef Fire oven has been approved by Underwriter's Laboratory LLC for ventless operation (UL® KNLZ listing) for all food items except for foods classified as "fatty raw proteins." Such foods include bone-in, skin-on chicken, raw hamburger meat, raw bacon, raw sausage, steaks, etc. If cooking these types of foods, consult local HVAC codes and authorities to ensure compliance with ventilation requirements.

To ensure continued compliance with all health, building, and fire codes, you are required to maintain clean and sanitary conditions around your oven at all times.

NOTE: In no event shall the manufacturer assume any liability for damages or injuries resulting from installations which are not in compliance with the instructions and codes previously listed. Failure to comply with these instructions could result in the issuance of a temporary cease and desist order from the local health department until the environment concerns are addressed.

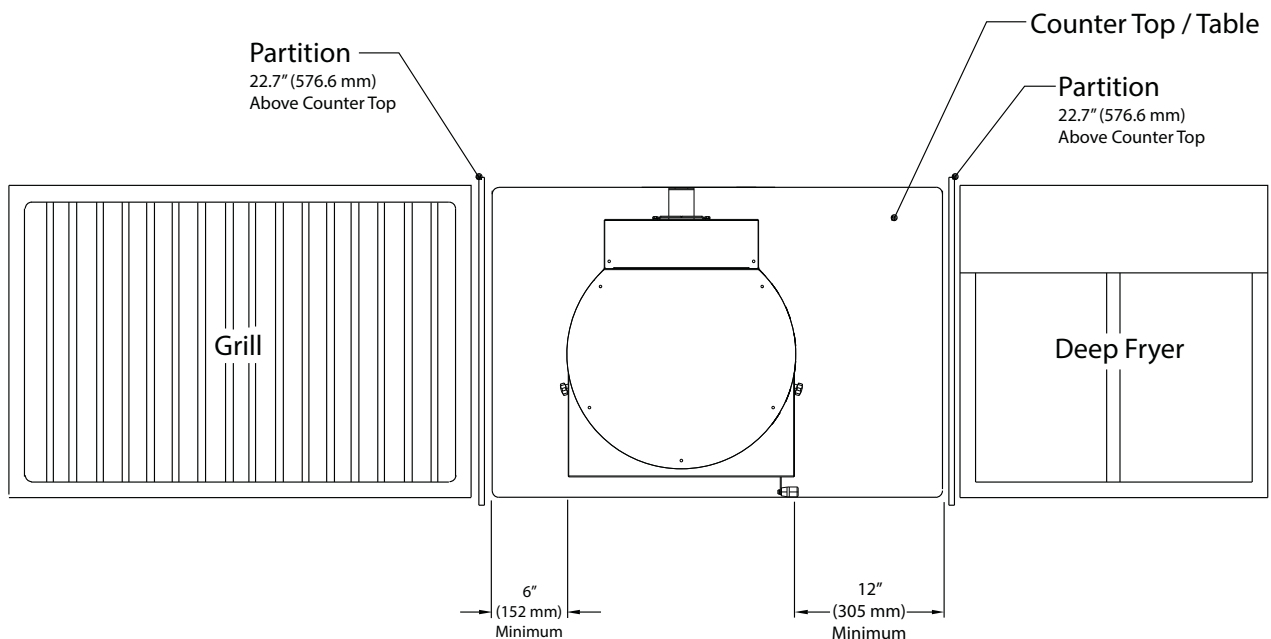



Figure 2: Installation Near Open Heat Source

Installing the Oven Handle

1. While the oven is off and cool, open the oven door (Figure 3).
2. Using a flat-head screwdriver, remove the two screws on the outside of the oven door (Figure 3).
3. Install the handle bracket as shown in Figure 4, using the screws removed in step 2.
4. Close the oven door.
5. Attach the handle to the bracket using the provided screw and washer (Figure 5).

 **CAUTION: DO NOT** over-tighten the handle. The handle may break if over-tightened.

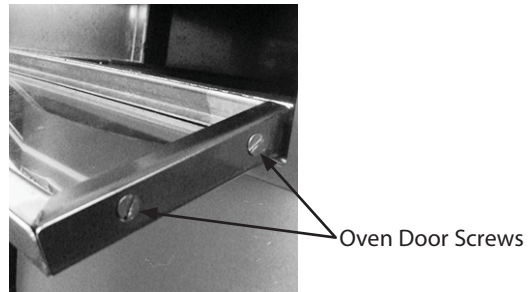

Figure 3: Oven Door Screw Location

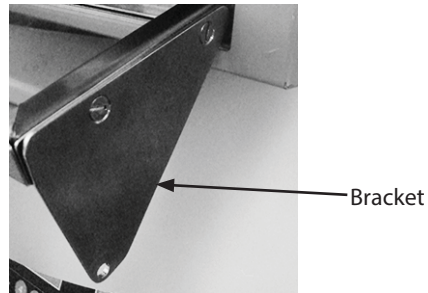

Figure 4: Bracket Installed to Oven Door

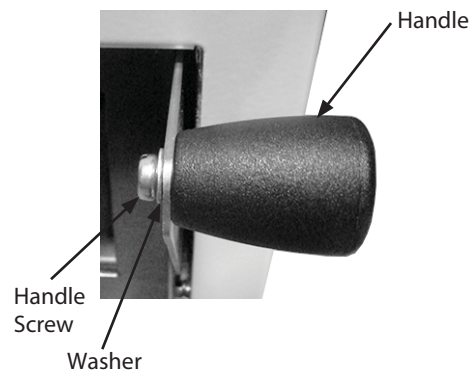

Figure 5: Handle Installed

Daily Maintenance

Daily Maintenance

Follow the steps below when cleaning your Fire oven. Use only TurboChef®-approved cleaning chemicals. The use of any other cleaning products may damage critical oven components, resulting in a non-warranty service call.

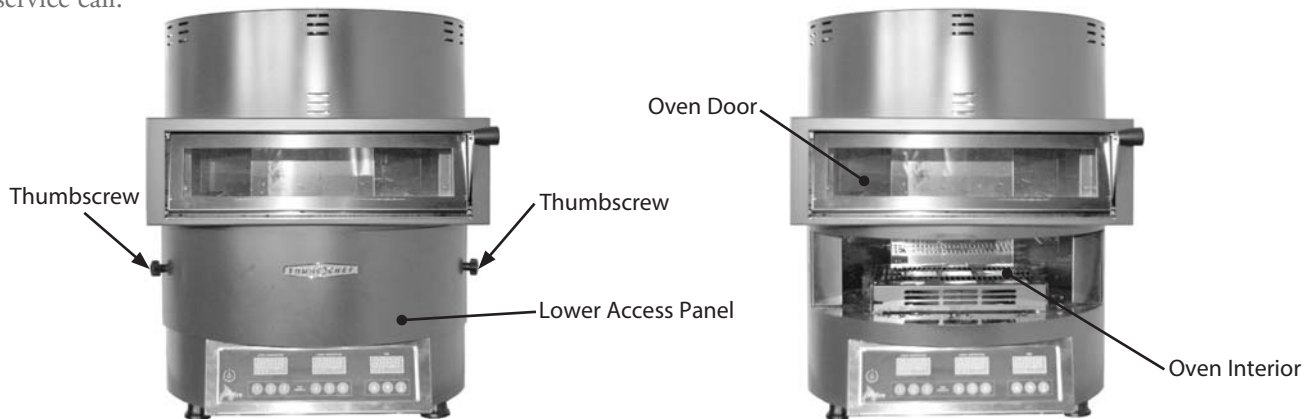

Figure 6: Maintenance

Step 1: Prepare the Oven

⚠ CAUTION: The oven operates at 842°F (450°C) and may cause injury if not allowed to cool properly.

- Turn off the oven by pressing the On/Off key.
- Cooling takes approximately two hours (or longer). DO NOT clean the oven until the oven is cool.

Step 2: Wipe the Oven Interior

- Remove the lower access panel by removing the two thumbscrews (see Figure 6, above).
- Use a food vacuum or damp towel to remove large particles from the oven interior.

Step 3: Clean the Oven Interior

- Spray TurboChef® Oven Cleaner onto a clean towel or nylon scrub pad and scrub the interior of the oven and the inside portion of the lower access panel.

⚠ CAUTION: DO NOT spray Oven Cleaner into any holes or openings in the oven interior. Doing so can damage critical oven components, resulting in a non-warranty service call.

- Open the oven door and gently wipe down the inside of the Door.
- If necessary, spray a small amount of Oven Cleaner on stains and allow to penetrate for five minutes, then clean with a nylon scrub pad.

Step 4: Rinse or Wipe the Oven Interior

⚠ CAUTION: DO NOT use a hose or water jet for cleaning. Doing so can damage critical oven components, resulting in a non-warranty service call.

- Wipe down the oven interior with a clean damp towel.
- Dry the oven interior with a clean towel.

Step 5: Clean the Oven Exterior

- Reinstall the lower access panel and secure it with the two thumbscrews.
- Wipe the oven exterior with a clean, damp towel.

⚠ CAUTION: DO NOT spray chemicals into any openings, such as the vents on the side and front or the perforation on the back. Doing so can damage critical oven components, resulting in a non-warranty service call.

- The oven is ready to turn on.

Supplies and Equipment

TurboChef® Oven Cleaner (Product Number: 103180), nylon scrub pad, cleaning towel, disposable gloves, protective eyewear, dust mask (optional)

*This page intentionally
left blank.*

Oven Operation

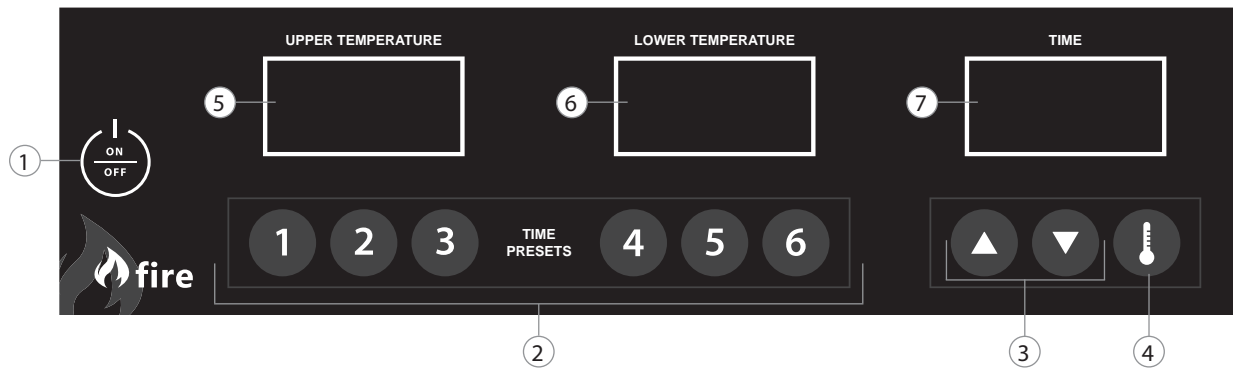

Figure 7: Oven Controls

Oven Controls

1. On/Off Key

Press to turn the oven on or off.

2. Time Preset Keys

Press presets 1 through 6 to activate a timer.

3. Up and Down Keys

Press the Up and Down keys to change the oven temperature (page 8), the time presets (page 8), or the parameters (pages 8-9).

4. Temperature Key

Press the Temperature Key to toggle between setting the upper and lower temperatures (page 8).

5. Upper Temperature Display

Displays the current Upper Temperature. A green light in the lower-left corner of this display will blink during warmup and turn solid once it has reached the set temperature.

6. Lower Temperature Display

Displays the current Lower Temperature. A green light in the lower-left corner of this display will blink during warmup and turn solid once it has reached the set temperature.

7. Time Display

Shows the amount of time left for the selected preset. The time is displayed in seconds, up to 1,999 (33 minutes and 19 seconds).

Cooking

1. Press the On/Off key to turn the oven on.
2. Allow the oven to warm up. The green light in the bottom-left corner of the Upper Temperature Display and the Lower Temperature Display will blink during warmup. Once the oven has finished warming up, the lights will stop blinking and stay solid.
3. Open the oven door and using the provided paddle and cooking screen, slide the product into the oven and close the oven door.
4. Press the desired timer (1 through 6).

NOTE: Once the timer reaches 0, the oven will begin beeping. To stop the beeping, press any of the Time Preset keys.

5. Open the oven door and remove the product from the oven and close the oven door.

! CAUTION: Dish and inside of oven/oven door are hot!

6. When finished cooking for the day, press the On/Off key to turn the oven off and begin cooling down.

Setting the Temperatures

Two different temperatures can be set: one for the upper heating zone and one for the lower heating zone. These temperatures range from off to 842°F (450°C).

NOTE: When a temperature is set to off, the display will read 32°F (0°C).

To set the temperature:

1. While the oven is on, press the Temperature key to access the upper temperature (the upper temperature will begin flashing).
2. Use the Up and Down keys to set the upper temperature.
3. Press the Temperature key again to save the upper temperature and to access the lower temperature.
4. Use the Up and Down keys to set the lower temperature.
5. Press the Temperature key again to save the lower temperature.

NOTE: If changing only one temperature, simply press the Temperature key to bypass the upper or lower temperature without changing it.

Setting the Timers

Six different timers can be set to accommodate different items.

To set a timer:

1. Make sure no timers are running.
2. While the oven is on, press and hold the desired timer button (1 through 6) for two seconds. The value indicated on the Time display will begin flashing.
3. Use the Up and Down keys to set the time.
4. Press and hold the same timer button for two seconds to save the time.

NOTE: If you wait five seconds without pressing any buttons, the timer will save automatically.

To pause a timer:

- Press any of the Time Preset keys. The time on the Time Display will flash to indicate the timer is paused.
- To resume the timer, press any of the Time Preset keys again.
- To reset the timer to 0, press and hold any of the Time Preset keys for two seconds. The oven will begin beeping to indicate the timer has reached zero. To stop the beeping, press any of the Time Preset keys.

Setting the Parameters

Access the parameter settings to change oven options. For a full list of parameters, descriptions, and values, see page 9.

To set the parameters:

1. While the oven is off, simultaneously press and hold the Time Preset 2 and 3 keys for two seconds. The Upper Temperature display will read "PA".
2. Press the Down key until the Time display reads "-19" (negative nineteen).
3. Simultaneously press and hold the Time Preset 2 and 3 keys for two seconds. The Upper Temperature display will now read "P0".
4. Refer to the table on page 9 and use the Time Preset 2 and 3 keys (increase and decrease parameter numbers) to navigate through the parameters.
5. Use the Up and Down keys to change the values.
6. When finished, press the On/Off key.

Parameter	Description	Unit of Measure	Minimum Value	Maximum Value	Default Value
P0	Temperatures shown in °C or °F (0 = °C, 1 = °F)	n/a	0	1	1
P1	Temperatre Displays (0 = Actual, 1 = Setpoint)	n/a	0	1	0
P2	Hysteresis Setting for Thermostat	°F/°C	36°F/2°C	48°F/9°C	4°F/2°C
P3	Offset of Top RTD	°F/°C	-22°F/-30°C	86°F/30°C	0°F/0°C
P4	Set Point Regulator (Top)	°F/°C	P5	P6	212°F/100°C
P5	Minimum Setting of Heater 1	°F/°C	32°F/0°C	P6	122°F/50°C
P6	Maximum Setting of Heater 1	°F/°C	P5	842°F/450°C	842°F/450°C
P7	Offset of Bottom RTD	°F/°C	-22°F/-30°C	86°F/30°C	0°F/0°C
P8	Set Point Regulator (Bottom)	°F/°C	P9	P10	212°F/100°C
P9	Minimum Setting of Heater 2	°F/°C	32°F/0°C	P10	122°F/50°C
P10	Maximum Setting of Heater 2	°F/°C	P9	842°F/450°C	842°F/450°C
P11	Cooling Fans Off Delay (K5 Relay)	Minutes	0	60	30
P12	Fan 1 and 2 Off Delay (K6 Relay)	Minutes	0	60	30
P13	Keyboard Cooling Fan Off Delay (K7 Relay)	Minutes	0	60	30
P14	Preset Timer 1	Seconds	P20	P21	80
P15	Preset Timer 2	Seconds	P20	P21	90
P16	Preset Timer 3	Seconds	P20	P21	100
P17	Preset Timer 4	Seconds	P20	P21	110
P18	Preset Timer 5	Seconds	P20	P21	120
P19	Preset Timer 6	Seconds	P20	P21	130
P20	Minimum Settable Time	Seconds	0	P21	0
P21	Maximum Settable Time	Seconds	P20	1,999	240
P22	Duration of Buzzer Sound	Seconds	0	60	15
P23	Enable Over Temperature Alarm (0 = Disable, 1 = Enable)	n/a	0	1	0
P24	Over Temperature Alarm Threshold	°F/°C	131°F/55°C	158°F/70°C	140°F/60°C
P25	Heater Modulation (0 = None, 1 = Voltage Module determines)	n/a	0	1	1
P26	Heat Cycle Time	Seconds	1	999	20
P27	Top Heater On Percentage	%	0	100	67
P28	Bottom Heater On Percentage	%	0	100	67
P29	Time between selection and timer start	Seconds	2	20	2

Front Panel Light Indicators

Each display (Upper Temperature, Lower Temperature, and Time) has three lights in the lower-left corner. From left to right, the lights are green - yellow - green.

Upper Temperature Lights:

- Left (Green) - Flashes during preheat. Turns solid when the oven reaches the set temperature.
- Middle (Yellow) - Not used.
- Right (Green) - Not used.

Lower Temperature Lights:

- Left (Green) - Flashes during preheat. Turns solid when the oven reaches the set temperature.
- Middle (Yellow) - Not used.
- Right (Green) - Turns on when the interior light is on. The interior light turns on when the On/Off Key is pressed and is controlled by the K4 relay.

Time:

- Left (Green) - Turns on when the cooling fans on the back panel are running (the K5 relay controls the cooling fans and the turn-off delay is set by the P11 parameter).
- Middle (Yellow) - Turns on when the interior cavity fans are running (the K6 relay controls the interior fans and the turn-off delay is set by the P12 parameter).
- Right (Green) - Turns on when the controls cooling fan is running (the K7 relay controls the interior fans and the turn-off delay is set by the P13 parameter).

Troubleshooting

Troubleshooting: Fault Code Er1

Er1 is displayed on the upper temperature display and indicates a damaged upper RTD. The oven will beep when this error occurs.

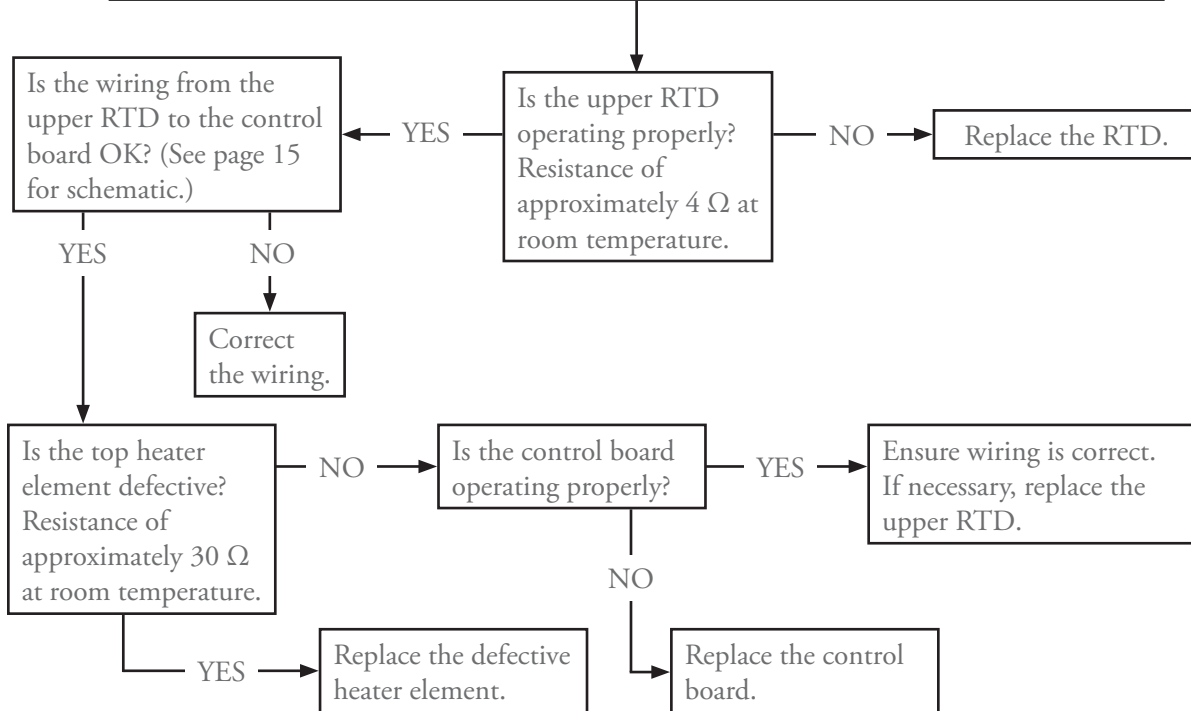

Troubleshooting: Fault Code Er2

Er2 is displayed on the lower temperature display and indicates a damaged lower RTD. The oven will beep when this error occurs.

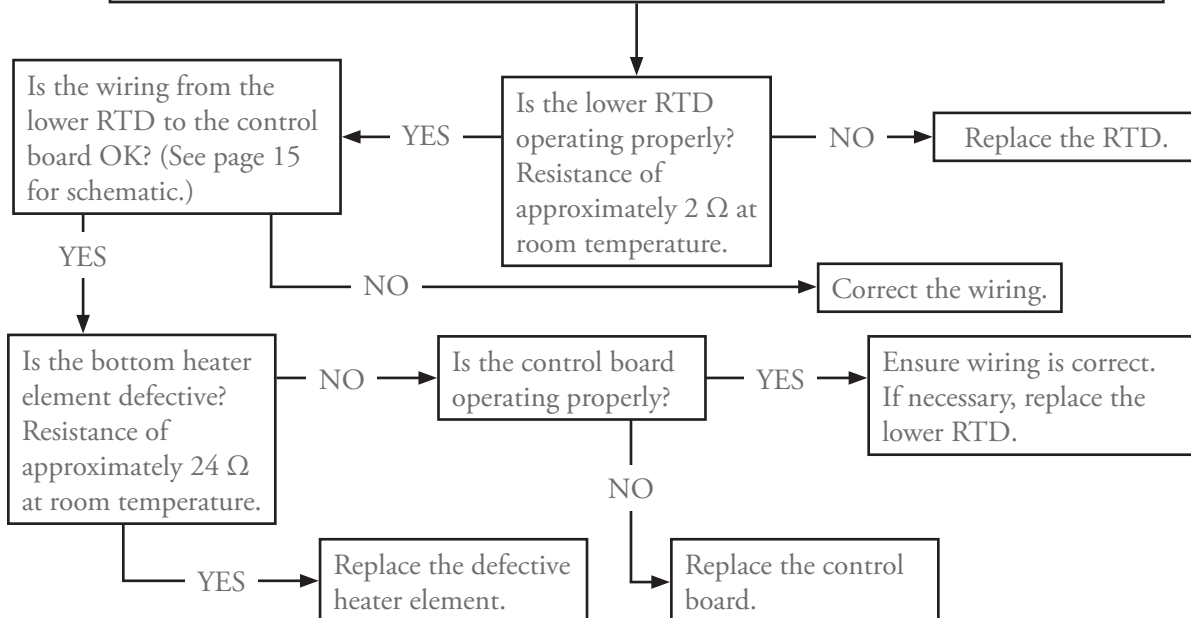

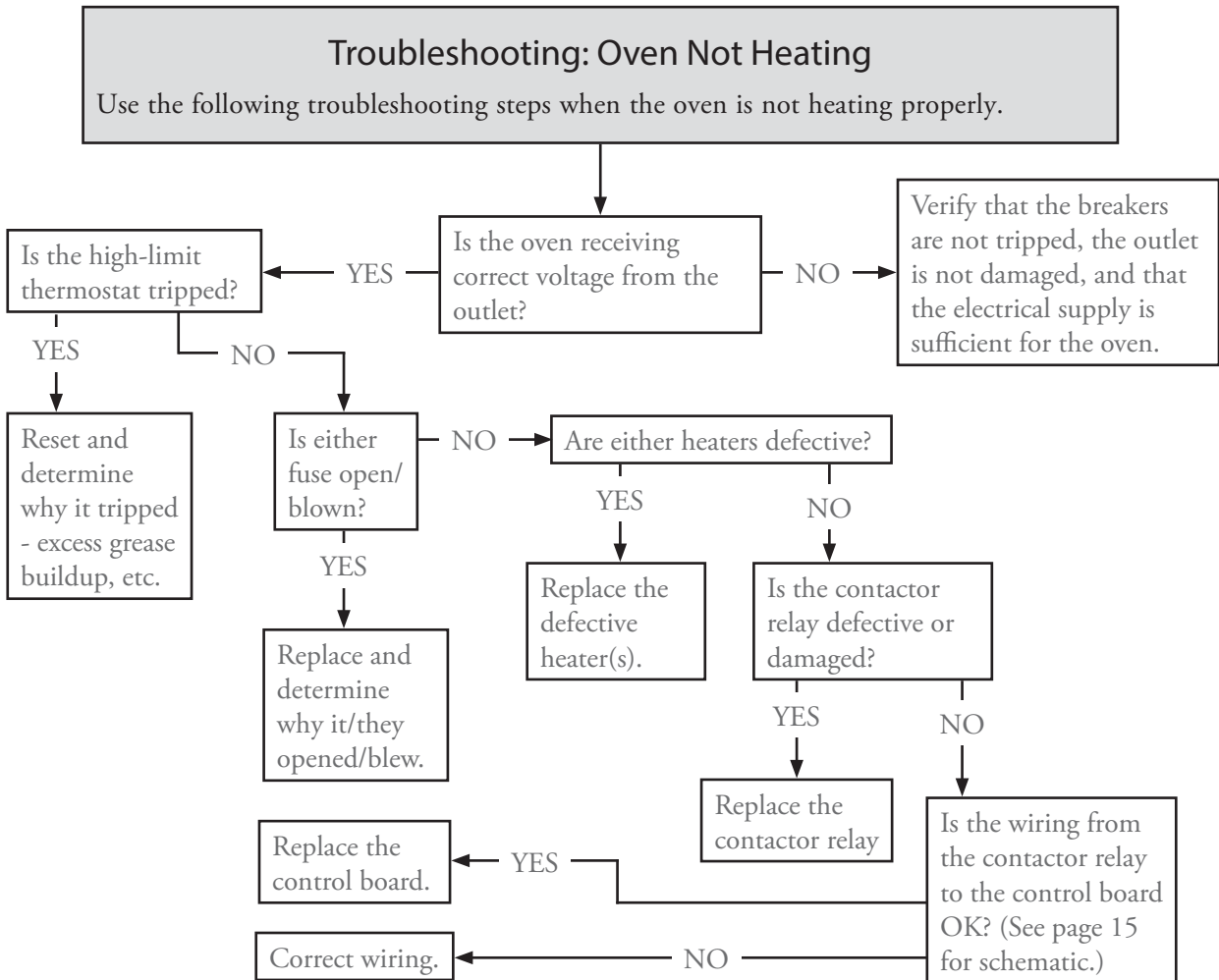
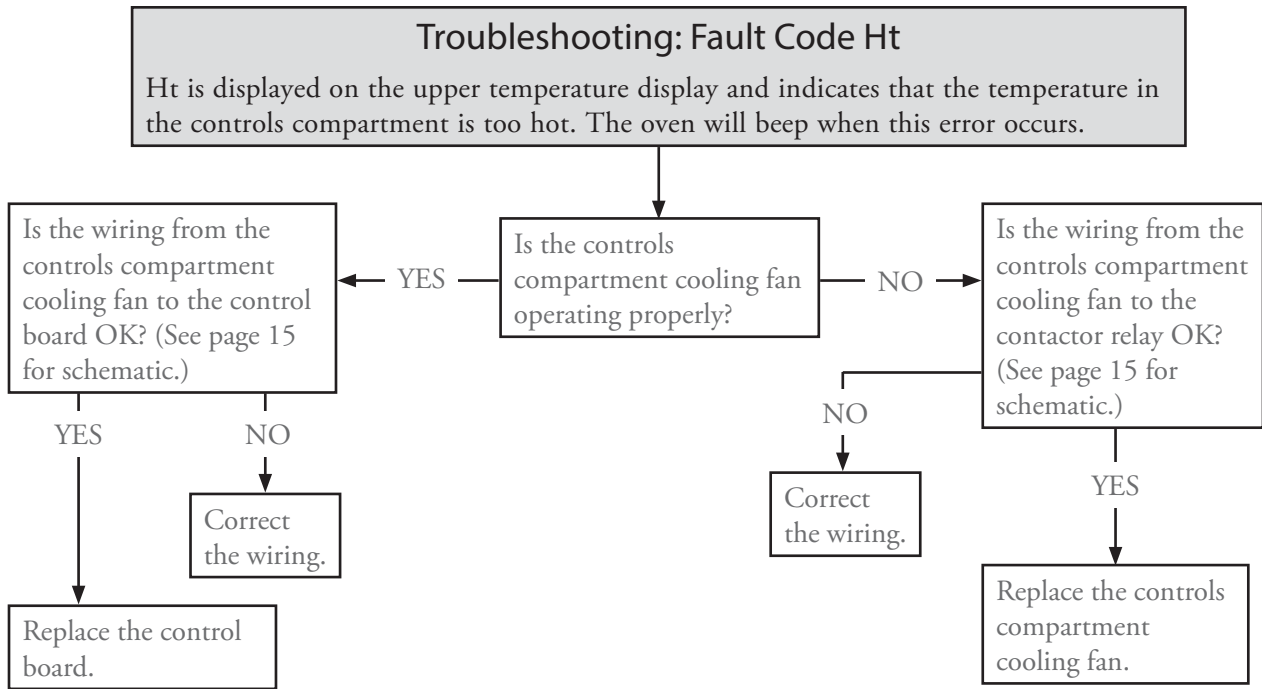

*This page intentionally
left blank.*

Oven Schematic

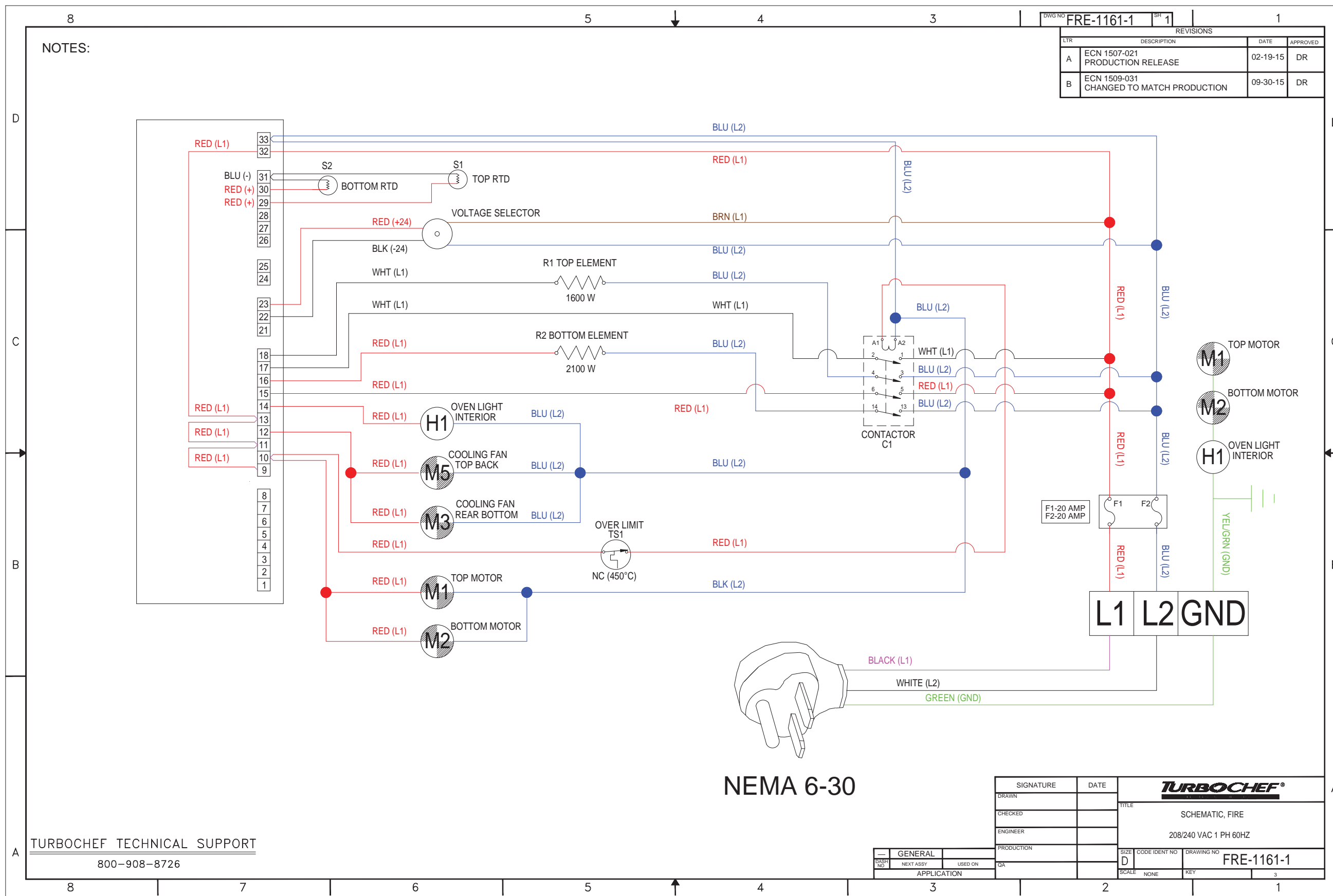
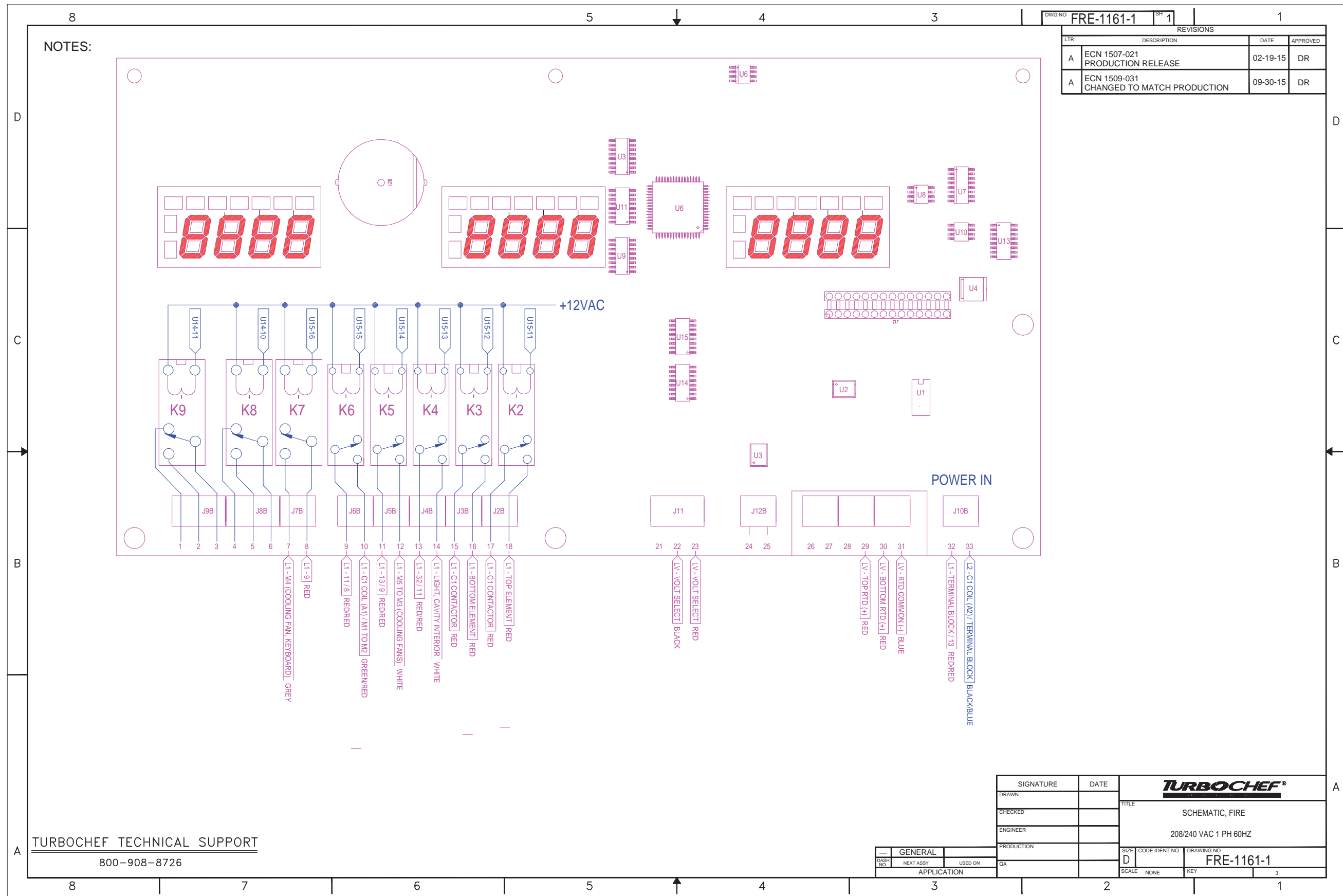

Figure 8: Oven Schematic - Single Phase



NOTES:

REVISIONS			
LTR	DESCRIPTION	DATE	APPROVED
A	ECN 1507-021 PRODUCTION RELEASE	02-19-15	DR
A	ECN 1509-031 CHANGED TO MATCH PRODUCTION	09-30-15	DR

TURBOCHEF TECHNICAL SUPPORT
800-908-8726

SIGNATURE	DATE	TURBOCHEF®		
DRAWN				
CHECKED		TITLE		
ENGINEER		SCHEMATIC, FIRE		
PRODUCTION		208/240 VAC 1 PH 60HZ		
DASH NO	NEXT ASSY	SIZE	CODE IDENT NO	DRAWING NO
	USED ON	D		FRE-1161-1
APPLICATION		SCALE	NONE	KEY
				3

Figure 9: Control Board Schematic

Appendix

Replacing Oven Components

Replacing Oven Components

This appendix provides illustrations for removing serviceable items, as well as the item numbers and descriptions for those items. It also includes the item numbers and descriptions for the fasteners used to secure each component to the oven chassis.

If you have any questions that are not addressed in this manual or appendix, please contact TurboChef Customer Service at 800.90TURBO or +1 214.379.6000.

Replacing Items

⚠ DANGER: Before replacing any oven component, ensure the oven is removed from any power source. Replacing a component while the oven is plugged in can result in serious injury or death

⚠ CAUTION: Be careful to not tear the insulation when servicing components. Always reinstall the insulation properly before reinstalling the outer shell.

NOTE: Fasteners listed are required for installing component to oven.

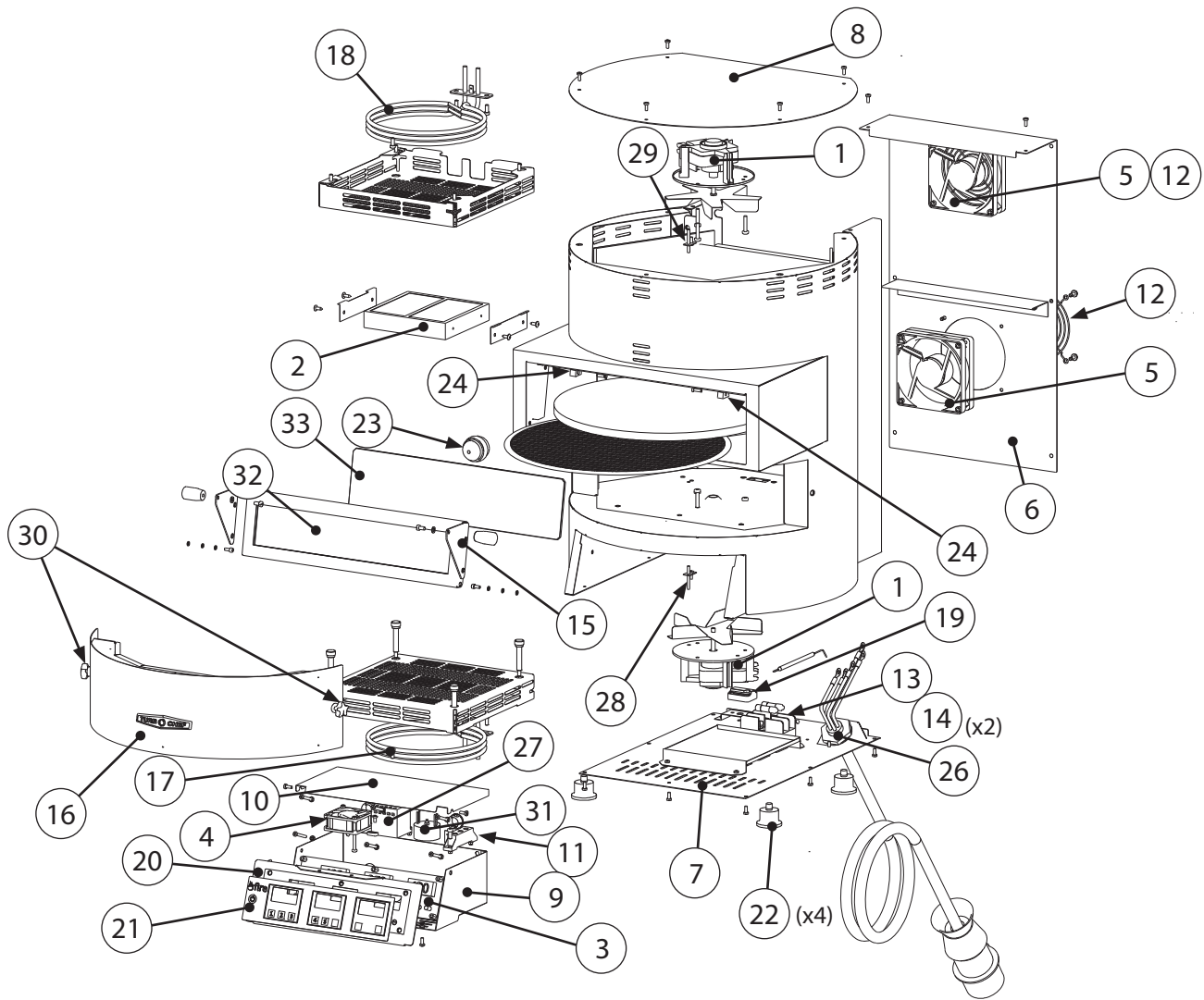

Figure Reference #	Item Description	Item Part Number	Fastener Description	Fastener Part Number(s)
1	Blower Motor*	FRE-3001 (x2)	Screw, PPH, SS, M5x25mm LGx .8mm	101344 (qty 2)
2	Catalytic Converter	FRE-1019	Screw, SH MTL, #8 x 1/2 Serrated PHTRH Bracket, Catalyst Holder	101688 (qty 4) FRE-1013 (qty 2)
3	Control Board	FRE-3006	Screw, PFH, SS, M4x35mm LGx .8mm	101439 (qty 6)
4	Cooling Fan, Controls	FRE-1046	Screw, PPH, SS, M4x30mm LGx .8mm Nut, Hex, SS, M4	101699 (qty 2) 101004 (qty 2)
5	Cooling Fan, Rear	100516 (x2)	Screw, #10-32x1/2, Hex WSHR HD, Type 23 (Shared with Finger Guard)	101408 (qty 4)

*Ensure that the blower motor is properly aligned.

Figure Reference #	Item Description	Item Part Number	Fastener Description	Fastener Part Number(s)
6	Cover, Back	FRE-1016	Screw, M4x10mm LG, PPHD, S.S.	101671 (qty 8)
7	Cover, Bottom	FRE-1133	Screw, M4x10mm LG, PPHD, S.S.	101671 (qty 7)
8	Cover, Top	FRE-1059-1 (Red) FRE-1059-2 (Green) FRE-1059-3 (Yellow) FRE-1059-4 (White) FRE-1059-5 (Black) FRE-1059-6 (Blue)	Screw, M4x10mm LG, PPHD, S.S.	101671 (qty 5)
9	Display Housing	FRE-1112	Screw, M4x10mm LG, PPHD, S.S.	101671 (qty 2)
10	Display Housing, Cover	FRE-1087	Screw, M4x10mm LG, PPHD, S.S.	101671 (qty 4)
11	Distribution Block	FRE-1048	Screw, M5x12, Hex PPHD, CRES	101676 (qty 2)
12	Finger Guard	100087 (x2)	Screw, #10-32x1/2, Hex WSHR HD, Type 23 (Shared with Cooling Fan, Rear)	101408 (qty 4)
13	Fuse Holder	103548	Screw, M4x10mm LG, PPHD, S.S.	101671 (qty 2)
14	Fuse, F1 and F2, 20-amp	100599	None	None
15	Handle, Kit (kit includes bracket and hardware)	FRE-3007	Included	Included
16	Hatch, Front (kit includes thumb screws)	FRE-3008-1 (Red) FRE-3008-2 (Green) FRE-3008-3 (Yellow) FRE-3008-4 (White) FRE-3008-5 (Black) FRE-3008-6 (Blue)	Included	Included
17	Heater, Bottom (approximately 24 Ω at room temperature)	FRE-3003	Included	Included
18	Heater, Top (approximately 30 Ω at room temperature)	FRE-3002	Included	Included
19	High Limit Thermostat	FRE-1050	Screw, M4x10mm LG, PPHD, S.S.	101671 (qty 2)
20	Keypad Back Panel	FRE-1113	Screw, M4x10mm LG, PPHD, S.S.	101671 (qty 2)
21	Keypad Overlay	FRE-1150	None	None
22	Leg	FRE-1055	None	None
23	Light Bulb with Lens and Socket	FRE-3005	None	None
24	Magnet	FRE-1162 (x2)	Screw, FL HD Slot, SS, 90° M4x16mm LG, .7 Pitch	101428
25	Paint, Touch-Up Kit (not shown)	FRE-3009	None	None
26	Power Cord, Domestic Power Cord, International Power Cord, Australia	100187 100195 i1-9136	None	None
27	Relay, Contactor	FRE-1060	Screw, M4x8mm LG, PPHD, S.S.	101670
28	RTD, Lower (approximately 2 Ω at room temperature)	FRE-1053	Screw, M4x10mm LG, PPHD, S.S.	101671
29	RTD, Upper (approximately 4 Ω at room temperature)	FRE-1052	Screw, M4x10mm LG, PPHD, S.S.	101671
30	Screw, Thumb	FRE-1163	None	None
31	Voltage Module	100783	Screw, PPH, SS, M4x30mm LGx .8mm Nut, Hex, SS, M4	101699 101004
32	Window, Assembled	FRE-3010	Included	Included
33	Window, Glass	FRE-3004	Included	Included
34	Wire Harness (not shown)	FRE-1160	None	None

For service or information:

WITHIN NORTH AMERICA CALL

Customer Support *at* 800.90TURBO

OUTSIDE NORTH AMERICA CALL

+1 214.379.6000 or Your Authorized Distributor



Part Number: FRE-1002 / Revision D / September 2015
Country Code: NA/EU

Global Operations

2801 Trade Center Drive
Carrollton, Texas 75007 USA
+1 214.379.6000 PHONE
+1 214.379.6073 FAX

TurboChef International

Business & Technology
Centre
Bessemer Drive
Stevenage
Herts SG1 2DX
United Kingdom
+44 8456021544 PHONE
+44 8456021636 FAX

Customer Support

800.90TURBO
+1 214.379.6000
turbochef.com