

MAKING MODERN LIVING POSSIBLE

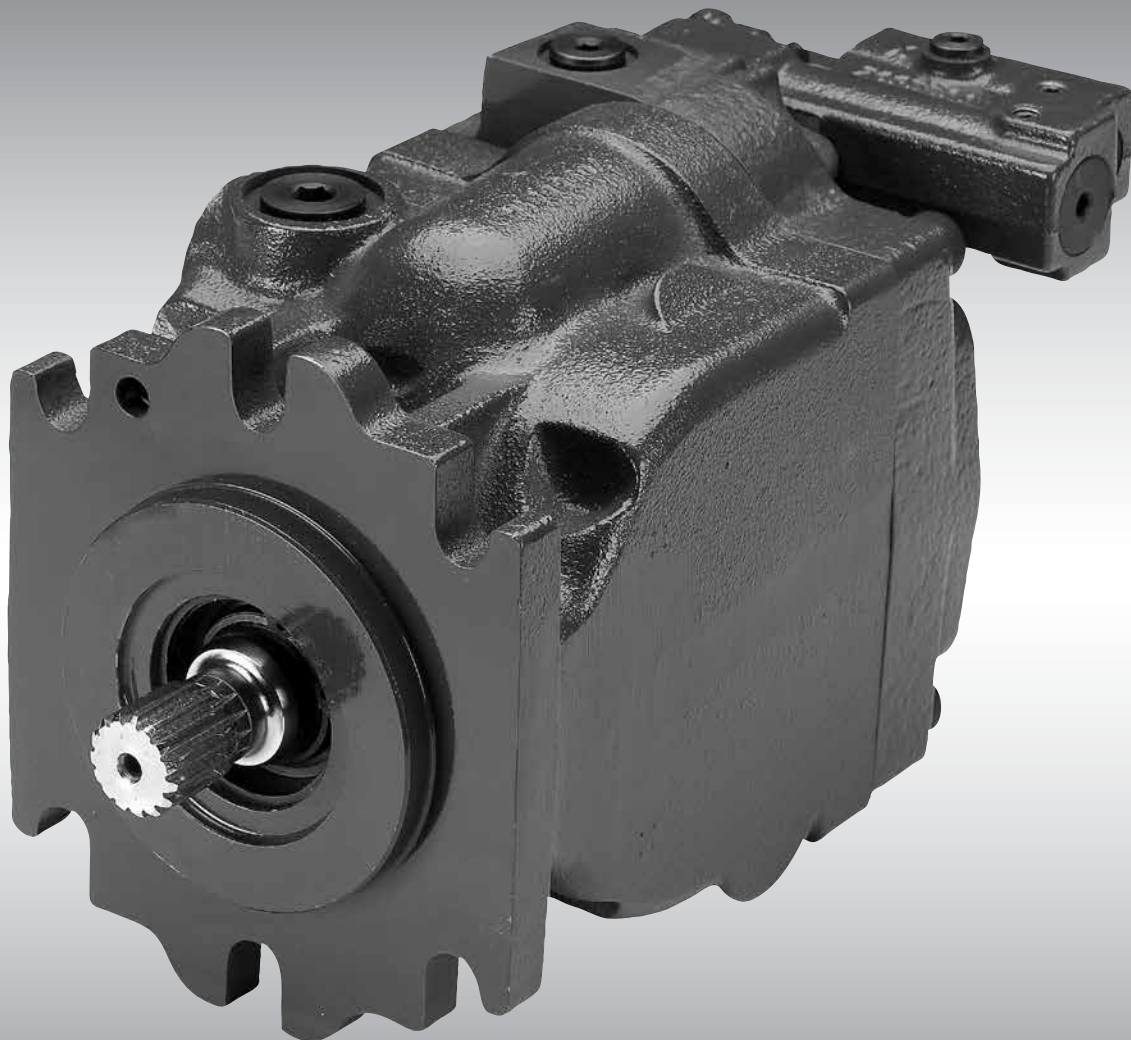

Service Manual

Series 45 J Frame Open Circuit Axial Piston Pumps



History of Revisions*Table of Revisions*

Date	Page	Changed	Rev.
September 2013	-	Danfoss conversion	AI
December 2012	9	Displacement limiter is available - change to max. pressure	AH
October 2012	various	add electric controls	AG
November 2010	last	new last page	AF
February 2010	last	Fix Osaka address	AE
July 2009	20	Pressure change - PC adjustment specs	AD
March 2007	21	typo in illustration - set screw torque is 7.5-10.8Nm [5.5 -8 lbf·ft]	AB
May 2005	-	First edition	A

Contents

Introduction	Overview	5
	Safety precautions.....	5
	Unintended machine movement	5
	Flammable cleaning solvents.....	5
	Fluid under pressure	5
	Personal safety.....	5
	Symbols used in Danfoss literature.....	6
	General description.....	7
	System circuit	8
Technical Specifications	General specifications.....	9
	Hydraulic parameters.....	10
	Inlet pressure	10
	Pressure compensator valve setting.....	10
	Case pressure.....	10
	Hydraulic fluid	10
	Fluid viscosity	10
	Filtration	10
Features	Auxiliary mounting pads.....	11
	Input shafts	11
	Control options.....	12
	PC control.....	12
	LS control	13
	Electric Proportional Controls.....	14
	Electric On/Off Controls.....	14
Pressure Measurement	Required tools	15
	Port locations and gauge installation	15
Initial Start-up Procedures	General.....	16
	Start-up procedure.....	16
Fluid and Filter Maintenance	Recommendations	17
Troubleshooting	Excessive noise and/or vibration.....	18
	Actuator response is sluggish	18
	System operating hot.....	19
	Low pump output flow	19
	Pressure or flow instability	19
	Pressure or flow instability (continued).....	20
	System pressure not reaching PC setting.....	20
	High inlet vacuum	20

Contents (continued)

Adjustments

PC control..... 21
LS control 22

Minor repair

Shaft seal replacement 23
Auxiliary pads 24
LS and PC Controls..... 25
LS and PC Controls (continued) 26
Electric Controls..... 27
Servo Control Orifice..... 29
Plug and fitting sizes and torques 30

Introduction

Overview

This manual includes information for the installation, maintenance, and minor repair of the Series 45 frame J open circuit axial piston pumps. The manual includes a description of the units and their individual components, troubleshooting information, and minor repair procedures. Performing installation, maintenance, and minor repair of Series 45 J frame axial piston pumps according to the procedures in this manual will not affect your warranty.

Performing minor repairs requires the unit to be removed from the vehicle/machine. Thoroughly clean the unit before beginning maintenance, or repair activities. Since dirt and contamination are the greatest enemies of any type of hydraulic equipment, follow cleanliness requirements strictly. This is especially important when changing the system filter and when removing hoses or plumbing.

A worldwide network of Danfoss **Authorized Service Centers (ASCs)** is available for major repairs. Major repairs require the removal of the unit's endcap, which voids the warranty unless done by an ASC. Danfoss ASCs are trained by the factory and certified on a regular basis. You can locate your nearest ASC using the distributor locator at www.Danfoss.com

Safety Precautions

Always consider safety precautions before beginning a service procedure. Protect yourself and others from injury. Take these general precautions whenever servicing a hydraulic system.

Unintended machine movement

▲ Warning

Unintended movement of the machine or mechanism may cause injury to the technician or bystanders. To protect against unintended movement, secure the machine or disable / disconnect the mechanism while servicing.

Flammable cleaning solvents

▲ Warning

Some cleaning solvents are flammable. To avoid possible fire, do not use cleaning solvents in an area where a source of ignition may be present.

Fluid under pressure

▲ Warning

Escaping hydraulic fluid under pressure can have sufficient force to penetrate your skin causing serious injury and/or infection. This fluid may also be hot enough to cause burns. Use caution when dealing with hydraulic fluid under pressure. Relieve pressure in the system before removing hoses, fittings, gauges, or components. Never use your hand or any other body part to check for leaks in a pressurized line. Seek medical attention immediately if you are cut by hydraulic fluid.

Personal safety

▲ Warning

Protect yourself from injury. Use proper safety equipment, including safety glasses, at all times.

Introduction (continued)

Symbols used in Danfoss Literature

These symbols are in the illustrations and text of this manual. They communicate helpful information at the point where it is most useful to the reader.

In most instances, the appearance of the symbol itself denotes its meaning. The legend below defines the symbol and explains its purpose.

- | | | | |
|--|---|--|--|
| | WARNING may result in injury | | Tip, helpful suggestion |
| | CAUTION may result in damage to product or property | | Lubricate with hydraulic fluid |
| | Reusable part | | Apply grease/petroleum jelly |
| | Non-reusable part, use a new part | | Apply locking compound |
| | Non-removable item | | Inspect for wear or damage |
| | Option – either part may exist | | Clean area or part |
| | Superseded – parts are not interchangeable | | Be careful not to scratch or damage |
| | Measurement required | | Note correct orientation |
| | Flatness specification | | Mark orientation for reinstallation |
| | Parallelism specification | | Torque specification |
| | External hex head | | Press in – press fit |
| | Internal hex head | | Pull out with tool – press fit |
| | Torx head | | Cover splines with installation sleeve |
| | O-ring boss port | | Pressure measurement/gauge location or specification |

Introduction (continued)

General Description

Danfoss Series 45 J frame open circuit piston pumps convert input torque into hydraulic power. Rotational force is transmitted through the input shaft to the cylinder block. The input shaft is supported by tapered roller bearings at the front and rear of the pump and is splined into the cylinder block. A lip-seal at the front end of the pump prevents leakage where the shaft exits the pump housing. The spinning cylinder block contains nine reciprocating pistons. Each piston has a brass slipper connected at one end by a ball joint. The slippers are held to the swashplate by the spring retainer and block spring. The block spring also holds the cylinder block to the valve plate. The reciprocating movement of the pistons occurs as the slippers slide against the inclined swashplate during rotation. Via the valve plate, one half of the cylinder block is connected to pump inlet and the other half to pump outlet. As each piston cycles in and out of its bore, fluid is drawn from the inlet and displaced to the outlet thereby imparting power into the system circuit. A small amount of fluid is allowed to "leak" from the cylinder block/valve plate and slipper/swashplate interfaces for lubrication and cooling. Case drain ports are provided to return this fluid to the reservoir.

The volume of fluid displaced into the system circuit is controlled by the angle of the swashplate. The swashplate is forced into an inclined position (into stroke) by the bias spring. The servo piston opposes the action of the bias spring forcing the swashplate out of stroke when hydraulic pressure in the control circuit rises above the spring force.

The pump control, by varying the pressure at the servo piston, controls the displacement of fluid in the system circuit. Controls designed for **Pressure Compensation (PC)** or **Load Sensing (LS)** are available. For a detailed description of control operation, refer to *Control options, operation*, page 12.

Pump and control sectional view

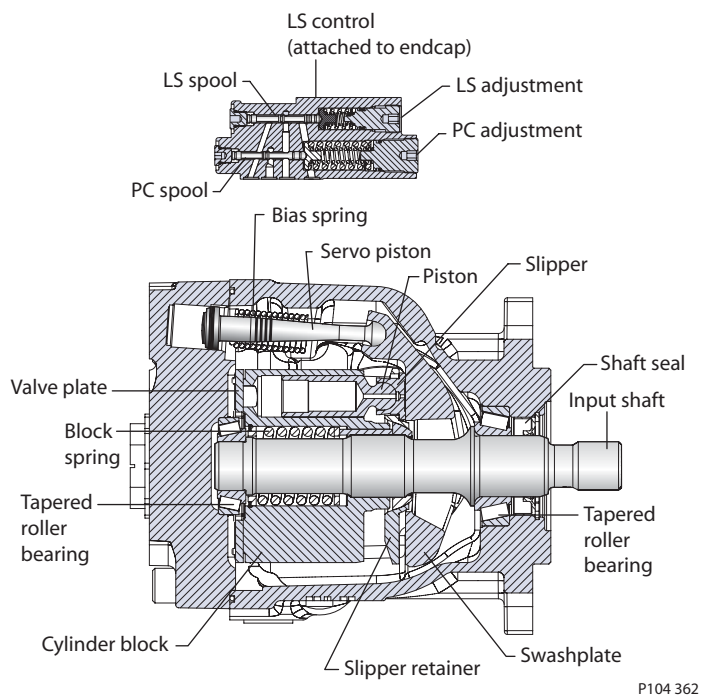

Introduction (continued)

System Circuit

The pump receives fluid directly from the reservoir through the inlet line. A screen placed in the inlet protects the pump from large contaminants. The output of the pump is directed to a PVG-32 multi-section load sensing directional control valve which directs fluid to the actuators in the system. Fluid returning from the system is cooled by a heat exchanger and cleaned by a filter before returning to the reservoir.

The speed of the actuators in the system depends on the volume of fluid being provided by the pump. The operating pressure varies depending on actuator load, but is limited to an adjustable maximum setting by the PC section of the pump control and by a system relief valve integrated into the side module of the PVG valve.

The position of the PVG valve sets the demand for flow in the system and communicates this to the pump control by means of a hydraulic signal (load sense signal). The pump will provide as much flow to the system as it demands¹ while limiting the maximum pressure. Therefore flow and pressure in the system are compensated to meet requirements.

Pictorial circuit diagram

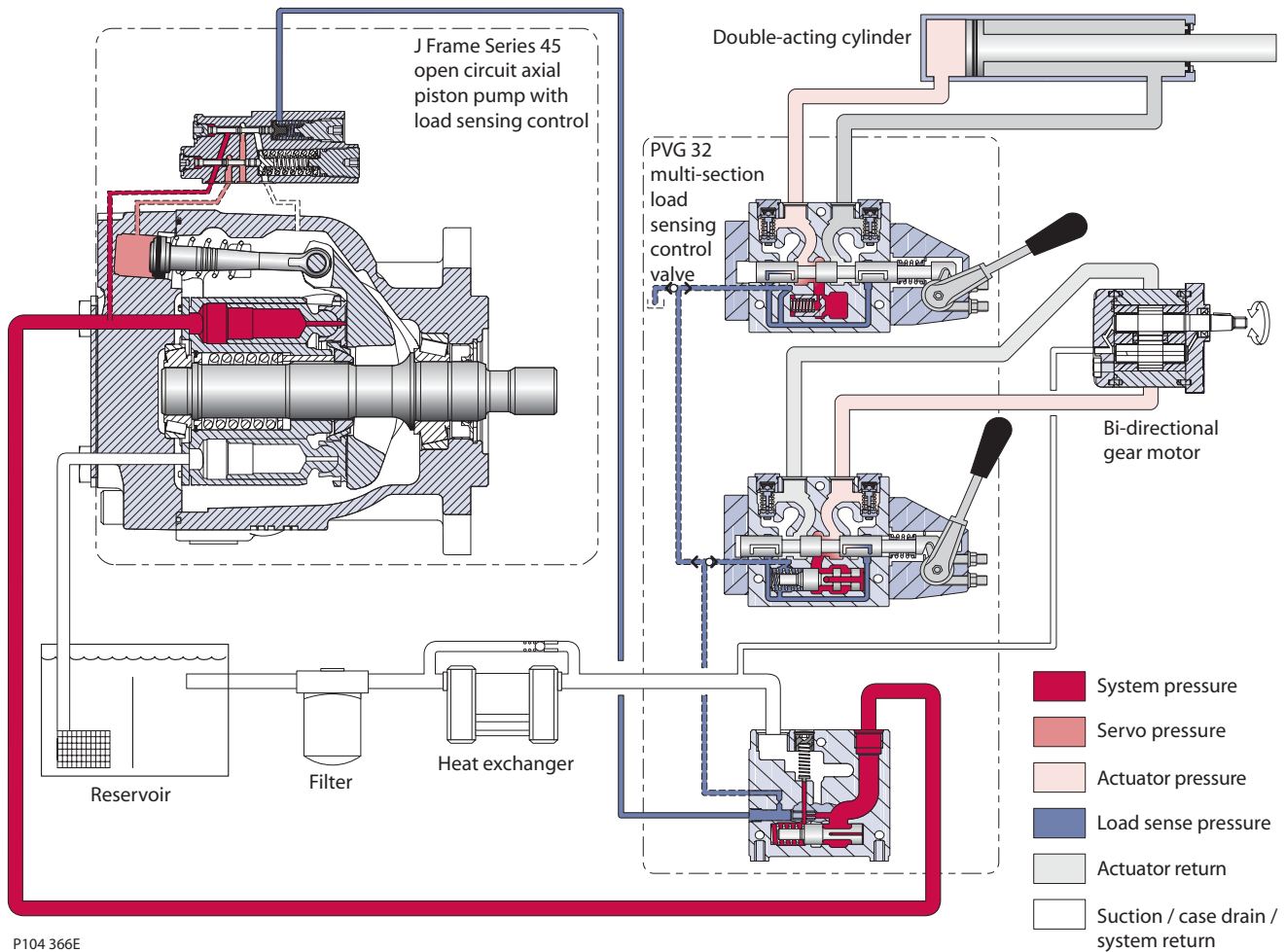

P104 366E

¹ Full available flow is a function of pump displacement, operating speed, and efficiency. Refer to *Series 45 Axial Piston Open Circuit Pumps Technical Information*, 520L0676 for details.

Technical Specifications
General Specifications

<i>Features and options</i>		Model				
		J45B	J51B	J60B	J65C	J75C
Feature	Unit					
Maximum Displacement	cm ³ [in ³]	45 [2.75]	51 [3.11]	60 [3.66]	65 [3.97]	75 [4.58]
Flow at rated speed (theoretical)	l/min [US gal/min]	126.0 [33.3]	137.7 [36.4]	156.0 [41.2]	162.6 [42.9]	180 [47.5]
Input torque at maximum displacement (theoretical)	N•m/bar [lbf•in/1000 psi]	0.716 [436.9]	0.811 [495.1]	0.956 [583.6]	1.035 [631.4]	1.193 [728.1]
Mass moment of inertia of internal rotating components	kg•m ² [slug•ft ²]	0.00455 [0.00336]	0.00455 [0.00336]	0.00455 [0.00336]	0.00433 [0.00319]	0.00433 [0.00319]
Weight	Axial ports	23.13 [51]				
	Radial ports	26.65 [58.8]				
Rotation		Clockwise, Counterclockwise				
Mounting		2 bolt SAE-B, 4 bolt SAE-C				
Auxiliary mounting		SAE-A, SAE-B, SAE-BB, SAE-C				
System ports (type)		SAE R-ring boss. 4-bolt split flange				
System ports (location)		Axial, Radial				
Control types		PC, Remote PC, LS, LS with internal bleed				
Shafts	Splined	13-tooth, 14-tooth, 15-tooth				
	Tapered	Ø 31.75 mm [1.25 in], 1:8 taper				
	Straight	Ø 31.75 mm [1.25 in]				
Displacement limiters		Available				

<i>Ratings</i>			Model				
Rating		Units	J45B	J51B	J60B	J65C	J75C
Input speed ¹	minimum	min ⁻¹ (rpm)	500	500	500	500	500
	continuous		2800	2700	2600	2500	2400
	maximum		3360	3240	3120	3000	2880
Working pressure	maximum	bar [psi]	310 [4495]	310 [4495]	310 [4495]	260 [3770]	260 [3770]
External shaft loads	External moment (M _e)	N•m [lbf•in]	226 [2000]	226 [2000]	226 [2000]	226 [2000]	226 [2000]
	Thrust in (T _{in}), out (T _{out})	N [lbf]	2200 [495]	2200 [495]	2200 [495]	2200 [495]	2200 [495]
Bearing life	at 140 bar [2030 psi]	B ₁₀ hours	29 712	29 712	29 712	10 755	10 755
	at 210 bar [3045 psi]		6834	6834	6834	2474	2474
	at 260 bar [3770 psi]		3151	3151	3151	—	—
	at 310 bar [4495 psi]		1666	1666	1666	—	—
Mounting flange load moments	Vibratory (continuous)	N•m [lbf•in]	SAE-C: 1500 [14 000], SAE-B: 735 [6500]				
	Shock (max)		SAE-C: 5600 [50 000], SAE-B: 2600 [23 000]				

1. Continuous input speeds are valid at 1 bar absolute [0 in HG vac] inlet pressure. Maximum input speeds require changing the inlet pressure or reducing pump displacement.

Technical specifications

Hydraulic Parameters

Inlet pressure

Minimum pressure, continuous = 0.8 bar absolute [6.7 inches Hg vac.]
(at reduced maximum pump speed)

Minimum pressure, cold start = 0.5 bar absolute [15.1 inches Hg vac.]

Pressure compensator valve setting

Minimum: 100 bar [1450 psi]
Maximum: 310 bar [3770 psi] (depending on displacement)

For more information, refer to *Series 45 J Frame Axial Piston Open Circuit Pumps Technical Information, 520L0676*.

Case pressure

Maximum continuous: 0.5 bar [7 psi] Above inlet
Intermittent: 2 bar [29 psi] Cold start

Hydraulic fluid

Refer to Danfoss publication *Fluids and Filtration* BLN-9887 or **520L0463**. For information on biodegradable fluids refer to *Biodegradable Hydraulic Fluids, 520L0465*. See *Fluid and filter maintenance*, page 17 for recommended fluid and filter change intervals.

Temperature range¹

Intermittent (cold start): - 40° C [- 40° F]
Continuous: 82° C [180° F]
Maximum²: 104° C [220° F]

Fluid viscosity

Viscosity limits

Rating		mm ² /s (cSt) [SUS]
v continuous	minimum	9 [58]
	maximum	110 [500]
v intermittent	minimum	6.4 [47]
	maximum (cold start)	1000 [4700]

Filtration

Required cleanliness level: ISO 4406 Class 18/13 or better. Refer to Danfoss publications *Fluids and Filtration* BLN-9887 or **520L0463** and *Design Guidelines for Selecting and Maintaining the Required Hydraulic Fluid Cleanliness 520L0465*. See *Fluid and filter maintenance*, page 17 for recommended fluid and filter change intervals.

¹ Hydraulic fluid viscosity must be maintained within the prescribed limits.

² As measured at the hottest point in the system, e.g. drain line.

Features

Auxiliary Mounting Pads

Auxiliary mounting pads are available for all radial ported Series 45 pumps. These pads are typically used for mounting auxiliary hydraulic pumps.

Since the auxiliary pad operates under case pressure, an O-ring must be used to seal the auxiliary pump mounting flange to the pad. The drive coupling is lubricated by oil from the main pump case. For details refer to *Series 45 J Frame Axial Piston Open Circuit Pumps Technical Information, 520L0676*.

Auxiliary pad options

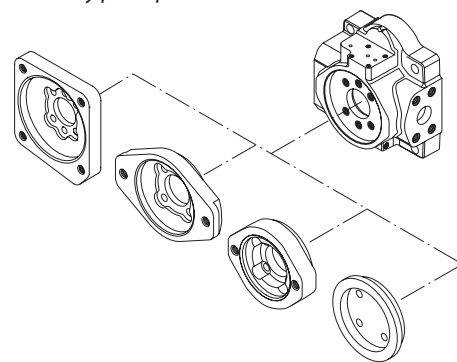

Input Shafts

Series 45 J frame pumps are available with a variety of splined, straight keyed, and tapered end shafts. For information on shafts refer to *Series 45 J Frame Axial Piston Open Circuit Pumps Technical Information, 520L0676*.

Features (continued)

Control Options

The Series 45 Frames J have three possible general control options, a Load Sensing (LS) control with Pressure Compensator (PC), a PC only control, or an electric control.

Operation

The bias spring (1) pushes against the servo piston (2) which pulls the swashplate (3) to max angle causing the pump to stroke. Internal pressure on the servo piston acts against the bias spring to reduce the swashplate angle causing the pump to destroke. Swashplate angle determines pump outlet flow. The pump control, depending on conditions in the system circuit, sets swashplate angle by metering system pressure to the servo piston.

Cross-section pump

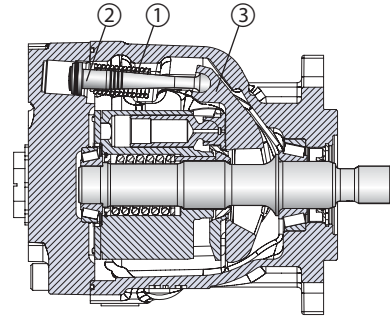

P104 360

Bias spring and servo piston set swashplate position

PC control

The PC control design maintains a constant pressure in the hydraulic circuit as flow varies. The PC control modulates pump flow accordingly to maintain system pressure at the PC setting as the PC adjusting plug (4) and spring (5) defines.

Cross-section PC control

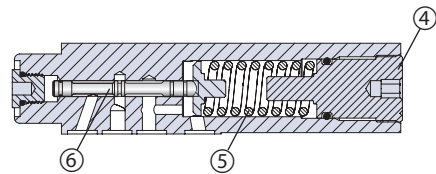

P104 049

PC spool shifts to port system pressure to servo piston

When system pressure, acting on the non-spring end of the PC spool (6), overcomes the force of the PC spring, the spool shifts porting system pressure to the servo piston and the swashplate angle decreases. When system pressure drops below the PC setting, the PC spring shifts the spool in the opposite direction connecting the servo piston to pump case and the swashplate angle increases. The swashplate is maintained at whatever angle is required to keep system pressure at the PC setting.

Features (continued)

Control Options (continued)

LS control

The LS control design matches pump flow with system demand. The LS control senses the flow demand of the system as a pressure drop across the **External Control Valve (ECV)**. As the ECV opens and closes, the pressure delta across the valve changes. When opening, the delta decreases. When closing, the delta increases. The LS control then increases or decreases pump flow to the system until the pressure delta becomes equal to the LS setting as defined by the LS adjusting plug (7) and spring (8).

Typical load-sensing control valve

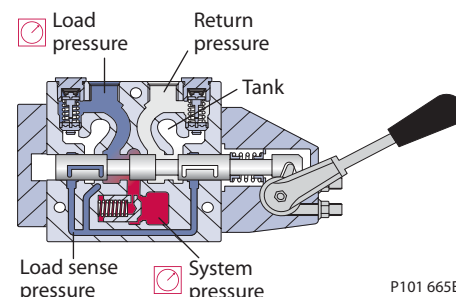

P101 665E

Pressure drop across external control valve defines system demand

The LS control consists of two spool valves that connect the servo piston either to pump case or system pressure. The PC spool (6) controls the pressure-compensating function of the control as previously described. The LS spool (9) controls the load-sensing function. The PC spool has priority over the LS spool.

Cross-section LS control

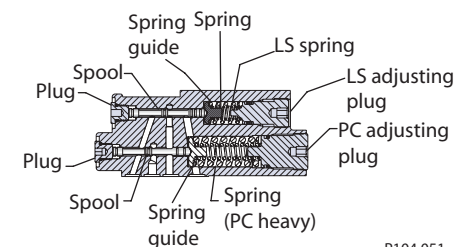

P104 051

LS spool shifts to port system pressure to servo piston

Through internal porting, system pressure (upstream of ECV) is applied to the non-spring end of the LS spool, and through hydraulic line connected at port X, LS pressure (downstream of ECV) is applied to the spring end. This arrangement allows the LS spool to act on the delta between system pressure and LS pressure. The LS spring sets the threshold of operation (LS setting).

Because the swashplate is biased to maximum angle, the pump attempts to deliver full flow to the hydraulic system. When the flow being delivered exceeds demand, the pressure delta across the ECV is great enough to overcome spring force and shift the LS spool porting system pressure to the servo piston. The pump de-strokes reducing flow until the delta across the ECV becomes equal to the LS setting. When flow being delivered is less than demand, the delta across the ECV drops below the LS setting and the LS spring shifts the spool connecting the servo piston to pump case. The pump strokes increasing flow until the delta across the ECV becomes equal to the LS setting.

When the external control valve is placed in neutral, it connects the LS signal line to drain. With no LS pressure acting on the non-spring end of the LS spool, the pump adjusts stroke to whatever position necessary to maintain system pressure at the LS setting. The pump is now in standby mode.

Because of the series arrangement of the LS and PC spools, the PC spool will override the LS spool. If at any time system pressure reaches the PC setting, the PC spool will shift blocking the passage that connects the LS spool with the servo piston and porting system pressure to the servo piston causing the pump to destroke.

Features (continued)

Control Options (continued)

Electric Proportional Controls

PLUS+1 Compliance

All Series 45 Electric controls have met and passed the Danfoss PLUS+1 compliance standard testing, and as such, this Series 45 control is PLUS+1 compliant. PLUS+1 compliance blocks are available on the Danfoss website, within the PLUS+1 Guide section.

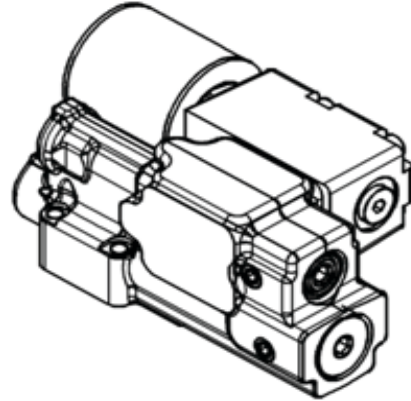

Electric Proportional Control Principle

The Electric Proportional Control consists of a proportional solenoid integrated into a Remote Pressure Compensated control. This control allows the pump to be operated at any pressure limit between the Load Sense and Pressure Compensation settings by varying the current sent to the solenoid.

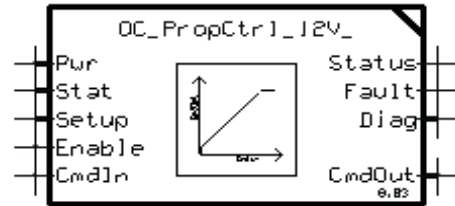

Electric On/Off Controls

PLUS+1 Compliance

All Series 45 Electric controls have met and passed the Danfoss PLUS+1 compliance standard testing, and as such, this Series 45 control is PLUS+1 compliant. PLUS+1 compliance blocks are available on the Danfoss website, within the PLUS+1 Guide section.

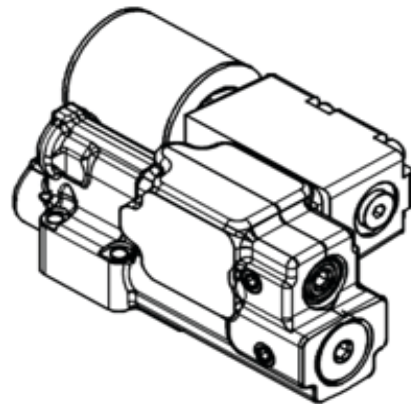

Electric On-Off Control Principle

The Electric On/Off Control consists of an On/Off solenoid integrated into a Remote Pressure Compensated control. This control allows the pump to be operated at either the Load Sense pressure setting when "On", or the Pressure Compensation pressure setting when "Off".

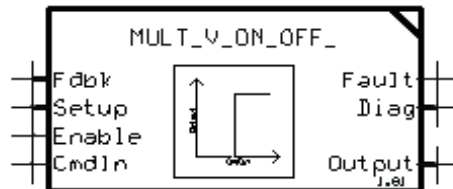

Pressure measurement

Required Tools

The service procedures described in this manual can be performed using common mechanic's hand tools. Special tools, if required are shown. Calibrate pressure gauges frequently to ensure accuracy. Use snubbers to protect gauges.

Port Locations and Gauge Installation

The illustration below shows gauge port locations. Recommended pressure gauges and fittings are in the table.

Gauge and port information

Port	Purpose	Range of gauge	Fitting
M1	System pressure	0-300 bar [0-5000 psi]	9/16 - 18 O-ring fitting
L1, L2	Case drain port	0-10 bar [0-100 psi]	7/8 - 14 O-ring fitting
X	LS signal	0-300 bar [0-5000 psi]	7/16 - 20 O-ring fitting (tee into LS signal line)

Gauge port locations

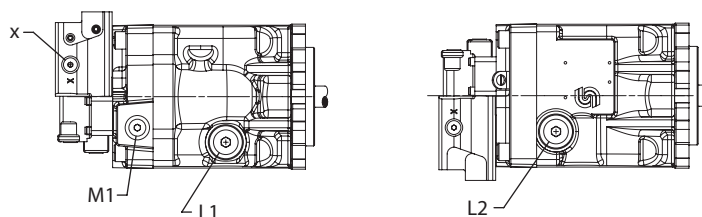

P104 364

Install Start-up Procedures

General

Follow this procedure when starting-up a new Series 45 installation or when restarting an installation in which the pump has been removed.

⚠ Warning

Unintended movement of the machine or mechanism may cause injury to the technician or bystanders. To protect against unintended movement, secure the machine or disable / disconnect the mechanism while servicing.

Prior to installing the pump, inspect for damage incurred during shipping. Make certain all system components (reservoir, hoses, valves, fittings, heat exchanger, etc.) are clean prior to filling with fluid.

Start-up Procedure

⚠ Caution

Incorrect shaft alignment may result in damage to drive shaft, bearings, or seal which can cause external oil leakage.

1. Connect the pump to the prime mover. Ensure that pump shaft is properly aligned with the shaft of the prime mover. ⚠
2. Fill the reservoir with recommended hydraulic fluid. Always filter fluid through a 10 micron filter pouring into the reservoir. Never reuse hydraulic fluid.
3. Fill the main pump housing with clean hydraulic fluid. Pour filtered oil directly into the upper most case drain port.
4. Fill the inlet line leading from the pump to the reservoir. Check the inlet line for properly tightened fittings and be certain it is free of restrictions and air leaks.
5. To ensure the pump stays filled with oil, install the case drain line in the upper most case drain port.
6. Install a gauge at port M1 to monitor system pressure during start up.

Follow recommendations in the vehicle/machine operator's manual for prime mover start up procedures.

7. While watching the pressure gauge installed at M1, jog the prime mover or run at the lowest possible speed until system pressure builds to normal levels (minimum 11 bar [160 psi]). Once system pressure is established, increase to full operating speed. If system pressure is not maintained, shut down the prime mover, determine cause, and take corrective action. Refer to *Troubleshooting*, page 18.
8. Operate the hydraulic system for at least fifteen minutes under light load conditions.
9. Check and adjust control settings as necessary after installation. Refer to *Adjustments*, page 21.
10. Shut down the prime mover and remove the pressure gauge. Replace plug at port M1.
11. Check the fluid level in the reservoir; add clean filtered fluid if necessary.
12. The pump is now ready for operation.

Fluid and Filter Maintenance**Recommendations**

To ensure optimum life of Series 45 products, perform regular maintenance of the fluid and filter. Contaminated fluid is the main cause of unit failure. Take care to maintain fluid cleanliness when servicing.

Check the reservoir daily for proper fluid level, the presence of water, and rancid fluid odor. Water in the fluid may be noted by a cloudy or milky appearance or free water in the bottom of the reservoir. Rancid odor indicates the fluid has been exposed to excessive heat. Change the fluid immediately if these conditions occur. Correct the problem immediately.

Change the fluid and filter per the vehicle/machine manufacturer's recommendations or at these intervals:

Fluid and filter change interval

Reservoir type	Maximum change interval
Sealed	2000 hours
Breather	500 hours

Change the fluid more frequently if it becomes contaminated with foreign matter (dirt, water, grease, etc.) or if the fluid is subjected to temperature levels greater than the recommended maximum.

Dispose of used hydraulic fluid properly. Never reuse hydraulic fluid.

Change filters whenever the fluid is changed or when the filter indicator shows that it is necessary to change the filter. Replace all fluid lost during filter change.

Troubleshooting

Excessive Noise and/or Vibration

Item	Description	Action
Check fluid level in reservoir.	Insufficient hydraulic fluid causes cavitation.	Fill the reservoir to proper level.
Check for air in system.	Air in system causes noisy, erratic control.	Purge air and tighten fittings. Check inlet for leaks.
Check pump inlet pressure/vacuum.	Improper inlet conditions cause erratic behavior and low output flow.	Correct pump inlet pressure / vacuum conditions. Refer to <i>Hydraulic parameters</i> , page 10.
Inspect shaft couplings.	A loose or incorrect shaft coupling causes excessive noise and/or vibration.	Repair or replace coupling and ensure that correct coupling is used.
Check shaft alignment.	Misaligned shafts create excessive noise and/or vibration.	Correct shaft misalignment.
Hydraulic fluid viscosity above acceptable limits.	Hydraulic fluid viscosity above acceptable limits or low fluid temperature will not allow the pump to fill or control to operate properly.	Allow system to warm up before operating, or use fluid with the appropriate viscosity grade for expected operating temperatures. See <i>Hydraulic Fluids and Lubricants Technical Information Manual, 520L0463</i> .

Actuator Response is Sluggish

Item	Description	Action
Check external system relief valve setting.	Low external relief valve setting slows down system.	Adjust external relief valve setting following manufacturer's recommendations. External relief setting must be above PC setting to operate properly.
Check PC and LS control setting.	Low PC setting prevents the pump from achieving full stroke. Low LS setting limits output flow.	Adjust PC and LS setting. Refer to <i>Adjustments</i> , page 21
Check LS control signal pressures.	Incorrect LS signal will not allow pump to operate correctly.	Inspect system to ensure that proper LS signal transmit to pump.
Internal system leaks.	Worn internal parts don't allow the pump to operate properly.	Refer to Authorized Service Center for required repair.
Hydraulic fluid viscosity above acceptable limits.	Hydraulic fluid viscosity above acceptable limits or low fluid temperature will not allow the pump to fill or control to operate properly.	Allow system to warm up before operation or use fluid with the appropriate viscosity grade for expected operating temperatures. See <i>Hydraulic Fluids and Lubricants Technical Information Manual, 520L0463</i> .
Check external system valving.	Malfunctioning valving may not allow system to respond properly.	Repair or replace system valving as required.
Check pump case pressure.	High case pressure causes the system to be sluggish.	Correct case drain line restrictions.
Check pump inlet pressure/vacuum.	High inlet vacuum causes low output flow.	Correct inlet pressure conditions.

**Troubleshooting
(continued)**

System Operating Hot

Item	Description	Action
Check fluid level in reservoir.	Insufficient volume of hydraulic fluid will not meet cooling demands of system.	Fill reservoir to proper level. Verify proper size of reservoir.
Inspect heat exchanger. Check air flow and input air temperature for the heat exchanger.	Insufficient air flow, high input air temperature, or undersized heat exchangers will not meet cooling demands of the system.	Clean, repair, or replace heat exchanger as required. Verify proper size of heat exchanger.
Check external system relief valve setting.	Fluid passing through relief valve adds heat to system.	Adjust external system relief valve setting following manufacturer's recommendations. External relief valve setting must be above PC setting for proper operation.
Check pump inlet pressure/vacuum.	High inlet vacuum adds heat to system.	Correct inlet pressure/vacuum conditions.

Low Pump Output Flow

Item	Description	Action
Check fluid level in reservoir.	Insufficient hydraulic fluid will limit output flow and cause internal damage to pump.	Fill the reservoir to proper level.
Hydraulic fluid viscosity above acceptable limits.	Fluid viscosity above acceptable limits or low fluid temperature will not allow the pump to fill or control to operate properly.	Allow system to warm up before operating, or use fluid with the appropriate viscosity grade for expected operating temperatures. See <i>Hydraulic Fluids and Lubricants Technical Information Manual, 520L0463</i> .
Check external system relief valve setting.	External relief valve set below PC setting causes low output flow.	Adjust external relief valve following manufacturer's recommendation. External relief valve setting must be above PC setting to operate properly.
Check PC and LS control setting.	Low PC setting prevents the pump from achieving full stroke.	Adjust PC and LS setting. Refer to <i>Adjustment</i> , page 21.
Check pump inlet pressure/vacuum.	High inlet vacuum causes low output flow.	Correct inlet pressure conditions.
Check input speed.	Low input speeds decrease flow.	Adjust input speed.
Check pump rotation.	Incorrect rotational configuration causes low flow.	Use pump with appropriate rotational configuration.

Pressure or Flow Instability

Item	Description	Action
Check for air in system.	Air in system causes erratic operation.	Activate PC allowing system to bleed air. Check inlet line for leaks and eliminate source of air ingress.
Check control spools.	Sticking control spools cause erratic operation.	Inspect spools for free movement in bore. Clean or replace.

**Troubleshooting
(continued)**

**Pressure or Flow Instability
(continued)**

Item	Description	Action
Check LS setting.	Low LS setting may cause instability.	Adjust LS setting to proper level. See <i>Adjustments</i> , page 21.
Check LS signal line.	Blocked LS signal line interferes with proper LS operation.	Remove blockage.
Check external relief valve and PC setting.	Insufficient pressure differential between PC setting and external relief valve.	Adjust external relief valve or PC control settings to appropriate level. Relief valve setting must be above PC setting to operate properly.
Check external relief valve.	Chattering external relief valve may cause unstable feedback to pump control.	Adjust or replace relief valve.

System Pressure not Reaching PC Setting

Item	Description	Action
Check PC control setting.	System pressure will not rise above PC setting.	Adjust PC to appropriate setting. Refer to <i>Adjustments</i> , page 21.
Check external relief valve.	External relief valve setting below PC setting presents pressure compensation.	Adjust external relief valve according to manufacturer's recommendations. External relief valve must be set above PC setting to operate properly.
Inspect PC control spring.	Broken, damaged, or missing spring will cause erratic operation.	Replace the spring as required.
Inspect PC spool for wear.	Wear of PC spool causes internal leakage in the control.	Replace the spool as required.
Inspect PC spool for proper orientation.	Improper orientation results in poor operation.	Correct orientation of spool.
Check PC control for contamination.	Contamination may interfere with movement of the PC spool.	Clean PC control components, take appropriate action to eliminate contamination.

High Inlet Vacuum

Caution
High inlet vacuum causes cavitation which can damage internal pump components.

Item	Description	Action
Check fluid temperature.	Low temperature increases viscosity. High fluid viscosity causes high inlet vacuum.	Allow system to warm up before operating.
Inspect inlet screen.	Blocked or restricted inlet screen causes high inlet vacuum.	Clean screen/remove blockage.
Check inlet piping.	Too many fittings, bends, or long piping causes high inlet vacuum.	Eliminate fittings to make path more direct.
Hydraulic fluid viscosity above acceptable limits.	High fluid viscosity causes high inlet vacuum.	Select fluid with appropriate viscosity for expected operating temperature. See <i>Hydraulic Fluids and Lubricants Technical Information Manual</i> , 520L0463.

Adjustments

PC Control

PC setting is indicated in the pump model code. Refer to the *Series 45 J Frame Open Circuit Axial Piston Pumps Technical Information Manual, 520L0676*, for more information.

⚠ Warning

Escaping hydraulic fluid under pressure can have sufficient force to penetrate your skin causing serious injury and/or infection. Relieve pressure in the system before removing hoses, fittings, gauges, or components.

Unintended movement of the machine or mechanism may cause injury to the technician or bystanders. To protect against unintended movement, secure the machine or disable/disconnect the mechanism while servicing.

⚠ Caution

Contamination can damage internal components and void the manufacturer's warranty. Take precautions to ensure system cleanliness when removing and reinstalling system lines.

Before performing adjustments, read page 15, *Pressure measurement*.

1. Install a pressure gauge in port M1 to measure system pressure. Install a pressure gauge in case drain port L1 or L2 to measure case pressure. ⚠
2. Start the prime mover and allow fluid to reach normal operating temperature. Operate a hydraulic function to its full extension, loading the pump at maximum pressure and zero flow.
3. Loosen the PC set screw and turn the PC adjusting plug until the desired setting is indicated on the pressure gauge at port M1¹. Clockwise rotation increases pressure, counterclockwise rotation decreases; approximate gain 42 bar [610 psi] per turn.

If the pressure does not increase, an external system relief valve may require adjustment. External system relief valve must be set above the PC setting for proper operation.

4. While holding the position of the PC adjusting plug, torque the PC set screw to 7.5 - 10.8 N•m [5.5 - 8 lbf•ft].
5. Stop the prime mover, remove the pressure gauges, and return the system to its normal operating configuration.

PC control adjustment

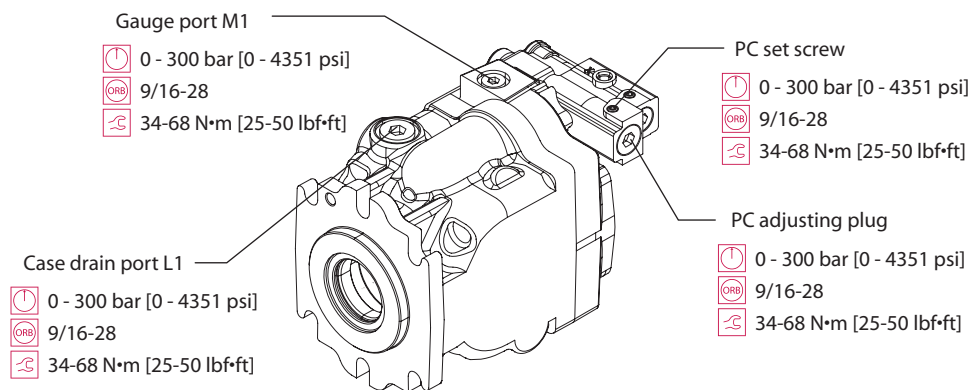

P104 365E

Pressure change

	Control option	PC adjustment	LS adjustment
J Frame	LS, LD, LB, LE, PC, RP	42 bar/rev [609 PSI/rev]	17.2 bar/rev [250 PSI/rev]
	BB, BC, BP, BS	36 bar/rev [534 PSI/rev]	
	AB, AC, AD, AJ, AS	8.5 bar/rev [123 PSI/rev]	

¹ PC setting is referenced to case pressure. Subtract case pressure from system pressure to compute the actual setting.

Adjustment (continued)

LS Control

The LS setting is indicated in the pump model code. Refer to the *Series 45 J Frame Open Circuit Axial Piston Pumps Technical Information Manual, 520L0676*, for more information.

Warning

Escaping hydraulic fluid under pressure can have sufficient force to penetrate your skin causing serious injury and/or infection. Relieve pressure in the system before removing hoses, fittings, gauges, or components.

Unintended movement of the machine or mechanism may cause injury to the technician or bystanders. To protect against unintended movement, secure the machine or disable/disconnect the mechanism while servicing.

If the pressure does not increase, an external system relief valve may require adjustment. External system relief valve must be set above the PC setting for proper operation.

Before performing adjustments, read page 15, *Pressure measurement*.

1. Install a pressure gauge in port M1 to measure system pressure. Install a pressure gauge in drain port L1 or L2 to measure case pressure. Tee-in a gauge to the LS/remote PC signal line (port X).
Warning
2. Start the prime mover and allow fluid to reach normal operating temperature. Slowly operate a hydraulic function that will demand approximately half flow from the pump, but keep system pressure below the PC set point.
3. Loosen the LS set screw. While watching the pressure gauges, turn the LS adjusting plug until the desired pressure differential between port M1 and port X is achieved¹. Clockwise rotation increases the setting, counterclockwise rotation will decrease it; approximate gain = 17 bar [250 psi] per turn.
4. While holding the position of the LS adjusting plug, torque the LS set screw to 7.5 - 10.8 N•m [5.5-8 lbf•ft].
5. Operate a hydraulic function to its full extension loading the pump at maximum pressure and zero flow.
6. Loosen the PC set screw and turn the PC adjusting plug until the desired setting is indicated on the pressure gauge at port M1². Clockwise rotation increases pressure, counterclockwise rotation decreases it; approximate gain = 42 bar [610 psi] per turn.
7. While holding the position of the PC adjusting plug, torque the PC set screw to 7.5 - 10.8 N•m [5.5-8 lbf•ft].
8. Stop the prime mover, remove the pressure gauges, and return the system to its normal operating configuration.

Caution

Contamination can damage internal components and void the manufacturer's warranty. Take precautions to ensure system cleanliness when removing and reinstalling system lines.

LS control adjustment

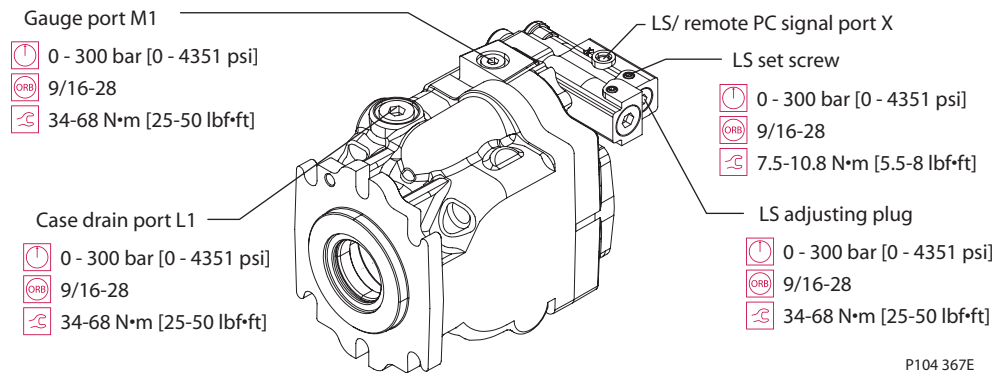

¹ The LS setting is a differential pressure. Subtract pilot pressure at port X from system pressure at port M1 to compute the actual setting.

² PC setting is referenced to case pressure. Subtract case pressure from system pressure to compute the actual setting.

Minor Repair

Shaft Seal Replacement

The Series 45 open circuit variable pumps use a lip-type shaft seal. You can replace this seal without major disassembly of the unit. Replacing the shaft seal requires removing the pump from the machine.

Removal

1. Using the appropriate snap-ring pliers, remove the retaining ring (K010) from the housing.

2. Remove the shaft seal (K020) from the bore in the pump housing and discard. **!**

Remove second seal if pump is so equipped. See illustration below.

3. Puncture the face of the seal with a packing hook, or use a slide-hammer type puller to remove the seal.

Shaft seal and retaining ring

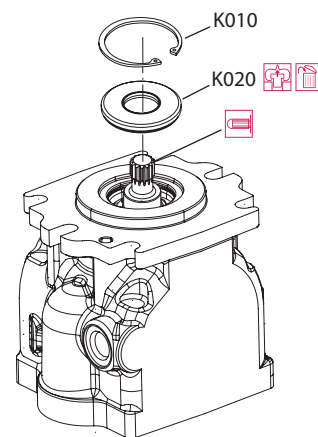

E101 187

! Caution
Don't damage the pump housing or shaft.

Installation

4. Inspect the pump housing and new seal for damage. Inspect the sealing area on the shaft for rust, wear, or contamination. Polish the sealing area on the shaft if necessary.

5. Lubricate the lip of the new shaft seal with clean hydraulic fluid. Place a protective sleeve over the shaft end to prevent damage to the seal during installation.

6. Keeping the seal perpendicular to the shaft, press the new seal into the housing just far enough to clear the retaining ring groove. **!** Install seal with the cupped side toward the shaft bearing. Do not damage the seal during installation.

Install second seal if pump is so equipped. See illustration below.

7. Using the appropriate snap ring pliers, install the seal retaining ring.

8. Remove the installation sleeve.

Double seal and retaining ring

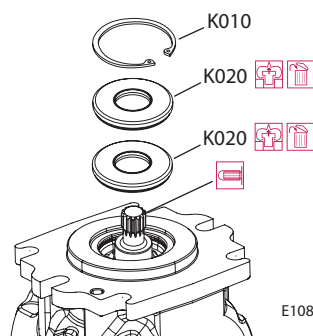

E108 672E

! Caution
Premature bearing failure can result if the shaft seal contacts the shaft bearing.
Press the seal into the housing only far enough to clear the retaining ring groove.

Minor Repair

Auxiliary pads

You may install auxiliary mounting pads on pumps equipped with through-drive radial ported endcaps. Follow these steps to either remove, replace, or exchange auxiliary mounting pads.

Removal

1. Remove the screws (J130), retaining the cover plate (J110) or auxiliary pump (not shown). Remove the shipping cover or auxiliary pump and its seal (J120).
2. Remove the drive coupling (J140) if present.
3. Remove the 4 screws (J100) retaining the pad adapter (J080) to the endcap. Discard the pad adapter O-ring (J090) if present. Also discard the J095 O-ring.

Auxiliary mounting pads

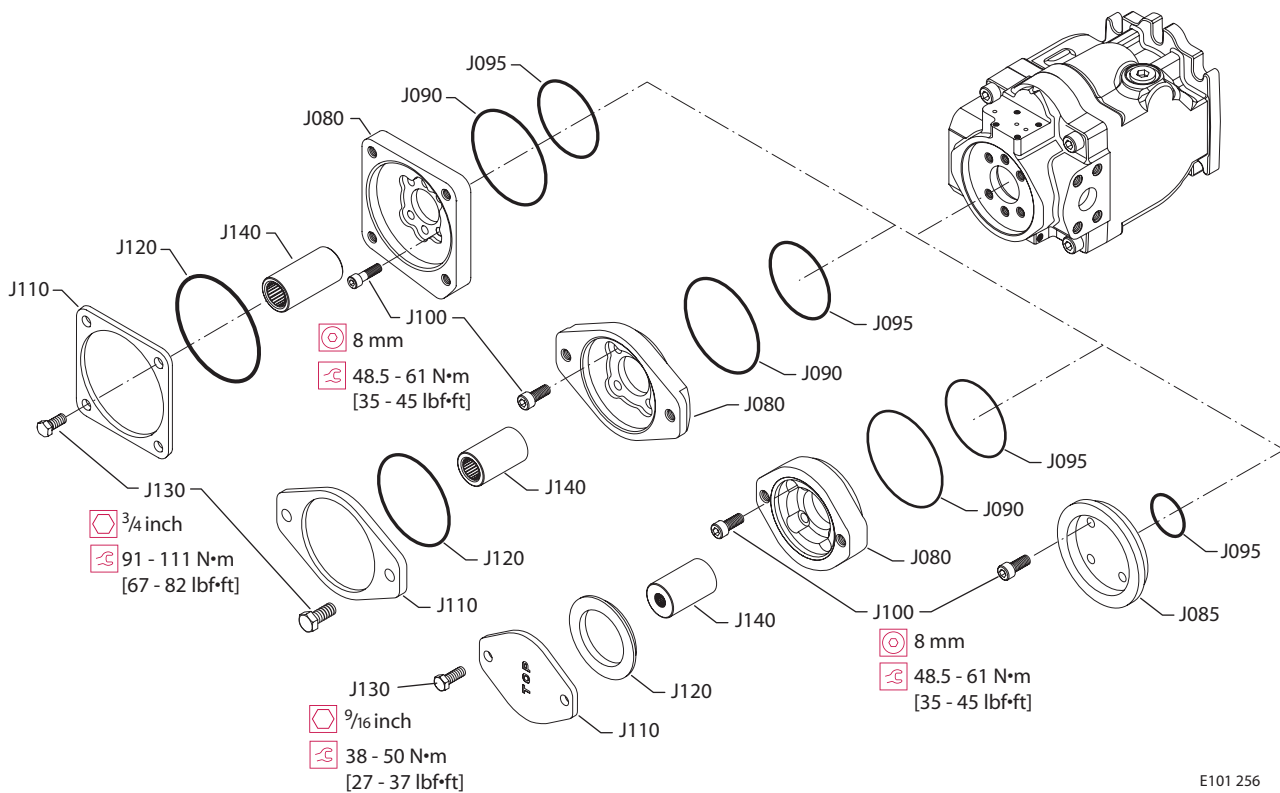

Installation

4. Lubricate new O-ring (J090) with petroleum jelly. Install the pad adapter to the endcap.
5. Install the 4 screws (J100) and torque to 48.5 - 61 N•m [35 - 45 lbf•ft].
6. Install the drive coupling (J140) if present.
7. Install shipping cover or auxiliary pump with seal (J120).
8. Install the screws (J130) and torque to 94 - 115 N•m [67 - 82 lbf•ft]. If you have an auxiliary A pad, install the screws (J130) and torque to 37 - 50 N•m [27 - 37 lbf•ft].

Caution
Shipping cover is intended only to retain coupling during shipment and storage. Do not operate pump with coupling and shipping cover installed.

Minor Repair (continued)

LS and PC Controls

Disassembly

1. Remove the 4 screws (C300) holding the control housing onto the end cap.
2. Remove the control and discard the 4 interface O-rings (C200).
3. Remove the PC set screw (C102), PC adjusting plug (C138), O-ring (C138A), springs (C134, C135), and seat (C133). Discard the O-ring.
4. Remove the plug (C103), O-ring (C103A), and PC spool (C132) from the control housing. Discard the O-ring. Note orientation of the spool for reassembly.

For PC only controls, skip steps 5 through 7

5. Remove the plug (C105) and O-ring (C105A), or the plug (C106) and O-ring (C106A). Discard the O-ring (C105A or C106A).
6. Remove the LS set screw (C102), LS adjusting plug (C118), O-ring (C118A), back-up rings (C118B), springs (C114, C115), and seat (C113). Discard the C118A O-ring.
7. Remove the C104 plug, C104A O-ring, and C112 LS spool from the control housing; discard the O-ring. Note orientation of the spool for reassembly.

Control assembly

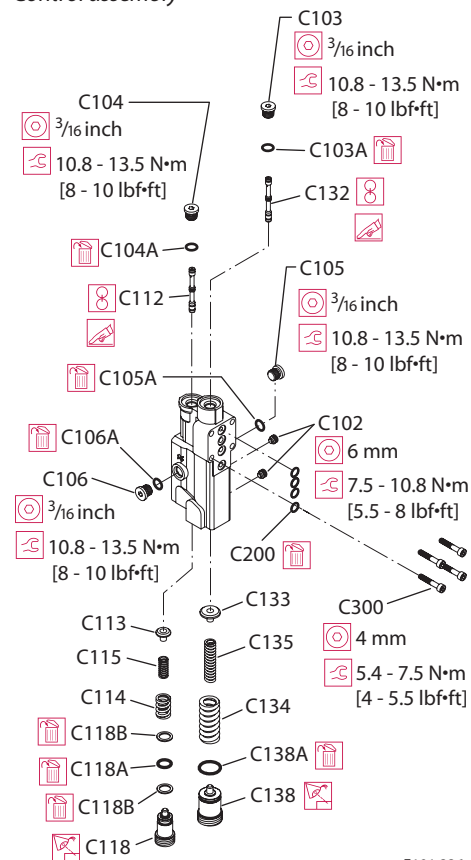

E101 226

LS control shown; parts C104 through C106 and C112 through C118 are not used on PC control

Inspection

8. Inspect the adjusting plugs for wear at the tips and where they contact the springs; replace as necessary.
9. Inspect the springs and spring guides for wear or damage; replace as necessary.
10. Carefully inspect the spools. Ensure the sealing lands are free of nicks and scratches. Check the ends that contact the spring guides for wear. Replace spools as necessary.
11. Inspect the control housing for damage. Check the spool bores for excessive wear.
12. Clean all parts and lubricate spools, springs, guides and new O-rings with clean hydraulic fluid.

Minor Repair (continued)

LS and PC Controls (continued)

Reassembly

13. Install the PC spool (C132), spherical end first, into the PC bore. Using a new O-ring (C103A), install the plug (C103). Torque the plug (C103) to 10.8 - 13.5 N•m [8 - 10 lbf•ft].
14. Place the two PC springs (C134, C135) onto the spring guide (C133) and install into the PC bore. Place a new O-ring (C138A) onto the PC adjusting screw and thread it into the PC bore until flush, then make another full turn. Install and torque the PC set screw (C102) to 7.5 - 10.8 N•m [5.5-8 lbf•ft].

For PC only controls, skip steps 15 through 17.

15. Install the LS spool (C112), spherical end first, into the LS bore. Using a new O-ring (C105A or C106A), install the plug (C105 or C106). Torque the plug (C105 or C106) to 10.8 - 13.5 N•m [8 - 10 lbf•ft].
16. Using a new O-ring (C104A), install the plug (C104). Torque the plug to 10.8 - 13.5 N•m [8 - 10 lbf•ft].
17. Place the two LS springs (C114, C115) onto the spring guide (C113) and install into the LS bore. Place a new O-ring (C118A) and back-up rings (C118B) onto the LS adjusting screw and thread it into the LS bore until flush, then make another full turn. Install and torque the LS set screw (C102) to 7.5 - 10.8 N•m [5.5-8 lbf•ft]

18. Using petroleum jelly to retain them, install the 4 interface O-rings (C200) in the recesses on the control housing.

19. Install the control assembly onto the endcap using the 4 screws (C300). Torque the screws to 5.4 - 7.5 N•m [4 - 5.5 lbf•ft]. Torque screws in a criss-cross pattern and re-torque the first screw to ensure proper torque retention.

20. Check and adjust the control setting. See *Adjustments*, page 21

Control assembly

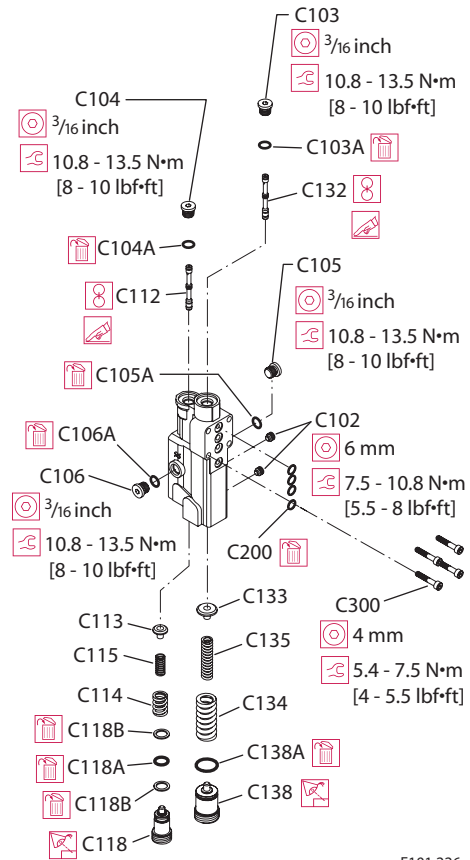

E101 226

LS control shown; parts C104 through C106 and C112 through C118 are not used on PC control

Minor Repair (continued)

Electric Controls

Disassembly

1. Remove four screws (C300).
2. Remove the control and discard the four O-rings (C200).
3. Remove set screws (C102), PC adjusting plug (C138) with O-ring (C138A), springs (C134, C135), and seat (C133). Discard the O-ring if it is damaged.
4. Remove plug (C103). Remove PC spool (C132). Note orientation of the spool for reassembly.
5. Remove plug (G030), and orifice (G020).
6. Remove LS adjusting plug (C118), springs (C114, C115), and seat (C113).
7. Remove plug (C104), and spool (C112). Note the orientation of the spool for reassembly.
8. Remove four screws (C151). Remove the manifold (C152) and discard the two interface O-rings (C154).
9. For electric proportional controls only:
Remove the electric control manifold drain orifice (C149).
10. Remove plug (C153). Remove the cartridge valve nut (C125), electric solenoid (C155), and cartridge valve (C150) from the electric control manifold.

Control assembly

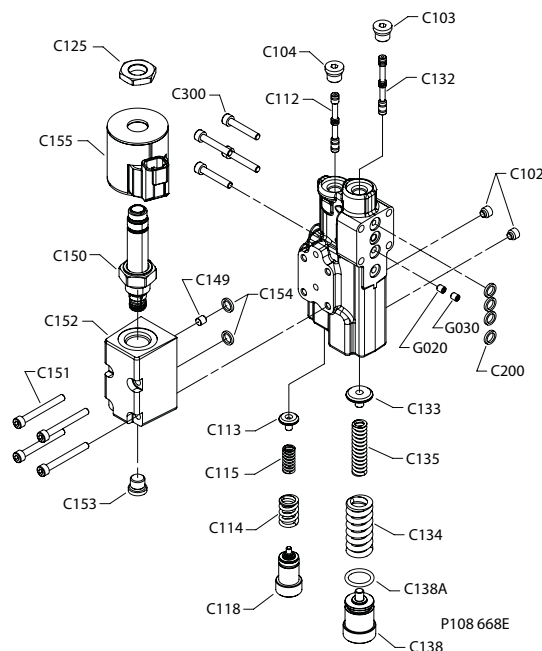

Inspection

1. Inspect the adjusting plugs for wear at the tips and where they contact the springs; replace as necessary.
2. Inspect the springs and spring guides for wear or damage; replace as necessary.
3. Carefully inspect the spools. Ensure the sealing lands are free of nicks and scratches. Check the ends that contact the spring guides for wear. Replace spools as necessary.
4. Inspect the control housing for damage. Check the spool bores for excessive wear.
5. Remove debris from orifices if necessary. Ensure the servo control orifice backup plug is clean, and remove debris if necessary.
6. Clean all parts and lubricate spools, springs, guides and new O-rings with clean hydraulic fluid.

Minor Repair (continued)**Electric Controls
(continued)****Reassembly**

1. Install the servo control orifice (G020), and torque to 2-3.4 N•m [18-30 in•lb]. Then install the orifice backup plug (G030), and torque to 2-3.4 N•m [18-30 in•lb].
2. Install the PC spool (C132), spherical end first, into the PC bore. Install plug (C103). Torque the plug to 10.8 - 13.5 N•m [8 - 10 lbf•ft].
3. Place the two PC springs (C134, C135) onto the spring guide (C133) and install into the PC bore. Place a new O-ring (C138A) onto the PC adjusting screw (C138) and thread it into the PC bore until flush, then make another full turn. Install and torque the PC set screw (C102) to 7.5 - 10.8 N•m [5.5-8 lbf•ft].
4. Install the LS spool (C112), spherical end first, into the LS bore.
5. Install plug (C104). Torque the plug to 10.8 - 13.5 N•m [8 - 10 lbf•ft].
6. Place the two LS springs (C114, C115) onto the spring guide (C113) and install into the LS bore. Thread adjusting screw (C118) into the LS bore until flush, then make another full turn. Install and torque the LS set screw (C102) to 7.5 - 10.8 N•m [5.5-8 lbf•ft].
7. Install the electric control manifold drain orifice (C149) and torque to 2-3.4 N•m [18-30 in•lb].
8. Install the cartridge valve (C150) into the electric control manifold (C152). Torque to 25.8-28.5 N•m [19-21 lbf•ft]. DO NOT OVERTORQUE the cartridge valve.
9. Install the electric solenoid (C155), and solenoid coil nut (C125). Torque to 6.8-9.5 N•m [5-7 lbf•ft]
10. Install plug (C153). Torque the plug to 10.8 - 13.5 N•m [8 - 10 lbf•ft].
11. Using petroleum jelly to retain them, install the two interface O-rings (C154) in the recesses on the electric control manifold.
12. Install the manifold assembly onto the control housing using four screws (C151). Torque the screws to 5.4 - 7.5 N•m [4 - 5.5 lbf•ft]. Torque the screws in a criss-cross pattern and re-torque the first screw to ensure proper torque retention.
13. Using petroleum jelly to retain them, install the four interface O-rings (C200) in the recesses on the control housing.
14. Install the control assembly onto the endcap using the four screws (C300). Torque the screws to 5.4 - 7.5 N•m [4 - 5.5 lbf•ft]. Torque screws in a criss-cross pattern and re-torque the first screw to ensure proper torque retention.
15. Check and adjust the control setting. See *Adjustments*, page 21-22.

Minor Repair (continued)

Servo Control Orifice

Disassembly

1. Remove four screws (C300).
2. Remove the control and discard the four O-rings (C200).
3. Remove PC plug (C103), and PC spool (C132) from the control housing.

Note the orientation of the spool for reassembly.

4. Remove backup plug (G030), and orifice (G020).

Reassembly

1. Install the orifice (G020), and torque to 2-3.4 N•m [18-30 in•lb]. Then install the orifice backup plug (G030), and torque to 2-3.4 N•m [18-30 in•lb].
2. Install the PC spool (C132), spherical end first, into the PC bore. Install plug (C103). Torque the plug to 10.8 - 13.5 N•m [8 - 10 lbf•ft].
3. Using petroleum jelly to retain them, install the four O-rings (C200) in the recesses on the control housing.
4. Install the control assembly onto the endcap using four screws (C300). Torque the screws to 5.4 - 7.5 N•m [4 - 5.5 lbf•ft]. Torque screws in a criss-cross pattern and re-torque the first screw to ensure proper torque retention.

Control assembly

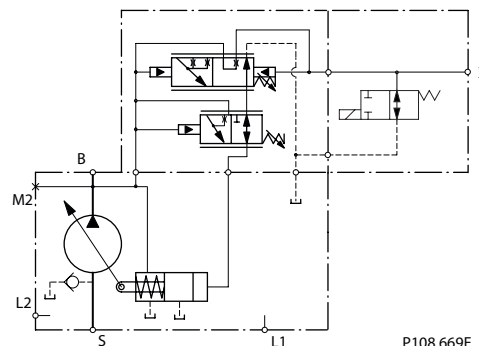

P108 669E

Minor Repair (continued)

Plug and fitting sizes and torques

If any plugs or fittings are removed from the unit during service, install and torque as indicated here. This drawing is a composite. Your configuration may differ but here is the appropriate wrench size and torque:

Plug locations, sizes, and torques

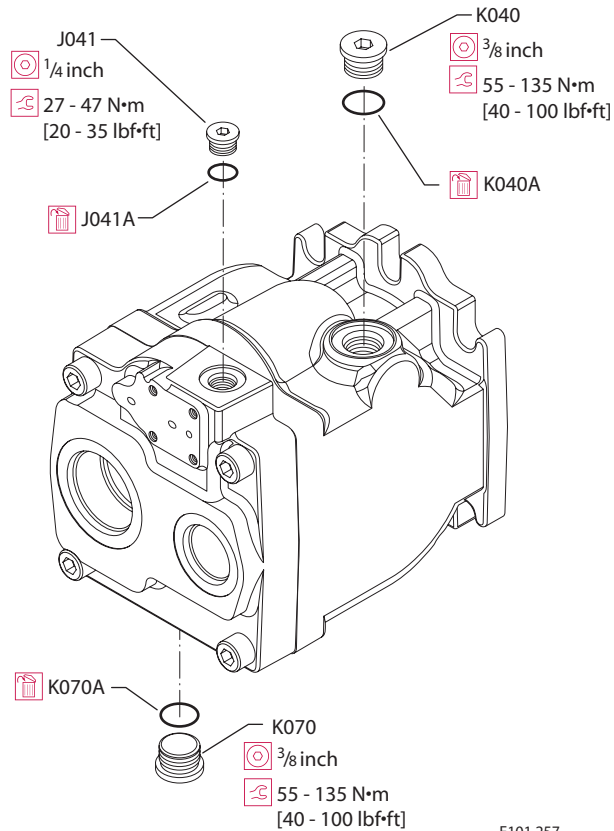

E101 257

Notes



Products we offer:

- Bent Axis Motors
- Closed Circuit Axial Piston Pumps and Motors
- Displays
- Electrohydraulic Power Steering
- Electrohydraulics
- Hydraulic Power Steering
- Integrated Systems
- Joysticks and Control Handles
- Microcontrollers and Software
- Open Circuit Axial Piston Pumps
- Orbital Motors
- PLUS+1® GUIDE
- Proportional Valves
- Sensors
- Steering
- Transit Mixer Drives

Danfoss Power Solutions is a global manufacturer and supplier of high-quality hydraulic and electronic components. We specialize in providing state-of-the-art technology and solutions that excel in the harsh operating conditions of the mobile off-highway market. Building on our extensive applications expertise, we work closely with our customers to ensure exceptional performance for a broad range of off-highway vehicles.

We help OEMs around the world speed up system development, reduce costs and bring vehicles to market faster.

Danfoss – Your Strongest Partner in Mobile Hydraulics.

Go to www.powersolutions.danfoss.com for further product information.

Wherever off-highway vehicles are at work, so is Danfoss.

We offer expert worldwide support for our customers, ensuring the best possible solutions for outstanding performance. And with an extensive network of Global Service Partners, we also provide comprehensive global service for all of our components.

Please contact the Danfoss Power Solution representative nearest you.

Comatrol

www.comatrol.com

Schwarzmueller-Inverter

www.schwarzmueller-inverter.com

Turolla

www.turollaocg.com

Valmova

www.valmova.com

Hydro-Gear

www.hydro-gear.com

Daikin-Sauer-Danfoss

www.daikin-sauer-danfoss.com

Local address:

Danfoss Power Solutions US Company

2800 East 13th Street
Ames, IA 50010, USA
Phone: +1 515 239 6000

Danfoss Power Solutions GmbH & Co. OHG

Krokamp 35
D-24539 Neumünster, Germany
Phone: +49 4321 871 0

Danfoss Power Solutions ApS

Nordborgvej 81
DK-6430 Nordborg, Denmark
Phone: +45 7488 2222

Danfoss Power Solutions

22F, Block C, Yishan Rd
Shanghai 200233, China
Phone: +86 21 3418 5200

Danfoss can accept no responsibility for possible errors in catalogues, brochures and other printed material. Danfoss reserves the right to alter its products without notice. This also applies to products already on order provided that such alterations can be made without subsequential changes being necessary in specifications already agreed. All trademarks in this material are property of the respective companies. Danfoss and the Danfoss logotype are trademarks of Danfoss A/S. All rights reserved.