

4 - Service

Warnings/Cautions

All warnings and cautions listed in this chapter are as follows:

- ! WARNING:** *All maintenance activities shall be performed by qualified personnel. Failure to do so could result in serious injury.*
- ! WARNING:** *Disconnect the power cord before beginning this procedure. Keep wet items away from inside parts of the unit. Electrical shock could occur even if the unit is unplugged.*
- ! WARNING:** *Flywheel may be hot. Wait until it cools before servicing.*
- ! CAUTION:** *Do not pinch your fingers between the belt and pulley during this procedure.*
- ! WARNING:** *Failure to release the drive belt tension may cause personal injury and may damage the unit.*
- ! WARNING:** *Do not touch components on the lower board. A charge can remain after unplugging the power cord and turning off the unit.*
- ! CAUTION:** *Pulley on eddy current brake is sharp. Wear work gloves to protect your hands.*

! WARNING: All maintenance activities shall be performed by qualified personnel. Failure to do so could result in serious injury.

For any service related concerns, call Cybox Customer Service at **800-766-3211** (for Cybox customers living within the USA). For customers living outside the USA, call **508-533-4300** or fax **508-533-5183**.

NOTE: Read and understand each procedure thoroughly before servicing. Unless otherwise noted “right” and “left” denote user orientation for all procedures.

! CAUTION

Use only Cybox replacement parts when servicing. Failure to do so could result in personal injury.

Test Mode

To enter **Test Mode** press and hold down the **Pause/end** key on the display while turning the power switch to the on (I) position. When all keys are released “ARC” and the software revision “x.xx” are shown on the display. To exit **Test Mode** press **Pause/end**.

Cybox will void warranty if non-Cybox replacement parts are used.

Stuck Key List

If **Test Mode** occurs without holding any keys, a key may be stuck closed or Error 7 may have occurred. You may need to replace the upper and/or lower display overlay. See Figure 1. If “KEY#” is displayed you can determine which key is stuck closed by referring to the number list below.

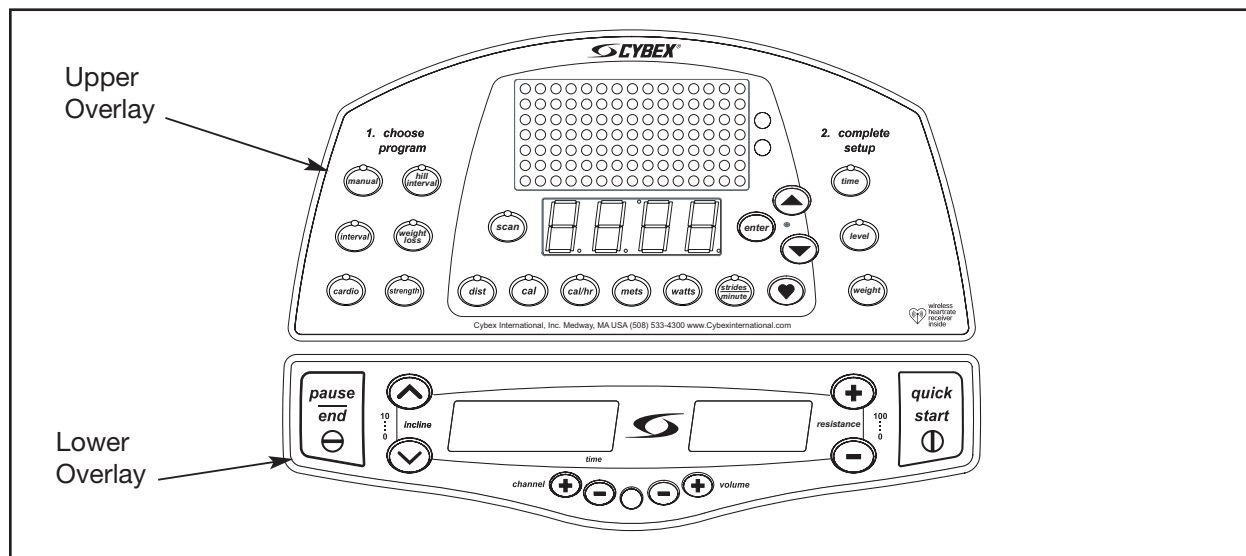

Figure 1

- | | | | |
|--------------|--------------------|------------------|-------------------|
| 1 Mets | 9 Incline Down | 17 Incline Up | 25 Pause/End |
| 2 Auxiliary | 10 Resistance Down | 18 Resistance Up | 26 Quick Start |
| 3 Channel Up | 11 Channel Down | 19 Volume Down | 27 Volume Up |
| 4 Scan | 12 Strength | 20 Center Up | 28 Hill Interval |
| 5 Watts | 13 Cal/Hr | 21 Cal | 29 Dist |
| 6 Cardio | 14 Interval | 22 Weight Loss | 30 Manual |
| 7 Level | 15 Time | 23 Weight | 32 Strides/Minute |
| 8 Enter | 16 Center Down | 24 Heart | |

LED Functions

LEDs are used to indicate the status of many of the unit inputs. After entering *Test Mode* refer to the following list to check that these LEDs are functioning properly:

Heart LED - Blinks on blue with every signal from the contact heart rate receiver and red for wireless signals (Polar).

Weight LED - Blinks on when CSAFE data is being received.

Level LED - Blinks on when CSAFE data is being transmitted.

Lower Left Window - The numbers indicate actual elevation. The decimal point before the numbers shows the activation of the level 3 position switch in the elevation motor (on above level 3). If dashes are shown in the display, the unit is either above or below the level 3 position switch, requiring it to be manually run through the switch to begin indicating actual elevation.

Lower Right Window - The numbers indicate resistance (0-100). The right most decimal point indicates the pulses from the speed sensor.

Key Functions

While in *Test Mode* press the following keys for desired information:

Hill Interval key - Lights all of the LEDs for a short period of time.

Weight Loss key - Lights only the columns.

Strength key - Lights only the rows.

Incline ↑ - Run elevation motor up.

Incline ↓ - Run elevation motor down.

Resistance + (plus) - Run resistance up.

Resistance - (minus) - Run resistance down.

Distance - Press *once* for odometer information (DST) to appear in the speed window.

Press *again* for hour meter information (HRS) to appear in the speed window.

Press *three* times for number of starts information (USES) to appear in the speed window.

Press *four* times for number of positions the elevation (ELV) has ever moved. Example: if a user runs the elevation from 2 to 3, 1 position is added to this number.

Strides Per Minute - Displays and cycles through error log. Up to 10 errors can be stored.

Scan - Clears error log when pressed twice while in error log mode.

Mets - Displays the torque in ft-lbs, (relative to LOAD).

Calories - Displays brake pulse width (PWM) value (the value of brake load in A/D counts). The number range is relative to brake current and goes from 0-200.

Enter - Required to save setup values.

Error Codes

Error codes notify you of a problem condition and are displayed on the center of the console. These codes can also help to indicate the part of the unit most likely to be causing the problem. Errors that present a hazard to the user provide a measure of safety by causing a one second beep, stopping the unit and locking out operation of the unit.

A log of errors can be viewed and cleared. Up to 10 errors can be stored.

To enter *Test Mode*: Press and hold down any key on the display while turning the power switch to the on (I) position.

To view the Error Log: Press the **Strides Per Minute** key to display and cycle through error log; Press again to cycle to the next stored error.

To clear the Error Log: Press the **Scan** key twice.

To exit *Test Mode*: Press the **Stop** key.

NOTE: A processor upset can cause a bAd#. See F then G.

| Error | Description |
|-------|---|
| bAd0 | Bad check sum. See F then E. |
| bAd2 | Internal RAM error. See F then E. |
| bAd3 | Watchdog timeout. See F then E. |
| Err3 | Speed sense lost. See A and B. |
| Err5 | No index switch sense within timed limits. This is declared when the timed elevation reaches 0% without tripping the index. See D and A. |
| Err7 | EEPROM error (memory lost, loads new defaults, enters <i>Test Mode</i>). See E. |
| ErrE | Index switch always on (or switch disconnected or wired backwards). This means that timed elevation has gone up 3 positions and the index is still sensed. See D. |

Action

| | |
|---|---|
| A | Check the lower board |
| B | Check the brake |
| C | Check the speed sensor and speed sensor disc |
| D | Check the elevation motor |
| E | Replace the display board if problem persists |
| F | Turn the power switch to the off (O) position and back on (I) |

Speed Sensor Adjustment

Tools Required

- Phillips head screwdriver

! WARNING: Disconnect the power cord before beginning this procedure. Keep wet items away from inside parts of the unit. Electrical shock could occur even if the unit is unplugged.

- 1. Disconnect the external power source.**
 - A. Turn the main power switch above the power inlet to the off (O) position.
 - B. Unplug the power cord from the power outlet.
- 2. Remove the access cover.**
 - A. Using a Phillips head screwdriver, remove the four screws securing the access cover. See Figure 2.
 - B. Remove the access cover.
- 3. Visually inspect the target disk on the lower pulley.**
 - A. Turn the lower pulley slowly and look for dirt, scratches or other damage on the target disk. See Figure 3. **NOTE:** If the target disk or speed sensor is dusty use a soft dry cloth to wipe off the dust. A dirty, scratched or damaged disk may cause Error 3 to occur.
- 4. Measure the speed sensor gap.**
 - A. Measure the gap between the speed sensor and the lower pulley. It should measure $\frac{3}{16}$ " (.48 cm) and should be parallel to the lower pulley. See Figure 3.

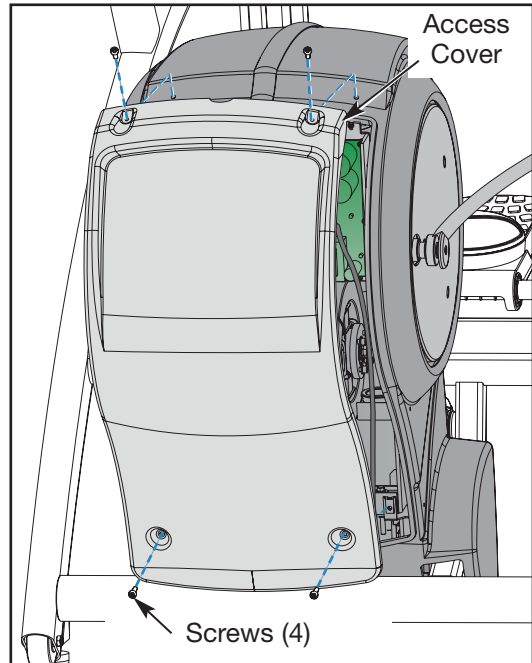

Figure 2

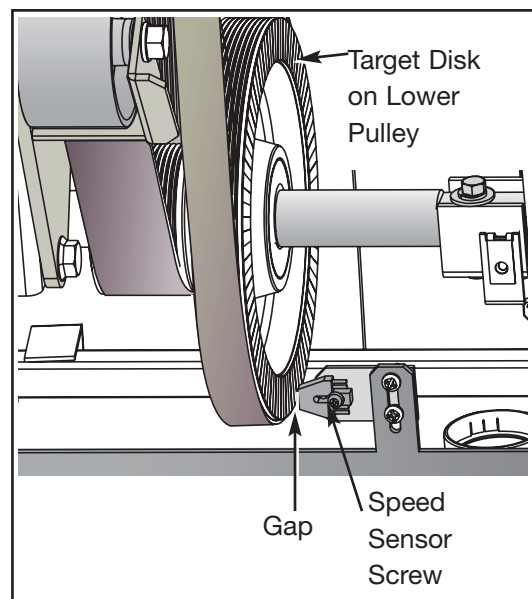

Figure 3

5. Adjust the speed sensor gap (if needed).

- A. Using a Phillips head screwdriver, loosen the screw securing the speed sensor in place. See Figure 3. **NOTE:** *Gently bend the side cover to get at the speed sensor screw.*
- B. Adjust the gap between the speed sensor and the lower pulley to 3/16" (.48 cm) and tighten the screw. See Figure 3.

6. Test for speed errors.

- A. Connect the power cord to a power outlet.
- B. Enter *Test Mode*.

! WARNING: Flywheel may be hot. Wait until it cools before servicing.

! CAUTION: Do not pinch your fingers between the belt and pulley during this procedure.

- C. Slowly move the flywheel with your hand and check the speed LED on the lower board. It should blink as the target disk passes the sensor.
- D. Mount the unit and begin striding at a steady pace.
- E. While striding, take note of the speed that is displayed in the strides-per-minute display. This number should increase as you stride faster. If the number fluctuates greatly then your speed sensor gap may need to be readjusted or replaced.
- F. Press **Stop** and turn the power switch to the off (O) position.

7. Attach the access cover.

- A. While being sure not to pinch any cables, hold the access cover in place. See Figure 2.
- B. Using a Phillips head screwdriver, tighten the four screws securing the access cover.

Drive Belts

NOTE: This procedure will cover the primary and secondary drive belts.

Tools Required

- Phillips head screwdriver
- 3/16" Allen wrench
- 2 Cloths
- 3/8" Nutdriver or socket wrench
- 7/16" Socket wrench
- 1/2" Socket wrench (only if belt tension needs to be reset)
- 1/2" Open end wrench (only if belt tension needs to be reset)
- 3/8" Square-hole torque wrench (only if belt tension needs to be reset)

! WARNING: Disconnect the power cord before beginning this procedure. Keep wet items away from inside parts of the unit. Electrical shock could occur even if the unit is unplugged.

1. Elevate the unit and disconnect the power source.

- A. Plug the power cord into the power outlet.
- B. Enter *Test Mode*.
- C. Elevate the unit to a minimum of level 7 incline.
- D. While the unit is elevated, turn the main power switch to the off (O) position and unplug the power cord from the power outlet.

2. Remove the access cover.

- A. Using a Phillips head screwdriver, remove the four screws securing the access cover. See Figure 2.
- B. Remove the access cover.

! WARNING: Flywheel may be hot. Wait until it cools before servicing.

3. Detach the connecting rods.

- A. Using a 3/16" Allen wrench, remove the Cap, SHCS and spacer securing the linkage rod. See Figure 4.
NOTE: Detach only the ends where the rods connect to the crank.
- B. Lay the linkage rod down on the frame.
NOTE: Place a cloth in between the linkage rod and the frame to prevent scratches.

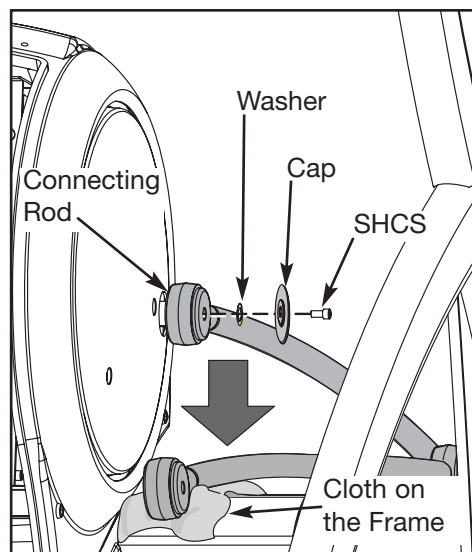

Figure 4

4. Remove the side covers.

- A. Remove the six screws and six washers securing each side cover in place. See Figure 5.
- B. Remove both side covers. **NOTE:** The gasket will come off with one of the side covers. See Figure 5.

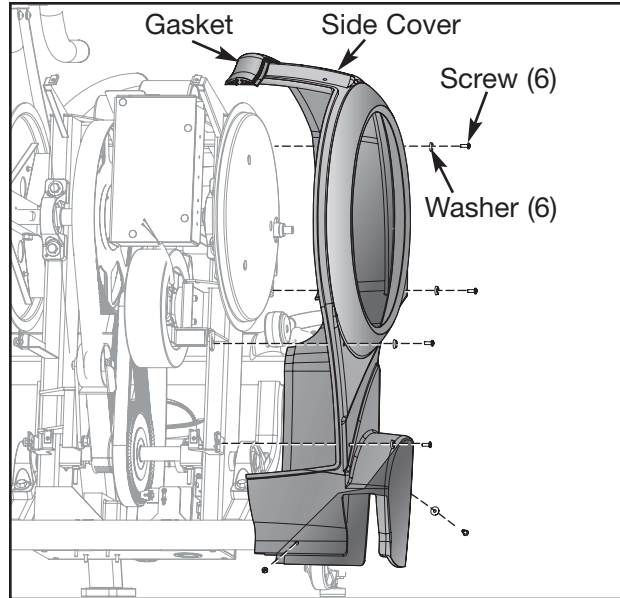

Figure 5

5. Remove the crank covers.

- A. Using a Phillips head screwdriver, remove the three screws securing each crank cover in place. See Figure 6.
- B. Remove both crank covers.

! WARNING: Failure to release the drive belt tension may cause personal injury and may damage the unit.

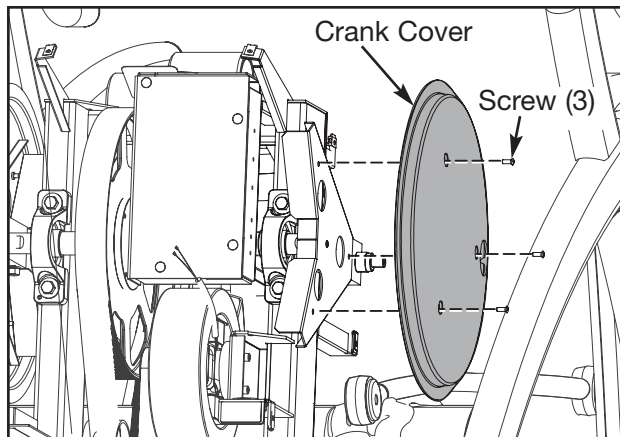

Figure 6

6. Remove the lower pivot assembly.

- A. Using a 7/16" socket wrench, remove the two screws, two lock washers and two flat washers from the lower pivot shaft. See Figure 7. **NOTE:** The tension is now released. The primary belt can be replaced without loosening the idler pulley.

NOTE: If you are not replacing the secondary belt, leave the lower pivot assembly loose in its place, skip steps 6B-8E and continue with step 9.

- B. Remove the lower pivot assembly out of the secondary belt and from the frame. See Figure 8.

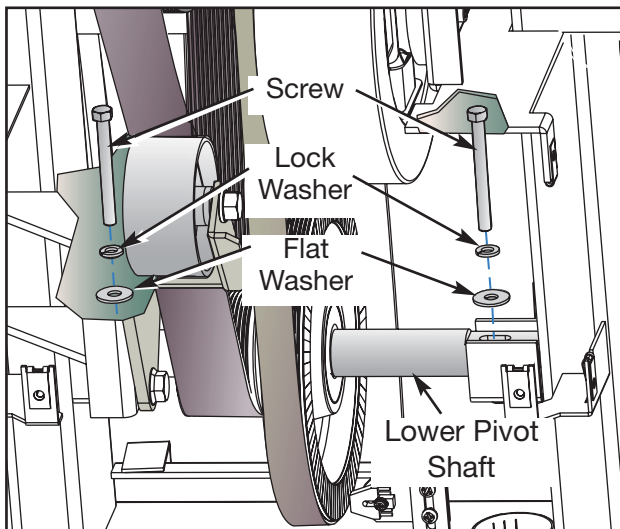

Figure 7

7. Remove the secondary belt (if applicable).

- A. Slide the secondary drive belt off the unit and discard it.

NOTE: If you are not replacing the primary belt skip to step 14.

! WARNING: Do not touch components on the lower board. A charge can remain after unplugging the power cord and turning off the unit.

8. Remove the lower board assembly (if applicable).

A. Pull out on the lower board shield. See Figure 9.
NOTE: It will snap out.

B. Disconnect the elevation motor cable from the lower board. See Figure 10.

C. Using a 3/8" nutdriver, remove the nut, washer and ground wire from the stud above the lower board. See Figure 10.

D. Using a Phillips head screwdriver, remove the top two screws from the lower board assembly and loosen the bottom two screws. See Figure 11.

E. Slide the lower board assembly to the left and off the two screws, then gently let it suspend by the cables.

9. Remove the crank shaft assembly (if applicable).

A. Using a 9/16" socket wrench and a 9/16" open end wrench, remove the two bolts, four flat washers and two nuts from each of the top pillow blocks. See Figure 12.

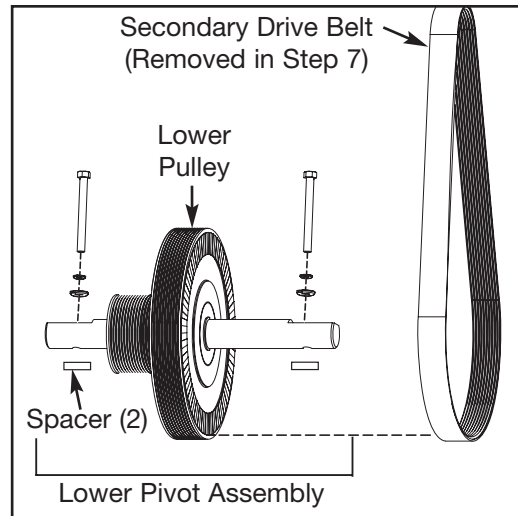

Figure 8

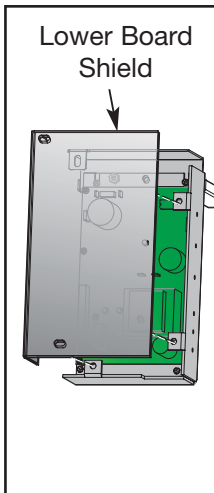

Figure 9

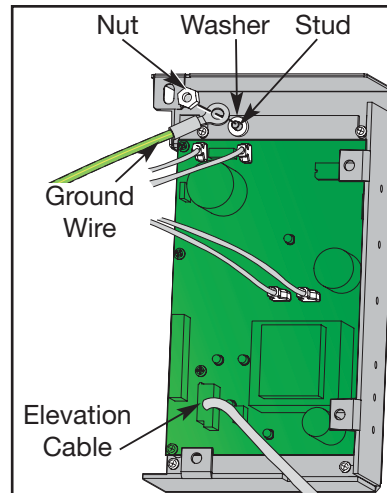

Figure 10

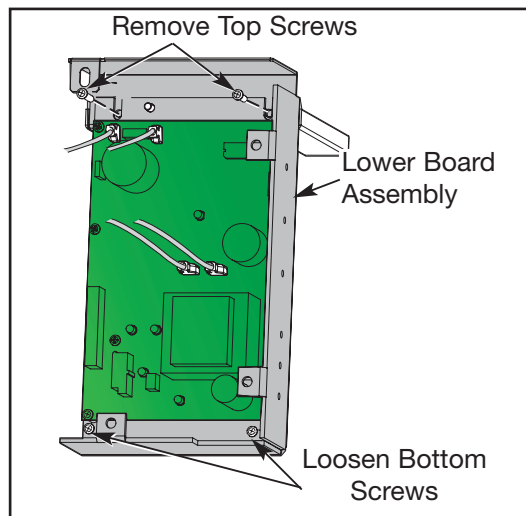

Figure 11

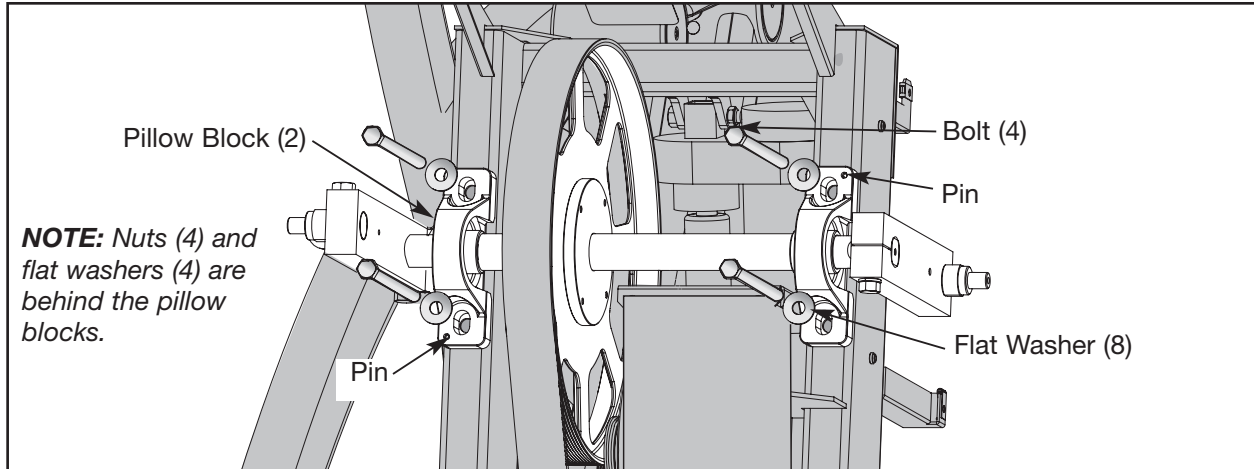

Figure 12

- B. Remove the crank shaft assembly along with the primary belt, pillow blocks and crank arms out of the unit. **NOTE:** You may need to wiggle the assembly out. There is a pin in each pillow block. Be sure not to lose them. See Figure 13.

10. Remove the primary belt (if applicable).

- A. Slide the primary drive belt off the upper pulley and discard it. See Figure 13.

11. Attach the primary belt (if applicable).

- A. Slide the new primary drive belt on the upper pulley. See Figure 13.
- B. Confirm that the primary drive belt is straight and centered on the upper pulley.

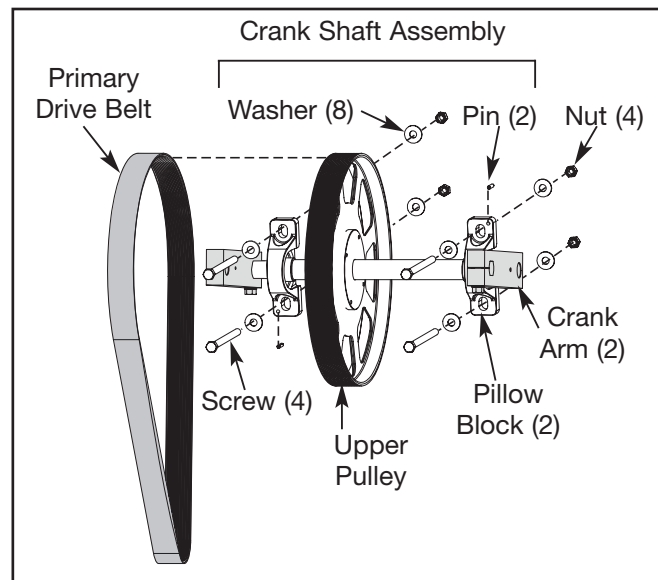

Figure 13

12. Attach the crank shaft assembly (if applicable).

- A. Confirm that a pin (removed in step 9B) protrudes about 1/4" out of the back of each pillow block. **NOTE:** The pins will slide into the frame in the next step. See Figures 12 and 13.
- B. Lift the assembly and slide the pins into the holes on the frame. **NOTE:** The pins should be flush with the front of the pillow blocks. You may need to tap them in.
- C. Using a 9/16" socket wrench and a 9/16" open end wrench, secure the two bolts, four flat washers and two nuts (removed in step 9A) to each pillow block. See Figure 12.

! CAUTION: Do not pinch your fingers between the belt and pulley during this procedure.

13. Attach the lower board assembly.

- A. Slide the lower board assembly over the two bottom screws and to the right.
- B. Using a Phillips head screwdriver, attach the top two screws and tighten the two bottom screws securing the lower board assembly in place.
- C. Place the washer on the stud then follow it with the ground wire terminal. Use a 3/8" nutdriver to secure the nut over the terminal. See Figure 10.
- D. Connect the elevation motor cable into the lower board.
- E. Place the shield into position and push in (the shield will snap in). See Figure 9.

14. Position the secondary drive belt.

- A. Slide the new secondary drive belt into place on the frame.

15. Secure the lower pivot assembly.

- A. Slide the lower pivot assembly through both drive belts and into place on the frame.
- B. Confirm that the secondary drive belt is straight and centered on the lower pulley. See Figure 12.
- C. Confirm that the two spacers are still in place under the lower pivot shaft.
- D. Using a 7/16" socket wrench, tighten the two screws, two lock washers and two flat washers securing the lower pivot assembly in place.

16. Check the tension of the primary drive belt.

- A. Press on the primary belt with your hand. You should not feel any "give" in the primary belt. If the belt "gives", follow step 17 through 18. Otherwise, skip to step 19. ***NOTE: The secondary belt is self-tensioning.***

17. Release the tension of the primary drive belt.

- A. Using a 1/2" socket wrench, loosen the bottom screw on the idler pulley. See Figure 14.
- B. Using a 1/2" socket wrench, loosen the top screw on the idler pulley See Figure 14.

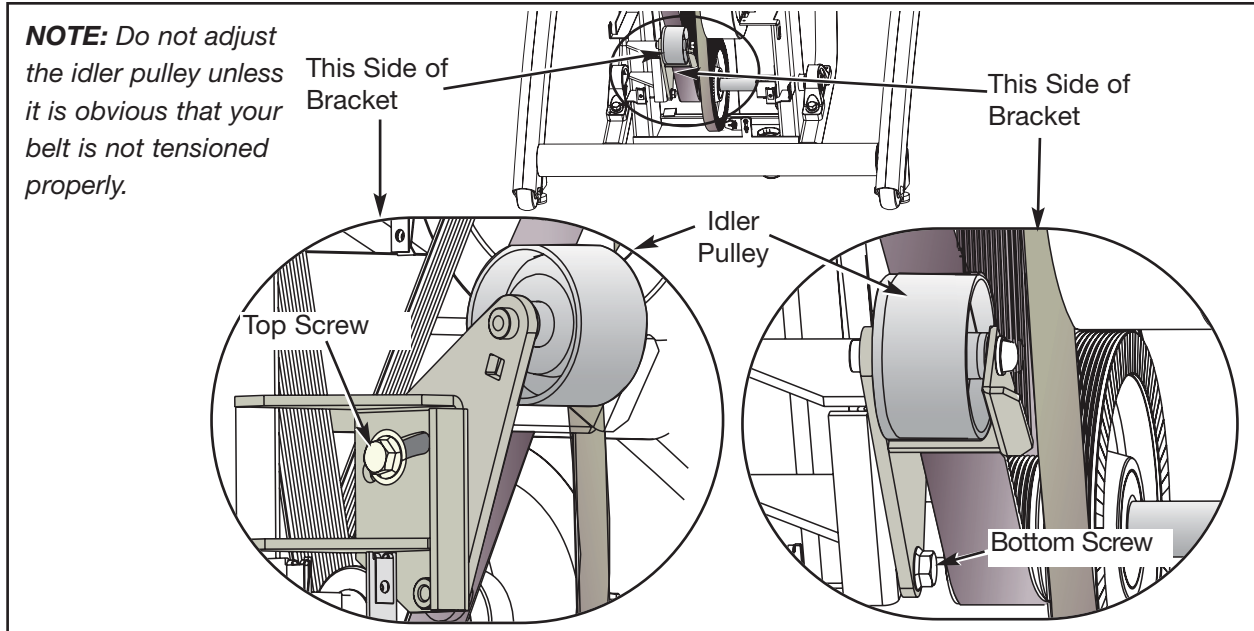

Figure 14

18. Torque the primary belt (if applicable).

- A. Using a 3/8" square-hole torque wrench, pull up until the idler wheel rocks against the brake and is torqued to 75 ft-lbs. **NOTE:** Continue holding the torque wrench at 75 ft-lbs during the next step.
- B. While holding the torque wrench at 75 ft-lbs, use a 1/2" socket wrench to tighten the top screw on the idler pulley. See Figure 14.
- C. Using a 1/2" socket wrench, tighten the bottom screw on the idler pulley. See Figure 14.

19. Attach the crank covers.

- A. Place each crank cover in position.
- B. Using a Phillips head screwdriver, attach the three screws securing each crank cover in place. See Figure 6.

20. Attach the side covers.

- A. Place each side cover in position in the rubber gasket.
- B. Using a Phillips head screwdriver, tighten the six screws and six washers securing each side cover. See Figure 5.

21. Secure the connecting rods.

- A. Using a 3/16" Allen wrench, attach the screw securing each connecting rod to each crank. See Figure 4.

22. Attach the access cover.

- A. While being sure not to pinch any cables, hold the access cover in place. See Figure 2.

- B. Using a Phillips head screwdriver, tighten the four screws securing the access cover. See Figure 2.

Eddy Current Brake

Tools Required

- Phillips head screwdriver
- 3/16" Allen wrench
- 7/16" Socket wrench
- Work Gloves

! WARNING: Disconnect the power cord before beginning this procedure. Keep wet items away from inside parts of the unit. Electrical shock could occur even if the unit is unplugged.

1. Elevate the unit and disconnect the power source.

- A. Plug the power cord into the power outlet.
- B. Enter *Test Mode*.
- C. Elevate the unit to a minimum of level 7 incline.
- D. While the unit is elevated, turn the main power switch to the off (O) position and unplug the power cord from the power outlet.

2. Remove the access cover.

- A. Using a Phillips head screwdriver, remove the four screws securing the access cover. See Figure 2.
- B. Remove the access cover.

! WARNING: Flywheel may be hot. Wait until it cools before servicing.

3. Detach the connecting rods.

- A. Using a 3/16" Allen wrench, remove the screw securing each connecting rod to each crank. See Figure 4.
- B. Place a cloth on the frame where the connecting rod will rest.
- C. Rest the rod on the cloth to prevent scratches. See Figure 4.

4. Loosen the left side cover

- A. Using a Phillips head screwdriver, remove the six screws and six washers securing each side cover in place. See Figure 5.
- B. Remove both side covers. ***NOTE: The gasket will come off with one of the side covers. See Figure 5.***

5. Remove the left crank cover.

- A. Using a Phillips head screwdriver, remove the three screws securing the left crank cover in place. See Figure 6.
- B. Remove the left crank cover.

! WARNING: Failure to release the drive belt tension may cause personal injury and may damage the unit.

6. Release the drive belt tension.

- A. Using a 7/16" socket wrench, loosen the two screws on the lower pivot shaft until the screws are raised 1/2" (1.25 cm) above the screws on the lower pivot shaft. See Figure 15. **NOTE: The drive belt tension is now released.**

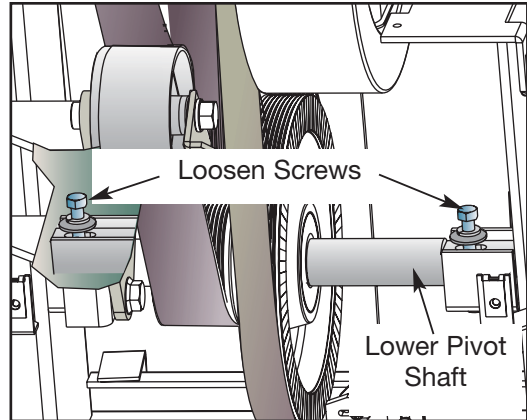

Figure 15

! WARNING: Do not touch components on the lower board. A charge can remain after unplugging the power cord and turning off the unit.

7. Disconnect the brake cables.

- A. Pull out on the lower board shield. See Figure 9. **NOTE: It will snap out.**
- B. Locate the two brake cables on the lower board that are labeled J1 and J2.
- C. Disconnect the two brake cables from the lower board.

! CAUTION: Pulley on eddy current brake is sharp. Wear work gloves to protect your hands.

8. Remove the eddy current brake.

- A. Wear work gloves whenever handling the eddy current brake. The pulley is sharp. See Figure 16.

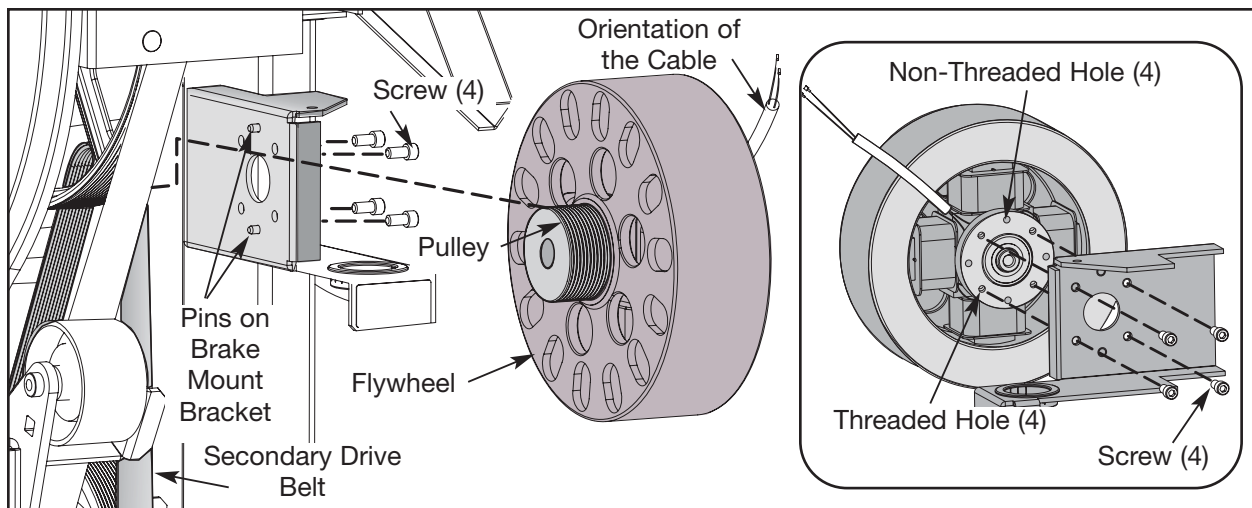

Figure 16

- B. When the flywheel is cool, remove the secondary belt from the eddy current brake.
- C. Using a 3/16" Allen wrench, first remove the two bottom screws securing the eddy current brake in place. See Figure 16.
- D. Support the brake with your hand while removing the two top screws so that it does not fall.
- E. Remove the eddy current brake from the unit. **NOTE:** *Cybex may want the old parts for evaluation. Call Cybex Customer Service to get an RMA number.*

9. Attach the new eddy current brake.

- A. Locate the holes on the eddy current brake. Notice that there are four threaded holes and four non-threaded holes. See Figure 16.
- B. Locate the two pins on the brake mount bracket. See Figure 16.
- C. Orient the brake with the cable away from the unit. See Figure 16.
- D. Slide the brake pulley into the secondary drive belt.
- E. Place the two pins in any of the non-threaded holes on the bracket. **NOTE:** *Do not place the pins in threaded holes.*
- F. Confirm that the brake is flat against the bracket and that the drive belt is straight on the pulley. **NOTE:** *Continue to support the brake during the next step.*
- G. Using a 3/16" Allen wrench, first tighten the two top screws securing the eddy current brake. See Figure 16.
- H. Tighten the two bottom screws securing the eddy current brake.

10. Connect the brake cables.

- A. Locate the J1 and J2 fast-ons on the lower board.
- B. Connect the brake cables to the lower board at J1 and J2. **NOTE:** *It does not matter which brake cable connects to J1 and J2.*
- C. Place the lower board shield in position and snap it in.

11. Tension the drive belt.

- A. Confirm that the secondary drive belt is straight and centered on the lower pulley. See Figure 12.
- B. Confirm that the two spacers are still in place under the lower pivot shaft.
- C. Using a 7/16" socket wrench, tighten the two screws on the lower pivot shaft.

! CAUTION: Do not pinch your fingers between the belt and pulley during this procedure.

D. Use your hand to slowly turn the flywheel and ensure that the belt is on straight.

12. Attach the left crank cover.

A. Place the crank cover in position.

B. Using a Phillips head screwdriver, attach the three screws removed in step 5A. See Figure 6.

13. Secure the left side cover.

A. Using a Phillips head screwdriver, attach the six screws and six washers removed in step 4A.

14. Attach the left connecting rod.

A. Place the left connecting rod in position.

B. Using a 3/16" Allen wrench, attach the screw removed in step 3A. See Figure 4.

15. Attach the access cover.

A. While being sure not to pinch any cables, place the access cover in position.

B. Using a Phillips head screwdriver, attach the four screws removed in step 2A. See Figure 2.

16. Test the unit for proper operation.

A. Connect the power cord into the power outlet.

B. Turn the main power switch above the power inlet to the on (I) position.

C. Operate the unit to verify proper operation.

Elevation Motor

Tools Required

- Phillips head screwdriver
- 3/16" Allen wrench
- 7/16" Socket wrench
- 3/8" Nutdriver or socket wrench
- 9/16" Open end wrench
- 9/16" Socket wrench

! WARNING: Disconnect the power cord before beginning this procedure. Keep wet items away from inside parts of the unit. Electrical shock could occur even if the unit is unplugged.

1. Elevate the unit and disconnect the power source.

- A. Plug the power cord into the power outlet.
- B. Enter *Test Mode*.
- C. Elevate the unit to a minimum of level 7 incline.
- D. While the unit is elevated, turn the main power switch to the off (O) position and unplug the power cord from the power outlet.

2. Remove the access cover.

- A. Using a Phillips head screwdriver, remove the four screws securing the access cover. See Figure 2.
- B. Remove the access cover.

! WARNING: Flywheel may be hot. Wait until it cools before servicing.

3. Detach the connecting rods.

- A. Using a 3/16" Allen wrench, remove the screw securing each connecting rod to each crank. See Figure 4. **NOTE:** *Detach only the ends where the rods connect to the crank.*
- B. Place a cloth on the frame where each connecting rod will rest.
- C. Rest each rod on a cloth to prevent scratches. See Figure 4.

4. Remove the side covers.

- A. Using a Phillips head screwdriver, remove the six screws and six washers securing each side cover in place. See Figure 5.
- B. Remove both side covers. **NOTE:** *The gasket will come off with one of the side covers. See Figure 5.*

5. Remove the center cover.

- A. Using a Phillips head screwdriver, remove the two screws securing the center cover in place.
- B. Remove the center cover.

! WARNING: Do not touch components on the lower board. A charge can remain after unplugging the power cord and turning off the unit.

6. Disconnect the elevation cable.

- A. Pull out on the lower board shield. **NOTE:** *It will snap out.*
- B. Disconnect the elevation cable from the lower board and slide it out of its slot on the frame.

7. Remove the elevation motor.

- A. Place your body next to the front end assembly to prevent it from pivoting and falling to the floor during the next step.
- B. Using a 9/16" open end wrench and a 9/16" socket wrench, remove the top bolt and nut securing the elevation motor in place. See Figure 17. **NOTE:** Do not lose the spacer between the bolt and nut.
- C. Pivot the front end assembly back and lean it against the frame (not the floor).
- D. Using a 9/16" open end wrench and a 9/16" socket wrench, remove the bottom bolt and nut securing the elevation motor in place. **NOTE:** Do not lose the spacer between the bolt and nut.
- E. Remove the elevation motor.
NOTE: Cybex may want the old parts for evaluation. Call Cybex Customer Service to get an RMA number.

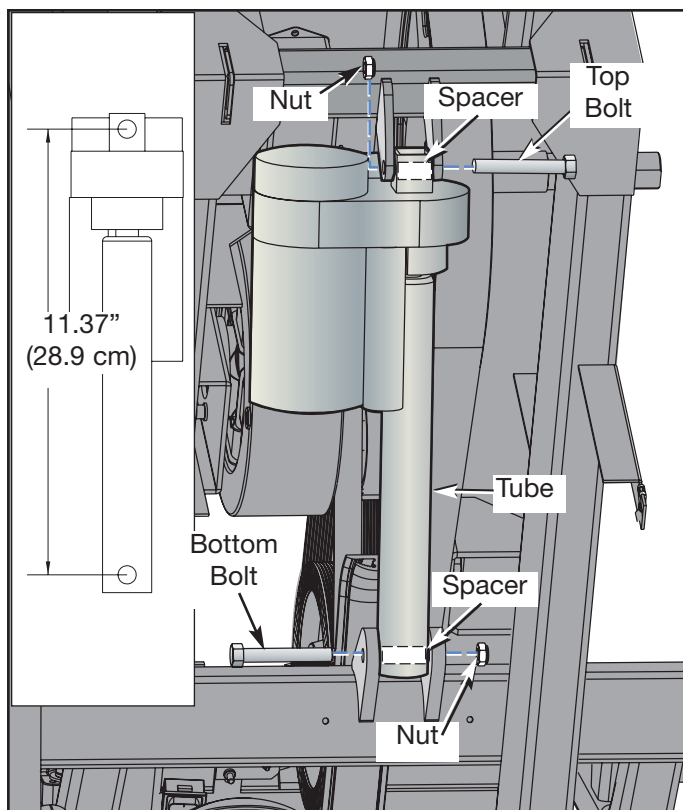

Figure 17

8. Calibrate the elevation motor.

- A. Connect the elevation motor to the lower board and temporarily connect the power. **NOTE:** The switch should automatically adjust to the level 3 position (starting level) before adjusting the tube nut.
- B. Turn the tube with your fingers until it measures 11.37" (28.9 cm) from the center of the top hole to the center of the bottom hole. See Figure 17.
- C. Turn the main power switch above the power inlet to the off (O) position and disconnect the power cord.
- D. Disconnect the elevation motor cable from the lower board and set the motor aside until step 10A.

9. Attach the elevation motor.

- A. Confirm that the two spacers (from step 7B and 7D) are in place.
- B. Pivot the front end assembly back into the position it was before step 7C.
- C. Place the new elevation motor in position and slide both bolts into the slots before tightening. See Figure 17. **NOTE:** The top bolt goes from the left to the right, but the bottom bolt can go either way.

D. Using a 9/16" open end wrench and a 9/16" socket wrench, tighten a nut on each bolt.

10. Connect the elevation cable.

A. Connect the elevation cable to the lower board and place it in the slot mentioned in step 6B.

B. Place the lower board shield in position and snap it in.

11. Secure the center cover.

A. Place the center cover in position.

B. Using a Phillips head screwdriver, attach the two screws removed in step 5A.

12. Secure the side covers.

A. Place the two side covers and the gasket in position.

B. Using a Phillips head screwdriver, attach each side cover with the six screws and six washers removed in step 4A. **NOTE:** You will have to elevate the unit to level 7 to attach the bottom two screws as discussed in step 1.

13. Attach the connecting rods.

A. Place each connecting rod in position.

B. Using a 3/16" Allen wrench, attach each connecting rod with a screw removed in step 3A. See Figure 4.

14. Attach the access cover.

A. While being sure not to pinch any cables, place the access cover in position.

B. Using a Phillips head screwdriver, attach the four screws removed in step 2A. See Figure 2.

15. Test the unit for proper operation.

A. Connect the power cord into the power outlet.

B. Turn the main power switch above the power inlet to the on (I) position.

C. Operate the unit at all levels to verify proper operation.

Power Switch

Tools Required

- Phillips head screwdriver

1. Disconnect the external power source.

- Turn the main power switch above the power inlet to the off (O) position.
- Unplug the power cord from the power outlet and from the power inlet.

2. Remove the access cover.

- Using a Phillips head screwdriver, remove the four screws securing the access cover. See Figure 2.
- Remove the access cover.

3. Remove the power switch assembly.

- Using a Phillips head screwdriver, remove the two screws on each side of the power switch. See Figure 18.
- Reach inside the unit and pull the power switch assembly up and out of the slot.
- Make note of which fast-ons are connected to the connectors.

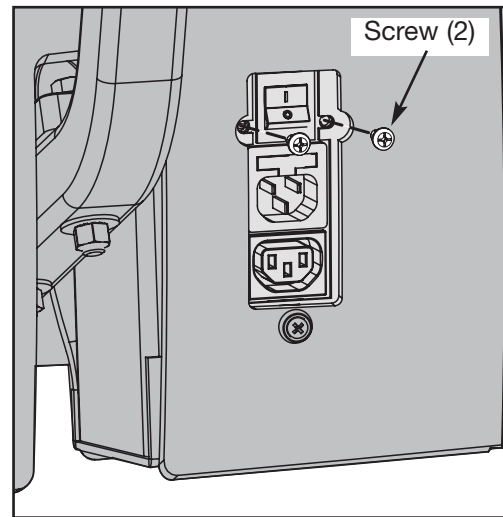

Figure 18

- Disconnect the three wires from the Filtered Power Input Module (middle one).
- Connect the three wires (removed from step 5D) to the new Filtered Power Input Module See Figure 4.
- Remove the three wires from power outlet module and remove this module from the old switch plate.
- Place the existing power outlet module into the new switch plate.
- Connect the wires as shown in Figure 4.
- With two pieces of tape, mark the top two wires to the on/off switch. **NOTE:** The purpose for marking the top two wires is so that you do not accidentally bypass the on/off switch when reconnecting the wires.
- Remove the four wires from the on/off switch and remove the switch from the old switch plate.
- Place the existing on/off switch into the new switch plate (positioned exactly as removed from the old switch plate).
- Connect the four wires as shown in Figure 4. Make sure the taped wires are connected to the same connectors from step 5I. Remove the tape from the two wires.

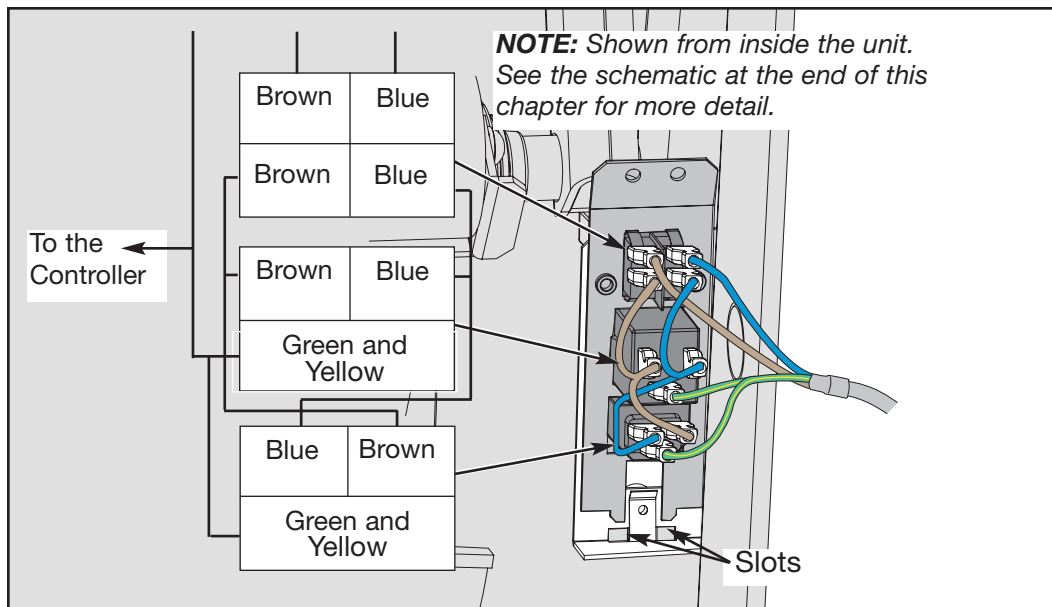

Figure 19

M. Verify the on/off switch is installed properly. See Figure 19.

4. Attach the power switch assembly.

A. Place the new power switch assembly into position. See Figure 18.

B. Using a Phillips head screwdriver, attach the two screws removed during step 3A into the power switch. See Figure 18.

5. Attach the access cover.

A. While being sure not to pinch any cables, place the access cover in position.

B. Using a Phillips head screwdriver, attach the four screws removed in step 3A.

6. Test the unit for proper operation.

A. Connect the power cord into the power inlet and the power outlet.

B. Turn the main power switch to the on (I) position.

C. Operate the unit at all levels to verify proper operation.

D. Turn main power switch off to verify it is wired properly.

Upper Pillow Blocks

Tools Required

- Phillips head screwdriver
- 3/16" Allen wrench
- 1/8" Allen wrench
- 7/16" Socket wrench
- 9/16" Socket wrench
- 9/16" Open end wrench
- 3/8" Nutdriver or socket wrench

! WARNING: Disconnect the power cord before beginning this procedure. Keep wet items away from inside parts of the unit. Electrical shock could occur even if the unit is unplugged.

1. Elevate the unit and disconnect the power source.

- A. Plug the power cord into the power outlet.
- B. Enter *Test Mode*.
- C. Elevate the unit to a minimum of level 7 incline.
- D. While the unit is elevated, turn the main power switch to the off (O) position and unplug the power cord from the power outlet.

2. Remove the access cover.

- A. Using a Phillips head screwdriver, remove the four screws securing the access cover. See Figure 2.
- B. Remove the access cover.

! WARNING: Flywheel may be hot. Wait until it cools before servicing.

3. Detach the connecting rods.

- A. Using a 3/16" Allen wrench, remove the screw securing each connecting rod to each crank. See Figure 4.
- B. Place a cloth on the frame where each connecting rod will rest.
- C. Rest each rod on a cloth to prevent scratches. See Figure 4.

4. Remove the side covers.

- A. Using a Phillips head screwdriver, remove the six screws and six washers securing each side cover in place. See Figure 5.
- B. Remove both side covers. ***NOTE: The gasket will come off with one of the side covers.*** See Figure 5.

5. Remove the crank covers.

- A. Using a Phillips head screwdriver, remove the three screws securing each crank cover in place. See Figure 6.
- B. Remove both crank covers.

! WARNING: Failure to release the drive belt tension may cause personal injury and may damage the unit.

6. Release the drive belt tension.

- A. Using a 7/16" socket wrench, loosen the two screws on the lower pivot shaft until the screws are raised 1/2" above the shaft. See Figure 15. **NOTE:** The drive belt tension is now released.

7. Remove the crank arm disk supports.

- A. Using a Phillips head screwdriver, remove the one screw securing each crank arm disk support in place. See Figure 20.

! WARNING: Do not touch components on the lower board. A charge can remain after unplugging the power cord and turning off the unit.

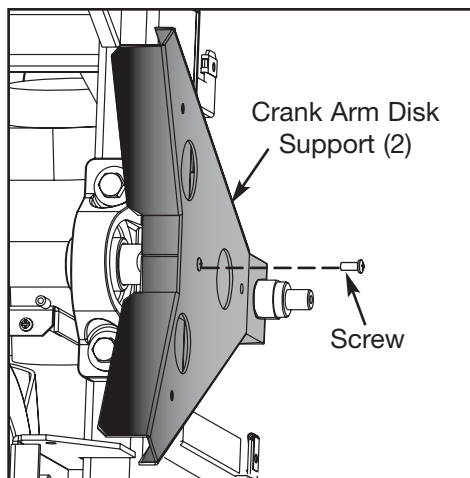

Figure 20

8. Remove the lower board assembly.

- A. Pull out on the lower board shield. **NOTE:** It will snap out.
- B. Disconnect the elevation cable from the lower board.
- C. Using a 3/8" nutdriver, remove the nut, washer and ground wire from the stud above the lower board.
- D. Using a Phillips head screwdriver, remove the top two screws from the lower board assembly and loosen the bottom two screws.
- E. Slide the lower board assembly left and off the two bottom screws then gently suspend it by the cables.

9. Remove the crank arms.

- A. Using a 7/16" socket wrench, loosen but do not remove the one screw on each crank arm. See Figure 21.
- B. Remove the crank arms.

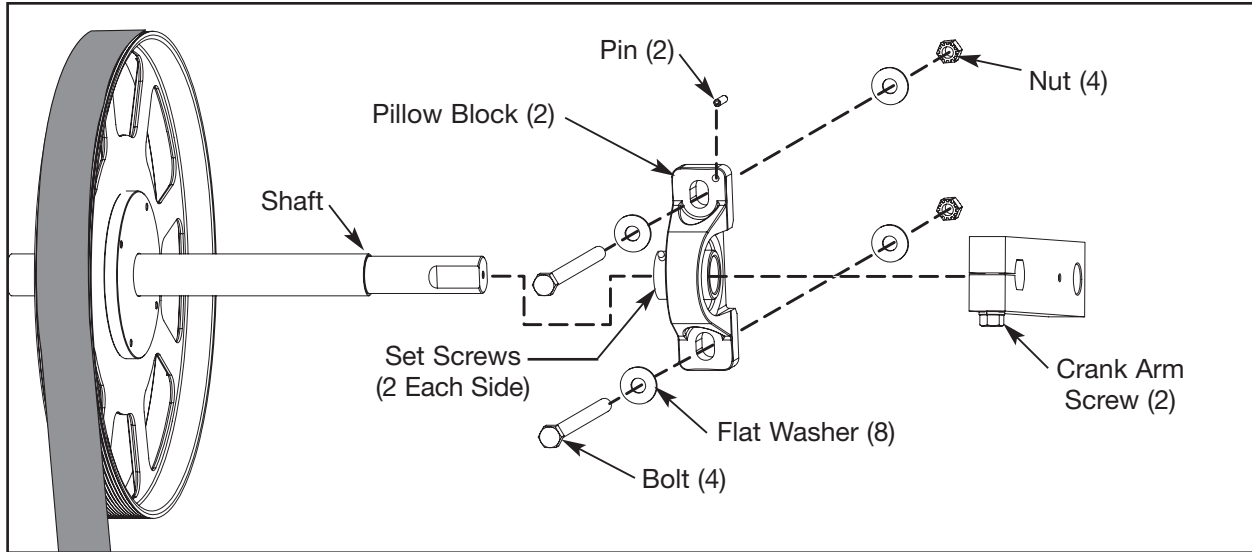

Figure 21

10. Remove the crank shaft assembly.

- A. Using a 9/16" socket wrench and a 9/16" open end wrench, remove the two bolts, four flat washers and two nuts from each of the top pillow blocks. See Figure 12.
- B. Remove the crank shaft assembly along with the primary belt and pillow blocks out of the unit. **NOTE:** There is a pin in each pillow block. See Figure 13.

11. Remove the top pillow blocks.

- A. Using a 1/8" Allen wrench, loosen but do not remove the two set screws on each pillow block. See Figure 21.
- B. Pull each pillow block off the shaft. See Figure 21.
- C. Discard the pillow blocks and pins (if applicable).

12. Attach the new top pillow blocks.

- A. Slide a pillow block on each end of the shaft. See Figure 21. **NOTE:** Orientation of pillow block sleeve and set screws must go toward the inside. Do not tighten the set screws until step 13F.

13. Attach the crank shaft assembly.

- A. Confirm that a pin protrudes about 1/4" out of the back of each pillow block and flush with the front. **NOTE:** The pins will slide into the frame in the next step.
- B. Place the assembly into the primary belt and slide the pins into the holes on the frame. **NOTE:** The pins should still be flush with the front of the pillow blocks. You may need to tap them in.
- C. Confirm that the belt is straight on the upper pulley.
- D. Using a 9/16" socket wrench and a 9/16" open end wrench, secure the two bolts, four flat washers and two nuts (removed in step 10A) to each pillow block. See Figure 12.

- E. Using a 1/8" Allen wrench, tighten the two set screws on each pillow block.

! CAUTION: Do not pinch your fingers between the belt and pulley during this procedure.

14. Secure the crank arms.

- A. Slide each crank arm in place. **NOTE:** *The face of each crank arm should be flush with the end of each shaft.*
- B. Using a 7/16" socket wrench, tighten the one screw on each crank arm.

15. Attach the lower board assembly.

- A. Place the lower board assembly over the two bottom screws and slide it to the right.
- B. Using a Phillips head screwdriver, attach the top two screws removed in step 8D and tighten the bottom two screws.
- C. Connect the elevation cable to the lower board and slide it into its slot on the frame.
- D. Place the washer (first) and the ground terminal (next) onto the stud and tighten with the nut removed during step 8C.
- E. Place the lower board shield in position and snap it in.

16. Attach the crank arm disk supports.

- A. Using a Phillips head screwdriver, attach each crank arm disk support with one screw removed during step 7A. See Figure 20.

17. Tension the drive belt.

- A. Using a 7/16" socket wrench, tighten the two screws on the lower pivot shaft. See Figure 15.

18. Attach the crank covers.

- A. Place each crank cover in position.
- B. Using a Phillips head screwdriver, attach each crank cover with three screws removed in step 5A. See Figure 6.

19. Secure the side covers.

- A. Place the two side covers and gaskets in position.
- B. Using a Phillips head screwdriver, attach each side cover with the six screws and six washers removed in step 4A.

20. Attach the connecting rods.

- A. Place each connecting rod in position.

- B. Using a 3/16" Allen wrench, attach each connecting rod with a screw removed in step 3A. See Figure 4.

21. Attach the access cover.

- A. While being sure not to pinch any cables, place the access cover in position.
- B. Using a Phillips head screwdriver, attach the four screws removed in step 2A. See Figure 2.

22. Test the unit for proper operation.

- A. Connect the power cord into the power outlet.
- B. Turn the main power switch above the power inlet to the on (I) position.
- C. Operate the unit at all levels to verify proper operation.

Lower Pillow Blocks

Tools Required

- Phillips head screwdriver
- 3/16" Allen wrench
- 1/8" Allen wrench
- 2.5" (6.3 cm) Wooden block
- 9/16" Socket wrench
- 9/16" Open end wrench

! WARNING: Disconnect the power cord before beginning this procedure. Keep wet items away from inside parts of the unit. Electrical shock could occur even if the unit is unplugged.

1. Elevate the unit and disconnect the power source.

- A. Plug the power cord into the power outlet.
- B. Enter *Test Mode*.
- C. Elevate the unit to a minimum of level 7 incline.
- D. While the unit is elevated, turn the main power switch to the off (O) position and unplug the power cord from the power outlet.

2. Remove the access cover.

- A. Using a Phillips head screwdriver, remove the four screws securing the access cover. See Figure 2.
- B. Remove the access cover.

! WARNING: Flywheel may be hot. Wait until it cools before servicing.

3. Detach the connecting rods.

- A. Using a 3/16" Allen wrench, remove the screw securing each connecting rod to each crank. See Figure 4.
- B. Place a cloth on the frame where each connecting rod will rest.
- C. Rest each rod on a cloth to prevent scratches. See Figure 4.

4. Remove the side covers.

- A. Using a Phillips head screwdriver, remove the six screws and six washers securing each side cover in place. See Figure 5.
- B. Remove both side covers. **NOTE:** The gasket will come off with one of the side covers. See Figure 5.

5. Remove the lower pillow blocks.

- A. Place a wooden block under the inner frame. See Figure 22.
- B. Using a 9/16" socket wrench and a 9/16" open end wrench, remove the two bolts, four flat washers and two nuts from each of the bottom pillow blocks. See Figure 22.

- C. Pull each pillow block and pin off the frame. See Figure 22. **NOTE:** You may need to tilt the pillow block up or pry it up off the frame. There is a pin in each pillow block.

- D. Discard the pillow blocks and pins (if applicable).

6. Attach the new lower pillow blocks.

- A. Confirm that a pin protrudes out of the back of each pillow block about 1/4" and flush with the front.
- B. Slide each pillow block on the shaft and each pin in its slot on the frame. **NOTE:** Orientation of pillow block sleeve and set screws must go toward the inside. When installed properly the pins should be flush with the front of the pillow blocks. You may need to tap them in.

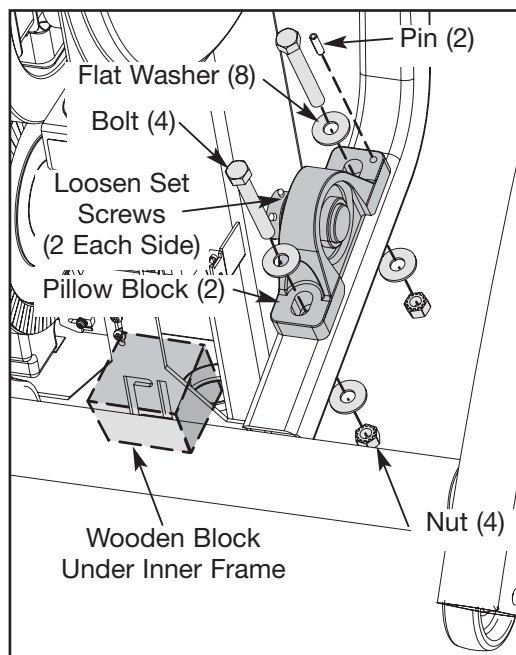

Figure 22

- C. Using a 1/8" Allen wrench, tighten the two set screws on each pillow block.
- D. Remove the wooden block from under the inner frame. See Figure 22.

7. Secure the side covers.

- A. Place the two side covers and gasket in position.
- B. Using a Phillips head screwdriver, attach each side cover with the six screws and six washers removed in step 4A.

8. Attach the connecting rods.

- A. Place each connecting rod in position.
- B. Using a 3/16" Allen wrench, attach each connecting rod with a screw removed in step 3A. See Figure 4.

9. Attach the access cover.

- A. While being sure not to pinch any cables, place the access cover in position.
- B. Using a Phillips head screwdriver, attach the four screws removed in step 2A.

Arm and Handle Link

NOTE: *The arms and handle links are removed in the same way. This procedure can be used for both.*

Tools Required

- Phillips head screwdriver
- 3/16" Allen wrench
- 7/32" Allen wrench

1. Disconnect the external power source.

- A. Turn the main power switch above the power inlet to the off (O) position.
- B. Unplug the power cord from the power outlet.

2. Disconnect the contact heart rate cable.

- A. Unplug the contact heart rate cable from the main frame. See Figure 23.

3. Remove the handle link.

- A. Using a Phillips head screwdriver or 3/16" Allen wrench, remove each screw securing the (appropriate) cap. See Figure 24.
- B. Remove the caps.
- C. Slide the handle link off the foot plate arm shaft.
- D. Slide the handle link off the arm shaft. **NOTE:** *Arm will move freely. Hold in place until step 4.*

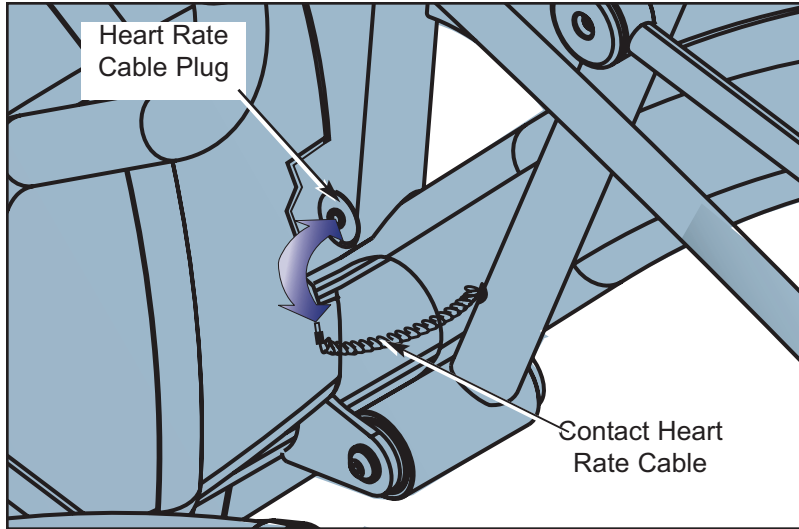

Figure 23

4. Remove arm.

- A. Using a 7/32" Allen wrench remove the two screws and two washers securing the arm to the frame.
- B. Remove arm from frame.

5. Attach the new arm.

- A. Slide the (appropriate) arm into the frame.
- B. Using a 7/32" Allen wrench secure the arm to the frame using the screws and washers removed in step 4A.
- C. Using a Phillips head screwdriver or 3/16" Allen wrench, attach handle link with the (appropriate) screw securing the cap. See Figure 24.

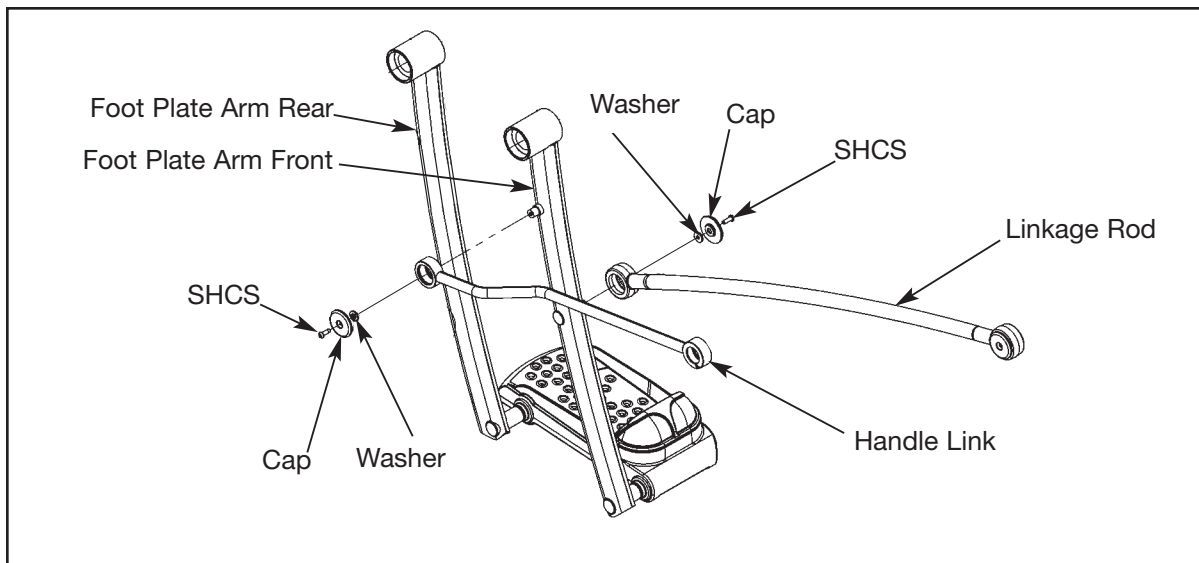

Figure 24

6. Attach the new handle link.

- A. Slide the handle link onto the arm shaft and foot plate arm shaft.
- B. Using a Phillips head screwdriver or 3/16" Allen wrench, secure handle link with the screws and (appropriate) cap removed in step 3A.

7. Connect the contact heart rate cable.

- A. Plug the contact heart rate cable into the plug in the main frame. See Figure 23.

Pedal Arm and Foot Plates

NOTE: *The pedal arms and foot plates are removed in the same way. This procedure can be used for both.*

Tools Required

- Phillips head screwdriver
- 3/16" Allen wrench
- Threadlocker

1. Disconnect the external power source.

- A. Turn the main power switch above the power inlet to the off (O) position.
- B. Unplug the power cord from the power outlet.

2. Remove the foot plate and pedal arm.

- A. Using a Phillips head screwdriver or 3/16" Allen wrench, remove each SHCS securing the (appropriate) cap. See Figure 25.
- B. Remove the cap.
- C. Slide the foot plate off the foot plate shafts (if applicable).
- D. Slide the (appropriate) arm off the shaft (or shafts).

3. Attach the new foot plate and pedal arm.

- A. Slide the (appropriate) arm on the shaft (or shafts).
- B. Slide the foot plate on the foot plate shafts (if applicable).
- C. Place a drop of threadlocker on one of the SHCS. Place another drop of threadlocker in the shaft (where the SHCS will be tightened into).
- D. Using a Phillips head screwdriver or 3/16" Allen wrench, attach cap with the (appropriate) SHCS securing the cap. See Figure 25. **NOTE:** *SHCS must be tightened to a minimum of 100 inch-pounds.*

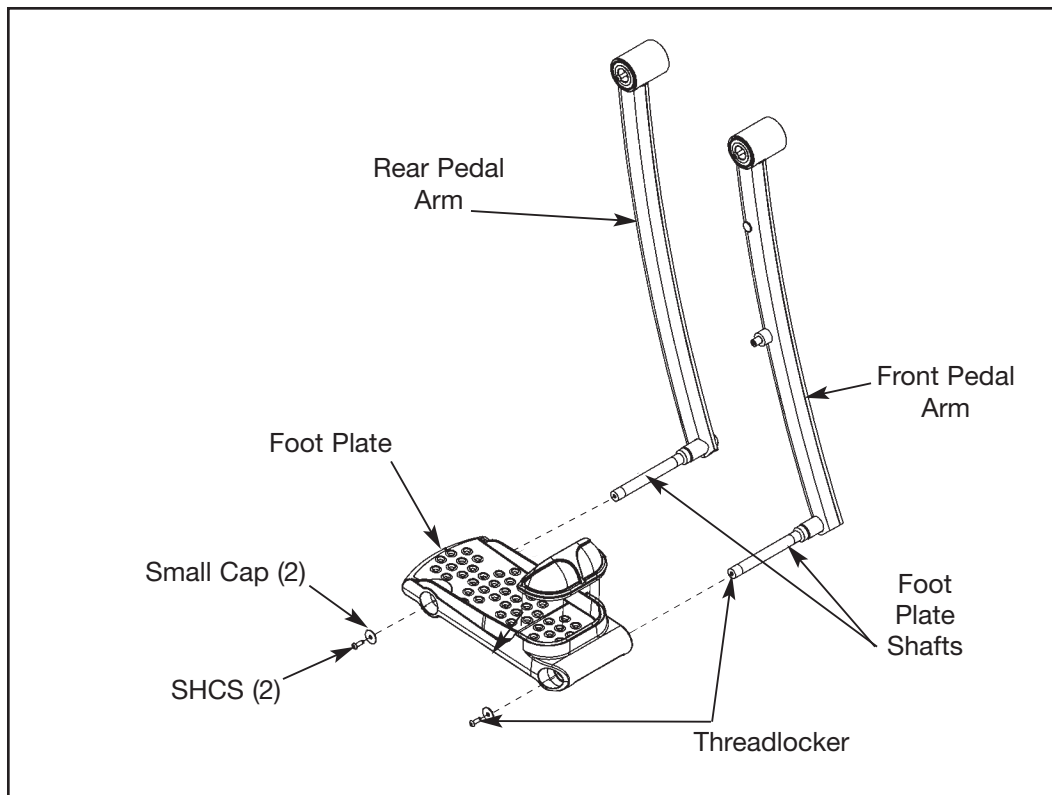

Figure 25

Lower Control Board

Tools Required

- Phillips head screwdriver
- 3/8" Nutdriver or socket wrench
- ESD (Electro Static Discharge) grounding strap

! WARNING: Disconnect the power cord before beginning this procedure. Keep wet items away from inside parts of the unit. Electrical shock could occur even if the unit is unplugged.

1. Disconnect the external power source.

- A. Turn the main power switch above the power inlet to the off (O) position.
- B. Unplug the power cord from the power outlet.

2. Remove the access cover.

- A. Using a Phillips head screwdriver, remove the four screws securing the access cover. See Figure 2.
- B. Remove the access cover.

! WARNING: Flywheel may be hot. Wait until it cools before servicing.

3. Disconnect the cables from the lower board.

- A. Pull out on the lower board shield. **NOTE:** *It will snap out.*
- B. Disconnect the cables from the lower board. This includes the elevation motor cable, display cable (P1), AC line 1 (J3 black), AC line 2 (J7 white), eddy current brake cable (J1 and J2) and speed sensor cable (J4).
- C. Using a 3/8" nutdriver, remove the nut, washer and ground wire from the stud above the lower board. See Figure 10.

! WARNING: Do not touch components on the lower board. A charge can remain after unplugging the power cord and turning off the unit.

4. Remove the lower board assembly.

- A. Using a Phillips head screwdriver, remove the top two screws from the lower board assembly and loosen the bottom two screws.
- B. Slide the lower board assembly left and off the bottom screws. **NOTE:** *Cybex may want the old parts for evaluation. Call Cybex Customer Service to get an RMA number.*

5. Attach the lower board assembly.

- A. Place the lower board assembly over the two bottom screws and slide it to the right.
- B. Using a Phillips head screwdriver, attach the top two screws removed in step 4A and tighten the bottom two screws.

6. Connect the cables to the lower board.

- A. Connect the cables to the lower board. This includes the elevation motor cable, display cable (P1), AC line 1 (J3 black), AC line 2 (J7 white), eddy current brake cable (J1 and J2) and speed sensor cable (J4).
- B. Place the washer (first) and the ground terminal (next) onto the stud and tighten with the nut removed during step 3C.
- C. Place the lower board shield in position and snap it in.

7. Test the unit for proper operation.

- A. Connect the power cord into the power outlet.
- B. Turn the main power switch above the power inlet to the on (I) position.
- C. Operate the unit at all levels to verify proper operation.

Lower Control Board Fuses

TOOLS REQUIRED

- Phillips screwdriver
- Needle nosed pliers
- Two (2) Fuses, part number EF-12417.

1. Disconnect the external power source.

- A. Turn the main power switch above the power inlet to the off (0) position.
- B. Unplug the power cord from the power outlet.

! WARNING: Disconnect the power cord before continuing this procedure. Keep wet items away from inside parts of the unit. Electrical shock could occur even if the unit is unplugged.

2. Remove the access cover.

- A. Using a Phillips screwdriver, remove the four screws and four washers securing the access cover. See Figure 2.
- B. Remove the access cover.

! WARNING: Flywheel may be hot. Wait until it cools before servicing.

! WARNING: Do not touch components on the lower board. A charge can remain after unplugging the power cord and turning off the unit.

3. Replace the fuses.

- A. Locate the lower board.
- B. Pull out on the lower board shield (it will snap out). See Figure 26.
- C. Locate the fuses in the upper left hand corner of the control board. See Figure 26.
- D. Replace the old fuses with the new fuses.
- E. Place the lower shield (removed in step 5B) into position and secure the finned fasteners (the shield with snap in).
- F. Attach the access cover removed in steps 2A and 2B. **NOTE:** Be careful not to pinch any cables.

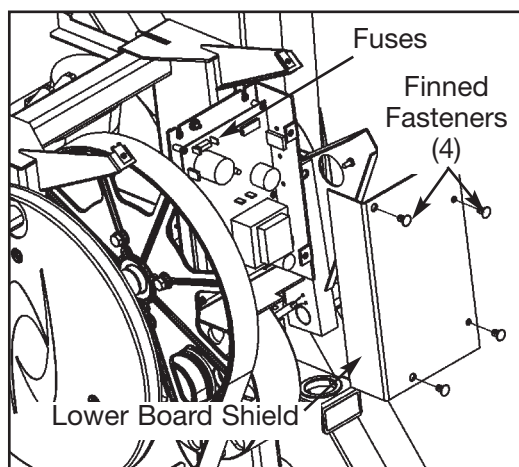

Figure 26

Upper Display Board

Tools Required

- Phillips head screwdriver
- ESD (Electro Static Discharge) grounding strap

1. Disconnect the external power source.

- A. Turn the main power switch above the power inlet to the off (O) position.
- B. Unplug the power cord from the power outlet.

NOTE: Wear an ESD strap for the rest of this procedure.

2. Remove the console front.

- A. Using a Phillips head screwdriver, remove the screw securing the access cover to the console back. See Figure 27.
- B. Using a Phillips head screwdriver, remove the four screws securing the console front to the console back.
- C. Gently pull the console front forward and disconnect these cables from the display board: the display cables; the contact heart rate cables; ground wire and the polar heartrate cable. See Figure 28.

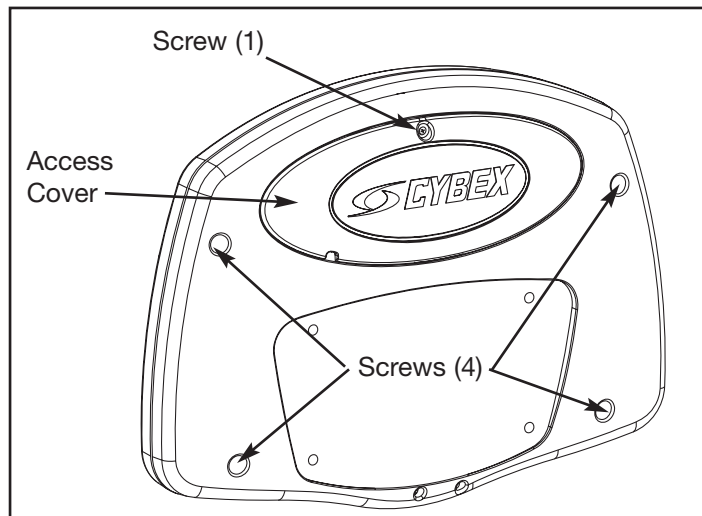

Figure 27

3. Remove the display board.

- A. Using a Philips head screwdriver, remove the five display board mounting screws.
- B. Lift and rotate the display board to the right and unplug the three overlay ribbon cables from the display board. Set the display board aside. **NOTE:** Cybex may want the old parts for evaluation. Call Cybex Customer Service to get an RMA number.

4. Attach the new display board.

- A. Plug the overlay ribbon cables into the appropriate connectors in the display board.
- B. Using a Phillips head screwdriver, securing the display board to the console with the five screws removed in step 3A.

5. Connect the cables.

- A. Connect these cables into the display board: the display cable; the two upper switch overlay connectors; the lower switch overlay connector; the contact heart rate cable; ground wire and the polar heartrate cable. See Figure 28.

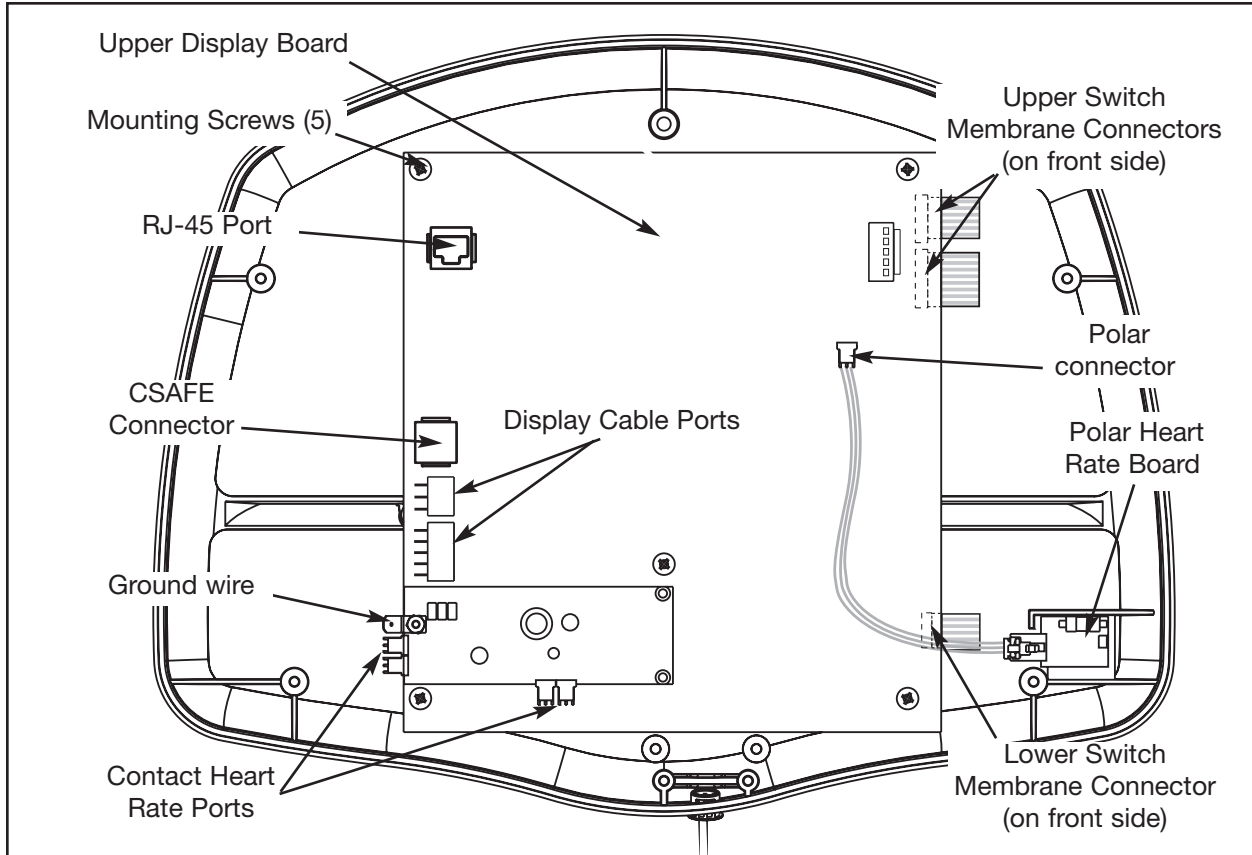

Figure 28

6. Check the connections:

- A. Check to see that all of the cables are connected firmly in their proper place.

7. Secure the console back.

- A. While being sure not to pinch any cables, use a Phillips head screwdriver to tighten four screws securing the console front to the console back.
- B. Using a Phillips head screwdriver secure the access cover to the console back with the screw removed in step 2A.

Upper Display Cable

Tools Required

- 7/32" Allen wrench
- Phillips head screwdriver
- ESD (Electro Static Discharge) grounding strap

1. Disconnect the external power source.

- A. Turn the main power switch above the power inlet to the off (O) position.
- B. Unplug the power cord from the power outlet.

NOTE: *Wear an ESD strap for the rest of this procedure.*

2. Remove the console front.

- A. Using a Phillips head screwdriver, remove the screw securing the access cover to the console back. See Figure 27.
- B. Using a Phillips head screwdriver, remove the four screws securing the console front to the console back. See Figure 27.
- C. Gently pull the console front forward and disconnect these cables from the display board: the display cable; the contact heart rate cable; ground wire and the polar heartrate cable. See Figure 28.

3. Remove the console mount.

- A. Using a 7/32" Allen wrench, remove the four screws and four lock washers securing the console mount in place. See Figure 29.
- B. Remove the console mount by lifting upward.

4. Remove the upper display cable.

- A. Disconnect the upper display cable from the lower display cable. See Figure 29.

5. Attach the new upper display cable.

- A. Locate the end of the upper display cable with the single connector. See Figure 29.
- B. Connect the upper display cable to the lower display cable. **NOTE:** *If you are changing the lower display cable disregard this step.*

7. Attach the console mount.

- A. Insert the upper display cable into the console mount and place on top of the base assembly. See Figure 29.
- B. Using a 7/32" Allen Wrench, attach the four screws and four lock washers securing the console mount in place.

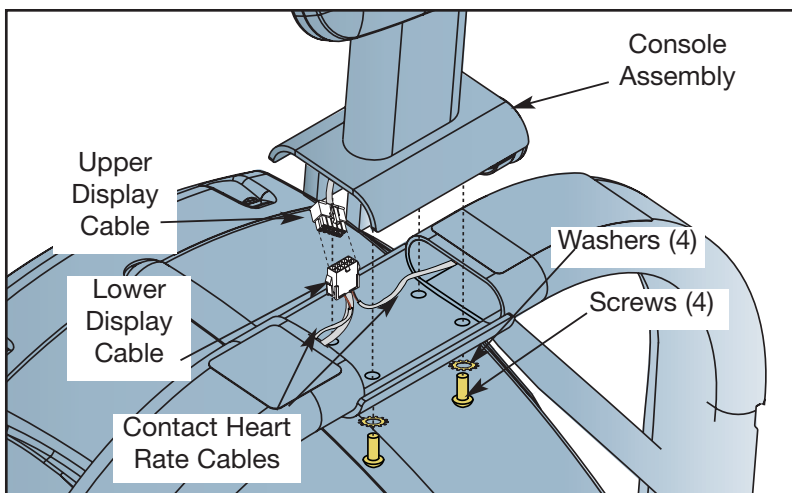

5. Connect the cables.

- A. Connect these cables into the display board: the display cable; the two upper switch membrane connectors; the lower switch membrane connector; the contact heart rate cable and the polar heartrate cable. See Figure 28.

Figure 29

6. Check the connections:

- A. Check to see that all of the cables are connected firmly in their proper place.

7. Secure the console back.

- A. While being sure not to pinch any cables, use a Phillips head screwdriver to tighten four screws securing the console front to the console back removed in step 2B.
- B. Using a Phillips head screwdriver secure the access cover to the console back with the screw removed in step 2A.

Lower Display Cable

Tools Required

- Flat head screwdriver
- Phillips head screwdriver
- 9/16" Open-end wrench or socket wrench
- 3/16" Allen wrench
- Tape
- Wire Cutters

! WARNING: Disconnect the power cord before beginning this procedure. Keep wet items away from inside parts of the unit. Electrical shock could occur even if the unit is unplugged.

1. Disconnect the external power source.

- A. Turn the main power switch above the power inlet to the off (O) position.
- B. Unplug the power cord from the power outlet.

2. Remove the access cover.

- A. Using a Phillips head screwdriver, loosen the four screws securing the access cover. See Figure 2.
- B. Remove the access cover.

3. Remove the console assembly.

- A. Using an Allen wrench, remove the four screws and four lock washers securing the console assembly in place.
- B. Carefully lift console assembly and disconnect the upper display cable from the lower display cable. See Figure 29.

4. Remove the left wheel.

- A. Place a wooden block under the unit to take the weight off the left wheel.
- B. Using a 9/16" wrench and a 3/16" Allen wrench, remove the bolt and nut securing the left wheel in place. See Figure 30.

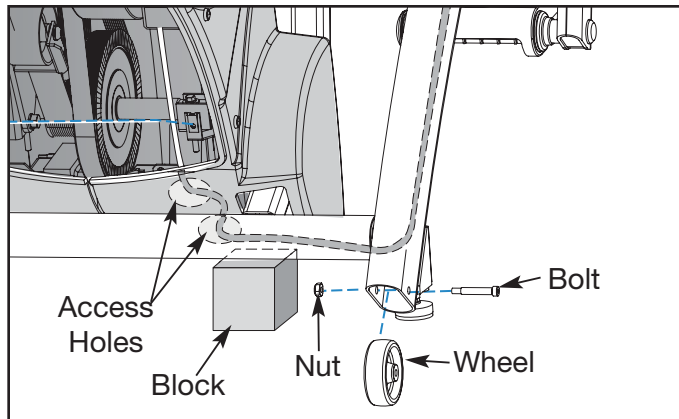

Figure 30

5. Detach the lower display cable.

! WARNING: Do not touch components on the lower board. A charge can remain after unplugging the power cord and turning off the unit.

- A. Pull out on the lower board shield.
NOTE: It will snap out.
- B. Disconnect the display cable from the lower board. See Figure 31.
- C. Remove the lower display cable from the wire holder bracket. See Figure 31.

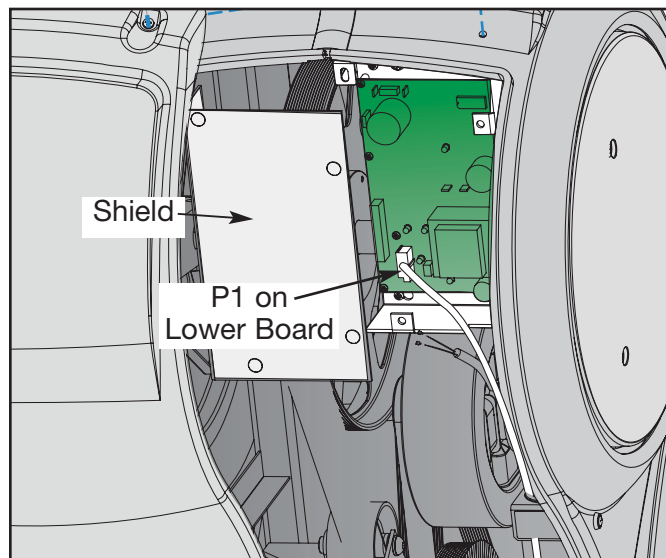

Figure 31

6. Attach the new lower display cable.

- A. Using wire cutters, cut both sets of the old contact heart rate cables from the old lower display cable (these are the small pairs of brown and black cables). See Figure 29.

NOTE: The heart rate cables have a left and a right side, they must be wired correctly.

- B.** Locate the new contact heart rate cables connected to the lower display cable. The right side cables are located in the outermost locations in the lower display cable connector. See Figure 32.

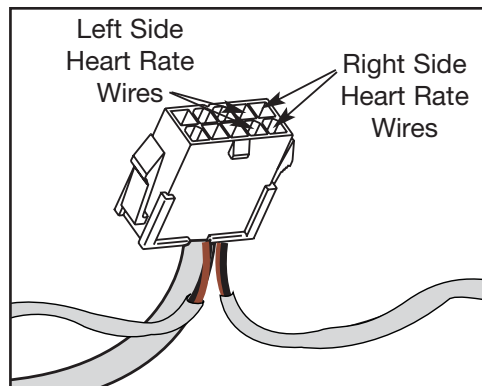

- C.** Tape the new pairs of contact heart rate wires to the old wires cut in step 6A. See Figure 33. **NOTE:** One brown wire and one black wire make a pair.

- D.** Locate the new cable's 10 pin connector end of the lower display cable.

- E.** Tape the new 10 pin connector to the old lower display cable. **NOTE:** Be sure to tape the correct ends together. See Figure 33.

Figure 32

- F.** Using a flat head screwdriver pry the contact heart rate cable plug out of the frame. See Figure 23.

- G.** Gently pull all three cables through the frame tubes. See Figure 34. **NOTE:** Stop pulling when the new cables exit the frame tubes.

- H.** Remove the tape and discard the old cable.

- I.** Confirm that the cable is routed through the access holes (see Figure 30) and through the wire holder bracket (see Figure 35).

- J.** Connect the display cable to the lower control board.

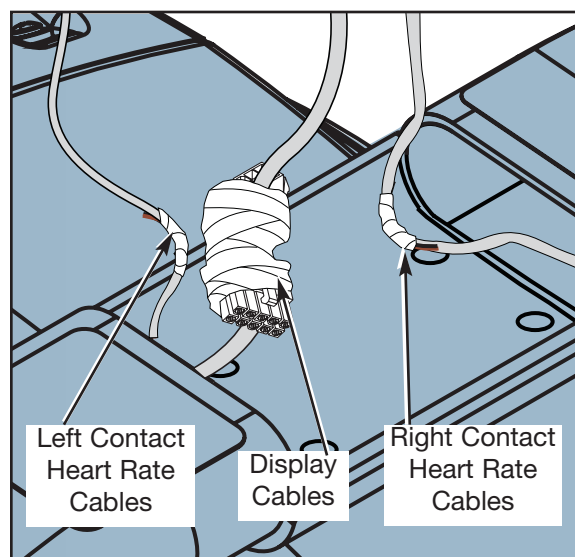

Figure 33

- K.** Connect the contact heart rate cables to the cable plugs removed in step 6F.

- L.** Plug the two contact heart rate cable sockets into the frame.

7. Attach the console.

- A.** Place the console assembly in position and connect the upper display cable to the lower display cable. See Figure 29.

- B.** Using an Allen wrench, attach the four screws and four lock washers securing the console assembly in place.

8. Secure the cable.

- A.** Check to see that all of the connectors are connected firmly in their proper place.

- B.** Place the lower board shield in position and snap it in.

9. Attach the access cover.

- A.** While being sure not to pinch any cables, place the access cover in position.

- B.** Using a Phillips head screwdriver, attach the four screws removed in step 2A.

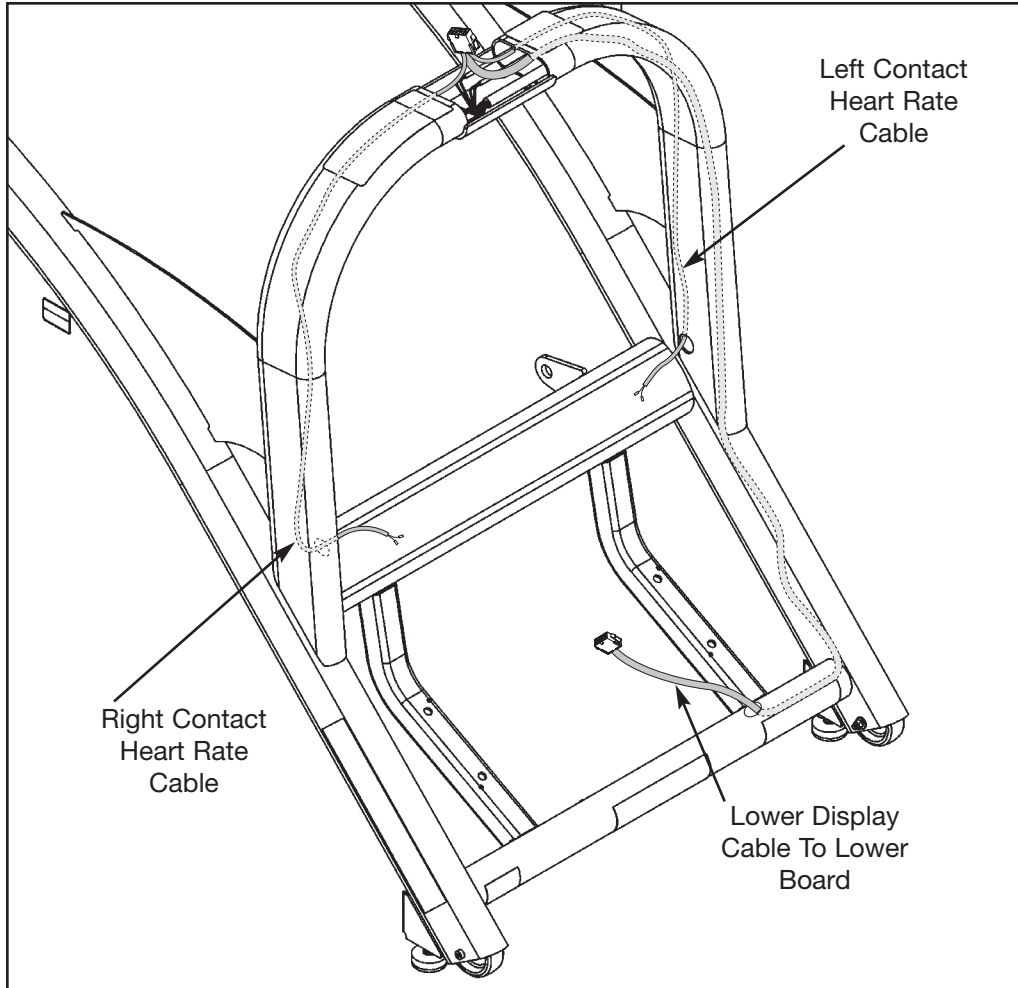

Figure 34 **NOTE:** Frame only shown for cable routing.

10. Attach the left wheel.

- A. Using a 9/16" wrench and a 3/16" Allen wrench, attach the bolt and nut securing the left transport wheel in position. See Figure 30.
- B. Remove the wooden block from under the unit.

11. Test the unit for proper operation.

- A. Connect the power cord into the power outlet.
- B. Turn the main power switch above the power inlet to the on (I) position.
- C. Operate the unit at all levels to verify proper operation.

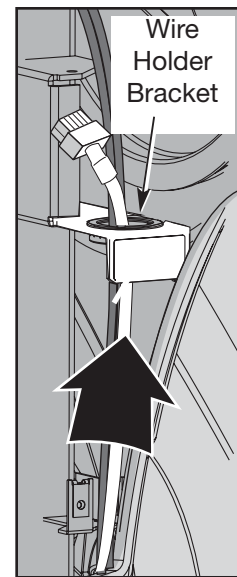

Figure 35

Display Overlays

NOTE: This procedure will cover the upper and/or lower display overlay. They are removed and replaced the same.

Tools Required

- Phillips head screwdriver
- ESD (Electro Static Discharge) grounding strap
- Razor blade

1. Disconnect the external power source.

- A. Turn the main power switch above the power inlet to the off (O) position.
- B. Unplug the power cord from the power outlet.

NOTE: Wear an ESD strap for the rest of this procedure.

2. Remove the top console front.

- A. Using a Phillips head screwdriver, remove the screw securing the access cover to the console back. See Figure 27.
- B. Using a Phillips head screwdriver, remove the four screws securing the console front to the console back.
- C. Gently pull the console front forward and disconnect these cables from the display board: the display cables; the contact heart rate cables; ground wire and the polar heartrate cable. See Figure 28.
- D. Using a Philips head screwdriver, remove the five display board mounting screws.
- E. Lift and rotate the display board to the right and unplug the three overlay ribbon cables from the display board. Set the display board aside.

3. Remove the display overlays.

- A. Use a razor blade to peel up a corner of the upper and lower display overlays and pull off the overlays.

4. Attach the display overlays.

- A. Remove the paper backing from the new display overlays.
- B. Slide the ribbon cable through the slot.
- C. Carefully place the display overlays in place within the indentation on the console front.
- D. Firmly rub the display overlays so that it adheres to the console.

5. Attach the display board.

- A. Plug the overlay ribbon cables into the appropriate connectors in the display board.

- B.** Place the display board in position and secure with five mounting screws removed in step 2D.
- C.** Place the console front in position and connect these cables to the display board: the display cables; the contact heart rate cables; ground wire and the polar heartrate cable. See Figure 28.

6. Attach the console front.

- A.** While being sure not to pinch any cables, secure the console front to the console back with the four Phillips head screws removed in step 2B.

7. Attach the access cover.

- A.** Using a Phillips head screwdriver, secure the access cover to the console back with the screw removed in step 2A. See Figure 27.

8. Test the new display overlay.

- A.** Turn the main power switch to the on (I) position.
- B.** Plug the unit into the power outlet.
- C.** Try each key to be sure that it functions properly.