



AT555

Auto Tonometer

Service Manual

TABLE OF CONTENTS

Introduction	4
Reichert Assistance	4
Warnings & Cautions	5
Theory of Operation	6
Troubleshooting	
Error Codes (13910 & 13911 Only)	10
Error Codes (13912 Only).....	12
Error Code Table	10
System Errors	14
Testing	
Introduction	16
Special Tools & Equipment	16
LCD Brightness Adjustment	17
LCD Contrast Adjustment	17
Test Point Voltages	18
Calibration	
Special Tools and Equipment	29
Pressure Delivery (Ramp) Calibration:	30
Fixation Alignment	30
Optical Alignment.....	31
Fire Around	32
Tonometer Alignment.....	33
Rubber Eye Calibration	33
Final Checks	35
Cleaning	
Introduction	36
Special Tools & Equipment	36
Warnings & Cautions	36
Alignment Window Cleaning Procedure	36
Air Tube Cleaning	36
External Cleaning Procedure	36
General Disassembly	37
Repairs	
Introduction	38
Special Tools & Equipment.....	38
Warnings & Cautions	38
Repair 1 Nosepiece Cover Replacement.....	39
Repair 2 Printer Door Latch Replacement	39
Repair 3 Printer Replacement	40
Repair 4 Power I/O Circuit Board Replacement (13910 & 13911 Only)	41
Repair 4A Power I/O Circuit Board Replacement (13912 Only)	42
Repair 5 Control Circuit Board Replacement (13910 & 13911 Only).....	44
Repair 6 Motor Circuit Board Replacement	44
Repair 7 LCD Screen Replacement	45
General Assembly	46
Appendix A - General Specifications	47
Appendix B - Harness Connection List	48
Appendix C - Software Revision List	50
Appendix D - Rubber Eye Cleaning Procedure	51

LIST OF FIGURES

<i>Figure #</i>	<i>Description</i>	<i>Page#</i>
OP-1.	Alignment System	7
OP-2.	Measurement System	9
TT-1.	LCD P/N 13960-966	17
TT-2.	LCD P/N 13900-403	17
TT-3.	Power Input / Output Circuit Board Layout (Model 13910 & 13911 Only)	21
TT-3A.	Power Input / Output Circuit Board Layout (Model 13912 Only).....	22
TT-4.	Power Input / Output Block Diagram (Model 13910 & 13911 Only).....	23
TT-4A.	Power Input / Output Block Diagram (Model 13912 Only)	24
TT-5.	Main Control Circuit Board Layout	25
TT-6.	Main Control Block Diagram	26
TT-7.	Motor Control Circuit Board Layout	27
TT-8.	Motor Control Block Diagram	28
CT-1.	Pressure -vs- Time Waveform	30
CT-2.	Solenoid Current Adjustment Potentiometer	30
CT-3.	Fixation Spot	30
CT-4.	Fixation Spot Shadow	30
CT-5.	Glass Eye Fixture Installed	31
CT-6.	Alignment Targets and Squares	31
CT-7.	Tonometer Head Parts Identification	31
CT-8.	Rubber Eye Fixture	32
CT-9.	Selection of Applanation Graph	32
CT-10.	Applanation Gain Screen	33
CT-11.	Rubber Eye Setup	34
CT-12.	Rubber Eye Calibration Screen	34
CL-1.	Rear Mask Windows	36
DS-1.	Left/Right Headrest Removal	37
DS-2.	Disconnect Left/Right Harness	37
DS-3.	Top Cover Screws Removal	37
DS-4.	Lower Side Cover Screws	37
DS-5.	Upper Side Cover Screws	37
R1-1.	Nosepiece Cover Removal	39
R2-1.	Latch Fingers	39
R2-2.	Latch Removal	39
R3-1.	Printer Parts ID	40
R3-2.	Printer Removal Step 1	40
R3-3.	Printer Removal Step 2	40
R3-4.	Printer Removal Step 3	40
R4-1.	Connector Locations (Models 13910 & 13911 Only)	41
R4-2.	Connector Locations (Model 13912 Only)	43
AS-1.	Lower Side Cover Screws	46
AS-2.	Upper Side Cover Screws	46
AS-3.	Wire Harness Retaining Clip.....	46
AS-4.	Top Cover Alignment	46
AS-5.	Top Cover Screws Installation	46
AS-6.	Headrest Installation	46

INTRODUCTION

This document contains the instructions for performance, repair, calibration, and alignment of the AT555 Auto Tonometer (catalog items 13910, 13911, and 13912). The Service Software for the calibration and alignment procedures in this manual is provided on; a PCMIA card (P/N 13900-954) for catalog items 13910 and 13911, and is part of the unit software for the 13912 catalog number.

The information provided in this document has been prepared for trained service technicians who have attended the training course for ophthalmic instruments given by Reichert, Inc.

Reichert Assistance

The following list contains telephone numbers for the customer service personnel at Reichert, Inc. and the shipping address. If you have questions regarding this document, please contact a technical support representative as indicated below.

Customer Service:

Marie Valentine (716) 686-4582

Christine Newton (716) 686-4553

Fax:(716) 686-4555

Technical Support:

Ray Halbert (716) 686-4584

Fax: (716) 686-4545

Main Switchboard

Receptionist (716) 686-4500

Shipping Address:

Reichert, Inc.

3374 Walden Ave.

Depew, NY 14043

© 2005 Reichert, Inc.

All rights reserved.

WARNINGS & CAUTIONS

Reichert, Inc. is not responsible for the safety and reliability of this instrument when:

- Assembly, disassembly, repair or modification is made by unauthorized dealers or persons.
- Instrument is not used in accordance with its User's Guide.

Definitions

Warning: An instruction that draws attention to the risk of injury or death.

Caution: An instruction that draws attention to the risk of damage to the product.

- WARNING:** THIS INSTRUMENT IS NOT SUITABLE FOR USE IN THE PRESENCE OF FLAMMABLE ANESTHETIC MIXTURES, SUCH AS OXYGEN OR NITROUS OXIDE.
- CAUTION:** BEFORE TRANSPORTING THE AT555, THE INSTRUMENT MUST BE SET TO THE PARKED POSITION AND THE TRAVEL-LOCK ENGAGED OR DAMAGE TO THE UNIT MAY OCCUR.
- CAUTION:** ANY REPAIR OR SERVICE TO THE AT555 MUST BE PERFORMED BY EXPERIENCED PERSONNEL OR DEALERS WHO ARE TRAINED BY REICHERT, INC. SO THAT CORRECT OPERATION OF THE AT555 IS MAINTAINED.
- CAUTION:** THIS INSTRUMENT HAS ELECTROSTATIC DISCHARGE SENSITIVE DEVICES (ESDS) WHICH ARE SENSITIVE TO STATIC HIGH VOLTAGES STORED IN AND TRANSFERRED BY THE HUMAN BODY. OBSERVE CORRECT ESDS PRECAUTIONS OR PREMATURE MALFUNCTION OF THIS INSTRUMENT WILL OCCUR.
- CAUTION:** MAKE SURE THAT THE VOLTAGE APPLIED TO THE UNIT IS THE SAME AS THE VOLTAGE THAT IS GIVEN ON THE DATA PLATE NEXT TO THE INPUT CORD RECEPTACLE OR DAMAGE TO THE UNIT MAY OCCUR.
- CAUTION:** THIS INSTRUMENT MUST BE PLUGGED INTO AN OUTLET WITH AN EARTH GROUND THAT IS CONNECTED TO THE RECEPTACLE OR DAMAGE TO THE UNIT MAY OCCUR. DO NOT DISABLE OR REMOVE THE GROUND PIN.
- CAUTION:** USE ONLY A 13717 CALIBRATED RUBBER EYE FIXTURE THAT HAS BEEN VERIFIED FOR ACCURACY AT THE REICHERT FACTORY WITHIN THE LAST 6 MONTHS OR INCORRECT CALIBRATION MAY RESULT.
- CAUTION:** DO NOT USE SOLVENTS OR STRONG CLEANING SOLUTIONS ON ANY PART OF THIS INSTRUMENT OR DAMAGE TO THE UNIT MAY OCCUR.
- CAUTION:** USE OF ALCOHOL ON THE LIQUID CRYSTAL DISPLAY (LCD) MAY CAUSE DAMAGE TO THE DISPLAY.

THEORY OF OPERATION

AT555 Introduction

The AT555 is an advanced electronic tonometer that acquires IOP (Intraocular Pressure) data from the eye and also contains an innovative automated alignment system that quickly aligns itself to the patient during the measurement process.

Special Features of the AT555

The AT555 has special features that are not available on other tonometers. The AT555 features are: a Sliding Headrest Assembly for easier patient positioning, and an auto alignment system. Additional features contained in this instrument are a Travel Lock Assembly and an illuminated nosepiece assembly. The special features of the AT555 are described below.

Sliding headrest Assembly

The AT555 utilizes a translating headrest assembly which when positioned to the left or right, aids with the correct positioning of the patient and automatically displays left or right on the LCD.

Auto Alignment System

Our patented "hands-free" auto-alignment technology in this instrument removes the necessity to adjust any joystick or chin rest. After the patient is positioned correctly, the operator initiates the measurement process by pressing the Measure button. The AT555 then automatically aligns itself in front of the eye and acquires the data.

Left / Right Detector

Each instrument contains a Left / Right detector that automatically detects which eye the instrument is measuring. When the headrest is positioned to the left or right, the LCD displays the appropriate left or right eye.

Travel Lock Assembly

A travel lock assembly is provided with the instrument to secure the positioning system during transportation. This assembly ensures that during transportation, the operational integrity of the instrument is maintained.

Illuminated Nosepiece Assembly

An illuminated nosepiece was designed into this instrument to assist with patient alignment. When this assembly is utilized, the patient quickly aligns themselves to the instrument.

Positioning System Operation

The new AT555 optimizes the alignment of the patient to the optical system without the use of a joystick or the necessity of a chin rest. The patient locates the red illuminated nosepiece, observes the green fixation target inside the illuminated nosepiece, and then slowly leans against the headrest while observing the green target. After the patient is positioned correctly, the operator initiates the measurement process by pressing the Measure button. The measurement process then automatically aligns and acquires the eye data quickly and accurately. During the entire measurement process, the alignment system verifies the correct position of the patient to ensure that correct positioning is maintained for accurate measurement data. Refer to Figure OP-1 for a block diagram of the Alignment System.

Details of the Alignment System

The auto-alignment system of the auto-tonometer uses two positioning LEDs (wavelength = 875 nm) and two receiving cameras as the main components of the alignment system. When a measurement is requested by an input from the operator (button push) the Motor Control Board applies power to the right Position LED. The LED emits light toward the eye. Some of the emitted light reaches the eye and is reflected off the cornea and is sent to the 1st Surface Mirror on the opposite side. This light is then reflected off of the mirror and continues on through the IR Filter, Position Lens, Spacer Lens and finally to the Position LED Camera. The Position LED Camera receives the light source data and converts it to electronic data. This converted data is sent to the Video Circuit Board, Control Board, I/O Board, and Motor Board where it is processed using a proprietary processing technique (a process for which patents have been issued) to provide precise alignment of the system to the eye.

After the right side Position LED Camera receives its data, the left side Position LED and camera alternately turns on and acquires its data. The right and left side Position LED's are alternately activated to allow for three dimensional positioning.

THEORY OF OPERATION (CONTINUED)

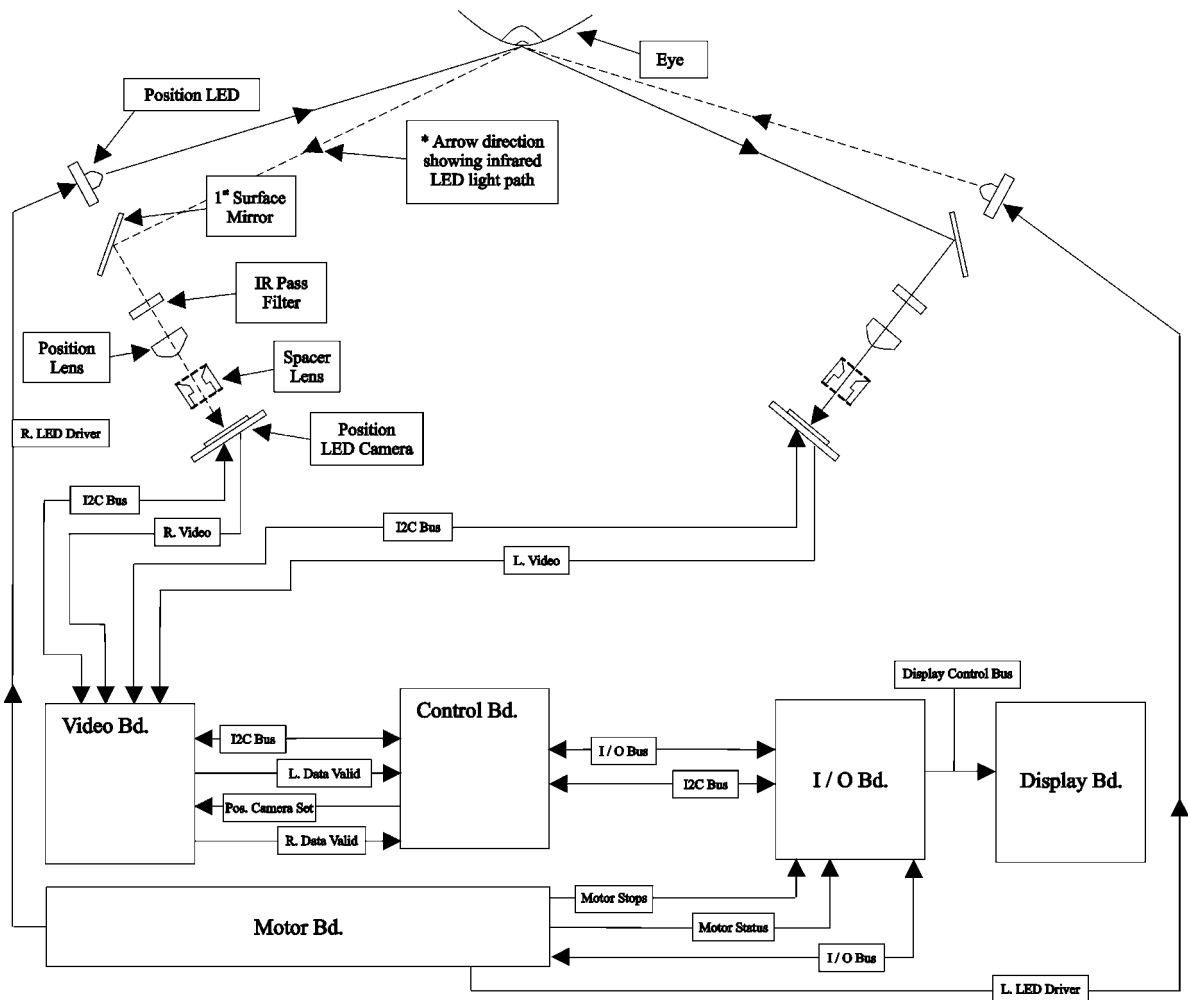

Figure OP-1. Alignment System

THEORY OF OPERATION (CONTINUED)

Air Puff System

The AT555 air puff system produces a small puff of ambient air from the air tube when the patient is fully aligned in front of the instrument. This puff of air is directed at the center of the cornea, and when aligned, causes the cornea to applanate. When the cornea has applanated, the tonometer records the pressure and displays the IOP on the LCD screen. The air puff system consists of a piston within a stainless steel cylinder, an electronic drive for the piston assembly, and an airtube assembly (referred to as the nosepiece assembly). The piston and electronic drive provide the force to push the air out of the air tube. The nosepiece assembly combines the air puff, pressure monitoring, applanation detection and the proximity detection functions together which enable a closed loop delivery system.

When the patient is positioned correctly in front of the air tube and the measure button is activated, the AT555 automatically aligns to the center of the cornea and the piston is energized. After the air is delivered to the cornea and the cornea has applanated, light from the emitter diode is sensed by the detector. When the detector has reached its highest output signal (applanation of the eye), the solenoid drive to the piston immediately stops and air pressure quickly ramps down. When the retaining spring attached to the piston overcomes the ramp down pressure, the retaining spring returns the piston to its original position.

The manifold attached to the back of the airtube monitors the pressure when applanation occurs and the pressure is recorded. This pressure is proportional to the force required to applanate the cornea. From this pressure, the intraocular pressure (IOP) is calculated and it is then displayed on the Liquid Crystal Display (LCD).

Applanation System

The applanation system consists of an infrared emitter (875 nm) and detector placed so that the energy from the emitter is directed obliquely toward the cornea. The detector is placed tangentially from the emitter so that light reflected from the flattened cornea will be directed to the detector. An undisturbed cornea (non-applanated) will direct very little amounts of infrared light toward the detector. As the curvature of the cornea starts to applanate by the air pulse, the infrared light increases to the detector until a maximum level is detected at the exact instant of flattening (e.g., applanation). This is followed by a rapid decrease in the amount of infrared light detected as the cornea becomes slightly concave. At the exact instant of applanation, the pressure is recorded and the IOP reading is displayed on the LCD screen.

Proximity Detector

The proximity detector is a sensor that is attached to the end of the air tube. This circuit prohibits the air tube from contacting the eye.

This circuit contains an oscillator and its associated circuitry to detect external capacitance (the human body or an eye which is within approximately 1/4" of the cornea) near the airtube. This circuit contains a copper ring and two semicircular rings surrounding the end of the air tube. The capacitance between these rings will change with regards to body capacitance. If the patient's eye is too close to the end of the air tube, the circuit will detect a large change in the body capacitance and the proximity detector will disable the motor drive circuitry in the forward direction. After the motors are disabled in the forward direction the positioning system resets to the home position. After the position system returns to the home position, the instrument will try to position in front of the eye and take a another reading.

The instrument will try a maximum of three times to take a reading and if all three times the too close sensor is activated, the instrument will return to the menu choice that requires the measure button depressed to initiate another measurement.

Target Illuminator

The target illuminator is a visible target that the patient utilizes to align their eye to the instrument. This target is located on the nosepiece assembly at the rear side of the air tube. During alignment of the patient to the instrument, the patient initially finds the green target, then moves forward to place their head against the headrest. Once against the headrest, the instrument quickly finds the eye and takes a measurement.

Touch Sensor

This instrument contains a touch sensor that will stop all motion of the alignment system when activated. If someone (e.g., patient) touches the inside edge of the touch plate (grey plate which surrounds the nosepiece cover) the message "Touch Sensor Activated" will appear and the alignment system will stop its movement. After the alignment system stops, it will then retract to the home position.

THEORY OF OPERATION (CONTINUED)

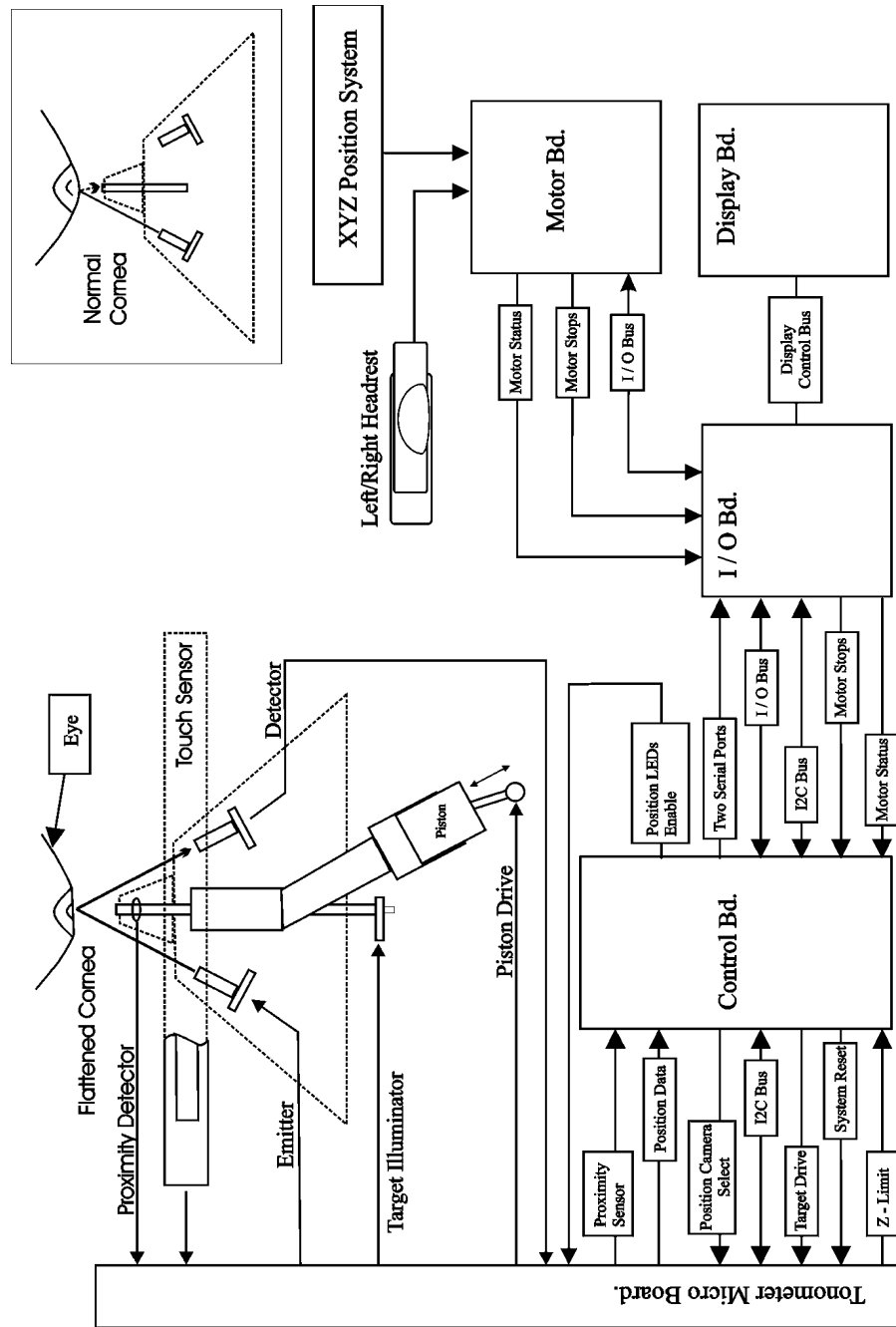

Figure OP-2. Measurement System

TROUBLESHOOTING

The following lists provide suggestions for fault conditions:

- Note: Reference to a Harness Connection List is given in [Appendix B](#).
- Note: To provide concise information on specific parts, assemblies, and/or connector designators (e.g., P1) they are indicated and followed by the associated Parts Manual figure and item number (e.g., Fig.4,27).
- Note: Error Codes caused by components within the Optical Head Assembly (Fig.4,7) require replacement of the complete Optical Head Assembly and will only reference the replacement assembly. However, if an error code can be caused by a disconnected connector within the Optical Head assembly, reference to that connector is also given.

Error Codes

This instrument is designed to display error codes when a malfunction has occurred. The error codes aid the technician to isolate the cause of malfunctions. Causes are listed in sequence of probability (first probable cause listed is the most likely cause or the easiest to test). The following list contains the error codes and their definition:

Note: When Error Codes are displayed it is suggested that the instrument be “re-booted” (remove input power and then re-apply input power) as the Error Code may be the result of a computer “glitch.” If after input power is reset and the unit continues to display the Error Code, continue to the Error Code Table and check the probable cause.

Error Code Table (Models 13910 and 13911 only)

<u>Code#</u>	<u>Definition</u>	<u>Probable Cause</u>
1	CPU diagnostic failed.....	Defective Control Board (Fig.4,12)
2	RAM diagnostic failed	Defective Control Board (Fig.4,12)
3	PROM diagnostic failed	Defective Control Board (Fig.4,12)
4	NVRAM diagnostic failed	Defective Control Board (Fig.4,12)
5	EEPROM diagnostic failed.....	Defective Optical Head Assy (Fig.4,7)
6	X motor failed.....	J1 (Fig.5,35) Disc'd J8, J10, or J12 (Fig.5,35) Disc'd X,Y,Z Motor Connectors Interchanged U5, U6, U7 (Fig.5,35) FPGA Chip Not Seated Properly Defective Motor Data Cable Harness (Fig.4,21) Defective Motor Board (Fig.5,35) Defective Power I/O Board (Fig.4,27)
7	Y motor failed.....	Same as Error Code 6
8	Z motor failed.....	Same as Error Code 6
9	System failed to home motors	Same as “Disengage Travel Lock” in this section
10	Travel lock is engaged.....	Same as “Disengage Travel Lock” in this section
11	System failed to park motors	Same as “Disengage Travel Lock” in this section
12	Stray light has been detected	Not used in this instrument
13	Positioning motor error.....	J1 (Fig.5,35) Disc'd Same as Error Code 7
14	Left VVL camera error.....	J2 (Fig.4,15) Disc'd Software incompatibility issue. J1 (Fig.4,7) Disc'd J8 (Fig.4,7) Disc'd Defective Optical Head Assembly

- Continued on next page -

TROUBLESHOOTING (CONTINUED)

Error Code Table (Models 13910 and 13911 only) (Continued)

<u>Code#</u>	<u>Definition</u>	<u>Probable Cause</u>
15	Right VVL camera error	J2 (Fig.4,15) Disc'd Software incompatibility issue. J2 (Fig.4,7) Disc'd J8 (Fig.4,7) Disc'd Defective Optical Head Assembly
16	Undefined.....	Not used in this instrument
17	Tonometer Subsystem Error	Defective Tonometer Circuit Board, replace the Optical Head Assembly (Fig.4,7)
18	Positioning Subsystem Error.....	J2 (Fig.4,15) Disc'd Software incompatibility issue. J1 (Fig.4,7) Disc'd J2 (Fig.4,7) Disc'd J8 (Fig.4,7) Disc'd Defective Optical Head Assembly
19	Undefined.....	Not used in this instrument
20	DAC error	Defective Tonometer Circuit Board, replace the Optical Head Assembly (Fig.4,7)
21	I ² C bus error.....	J2 (Fig.4,15) Disc'd J7 (Fig.4,7) Disc'd J8 (Fig.4,7) Disc'd
22	X MOTOR Homing STARTUP ERROR	Motor board (Fig.5,35) or Main power I/O board (Fig.4,27) defective.
23	Y MOTOR Homing STARTUP ERROR	Motor board (Fig.5,35) or Main power I/O board (Fig.4,27) defective.
24	Z MOTOR Homing STARTUP ERROR	Motor board (Fig.5,35) or Main power I/O board (Fig.4,27) defective.
25	X MOTOR Homing IN ERROR	Motor (Fig.5,16) or position sensor (Fig.5,12) defective or mechanical interference with movement in the RIGHT direction.
26	Y MOTOR Homing IN ERROR	Motor (Fig.5,16) or position sensor (Fig.5,12) defective or mechanical interference with movement in the UP direction.
27	Z MOTOR Homing IN ERROR	Motor (Fig.5,16) or position sensor (Fig.5,12) defective or mechanical interference with movement in the operator's direction.
28	X MOTOR Homing OUT ERROR	Motor (Fig.5,16) or position sensor (Fig.5,12) defective or mechanical interference with movement in the LEFT direction.
29	Y MOTOR Homing OUT ERROR	Motor (Fig.5,16) or position sensor (Fig.5,12) defective or mechanical interference with movement in the DOWN direction.
30	Z MOTOR Homing OUT ERROR	Motor (Fig.5,16) or position sensor (Fig.5,12) defective or mechanical interference with movement in the patient's direction.

Disc'd = Disconnected or intermittent connections. Check crimp joints and continuity from pin to pin.

Quick Reference Guide

Fig.4,7 = 13910-851 Optical Head Assy
Fig.5,35 = 13900-945 Motor Board Assy
Fig.4,27 = 13910-922 Power I/O Board
Fig.4,12 = 13900-921 Control Board Assy

- Continued on next page -

TROUBLESHOOTING (CONTINUED)

Error Code Table (Model 13912 only)

<u>Code#</u>	<u>Definition</u>	<u>Probable Cause</u>
1	CPU diagnostic failed.....	Defective Main I/O Board (Fig.3A,36)
2	RAM diagnostic failed	Defective Main I/O Board (Fig.3A,36)
3	PROM diagnostic failed	Defective Main I/O Board (Fig.3A,36)
4	NVRAM diagnostic failed	Defective Main I/O Board (Fig.3A,36)
5	EEPROM diagnostic failed.....	Defective Optical Head Assy (Fig.4,7)
6	X motor failed.....	J1 (Fig.5,35) Disc'd J8, J10, or J12 (Fig.5,35) Disc'd X,Y,Z Motor Connectors Interchanged U5, U6, U7 (Fig.5,35) FPGA Chip Not Seated Properly Defective Motor Data Cable Harness (Fig.3A,44) Defective Motor Board (Fig.5,35) Defective Main I/O Board (Fig.3A,36)
7	Y motor failed.....	Same as Error Code 6
8	Z motor failed	Same as Error Code 6
9	System failed to home motors	Same as "Disengage Travel Lock" in this section
10	Travel lock is engaged	Same as "Disengage Travel Lock" in this section
11	System failed to park motors	Same as "Disengage Travel Lock" in this section
12	Stray light has been detected	Not used in this instrument
13	Positioning motor error.....	J1 (Fig.5,35) Disc'd Same as Error Code 7
14	Left VVL camera error.....	J2 (Fig.4,15) Disc'd Software incompatibility issue. J1 (Fig.4,7) Disc'd J8 (Fig.4,7) Disc'd Defective Optical Head Assembly
15	Right VVL camera error	J2 (Fig.4,15) Disc'd Software incompatibility issue. J2 (Fig.4,7) Disc'd J8 (Fig.4,7) Disc'd Defective Optical Head Assembly
16	Undefined.....	Not used in this instrument
17	Tonometer Subsystem Error.....	Defective Tonometer Circuit Board, replace the Optical Head Assembly (Fig.4,7)
18	Positioning Subsystem Error.....	J2 (Fig.3A,45) Disc'd Software incompatibility issue. J1 (Fig.4,7) Disc'd J2 (Fig.4,7) Disc'd J8 (Fig.4,7) Disc'd Defective Optical Head Assembly
19	Undefined.....	Not used in this instrument

- Continued on next page -

TROUBLESHOOTING (CONTINUED)

Error Code Table (Model 13912 only) (Continued)

<u>Code#</u>	<u>Definition</u>	<u>Probable Cause</u>
20	DAC error	Defective Tonometer Circuit Board, replace the Optical Head Assembly (Fig.4,7)
21	I ² C bus error.....	J2 (Fig.3A,45) Disc'd J7 (Fig.4,7) Disc'd J8 (Fig.4,7) Disc'd
22	X MOTOR Homing STARTUP ERROR	Motor board (Fig.5,35) or Main I/O board (Fig.3A,36) defective.
23	Y MOTOR Homing STARTUP ERROR	Motor board (Fig.5,35) or Main I/O board (Fig.3A,36) defective.
24	Z MOTOR Homing STARTUP ERROR	Motor board (Fig.5,35) or Main I/O board (Fig.3A,36) defective.
25	X MOTOR Homing IN ERROR	Motor (Fig.5,16) or position sensor (Fig.5,12) defective or mechanical interference with movement in the RIGHT direction.
26	Y MOTOR Homing IN ERROR	Motor (Fig.5,16) or position sensor (Fig.5,12) defective or mechanical interference with movement in the UP direction.
27	Z MOTOR Homing IN ERROR	Motor (Fig.5,16) or position sensor (Fig.5,12) defective or mechanical interference with movement in the operator's direction.
28	X MOTOR Homing OUT ERROR	Motor (Fig.5,16) or position sensor (Fig.5,12) defective or mechanical interference with movement in the LEFT direction.
29	Y MOTOR Homing OUT ERROR	Motor (Fig.5,16) or position sensor (Fig.5,12) defective or mechanical interference with movement in the DOWN direction.
30	Z MOTOR Homing OUT ERROR	Motor (Fig.5,16) or position sensor (Fig.5,12) defective or mechanical interference with movement in the patient's direction.
31	Press. Transducer Sys. Out > 125 mV	Output of Pressure Transducer @ room temperature is too high. Replace the 13912 Software with rev. 2.3 or greater.
32	Watch Dog not Functioning.....	Malfunction of the Watchdog monitor. Damaged Main I/O board or power supply unit.

Disc'd = Disconnected or intermittent connections. Check crimp joints and continuity from pin to pin.

Quick Reference Guide

Fig.4,7 = 13912-851 Optical Head Assy
Fig.5,35 = 13900-945 Motor Board Assy
Fig.3A,36 = 13912-925 Main I/O Board

TROUBLESHOOTING (CONTINUED)

System Errors

The information in this section will aid the technician to isolate general system malfunctions. Probable causes are listed in sequence of probability (first probable cause listed is the most likely cause or the easiest to test). The following list contains some known System Errors that can occur. This list cannot include all the possible errors for this instrument, however, continuous information will be added at each revision to this manual as it is revised.

Note: To provide concise information on specific parts, assemblies, and/or connector designators (e.g., P1) are indicated and followed by the associated Parts Manual figure and item number (e.g., Fig. 4, 27).

Note: Reference to the Harness Connection List is given in Appendix B.

Miscellaneous System Errors Table (all Models)

<u>Definition</u>	<u>Probable Cause</u>	<u>Solution</u>
Screen Blank	Unit in Sleep Mode. No power applied to unit. Reset Button (Fig.4,28) stuck. Contrast knob turned down. Fuse(s) Blown. Transformer fused winding opened. Switching Power Supply defective J4 (Fig.5,35) Disc'd. J13 (Fig.4,27) Disc'd. Defective LCD Screen Defective Inverter Board	Depress any button. Apply input power. Release stuck button for 13910 and 13911 only. Adjust contrast knob for 13910 and 13911 only. Replace blown fuse(s) (Fig.3A,27) or (Fig.3,30). Replace Transformer (Fig.3,32) (for 13910 and 13911 only) Replace PSU (Fig.3A,37) for 13912 only. Attach connector. Attach connector. Replace LCD Screen (Fig.2,5) Replace Inverter Board (Fig.3A,7) for 13912 only.
Screen Bright with no data showing	Data Cable to LCD Screen not connected.	Reattach connector (Fig.2,7)
Disengage Travel Lock Showing	Travel Lock Engaged. J2, J8, J10, J12 (Fig.5,35) Disc'd. Sensor Flags for the XYZ Home Switch. X,Y, and/or Z positioning motor damaged.	Disengage Travel Lock. Attach connector. Align sensor flags to sensors. Replace defective Sensor Assembly (Fig.5,12) Replace damaged motor (Fig.5,16).
Too Close Message Showing	Eyelashes touching the end of the air-tube.	Have the patient open their eye wide. Defective Too Close sensor board (Fig.9,22) 13910 and 13911 only. Defective Too Close wire (Fig.9,7).
Touch Sensor Message Showing	Touch sensor contaminated. Touch sensor circuit defective.	Clean touch sensor (end of the air-tube) with an alcohol pad. Replace Proximity Board (Fig.9,22) for 13910 and 13911 only. Check connection to Tonometer Board (Fig.8,38) for 13912 only. Check connection of Airtube (Fig.9,7) for 13912. Replace defective Tonometer Board (Fig.8,38) for 13912. only.

- Continued on next page -

TROUBLESHOOTING (CONTINUED)

Miscellaneous System Errors Table (Continued)

<u>Definition</u>	<u>Probable Cause</u>	<u>Solution</u>
Does Not Find the Eye.....	Moves straight out, goes out then straight back (can not find anything).	Ensure light path from VVL diodes (Fig.8,23) to the VVL cameras (Fig.8,52) are unobstructed. Check connection to VVL diodes/cameras. Replace defective diode and/or camera.
Does Not Find the Eye (Cont'd)	External light confusing positioning system.	Isolate sources of external light (incandescent and/or infrared) and remove light source.
Finds one eye not the other	Infrared Light interference on measuring side.	Isolate sources of external light (incandescent and/or infrared) and remove light source.
Tries three times to find the eye	Proximity detector is activated. Proximity Detector	Eliminate touching end of nosepiece. Replace detector circuit.
Will Not Take a Reading	Dirty Position Windows Patient not holding still. Patient's eye too far from Patient Window. Patient not focusing on target (eye moving around). Patient has dry eye.	Clean the optics and airtube as indicated in the <u>Cleaning</u> section of this manual. Encourage patient to remain still. Have patient move toward nosepiece. Have patient look only at target. Have patient blink eyes
Asterisk Readings	Dirty Position Windows Unit needs re-boot of hardware. Unit out of alignment.	Clean the optics and airtube as indicated in the <u>Cleaning</u> section of this manual. Unplug unit, wait 10 seconds then apply input power, then retest. Perform the <u>Calibration</u> procedure as indicated in this manual.
No Applanation Readings	J7,J8 (Fig.4,7) Disc'd or reversed. Unit much out of alignment. Piston not working.	Attach connector. Perform the <u>Calibration</u> procedure as indicated in this manual. Check connection at J13 (Fig.4,7). Replace defective piston/solenoid.
Printer Not Printing.....	Printer out of paper. Cables not connected. Printer not printing characters	Replace paper with P/N 12441. Re-attach J10 and/or J12 (Fig.4,27). Replace print head (Fig.11,1).

Disc'd = Disconnected or intermittent connections. Check crimp joints and continuity from pin to pin.

Quick Reference Guide

Fig.4,7 = 13910-851 Optical Head Assy.
or 13912-851 Optical Head Assy
Fig.5,35 = 13900-945 Motor Board Assy
Fig.4,27 = 13910-922 Power I/O Board
Fig.4,12 = 13900-921 Control Board Assy
Fig.3A,36 = 13912-925 I/O Main PCB

TESTING

Introduction

The following section provides the testing procedures and a troubleshooting guide that gives helpful suggestions when incorrect operation of the AT555 occurs.

A list of general specifications (e.g., size, weight, voltage requirements, etc.) for this instrument is given in [Appendix A](#).

A list of software revisions for this instrument is included in [Appendix C](#).

CAUTION: ANY REPAIR OR SERVICE TO THE AT555 MUST BE PERFORMED BY EXPERIENCED PERSONNEL OR DEALERS THAT ARE TRAINED BY REICHERT, INC. SO THAT CORRECT MEASUREMENT OF THE AT555 IS MAINTAINED.

CAUTION: THE INTERNAL CIRCUITS OF THIS INSTRUMENT HAVE ELECTROSTATIC DISCHARGE SENSITIVE DEVICES (ESDS) AND ARE SENSITIVE TO STATIC HIGH VOLTAGES STORED IN AND TRANSFERRED BY THE HUMAN BODY. OBSERVE CORRECT ESDS PRECAUTIONS OR PREMATURE MALFUNCTION OF THIS INSTRUMENT WILL OCCUR.

Note: Before internal troubleshooting can occur, the top and side covers of the instrument must be removed. Refer to the [Disassembly](#) section of this manual for the details.

Note: The Optical Head Assembly has a warranty seal installed over an attaching screw that secures the optical head cover. Removing the seal from this screw voids warranty, unless pre-authorized from an Reichert Customer Service Representative.

Special Tools & Equipment

The following special tools and equipment are necessary to perform the steps in this section:

Digital Voltmeter (-50 to +50 VDC)

Digital Oscilloscope (Digital Real Time, 1GHz).

TESTING (CONTINUED)

LCD Brightness Adjustment (P/Ns 13910 and 13911 only)

This procedure details the adjustment of the brightness for the LCD backlight. This adjustment is located on the Power Input / Output Board (Fig.4,27) (circuit board on bottom of unit). Refer to Table 1 for the voltages required at TP9. To determine which LCD you have and are replacing, refer to Figures 1 and 2.

Note: For P/N 13912, the brightness and contrast are software controlled and do not require any voltage adjustment.

1. Apply the +probe of a digital voltmeter to TP9 on the bottom circuit board and the -probe to pin 5 of the RS232 connector located next to the input power connector.
2. Adjust R1 until the voltage at TP9 is set as indicated in Table 1 while referencing the correct LCD Assembly.
3. Apply one small drop of enamel paint (e.g., nail polish) to the top of R1 so that it will not be moved accidentally.

LCD Contrast Adjustment (P/Ns 13910 and 13911 only)

This procedure details the adjustment of the LCD contrast control on the Power Input / Output Board. Refer to Table 1 for the voltages required at the test points (TP). To determine which LCD you have or are replacing, refer to Figures 1 and 2.

Note: For P/N 13912, the brightness and contrast are software controlled and do not require any voltage adjustment.

1. Adjust the external contrast knob near the RS232 connector to mid-range.
2. Apply the +probe of a digital voltmeter to TP2 on the bottom circuit board and the -probe to pin 5 of the RS232 connector located next to the input power connector.
3. Adjust R20 until the voltage at TP2 is set as indicated in Table 1 while referencing the correct LCD Assembly.
4. Apply one small drop of enamel paint (e.g., nail polish) to the top of R20 so that it will not be moved accidentally.

LCD Part Number	TP9 (R1)	TP (R20)
13960-966	.085 ±0.03 VDC	-18.0 ±0.2 VDC
13900-403	.075 ±0.03 VDC	-19.5 ±0.2 VDC

Table 1: Test Point Voltages

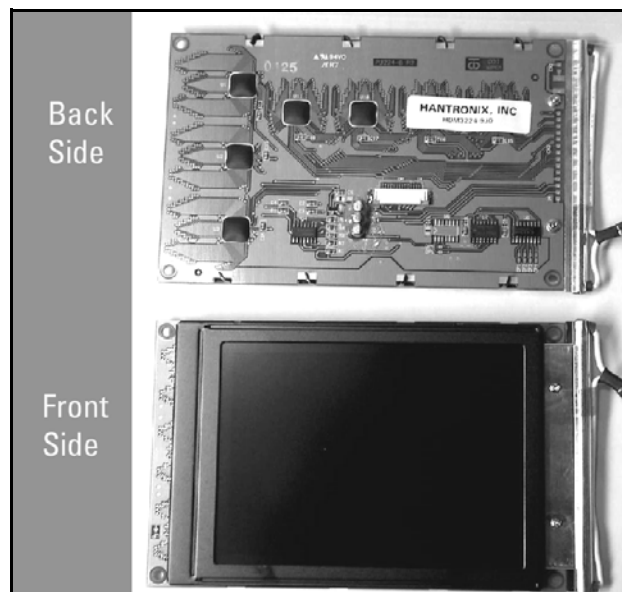

Figure TT-1. LCD P/N 13960-966

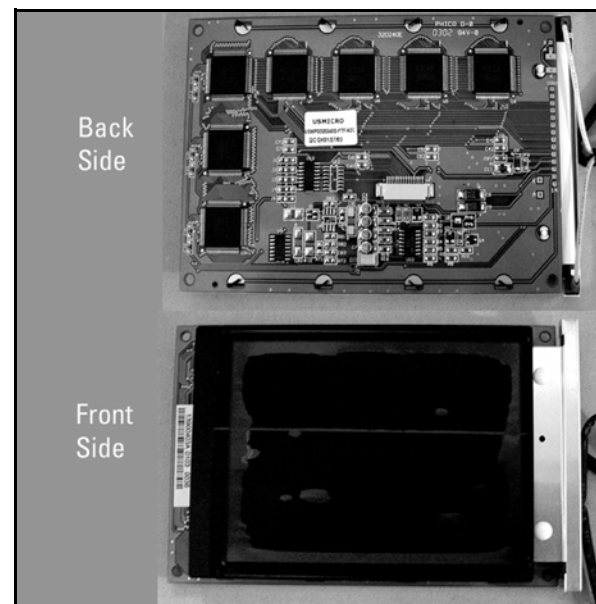

Figure TT-2. LCD P/N 13900-403

TESTING (CONTINUED)

Test Point Voltages

The following information regarding the test points that are located on the circuit boards of this instrument are given as a guide to verify the correct operation of the unit. If special operating conditions are required to observe the references given, effort will be given to provide the necessary information with the appropriate references.

Power Input / Output Circuit Board (Assy 13910-922, Schematic 13910-912). Refer to Figures TT-3 & TT-4. (Models 13910 & 13911 only)

Test Points

TP1 = Test Point 1, +6 Volts peak (half wave) at 50 KHz.

TP2 = Test Point 2, -20.5 VDC (note: LCD screen must be ON). Refer to the Calibration section for voltage level adjustment.

TP9 = Test Point 9, +750 mVDC (note: LCD screen must be ON). Refer to the Calibration section for voltage level adjustment.

TP10 = Test Point 10, Signal Ground (0 VDC)

TP11 = Test Point 11, Vcc Ground (0 VDC)

Note: Pin 5 of the RS232 serial port is also Vcc Ground (0 VDC)

J4 Connector Header

Pin 1 = Vcc Ground (0 VDC)

Pin 7 = -8.0 VDC

Pin 8 = +8.8 VDC

Pin 9 = +8.8 VDC

Misc. Test Points

C60(+) = +15 VDC

CR10(-) = +18 VDC

CR11(+) = -18 VDC

CR12(-) = +Vcc (+5.0 VDC)

Y1 (pin closest to C9) = 8.0 MHz Sinusoid

Voltage at F1 (main fuse on ckt bd) = 14 to 16 VDC

Main Control Circuit Board (Assy 13900-921, Schematic 13900-911). Refer to Figures TT-5 & TT-6. (Models 13910 & 13911 only)

Oscillator Outputs

Y1 = 16.0 MHz (approx 5.5 Vp-p Sinusoid)

Y2 = 3.69 MHz (approx 5.5 Vp-p Sinusoid)

Y3 = 32.8 KHz (approx 1.7 Vp-p Sinusoid)

J1 Connector

Pin B1 = Vcc Ground (0 VDC)

Pin B32 = +5.0 VDC, +Vcc

P1 Connector Header Jumpers

Pin 5 + 6, Watch Dog Disable (used for testing). Should not short pins 5+6 during normal operation.

(Jumper in = Disable, Jumper out = Enable)

Misc. Test Points

CR1 = Red/Green. Green = normal operation, Red = hardware failure or reset.

TESTING (CONTINUED)

Main I/O Circuit Board (Assy 13912-925, Schematic 13880-911). Refer to Figures TT-3A & TT-4A. (Model 13912 only)

Test Points

Y1 = 32.8 kHz (approx 1.7 Vp-p Sinusoid)
Y2 = 3.69 MHz (approx 5.5 Vp-p Sinusoid)
Y3 = 16.0 MHz (approx 5.5 Vp-p Sinusoid)
Y4 = 32.8 KHz (approx 1.7 Vp-p Sinusoid)
Y5 = 16.0 MHz (approx 5.5 Vp-p Sinusoid)

J1 Connector (Tonometer Power)

Pins 1, 2 = +5 VDC
Pin 3 = +18 VDC
Pin 4 = -18 VDC
Pins 5, 6 = GND

J3 Connector (Printer Power)

Pins 1, 2 = +5.0 VDC
Pin 3 = Not Used
Pins 4, 5, 6 = Ground

J10 Input Power Connector

Pin 1 = +18 VDC
Pin 2 = +5 VDC
Pin 3 = +5 VDC
Pin 4 = GND
Pin 5 = GND
Pin 6 = -18 VDC
Pin 7, 8 = Not Used

J11 LCD CCFL Inverter Connector

Pin 1 = +5 VDC
Pin 2 = +5 VDC
Pin 3 = GND
Pin 4 = GND
Pin 5 = Enable (On = 5 VDC)
Pin 6 = Brightness (Dim =) VDC, Bright = 2 VDC)

J12 Connector (Motor Power)

Pins 1, 2 = +5 VDC
Pins 3, 4 = +18 VDC
Pins 5, 6 = GND

J13 RS232C Connector (Serial Port)

Pin 1 = CD OUT
Pin 2 = TXD
Pin 3 = RXD
Pin 4 = Not Used
Pin 5 = GND
Pin 6 = DSR
Pin 7 = RTS
Pin 8 = CTS
Pin 9 = Not Used

TESTING (CONTINUED)

Motor Control Circuit Board (Assy 13900-945, Schematic 13900-946). Refer to Figures TT-7 & TT-8. (All Models)

Test Points

TP1 = Test Point 1, 2.4 KHz Square Wave @ +5.0 VDC p-p, Motor Clock
TP2 = Test Point 2, 2.4 KHz Square Wave @ +3.6 VDC p-p, X-Axis Motor Clock
TP3 = Test Point 3, 2.4 KHz Square Wave @ +3.6 VDC p-p, Y-Axis Motor Clock
TP4 = Test Point 4, 2.4 KHz Square Wave @ +3.6 VDC p-p, Z-Axis Motor Clock
TP5 = Test Point 5, Positioning System Drive Current Sense Voltage
TP6 = Test Point 6, R Motor Drive Current Sense Voltage
TP7 = Test Point 7, X Axis Motor Drive 1 Signal
TP8 = Test Point 8, X Axis Motor Drive 2 Signal
TP9 = Test Point 9, Y Axis Motor Drive 1 Signal
TP10 = Test Point 10, Y Axis Motor Drive 2 Signal
TP11 = Test Point 11, Z Axis Motor Drive 1 Signal
TP12 = Test Point 12, Z Axis Motor Drive 2 Signal
TP13 = Test Point 13, Vcc Ground

J4 Connector, Power Input

Pin 1 = +5.0 VDC, +Vcc Supply Voltage
Pin 2 = +5.0 VDC, +Vcc Supply Voltage
Pin 3 = +18 VDC (during use, +14.0 to +16.0 VDC)
Pin 4 = +18 VDC (during use, +14.0 to +16.0 VDC)
Pin 5 = Ground
Pin 6 = Ground

J13 Connector, Left / Right Detector Circuit

Pin 1 = Right Eye Detect, +5 VDC When ON, 0 VDC When OFF
Pin 2 = Left Eye Detect, +5 VDC When ON, 0 VDC When OFF
Pin 3 = +5 VDC Vcc
Pin 4 = Vcc Ground

TESTING (CONTINUED)

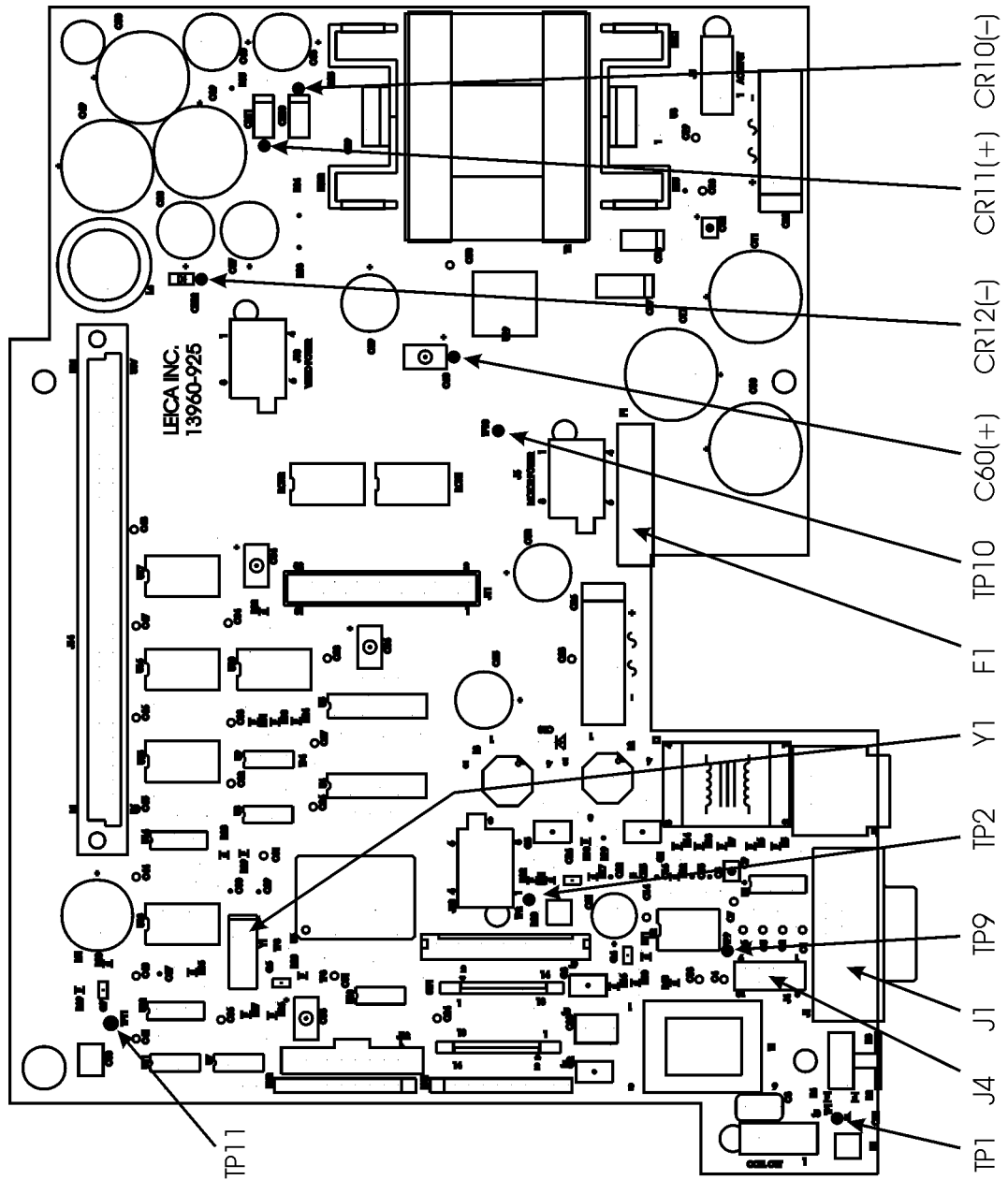
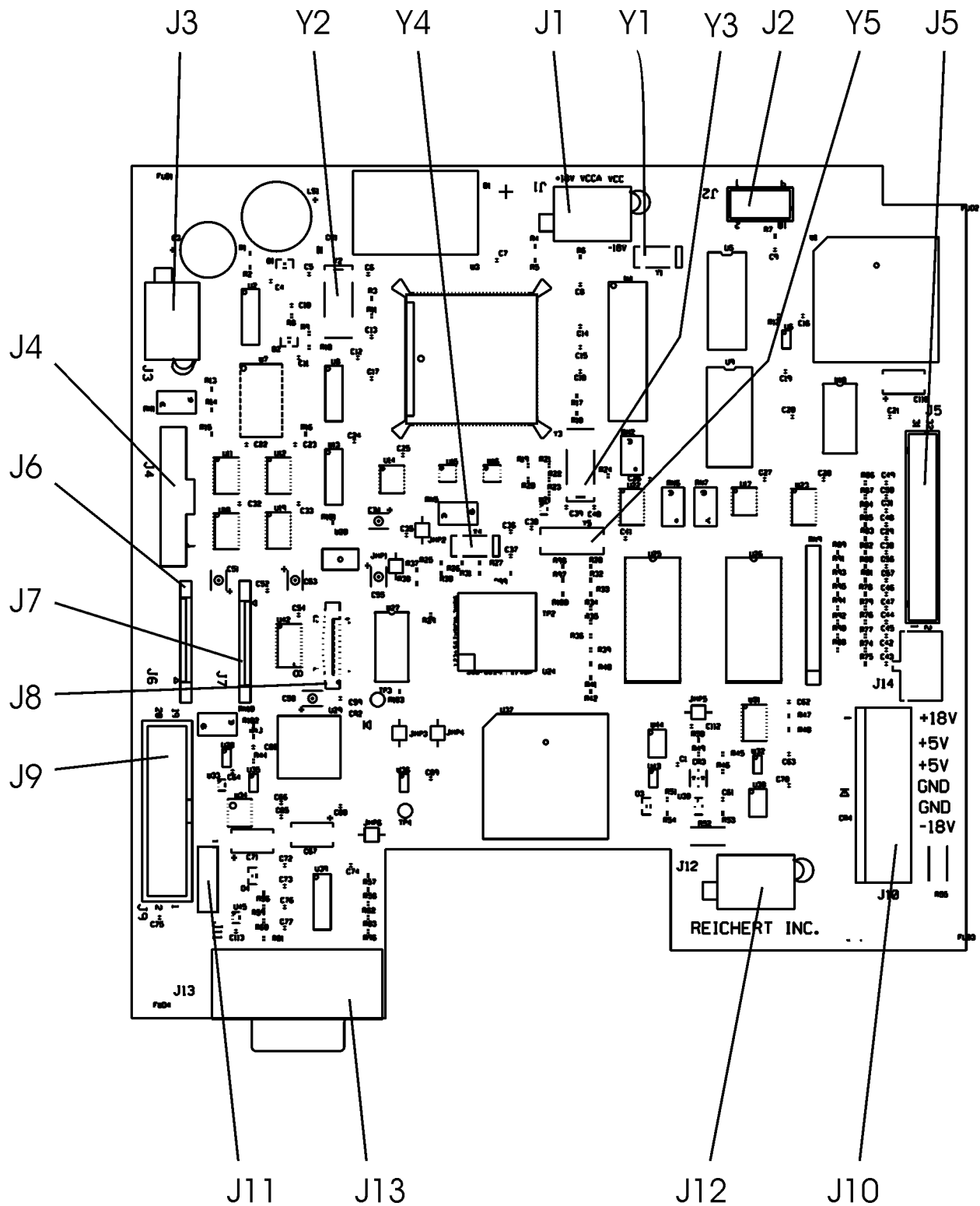

Figure TT-3. Power Input / Output Circuit Board Layout (Models 13910 & 13911 only)

TESTING (CONTINUED)



TESTING (CONTINUED)

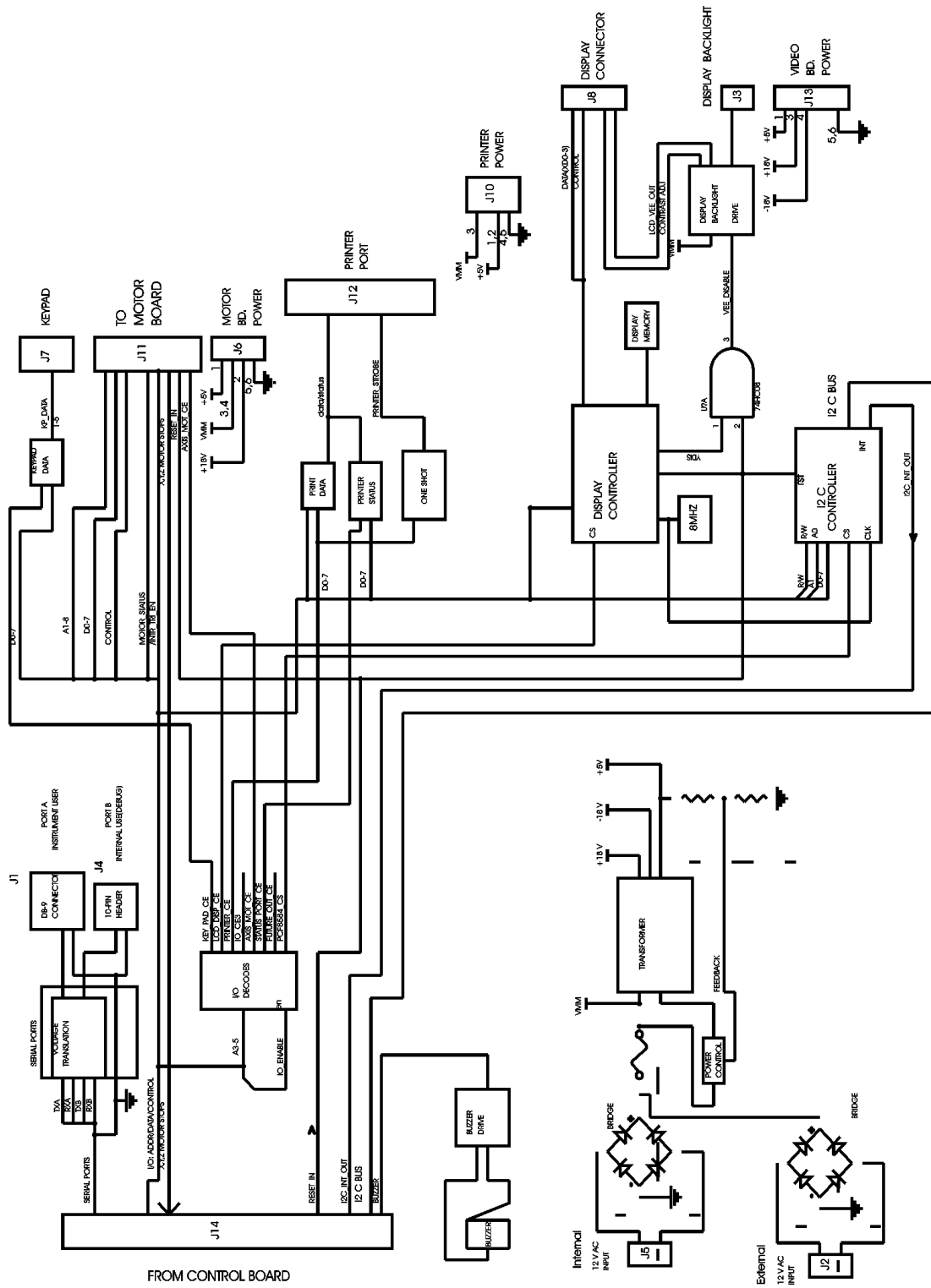

Figure TT-4. Power Input / Output Block Diagram (Models 13910 & 13911 only)

TESTING (CONTINUED)

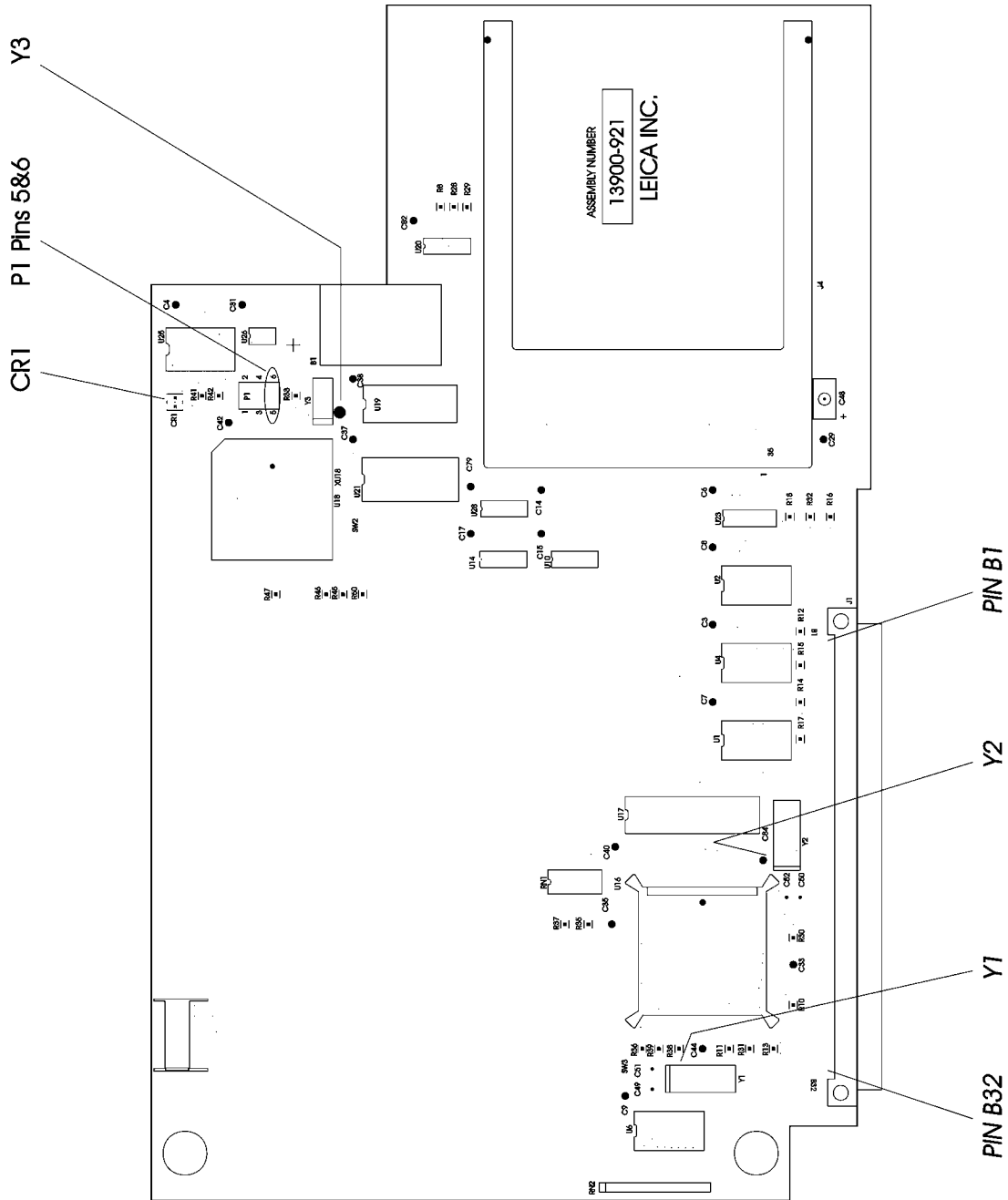

Figure TT-5. Main Control Circuit Board Layout

TESTING (CONTINUED)

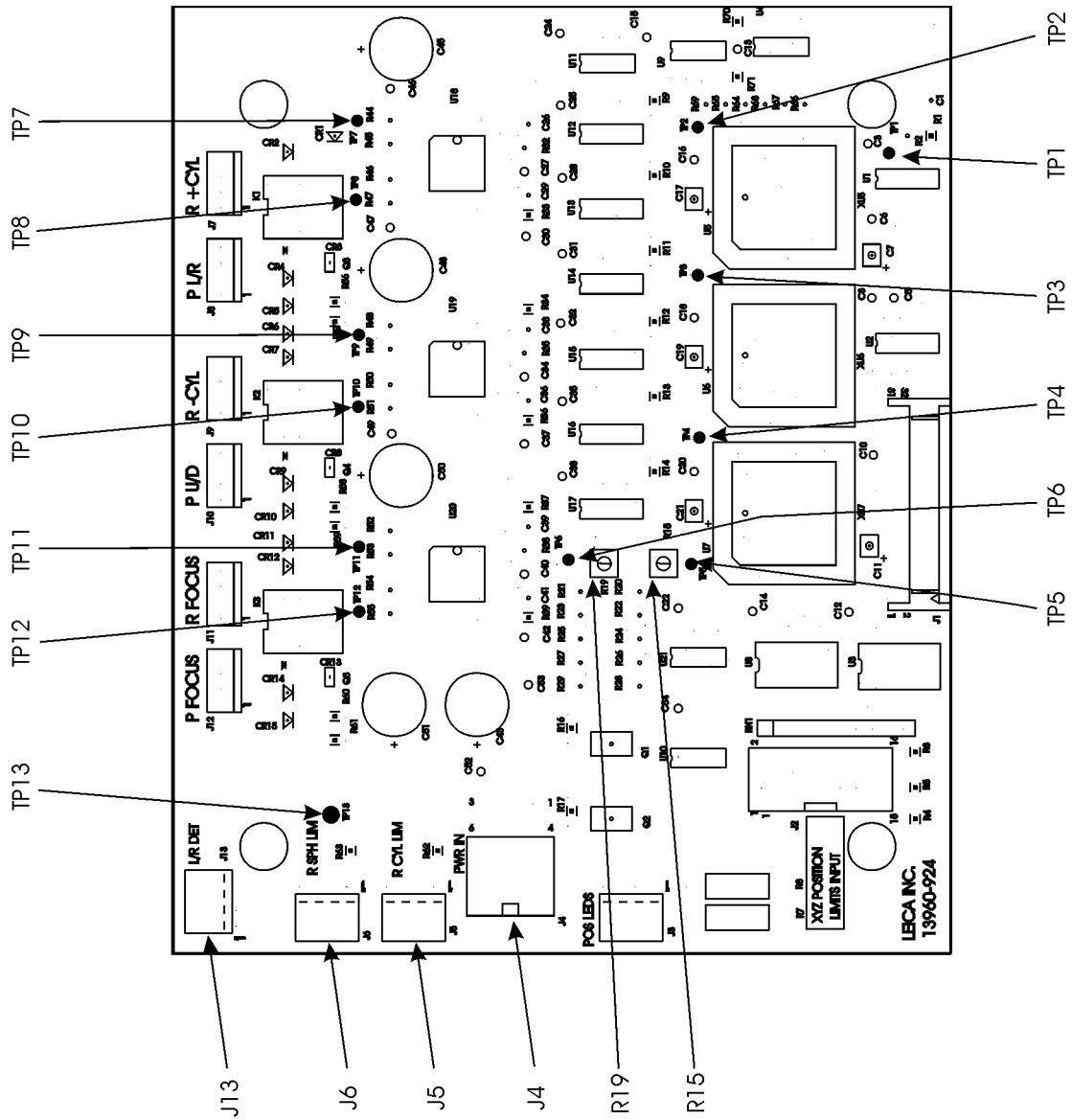

Figure TT-7. Motor Control Circuit Board Layout

TESTING (CONTINUED)

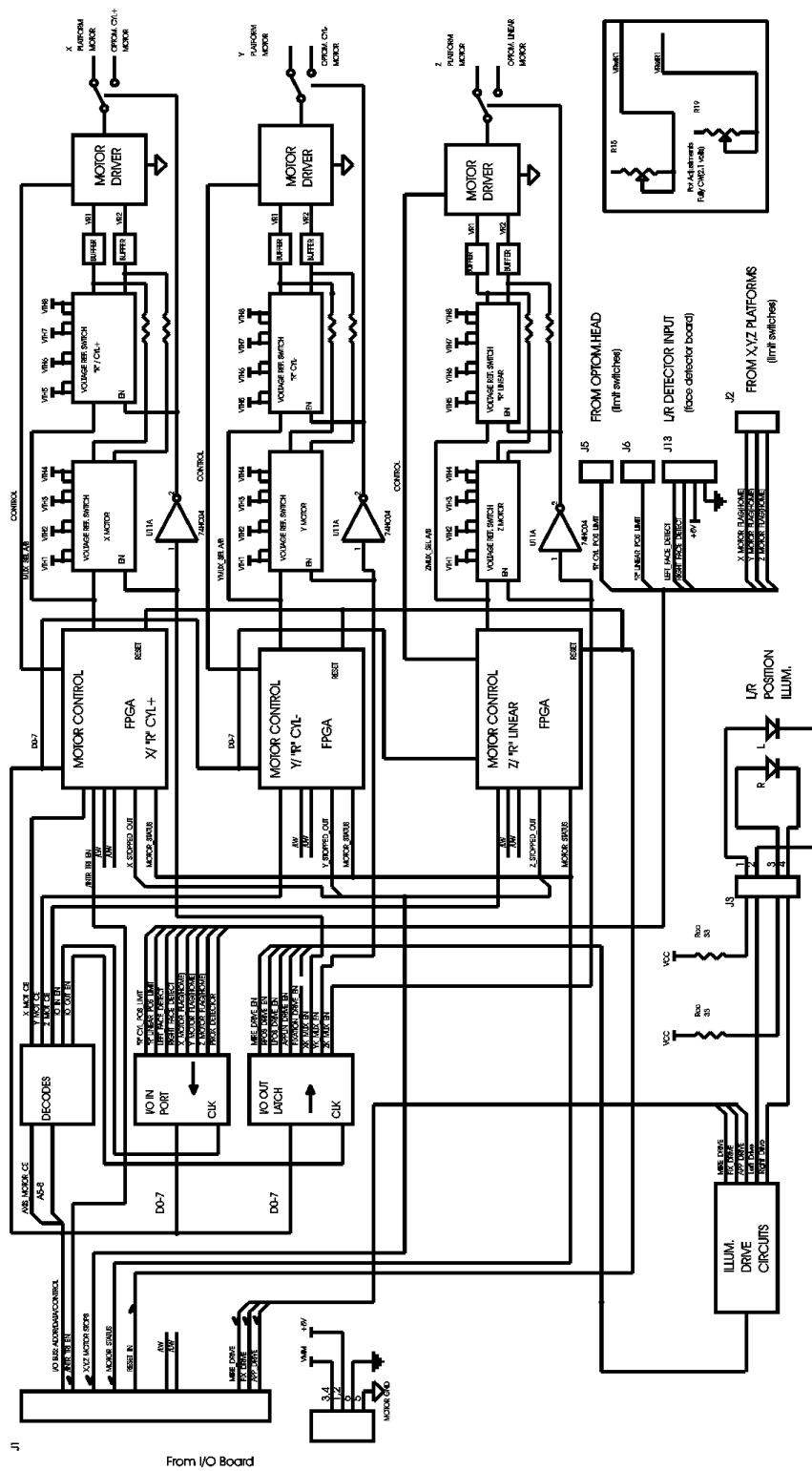

Figure TT-8. Motor Control Block Diagram

CALIBRATION

Special Tools and Equipment

Note: Before performing any calibration of this instrument, it is recommended that you read and fully understand the information provided in this manual.

Note: Before performing any calibration of this instrument, perform the steps in [Disassembly](#).

Note: Attach the Left/Right Harness Assembly to its mating connector from the harness connected to the Motor Control Circuit Board at J13, or the unit will not be able to acquire readings during testing.

The following tools and fixtures are required for performance of the calibration procedures contained in this document.

- Service Software Card (13900-954).
(For Models 13910 and 13911 only)
This software provides the operating protocol when performing the calibration tests.
- Glass Eye (P/N 12430-800B, also part of 13702 kit).
The glass eye is used to set the alignment of the VVL cameras for positioning of the measurement system.
- Rubber eye stand (P/N 13718).
This stand is a support for the t-bar and positions the t-bar to the correct height and angle.
- Rubber Eyes (T-bar P/N 13717).

CAUTION: USE ONLY A 13717 CALIBRATED RUBBER EYE FIXTURE THAT HAS BEEN VERIFIED FOR ACCURACY AT THE REICHERT FACTORY WITHIN THE LAST 6 MONTHS OR INCORRECT CALIBRATION MAY RESULT.

Note: Ensure that the rubber eyes are clean and not damaged. Cleaning instructions were included with the calibrated eyes. If cleaning instructions are not available, refer to [Appendix D](#) in this manual for the rubber eye cleaning procedure.

Procedure

The AT555 measures intraocular pressure (IOP). If calibration of this instrument is required, it is recommended that only personnel who were trained by Reichert, Inc. perform this calibration procedure.

Please follow this procedure in the order given, unless otherwise indicated for calibration of the AT555.

CAUTION: THIS INSTRUMENT HAS ELECTROSTATIC DISCHARGE SENSITIVE DEVICES (ESDS) WHICH ARE SENSITIVE TO STATIC HIGH VOLTAGES STORED IN AND TRANSFERRED BY THE HUMAN BODY. OBSERVE CORRECT ESDS PRECAUTIONS OR PREMATURE MALFUNCTION OF THIS INSTRUMENT WILL OCCUR.

1. Place the instrument in an area that has ESDS protection and observe the appropriate precautions.
2. Apply the correct input power to the unit as shown on the data plate of the unit. When instructed, press any button to continue. Refer to Figure AS-1 for an illustration that shows the location of the Data Plate.
3. Press the button below the MODE icon. Then press the button below the SERVICE icon to access the calibration information. Record the software version, calibration date, and the total number of measurements.
4. Remove the input power to the AT555.
5. For 13910 and 13911 Models Only
 - a. Open the printer door by pushing on it above the printout opening.
 - b. Install the correct version of the Service Software into the PCMIA slot. Refer to the [Special Tools & Equipment](#) section for details of the correct Service Software PCMIA card.
 - c. Align the printer paper in the door slot and close the Printer Door.
 - d. Refer to the [General Disassembly](#) section of this procedure and remove the side and top covers.
 - e. Apply the correct input power to the unit as shown on the data plate of the unit. When instructed, press any button to continue.
 - f. Press the button below the MODE icon. Then press the button below the SERVICE icon to access the Services Menu.
6. For 13912 Models Only
 - a. Press the button below the MODE icon and then press the button below the SERVICE icon.
 - b. Press the button below the SERVICE icon again.
 - c. Enter the password "14213" to enter the calibration mode.

CALIBRATION (CONTINUED)

Pressure Delivery (Ramp) Calibration:

This procedure provides instructions for measurement of the air-puff solenoid drive current.

1. While in the Services Menu screen, press the button below the DOWN ARROW icon until "CAL./VER." is highlighted. Press the button below the SELECT icon.
2. Press the button below the DOWN ARROW icon until "SOLENOID" is highlighted. Press the button below the SELECT icon.
3. After the unit puffs, a graphical representation of the pressure ramp will appear on the screen. The graph line must pass through the "alignment dots" on the screen. Refer to Figure CT-1.

Note: If the applanation curve does not pass through the "dots", remove the Tonometer Head Cover and adjust the potentiometer which is labeled "SOLENOID CURRENT ADJUST" on the tonometer circuit board until the curve passes through the "alignment dots" on the screen as best as fits the curve. To generate a new curve, press the button below the DEMO icon. Repeat as required. Refer to Figure CT-2.

4. Press the button below the RETURN icon.

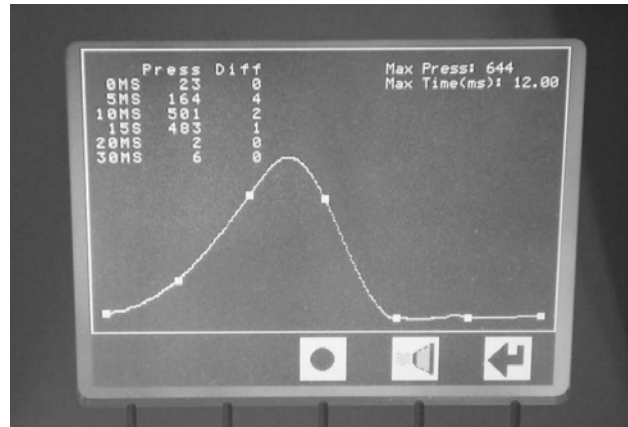

Figure CT-1. Pressure -vs- Time Waveform

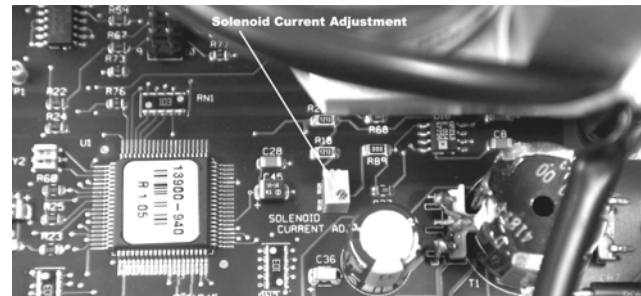

Figure CT-2. Solenoid Current Adjustment Potentiometer

Fixation Alignment

This procedure provides instruction regarding the alignment of the fixation spot that the patient observes during measurement.

View the green fixation spot through the air tube. Refer to Figure CT-3 for an illustration of the fixation spot. This green spot should appear centered and near the back of the tube. If the green spot is not round or has a reflection around the perimeter of the spot, the position of the circuit board must be adjusted.

To adjust the position of the circuit board, perform the following:

1. If the Tonometer Head Cover was not removed, you must remove the cover to perform the steps below.
2. Loosen the 2 screws that secure the fixation PCB assembly to the nosepiece assembly.
3. Look through the airtube assembly and tighten the circuit board when the green spot is round, centered and does not have a reflection. Refer to Figure CT-4.

NOTE: If the green fixation spot cannot be adjusted so that the spot is round and has no reflections, remove the circuit board from the tube housing and slightly adjust the position of the diode towards the direction of the shadow.

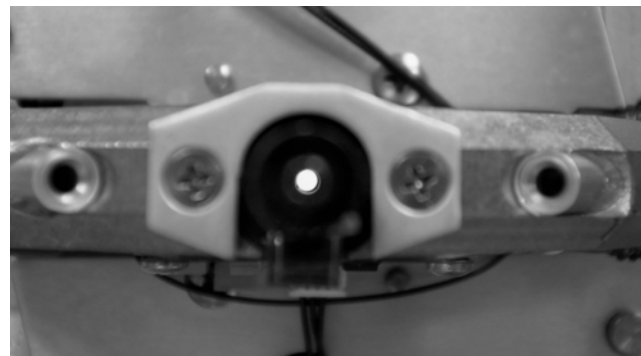

Figure CT-3. Fixation Spot

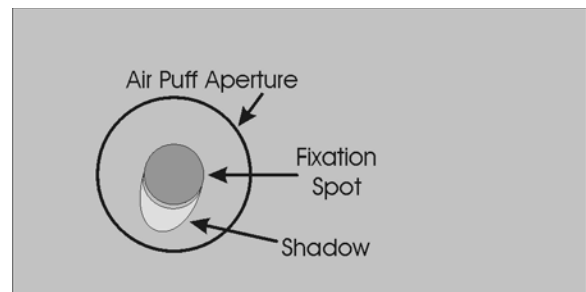

Figure CT-4. Fixation Spot Shadow

CALIBRATION (CONTINUED)

Optical Alignment

This procedure details the steps for performing manual alignment of the optical system. When the square dots, representing the VVL cameras, are within the borders of the target squares the alignment of the system is acceptable.

1. While in the Services Menu screen, press the button below the DOWN icon to highlight the VVL Align test, then press the button below the SELECT icon. The VVL alignment test screen will be active.
2. Install the Glass Eye tool into the end of the air-puff nozzle so that the brass support attached to the shaft of the tool is in the vertical position. Refer to Figure CT-5.
3. The square dots must be within the target squares or improper alignment of the system will occur resulting in incorrect readings, and/or asterisk readings.

Note: If the square dots are within the target squares proceed to the next test in this section.

4. If the square dots are not within the target squares, adjust the position of the VVL cameras until the dots are best centered and within the target squares as follows: (refer to Figure CT-6)
 - a. Remove the four screws that secure the cover to the tonometer head and remove the cover.
 - b. Disconnect the wire harness to the Touch Sensor Plate and remove the plate from the unit.

Note: Do not to loose the plastic isolation bushings or the touch sensor message will appear all the time and the unit will proceed to the measure screen.

- c. Remove the screws that attach the Rear Mask assembly to the unit.
- d. Loosen the two screws on the front of the casting which are on either side of the mirror for the VVL Camera that requires adjustment.
- e. Adjust the position of the VVL (Left or Right) Camera until the square dot is within the target square. When the VVL Camera is within the target squares, tighten the two screws on each side of the mirror to secure the position of the VVL Camera.
- f. Repeat steps d. and e. for the opposite VVL Camera if required.
- g. Repeat steps c thru a in their reverse order for reassembly of this unit and installing the hardware. Torque to approximately 7.0 lbf•in (0.8 N•m).

Note: Only secure the cover to the tonometer head using four screws. The four screws that are to be replaced are located only on the sides. Do not replace the screws across the top of the cover. Discard the extra screws.



Figure CT-5. Glass Eye Fixture Installed

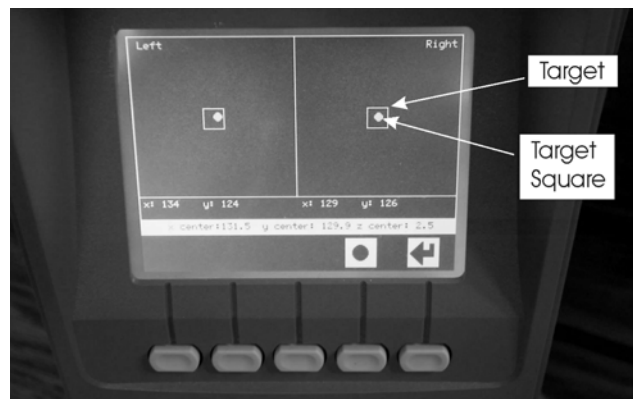

Figure CT-6. Alignment Targets and Squares

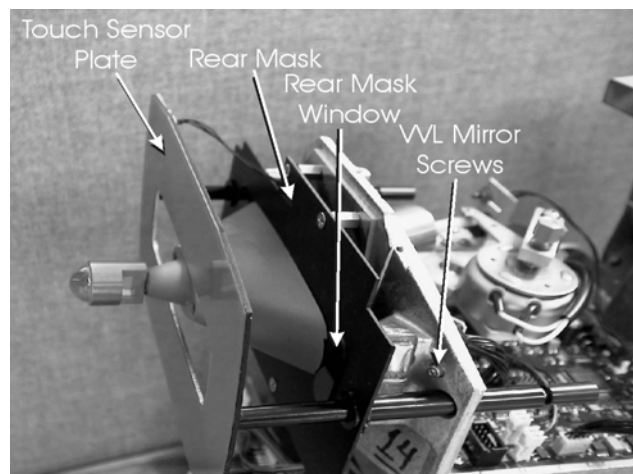

Figure CT-7. Tonometer Head Parts Identification

5. Press the button below the SELECT icon to save the firearound data.
6. Press the button below the RETURN icon to return to the Service Menu screen.
7. Remove the Glass Eye tool from the end of the air-puff nozzle.

CALIBRATION (CONTINUED)

Fire Around

This procedure is used to align the electrical system to the optical system of the AT555.

1. From the Services Menu screen, press the button below the DOWN icon to highlight the Fire test, then press the button below the SELECT icon. The Fire Around Menu will be active.

CAUTION: USE ONLY A 13717 CALIBRATED RUBBER EYE FIXTURE THAT HAS BEEN VERIFIED FOR ACCURACY AT THE REICHERT FACTORY WITHIN THE LAST 6 MONTHS OR INCORRECT CALIBRATION MAY RESULT.

Note: Before starting this test, ensure that the rubber eyes are clean and not damaged. Cleaning instructions were included with the calibrated eyes. If cleaning instructions are not available, please contact customer service as indicated in the [Introduction](#) section of this instruction sheet and one can be sent to you.

2. Install your calibrated set of rubber eyes onto the rubber eye stand and align the middle rubber eye in front of the air-puff nozzle approximately 0.5 to 1.0 inches (1.3 to 2.5 cm) from the end of the nozzle. Refer to Figure CT-8.
3. Press the button below the RIGHT arrow to select the digit that requires modification. Press the button below the + icon until the value is 2.0 steps. Press the button below the MEASURE icon.
4. The AT555 will take nine measurements and then display nine graphs. Use the LEFT and RIGHT arrows and highlight the graph that is symmetrical and has the highest peak amplitude (A). Press the button below the SELECT icon to save the graph position to memory. Refer to Figure CT-9.

Note: If you chose a graph other than the center graph, press the button below the MEASURE icon to repeat the 2.0 step test.

Note: If the instrument does not move and "freezes," then the Too Close sensor has been activated due to the installation of the glass eye into the airtube. If this happens, reboot the unit with the glass eye installed in the airtube.

5. Press the button below the RIGHT arrow to select the digit that requires modification. Press the button below the – icon until the value is 1.0 steps. Press the button below the MEASURE icon.
6. Use the LEFT and RIGHT arrows to highlight the graph that is symmetrical and has the highest peak amplitude (A). Refer to Figure CT-9. Press the button below the SELECT icon to save the graph position to memory.

Note: If you chose a graph other than the center graph, press the button below the MEASURE icon to repeat the 1.0 step test.

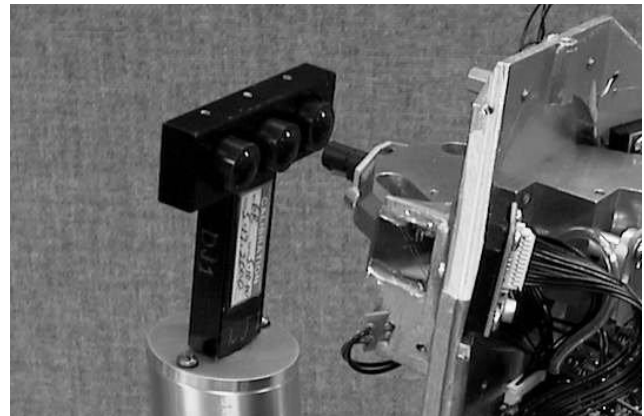

Figure CT-8. Rubber Eye Fixture

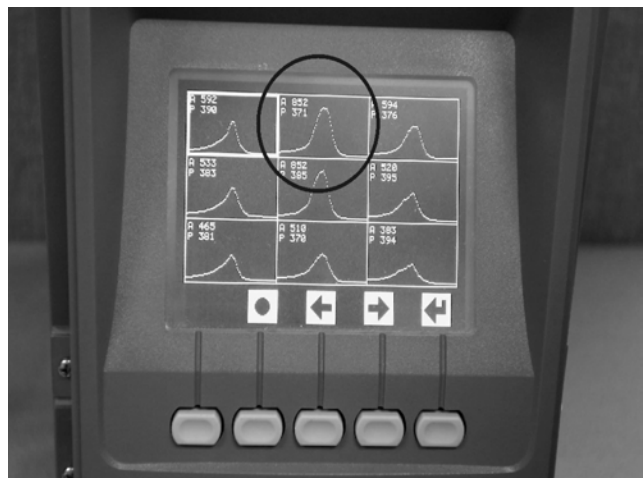

Figure CT-9. Selection of Applanation Graph

7. Press the button below the RIGHT arrow to select the digit that requires modification. Press the button below the – icon until the value is 0.8 steps. Press the button below the MEASURE icon.
8. Use the LEFT and RIGHT arrows to highlight the graph that is symmetrical and has the highest peak amplitude (A). Refer to Figure CT-9. Press the button below the SELECT icon to save the graph position to memory.

Note: If you chose a graph other than the center graph, press the button below the MEASURE icon to repeat the 0.8 step test.

Note: The peak amplitude value (A) of the center graph must not exceed 850.

9. When the center graph is symmetrical and has the highest peak amplitude (A), press the button below the RETURN icon to return to the Services Menu.
10. Keep the rubber eyes in position for the next test.

CALIBRATION (CONTINUED)

Tonometer Alignment

This procedure provides the steps to adjust the gain value for the applanation voltage of the measurement system. A value too high will cause saturation of the peak voltage and a value too low will cause asterisk readings.

Note: This value is set at the factory and will not require modification unless components relating to the applanation gain are replaced and/or damaged.

1. Press the button below the SELECT icon while the Ton Align is highlighted. The tonometer applanation test screen will become active.
2. This screen displays the software controlled Applanation Gain Value. This number (peak amplitude value) may be adjusted using the UP/DOWN arrows after the Optical Alignment and Fire Around tests is performed.

Note: If the Appl. Gain Value is set too high, saturation of the voltage signal may occur and cause inaccurate readings.

3. If the Appl. Gain Value was changed, press the button below the SELECT icon to save the number to memory.
4. Press the button below the RETURN icon to return to the Service Menu screen.
5. Repeat the Fire Around test in this section.



Figure CT-10. Applanation Gain Screen

Rubber Eye Calibration

The rubber eye calibration test sets and/or checks the IOP measurements of the instrument so that it will provide readings within the tolerances of the calibrated rubber eye fixture.

CAUTION: USE ONLY A 13717 CALIBRATED RUBBER EYE FIXTURE THAT HAS BEEN VERIFIED FOR ACCURACY AT THE REICHERT FACTORY WITHIN THE LAST 6 MONTHS OR INCORRECT CALIBRATION MAY RESULT.

Note: Before starting this test, ensure that the rubber eyes are clean and not damaged. Cleaning instructions were included with the calibrated eyes. If cleaning instructions are not available, please contact customer service as indicated in the Introduction section of this instruction sheet and one can be sent to you.

Perform the following:

1. While in the Services Menu screen, press the button below the DOWN icon to highlight the "Cal./Ver." test, then press the button below the SELECT icon. The Calibration Type Menu will be active.
2. Press the button below the DOWN icon to highlight the Eye test, then press the button below the SELECT icon. The Tonometer Calibration screen will be active.
3. Install the set of rubber eyes onto the rubber eye stand and move the low rubber eye in front of the air-puff nozzle on the AT555 approximately 0.5 to 1.0 inches (1.3 to 2.5 cm) from the end of the nozzle. Refer to Figure CT-11.
4. Using the DOWN arrow, highlight the "LOW" menu choice. Then press the button below the SELECT button to activate the menu choice.

Note: If your data sheet does not have a section for the AT555, your rubber eyes are out of date and will require recalibration. DO NOT use the values for the NCTII, Xpert, or the Xpert Plus.

5. Refer to the AT555 section of the data sheet that was provided with the rubber eyes and set the Tonometer Calibration number to be the same as the Rubber Eye Assigned Value. Use the RIGHT arrow to select the digit that requires modification. Press the buttons below the +/- icons to increase (+) or decrease (-) the value.
6. Press the button below the MEASURE icon. The instrument will take 5 measurements.

Note: The measurements may not match the value that was entered for that eye. After all measurements are taken for the three rubber eyes, the instrument will calculate the correct internal values after the calculate button is pressed.

CALIBRATION (CONTINUED)

7. Move the Medium Eye in front of the air-puff nozzle.
8. While in the Tonometer Calibration menu screen, press the DOWN icon button to highlight the Medium eye then press the SELECT button to modify the values for the medium eye. Use the +, -, and the RIGHT buttons to modify the values for the medium eye. When the number is the same as that which is on the Calibration Sheet, press the button below the MEASURE icon. The instrument will take 5 measurements.
9. Move the High Eye in front of the air-puff nozzle.
10. While in the Tonometer Calibration menu screen, press the DOWN icon button to highlight the High eye then press the SELECT button to modify the values for the High eye. Use the +, -, and the RIGHT buttons to modify the values for the High eye. When the number is the same as that which is on the Calibration Sheet, press the button below the MEASURE icon. The instrument will take 5 measurements.
11. After all measurements are taken, press the button below the CALCULATE icon. Refer to Figure CT-12.
12. After the instrument has completed the calculations, press the button below the RETURN icon twice to return to the Services Menu.



Figure CT-11. Rubber Eye Setup



Figure CT-12. Rubber Eye Calibration Screen

CALIBRATION (CONTINUED)

Final Checks

This paragraph provides the final checks and steps to ensure that the unit is fully functional after a calibration has been performed using the Service Card.

1. Ensure all input power to the AT555 is disconnected and then perform the steps in the Assembly section of this manual.

CAUTION: USE ONLY A 13717 CALIBRATED RUBBER EYE FIXTURE THAT HAS BEEN VERIFIED FOR ACCURACY AT THE REICHERT FACTORY WITHIN THE LAST 6 MONTHS OR INCORRECT CALIBRATION MAY RESULT.

2. Align the low value calibrated rubber eye in front of the air-puff nozzle approximately 0.5 to 1.0 inches (1.3 to 2.5 cm) from the end of the nozzle.
Refer to Figure CT-7.
3. Apply the correct input power to the unit and then press any button when displayed.
4. Slide the Left/Right Headrest Assembly fully to the left or right. Press the MEASURE button and take three readings for the low eye.
5. Slide the Left/Right Headrest Assembly fully to the other side. Press the measure button and take three readings for the low eye.
6. Press the button below the PRINT icon.
7. Repeat the three previous steps for both the medium and high rubber eyes.
8. Compare the results to the calibration sheet that you received with your rubber eyes and ensure that the readings are within specifications. If the readings are not within specifications, repeat the tests in this section to correctly calibrate this unit.
9. Move the calibrated rubber eye away from the air-puff nozzle. Place your finger approximately 0.5 inch (1.3 cm) in front of the air-puff nozzle and press the measure button. The tonometer should move toward your finger without touching it and then display "Too Close."

Note: If the tonometer touches your finger with it held still, the proximity sensor may not be working correctly. If the proximity sensor is not working correctly, please call Reichert at the number given in the Introduction section of this procedure.

10. Place your finger onto the metal surface of the grey plate that surrounds the Nosepiece Cover and press the MEASURE button. The LCD must display "Touch Sensor Activated."

Note: If the tonometer moves forward when the metal surface of the touch sensor is touched, then it is not working correctly. If the touch sensor is not working correctly, please call Reichert at the number given in the Introduction section of this procedure.

11. Press the red reset button located behind the printer door and ensure that the unit restarts correctly. Press any key to continue (Models 13910 and 13911 only).

Note: If any of these final checks are not within the limits of what is expected or performing as expected, you may call Reichert, Inc. at the number indicated in the Introduction section of this manual and arrange to return the instrument for service.

12. Press the button below the MODE icon and then press the button below the LOCK icon. This will move the tonometer head into position so that the travel lock can be secured.
13. Secure the travel lock by inserting a Phillips #2 screwdriver into the travel lock slot (behind the printer door) and push it forward so that it mates with the screw and then turn the screw clockwise until it is hand tight (approximately 4 full turns).

Note: A description with pictures of engaging the travel lock is provided in the User's Guide for your reference.

14. This completes the final checks for the unit. The unit should be ready for packaging and/or transportation.

CLEANING

Introduction

This section contains the cleaning procedures. Names given to parts are the same parts as referenced in the AT555 Parts Manual (P/N 13910-102).

Special Tools & Equipment

None Required

Warnings & Cautions

CAUTION: DO NOT USE SOLVENTS OR STRONG CLEANING SOLUTIONS ON ANY PART OF THIS INSTRUMENT OR DAMAGE MAY OCCUR.

CAUTION: USE OF ALCOHOL ON THE LIQUID CRYSTAL DISPLAY (LCD) MAY CAUSE DAMAGE TO THE DISPLAY.

Alignment Window Cleaning Procedure

Refer to Disassembly and perform all the steps indicated before perform the following procedure.

CAUTION: DO NOT USE ALCOHOL, SOLVENTS OR STRONG CLEANING SOLUTIONS ON THE ALIGNMENT WINDOWS OR DAMAGE TO THE WINDOWS WILL OCCUR.

1. Refer to Figure CL-1 and locate the Rear Mask Windows and wipe the outside surfaces with a clean, long handle cotton-tip swab moistened with a mild detergent solution (1 cc of liquid dish soap to one liter of clean, filtered water (filtered below 5 microns)) to remove dirt and contaminants.
2. Remove any remaining dust or foreign particles using only clean, dry, compressed air at less than 90 psig (620 kPa) on both sides of the Rear Mask.

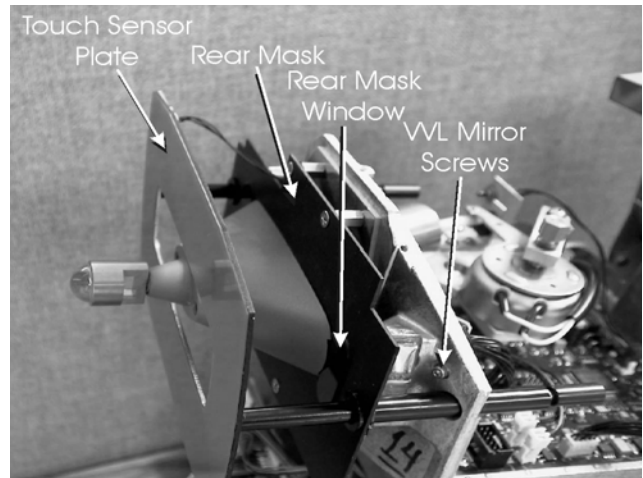

Figure CL-1. Rear Mask Windows

Air Tube Cleaning

WARNING: AFTER CLEANING THE INSIDE OF THE AIRTUBE, PRESS THE BUTTON BELOW THE DEMO ICON LOCATED ON THE OPERATOR'S SCREEN SO THAT ANY CONTAMINANTS ARE SAFELY DISLODGED FROM INSIDE THE AIRTUBE.

1. Install a soft, clean, pipe cleaner down the airtube to a depth of approximately 1.5 in. (or 4 mm.). Move the pipe cleaner in and out of the airtube approximately 10 times to loosen any contaminants. Remove and discard the pipe cleaner.
2. Access the Main menu and press the button below the DEMO icon 5 or 6 times to dislodge any contaminants which were loosened by the pipe cleaner.

External Cleaning Procedure

Clean the external surfaces of this instrument using a clean, soft cloth moistened with a mild detergent solution (1 cc of liquid dish soap to one liter of clean, filtered water (filtered below 5 microns)). DO NOT USE ALCOHOL.

GENERAL DISASSEMBLY

General disassembly of the unit requires removing the outside covers and the top of the tonometer head assembly. Perform the following steps in the order given.

1. Slide the Left/Right Headrest Assembly to one side and remove the screw. Slide the headrest fully to the other side and remove the other screw that secures the headrest assembly. Refer to Figure DS-1.

CAUTION: DO NOT PULL THE HEADREST ASSEMBLY AWAY FROM THE UNIT WITHOUT DISCONNECTING THE LEFT/RIGHT DETECTOR HARNESS OR DAMAGE TO THE UNIT MAY OCCUR CAUSING THE LEFT/RIGHT DETECTOR TO STOP OPERATING.

2. Disconnect the Left/Right Harness from the Headrest Assembly. Refer to Figure DS-2.
3. Insert a Phillips #2 screwdriver into the access holes and turn the screws counterclockwise approximately 6 full turns. The screws only loosen and are retained inside the unit.
4. Remove the Top Cover and carefully push the Left/Right Detector Harness through the access hole. Refer to Figure DS-3.
5. Remove the two screws at the bottom of each side cover. Refer to Figure DS-4.

CAUTION: DO NOT PULL THE SIDE COVER AWAY FROM THE UNIT WITHOUT DISCONNECTING THE LEFT/RIGHT DETECTOR HARNESS FROM THE HARNESS CLIP OR DAMAGE TO THE UNIT MAY OCCUR CAUSING THE LEFT/RIGHT DETECTOR TO STOP OPERATING.

6. Remove the two upper screws on the operator side and one screw on the patient's side that secures the side covers. Remove the side covers, disconnect the Left/Right Harness and place them in a safe location for storage. Refer to Figure DS-5.



Figure DS-1. Left/Right Headrest Removal

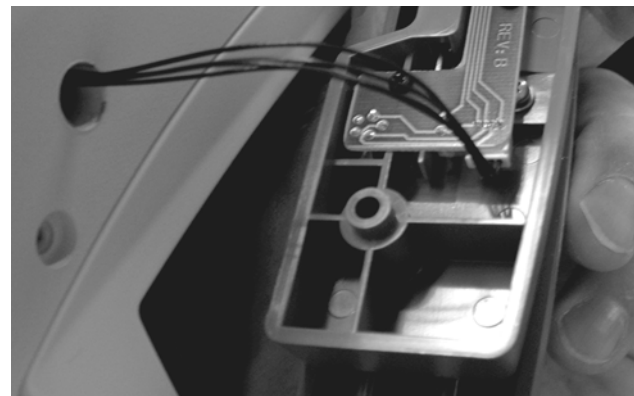

Figure DS-2. Disconnect Left/Right Harness



Figure DS-3. Top Cover Screws Removal

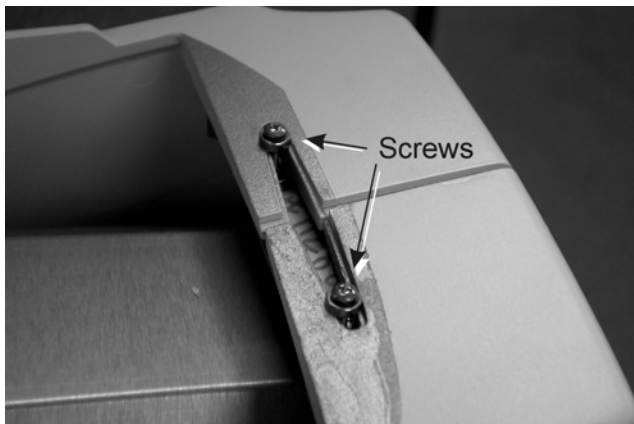

Figure DS-5. Upper Side Cover Screws

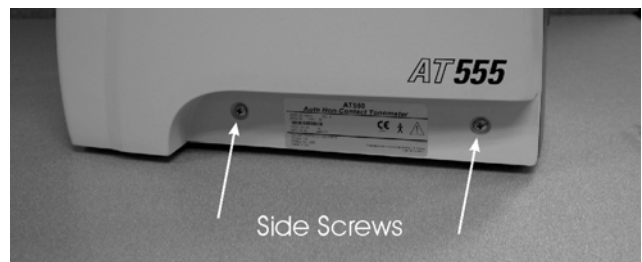

Figure DS-4. Lower Side Cover Screws

REPAIRS

Introduction

This section contains the repair procedures.

Names given to parts are the same parts as referenced in the AT555 Parts Manual (P/N 13910-102).

Perform all steps in Disassembly before performing any of the following repair procedures unless otherwise instructed.

After the necessary repairs are completed, perform all steps in the Assembly section of this manual unless otherwise instructed.

Special Tools & Equipment

None Required

Warnings & Cautions

CAUTION: THE INTERNAL CIRCUITS OF THIS INSTRUMENT HAVE ELECTROSTATIC DISCHARGE SENSITIVE DEVICES (ESDS) AND ARE SENSITIVE TO STATIC HIGH VOLTAGES STORED IN AND TRANSFERRED BY THE HUMAN BODY. OBSERVE CORRECT ESDS PRECAUTIONS OR PREMATURE MALFUNCTION OF THIS INSTRUMENT WILL OCCUR.

CAUTION: ANY REPAIR OR SERVICE TO THE THIS UNIT MUST BE PERFORMED BY DEALERS WHO ARE TRAINED BY REICHERT, INC. SO THAT CORRECT MEASUREMENT OF THIS UNIT IS MAINTAINED.

CAUTION: THE POWER CABLE TO THE LCD DISPLAY CONTAINS VERY HIGH VOLTAGE. DISCONNECT THE INPUT POWER TO THE INSTRUMENT BEFORE DISASSEMBLY OF THE UNIT OR SERIOUS PHYSICAL INJURY MAY OCCUR IF THE HIGH VOLTAGE CONNECTIONS ARE TOUCHED WHILE THE UNIT IS OPERATING.

CAUTION: DO NOT USE SOLVENTS OR STRONG CLEANING SOLUTIONS ON ANY PART OF THIS INSTRUMENT OR DAMAGE MAY OCCUR.

List of Repairs

Repair 1	Nosepiece Cover Replacement
Repair 2	Printer Door Latch Replacement
Repair 3	Printer Replacement
Repair 4	Power I/O Circuit Board Replacement (For 13910 and 13911 Models Only)
Repair 4A	Power I/O Circuit Board Replacement (For 13912 Model Only)
Repair 5	Control Circuit Board Replacement (For 13910 and 13911 Models Only) (No Control Board in Model 13912)
Repair 6	Motor Circuit Board Replacement
Repair 7	LCD Screen Replacement

REPAIR 1

Nosepiece Cover Replacement

The steps below provide the information for changing the Nosepiece Cover.

1. Disengage the connection to the Touch Plate and then remove the Touch Plate from the unit for Models 13910 and 13911 only. The Touch Plate is not removable on the 13912 Model.

Note: Do not lose the insulation bushings that are installed between the Touch Plate and the Spring Tubes.

2. Press the top and bottom of the Nosepiece Cover together until the locking tabs release from the Rear Mask. Refer to Figure R1-1 for an illustration of the location of the Rear Mask.

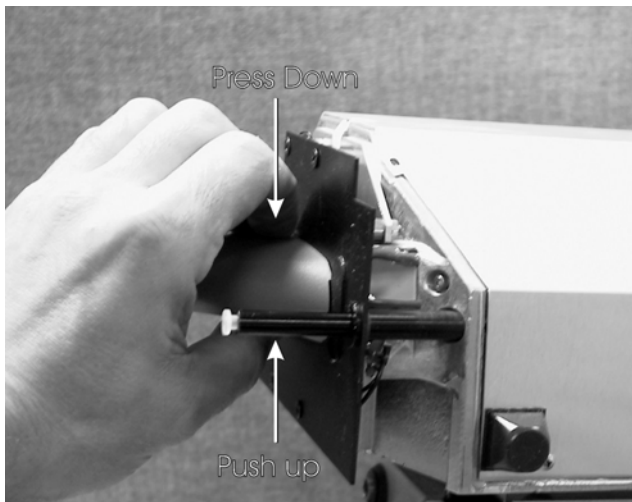

Figure R1-1. Nosepiece Cover Removal

3. Install the new Nosepiece Cover onto the Rear Mask from which the old one was removed.

Note: Make sure that the Nosepiece Cover is installed flat against the Rear Mask or it may apply side pressure to the tip of the airtube causing misalignment of the air delivery system that will effect the readings by displaying asterisk readings or no explanation on the LCD.

REPAIR 2

Printer Door Latch Replacement

This section details the steps necessary to replace a broken printer door latch.

Note: For this repair it is not necessary to perform the steps in Disassembly or Assembly.

1. Open the Printer Door and pull the Latch Finger Assembly completely out of the Latch (Fig.3,11) using a pair of pliers. Refer to Figure R3-1.
2. Put a cut in the middle of the top and bottom sides of the exposed part of the empty latch. Refer to Figure R3-2.
3. Using a needle nose plier, hold one side of the exposed part of the Latch and push it toward the center and at the same time pull it out so that it releases on one side.
4. Repeat the above step for the other side of the empty Latch. When the side releases, the latch should pull completely out of the unit.
5. Install a new Latch by carefully pushing it into the hole.



Figure R2-1, Latch Fingers

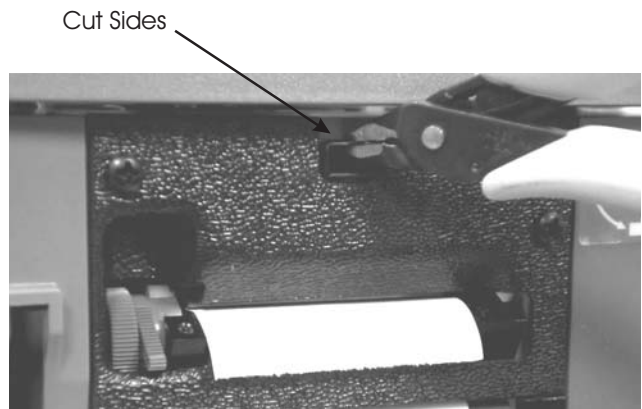

Figure R2-2, Latch Removal

REPAIR 3

Printer Removal

This section details the steps necessary to replace a defective printer. It is not necessary to perform the steps in the Disassembly section of this manual to perform this repair sequence.

CAUTION: THE INTERNAL CIRCUITS OF THIS INSTRUMENT HAVE ELECTROSTATIC DISCHARGE SENSITIVE DEVICES (ESDS) AND ARE SENSITIVE TO STATIC HIGH VOLTAGES STORED IN AND TRANSFERRED BY THE HUMAN BODY. OBSERVE CORRECT ESDS PRECAUTIONS OR PREMATURE MALFUNCTION OF THIS INSTRUMENT WILL OCCUR.

1. Open the Printer Door and remove the Printer Cover Screws that secure the Printer Cover to the Printer Assembly.
2. Remove the four screws that secure the Printer Assembly to the Printer Mount.
3. Remove the four screws that secure the Printer Mount to the Bracket Assembly.
4. Detach the two harnesses from the Printer Assembly.
5. Remove the Printer Assembly from the Printer Mount.

Note: It is difficult to remove the Printer Assembly from the Printer Mount. Refer to Figures R3-2 through R3-4 for illustrations of the Printer Assembly removal.

Printer Installation

1. Install the new printer into the Printer Mount in the reverse order that it was removed.
2. Attach the two printer harnesses to the printer.

CAUTION: DO NOT OVER TIGHTEN THE SCREWS TO THE PRINTER MOUNT AS VERY LITTLE TORQUE IS REQUIRED (4.0 - 6.0 IN -LBS).

3. Secure the Printer Assembly to the Printer Mount using the four screws.
4. Set the Printer Mount against the Bracket Assembly and align the PC Card Slot into the groove at the rear of the Printer Mount. Secure the Printer Mount to the Bracket Assembly using the four screws.

CAUTION: DO NOT OVER TIGHTEN THE SCREWS THAT SECURE THE PRINTER COVER TO THE PRINTER MOUNT AS VERY LITTLE TORQUE IS REQUIRED (4.0 - 6.0 IN -LBS).

5. Secure the Printer Cover to the Printer Mount using the two screws.
6. Align the paper through the paper slot and close the printer door.

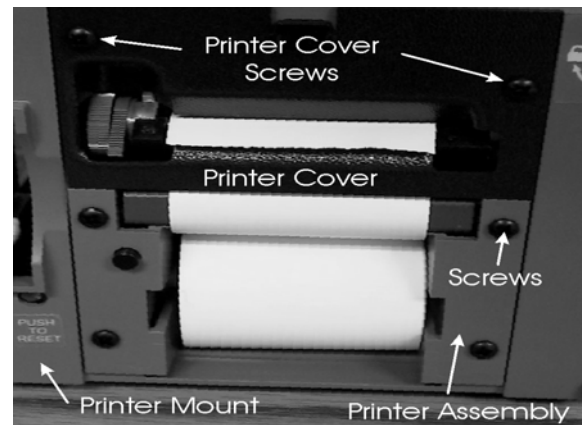

Figure R3-1, Printer Parts ID

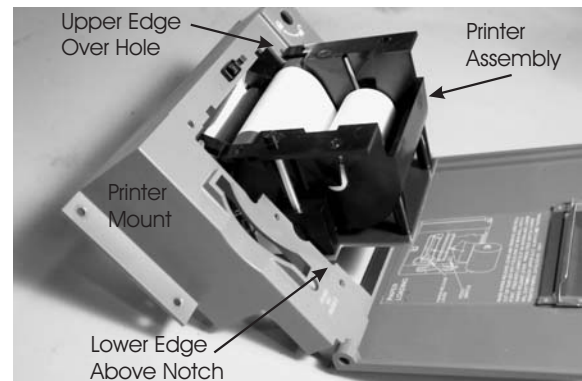

Figure R3-2, Printer Removal Step 1

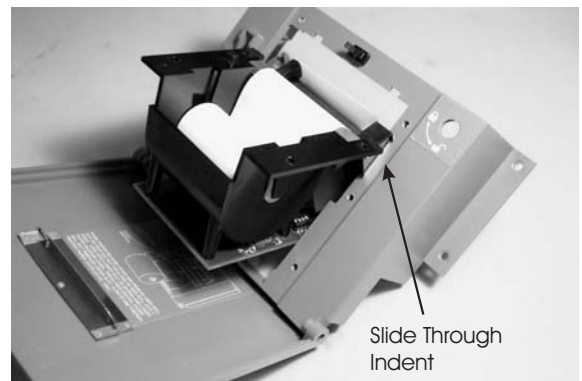

Figure R3-3, Printer Removal Step 2

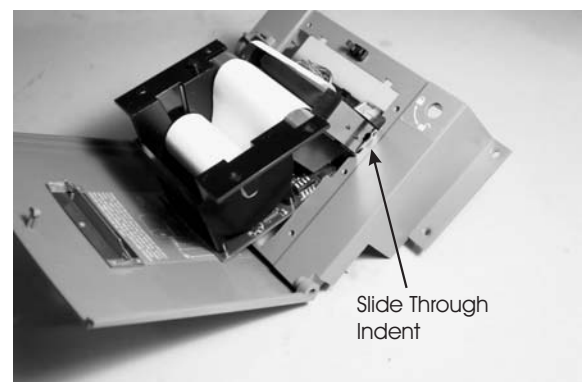

Figure R3-4, Printer Removal Step 3

REPAIR 4

Power I/O Circuit Board Replacement (For 13910 and 13911 Models Only)

This section details the steps necessary to remove/replace the Power I/O Circuit Board.

CAUTION: THE INTERNAL CIRCUITS OF THIS INSTRUMENT HAVE ELECTROSTATIC DISCHARGE SENSITIVE DEVICES (ESDS) AND ARE SENSITIVE TO STATIC HIGH VOLTAGES STORED IN AND TRANSFERRED BY THE HUMAN BODY. OBSERVE CORRECT ESDS PRECAUTIONS OR PREMATURE MALFUNCTION OF THIS INSTRUMENT WILL OCCUR.

Special Tools and Equipment

Dow Corning* RTV 732 Multi Purpose Sealant

PI/O Board Removal

Refer to Figure R4-1 for the layout of the circuit board.

1. Disconnect the earth ground connection from under the Tonometer Head.
2. Disconnect the power connector (J13) at the Power I/O Circuit Board (also referred to as PIOB) that connects to the Tonometer Head.
3. Disconnect the data harnesses (J11) and the power harness (J6) on the PIOB that connects to the Motor Board.

CAUTION: DO NOT TO CUT INTO THE WIRES THAT SECURE THE WIRES TO THE XYZ POSITIONING SYSTEM.

4. Cut the plastic wire tie that secures the transformer and ground wires to the XYZ Positioning Assembly.
5. Remove the four screws, washers, and nuts that secure the XYZ Positioning Assembly to the Mounting Base. Separate the XYZ Positioning Assembly (and Tonometer Head assembly) from the Base Casting. Set the XYZ Positioning Assembly on its side next to the Base Casting.
6. Disconnect the power connector (J3) and the data harness (J8) at the PIOB that connects to the LCD screen.
7. Disconnect the power connector (J10) and the data harness (J12) at the PIOB that connects to the Printer Assembly.
8. Disconnect the power connector (J5) at the PIOB that connects to the Transformer.
9. Disconnect the data harness (J7) at the PIOB that connects to the Keypad Assembly.
10. Remove the two standoffs, and lock washers that secure the 9-pin computer interface connector to the Power Identification Panel.
11. Remove the three screws that secure the PIOB to the Base Casting.
12. Remove the Power I/O Board from the Base Casting.

- Continued -

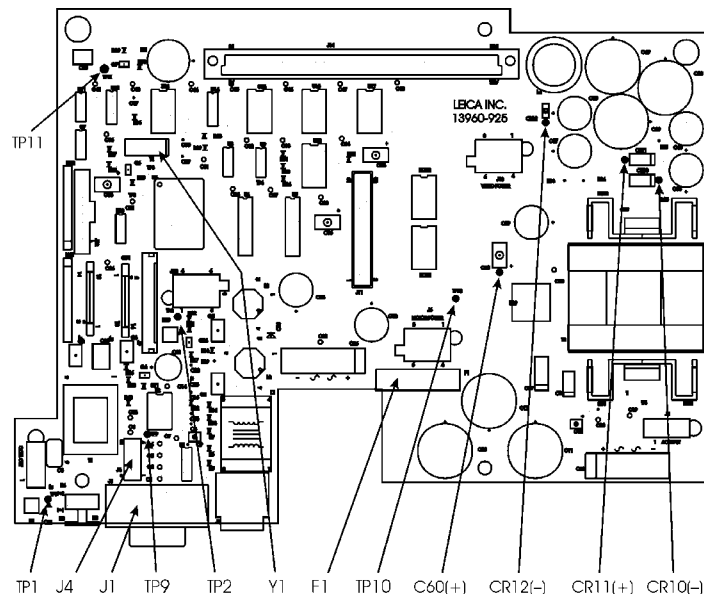

Figure R4-1, Connector Locations (Models 13910 & 13911 Only)

* Dow Corning is a registered trademark of Dow Corning

REPAIR 4 (CONTINUED)

PI/O Board Installation

CAUTION: THE INTERNAL CIRCUITS OF THIS INSTRUMENT HAVE ELECTROSTATIC DISCHARGE SENSITIVE DEVICES (ESDS) AND ARE SENSITIVE TO STATIC HIGH VOLTAGES STORED IN AND TRANSFERRED BY THE HUMAN BODY. OBSERVE CORRECT ESDS PRECAUTIONS OR PREMATURE MALFUNCTION OF THIS INSTRUMENT WILL OCCUR.

1. Remove the new Power I/O Board (PIOB) from its antistatic bag using ESD precautions and then set the PIOB in place onto the Base Casting and align the PIOB over the three plastic standoffs. Secure the PIOB onto the plastic standoffs. Place the damaged PIOB into the antistatic bag.
2. Secure the PIOB with the three screws and washers.
3. Install the two standoffs and that secure the computer interface connector to the Base Casting.
4. Install the data harnesses (J7, & J8) from the Keypad Assembly and LCD to the PIOB. Ensure that the locking bars of the connectors are engaged. Apply a thin bead of RTV 732 or equivalent across the top of each of the connectors to aid in securing the cables to the connector.
5. Attach the power connector (J5) from the Transformer to the PIOB.
6. Attach the data connector (J12) and the power connector (J10) from the Printer Assembly to the PIOB.
7. Attach the LCD power connector (J3) to the PIOB.
8. Place the XYZ Positioning Assembly over the Base Casting and install the four screws, washers, and nuts that secure it to the Base Casting.

Note: Ensure that the Control Board (side circuit board attached to the XYZ Positioning Assembly) is correctly placed into its slot on the Printer Mount so that when a PCMIA card is installed into the slot it does not bind.

9. Attach the data harness (J11) and the power connector (J6) from the Motor Board to the PIOB.
10. Attach tonometer power connector (J13) to the PIOB.
11. Attach the earth ground harness from the Base Casting to the terminal lug on the bottom of the Tonometer Head near the LCD.
12. Secure the earth ground wires and the transformer input power harness to the tie wrap mount on the side of the XYZ support bracket using a plastic tie wrap.
13. Perform the steps in the [LCD Adjustment](#) section of this manual so that the correct voltages are set on the PIOB for the LCD assembly.
14. Perform the steps in the [Assembly](#) section of this manual.

REPAIR 4A

Power I/O Circuit Board Replacement (For 13912 Model Only)

This section details the steps necessary to remove/replace the Power I/O Circuit Board.

CAUTION: THE INTERNAL CIRCUITS OF THIS INSTRUMENT HAVE ELECTROSTATIC DISCHARGE SENSITIVE DEVICES (ESDS) AND ARE SENSITIVE TO STATIC HIGH VOLTAGES STORED IN AND TRANSFERRED BY THE HUMAN BODY. OBSERVE CORRECT ESDS PRECAUTIONS OR PREMATURE MALFUNCTION OF THIS INSTRUMENT WILL OCCUR.

Special Tools and Equipment

Dow Corning* RTV 732 Multi Purpose Sealant

PI/O Board Removal

Refer to Figure R4-2 for the layout of the circuit board.

1. Disconnect the earth ground connection from under the Tonometer Head.
2. Disconnect the power connector (J1) and the data harnesses (J2) at the Power I/O Circuit Board (also referred to as PIOB) that connects to the Tonometer Head.
3. Disconnect the power harness (J12) and the data harness (J5) on the PIOB that connects to the Motor Board.

CAUTION: DO NOT TO CUT INTO THE WIRES THAT SECURE THE WIRES TO THE XYZ POSITIONING SYSTEM.

4. Cut the plastic wire tie that secures the wires to the XYZ Positioning Assembly.
5. Remove the four screws, washers, and nuts that secure the XYZ Positioning Assembly to the Mounting Base. Separate the XYZ Positioning Assembly (and Tonometer Head assembly) from the Base Casting. Set the XYZ Positioning Assembly on its side next to the Base Casting.
6. Disconnect the power connector (J11) and the data harness (J7) at the PIOB that connects to the LCD screen.
7. Disconnect the power connector (J3) and the data harness (J4) at the PIOB that connects to the Printer Assembly.
8. Disconnect the power connector (J10) at the PIOB that connects to the Power Supply.
9. Disconnect the data harness (J7) at the PIOB that connects to the Keypad Assembly.
10. Remove the two standoffs, and lock washers that secure the 9-pin computer interface connector to the Power Identification Panel.
11. Remove the four screws that secure the PIOB to the Base Casting.

- Continued -

REPAIR 4A (CONTINUED)

PI/O Board Installation

CAUTION: THE INTERNAL CIRCUITS OF THIS INSTRUMENT HAVE ELECTROSTATIC DISCHARGE SENSITIVE DEVICES (ESDS) AND ARE SENSITIVE TO STATIC HIGH VOLTAGES STORED IN AND TRANSFERRED BY THE HUMAN BODY. OBSERVE CORRECT ESDS PRECAUTIONS OR PREMATURE MALFUNCTION OF THIS INSTRUMENT WILL OCCUR.

1. Remove the new Power I/O Board (PIOB) from its antistatic bag using ESD precautions and then set the PIOB in place onto the Base Casting and secure the PIOB with the four screws and washers.
2. Install the two standoffs and that secure the Computer Interface connector to the Base Casting.
3. Install the data harnesses (J6, & J7) from the Keypad Assembly and LCD to the PIOB. Ensure that the locking bars of the connectors are engaged. Apply a thin bead of RTV 732 or equivalent across the top of each of the connectors to aid in securing the cables to the connector.
4. Attach the power connector (J10) from the Power Supply to the PIOB.
5. Attach the data connector (J4) and the power connector (J3) from the Printer Assembly to the PIOB.
6. Attach the LCD power connector (J11) to the PIOB.
7. Place the XYZ Positioning Assembly over the Base Casting and install the four screws, washers, and nuts that secure it to the Base Casting.
8. Attach the data harness (J5) and the power connector (J12) from the Motor Board to the PIOB.
9. Attach data harness (J5) and the power connector (J1) from the optical head to the PIOB.
10. Attach the earth ground harness from the Base Casting to the terminal lug on the bottom of the Tonometer Head near the LCD.
11. Secure the wires to the tie wrap mount on the side of the XYZ support bracket using a plastic tie wrap.
12. Perform the steps in the Assembly section of this manual.

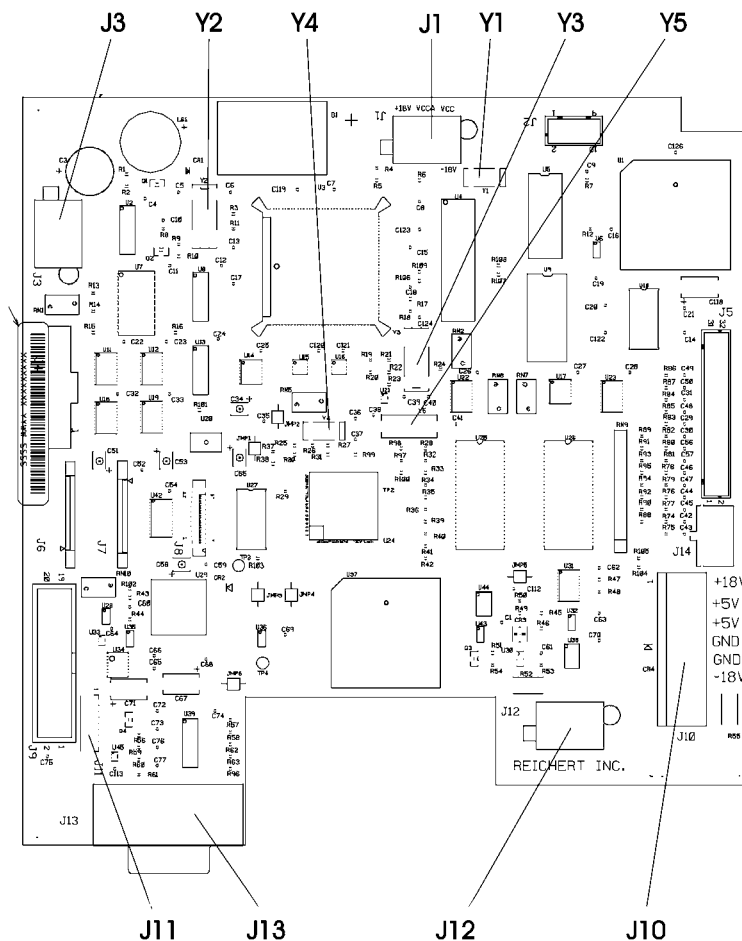

Figure R4-2, Connector Locations (Model 13912 Only)

REPAIR 5

Control Circuit Board Replacement (For 13910 and 13911 Models Only) (No Control Board in Model 13912)

This section details the steps necessary to remove/replace the Control Circuit Board.

Note: Refer to Figure TT-5 for an illustration of the Control Circuit Board.

CAUTION: THE INTERNAL CIRCUITS OF THIS INSTRUMENT HAVE ELECTROSTATIC DISCHARGE SENSITIVE DEVICES (ESDS) AND ARE SENSITIVE TO STATIC HIGH VOLTAGES STORED IN AND TRANSFERRED BY THE HUMAN BODY. OBSERVE CORRECT ESDS PRECAUTIONS OR PREMATURE MALFUNCTION OF THIS INSTRUMENT WILL OCCUR.

Control Board Removal

1. Remove the plastic tie wrap that secures the wires to the J2 connector and remove the J2 harness from the connector.
2. Remove the two screws that attach the Control Circuit Board (CCB) to the XYZ Positioning Assembly.
3. Remove the two screws that secure the Printer Mount on the CCB side of the unit. Loosen the other two screws so that the Printer Mount can move forward on the CCB side of the unit.
4. Remove the CCB from the unit.
5. Remove the standoffs from the top side of the CCB.
6. Observing ESD precautions, remove the new CCB from its antistatic bag and install the standoffs onto the new CCB. If the new CCB does not have a chip in the U18 socket, remove it from the damaged CCB and install it onto the new CCB.

Control Board Installation

1. Place the new CCB onto the Power I/O Board and align; the reset button into its hole, and the top of the CCB into its slot on the back side of the Printer Mount. Carefully press the CCB into its mating connector on the Power I/O Board.

Note: Before installing the screws that secure the CCB, install a PCMIA card into the slot to ensure that it does not bind. Remove it when aligned.

2. Install the two screws that secure the CCB to the XYZ support bracket.
3. Attach the data harness (J2) to the CCB.
4. Secure the J2 data harness to the tie wrap mount on the CCB using a plastic tie wrap.
5. Perform the steps in the Assembly section of this manual.

REPAIR 6

Motor Circuit Board Replacement

This section details the steps necessary to remove/replace the Motor Board.

Note: Refer to Figure TT-7 for an illustration of the Motor Circuit Board.

CAUTION: THE INTERNAL CIRCUITS OF THIS INSTRUMENT HAVE ELECTROSTATIC DISCHARGE SENSITIVE DEVICES (ESDS) AND ARE SENSITIVE TO STATIC HIGH VOLTAGES STORED IN AND TRANSFERRED BY THE HUMAN BODY. OBSERVE CORRECT ESDS PRECAUTIONS OR PREMATURE MALFUNCTION OF THIS INSTRUMENT WILL OCCUR.

Motor Board Removal

1. Install identification tags to the connectors that attach to the Motor Circuit Board (also referred to as MCB) as the connectors across the top of the MCB have the same colors and will physically interchange, but will show error codes if power is applied to the unit and the connectors are not correctly attached.
2. Remove the four screws, that attach the MCB to the XYZ support bracket.
3. Remove the plastic tie-wrap that secures the wires from the XYZ Assembly to the J4 connector on the MCB.
4. Observe ESD precautions and remove the new MCB from its antistatic bag. Disconnect one connector from the damaged MCB and install it onto the new MCB. Repeat this step until all connectors are installed onto the new MCB.
5. If the new MCB does not have a chips in its XU5, XU6, and XU7 sockets, remove them from the damaged MCB and install them onto the new MCB. Place the damaged MCB into the antistatic bag.

Motor Board Installation

1. Secure the new MCB onto the XYZ support bracket using the four screws that were removed.
2. Ensure that potentiometer, R15, is set fully clockwise (10:00, 4:00 position) on the MCB.
3. Attach a plastic tie-wrap to secure the sensor wires of the XYZ Assembly to the J4 connector on the MCB.
4. Perform the steps in the Assembly section of this manual.

REPAIR 7

LCD Screen Replacement

Introduction

This instruction sheet provides instructions regarding installation of a replacement LCD Screen (13960-966 or 13900-403).

Note: Refer to Figure TT-3 or TT3A for an illustration of the test points on the Power I/O Board. Refer to Figures TT-1 and TT-2 for illustrations of the LCD screens.

Special Tools & Equipment

Digital Voltmeter (-50 to +50 VDC)

LCD Removal

Disconnect all input power from the unit. Remove the top and side covers of the unit as indicated in the Service Manual.

CAUTION: THE POWER CABLE TO THE LCD DISPLAY CONTAINS VERY HIGH VOLTAGE. DISCONNECT THE INPUT POWER TO THE INSTRUMENT BEFORE DISASSEMBLY OF THE UNIT OR SERIOUS PHYSICAL INJURY MAY OCCUR IF THE HIGH VOLTAGE CONNECTIONS ARE TOUCHED WHILE THE UNIT IS OPERATING.

CAUTION: THE INTERNAL CIRCUITS OF THIS INSTRUMENT HAVE ELECTROSTATIC DISCHARGE SENSITIVE DEVICES (ESDS) AND ARE SENSITIVE TO STATIC HIGH VOLTAGES STORED IN AND TRANSFERRED BY THE HUMAN BODY. OBSERVE CORRECT ESDS PRECAUTIONS OR PREMATURE MALFUNCTION OF THIS INSTRUMENT WILL OCCUR.

Note: Ensure all input power to the unit is disconnected before removal of the LCD.

1. Remove the four screws that attach the front bezel with the Reichert logo. Remove the bezel.
2. Remove the four screws that secure the LCD to its mounting bracket.
3. Models 13910 and 13911 only:
Disconnect the LCD data connector that attaches onto the back side of the LCD at connector CN1.

Model 13912 Only:

Disconnect the LCD data connector that attaches to the connector on the CCFL Inverter Module.

4. Disconnect the high voltage LCD backlight connector that attaches to the bottom circuit board at J3.

LCD Installation

1. Attach the data cable to the back of the LCD at CN1. Ensure that the cable is secure and oriented straight into CN1.
2. Install the new LCD screen using the four screws that were removed. Use one drop of threadlocker (e.g. Loctite 222*) on the threads to secure the screws.

Note: If replacing the LCD with P/N 13900-403 and the upper right screw has an isolation washer installed between the screw and the circuitboard, ensure that the isolation washer is installed in the same location during assembly of the replacement LCD. Refer to the Testing section of this manual for an illustration of the 13900-403 LCD.

3. Models 13910 and 13911 only:
Attach the High Voltage LCD backlight connector to the J3 connector on the bottom circuit board. Ensure that the cable is routed through the tie wrap located around the front support and that the connector is locked into position.

Model 13912 Only:

Attach the High Voltage LCD backlight connector to the connector on the CCFL Inverter Module.

4. Install the front bezel using the four screws that were removed. Use one drop of threadlocker (e.g. Loctite 222) on the threads to secure the screws.

Note: Do not install the outside covers at this time.

5. Models 13910 and 13911 only:
Refer to the Testing section of this manual and perform the steps in the LCD Brightness Adjustment paragraph.
6. Models 13910 and 13911 only:
Refer to the Testing section of this manual and perform the steps in the LCD Contrast Adjustment paragraph.
7. Perform the Steps in the Assembly section of this manual.

* Loctite is a Trade Name of Loctite CORP., U.S.A.

GENERAL ASSEMBLY

General assembly of the unit requires assembling the outside covers and top of unit. Perform the following steps in the order given.

1. Ensure that the harness to the Left/Right Headrest Assembly (also referred to as LRHA) is connected to the motor board at J13.
2. Install one of the side covers and secure it with the bottom side screws. Install the other side cover and secure it with the bottom side screws. Refer to Figure AS-1.
3. Install the upper side cover screws on the operator's side of the unit and secure both side covers. Refer to Figure AS-2.
4. Tighten the top screws on the patient's end to secure the bracket to the side covers.
5. Slide the harness into its retaining clip located on the side cover. Refer to Figure AS-3.

CAUTION: DURING ASSEMBLY, ENSURE THAT THE LEFT/RIGHT DETECTOR HARNESS IS INSTALLED INTO THE HARNESS CLIP OR THE WIRES MAY BECOME DAMAGED DUE TO IMPROPER PLACEMENT.

6. Place the connector at the end of the harness through the top, left hole in the front of the Top Cover. (Refer to Figure AS-5).
7. Install the Top Cover onto the instrument so that the lower front edge of the Top Cover is even with the lower edge of the opening on the patient's end of the side covers. Refer to Figure AS-4.
8. Insert a Phillips #2 screwdriver into the access holes and turn the screws clockwise until they are secure at 10.0 lbf•in (1.1 N•m). Refer to Figure AS-5.
9. Attach the harness to the circuit board on the back side of the LRHA.
10. Place the LRHA into its mounting holes in the front of the Top Cover and secure the screws clockwise to 10.0 lbf•in (1.1 N•m). Refer to Figure AS-6.
11. Take a measurement of a patient to ensure that the unit is correctly working. If the unit does not take a measurement, go to the [Troubleshooting](#) section of this manual and determine the cause of the malfunction.

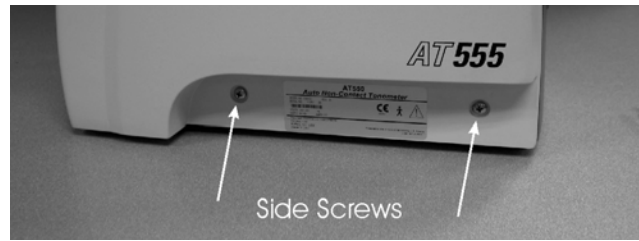

Figure AS-1. Lower Side Cover Screws

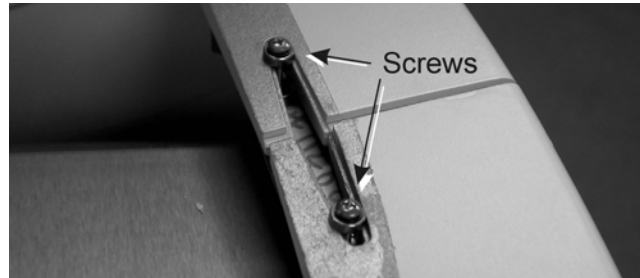

Figure AS-2. Upper Side Cover Screws



Figure AS-3. Wire Harness Retaining Clip



Figure AS-4. Top Cover Alignment



Figure AS-5. Top Cover Screws Installation



Figure AS-6. Headrest Installation

APPENDIX A - GENERAL SPECIFICATIONS

Specifications:

Height:	17 in., 43.0 cm.
Width:	9 1/2 in., 24.0 cm.
Depth:	13 1/2 in., 34.0 cm.
Weight, unpacked:	30 lbs., 13.6 kg.
Voltage:	Catalog No. 13910 100V to 120V Catalog No. 13911 220V to 240V Catalog No. 13912 100V to 240V
Current:	Model 13910 - 1.0 amp Model 13911 - 0.5 amp Model 13912 - 1.0 amp
Frequency:	50/60 Hz
Measurement Range:	0 - 60 mmHg

Transportation & Storage

This instrument can withstand the following conditions while packed for transportation or storage:

- an ambient temperature range of -40°C to + 70°C
- a relative humidity range of 10% to 90%
- an atmospheric pressure range of 500 kPa to 1060 kPa.

Exposure to these extreme conditions indicated above should not exceed 15 weeks.

Disposal

This product does not generate any environmentally hazardous residues. At end of product life, follow local laws and ordinances regarding proper disposal of equipment.

This product does not generate any environmentally hazardous residues. At end of product life, follow local laws and ordinances regarding proper disposal of equipment.

APPENDIX B - HARNESS CONNECTION LIST

FROM	TO	DESCRIPTION	PART NUMBER
13900-945, MOTOR CONTROL PCB (all)			
13900-945, J2	13960-938	HOME SWITCH ASSY HARNESS	13960-938 ASSY
13900-945, J8, J10, J12	13920-948, MOTOR X MOTOR Y MOTOR Z	MOTOR ASSY HARNESS	13920-948 ASSY
13900-945, J13	13900-924, J1	HEADREST ASSY HARNESS (P/N 13900)	13900-939 & 13900-944
13900-945, J13	13950-924, J1	HEADREST ASSY HARNESS (P/N 13910, 13912)	13910-931
13960-925, POWER I/O PCB (P/N 13900/13901)			
13960-925, J3	13960-966 ASSY	LCD DISPLAY ASSY	13960-966
13960-925, J6	13900-945, J4	MOTOR POWER HARNESS	13960-939
13960-925, J7	13920-924, J1	KEYPAD HARNESS	13920-939
13960-925, J8	13960-966 ASSY	FLAT FILM CABLE	13920-939
13960-925, J10	13963-921, J1	PRINTER POWER HARNESS	13930-932
13960-925, J11	13900-945, J1	MOTOR DATA HARNESS	13960-940
13960-925, J12	13963-921, J2	PRINTER DATA HARNESS	13930-931
13960-925, J13	13900-922, J3	TONOMETER POWER HARNESS	13960-946
13910-922, POWER I/O PCB (P/N 13910/13911)			
13910-922, J3	13960-408 ASSY	LCD DISPLAY ASSY	13900-947
13910-922, J6	13900-945, J4	MOTOR POWER HARNESS	13960-939
13910-922, J7	13920-924, J1	KEYPAD HARNESS	13920-939
13910-922, J8	13960-408 ASSY	FLAT FILM CABLE	13920-939
13910-922, J10	13963-921, J1	PRINTER POWER HARNESS	13930-932
13910-922, J11	13900-945, J1	MOTOR DATA HARNESS	13960-940
13910-922, J12	13963-921, J2	PRINTER DATA HARNESS	13930-931
13910-922, J13	13900-922, J3	TONOMETER POWER HARNESS	13960-946
13912-925, POWER - MAIN PCB (P/N 13912)			
13912-925, J1	13880-922, J3	TONOMETER POWER HARNESS	13880-936
13912-925, J2	13880-922, J1	TONOMETER DATA HARNESS	13880-937
13912-925, J3	13963-921, J1	PRINTER POWER HARNESS	13930-932
13912-925, J4	13963-921, J2	PRINTER DATA HARNESS	13930-931
13912-925, J5	13900-945, J1	MOTRO DATA HARNESS	13960-940
13912-925, J6	13920-924, J1	FLAT FILM CABLE	13920-939
13912-925, J7	13912-401, J1	KEYPAD HARNESS	13920-939
13912-925, J11	13880-403, N1	CCFL INVERTER	13880-935
13912-925, J12	13900-945, J4	MOTOR POWER HARNESS	13960-939
		- Continued -	

APPENDIX B - HARNESS CONNECTION LIST (CONTINUED)

FROM	TO	DESCRIPTION	PART NUMBER
INPUT POWER CONNECTIONS (P/Ns 13910/13911)			
TRANSFORMER	13910-922, J5	TRANSFORMER HARNESS (115V)	13960-942
TRANSFORMER	13910-922, J5	TRANSFORMER HARNESS (230V)	13960-943
PWR. INPUT RECPT.	CHASSIS	GROUND HARNESS	13920-940
OPTICAL HEAD	CHASSIS	GROUND STRAP HARNESS	13960-951
INPUT POWER CONNECTIONS (P/N 13912)			
13880-402 PWR SPLY	13912-925, J10	POWER SUPPLY (13880-402) TO MAIND BOARD	13880-934
POWER INLET	13880-402 PWR SPLY	POWER HARNESS	13880-932
PWR. INPUT RECPT.	CHASSIS	GROUND HARNESS	13880-933
OPTICAL HEAD	CHASSIS	GROUND STRAP HARNESS	13960-951
TONOMETER HEAD ASSEMBLY (P/Ns 13910/13911)			
13900-922, J1	13900-921, J2	TONOMETER DATA HARNESS	13900-935
13900-922, J2	13900-111	SOLENOID ASSEMBLY	13900-858
13880-922, J3	13912-925, J1	TONOMETER POWER HARNESS	13880-936
13900-922, J4, J5	13900-932	CAMERA POSITION HARNESS	13960-947
13900-922, J7, J8	13900-928	POSITION ILLUMINATOR	13900-928
13900-922, J9	13900-925	FIXATION ILLUMINATOR	13900-937
13900-922, J10	13900-926 13900-927 13900-930 13900-931 13900-949	APPLANATION EMITTER APPLANATION DETECTOR TOUCH SENSOR PROXIMITY DETECTOR PATIENT LED'S (13910/13911 ONLY)	13900-938
13900-922, J13	13900-943	Z-TRAVEL SWITCH	13900-943
TONOMETER HEAD ASSEMBLY (P/N 13912)			
13880-922, J1	13912-925, J2	TONOMETER DATA HARNESS	13880-937
13880-922, J2	13900-111	SOLENOID ASSEMBLY	13900-858
13880-922, J4, J5	13880-924	CAMERA POSITION HARNESS	13960-947
13880-922, J7, J8	13900-928	POSITION ILLUMINATOR	13900-928
13880-922, J9	13900-925	FIXATION ILLUMINATOR	13900-937
13880-922, J10	13900-926 13900-927	APPLANATION EMITTER APPLANATION DETECTOR	13880-938
13880-922, J14	13880-048	TOUCH PLATE ASSY	13880-940, 13960-949
13880-922, J15	13880-939	PROXIMITY DETECTOR	13880-939
13880-922, J16	13880-923	PATIENT LED'S	13880-923

APPENDIX C - SOFTWARE REVISION LIST

Model 13910 and 13911

Revision 1.20

- Initial release.

Revision 1.20 to 1.21 (1/03)

- Change Leica name to Reichert name on opening screen.
Reword the Touch Sensor Activated, and Too Close Activated screens for better instruction.

Revision 1.21 to 1.22 (4/03)

- Update Help screens

Revision 1.22 to 1.23 (7/03)

- Added Reichert Registered Trademark to initial screen.
- Correction of spelling errors.

Model 13912

Revision 2.23 (9/04)

- Initial release

Revision 2.23 to 2.30 (4/03)

- Change printer data to match LCD data.

APPENDIX D - RUBBER EYE CLEANING PROCEDURE

Rubber Eye Cleaning Procedure

Caution: *Cleanliness and integrity of the rubber eye surface is required to maintain proper function and longevity of the rubber eye.*

Caution: *Do not abuse the surface of the rubber eye through rough handling or use abrasive materials to clean it. Once the rubber eye is mounted in the fixture, avoid touching or moving the eye.*

Procedure

1. Wash your hands to remove all dirt and oils.
2. When cleaning T-bar mounted rubber eyes, mark the location of the white dot on the rubber eye on the T-bar before removing the rubber eye.
3. Remove the rubber eye from its rubber eye mount (attached to the T-bar) or its storage container by grasping the outer edge and gently pulling up.
4. With your finger, wash the eye with a lanolin-free, mild, liquid soap and distilled water (*tap water may be used, however there is an increased risk of damage to the eye when using tap water.*).
5. Rinse clean the rubber eye with water.
6. Use clean, dry air to remove the water from the rubber eye.
Note: *Do not use a tissue or a cloth to dry the rubber eye.*
7. Replace the rubber eye onto the rubber eye mount located on the T-bar:
 - a. Hold the outer edges of the rubber eye and align the white dots.
 - b. Carefully push the rubber eye onto the rubber eye mount using a rocking motion until it is fully seated and not tilted in any direction.
 - c. Visually inspect the rubber eye so that the white dots align and the rubber eye is seated flat against the rubber eye mount.
8. Maintain calibration every six months to ensure that the value of the rubber eye has not changed and the calibration date has not expired.

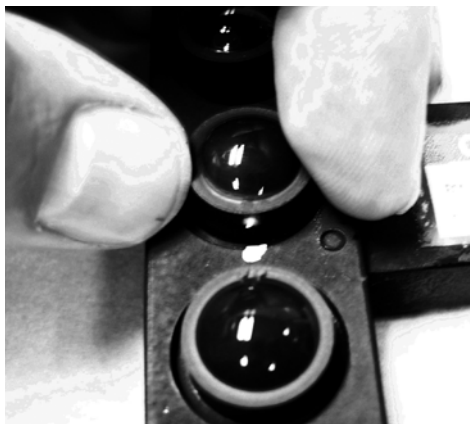

ORDERING INFORMATION - ACCESSORIES

CatalogDescription

12418 Instrument stand adapter mount
12430-273 Cleaning Cloth
12441 Printer paper
13910-101 User's Guide
13916 External power supply universal input, 16 VDC out @ 0.0 to 3.12 amps

Note: This power supply is medically approved to UL2601-1, IEC60601-1 and CSA C22.2 NO. 601.1 standards

13920-084 Dust Cover

- To order any of these accessories, contact your local authorized Reichert dealer.

OTHER REICHERT PRODUCTS

To complement your AT555 Auto Tonometer, we invite you to take a look at the other products made by our company:

AL200 Auto Lensometer

Keratometer

LongLife™ Project-O-Chart

Phoroptor® Refracting Instrument

XCEL® Slit Lamps

AP250 Auto Projector

PT100 Handheld Tonometer

- To order any of these products, contact your local authorized Reichert dealer.

Reichert, Inc.
Ophthalmic Instruments
3374 Walden Ave.
Depew, New York USA 14043
Telephone: 716-686-4500
Fax: 716-686-4545
www.reichert.com
e-mail: info@reichert.com
ISO-9001 Certified

13910-103, Rev. B 8/05

The logo for Reichert Ophthalmic Instruments features the word "Reichert" in a large, bold, sans-serif font. Above the letter "i" in "Reichert" is a stylized graphic of an eye. Below "Reichert" is the phrase "Ophthalmic Instruments" in a smaller, clean sans-serif font.