



INSTRUCTIONS

-J05887

REV. 2014-04-03

FRONT BRAKE CALIPER KITS

GENERAL

Kit Numbers

41300120, 41300126

Models

For model fitment information, see the P&A retail catalog or the Parts and Accessories section of www.harley-davidson.com (English only).

This kit is a direct replacement for the original equipment (OE) components, and installs in the same manner.

Installation Requirements

Fresh, uncontaminated hydraulic brake fluid from a sealed container is needed. Refer to the service manual for this year/model motorcycle to determine the correct brake fluid.

Electrical Contact Lubricant (Part No. 99861-02) or equivalent is required after battery cable disconnection. This item is available from a Harley-Davidson dealer.

WARNING

The rider's safety depends upon the correct installation of this kit. Use the appropriate service manual procedures. If the procedure is not within your capabilities or you do not have the correct tools, have a Harley-Davidson dealer perform the installation. Improper installation of this kit could result in death or serious injury. (00333a)

NOTE

This instruction sheet refers to service manual information. A service manual for this year/model motorcycle is required for this installation. One is available from a Harley-Davidson dealer.

WARNING

Brakes are a critical safety component. Contact a Harley-Davidson dealer for brake repair or replacement. Improperly serviced brakes can adversely affect brake performance, which could result in death or serious injury. (00054a)

Kit Contents

See Figure 1 and Table 1.

PREPARATION

WARNING

To prevent accidental vehicle start-up, which could cause death or serious injury, remove main fuse before proceeding. (00251b)

WARNING

To prevent accidental vehicle start-up, which could cause death or serious injury, disconnect negative (-) battery cable before proceeding. (00048a)

NOTE

- **2007 vehicles WITH security siren:** With security fob present, turn ignition switch ON. See the service manual. After system is disarmed, turn ignition switch OFF. **IMMEDIATELY** remove the main fuse.
- **2006-earlier vehicles WITH security siren:** Disarm the siren with the key fob or security code. See the service manual. Remove the main fuse or negative battery cable.
- **Vehicles WITHOUT security siren:** See the service manual. Remove the main fuse or negative battery cable.

INSTALLATION

Refer to the service manual for this year/model motorcycle to determine the correct brake fluid.

CAUTION

Direct contact of D.O.T. 5 brake fluid with eyes can cause eye irritation, swelling, and redness. Avoid eye contact. In case of eye contact flush with large amounts of water and get medical attention. Swallowing large amounts of D.O.T. 5 brake fluid can cause digestive discomfort. If swallowed, obtain medical attention. Use in well ventilated area. **KEEP OUT OF REACH OF CHILDREN.** (00144a)

CAUTION

Direct contact of D.O.T. 4 brake fluid with eyes can cause irritation. Avoid eye contact. In case of eye contact flush with large amounts of water and get medical attention. Swallowing large amounts of D.O.T. 4 brake fluid can cause digestive discomfort. If swallowed, obtain medical attention. Use in well ventilated area. **KEEP OUT OF REACH OF CHILDREN.** (00240a)

NOTICE

D.O.T. 4 brake fluid will damage painted and body panel surfaces it comes in contact with. Always use caution and protect surfaces from spills whenever brake work is performed. Failure to comply can result in cosmetic damage. (00239b)

NOTE

If DOT 4 brake fluid contacts painted surfaces, IMMEDIATELY flush area with clear water.

Cover nearby motorcycle surfaces to protect against damage to the finish caused by spillage or splash of DOT 4 brake fluid.

⚠ WARNING

Replace brake line gaskets. Re-using original gaskets can cause brake failure and loss of vehicle control, which could result in death or serious injury. (00318a)

NOTICE

Remove brake line components carefully. Damage to seating surfaces can cause leakage. (00320a)

1. See the service manual. Remove the front brake caliper or calipers.
2. Install the **new** front brake caliper or calipers per service manual instructions.

COMPLETION

NOTE

Verify that the ignition key switch is in the OFF position **before** installing the main fuse or negative battery cable.

1. See the service manual. Install the main fuse or negative battery cable.

Apply a light coat of petroleum jelly or corrosion retardant material to battery terminals if cable was removed.

⚠ WARNING

After servicing brakes and before moving motorcycle, pump brakes to build brake system pressure. Insufficient pressure can adversely affect brake performance, which could result in death or serious injury. (00279a)

⚠ WARNING

After repairing the brake system, test brakes at low speed. If brakes are not operating properly, testing at high speeds can cause loss of control, which could result in death or serious injury. (00289a)

SERVICE PARTS

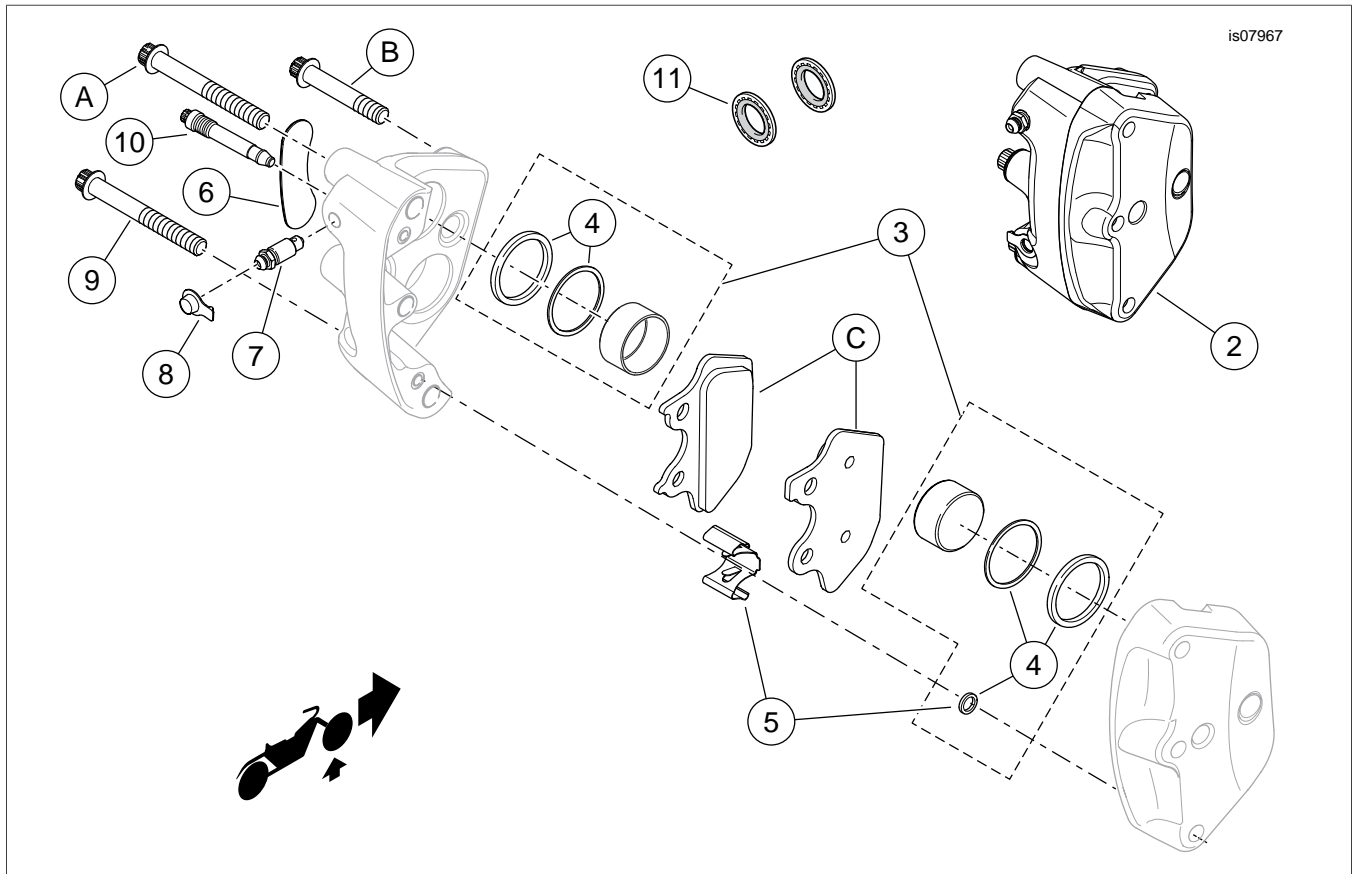

Figure 1. Service Parts, Brake Caliper Kit

Table 1. Service Parts Table

Item	Description (Quantity)	Part Number
1	Brake caliper kit, single front (Red) Brake caliper kit, dual front (Red)	41300126 41300120
2	<ul style="list-style-type: none"> Brake caliper assembly, left (Red, shown). For both kits. Includes Items 3-10. Brake caliper assembly, right (Red, not shown). Kit 41300120 only. Includes Items 3-10. 	41300121 41300124
3	<ul style="list-style-type: none"> ... Piston kit (includes Item 4) 	44313-01A
4	<ul style="list-style-type: none"> ... Seal kit 	44315-00A
5	<ul style="list-style-type: none"> ... Spring kit, anti-rattle 	44337-00B
6	<ul style="list-style-type: none"> ... Decal 	44404-00
7	<ul style="list-style-type: none"> ... Bleeder screw 	44400-00
8	<ul style="list-style-type: none"> ... Cap, bleeder 	44147-87A
9	<ul style="list-style-type: none"> ... Bridge bolt (2) 	44177-00
10	<ul style="list-style-type: none"> ... Pin, caliper pad (2) 	44314-00
11	<ul style="list-style-type: none"> Sealing gasket (2 for Kit 41300126) (4 for Kit 41300120) 	41731-01
Items mentioned in text, but not included in kit:		
A	Bolt, caliper mounting (upper) (Part No. 44163-00)	
B	Bolt, caliper mounting (lower) (Part No. 44160-00)	
C	Pad kit, front brake (Part No. 44082-00D)	