



## MICROFINE® 2 CONVEYOR PARTS AND SERVICE MANUAL



---

Thank you for choosing an LNS Chip Conveyor. We are proud to have you among our LNS family of users.

LNS Chip Conveyors simply and reliably remove waste from machining operations. Machine efficiency is increased and operator safety is improved since the conveyor work with little operator attention and without interrupting production time. LNS Conveyors are available for many types of machine tools or other applications. They can be arranged to deliver wet or dry waste to containers or to conveyor or chute-type disposal systems. For further information, contact:

Inside Sales Department  
LNS Turbo  
203 Turbo Drive  
Kings Mountains, NC 28086

This Service Manual is intended to assist with the normal maintenance that will assure long service life of your LNS Chip Conveyor. It is in two parts – a Service Instruction Section, followed by a Parts Section, which includes drawings and parts lists for the basic elements of the conveyors.

## NOTICE

ALL INFORMATION CONTAINED IN THIS MANUAL IS INTENDED TO BE CORRECT; HOWEVER INFORMATION AND DATA IN THIS MANUAL ARE SUBJECT TO CHANGE WITHOUT NOTICE. LNS CONVEYOR MAKES NO WARRANTY OF ANY KIND WITH REGARD TO THIS INFORMATION OR DATA. FURTHER, LNS CONVEYOR IS NOT RESPONSIBLE FOR ANY OMISSIONS OR ERRORS OR CONSEQUENTIAL DAMAGE CAUSED BY THE USER OF THE PRODUCT. LNS CONVEYOR RESERVES THE RIGHT TO MAKE MANUFACTURING CHANGES WHICH MAY NOT BE INCLUDED IN THIS MANUAL.

LNS supplies data necessary for the proper instruction, test, operation and maintenance of this product. LNS retains all proprietary rights in and to the information so disclosed and such shall not be reproduced, copied, or used in whole or in part for purposes other than those for which it is furnished.

### 1. Table of Contents

<b>CONTENTS</b>	<b>PAGE</b>
Instructions for Ordering Parts .....	2
Warranty .....	2
Installation and Startup Maintenance .....	3-7
Lubrication and Routine Maintenance .....	7
Clutch Operation and Adjustment .....	7
LNS Conveyor Torque Limiting Adjustment .....	8
Conveyor Belt Removal & Installation .....	9-12
Conveyor Belt Tensioning .....	12-13
Motor, Drive Shaft & Sprocket Alignment .....	14
Drive Chain Tension .....	15
Lower (Scraper) Conveyor Service Instructions .....	15-23
Conveyor Terminology .....	24-25
Trouble Shooting .....	26-28
Maintenance Schedule .....	29
Standard and Heavy Duty Belt Assembly .....	30
Super Heavy Duty Belt Assembly .....	31
Top Mount Parallel Gear Motor Parts .....	32-33
Lower Conveyor – Filter Drum & Back-wash Parts .....	34-35
Lower Conveyor – Filter Drum Assembly .....	36
Lower Conveyor – Tail & Idler Shafts/Sprockets .....	37
Lower Conveyor – Discharge & Drive .....	38
Lower Conveyor – Scraper Belt Parts .....	39
Microfine 2 Back Wash Pump Parts List .....	40-42
Microfine 2 Back Wash Pump Installation & Maintenance .....	43-47
Air Header Installation & Operation .....	47-49
Chip Stripper Bar Installation & Operation .....	50-51
Microfine 2 Electrical Information .....	52-58

### 2. Instructions for Ordering Parts

## INSTRUCTIONS FOR ORDERING PARTS

#### Furnish the following information on your order:

- 1 Model and serial no. of machine
- 1 Catalog number and name of part
- 1 Quantity wanted
- 1 Purchase order number
- 1 Bill to address

#### Furnish exact shipping instructions:

- 1 Complete shipping address
- 1 Mode of delivery
- 1 Parcel post, truck line, etc

**How to find the model and serial number of your machine:**

The machine model number and serial number is stamped on the machine nameplate located on the motor cover.

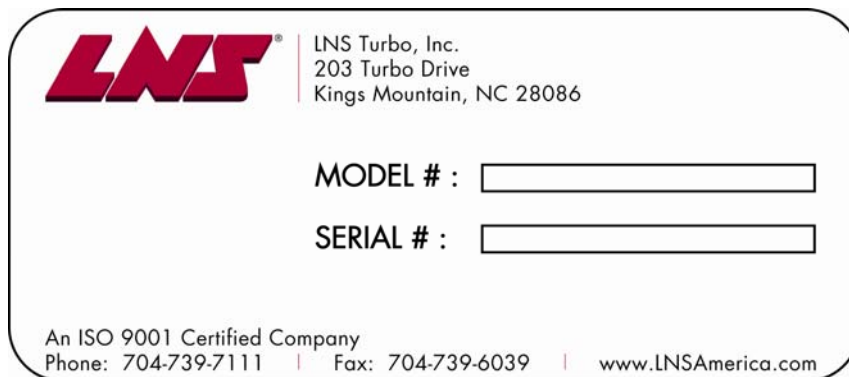

**DIRECT YOUR ORDER TO:**

**LNS Turbo**  
**203 Turbo Drive**  
**Kings Mountains, NC 28086 U.S.A.**  
**Telephone: (704) 739-7111 Fax: (704) 739-6039**

**WARRANTY**

Seller warrants that within 12 months from original shipment, if its products are operated by the original specified user: Seller will repair or replace, at its option, free of charge except freight, FOB shipping point, any parts it finds nonconforming on these conditions:

- a. on request, user promptly allows seller to inspect, and user returns all requested parts to seller's plant, and
- b. user has operated and maintained products in accordance with seller's maintenance and operational literature and good business practice; and
- c. products have not been misused, abused, damaged by accident or altered without seller's written consent; and
- d. user employs trained maintenance and operating personnel; and
- e. buyer meets all payment obligations;

Seller warrants products manufactured by others to the extent warranted by their original manufacturers, on these conditions. Parts which have expected life shorter than one year under normal usage are excluded. USED PRODUCTS ARE SOLD AS IS. SELLER MAKES NO WARRANTY FOR USED PRODUCTS EXCEPT AS TO TITLE. BUYER MAY INSPECT AND TEST BEFORE SHIPMENT AND ACCEPTS USED PRODUCTS ON THESE TERMS.

THIS WARRANTY IS EXCLUSIVE AND IN LIEU OF ALL OTHER WARRANTIES WHETHER WRITTEN, ORAL, OR IMPLIED, (INCLUDING ANY WARRANTY OF MERCHANTABILITY OR FITNESS FOR PARTICULAR PURPOSE.)

**INSTALLATION AND STARTUP**

Your LNS Conveyor has been run prior to shipment to insure proper operation. However, it is recommended that the following checks be made before startup:

## SERVICE SECTION

Most smaller assemblies of the conveyor, such as the drive and safety clutch, can be disassembled by careful reference to the parts drawings on the pages that follow. However, the belt and related parts can be removed by following the sequence described below. Refer to the Part Section in this manual for belt part designation/catalog

### Conveyor Drive

Check frame and belt for damage during shipment or storage.

Locate conveyor in operating position.

All drive elements (pulleys and sprockets) should be located close to their bearing supports. Each set of pulleys and sprockets should be carefully aligned to prevent excessive wear and noise.

Drive chains and belts should be properly tensioned.

Check speed reducer to see that oil is at proper level. If there is a shipping plug in gearbox vent, remove it.

### Leveling

Level should be placed across tail section and on bottom cover at discharge, perpendicular to travel of the belt. Adjust conveyor support leg, if so equipped, or shim as necessary to level.

- Electrical Controls
- Belts/Drum Rotation
- Proper Coolant Level

### Electrical Controls

If the conveyor is supplied with electrical controls, check voltage of system supplied to be sure it matches with that to be used. Read the Electrical Controls section in this manual for more details before installing the conveyor.

A qualified electrician in accordance with local codes must connect electrical equipment to power source. If conveyor power source is basic machine, refer to basic machine manufacturers wiring diagram.

**DO NOT DRILL HOLES IN CONVEYOR FRAME TO MOUNT POWER BOXES OR ACCESSORIES WITHOUT FIRST CONSULTING LNS.**

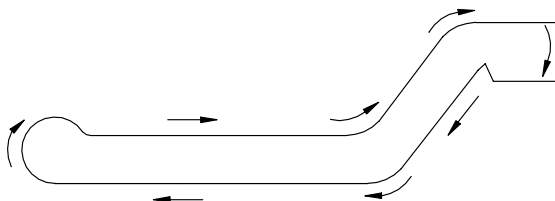

Arrows show **forward** movement of belt on a **hinged belt** conveyor. The normal belt direction is **opposite** of arrows on a **drag link** conveyor.

Prior to installation of the MICROFINE® 2, the coolant tank should be cleaned of any chip residue from prior machining operations or debris from shipment packaging. This will ensure a clean and trouble free start-up.

**DANGER!**

**DO NOT TURN ON ELECTRICAL SUPPLY PRIOR TO COMPLETING THE PRE-START CHECK LIST THAT FOLLOWS.**

### **PRE-START CHECK LIST**

The MICROFINE® 2 conveyor is equipped with several components and features not found on conventional chip conveyors. Each of these components is described below. Connection or pre-start inspection instructions follow the description of each component.

1. An air header assembly is located at the conveyor discharge end and under the hinge belt return face.

Plant air must be connected to the air regulator provided with the assembly - adjust air pressure reading at the regulator within the range of 6 to 10 PSI.

Higher or lower pressure may be used later depending on actual operating requirements.

Excessively high pressure will cause coolant loss and mist generation.

2. A back-wash pump is generally supplied with your MICROFINE® 2 conveyor and is pre-connected. If your MICROFINE® 2 conveyor was ordered without a back-wash-pump that supplies continuous coolant flow through the nozzles to clean the filter drum, insure that a pump source is used that supplies consistent, continuous coolant flow. Spindle pumps are not recommended for this application because they are used intermittently and will result in inconsistent pressure and flow depending on when the spindle coolant is being used. Failure to supply continuous back-wash flow to clean the filter drum can result in coolant overflows from the conveyor into the clean side of the coolant tank..

The back-wash pump assembly is to be vertically mounted on your coolant tank so that the liquid level mark is at least 25/32" (20 mm.) below the pump flange when the system is turned off and all the coolant has returned to the reservoir. The discharge line should have the same diameter as the discharge flange thread to minimize pressure losses. The immersion depth can be changed by adding an extension pipe at the base of the pump. At start-up the liquid level must be above the pump chamber; afterwards it is sufficient if the coolant level is above the suction port or the extension pipe. Note that the pump is provided with a short length electrical cable; this is to ensure that the pump is located as near as practical to the filter. The cable is supplied with a 4 pin connector that is to be attached to a mating outlet on the control enclosure (located on the enclosure bottom face). Also, connect the back-wash fluid supply hose (clear vinyl) to both the pump and back-wash piping at the filter housing side. Barbed hose fittings and screw adjustable hose clamps are provided for ease of assembly.

3. The drum filter assembly - contained within the lower conveyor frame to the rear of the conveyor incline.

No special pre-start preparations are required. However, it is advisable to inspect the inlet area to the rear of the housing and the conveyor load section belt. Remove any foreign objects or material that may remain from shipment packaging. A visual check of the filter area is recommended to ensure absence of foreign material within the filter housing; view through the inspection window located on each side of the conveyor frame.

### **CONVEYOR ELECTRICAL SERVICE CONNECTION**

Upon completion of the above pre-start activities, check to be sure both the conveyor and filter control switches are in the "OFF" position; the filter power control switch is a "mushroom" type, PULL ON, PUSH OFF. Depending on the type of conveyor drive, the conveyor start/stop switch may be located in a separate enclosure

near the filter control. After verification that both control switches are in the "OFF" position, connect the conveyor to your power supply. Once power supply connections are completed, verify correct drum filter rotation and conveyor belt travel direction.

Note: The direction of the drum filter rotation should be as shown below. If not, the scraper belt is traveling in the wrong direction. To correct this problem reverse two of the three "hot" leads to the lower conveyor drive motor.

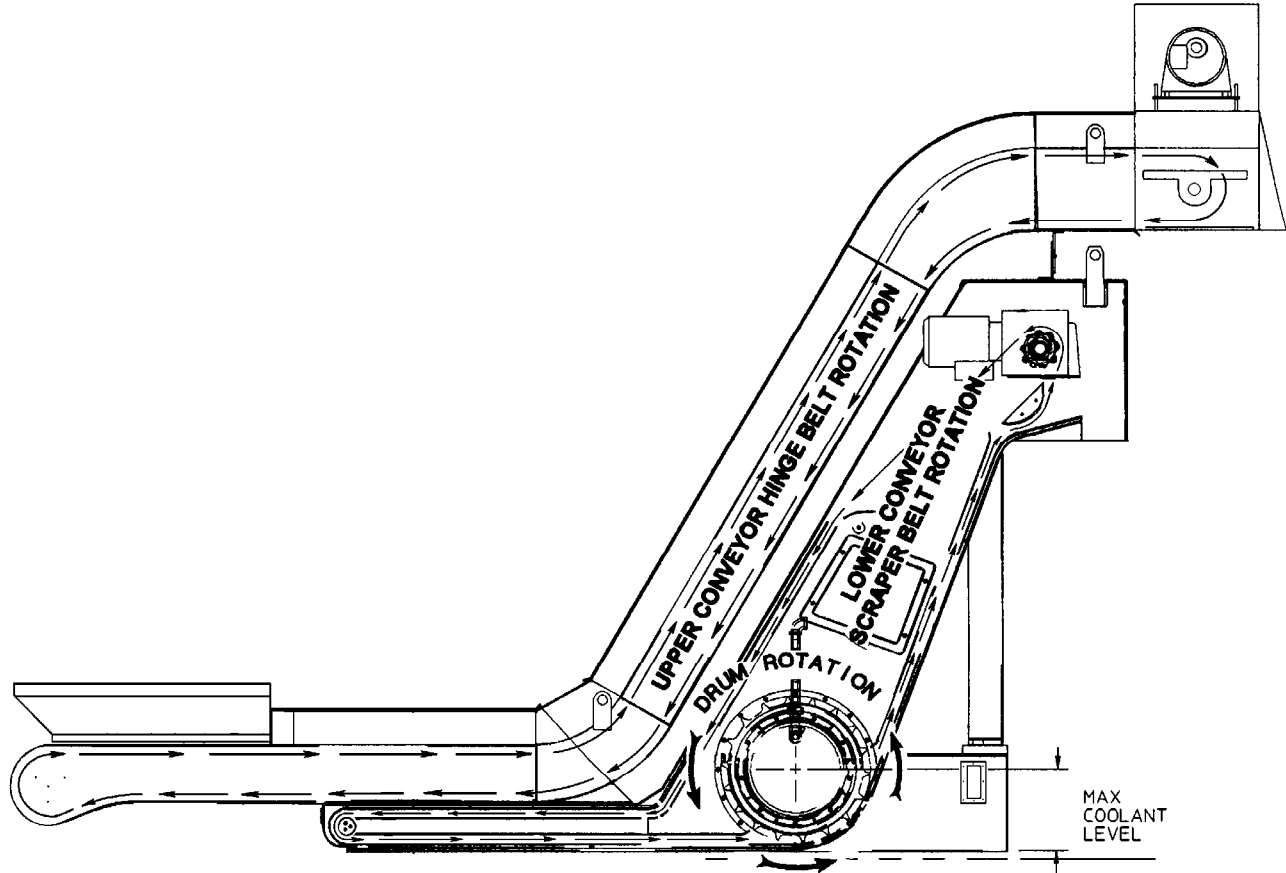

### COOLANT FILLING

Fill the coolant tank with water soluble coolant solution of your choice. After initial start-up, you may find it necessary to add coolant to restore the desired fluid level. This is because the conveyor load section acts as an additional reservoir and complete drain down of the conveyor does not occur even during system idle periods. Note: Do not fill the coolant tank level with coolant above the center line of the filter drum.

### PERIODIC INSPECTION

The MICROFINE® 2 conveyor has been designed to be maintenance free; however, the following periodic checks should be completed at the recommended service intervals to ensure continued and trouble-free operation.

**AFTER FIRST 100 HOURS**

After the first 100 hours of operation and the regular intervals complete the following:

1. View the operation of the drum and back-wash system through the window located on each side of the lower conveyor frame.

**WARNING!**

**DO NOT REACH INTO THE DRUM HOUSING WHEN THE SYSTEM IS RUNNING. SERIOUS PERSONAL INJURY COULD RESULT.**

While the conveyor is running and the back-wash system "on", check for back-wash system function. A strong, uniform fluid flow should be properly cleaning the filter drum across the full width of the drum. If there is an absence of spray or the spray pressure is weak, there are several possible causes. See the trouble shooting section of this manual for further information.

2. By viewing the filter screens through the window located on each side of the lower conveyor frame, check the condition of the filter screens and viton v-ring seals attached to the filter drum.

**WARNING!**

**DO NOT REACH INTO THE DRUM HOUSING WHEN THE SYSTEM IS RUNNING. SERIOUS PERSONAL INJURY COULD RESULT.**

The screens should be free of tears and firmly positioned by the filter clamp. The bolts that secure the three metal wipers plates that attach the screen to the drum must be tight. Inspect the v-ring seals for damage (tears or punctures). In the event that the filter screen or v-ring seals are damaged, they must be replaced immediately. Failure to do so will result in contamination of the clean side of the tank.

BE SURE TO SWITCH THE CONVEYOR "OFF" prior to checking tightness of the filter and wiper blade mount screws. All screws should be firmly seated, but not tighten enough to cause compression of any metal parts. To check all screens and mounting screws, the conveyor should be "jogged" to rotate to each exposed section of the filter screen around the circumference of the drum. **DO NOT LEAVE THE CONVEYOR RUNNING** while performing this inspection process.

Prior to applying power back to the conveyor, be sure to remove any tools, shop rags or towels you may have used while completing inspection and maintenance. Any foreign article(s) left on the filter drum can cause an immediate lock-up at re-start; this may lead to failure of drum components, belt and/or gear-drive.

3. Back-wash in-line strainer filter inspection: The back-wash in-line strainer is clogged if a 5 PSI differential between the two gauges on each side of the in-line strainer exist. In this case, the strainer filter is to be removed and cleaned. To clean the strainer, turn the conveyor off (back-wash coolant pressure and flow must be shut off) and remove the strainer filter housing by removing the bolt that secures the canister to the filter housing. Remove the filter element located inside, clean the mesh element, inspect the gasket for damage and if in good condition reassemble the strainer filter.

**CAUTION !**  
**ALWAYS DISCONNECT POWER TO THE CONVEYOR  
BEFORE ATTEMPTING ANY MAINTENANCE PROCEDURES.**

## LUBRICATION AND ROUTINE MAINTENANCE

After First 100 Hours of Operation and at regularly scheduled intervals to suit operating conditions:

- Check belt, wipers for excessive wear.
- Inspect conveyor belt parts for excessive wear. If excessive wear is noted, belt should be removed and repaired. (Refer to service section for belt removal instructions).
- Change oil in speed reducer (if applicable). Use any brand 90-wt. gear oil.
- Grease pillow block bearings, using grease gun. Do not grease too often – bearing seals could be damaged.
- Check belt tension
- Oil drive chains.

**CAUTION !**  
**ALWAYS DISCONNECT POWER TO CONVEYOR  
BEFORE ATTEMPTING ANY MAINTENANCE  
PROCEDURES.**

## CLUTCH OPERATION AND ADJUSTMENT

A ball and detent clutch protects the conveyor drive unit from damage in case of jamming or overload. The clutch is preset at factory.

### Clutch Adjustment

The clutch should not require any adjustment when working under normal machining operations. If a problem occurs refer to the Trouble Shooting Section on page 25 of this manual.

Please contact LNS' Service Department before adjusting the clutch setting. If clutch adjustment is too tight, the clutch will not function as a safeguard for the motor.

Please fill in the blanks below with the conveyor model and serial number for your reference.

**CAUTION !**  
**If clutch adjustment is too tight, clutch will not  
function as a safeguard for the motor.**



MODEL NO. \_\_\_\_\_

SERIAL NO. \_\_\_\_\_

**THE COMPRESSION SPRING IS PRESET AT THE FACTORY.  
CONTACT LNS BEFORE MAKING ANY ADJUSTMENT.**

## LNS CONVEYOR TORQUE LIMITING CLUTCH

Clutch shown here has a single spring. Your conveyor clutch spring quantity may vary.

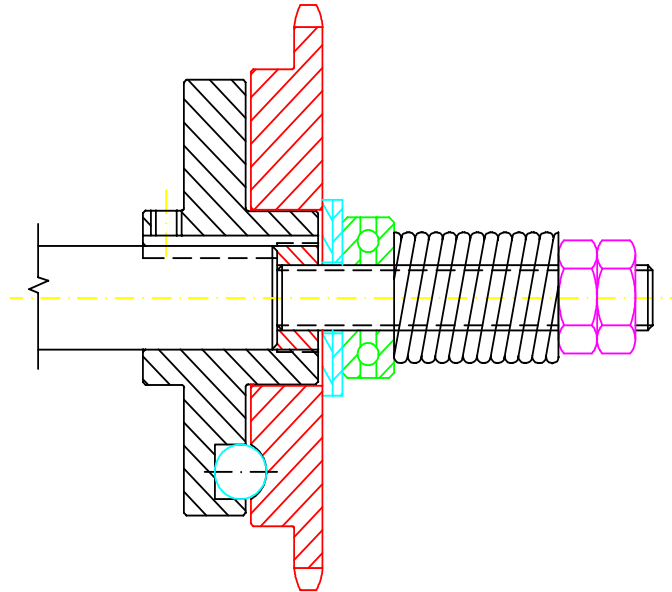

### HINGE BELT REMOVAL AND INSTALLATION INSTRUCTIONS FOR UPPER CONVEYOR

1. Disconnect power to the conveyor before performing any work on the belt.
2. Remove the cover over the clutch and drive chain.

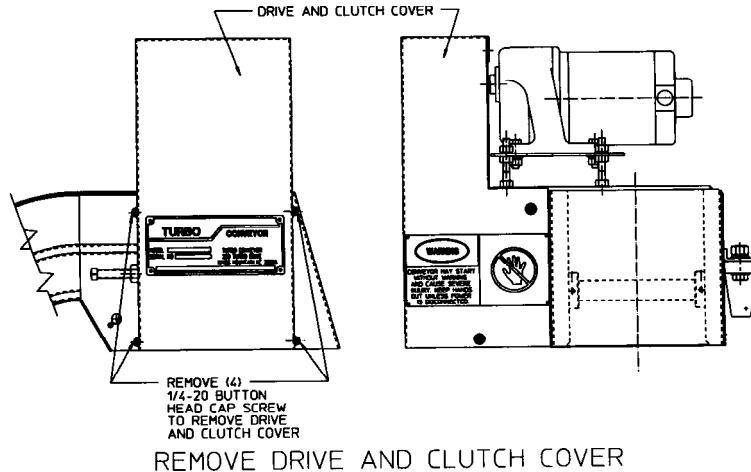

3. Take the master link out of the roller drive chain between the clutch and motor and remove the chain.
4. Loosen the lock nuts on the belt tension adjusting screws (located just behind each of the pillow block bearings on the drive shaft) and back off the adjusting screws until they are flush with the face of the adjusting bracket.
5. Loosen the two bolts holding each pillow block bearing.
6. Slide the drive shaft toward the tail of the conveyor as far as the adjusting slots for the pillow block bearings will allow. This will provide maximum slack in the belt.

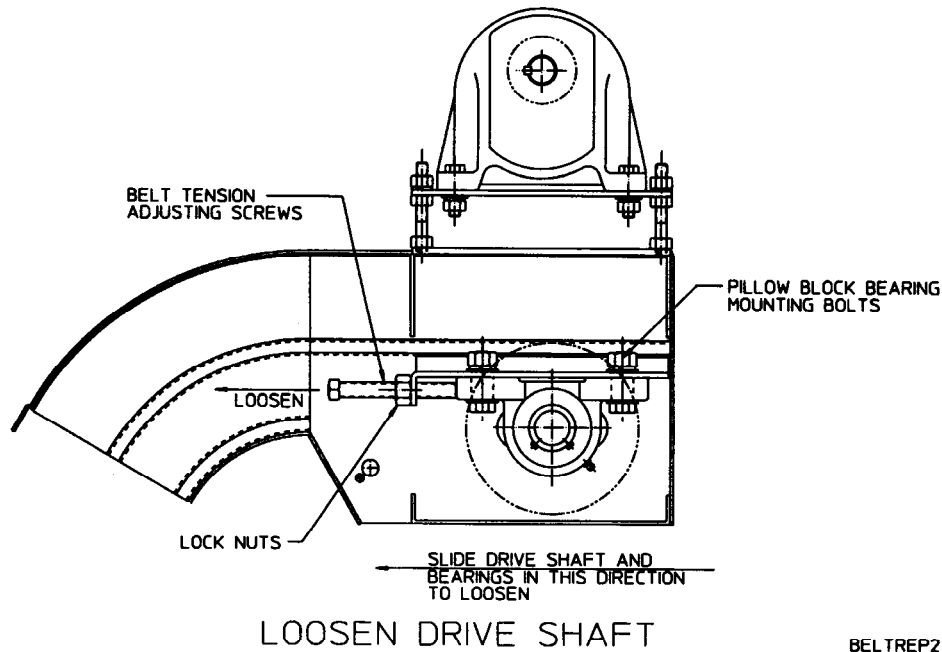

7. Working through the drive shaft adjustment slot, remove the cotter pin from one of the belt hinge pins on the end of the pin nearest the clutch.

NOTE: Some conveyor belt designs have headed link pins. If the head of the link pin is on the clutch side of the conveyor, the clutch must be removed before the headed pin can be removed through the drive shaft adjustment slot. The clutch assembly can be removed by loosening two set-screws that secure it to the drive shaft. When reinstalling the clutch make sure to apply suitable Locktite product, which is normally used for fasteners, on the set-screws before re-assembly. (Follow the manufacturer's instructions for applying Locktite.

- Being careful to catch the flat washer and roller, pull the hinge pin out through the adjustment slot on the side opposite the clutch. The hinge pin cannot be removed from the clutch side because it won't clear the clutch sprocket.

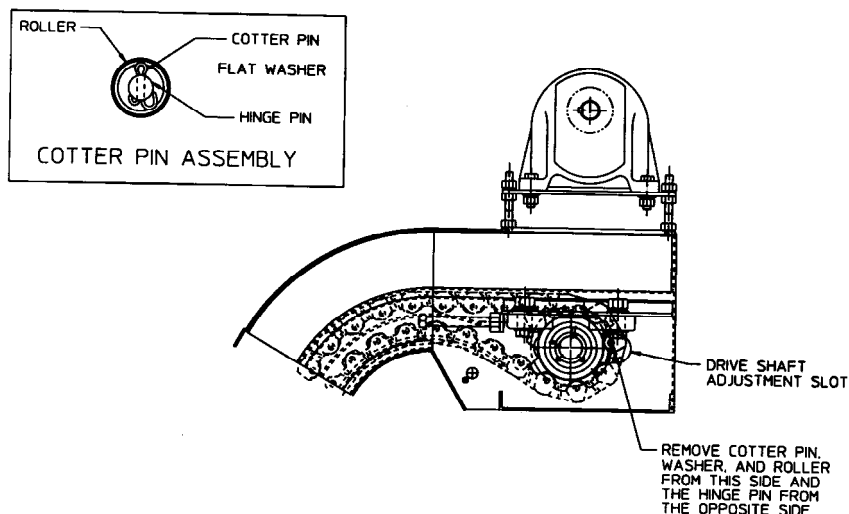

HINGE PIN REMOVAL

BELTREP3

- Grasp the end of belt below the drive shaft and pull the belt out of the conveyor. Be sure to wear gloves to avoid being cut by sharp edges on the belt. When only a few feet of belt remain in the conveyor, the belt on the floor will have enough weight to begin pulling the remainder out on its own. As the last of the belt begins to run out faster, don't attempt to stop it; just stand clear and let it run out onto the floor. Note that the belt was moved in the direction opposite normal belt travel.

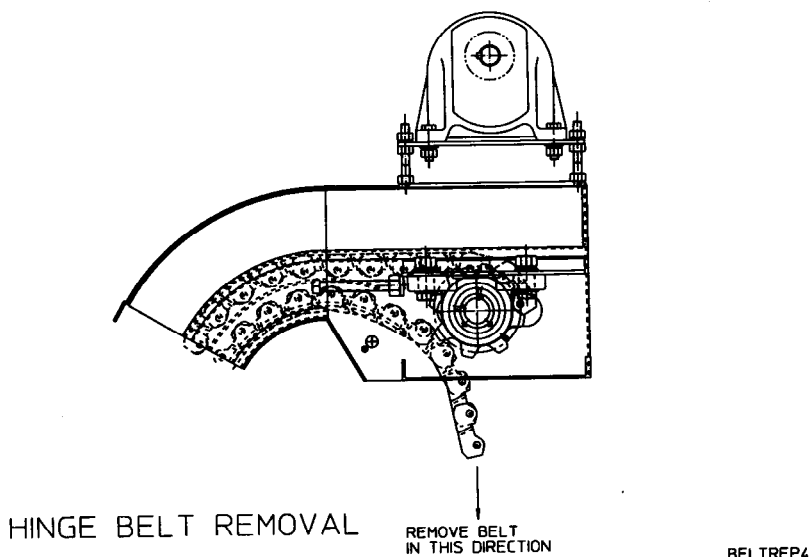

HINGE BELT REMOVAL

BELTREP4

- Before moving the old belt out of the way, pay particular attention to the way the side wings overlap. When the belt is running in the normal direction of travel, the leading ends of the side wings are outboard, and the trailing ends are inboard.

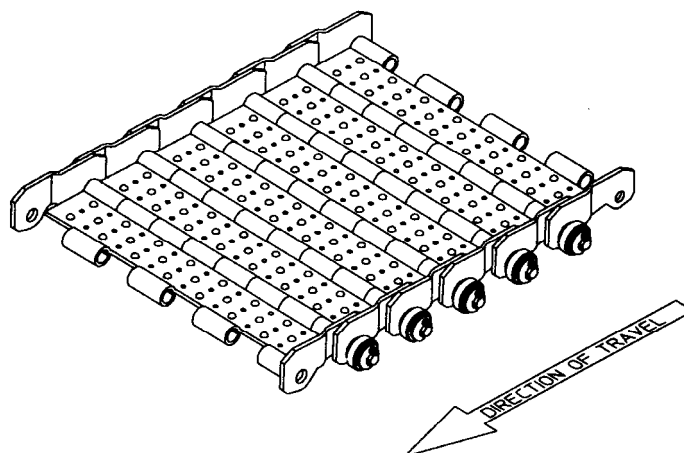

11. Place the new belt on the floor beneath the conveyor discharge, being careful to orient it in the same direction as the old one that was removed.
12. If there is not already a hinge pin in the end of the belt, use the pin and rollers that were removed to separate the old belt. There must be a pin and rollers in the extreme end of the belt for ease of insertion.
13. With a person standing on either side of the belt, lift up the lead end and start it in the lower track, from which the old belt was pulled out. Be sure and wear gloves to prevent injury, and be sure to maintain a secure hold on the belt until at least five feet have been fed into the conveyor frame. At this point, the weight of the belt inside the frame should be enough to prevent it running back out on it's own.

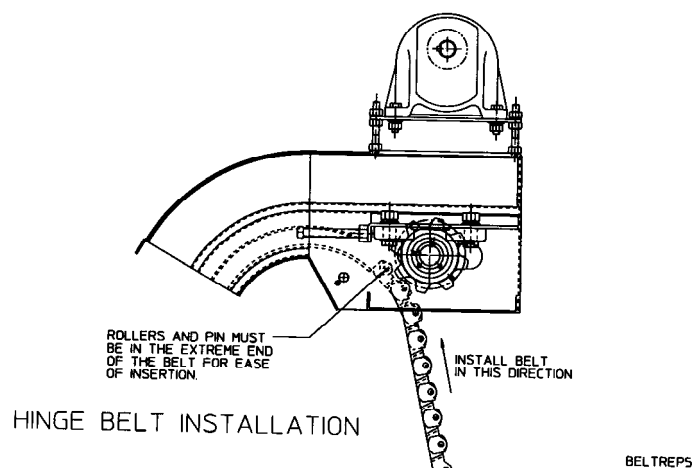

14. Continue feeding the belt into the conveyor frame. One person may have to use a length of 2 x 4 or a pry bar to "help" it along from time to time. Force should not be required. Many times the belt can be pushed in all the way around from the discharge end. If the belt hangs up, look for some obstruction; don't force it.
15. When the lead end of the belt reaches the drive shaft, carefully feed it up over the drive sprockets.
16. Remove the hinge pin and rollers that were used to help guide the belt through the track.
17. With the ends of the belt engaged in the teeth around the top and bottom of the drive sprockets, the two ends should join. At this point, it may be necessary to remove one or more hinge plates from the new belt. Most new belts are supplied longer than necessary.

18. Reverse steps 1 through 7.
19. When adjusting belt tension, clamp a pair of vise grip pliers on one of the formed cleats on the belt. Use the vise grips to "rock" the belt back and forth to feel the slack and drag on the belt. There should not be more than enough slack to allow rocking the drive shaft through 15 degrees of rotation without moving the belt. On a new belt, zero slack is O.K., but if the belt is difficult to move with the vise grips, it's too tight. Correctly adjusted, it should be possible, if difficult, to move the belt with one's gloved hands by turning the clutch sprocket.
20. Visually confirm the belt is located in the center of the frame. Adjust if necessary by loosening the setscrews in the pillow block bearings and shifting the drive shaft; clutch and all; to the left or right as appropriate.
21. Re-connect power and test run the conveyor. The belt should run freely and the only sound should be a subdued clicking as each hinge plate passes over the drive sprocket.

## WARNING !

**Hinge plates can pinch hands and fingers.**

## SCRAPPER BELT REMOVAL AND INSTALLATION INSTRUCTIONS

### CONVEYOR BELT TENSIONING

Correct conveyor belt tension is essential to ensure proper operation and extended life of conveyor components. The belt has been properly tensioned during factory assembly. As normal wear occurs the belt may become slack and need adjustment.

The following factors may be used to determine if the belt needs adjustment.

- Belt Too Loose: Belt Slack at exit point of the drive sprocket before re-entry into frame. (See fig. 1).
- Belt Too Tight: Belt has intermittent jerks and a popping sound while conveyor is in operation.
- Uneven Tension (side to side): (1) Belt tends to track to one side (2) Excessive wear on outside of side wings.

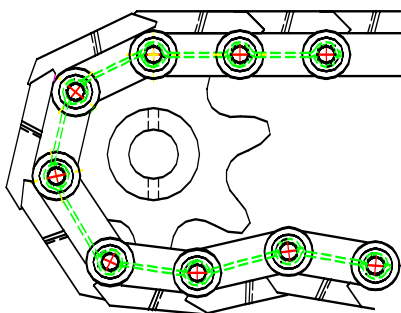

**INCORRECT**

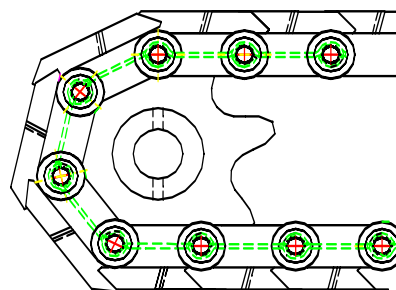

**CORRECT**

**FIG. 1**

Check to see that clutch body (75A-50) is square to the bearing-mounting bracket. (See Fig.2). If it is not, this will generally indicate which direction the belt is off on side to side tension.

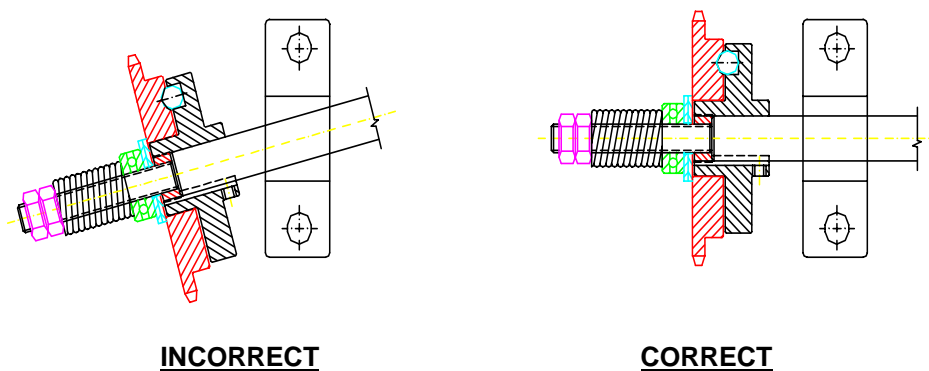

**FIG. 2**

Once it is determined that retensioning of the belt is necessary, the following procedure should be followed:

### INSTRUCTIONS FOR CHECKING CONVEYOR BELT TENSION

1. Position belt with a link pin directly below the conveyor drive shaft.
2. Hold a straightedge across the bottom of the conveyor discharge at the very rear.
3. Using a 6-inch scale, measure vertically from the straightedge up to the underside of the belt.
4. Push up on the underside of the belt and repeat the measurement as in step 3.
5. Under the force applied by the average worker, the measurement in step 4 should be approximately 1/16 inch (1.5mm) greater than the measurement in step 3.

### BELT TENSIONING PROCEDURE

1. Install belt as stated in Parts and Service Manual, except do not install drive chain or tension belt. (Drive chain and preload exaggerates and/or alters torque reading.)
2. Tighten pillow block bearing bolts, then loosen five (5) ¼ turns. (This step ensures that bearing is parallel to bearing mount surface, and that lockwasher is not adding additional torque to reading.)
3. Set torque wrench to 25 inch pounds. Tighten each bearing adjusting bolt alternately until 25 inch pounds is obtained and torque wrench no longer turns adjusting bolt, but clicks at rotation.
4. Manually rotate belt back and forth. (This distributes tension evenly throughout belt.)
5. Repeat steps (3) and (4) until belt rotation no longer results in decreased torque setting. (This step ensures that both sides of belt are tensioned equally.) Lock adjusting bolts.
6. Run machine for (2) hour break-in period.
7. Remove drive chain. Loosen adjusting bolt locknuts. Loosen bearing bolts as noted in step (2). Repeat steps (3), (4) and (5). The belt must be retorqued to obtain correct tension after break in period (see guide below).

NOTE: Belts with discharge heights in excess of 50" or load length in excess of 8 ft. may require higher torque settings. Contact LNS if assistance is needed.

### TORQUE GUIDE

Overall Length to 225" .....25 in. lbs.  
 Overall Length 225" to 375" .....35 in. lbs.  
 Overall Length 375" and over .....45 in. lbs.

NOTE: Material use, application and incline angle can affect required torque settings. Drag link type conveyors may also experience torque variances due to conveyor length and chip loads.

**CAUTION!**  
**ALWAYS DISCONNECT POWER TO CONVEYOR BEFORE ATTEMPTING ANY MAINTENANCE PROCEDURES.**

**MOTOR AND DRIVE SHAFT & SPROCKET ALIGNMENT**

Proper alignment of sprockets and shafts are essential for smooth operation of conveyors and long lasting service of the conveyor chain and the drive chain. To ensure correct alignment, follow these steps.

- 1. Level the motor and drive shaft using a level.

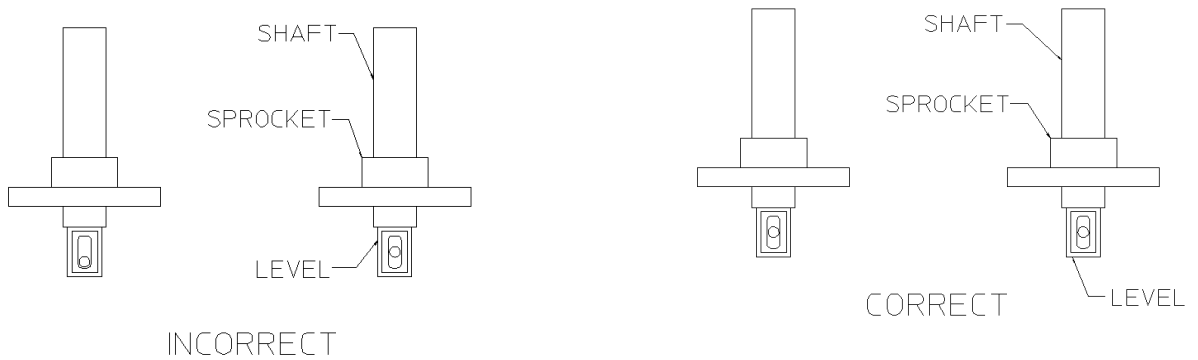

- 2. Align the motor and drive shaft for parallelism using a straight edge or a scale. The sprocket should be parallel to the shaft within +/- 1 mm.

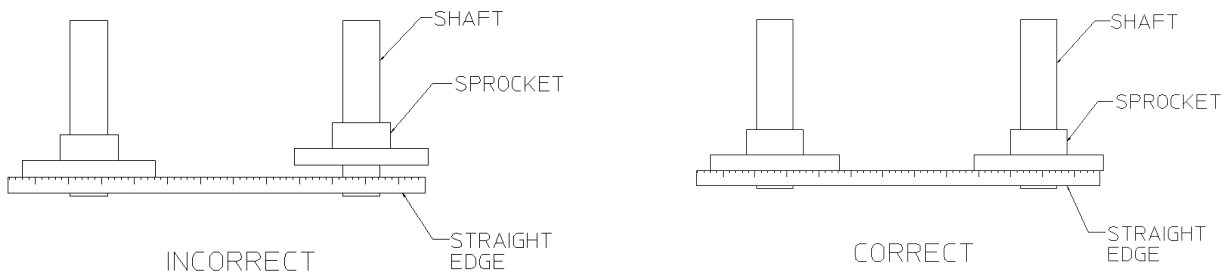

- 3. Align the motor sprocket with the clutch or drive sprocket axially on the shafts using a straight bar, straightedge or stretched wire as illustrated below. Centering accuracy should be within 2 mm.

## DRIVE CHAIN TENSION

Proper Tension for the drive chain is extremely important because:

1. When the chain is too tight, the additional load results in faster wear on the chain joints, sprocket teeth and shaft bearings.
2. When the chain is too slack, vibration could cause excessive chain wear, noise or shock loading.

For most horizontal and incline drives, the chain should be installed with an amount of sag in the unloaded span amounting to about 2 percent of the sprocket center distance length. Sag, then, becomes the measure of chain tension. For example if the span length between the sprocket centerlines, as shown below, are 18" then the sag should be  $3/8$ " if the belt is tensioned correctly.

To measure the actual amount of sag, one side of the chain should be pulled up tight, allowing all of the excess chain to accumulate in the opposite span. A straight edge over the sprockets and a scale can be used to measure the sag. The chain tension should be checked on a regular basis and adjustments made as necessary.

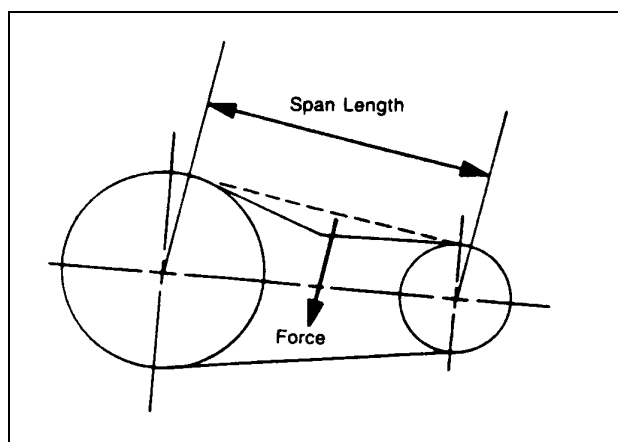

## SCRAPER BELT INSTALLATION AND REMOVAL OF LOWER CONVEYOR

1. Disconnect Electrical Power to the conveyor. (See electrical safety warnings in the Electrical Section of this manual before performing this step).
2. Remove the coolant tank covers that surround the conveyor
3. Remove the mounting bolts that attach the conveyor leg and the tail anchor brackets to the coolant tank.
4. Connect a chain or strap, which is properly rated for the lifting weight of the conveyor, to the lifting hooks or eyes which are located at the discharge end and the horizontal load section of the conveyor.
5. Lift the conveyor out of the coolant tank and let the conveyor tilt forward and rest on the leg.
6. Remove the drain chutes of the conveyor.
7. Remove the mounting bolts for the two brackets which are located at the tail end, underneath the conveyor
8. Remove the mounting bolts along each side of the conveyor that mounts the upper conveyor to the lower conveyor.
9. Place a support under the discharge of the lower conveyor before lifting the upper conveyor.
10. Separate the upper conveyor from the lower conveyor and sit the upper conveyor aside.
11. Loosen the bearing bolts and adjusting nuts on both sides of the lower conveyor.
12. Remove the drum assembly. (Reference the "Drum Removal and Assembly" instructions in this manual).
13. If the conveyor belt is jammed, remove the drive motor and locate the master link on the belt. Remove the clips on the master links (both sides).
14. Remove the belt by pulling it out through the discharge end of the conveyor.
15. Inspect the drive, tail and idler sprockets for wear. If worn replace and realign per "Sprocket Replacement and Alignment" procedures in this manual.



16. Inspect the drive, tail and idler sprocket shafts for wear. If worn determine the cause of the wear and correct this problem. Wear on the shafts are normally caused by an interference.
17. Inspect the conveyor frame for wear. This is normally caused by improper belt align or tensioning. See the sections concerning "Belt Alignment" and "Belt Tension" in this manual for proper belt alignment and tensioning..
18. After the conveyor belt has been removed or replacement is ready to be installed, lay it out so that it is oriented properly to go back into the conveyor. See the attached sketch for proper belt orientation and belt travel direction.
19. Push the belt evenly into the lower track of the conveyor frame. Continue to feed the belt into the frame until it descends down the conveyor frame incline and gets to the lower horizontal load section. At this point it must be aligned and started into the lower belt track. Continue to feed the belt until it reaches the tail sprockets.
20. Once the belt is at the tail sprockets, pull the belt over the sprockets evenly so that the belt is in proper timing with the sprockets on both sides. If the belt and the sprockets are not properly synchronized it can cause damage or failure of the belt, frame or drive components.
21. Continue to pull the belt and insure it is feed under the idler sprockets. Again make sure the belt is properly synchronized and aligned with the idler sprockets.
22. Pull the belt over the drive sprockets and connect the master links on both sides with the clips. Insure that the clips are seated properly.
23. Before installing the drum, inspect the seals, brass bearings, and screens for damage. Replace any damaged parts.
24. Insure that the clamps are rotating immediately.
25. Slide the drum in from the left side of the conveyor so that the drum sprocket teeth clear the belt. While installing the drum, tilt the drum so that the sprocket teeth clear the chain. Once in place align the sprocket teeth to insure they are in time and properly aligned with the chain on both sides.
26. Clean and grease the right-hand and left-hand side plates with grease or an equivalent type.
27. Install the left-hand plate and start all of the mounting screws.
28. Install the right-hand plate and start all of the mounting screws.
29. Install the back-wash plumbing.
30. Tension the conveyor belt to 20 inch pounds on each side by tightening the conveyor drive adjusting screws. Check the belt deflection to insure that is the same on both sides.
31. Once the belt is properly tensioned, tighten the pillow block bearing mounting bolts while holding the nuts in place with a wrench.
32. Tighten all of the bolts on both the right-hand and left-hand side plates.
33. Install the key into the keyway in the drive shaft and slide the drive motor back into position and start the two bolts into the bracket. Push the motor as far forward as possible and tighten the mounting bolts.
34. Tighten all of the set screws on the reducer.
35. Reconnect the electrical power to the lower conveyor and test run the conveyor. See the "Electrical Section" of the manual for safety instructions and warnings.
36. If the conveyor belt makes a popping noise, check the belt and sprocket alignment. Insure that the scrapper bars are square with the belt and are tracking properly. If not, make the necessary adjustments to correct this problem.
37. After the lower conveyor has been test run for 30 minutes without any problems, stop the conveyor and check the belt tension. If necessary loosen the pillow block mounting bolts and retension the belt to 20 inch pounds. (Follow steps 30 – 31).
38. Inspect the seal that mounts between the upper and lower conveyors. If damaged it must be replaced.
39. Put a small bead of silicone on the horizontal load section of the lower conveyor.
40. Lift the upper conveyor and properly locate it on top of the lower conveyor, aligning the mounting bolt holes.
41. Once the last two bolt holes (at tail end?) on the horizontal load section are properly aligned begin bolting the conveyor together on both sides.
42. Align the bolt holes at the bottom of the incline section and begin bolting the conveyor together on both sides.
43. Before tightening the bolts, insure that the upper and lower conveyor are flush and square so that the drain boxes on each side will bolt on and seal properly. If not realign the two conveyor frames with each other until the drain boxes will bolt on and seal.
44. Tighten all of the bolts securing the upper and lower conveyor.
45. Inspect the drain box gaskets to insure they are not damaged. If damaged these must be replaced.

46. Install the drain boxes and gaskets on each side and tighten the bolts. Check to insure that the gaskets make a good seal and are compressed completely around the peripheral of the drain boxes. (Note: on some conveyors there are two mounting bolts underneath the upper conveyor attaching the drain boxes.)
47. Once the conveyors are completed reassembled back together, install the conveyor back into it's original position in the coolant tank and bolt the leg to the tank at the discharge end and bolt the conveyor to the tail anchor bracket at the tail end.
48. Install the tank covers.
49. Roll the tank and conveyor back into the correct position under the machine tool.
50. Reconnect all electrical cables and wires to the conveyor. (See electrical safety warnings in the Electrical Section of this manual before performing this step).
51. Test run the conveyor to insure proper operation.

### **DRUM REMOVAL AND INSTALLATION INSTRUCTIONS (Requires two people)**

1. Disconnect Electrical Power to the conveyor. (See electrical safety warnings in the Electrical Section of this manual before performing this step).
2. Remove the coolant tank covers that surround the conveyor.
3. Remove the mounting bolts that attach the conveyor leg and the tail anchor brackets to the coolant tank.
4. Connect a chain or strap, which is properly rated for the lifting weight of the conveyor, to the lifting hooks or eyes which are located at the discharge end and the horizontal load section of the conveyor.
5. Lift the conveyor out of the coolant tank and let the conveyor tilt forward and rest on the leg.
6. Loosen the bearing bolts, torque nut, and the torque bolt to lessen the tension.
7. Remove the side plate with the plumbing mounting bracket.
8. Remove the bolts out of the side ring, then remove the ring on both sides.
9. Lift the drum teeth out of the chain, tilt the drum upward, then pull out of the other side.
10. Pull the belt over the drive sprockets and connect the master links on both sides with the clips. Insure that the clips are seated properly.
11. Before installing the drum, inspect the seals, brass bearings, and screens for damage. Replace any damaged parts.
12. Insure that the clamps are rotating immediately.
13. Slide the drum in from the left side of the conveyor so that the drum sprocket teeth clear the belt. While installing the drum, tilt the drum so that the sprocket teeth clear the chain. Once in place align the sprocket teeth to insure they are in time and properly aligned with the chain on both sides.
14. Clean and grease the right-hand and left-hand side plates with grease.
15. Install the left-hand plate and start all of the mounting screws.
16. Install the right-hand plate and start all of the mounting screws.
17. Install the back-wash plumbing.
18. Tension the conveyor belt to 20 inch pounds on each side by tightening the conveyor drive adjusting screws. Check the belt deflection to insure that is the same on both sides.
19. Once the belt is properly tensioned, tighten the pillow block bearing mounting bolts while holding the nuts in place with a wrench.
20. Tighten all of the bolts on both the right-hand and left-hand side plates.
21. Install the key into the key-way in the drive shaft and slide the drive motor back into position and start the two bolts into the bracket. Push the motor as far forward as possible and tighten the mounting bolts.
22. Tighten all of the set screws on the reducer.
23. Reconnect the electrical power to the lower conveyor and test run the conveyor. See the "Electrical Section" of the manual for safety instructions and warnings.
24. If the conveyor belt makes a popping noise, check the belt and sprocket alignment. Insure that the scrapper bars are square with the belt and are tracking properly. If not, make the necessary adjustments to correct this problem.
25. After the lower conveyor has been test run for 30 minutes without any problems, stop the conveyor and check the belt tension. If necessary loosen the pillow block mounting bolts and re-tension the belt to 20 inch pounds.
26. Inspect the seal that mounts between the upper and lower conveyors. If damaged it must be replaced.

27. Put a small bead of silicone on the horizontal load section of the lower conveyor.
28. Lift the upper conveyor and properly locate it on top of the lower conveyor, aligning the mounting bolt holes.
29. Once the last two bolt holes on the horizontal load section are properly aligned begin bolting the conveyor together on both sides.

### **CONVEYOR BELT TENSIONING (LOWER CONVEYOR)**

1. For best results, remove the motor.
2. Be sure that the bearing bolts and the torque lock-nut is loose.
3. Set the torque wrench to 20 inch/pounds and set both sides.
4. Check the belt deflection for even tension on both sides.
5. Tighten the bearing bolts and the torque nut.

**Note: If the motor is not removed:**

6. Loosen the bearing bolts and torque nut.
7. Set the torque to 20 inch pounds (opposite the drive side).
8. Check the belt deflection (opposite the drive side)
9. Set the drive side the same
10. Tighten the bearing bolts and the torque nut.

### **BELT SPROCKET INSTALLATION / REMOVAL / ALIGNMENT**

1. For best results, remove the motor.
2. Loosen the six set screws on the reducer.
3. Remove the two bolts out of the torque arm, the motor will slide off of the shaft.

### **TAIL SPROCKET REMOVAL / INSTALLATION / ALIGNMENT**

1. Disconnect Electrical Power to the conveyor. (See electrical safety warnings in the Electrical Section of this manual before performing this step).
2. Remove the coolant tank covers that surround the conveyor
3. Remove the mounting bolts that attach the conveyor leg and the tail anchor brackets to the coolant tank.
4. Connect a chain or strap, which is properly rated for the lifting weight of the conveyor, to the lifting hooks or eyes which are located at the discharge end and the horizontal load section of the conveyor.
5. Lift the conveyor out of the coolant tank and let the conveyor tilt forward and rest on the leg.
6. Remove the drain chutes of the conveyor.
7. Remove the mounting bolts for the two brackets which are located at the tail end, underneath the conveyor
8. Remove the mounting bolts along each side of the conveyor that mounts the upper conveyor to the lower conveyor.
9. Place a support under the discharge of the lower conveyor before lifting the upper conveyor.
10. Separate the upper conveyor from the lower conveyor and sit the upper conveyor aside.
11. Loosen the bearing bolts and adjusting nuts on both sides of the lower conveyor.
12. Loosen the tension on the belt.
13. Remove the bolts out of the tail shaft.
14. Push the tail shaft toward the conveyor discharge.
15. Remove the chain off of the sprockets and move the sprockets inward.
16. Lift the shaft and the sprocket out of the conveyor.
17. Check the tail shaft and the tail sprockets for wear. If they are worn, replace them.
18. Place the sprockets on the shaft with the hubs turned outward.

19. Place the shaft in the conveyor and pull it toward the tail. Place the chain on the tail sprockets, making sure that they are in the same teeth position, in order to be timed.
20. Before replacing the bolts, add silicone to them.
21. Install the left-hand plate and start all of the mounting screws.
22. Install the right-hand plate and start all of the mounting screws.
23. Install the back-wash plumbing.
24. Tension the conveyor belt to 20 inch pounds on each side by tightening the conveyor drive adjusting screws. Check the belt deflection to insure that is the same on both sides.
25. Once the belt is properly tensioned, tighten the pillow block bearing mounting bolts while holding the nuts in place with a wrench.
26. Tighten all of the bolts on both the right-hand and left-hand side plates.
27. Install the key into the key-way in the drive shaft and slide the drive motor back into position and start the two bolts into the bracket. Push the motor as far forward as possible and tighten the mounting bolts.
28. Tighten all of the set screws on the reducer.
29. Reconnect the electrical power to the lower conveyor and test run the conveyor. See the "Electrical Section" of the manual for safety instructions and warnings.
30. If the conveyor belt makes a popping noise, check the belt and sprocket alignment. Insure that the scrapper bars are square with the belt and are tracking properly. If not, make the necessary adjustments to correct this problem.
31. After the lower conveyor has been test run for 30 minutes without any problems, stop the conveyor and check the belt tension. If necessary loosen the pillow block mounting bolts and re-tension the belt to 20 inch pounds.
32. Inspect the seal that mounts between the upper and lower conveyors. If damaged it must be replaced.
33. Put a small bead of silicone on the horizontal load section of the lower conveyor.
34. Lift the upper conveyor and properly locate it on top of the lower conveyor, aligning the mounting bolt holes.
35. Once the last two bolt holes on the horizontal load section are properly aligned begin bolting the conveyor together on both sides.

### **IDLER SPROCKET REMOVAL / INSTALLATION / ALIGNMENT**

1. Disconnect Electrical Power to the conveyor. (See electrical safety warnings in the Electrical Section of this manual before performing this step).
2. Remove the coolant tank covers that surround the conveyor
3. Remove the mounting bolts that attach the conveyor leg and the tail anchor brackets to the coolant tank.
4. Connect a chain or strap, which is properly rated for the lifting weight of the conveyor, to the lifting hooks or eyes which are located at the discharge end and the horizontal load section of the conveyor.
5. Lift the conveyor out of the coolant tank and let the conveyor tilt forward and rest on the leg.
6. Loosen the bearing bolts, torque nut, and the torque bolt to lessen the tension.
7. Remove the side plate with the plumbing mounting bracket.
8. Remove the bolts out of the side ring, then remove the ring on both sides.
9. Lift the drum teeth out of the chain, tilt the drum upward, then pull out of the other side.
10. Pull the belt over the drive sprockets and connect the master links on both sides with the clips. Insure that the clips are seated properly.
11. Loosen the bolts of the idler shaft and remove.
12. Push the shaft up, then turn and pull it out through the drum opening.
13. Check the shaft and idler sprockets for damage.
14. Place the idler sprockets on the shaft and replace them in the conveyor. Make sure the sprockets are in time, pull down, and install the bolt with the brass hub facing toward the outside. Pull the belt over the drive sprockets and connect the master links on both sides with the clips. Insure that the clips are seated properly.
15. Before installing the drum, inspect the seals, brass bearings, and screens for damage. Replace any damaged parts.
16. Insure that the clamps are rotating immediately.

17. Slide the drum in from the left side of the conveyor so that the drum sprocket teeth clear the belt. While installing the drum, tilt the drum so that the sprocket teeth clear the chain. Once in place align the sprocket teeth to insure they are in time and properly aligned with the chain on both sides.
18. Clean and grease the right-hand and left-hand side plates with grease or an equivalent type.
19. Install the left-hand plate and start all of the mounting screws.
20. Install the right-hand plate and start all of the mounting screws.
21. Install the back-wash plumbing.
22. Tension the conveyor belt to 20 inch pounds on each side by tightening the conveyor drive adjusting screws. Check the belt deflection to insure that is the same on both sides.
23. Once the belt is properly tensioned, tighten the pillow block bearing mounting bolts while holding the nuts in place with a wrench.
24. Tighten all of the bolts on both the right-hand and left-hand side plates.
25. Install the key into the key-way in the drive shaft and slide the drive motor back into position and start the two bolts into the bracket. Push the motor as far forward as possible and tighten the mounting bolts.
26. Tighten all of the set screws on the reducer.
27. Reconnect the electrical power to the lower conveyor and test run the conveyor. See the "Electrical Section" of the manual for safety instructions and warnings.
28. If the conveyor belt makes a popping noise, check the belt and sprocket alignment. Insure that the scrapper bars are square with the belt and are tracking properly. If not, make the necessary adjustments to correct this problem.
29. After the lower conveyor has been test run for 30 minutes without any problems, stop the conveyor and check the belt tension. If necessary loosen the pillow block mounting bolts and re-tension the belt to 20 inch pounds.
30. Inspect the seal that mounts between the upper and lower conveyors. If damaged it must be replaced.
31. Put a small bead of silicone on the horizontal load section of the lower conveyor.
32. Lift the upper conveyor and properly locate it on top of the lower conveyor, aligning the mounting bolt holes.
33. Once the last two bolt holes on the horizontal load section are properly aligned begin bolting the conveyor together on both sides.

### **DRUM SEAL REMOVAL AND INSTALLATION**

1. Disconnect Electrical Power to the conveyor. (See electrical safety warnings in the Electrical Section of this manual before performing this step).
2. Remove the coolant tank covers that surround the conveyor
3. Remove the mounting bolts that attach the conveyor leg and the tail anchor brackets to the coolant tank.
4. Connect a chain or strap, which is properly rated for the lifting weight of the conveyor, to the lifting hooks or eyes which are located at the discharge end and the horizontal load section of the conveyor.
5. Lift the conveyor out of the coolant tank and let the conveyor tilt forward and rest on the leg.
6. Loosen the bearing bolts, torque nut, and the torque bolt to lessen the tension.
7. Remove the side plate with the plumbing mounting bracket.
8. Remove the bolts out of the side ring, then remove the ring on both sides.
9. Lift the drum teeth out of the chain, tilt the drum upward, then pull it out of the other side.
10. Pull the belt over the drive sprockets and connect the master links on both sides with the clips. Insure that the clips are seated properly.
11. Inspect the brass and the rings on the drum for wear. Check the drum screen for holes. Check the seal spacer for damage.
12. If the drum seals are damaged, remove and replace them with new ones.
13. Clean the rings and any surface area that the seal will be in contact with.
14. Lubricate with specified grease.
15. Before installing the drum, inspect the seals, brass bearings, and screens for damage. Replace any damaged parts.
16. Insure that the clamps are rotating immediately.
17. Slide the drum in from the left side of the conveyor so that the drum sprocket teeth clear the belt. While installing the drum, tilt the drum so that the sprocket teeth clear the chain. Once in place align the sprocket teeth to insure they are in time and properly aligned with the chain on both sides.

18. Clean and grease the right-hand and left-hand side plates with grease or an equivalent type.
19. Install the left-hand plate and start all of the mounting screws.
20. Install the right-hand plate and start all of the mounting screws.
21. Install the back-wash plumbing.
22. Tension the conveyor belt to 20 inch pounds on each side by tightening the conveyor drive adjusting screws. Check the belt deflection to insure that is the same on both sides.
23. Once the belt is properly tensioned, tighten the pillow block bearing mounting bolts while holding the nuts in place with a wrench.
24. Tighten all of the bolts on both the right-hand and left-hand side plates.
25. Install the key into the key-way in the drive shaft and slide the drive motor back into position and start the two bolts into the bracket. Push the motor as far forward as possible and tighten the mounting bolts.
26. Tighten all of the set screws on the reducer.
27. Reconnect the electrical power to the lower conveyor and test run the conveyor. See the "Electrical Section" of the manual for safety instructions and warnings.
28. If the conveyor belt makes a popping noise, check the belt and sprocket alignment. Insure that the scrapper bars are square with the belt and are tracking properly. If not, make the necessary adjustments to correct this problem.
29. After the lower conveyor has been test run for 30 minutes without any problems, stop the conveyor and check the belt tension. If necessary loosen the pillow block mounting bolts and re-tension the belt to 20 inch pounds.
30. Inspect the seal that mounts between the upper and lower conveyors. If damaged it must be replaced.
31. Put a small bead of silicone on the horizontal load section of the lower conveyor.
32. Lift the upper conveyor and properly locate it on top of the lower conveyor, aligning the mounting bolt holes.
33. Once the last two bolt holes on the horizontal load section are properly aligned begin bolting the conveyor together on both sides.

#### **BACK-WASH FILTER REMOVAL / CLEANING / INSTALLATION**

1. Locate the incline filter.
2. Turn the back-wash coolant system off.
3. Remove the bolt that secures the canister to the housing.
4. Remove the mesh filter element.
5. Clean the filter screen and canister.
6. Inspect the seal for damage. If damaged, replace.
7. Assemble the filter.
8. Turn the back-wash coolant system on, check for leakage.

#### **BACK-WASH DRUM NOZZLE REMOVAL / CLEANING / INSTALLATION**

1. Remove the two (2) 7/16 nuts from the plumbing bracket.
2. Slide the manifold assembly out.
3. Remove the nozzles and check for clogging.

## REMOVAL AND INSTALLATION OF DRUM SCREEN

1. Disconnect Electrical Power to the conveyor. (See electrical safety warnings in the Electrical Section of this manual before performing this step).
2. Remove the coolant tank covers that surround the conveyor.
3. Lift the conveyor out of the coolant tank and let the conveyor tilt forward and rest on the leg.
4. Connect a chain or strap, which is properly rated for the lifting weight of the conveyor, to the lifting hooks or eyes which are located at the discharge end and the horizontal load section of the conveyor.
5. Lift the conveyor out of the coolant tank and let the conveyor tilt forward and rest on the leg.
6. Loosen the pillow block bearing mounting bolts and nuts and take the tension off of the belt by moving the drive shaft assembly toward the tail of the conveyor.
7. Remove the side plate along with the plumbing mounting bracket.
8. Remove the bolts out of the side ring and remove the side ring.
9. Remove the bolts from the side ring on the other side and remove the side ring.
10. Lift the drum teeth above the belt chain by tilting the drum upward and pulling it out of the side of the conveyor frame.
11. Before installing the drum, inspect the seals, brass bearings, and screens for damage. Replace any damaged parts.
12. Insure that the clamps are rotating immediately.
13. Slide the drum in from the left side of the conveyor so that the drum sprocket teeth clear the belt. While installing the drum, tilt the drum so that the sprocket teeth clear the chain. Once in place align the sprocket teeth to insure they are in time and properly aligned with the chain on both sides.
14. Clean and grease the right-hand and left-hand side plates with grease.
15. Install the left-hand plate and start all of the mounting screws.
16. Install the right-hand plate and start all of the mounting screws.
17. Install the back-wash plumbing.
18. Tension the conveyor belt to 20 inch pounds on each side by tightening the conveyor drive adjusting screws. Check the belt deflection to insure that is the same on both sides.
19. Once the belt is properly tensioned, tighten the pillow block bearing mounting bolts while holding the nuts in place with a wrench.
20. Tighten all of the bolts on both the right-hand and left-hand side plates.
21. Install the key into the keyway in the drive shaft and slide the drive motor back into position and start the two bolts into the bracket. Push the motor as far forward as possible and tighten the mounting bolts.
22. Tighten all of the set screws on the reducer.
23. Reconnect the electrical power to the lower conveyor and test run the conveyor. See the "Electrical Section" of the manual for safety instructions and warnings.
24. If the conveyor belt makes a popping noise, check the belt and sprocket alignment. Insure that the scrapper bars are square with the belt and are tracking properly. If not, make the necessary adjustments to correct this problem.
25. After the lower conveyor has been test run for 30 minutes without any problems, stop the conveyor and check the belt tension. If necessary loosen the pillow block mounting bolts and retension the belt to 20 inch pounds. (Follow steps 30 – 31).

## SEPARATING THE UPPER AND LOWER CONVEYORS

In the event that the upper and lower conveyors must be separated to perform maintenance on the lower conveyor, following procedure must be performed.

1. Disconnect power to conveyor system and lock out the machine according to lockout/tagout procedures.
2. Disconnect any power cables that will interfere with the removal of the conveyor(s). For example, the drive motor cables, back-wash pump cable, and conveyor cable to the machine tool. Note that the back-wash pump cable can be unplugged at the conveyor control and normally the conveyor cable to the machine tool has a quick disconnect type plug for easy disconnection. Insure that only authorized and trained electrical maintenance personnel perform this step.
3. Remove any tank lids that restrict access to the flange on the conveyor horizontal load sections where they are bolted together.
4. Support the upper conveyor discharge end with a crane or other lifting device using the lifting lugs attached to each side of the frame.
5. Remove the bolts attaching the upper conveyor bracket to the lower conveyor bracket. These brackets are located under the discharge end of the upper conveyor and on top of the discharge of the lower conveyor (see the diagram below).
6. Remove the bolts securing the upper conveyor to the lower conveyor which are located in the horizontal load section (as shown below).
7. With safety straps attached to the lifting hooks, the upper conveyor can now be removed from the lower conveyor.
8. If the lower conveyor must be removed from the coolant tank, properly secure the conveyor with a crane or other lifting device using the lifting lugs provided on the conveyor. Once the conveyor is properly supported with a lifting device, remove the bolts securing the leg to the coolant tank support bracket. Also, remove any mounting bolts inside the coolant tank that secure the lower conveyor to the coolant tank.
9. Once these steps have been completed the lower conveyor can be lifted from the coolant tank.

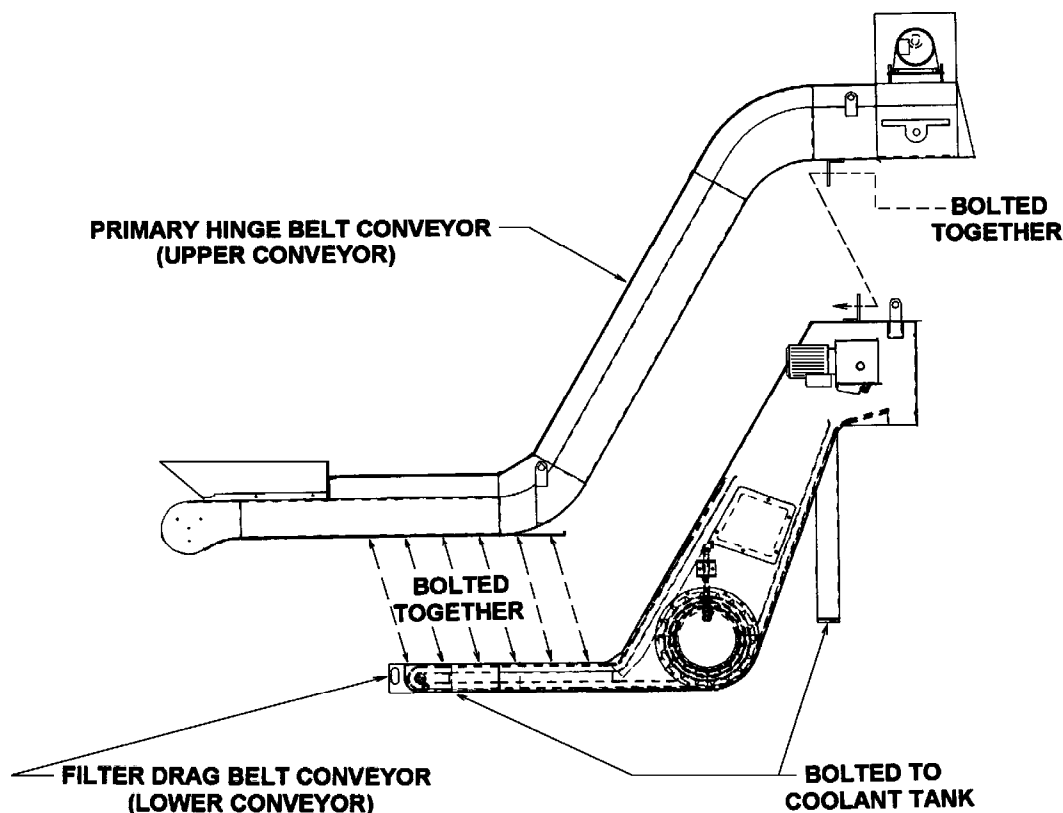



# CONVEYOR TERMINOLOGY

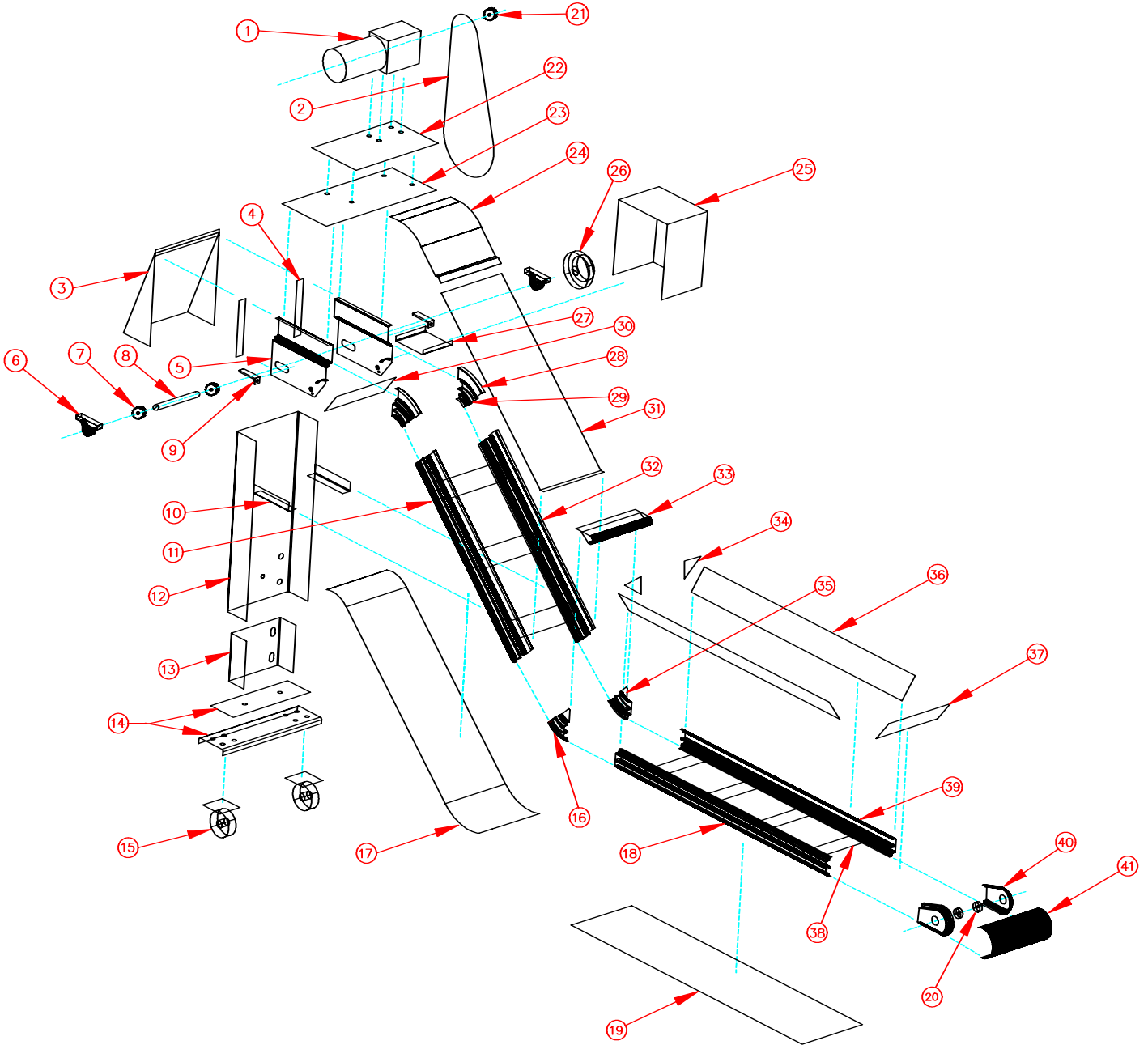

## CONVEYOR TERMINOLOGY (CONTINUED)

- 1 GEAR MOTOR
- 2 DRIVE CHAIN
- 3 HINGED DISCHARGE FILLER
- 4 DISCHARGE PLATE
- 5 DISCHARGE PLATE
- 6 BEARING (2)
- 7 DRIVE SPROCKET (2)
- 8 DRIVE SHAFT
- 9 BEARING MOUNT (2)
- 10 LEG BRACE LH
- 11 SIDE PLATE INCLINE LH
- 12 LEG
- 13 LEG EXTENSION
- 14 FOOT PLATE OR CASTER PLATE (OPTIONAL)
- 15 CASTER (2)
- 16 TOP COVER SUPPORT LOWER CURVE (2)
- 17 BOTTOM COVER INCLINE
- 18 SIDE PLATE LOAD LH
- 19 BOTTOM COVER LOAD
- 20 TAIL DISC (2)
- 21 HUB SPROCKET
- 22 MOTOR ADAPTER PLATE
- 23 MOTOR MOUNTING PLATE
- 24 TOP COVER UPPER CURVE
- 25 DRIVE COVER
- 26 DRIVE COVER
- 27 CLUTCH ASSEMBLY
- 28 FLANGE (2)
- 29 TOP COVER SUPPORT UPPER CURVE (2)
- 30 FRAME SUPPORT DISCHARGE
- 31 TOP COVER INCLINE
- 32 SIDE PLATE INCLINE RH
- 33 CHIP SUPPRESSOR
- 34 GUSSET @ CHIP SUPPRESSOR (2)
- 35 LOWER CURVE (2)
- 36 LOAD BAFFLE RH
- 37 TAIL BAFFLE
- 38 CROSS TIE BAR
- 39 SIDE PLATE LOAD RH
- 40 SIDE PLATE TAIL (2)
- 41 TAIL END COVER

## MICROFINE 2 TROUBLE SHOOTING GUIDE

The following chart will show some problems, their probable causes and possible solutions.

PROBLEM	POSSIBLE CAUSE	POSSIBLE SOLUTION
(1) Fines build-up on drum filter screens:	(a) Drum filter/back-wash pump not running:	Check switch position at control – insure filter/back-wash is turned to "On" position.
	(b) Drum filter/back-wash pump running backward:	Check lower conveyor belt direction for proper travel rotation.
	(c) Drum filter/back-wash pump failure:	See #4 and #5.
	(d) Back-wash spray nozzles are clogged.	Remove back-wash spray nozzles and clean or replace.
	(e) The spray pattern of the back-wash nozzles are not cleaning the entire width of the drum filter.	The spray nozzle(s) are not oriented properly on the spray manifold. The slit in the nozzle must be parallel with the centerline of the filter drum.
	(f) The back-wash in-line filter is clogged.	Remove in-line back-wash filter and clean.
	(g) The ball valve that regulates the coolant flow to the back-wash manifold is closed off too much.	Open the ball valve to allow more coolant flow and pressure to clean the drum filter screen.
(2) Low coolant flow or over-flow of load section baffles:	(a) Plugged drum filter screens.	See #1 above.
	(b) Drain boxes or drain slots from upper conveyor are plugged.	Reduce the static coolant level to below the exposed upper conveyor belt.
	(c) The coolant level in the tank is too high.	Remove the drain boxes and clean. If necessary remove belt from upper conveyor and clean drain slots in the bottom cover.
	(d) Coolant foam build-up.	Change the coolant type to a less foam producing coolant or use a de-foaming agent recommended by the coolant manufacturer.
(3) Deteriorating fines removal efficiency:	(a) Damaged or worn drum seals, torn or loosened screens	Remove and replace worn or damaged parts.
	(b) Torn or damaged drum filter screen.	Remove and replace worn or damaged filter screen.
(4) Drum rotation failure:	(a) Overload relay in motor control circuit has tripped out for lower conveyor drive.	Reset overload relay.
	(b) Failed gearmotor for lower conveyor.	Replace gearmotor for lower conveyor.
	(c) Excessive motor wear or burn-out	Replace motor.
	(d) Sheared shaft key at drive motor sprocket or drum drive sprocket	Replace failed parts AFTER determining cause of failure; maybe caused by filter drum lock-up.
	(e) Worn-out drive sprockets, excessively loose or broken drive chain	Replace worn or broken parts.
	(f) Failed drum sprocket(s).	Replace drum sprocket(s).

<b>PROBLEM</b>	<b>POSSIBLE CAUSE</b>	<b>POSSIBLE SOLUTION</b>
(5) Back-wash system failure:	(a) Blown fuse or overload relay has tripped in control circuit	Replace fuse or reset overload relay.
	(b) Clogged back-wash in-line strainer	Clean the back-wash in-line strainer.
	(c) Plugged spray nozzles	Remove back-wash spray nozzles and clean or replace.
	(d) Failed pump motor or pump impeller	Replace pump or damaged pump part(s).
	(e) The ball valve, which regulates the coolant flow to the back-wash manifold, is closed off too much.	Open the ball valve to allow more coolant flow and pressure to clean the drum filter screen.
(6) Noisy drum rotation (squeak or metallic grating sound):	(a) Excessively worn drum bearings.	Replace drum bearings.
(7) Belt is not moving.	(a) Overload relay in drive motor control circuit has tripped out.	Reset overload relay.
	(b) Overload relay is undersized for the amp. draw of the motor. (See electrical schematic or read the full amp. draw ratings on the motor to determine the correct overload relay or fuse setting for the conveyor. Note: overload setting must never exceed 150% of the rated full amp. load of the motor(s). Recommended 110-120%.	Replace the overload relay with the correct size for the conveyor drive motor.
	(c) Conveyor belt is broken.	Repair the damaged section or replace the belt.
	(d) Sheared shaft key at drive motor sprocket	Replace failed parts AFTER determining cause of failure;
	(e) Worn-out drive sprockets, excessively loose or broken drive chain	Replace worn or broken parts.
	(f) Motor drive chain is either broken or chain tension is too loose.	Repair chain or properly tension chain.
(8) Belt is pulsating or surging:	(a) Belt tension is either too tight or too loose.	Properly tension belt.
(9) Excessive wear of belt components:	(a) Belt tension is either too tight or too loose.	Properly tension belt.
	(b) Improper alignment of drive sprockets or tail sprocket.	Properly align sprockets.
	(c) Conveyor is not level or square.	Properly level conveyor.
(10) Excessive wear of the conveyor frame:	(a) Conveyor is not level or square.	Properly level conveyor.
	(b) Belt tension is either too tight or too loose.	Properly tension belt.
(11) No chips are being disposed by the conveyor.	(a) The belt is running backwards.	Reverse the motor leads so that the belt is running in the correct direction.
	(b) The belt is not moving. See section # 7 above.	Repair or replace the belt.

PROBLEM	POSSIBLE CAUSE	POSSIBLE SOLUTION
(12) The belt is jamming.	(a) Cotter pin(s) have sheared and/or belt roller(s) have fallen off of the belt assembly.	Replace missing cotter pins and/or rollers.
	(b) The master link on the belt of the lower conveyor has separated.	Replace the master link assembly.
	(c) The scrapper bar(s) has broken, fallen off the belt or been damaged in the lower conveyor.	Reattach or replace the scrapper bar(s) if it is damaged. (Note never reuse the nylock mounting nuts. Once they are loosened, they must be replaced to maintain their effectiveness.
	(d) The scrapper bar(s) are not properly aligned with the belt.	Realign the scrapper bar(s) with the belt. (Note never reuse the nylock mounting nuts. Once they are loosened, they must be replaced to maintain their effectiveness.
	(e) An object, such as a tool, part, etc. has fallen down into the conveyor and become lodged.	Remove the foreign object from the conveyor.

## MICROFINE 2 MAINTENANCE SCHEDULE

The following chart shows a suggested maintenance schedule for the conveyor to insure proper operation and longevity.

Time Frame	Procedure	Problem	Resolution
Daily	Check coolant level at tank sight gauge.	Too low.	Fill until level reaches full mark on coolant tank sight gauge.
Daily	Check back-wash strainer gauges located on the strainer.	Gauges show a pressure differential greater than 5 psi.	Remove strainer and clean out basket
Daily	Check coolant for foaming in tank and through viewing windows.	Coolant foaming is blinding back-wash filter screen.	<ol style="list-style-type: none"> <li>1. Check for excessive back-wash pressure.</li> <li>2. Check for improper coolant concentration.</li> <li>3. Add coolant defoamer.</li> </ol>
Weekly	Check back-wash filter screen.	Screen is blinded by chips or foaming.	<ol style="list-style-type: none"> <li>1. If screen is blinded by chips, check to make sure back-wash pressure is adequate: coolant level, clogged strainer or pump problems are most likely cause.</li> <li>2. If foaming is the problem, see resolution above.</li> </ol>
Weekly	Check lower conveyor chip shelf.	Too many chips stuck to shelf.	Brush off shelf <b>with the conveyor turned off.</b>
Every 3 months	Check upper conveyor belt tension.	Belt is too loose (slack) or too tight.	Adjust belt tension per the procedure in your Service Manual. <b>Make sure all safety procedures are followed.</b>
Every 3 months	Check lower conveyor belt tension.	Belt is too loose (slack) or too tight.	Adjust belt tension per the procedure in your Service Manual. <b>Make sure all safety procedures are followed.</b>
Every 6 months	Check upper conveyor clutch adjustment.	Clutch is too tight.	Clutch is preset at the factory. Any clutch adjustment should be made to factory specification. Contact LNS Service Dept.

## STANDARD AND HEAVY DUTY BELT

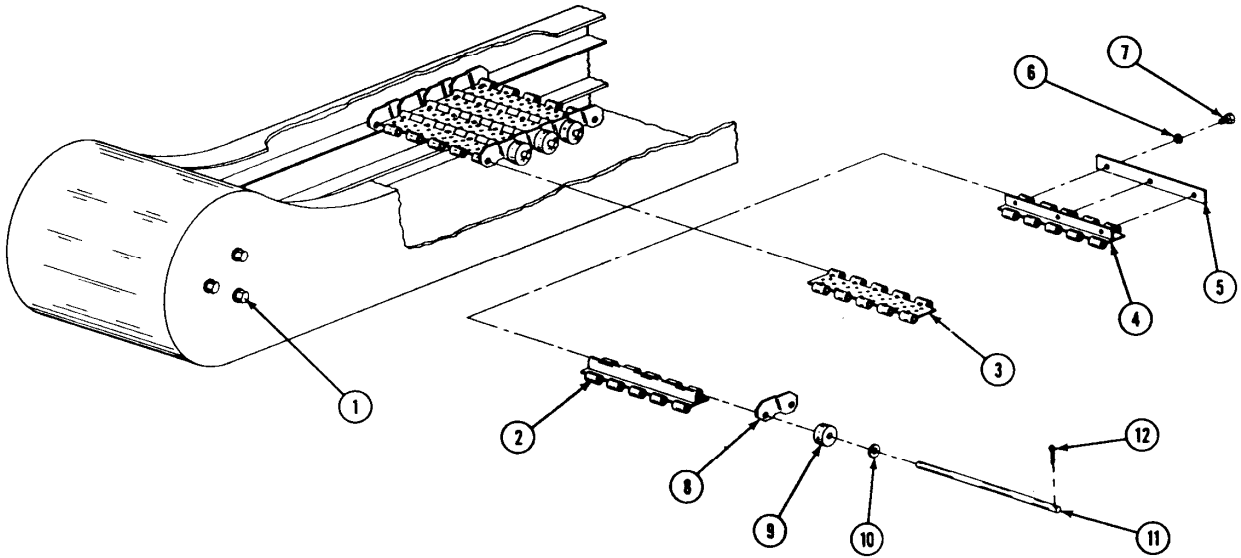

**NOTE: Your conveyor may not appear exactly as shown here. However, the individual parts can be identified from these parts plates. (Follow ordering instructions.)**

ITEM NO.	CATALOG NO.	PART NAME	ITEM NO.	CATALOG NO.	PART NAME
1	75B-3	Hex Head Screw	7	75B-11	Hex Head Screw
	75B-4	Lock washer	8	75B-90	Side Wing (Right Hand), (Shown)
	75B-5	Idler (Tail Disc)		75B-91	Side Wing (Left Hand)
2	75B-6	Hinge Plate w/ Cleat	9	75B-14	Roller
3	75B-7	Hinge Plate	10	75B-108	Washer
4	75B-8	Hinge Plate w/ Wiper Cleat	11	75B-16	Link Pin
5	75B-9	Wiper	12	75B-17	Cotter Pin
6	75B-10	Washer			

## SUPER HEAVY DUTY BELT

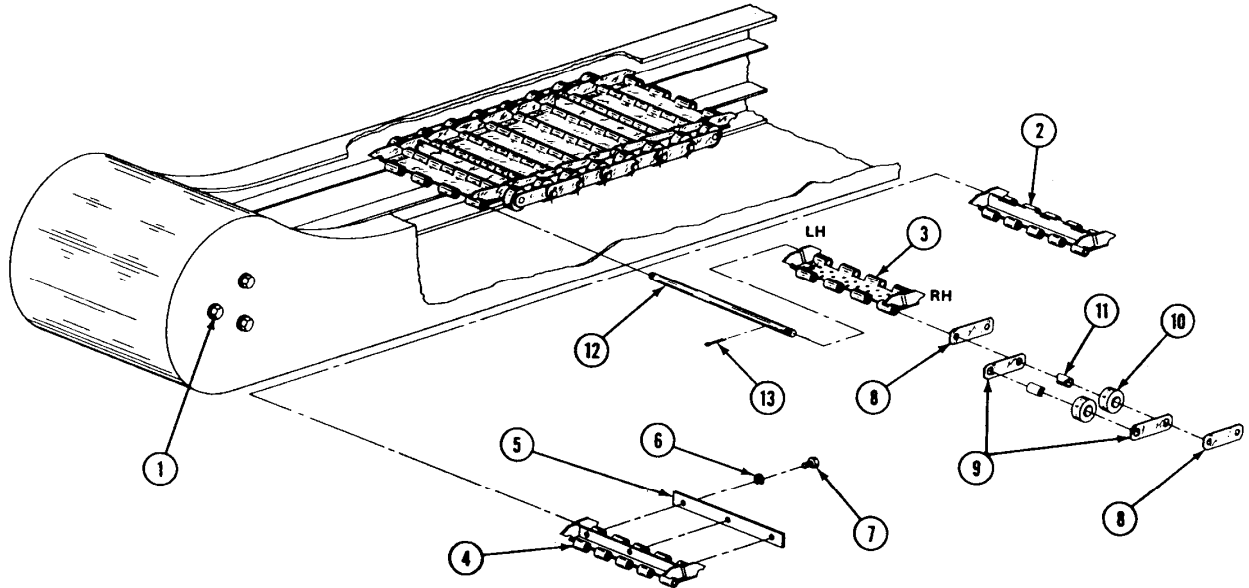

**NOTE:** Your conveyor may not appear exactly as shown here. However, the individual parts can be identified from these parts plates. (Follow ordering instructions.)

ITEM NO.	CATALOG NO.	PART NAME	ITEM NO.	CATALOG NO.	PART NAME	
1	75B-3	Hex Head Screw	6	75B-10	Washer	
	75B-4	Lock washer		7	75B-11	Hex Head Screw
	75B-5	Idler (Tail Disc)		8	75B-12	Link Plate
2	75B-6	Hinge Plate w/ Cleat	75B-80		Roller Link Assembly	
	3	75B-7	Hinge Plate Assembly	9	*75B-13	Link Plate Roller Assembly
		*75B-71	Side Wing – Right Hand	10	*75B-14	Roller
*75B-72	Side Wing – Left Hand	11	75B-15		Split Bushing	
4	75B-8	Hinge Plate w/ Wiper Cleat	12	75B-16	Link Pin	
						5

\* Part of the Above Assembly



## TOP MOUNT PARALLEL GEAR MOTOR

ITEM NO.	CATALOG NO.	PART NAME	ITEM NO.	CATALOG NO.	PART NAME
1	75B-26	Drive cover	19	75B-77	Key, 1/4" x 1 1/2"
2	75B-60	Washer, flat, 1/2"	20	75B-40	Drive chain
3	75B-61	Washer, lock, 1/2"	21	75B-42	Sprocket
4	75B-29	Bearing safety cover	22	75B-43	Setscrew, .313-18 x .375
5	75B-30	Hex nut, .500-13	23	75B-44	Key, 1/4" x 1 1/2"
6	75B-31	Bearing adjusting screw, .500-13 x 4	24	75B-45	Drive shaft
7	75B-32	Top cover – incline	25	75B-55	Hex head cap screw, .500-13 x 2.00
8	75B-32A	Top cover – upper curve	26	75B-56	Pillow block bearing
9	75B-33	Button head cap screw, .250-20 x .50	27	75B-60	Washer, flat, 1/2"
10	75B-73	Hex nut, .375-16	28	75B-61	Washer, lock, 1/2"
11	75B-34	Flat washer, 3/8"	29	*75A-29	Clutch assembly
12	75B-35	Hex nut, .375-16	30	*75A-30	Spring
13	75B-36	Washer, lock, 3/8"	31	*75A-31	Hex nut, .500-13/.750-16
14	75B-37	Hex head cap screw, .375-16 x 1.25"	32	*75A-32	Stud
15	75B-74	Motor support stud	33	*75A-33	Thrust bearing
16	75B-75	Motor adapter plate	34	*75A-34	Trust washer
17	75B-76	Parallel gearmotor (specify voltage)	35	*75A-35	Clutch sprocket
18	75B-38	Setscrew, .375-16 x .375"	36	*75A-36	Threaded insert
	75B-39	Motor sprocket	37	*75A-50	Steel ball
			38	75B-80	Clutch body
					Motor mounting plate

\* part of the above assembly.

## TOP MOUNT PARALLEL GEAR MOTOR

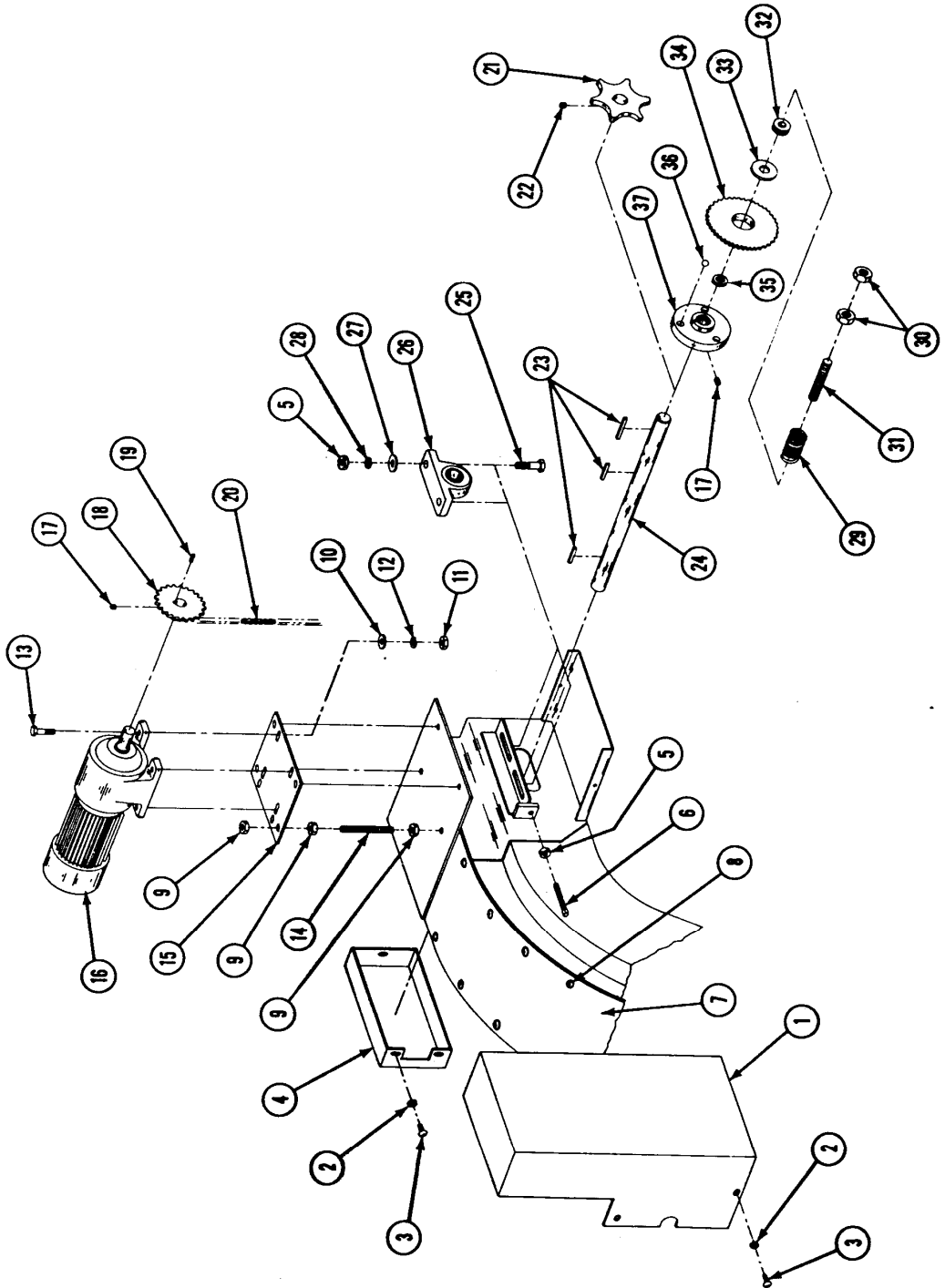

**NOTE:** Your conveyor may not appear exactly as shown here. However, the individual parts can be identified from these parts plates. (Follow ordering instructions.)

## LOWER CONVEYOR – FILTER DRUM AND BACK-WASH PARTS

ITEM NO.	CATALOG NO.	PART NAME	ITEM NO.	CATALOG NO.	PART NAME
1	86A-1	Drain Cover	13	65A-9	Pipe Nipple, 1/2 NPT X 8.0"
2	86A-2	Access Cover Weldment	14	65A-4	Close Nipple, 1/2 NPT
3	86A-3	Bronze Bearing	15	65A-2	Pressure Gauge
4	65A-103	V-Ring Seal, Viton	16	65A-6	In-line Strainer
5	65A-106	Hose Clamp	17	65A-1	1/2" Hose Barbed Nipple
6	65A-111	Filter Mesh Screen	18	86A-7	Drain Cover, Back-wash Side
7	86A-4	Drain Box Cover	19	86A-8	Window
8	86-A-5	Gasket	20	65A-107	Durm Housing
9	86A-6	Cap	21	86A-9	Ball Valve
10	65A-19	Spray Nozzle	22	86A-10	Elbow 45°, 1/2 NPT
11	65A-18	Manifold Tube	23	65A-105	Drum Spacer
12	65A-12	Elbow 90°, 1/2 NPT			

# LOWER CONVEYOR – FILTER DRUM AND BACK-WASH PARTS

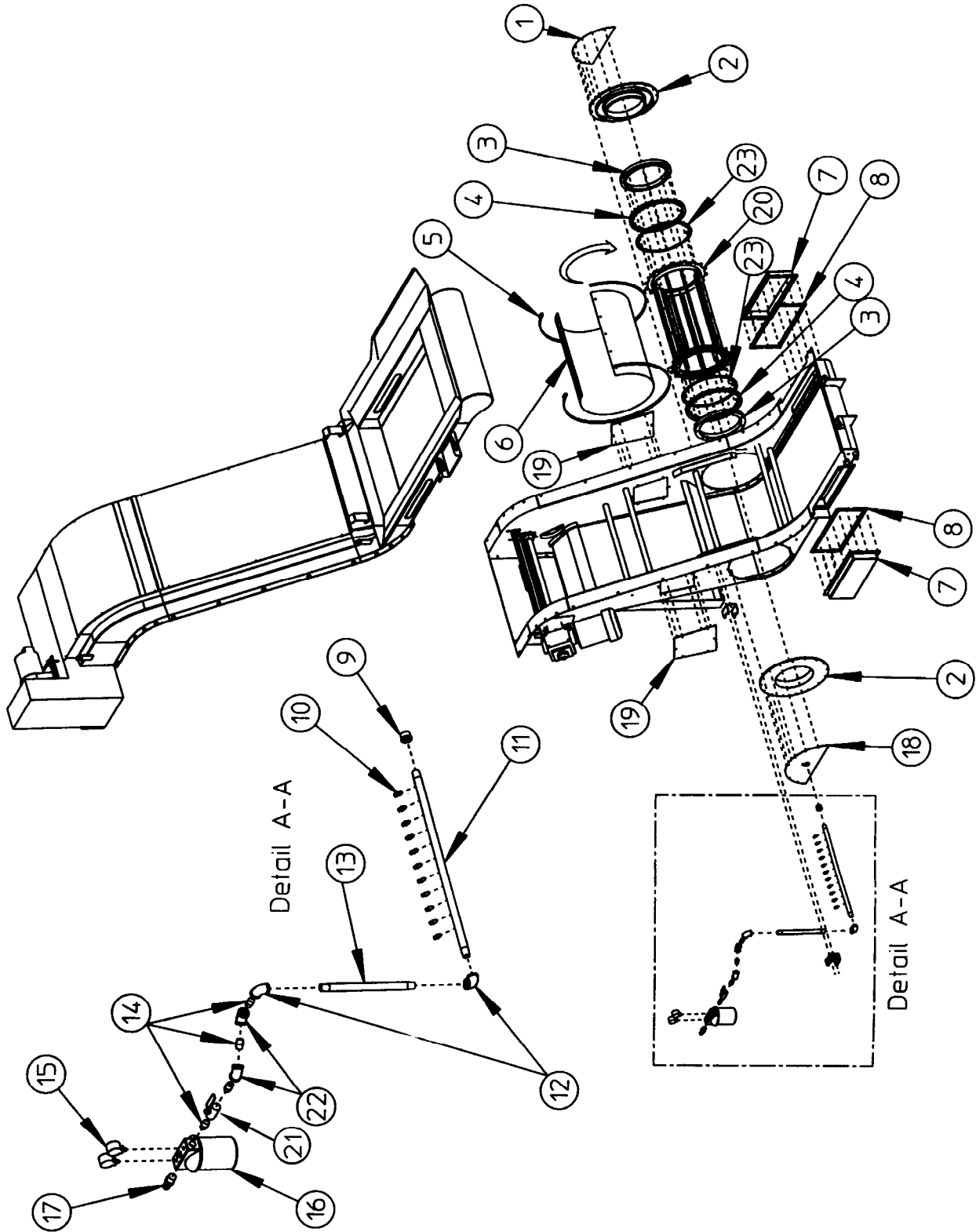

## LOWER CONVEYOR – FILTER DRUM ASSEMBLY

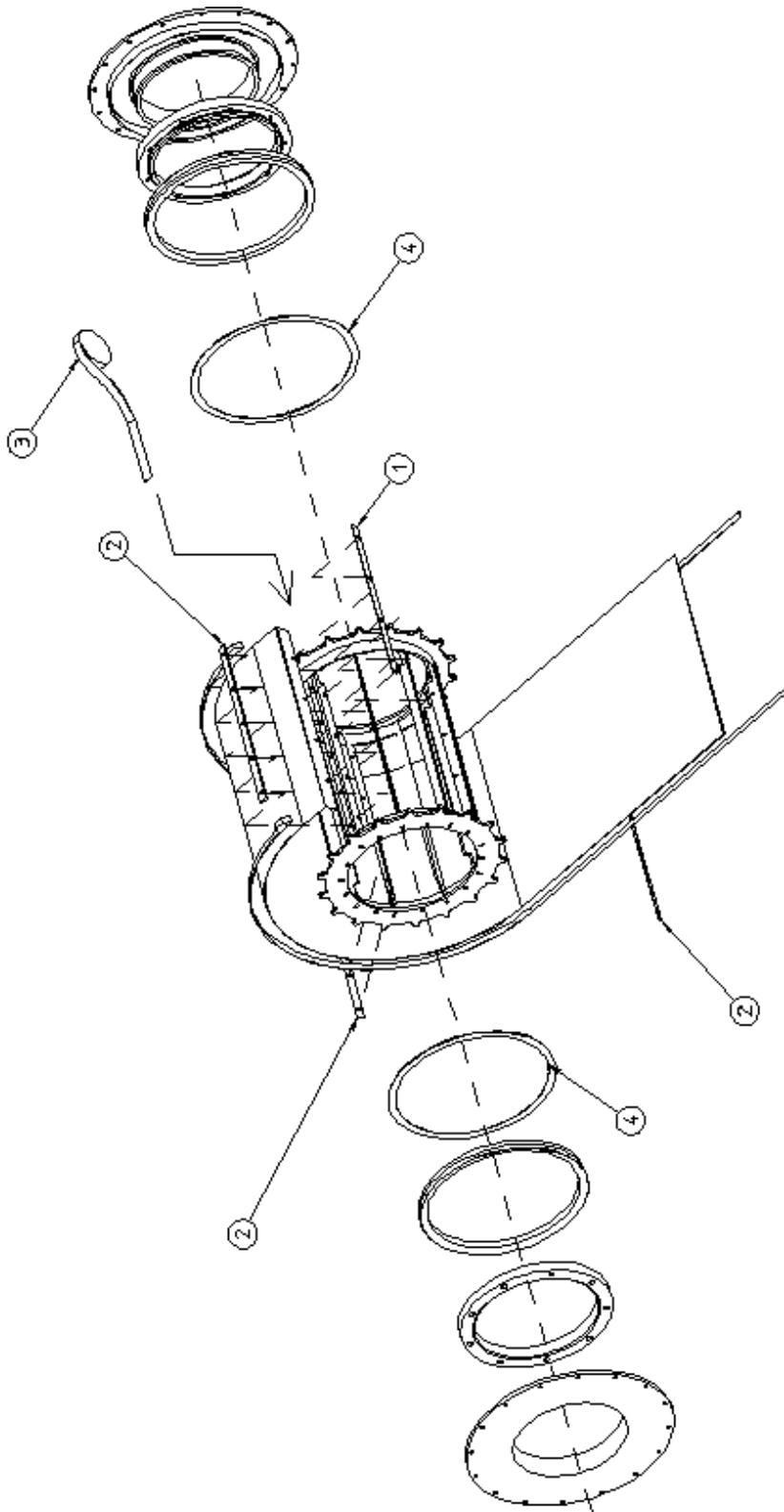

ITEM NO.	CATALOG NO.	PART NAME	ITEM NO.	CATALOG NO.	PART NAME
1	86A-16	Filter Screen Start Clamp	3	86A-17	Flat Roll Seal, Viton
2	86A-11	Filter Screen Clamping Bar	4	65A-105	Drum Spacer

## LOWER CONVEYOR – TAIL & IDLER SHAFTS/SPROCKETS

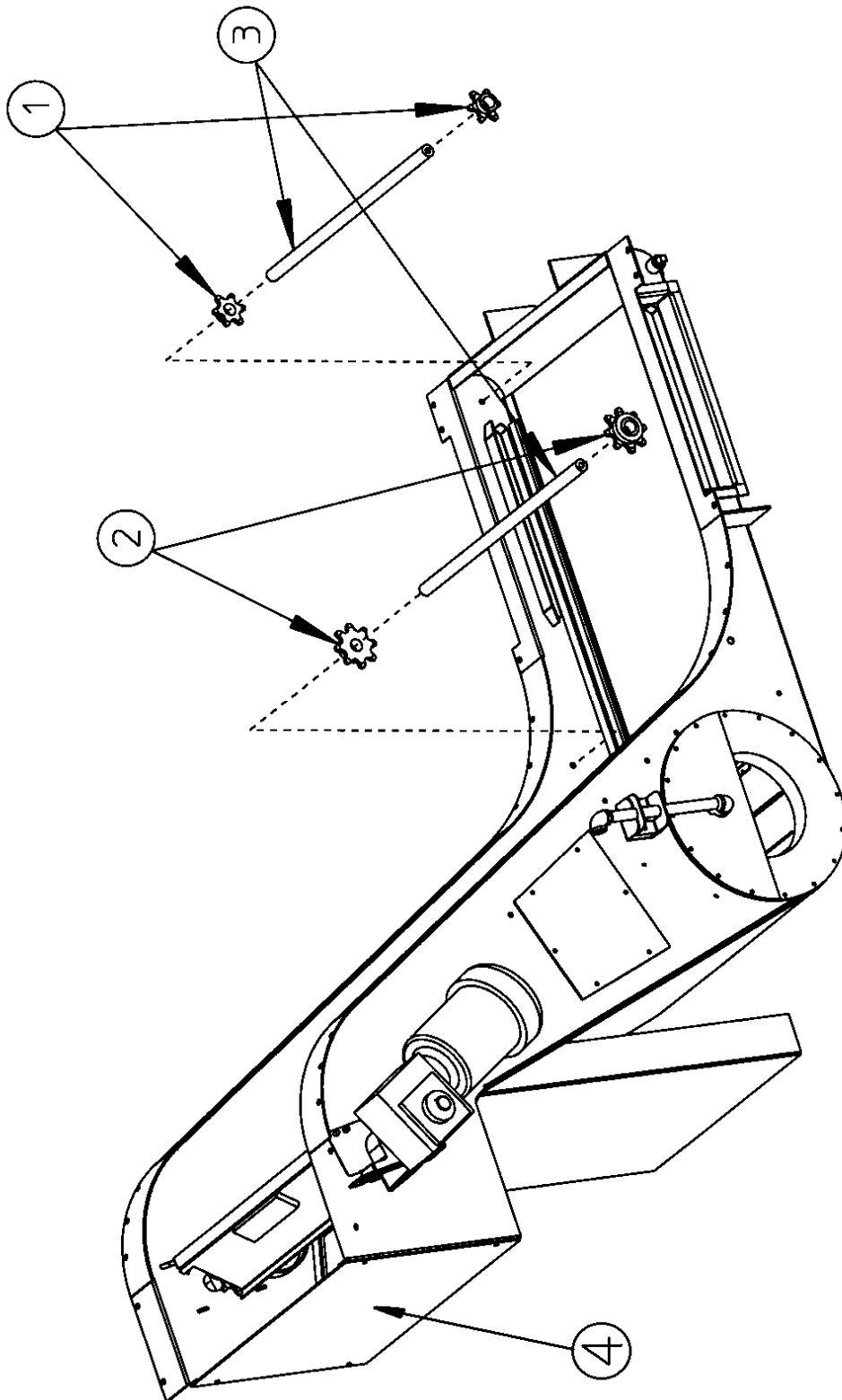

ITEM NO.	CATALOG NO.	PART NAME	ITEM NO.	CATALOG NO.	PART NAME
1	75B-5A	Idler (Tail Disc)	3	85A-21	Tail Shaft Discharge Cover
1A	85A-19	Tail Sprocket	4	89A-2	
2	86A-11	Idler Sprocket			

## LOWER CONVEYOR – DISCHARGE & DRIVE

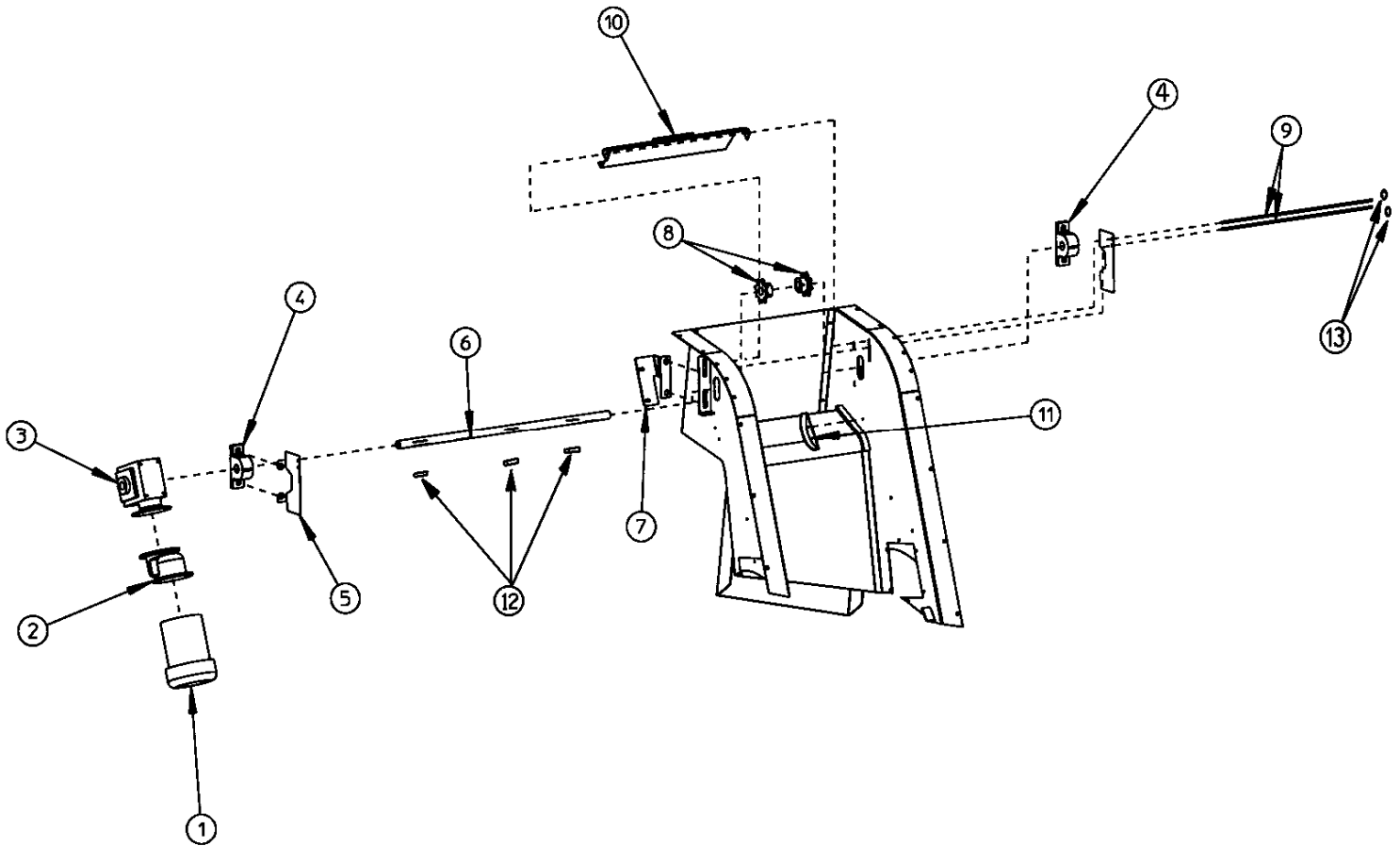

NOTE: Your conveyor may not appear exactly as shown here. However, the individual parts can be identified from these parts plates. (Follow ordering instructions.)

ITEM NO.	CATALOG NO.	PART NAME	ITEM NO.	CATALOG NO.	PART NAME
1A	*86A-20	Gearmotor	7	86A-21	Torque Arm
1	*86A-12	Motor	8	75B-42	Sprockets, Drive
2	*86A-13	Speed Reducer	9	85A-112	Bar, Cleat Scraper Mounting
3	*86A-14	Gear Reducer	10	85A-113	Cleat Scraper Weldment
4	75B-56	Bearing, Pillow Block	11	86A-15	Guide
5	85A-118	Cover, Slot Guard	12	75B-44	Keys, ¼ X 1 ½
6	75B-45	Drive Shaft	13	85A-111	Pushnut Fastener (9863-1039)

\* Note: The conveyor will either have catalog no. 86A-20 or catalog nos. 86A-12, 86A-13 and 86A-14 depending upon the serial number.

## LOWER CONVEYOR – SCRAPER BELT PARTS

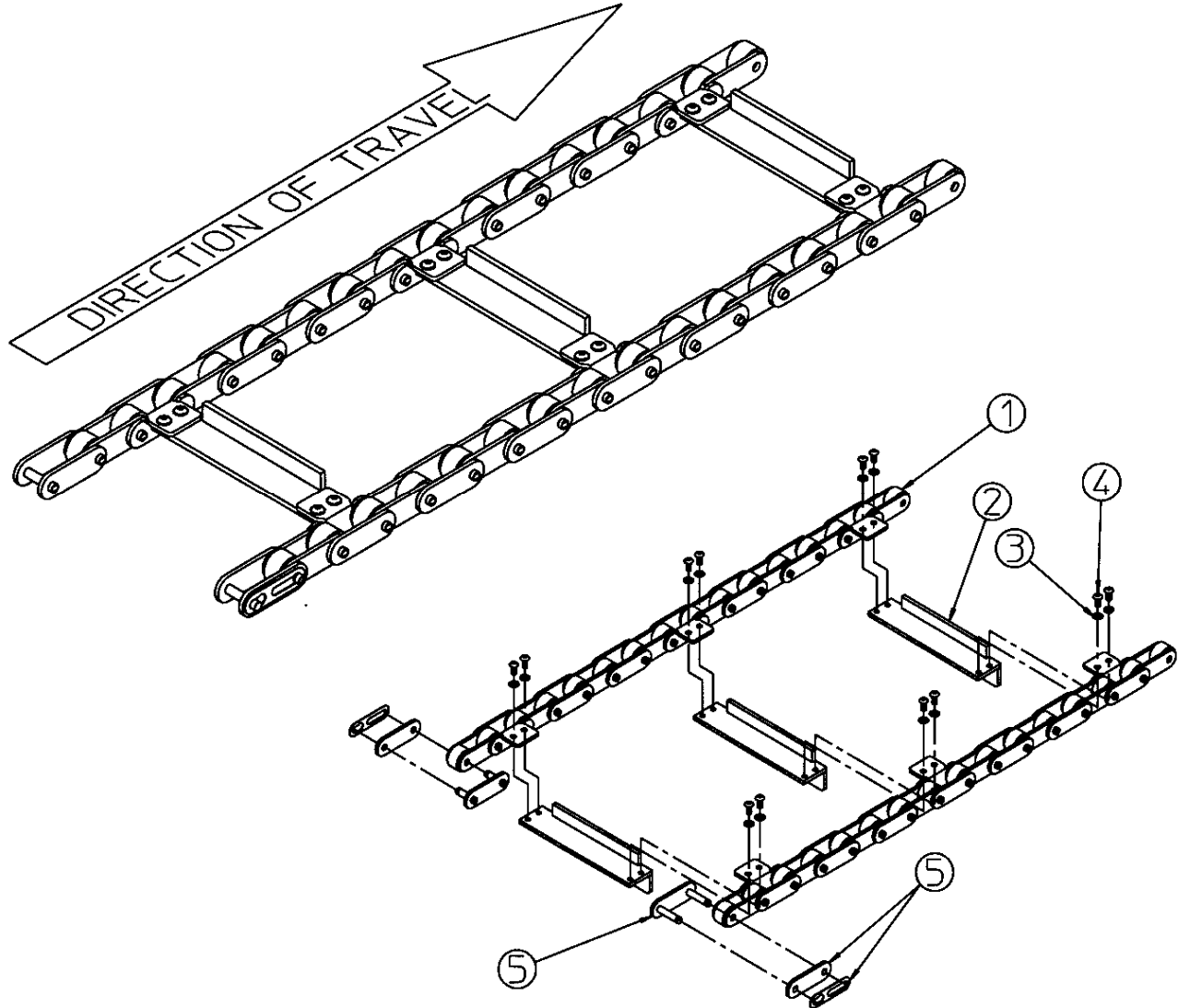

ITEM NO.	CATALOG NO.	PART NAME	ITEM NO.	CATALOG NO.	PART NAME
1	85A-7	Belt Chain with Attachments	4	85A-18	Bolt, #10-24 Shoulder (8825-1100)
2	85A-9	Formed Cleat Weldment	5	85A-8	Connecting Link
3	85A-11	Nut, Hex Nylock #10-24 (8852-1605)			



## MICROFINE® 2 BACK-WASH PUMP ASSEMBLY PARTS LIST

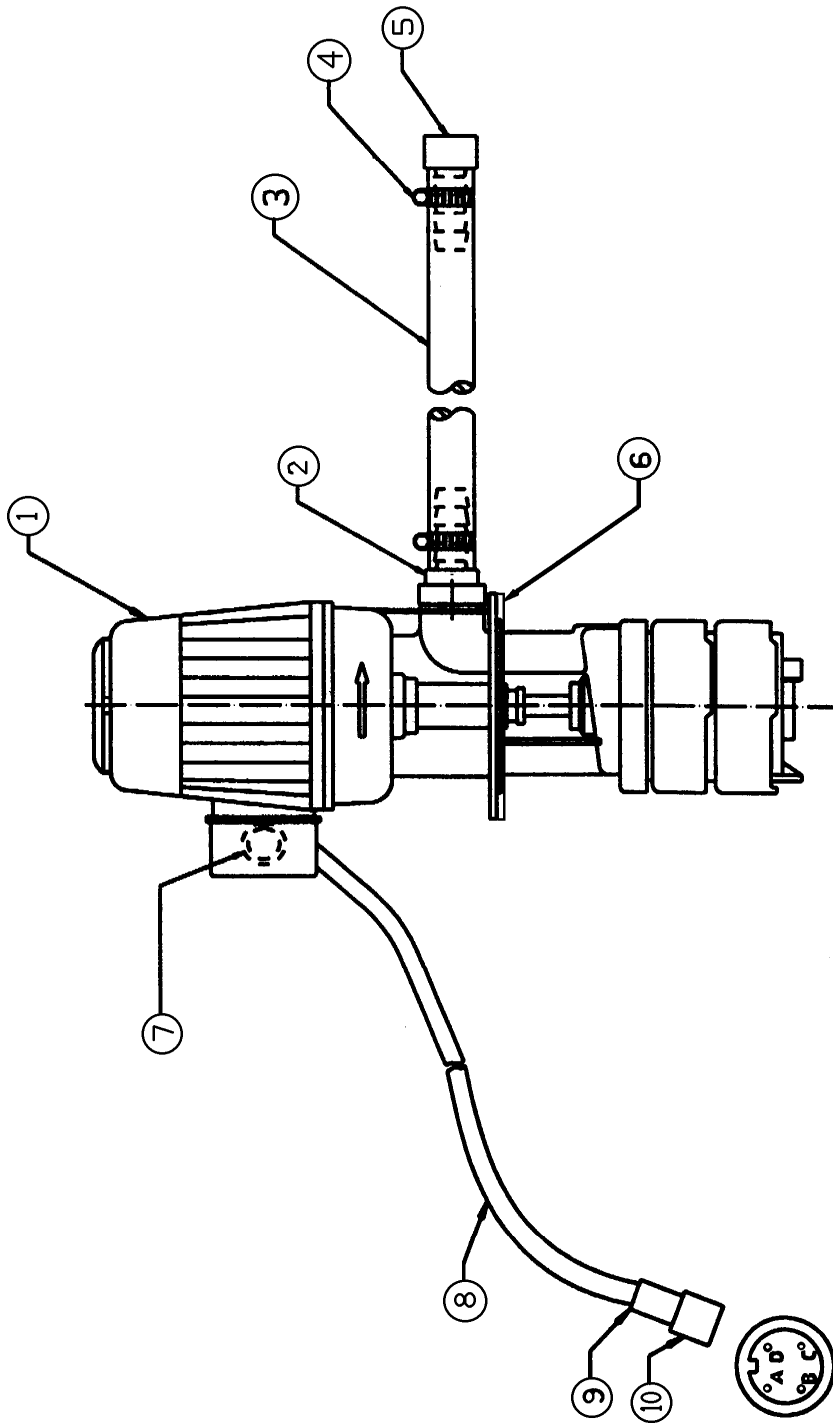

ITEM NO.	CATALOG NO.	PART NAME	ITEM NO.	CATALOG NO.	PART NAME
1	65C-35	Pump, Electric Immersion	6	65C-40	Gasket, Pump (6599-1526)
2	65C-36	Hose Barb Fitting (9874-1197)	7	65C-41	Cord Grip Connector (9900-1080)
3	65C-37	Clear Vinyl Hose (7190-2250)	8	65C-42	Flexible Cable (3189-0406)
4	65C-38	Hose Clamp (9874-1023)	9	65C-43	Cable Clamp (9900-1052)
5	65C-39	Hose Barb Fitting (9874-1196)	10	65C-44	Electrical 4 Pin Connector (9923-1059)
			11*	65C-45	Back-wash Pump Assembly *(All Items Above)

## MICROFINE® 2 BACK-WASH PUMP PARTS LIST

### ELECTRIC IMMERSION BACK-WASH PUMP, THREE STAGE

ITEM NO.	CATALOG NO.	PART NAME
1	65C-1	Fan Housing
2	65C-2	Fan
3	65C-3	U-ring (PRA only)
4	65C-4	Stator Housing with Winding
5	65C-5	Screw
6	65C-6	Phillips-Head Screw, M4 X 14
7	65C-7	Terminal Box (Plastic)
8	65C-8	Gasket
9	65C-9	Phillips-Head Screw M4 X 14
10	65C-10	Terminal Board, 6-Pole
11	65C-11	Terminal Box Cover
12	65C-12	Terminal Box, Light Alloy
13	65C-13	Terminal Board Base
14	65C-14	Terminal Board, 9-Pole
15	65C-15	Ball Bearing, DIN 625
16	65C-16	Shaft with Rotor
17	65C-17	O-ring
18	65C-18	Key, DIN 6885-A 3 X 12
19	65C-19	Ball Bearing, DIN 625
20	65C-20	Seal (PRA only)
21	65C-21	Screw
22	65C-22	Bearing End Shield
23	65C-23	Pump Support
24	65C-24	Top Splash Ring
26	65C-26	Washer
27	65C-27	Seal
28	65C-28	Impeller
29	65C-29	O-ring
30	65C-30	Spacer
31	65C-31	Intermediate Chamber
32	65C-32	Insert
33	65C-33	Impeller, 1 <sup>st</sup> Stage
34	65C-34	Pump Bottom
35	65C-35	Pump, Electric Immersion

## MICROFINE® 2 BACK-WASH PUMP ASSEMBLY

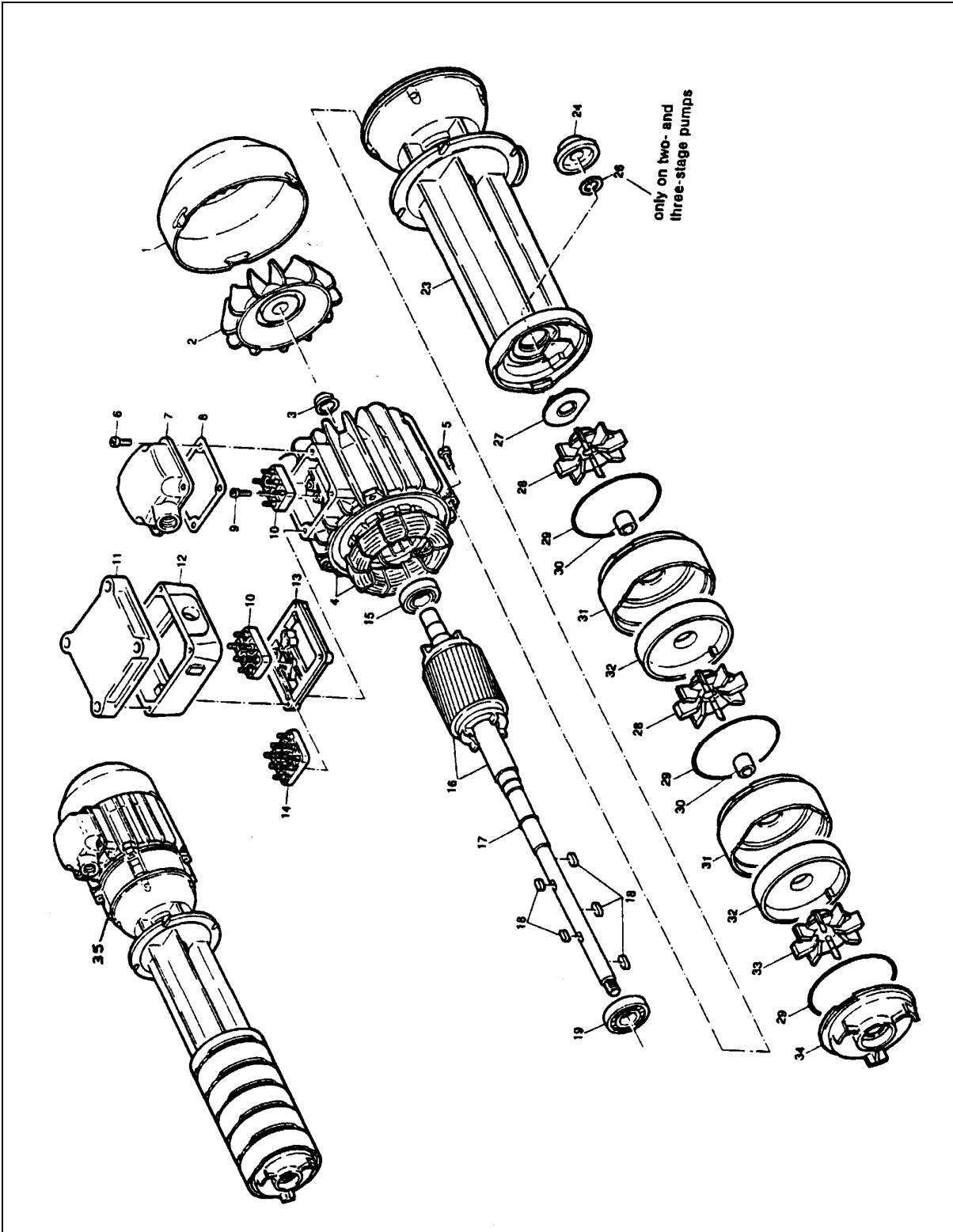

## MICROFINE® 2 BACK-WASH PUMP INSTALLATION & MAINTENANCE

Before installing the pump see if the pump shaft can be easily turned by hand. Install the pump so that the highest level reached by the coolant when the pump is not in operation is at least 20 mm. below the mounting flange of the pump. The supply line to be connected should have the same diameter as the threaded connection of the pump so that the pipeline resistance is kept to a minimum at full discharge delivery. The piping must be assembled in such a method that it is not subjected to stress. In no case may the pump serve as the anchor point for the piping. The fittings screwed into the discharge end of the pump should be provided with tapered threads. The torque required to screw the fitting into the discharge port of the pump must not exceed 35 Nm, as otherwise there is the danger it will rupture or break off! When connecting the discharge line by means of a hose sleeve insure that the hose is not kinked. Cut the threads of the discharge hose cleanly so that the threaded connection is not damaged. Since the impeller runs below the surface of the coolant, it is not necessary to prime the piping.

In the case of the immersion pumps with pipe extensions, the surface of the coolant must be above the pump chamber when the unit is turned on. If the surface of the coolant has dropped down to the pipe extension, the pump must not be temporarily switched off as otherwise the column of liquid would collapse and no pumping could be done until the coolant level rose above the impeller chamber again.

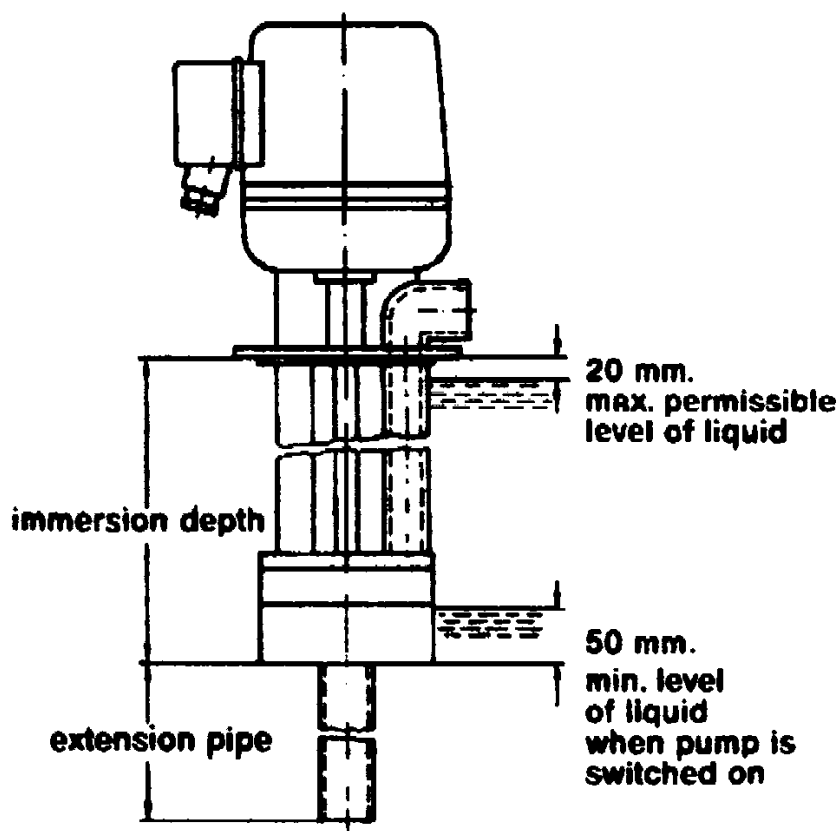

The pump drive motor has a fail-safe winding in accordance with insulation class "F". The units are operated in accordance with insulation class "B" and can be used up to an ambient temperature of 400C and a relative humidity of 92%. The main or basic voltage corresponds to DIN IEC 38, edition of May 1987 (230/400 +/- 10% unless otherwise specified).

The pump should be prewired and connected to a control if purchased with a conveyor/coolant system. However if replacing the pump, connect the pump motor in accordance with details on the rating plate which corresponds to the main voltage being supplied to the pump. If the motor is wound for delta/star, make the connection at the lower voltage in case of delta and at the higher main voltage in case of star. Make the star or delta connections on the terminal board in accordance with the following drawing using the jumpers supplied with the pump.

The pump normally comes from the factory wired for the higher voltage, e.g. for 400 V in the case of a 230/400 V supply. Make the electrical connection itself in accordance with the relevant VDE regulations, e.g. 0100, 0101 and 0165, as well as the regulations of the respective power supply companies. Cables and leads must be introduced into the pump terminal box via a screwed cable gland and tension relief in accordance with DIN 46255.

When the pump is switched on for the first time, make sure the pump direction of rotation agrees with the direction of rotation designated by the arrow on the pump. Running the pump backwards for an extended period of time may damage the pump and will cause the conveyor/coolant system to malfunction.

### Δ-connection

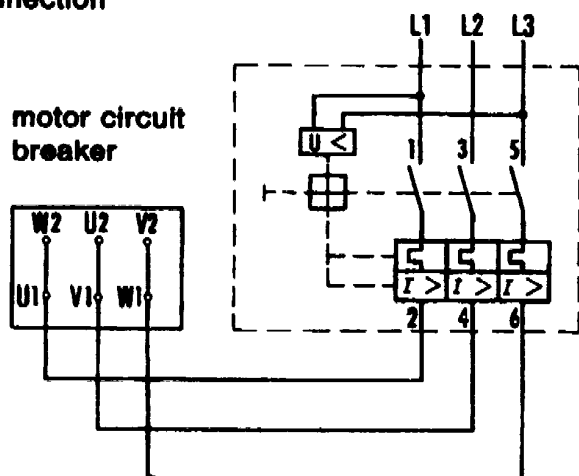

230 VOLT WIRING DIAGRAM

### Y-connection

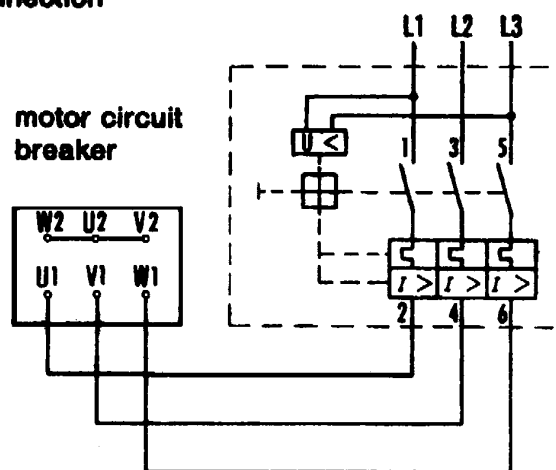

460 VOLT WIRING DIAGRAM

## BACK-WASH PUMP ELECTRICAL CONNECTIONS (SHOWN ABOVE)

The surfaces of the pump motor must be kept free from dust, discarded rags, etc. do that there is a good exchange of heat between the motor and ambient air so that the surface cooling is not jeopardized.

If a pump has been stored unused for a long period of time in a damp room, it is advisable to measure the dielectric resistance between the winding and housing before start-up. In case of low-voltage motors the minimum value at a winding temperature of approximately + 200 C is 2 MO. If the resistance is lower, the motor must be dried in a warm room or with heaters until necessary dielectric value is reached.

The pump shaft and rotor run on ball bearings with a filling of grease that is adequate for one or two years.

## BACK-WASH PUMP MAINTENANCE

### **WARNING!**

**REPAIR WORK MUST BE CARRIED OUT ONLY WHEN THE MACHINE HAS BEEN DISCONNECTED FROM THE POWER SUPPLY BY AUTHORIZED AND TRAINED MAINTENANCE SPECIALIST. WORK CARRIED OUT ON MACHINES THAT HAVE NOT BEEN DISCONNECTED CAN CAUSE SERIOUS PERSONAL INJURY!**

The back-wash pump is largely maintenance-free, but they should be checked regularly for external damage or leakage.

The pumping media as well as pre-filters or filter baskets must be checked for dirt and cleaned or replaced as appropriate.

The surfaces of the pump motor must be kept free of dust, dirt, foreign bodies, etc., so that a good heat exchange can take place between the motor and ambient air. This will prevent the motor from overheating.

Cables and wires must be checked for damage and firm electrical connections at regular intervals. Any defects must be immediately corrected immediately by an authorized and trained maintenance specialist before the pump is put back into operation again.

If a pump has been stored unused for a long period in a damp place, it is advisable to measure the insulation resistance of the coil ( as recommended in the previous section) before the pump is put into operation again.

### BACK-WASH PUMP REPAIR INSTRUCTIONS

When replacing repair parts on the back-wash pump, the following disassembly and assembly procedure should be used.

- 1 Turn power off to conveyor and Back-wash Pump.
- 2 Disconnect electric wires from pump.
- 3 Remove any plumbing connected to the pump.
- 4 Remove pump from coolant tank and place on bench.
- 5 Remove pipe from bottom of pump.
- 6 Place pump up side down on bench.
- 7 Turn Pump Bottom (catalog number 65C-34) counter clock wise until loose and remove.
- 8 With the pump in the up side down position, hold the shaft with a pair of pliers and turn the Impeller, 1<sup>st</sup> Stage (catalog number 65C-33) until the Impeller has been removed from the shaft. When holding the shaft with the pair of pliers be careful not to damage the Top Splash Ring (catalog number 65C-24). It may be helpful to use a screwdriver or something flat placed between the vanes of the Impeller to help turn the Impeller.
- 9 Remove the Insert (catalog number 65C-32) by sliding it out the open end of the pump.
- 10 Turn the Intermediate Chamber (catalog number 65C-31) 1/8 turn counter clockwise and remove from the shaft. A tap from a hammer and screwdriver on the Intermediate Chamber may be required to loosen it so it can be removed. Place the end of the screwdriver in the notch between the top of the Intermediate Chamber being removed and the bottom of the next chamber.
- 11 Remove the Spacer (catalog number 65C-30) by sliding it off the end of the shaft.

- 12 Gently pry under the Impeller (catalog number 65C-28) with one or two screwdrivers to slide the Impeller up and off the shaft. The Impeller is keyed and pressed lightly onto the shaft.
- 13 Remove the Insert (catalog number 65C-32) by sliding it out the open end of the pump.
- 14 Turn the Intermediate Chamber (catalog number 65C-31) 1/8 turn counter clockwise and remove from the shaft. A tap from a hammer and screwdriver on the Intermediate Chamber may be required to loosen it so it can be removed. Place the end of the screwdriver in the notch between the top of the Intermediate Chamber being removed and the bottom of the next chamber.
- 15 Remove the Key (catalog number 65C-18) from the shaft.
- 16 Remove the Spacer (catalog number 65C-30) by sliding it off the end of the shaft.
- 17 Gently pry under the Impeller (catalog number 65C-28) with one or two screwdrivers to slide the Impeller up and off the shaft. Support the shaft by holding the shaft with a pair of pliers when removing this last Impeller. **The shaft must be supported at this time or damage to the motor will occur.** The Impeller is keyed and pressed lightly onto the shaft.
- 18 Make sure the key (catalog number 65C-18) is in position for the last Impeller. **Continue to support the shaft.**
- 19 Slide the new Impeller (catalog number 65C-28) onto the shaft with the vanes of the Impeller facing the bottom of the pump. Align the keyway in the Impeller and the key in the shaft and press the Impeller down into position. **The shaft must continue to be supported until the Impeller has been pressed all the way down into position.**
- 20 Slide the Spacer (catalog number 65C-30) onto the shaft.
- 21 Place the Key (catalog number 65C-18) back into the keyway above the Spacer.
- 22 Place the Intermediate Chamber (catalog number 65C-31) back on the shaft with the seal facing the top of the pump. Turn the chamber clockwise until it locks into position. Make sure the seal on the top of the Intermediate Chamber is clean and in position before installing. Make sure the chamber is level when it is in its final position.
- 23 Place the Insert (catalog number 65C-32) on the shaft with the vanes of the Insert facing the top of the pump. Slide the Insert down into the Intermediate Chamber (catalog number 65C-31). There are three small pins molded into the top of the Insert that set in three holes in the inside of the Intermediate Chamber, turn the Insert until the pins set into the holes in the chamber.
- 24 Slide the new Impeller (catalog number 65C-28) onto the shaft with the vanes of the Impeller facing the bottom of the pump. Align the keyway in the Impeller and the key in the shaft and press the Impeller down into position.
- 25 Slide the Spacer (catalog number 65C-30) onto the shaft.
- 26 Place the Intermediate Chamber (catalog number 65C-31) back on the shaft with the seal facing the top of the pump. Turn the chamber clockwise until it locks into position. Make sure the seal on the top of the Intermediate Chamber is clean and in position before installing. Make sure the chamber is level when it is in its final position.
- 27 Place the Insert (catalog number 65C-32) on the shaft with the vanes of the Insert facing the top of the pump. Slide the Insert down into the Intermediate Chamber (catalog number 65C-31). There are three small pins molded into the top of the Insert that set in three holes in the inside of the Intermediate Chamber, turn the Insert until the pins set into the holes in the chamber.
- 28 Screw the new Impeller 1<sup>st</sup> Stage (catalog number 65C-33) onto the shaft and screw it on in a counter clockwise direction until it is tight.

- 29 Place the Pump Bottom (catalog number 65C-34) onto the bottom of the pump with the pipe threaded end facing the bottom of the pump. Turn the Pump Bottom in a clockwise direction until it is tight.
- 30 Replace the pipe that was removed in step no. 5 into the Pump Bottom.
- 31 Place the pump into the coolant tank in the same location and position in which it was removed.
- 32 Connect all plumbing removed from the pump in step no. 3.
- 33 Connect the electrical wires to the pump.
- 34 Turn the power on and test the pump.

## **OPTIONAL AIR HEADER INSTALLATION AND OPERATION**

The upper conveyor on your Microfine® 2 conveyor may be equipped with an air header assembly. An air header is an attachment mounted under the belt, near the discharge end, that directs multiple streams of compressed air onto the belt to dislodge small chips that might otherwise be carried back down into the conveyor frame. Cutting applications for aluminum, brass and other non-ferrous materials are good candidates for the use of an air header since these types of chips tend to cling to the belt and do not fall off of the conveyor belt easily at the discharge.

This assembly ships loose with the conveyor. To assemble this unit, follow the procedure below:

1. Mount the regulator bracket to the conveyor side frame using the two hex head cap screws, lock washers and flat washer provided. There will be a block welded to the side frame of the conveyor for mounting this bracket.
2. Insert the air header manifold tube through mounting holes in the conveyor discharge and secure it with the button head screw, flat washer and lock washer provided. (Note: insert the screw from the inside of the conveyor discharge as shown below).
3. Connect the air hose provided to the air header input. The fitting on the end of the hose slides over the end of the air header manifold tube.
4. Connect customer supplied shop air to the regulator input (quick connect male fitting supplied). The normal air pressure required is 10 to 20 p.s.i. depending upon the conveyor belt width (see the air requirement chart below). However, use the lowest pressure required that effectively removes the chips from the belt. If the pressure is too high, coolant misting may occur.

		AIR REQUIREMENT CHART (CFM)							
		BELT WIDTH (INCHES)							
		4	8	12	16	20	24	30	36
AIR PRESSURE (PSI)	10	1.5	2.9	4.2	5.6	6.4	8.7	11.6	13.8
	12	1.7	3.1	4.6	6.1	7.1	9.5	12.7	15.2
	14	1.8	3.4	5.0	6.6	7.6	10.3	13.7	16.4
	16	1.9	3.6	5.3	7.1	8.2	11.0	14.7	17.6
	18	2.1	3.9	5.7	7.5	8.7	11.7	15.6	18.6
	20	2.2	4.1	6.0	7.9	9.1	12.3	16.4	19.6



## AIR HEADER ASSEMBLY

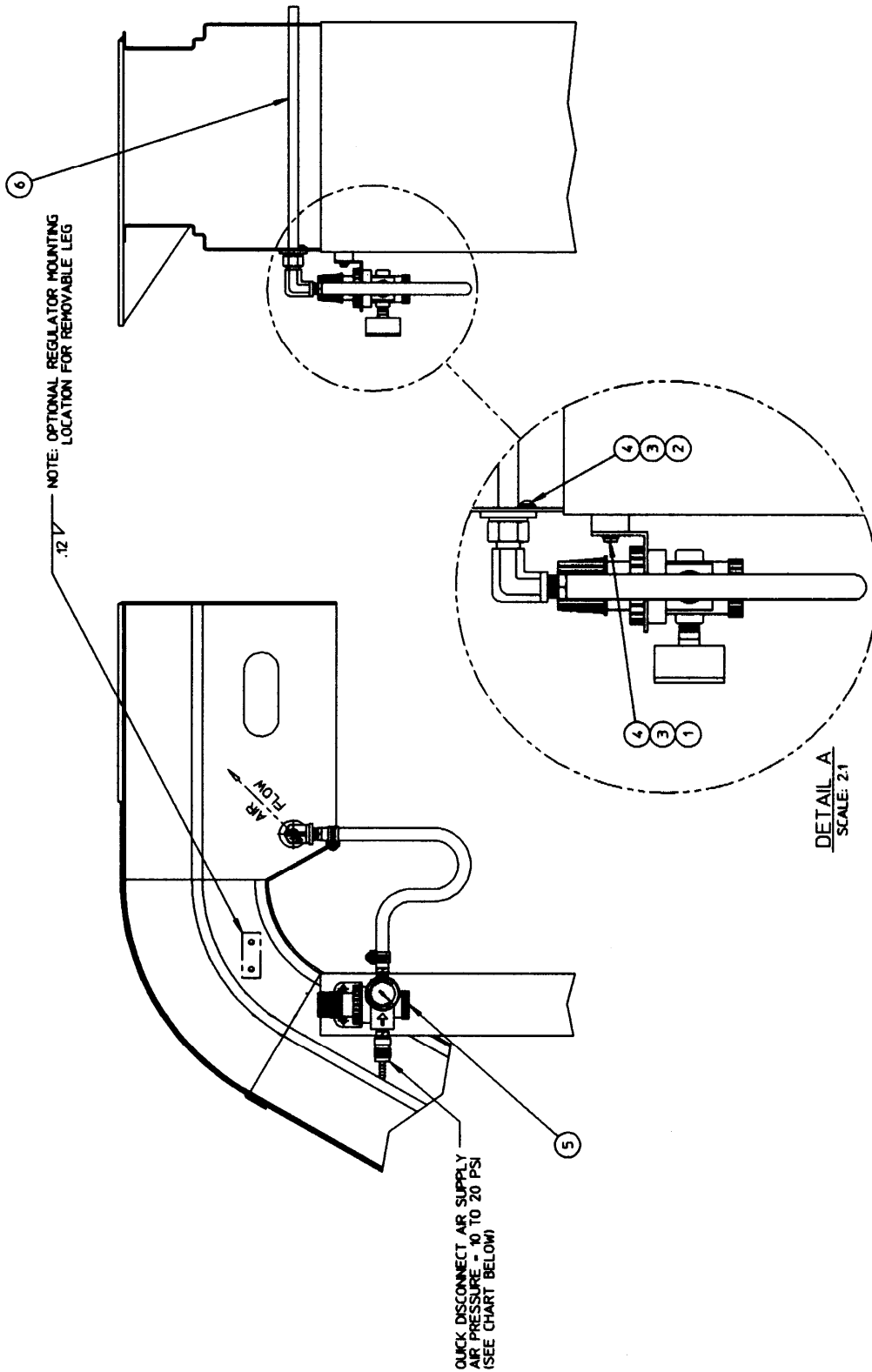

ITEM NO.	CATALOG NO.	PART NAME	ITEM NO.	CATALOG NO.	PART NAME
1	75C-200	Screw, HHC 1/4-20 X 1/2" (8820-1001)	4	75C-203	Flat Washer, 1/4" (8856-1002)
2	75C-201	Screw, BHC 1/4-20 X 1/2" (8826-1014)	5	75C-204	Air Header Basic Assembly (6299-9218)
3	75C-202	Lock Washer, 1/4" (8855-1009)	6	75C-205	Air Header Manifold Weldment

## AIR HEADER BASIC ASSEMBLY

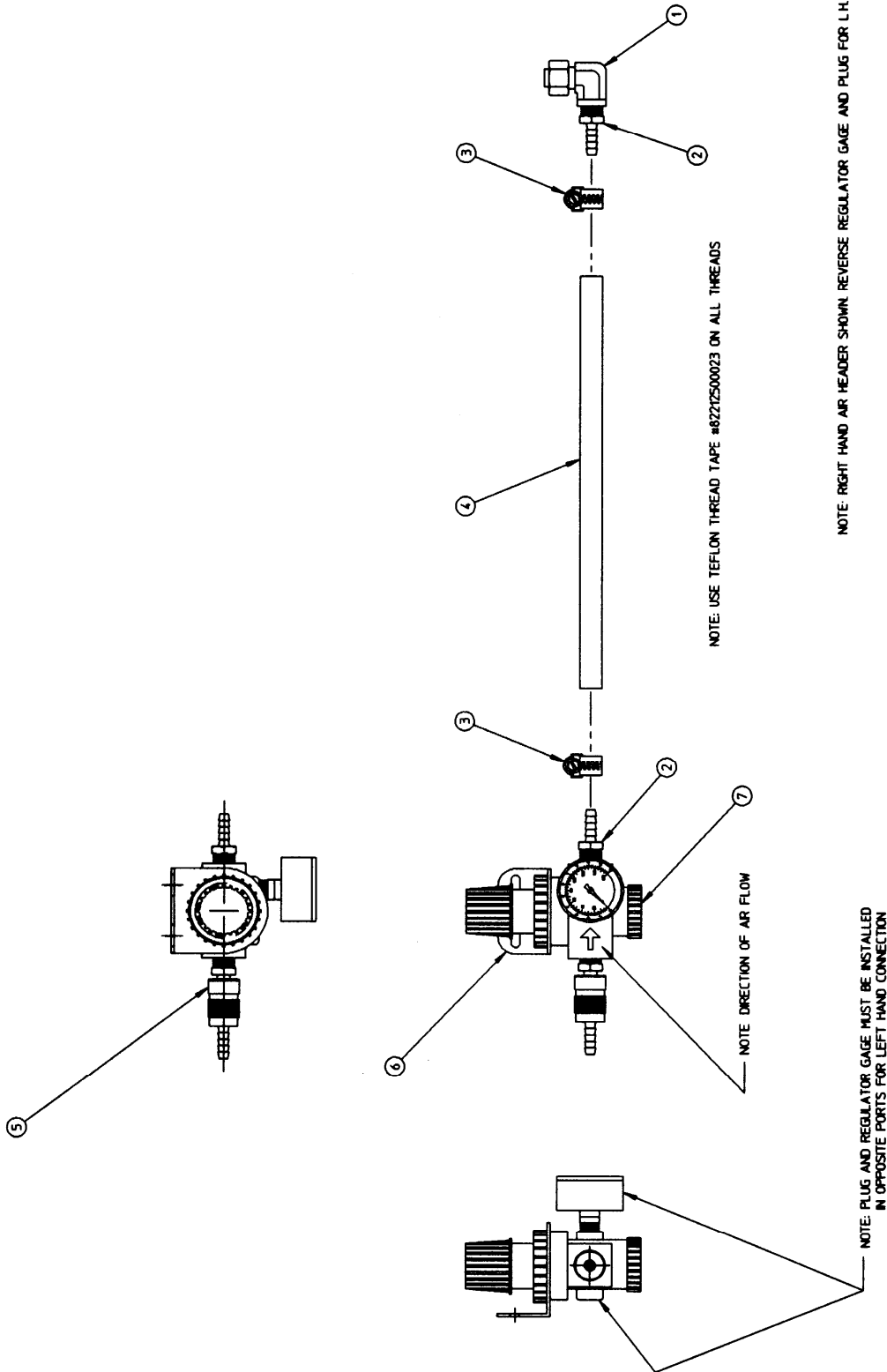

ITEM NO.	CATALOG G NO.	PART NAME	ITEM NO.	CATALOG NO.	PART NAME
1	75C-207	Female Elbow (9866-1040)	5	75C-211	Quick Connect Coupling (9874-1019)
2	75C-208	Hose Nipple Barb Fitting (8874-1801)	6	75C-212	Mounting Bracket, Regulator (9873-1003)
3	75C-209	Hose Clamp (9874-1020)	7	75C-213	Air Regulator with Gage (9888-1039)
4	75C-210	Air Hose (9874-1019)			

### OPTIONAL CHIP STRIPPER BAR

A chip stripper bar is an adjustable, serrated steel bar mounted under the belt, near the discharge end of the conveyor, designed to snag stringy chips and prevent them from being carried back down into the conveyor frame.

Normally the chip stripper bar should be mounted as shown below so the serrations on the bar are positioned to snag the chips as the belt travels around the sprocket at its lowest point. Periodically as the conveyor belt is adjusted to maintain proper belt tension, the chip stripper bar will need to be adjusted accordingly to maintain the serrated teeth position to the belt.

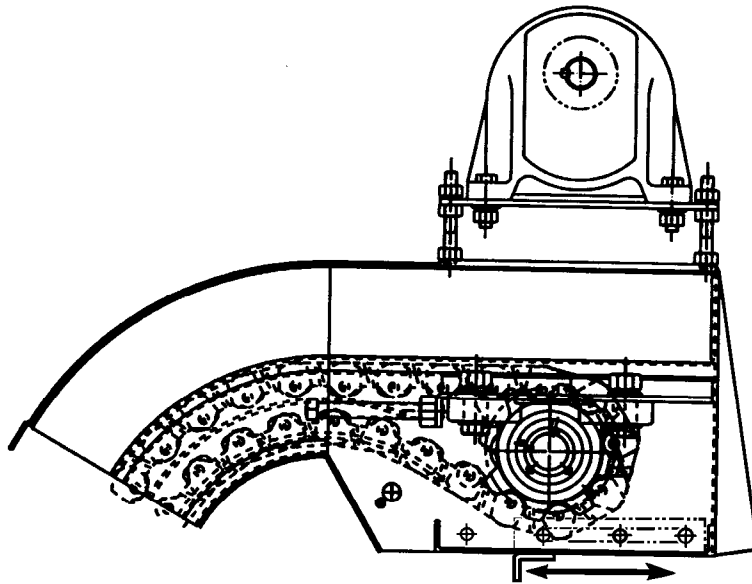

If the chip stripper bar is not purchased from the factory with the conveyor, but is ordered as a retrofit option, the following procedure should be followed to install the chip stripper bar.

1. Layout and drill three (3) .281 diameter holes in each side of the conveyor frame as shown below.

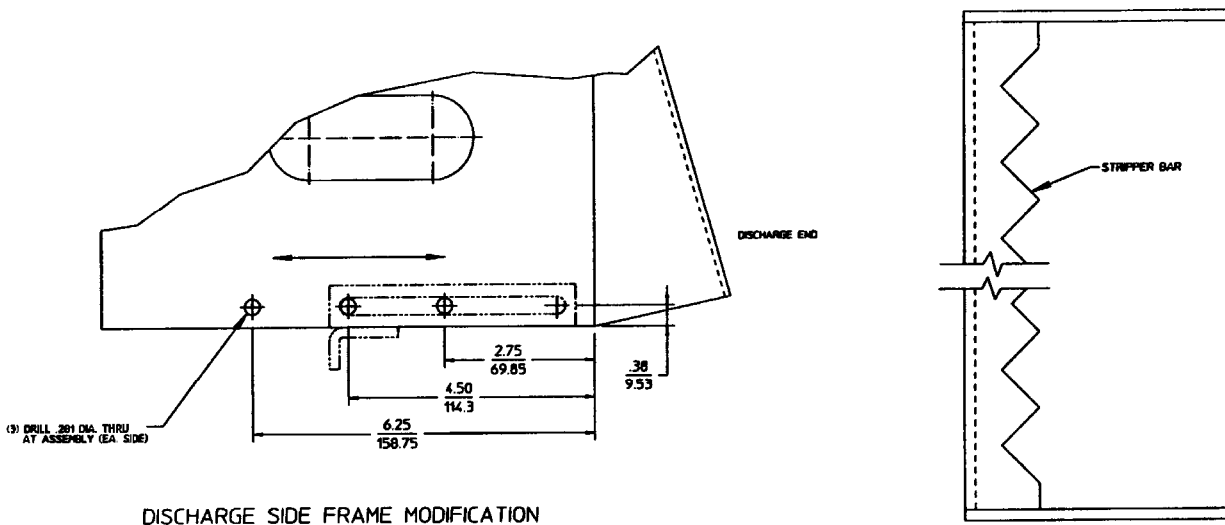

2. Locate the chip stripper bar per the sketch above and mount it to the conveyor frame using the hardware provided with this option. See the sketch below for proper hardware mounting.

(8826-1015)  
1/4-20 X 5/8 BUTTON HD. SCREW (4)

(8855-1009)  
1/4 LOCKWASHER (4)

(8850-1004)  
1/4-20 HEX NUT (4)

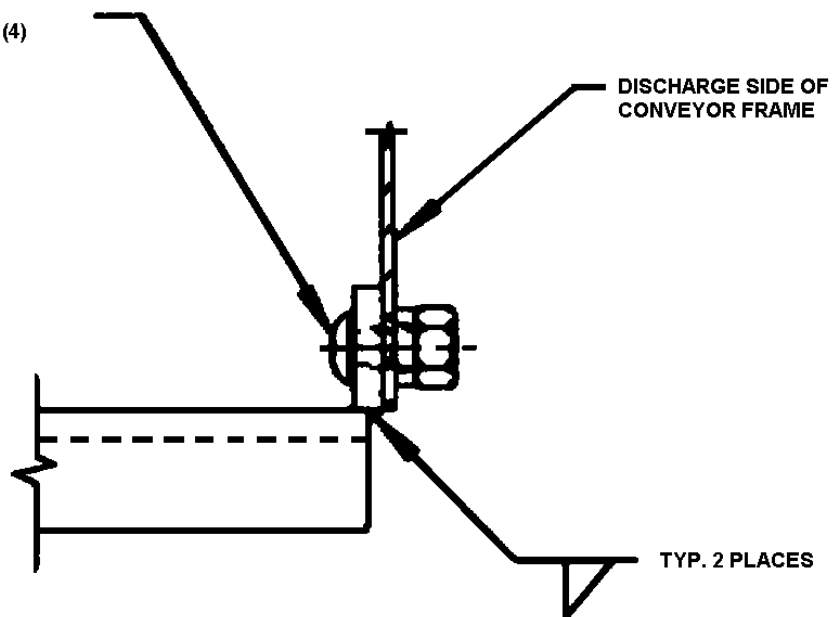

## MICROFINE® 2 ELECTRICAL INFORMATION

LNS chip conveyors are supplied with a variety of drive packages and electrical controls, depending on conveyor application and customer preference. Only a qualified electrician or machine service technician should perform any maintenance, repairs or adjustments on this equipment.

### **WARNING!**

**ONLY QUALIFIED ELECTRICIAN OR SERVICEMAN SHOULD PERFORM ANY ELECTRICAL TROUBLESHOOTING OR MAINTENANCE TO THIS EQUIPMENT.**

**DO NOT PERFORM ANY MAINTENANCE, REPAIRS OR ADJUSTMENTS ON THIS EQUIPMENT WITHOUT FIRST LOCKING OUT ALL ELECTRICAL CONTROLS.**

**PERSONNEL SHOULD BE TRAINED IN OSHA COMPLIANT LOCK-OUT/TAG-OUT AND ELECTRICAL SAFETY PROCEDURES.**

**MAKE CERTAIN THAT THE POWER SUPPLY IS DISCONNECTED BEFORE ATTEMPTING TO SERVICE OR REMOVE ANY COMPONENTS!**

**AT NO TIMES SHOULD CIRCUIT CONTINUITY BE CHECKED BY SHORTING TERMINALS WITH A SCREWDRIVER OR OTHER METAL DEVICE.**

**NEVER SHOULD ADJUSTMENTS, MAINTENANCE OR CLEANING BE PERFORMED WITHOUT FOLLOWING PROPER SAFETY PROCEDURES IN ACCORDANCE WITH LOCAL, STATE AND NATIONAL SAFETY CODES.**

Before making any electrical connections be certain the voltage for which the conveyor drive and control are wired is the same as incoming voltage being delivered by the electric power supply. Failure to do so may result in injury or damage to the equipment. It may be necessary in the case of 220/440V, 3 phase, for example, to change the motor wiring from one voltage to another. Normally a wiring diagram is located inside the motor terminal box, which indicates proper wiring for the incoming voltage supplied.

Some machines are equipped with internal electrical controls and a multi-pin type accessory plug for connecting the chip conveyor. LNS chip conveyors can be ordered with a mating plug, so that connecting the conveyor is as simple as plugging it in.

The best and most common source of power for the chip conveyor is the machine electrical cabinet. It is the customer's responsibilities at the time of order to determine what, if any, electrical components are present and/or order the appropriate conveyor control.

Even if the machine has no plug or other provision for connecting a chip conveyor, the conveyor should be ordered from LNS with both halves of a quick-disconnect style plug. One half will come pre-wired to the conveyor control cable. The other half of the plug will be wired to the machine electrical cabinet where it will be connected to the power supply. The chip conveyor can then be quickly unplugged for cleaning or service without having to disconnect "hard wired" connections.

Before starting the chip conveyor, check to be sure no tools, packing, or other material have been left on the belt or in the discharge opening. Start the conveyor and verify proper direction of belt travel. Reverse polarity if the belt is moving in the wrong direction. Check the rotation of the filter drum and back-wash coolant pump. If either of these motors is running backwards, reverse the polarity. If the conveyor belt, filter drum or back-wash pump runs backwards for an extended period of time it may result in the conveyor not operating effectively and/or cause damage to the conveyor.

## TYPICAL MICROFINE® 2 ELECTRICAL CONTROL BOX SCHEMATIC

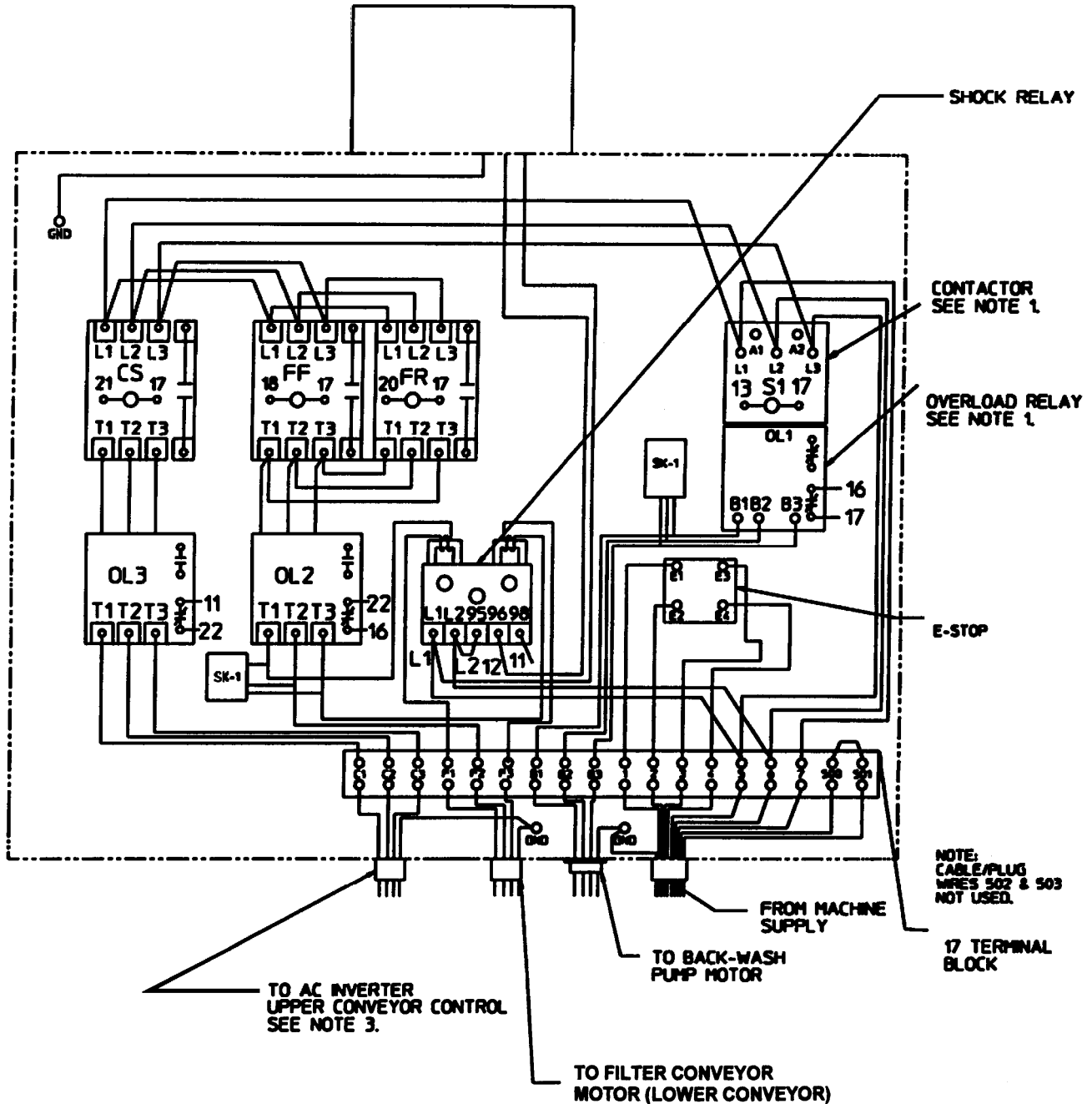

NOTE 1: The terminal block, contactor and overload relay are mounted on inside rear panel of enclosure.

NOTE 2: Contactor and overload coils are voltage specified on purchase order for equipment.

NOTE 3: The conveyor motor control circuit is not separately fused. The user must provide a circuit breaker or a fused disconnect switch on the power supply to the conveyor.

### TYPICAL MICROFINE® 2 ELECTRICAL CIRCUIT DIAGRAM

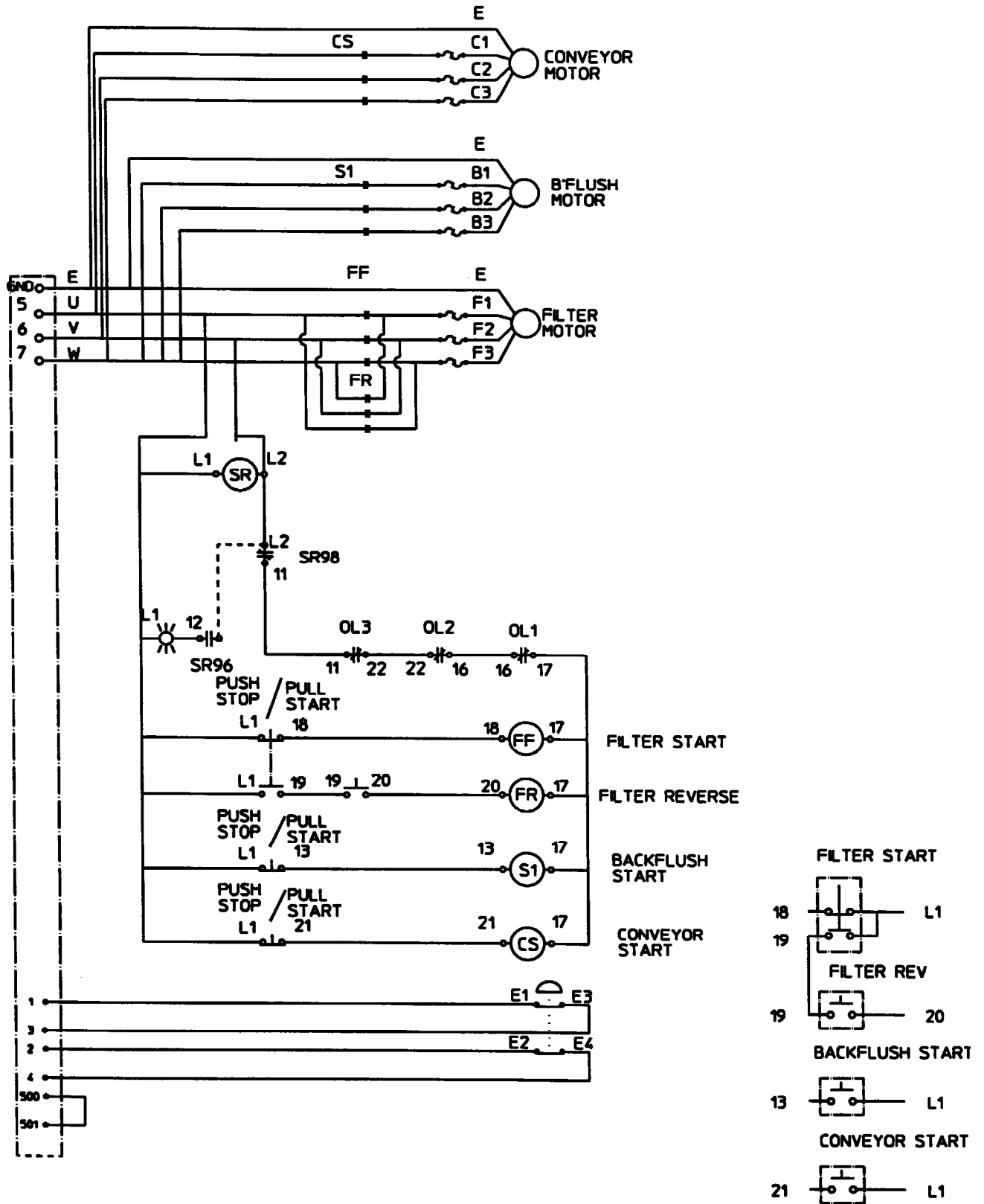

### TIME DELAY DEVICES

The use of a time delay device is prohibited on a Microfine® 2 Conveyor. If the conveyor is not running when the machine tool is cutting chips it may cause a large chip build up in the conveyor frame. When the conveyor is finally turned on it may not be able to handle the chip load. This condition may cause belt, frame and/or filter damage to the Microfine® Conveyor. It is imperative that the Microfine® 2 Conveyor is operating continuously whenever the machine tool is cutting chips. LNS will not be responsible for damage caused to the conveyor when a time delay device is being used.

### AC SUPPLY CIRCUIT AMP LOAD FOR MICROFINE® CONVEYORS

Your LNS chip conveyor may be equipped with two AC motors to drive each of the two conveyors and a variable speed AC inverter control unit. The full load amp draw of the AC drive is based on the horsepower of the AC motor, as well as the input AC voltage. The Turbo MICROFINE® 2 model, is normally equipped with an AC back-wash pump. These motors will place an additional load on the AC power supply circuit.

The conveyor motor control circuit is not separately fused. The customer must provide a circuit breaker or a fused disconnect switch on the power supply to the conveyor

It may be necessary to change a circuit protection device on the incoming power supply line to accommodate the higher full load amp draw. Refer to the following tables to determine the full load amp draw on the AC supply circuit:

### AC CURRENT REQUIREMENTS FOR MICROFINE® 2 CONVEYORS

Voltage 3 Phase	Belt Drive Type	Belt Drive Horsepower	Back- wash Pump	Current per phase at Rated Load	Maximum Overload Relay Setting (150% x Rated Current)
230 VAC	Variable Speed	¼	Yes	3.41 A	5.00 A
460 VAC	Variable Speed	¼	Yes	1.78 A	2.60 A

\* 84% average inverter efficiency

### VARIABLE SPEED DRIVE

The belt speed of the upper conveyor is controlled by a variable speed inverter drive located on the conveyor electrical control panel. The conveyor belt speed is adjustable from near zero to approximately 9 feet per minute. The belt speed should be set at the lowest possible speed that will remove chips fast enough to keep them from accumulating in the load section of the conveyor. Setting the belt speed too low may allow chips to build up in the horizontal load section of the conveyor and eventually cause a conveyor jam. Setting the belt speed too fast increases the amount of coolant carried out into the chip container.

**Note:** The variable speed control should not be used as an ON-OFF switch. Only the ON-OFF switch or the REV-STOP-FWD switch should be used to turn the conveyor motor on or off.

The control is designed for safe and convenient operation. All controls are mounted on the front cover. No access to the inside of the control enclosure is required.

The OFF/FORWARD switch controls the incoming line power to the inverter. It must be in the FORWARD position for the conveyor to operate.

A momentary JOG REVERSE button is provided on the variable speed control panel in case the belt direction must be momentarily reversed. This option is normally used to assist in clearing a conveyor jam if one occurs.



The SPEED CONTROL potentiometer controls the inverter output frequency. The conveyor belt speed can be varied from nearly zero to the maximum using this control.

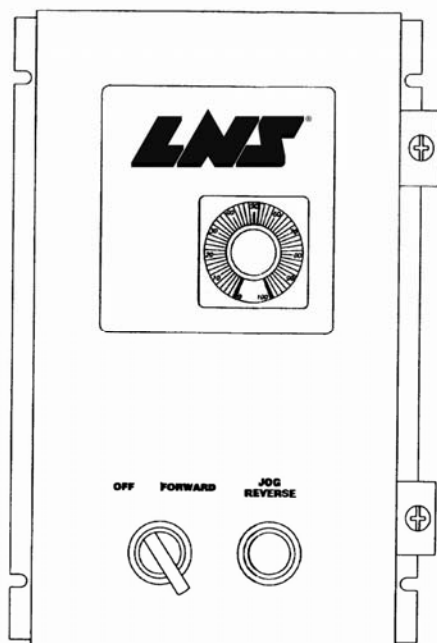

**CONTROL PANEL OF VARIABLE  
SPEED CONTROL**

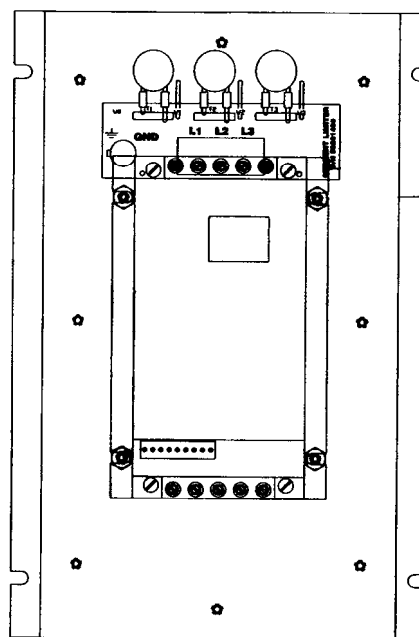

**INSIDE VIEW OF VARIABLE  
SPEED CONTROL**

## MICROFINE® 2 ELECTRICAL CONTROL PANEL

The Microfine® 2 electrical control panel will normally consist of a variable speed inverter drive for the upper conveyor and a basic conveyor system control panel. These control panels will vary depending upon machine tool conveyor interfaces and options required by the customer. For example, the customer or manufacture may chose to supply their own back-wash pump. However, normally most MICROFINE® 2 conveyors will have the basic functions covered in this section of the manual.

If the conveyor is controlled through the machine tool control, make sure that the variable speed control is always turned to the forward position, the filter start/stop button is pulled out (start position), the conveyor start/stop button is pulled out (start position), the back-wash start/stop button is pulled out (start position) and the conveyor e-stop button is pulled out (on position). Failure to do so will result in the conveyor system or portions of the system not operating.

The following section will cover the basic MICROFINE® 2 conveyor control operation and functionality.

## MICROFINE® 2 ELECTRICAL CONTROL PANEL

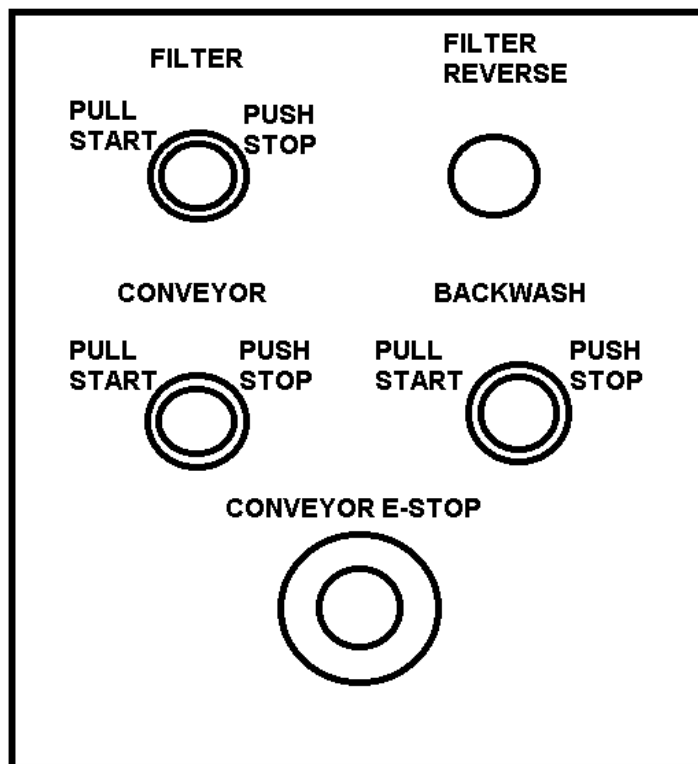

### FILTER START/STOP BUTTON

The FILTER START/STOP button can be manually pulled out or pushed in to start and stops the lower (filter) conveyor. This button must be pulled out for the lower conveyor to operate.

### FILTER REVERSE BUTTON

The FILTER REVERSE button is a momentary reverse button to change the direction of the filter conveyor motor thus reversing the belt rotation direction and the filter drum rotation. This button must be depressed and held in to reverse the belt/filter rotation. Normally, this button is only used by maintenance personnel for unjamming the belt or clearing a blockage at the filter.

### CONVEYOR START/STOP BUTTON

The CONVEYOR START/STOP button can be manually pulled out or pushed in to start and stop the upper conveyor. This button must be pulled out for the upper conveyor to operate. It is always a good idea to insure that the upper conveyor belt is moving after the conveyor system is turned on.

### BACK-WASH START/STOP BUTTON

The BACK-WASH START/STOP button can be manually pulled out or pushed in to turn on and off the back-wash pump motor. This button must be pulled out for the back-wash pump to operate. It is always good idea to check the pressure gage on the inline filter to insure coolant pressure is being supplied to the back-wash spray system. If the back-wash spray system is not operating, the filter drum will become clogged. This situation will cause the conveyor to overflow coolant possibly spilling coolant onto the floor and/or contaminating the clean side of the coolant tank.

## EMERGENCY STOP BUTTON

The emergency stop button is located on the conveyor control panel and is labeled CONVEYOR E-STOP. When this button is depressed it will shut down power to the conveyor system. This button must be pulled out for the conveyor system to operate. In some situations, the CONVEYOR E-STOP button may shut down the entire machine tool when depressed. The manufacturer of the machine tool will determine the function of the CONVEYOR E-STOP in relationship to the machine tool. The function of the CONVEYOR E-STOP button should always be tested upon installation to insure that the operation and function of this switch is working correctly.

## RED ALARM LIGHT

A red alarm light is located on top of the conveyor electrical control box. If this alarm light is flashing it means that the shock relay has been tripped for the lower conveyor and therefore the conveyor system has been shut down. Please check the instructions below for setting the shock relay to insure it is set correctly. If so, the lower conveyor drive motor amperage has exceeded the normal overload amperage setting in the shock relay. Refer to the trouble-shooting guide in this manual to assist with determining the cause of the problem. Failure to correct this problem and continue conveyor operations will result in the lower conveyor filling up with chips. This may cause damage to the lower conveyor and will definitely add increased downtime to repair the conveyor.

## SHOCK RELAY

The lower conveyor is protected by a shock relay, which is located inside of the conveyor control box. The shock relay is preset at the factory. If the shock relay trips out, do not change the amperage setting or the response time of the shock relay without consulting with LNS' Service Department. Please check the instructions below for setting the shock relay to insure it is set correctly. If so, the lower conveyor drive motor amperage has exceeded the normal overload amperage setting in the shock relay. Normally, if the conveyor trips the shock relay after a successful run period there is some type of conveyor jam, which must be cleared before continuous conveyor operation can be resumed. Refer to the trouble-shooting guide in this manual to assist with determining the possible cause of the problem. Failure to correct this problem and continue conveyor operations will result in the lower conveyor filling up with chips. This may cause damage to the conveyor and will definitely add increased downtime to clean out the conveyor.

**SETTING THE SHOCK RELAY INCORRECTLY CAN CAUSE DAMAGE TO THE CONVEYOR, WHICH WILL NOT BE COVERED UNDER WARRANTY!**

## INSTRUCTIONS FOR SETTING SHOCK RELAY

1. Set start time to 2 seconds.
2. Set current at maximum
3. Set shock time to minimum.
4. Start filter conveyor, push test. Filter conveyor should stop. Push Rest.
5. Restart filter conveyor, turn load current down slowly until the filter conveyor stops.
6. Adjust the load current up slightly.
7. Adjust start time down slightly. Start the filter conveyor if the shock relay trips adjust the start time back up.