

marathon™

Generators

MagnaMax^{DVR}®

Installation, Operation, and
Maintenance Manual

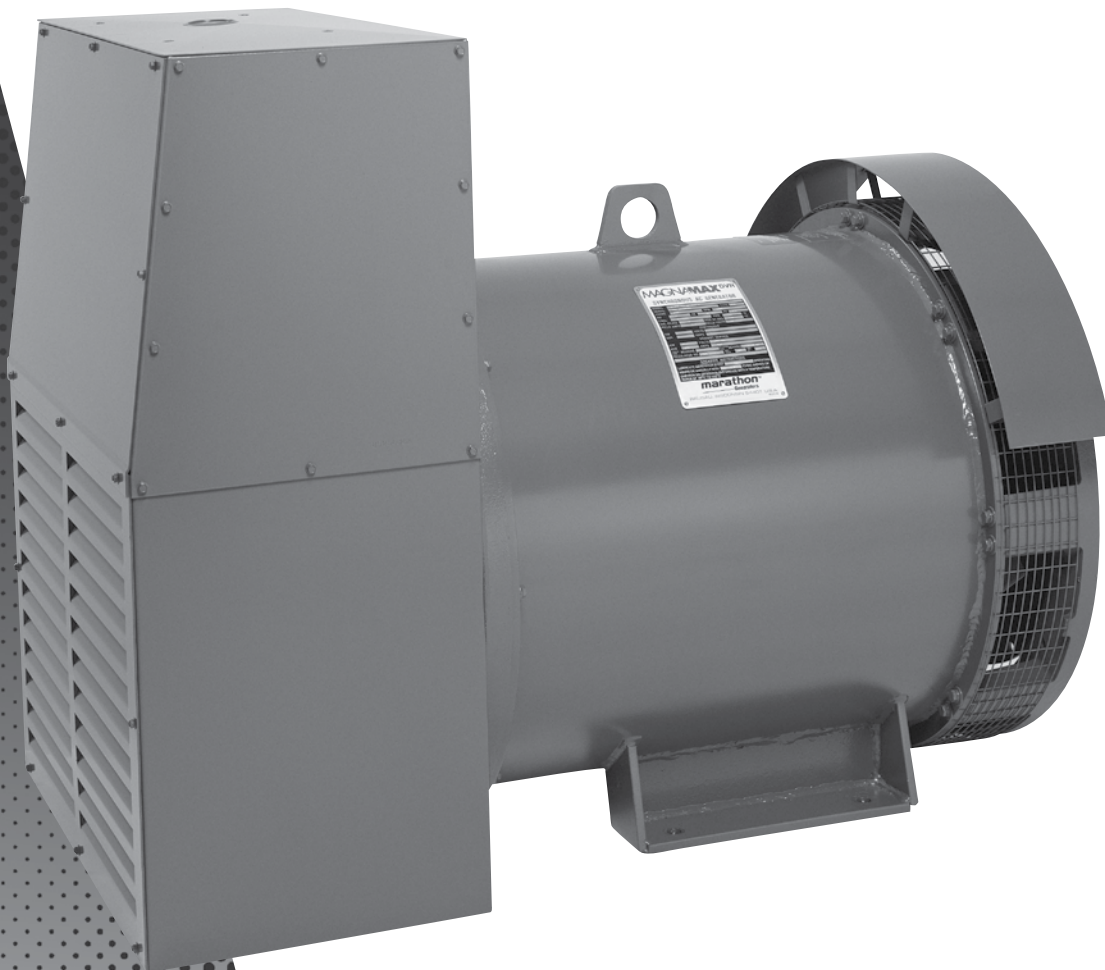

A Regal Brand

REGAL

Table of Contents

Section		Page
1	Safety	1
2	General Information	2-3
3	Installation	4-13
4	Operation.	14-15
5	Maintenance	16-19
6	Service	20-38
7	Troubleshooting	39-46
8	Generator Testing	47-50
9	Parts	51-52
10	Special Tools	53-54
11	Preparation for Shipment or Extended Storage.	55
12	Specifications.	56-60
	Generator Formulas.	61
	Warnings & Cautions.	62-Back Inside Cover

A Few Words About Safety

PLEASE REMEMBER SAFETY FIRST. If you are not sure of the instructions or procedures, seek qualified help before continuing.

This service manual emphasizes the safety precautions necessary during the installation, operation and maintenance of the MAGNAMAX^{DVR®} generator.

Each section has caution and warning messages. These messages are for your safety and the safety of the equipment involved. If any of the cautions or warnings are not readily understood, seek clarification from qualified personnel before proceeding.

Before any service work is done, disconnect all power sources and, where appropriate, lock out all controls to prevent an unexpected start-up of the generator set. Proper grounding in compliance with local and national electrical codes must be provided. These safety precautions are necessary to prevent potential serious personal injury, or even death.

The hazards associated with lifting or moving the MAGNAMAX^{DVR®} generator are pointed out in the installation and service sections; incorrect lifting or moving can result in personal injury or property damage.

Whenever the generator is running, always assume and proceed as if voltage is present. Residual voltage is present at the generator leads and at the regulator panel connections, even with the regulator fuse removed. Caution must be observed. Otherwise, serious personal injury or death can result.

Whenever solvents, cleaners, or flammable liquids are present, adequate ventilation must be available to avoid fire, explosion, and health hazards. Always avoid breathing vapors and use suitable personal protective equipment to prevent personal injuries (such as eyes, face, and hand protection).

This manual is not intended to be a substitute for properly trained personnel. Repairs should only be attempted by qualified, trained people. The cautions and warnings point out known conditions that are potentially dangerous. Each installation will create its own set of circumstances. No manual can cover every possible situation.

When in doubt, ask. Don't be embarrassed to ask "dumb questions." Remember, dumb questions are much easier to handle than dumb mistakes.

General Information

2

Mechanical Design

General

All single and two bearing units are manufactured with cast iron end brackets and adapters and fabricated steel frames. Flexible drive discs and SAE adapters are machined to SAE standards. Prelubricated, regreasable, shielded ball bearings are used on MAGNAMAX^{DVR} generators. Standard units are fully guarded. Dripproof shields are available as an option.

Conduit Box

The large, front end-mounted conduit box is constructed of formed sheet steel, which will allow the addition of top-mounted control packages. Refer to Marathon Electric for top mounted controls of more than 240 lbs. There is ample room inside the conduit box for a circuit breaker (through 800 amp ratings) and other options. The conduit box cover properly directs outside vent-tilating air through the generator.

MAGNAMAX^{DVR} Uni-rotor Construction

An aluminum die cast rotor core affords high mechanical integrity and low vibration at operating speeds. Amortisseur winding and coil supports are die cast as an integral part of the rotor. Laminations are 4-pole, one piece laminations which are shrunk fit and keyed to the shaft. No dovetails, cross bolts or other pole to shaft connecting devices are used. The cast unidirectional aluminum alloy ventilating fan provides even air distribution to maximize cooling and generator efficiency.

Adapters and Drive Discs

All single bearing units are available with several adapter and drive disc arrangements. These can be shipped to order or can be changed in the field with standard shop tools. When changing flexible drive discs, spacers are used between the discs and the cast iron hub to maintain SAE standard dimensions.

Electrical Design

General

All standard products have 2/3 pitch main windings to eliminate the third harmonic. This serves to lower operating temperatures, give lower harmonic content and better wave form, and extend the overall life of the generator. The phase sequence is ABC when rotated counterclockwise viewing exciter end.

Temperature Rise

All ratings and frame sizes are based on NEMA and CSA Class F and Class H temperature rises on both the rotor and stator windings. Ratings for international and marine applications are available.

Standby Generator

Synchronous generators used on emergency backup power can have temperature rises up to 25°C above those for continuous operation (NEMA MG1-22.40 and MG 1-22.84).

Premium Insulation System

All MAGNAMAX^{DVR} generators are built with Class H or better insulation materials. All standard generators are suitable for continuous duty at Class F temperature rise and will give equivalent or better winding life expectancy to generators supplied with Class A or B insulation systems operated within their temperature limits. The varnishes and epoxies used are synthetic, non-hygroscopic. Multiple dip and bake cycles of the main winding, plus a final coat of epoxy, make the standard winding moisture and fungus resistant. The MAGNAMAX^{DVR} rotor is wet wound with thermosetting epoxy applied between each layer, plus a final coating of epoxy for moisture and abrasion resistance. MAGNAMAX^{DVR} generators can be ordered with an epoxy vacuum pressure impregnated (VPI) insulation system as an option (MAGNAMAX^{DVR} generators with form wound coils include VPI as standard).

Power Factor

All standard generators are designed for operation at rated kVA at 0.8 lagging power factor but can be operated at rated kVA over the 0.8 to 1.0 power factor range.

MAGNAMAX^{DVR} Voltage Regulator

The standard voltage regulator is a fully encapsulated, static type with a solid state build up circuit. Standard features include 3 phase RMS sensing, paralleling, adjustable underfrequency protection, and overexcitation protection. Refer to the regulator manual for more information.

How to Read a Model Number

It is extremely important to properly identify the machine when requesting parts or service.

Always have available the generator model number and serial number when requesting information from the factory. We cannot help you without this information. It is also beneficial to know the mounting arrangement code (see figure 2-1).

An Example for MAGNAMAX^{DVR} Generators

Example: 431 RSL 4000 AA
 ① ②③④ ⑤⑥ ⑧

- ① Frame Number
- ② R – Random Wound
F – Form Wound
- ③ S – 1 Bearing
D – 2 Bearings
- ④ L – Up to 480 volts
S – 600 volts
M – 1000-6900 volts
- ⑤ Style
4-Magna (slant type conduit box)
8-Magna (square conduit box)
- ⑥ Model in Series
- ⑧ Electrical/mechanical modification—minor modification, used in sequence A, B, C, etc. (must specify when requesting WK²)

Arrangement	Adapter SAE Size	Drive Disc SAE Size
A	3	11-1/2
B	2	11-1/2
C	4	8
D	3	10
E	1	11-1/2
F	1	14
G	4	7-1/2
H	1	Delco
J	1/2	14
K	2	10
L	1/2	Delco
M	0	14
N	2	Small Delco
O	None	None
P	0	18
S	0	Delco
U	00	18
V	4	6-1/2
W	00	21
Y	4	10

Figure 2-1

Installation

3

Receiving Your MAGNAMAX^{DVR}® Generator

Upon receipt of the generator, it is recommended that it be carefully examined for possible damage incurred in shipment. The generator was given to the freight company in good condition, and they are responsible for the product from our dock to yours. Any damage should be noted on the freight bill before accepting the shipment. Claims for damage must be promptly filed with the freight company.

Unpacking and Handling

Read all instruction cards carefully. When lifting, attach an overhead crane to the lifting lugs on the generator frame. Apply lifting forces in a vertical direction.

⚠️ WARNING The lifting lugs on the generator are designed to support the generator only. Do not lift complete generator set by means of lifting lugs on generator. Personal injury or equipment damage may result.

Storage

In the event that the generator is not to be installed on the prime mover immediately, it is recommended that it be stored in a clean, dry area which is not subject to rapid changes in temperature and humidity. See Section 11 for more information.

Preparation for Use

Although the generator is carefully inspected and tested in operation before it leaves the factory, it is recommended that the unit be thoroughly inspected. The insulation on the wire should be inspected and all bolts should be checked for tightness.

Remove all shipping tapes, bags, blocks, and skids which are used to prevent vibration and rotor movement during shipment. Dry, low-pressure compressed air of approximately 30 psi (206 KPa) can be used to blow out the interior of the generator. In the case of two bearing machines, it is possible to turn the rotor by hand to make sure that it rotates smoothly without binding.

If the machine has been in storage for a year or longer, it is recommended that it be lubricated according to the lubrication instructions and chart found in Section 5.

If the machine has been exposed to damp, humid conditions, the insulation resistance should be checked. Refer to Section 8.

Generator Mounting – Single Bearing

Single bearing generators are provided with an SAE flywheel adapter and flexible drive discs. Very close tolerances are maintained in the manufacture of the generator so that the alignment procedure is extremely simple. A coupling hub of nodular iron is shrunk onto the shaft and special steel drive discs are bolted to the hub. Holes are provided in the periphery of the coupling disc which correspond to tapped holes in the flywheel. The outside diameter of the discs fits in a rabbet in the flywheel so that concentricity is assured in all cases.

⚠️ WARNING Do not apply any force to generator fan for lifting or rotating generator rotor. Disregarding these instructions may cause personal injury or equipment damage.

⚠️ CAUTION Grade 8 capscrews and heavy series lockwashers or grade 8 placebolts and hardened washers are recommended to mount the drive discs to the flywheel.

The SAE adapter and the flywheel housing are designed to match each other with no further alignment necessary. Shims may be necessary under the feet of the generator to insure a solid mounting. See Section 6 for more information.

Generator Mounting – Two Bearing

Two bearing generators are provided with a shaft extension and keyway. For direct-coupled units, the assembler furnishes a flexible coupling which is installed between the driver and the generator shaft.

Important: Aligning the two machines as accurately as possible will reduce the vibration, increase bearing life, and insure minimum coupling wear. It may be necessary to shim the generator feet for proper support and alignment. Consult the coupling manufacturer's instructions for alignment specifications and procedures.

Belt Drive

430 frame, two bearing generators can be belt driven. Please refer to Marathon Electric for application assistance involving belt driven installations. Sheave diameters should be chosen according to the table below.

MAGNAMAX^{DVR}® Sheave Application for Two Bearing Units ①

Model	Min. Sheave Dia. In Inches @ 10,000 Hr. B-10 Life ③		Min. Sheave Dia. In Inches @ 20,000 Hr. B-10 Life ③		Max. Sheave Width Inches
	60 Hz	50 Hz	60 Hz	50 Hz	
431RDL4005	13.0②	10.9	16.9②	14.2	8.5
431RDL4007	15.2②	13.3	19.8②	17.3②	8.5
432RDL4009	17.0②	14.8	22.5②	19.5②	8.5

① Assumptions:

- A. Belting factor is 1.3.
- B. The drive and the driven sheaves are the same diameter.
- C. The sheave load is located at the center of the shaft extension.
- D. Based upon continuous kW ratings.

- ② These sheave diameters exceed the maximum recommended belt speed of 6000 ft/min.
- ③ B-10 Life means 90% of the bearings will last this long or longer.

Environmental Considerations

Dirt, moisture, heat, and vibration are enemies of electrical equipment. Excessive exposure to the elements will shorten the life of the generator. The ambient temperature should not exceed the value shown on the generator nameplate. The MAGNAMAX^{DVR}® is built in a NEMA open type enclosure. Generators for outdoor application should be protected from the elements by housings with proper openings for ventilation. This protection should be designed to prevent the direct contact of wind driven rain, snow, or dust with the generator. In moist or humid areas, such as the tropics and marine service, additional protection is recommended. Although the standard windings are humidity and moisture resistant, special insulations and accessories such as space heaters can increase generator life significantly. In extremely dirty and dusty environments, a means of providing filtered cooling air to the generator is

recommended. When generators are marked , II, 3, G, T3, X they must be installed in a clean environment. If not possible, a means to providing filtered cooling air to the generator is mandatory for safe use. Refer to Marathon Electric for more information.

Electrical Connections

The generator conduit box construction allows conduit to enter the top, bottom, or either side of the box. A hole-saw or any suitable tool can be used to provide for the conduit entrance. Protect the interior of the generator from shavings when drilling or sawing. An approved connector must be used in conjunction with the conduit.

To minimize the transmission of vibration, it is essential that flexible conduit be used for all electrical entrance to the generator.

Refer to the connection diagram supplied with the generator and/or the proper diagrams shown in this section. Install all intercomponent and external wiring in accordance with the regulations of the national and local electrical codes. Clean all contact surfaces to assure good electrical bonding with the generator lugs or bus bars. Use heavy duty terminal lugs or good quality clamps for making all connections. Insulate all connections in accordance with national and local regulations.

Be sure the generator frame is grounded to all the other components of the system with a ground wire in accordance with national and local regulations.

Generator Lead Connections

The electrical connections in the conduit box should be made in accordance with the appropriate "connection diagram." Use the diagram appropriate for the number of leads and voltage range required. Refer to the drawings supplied with the generator and to drawings in this section.

The final voltage setting is established within the selected range by an adjustment of the voltage regulator.

 **CAUTION** Some generators have multiple, identically marked cables for each lead. Connect all identically marked cables together when making connections.

Installation

3

12 Lead High Wye

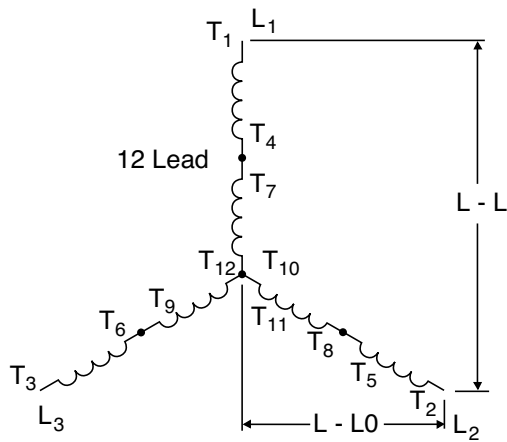

Twelve lead generators are dual voltage generators with six coils which don't have the connection of the three inner coils. There are 12 or 24 cables coming out of the generator.

Voltage		Connect	L ₁	L ₂	L ₃	L-L0	
							L-L
60 HZ	380	T ₁₀ T ₁₁ T ₁₂	T ₁	T ₂	T ₃	T ₁₀	
	416						
	440						T ₄ T ₇
	460						
50 HZ	480	T ₅ T ₈				T ₁₁	
	380	T ₆ T ₉				T ₁₂	
	400						
	416						

10 Lead High Wye

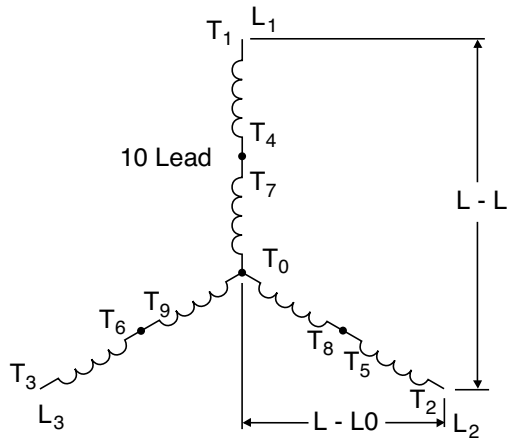

Ten lead generators are dual voltage generators with six coils. One end of the three inner coils is connected together. There are 10 or 20 cables coming out of the generator.

Voltage		Connect	L ₁	L ₂	L ₃	L-L0	
							L-L
60 HZ	380	T ₄ T ₇	T ₁	T ₂	T ₃	T ₀	
	416						
	440						T ₅ T ₈
	460						
50 HZ	480	T ₆ T ₉					
	380						
	400						
	416						

12 Lead Low Wye

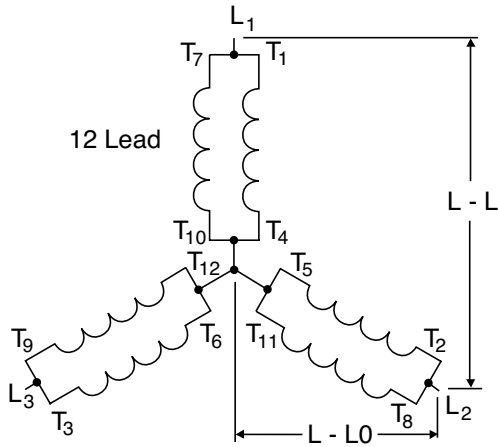

Twelve lead generators are dual voltage generators with six coils which don't have the connection of the three inner coils. There are 12 or 24 cables coming out of the generator.

		Voltage		Connect	L ₁	L ₂	L ₃	L-L0	
		L-L	L-L0						
60	HZ	190	110	T ₁₀ T ₁₁ T ₁₂	T ₁	T ₂	T ₃	T ₁₀	
		208	120						T ₄ T ₅ T ₆
		220	127	T ₁ T ₇				T ₁₂	
		230	133					T ₂ T ₈	T ₄
		240	139						T ₃ T ₉
50	HZ	190	110	T ₄ T ₅ T ₆ T ₀				T ₆	
		200	115					T ₀	
		208	120						

10 Lead Low Wye

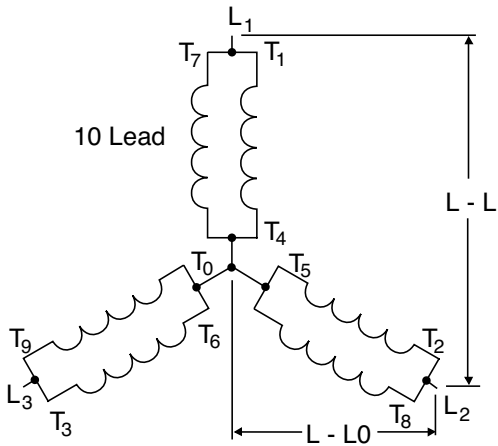

Ten lead generators are dual voltage generators with six coils. One end of the three inner coils is connected together. There are 10 or 20 cables coming out of the generator.

		Voltage		Connect	L ₁	L ₂	L ₃	L-L0	
		L-L	L-L0						
60	HZ	190	110	T ₁ T ₇	T ₁	T ₂	T ₃	T ₄	
		208	120						T ₂ T ₈
		220	127	T ₃ T ₉				T ₆	
		230	133					T ₄ T ₅ T ₆ T ₀	T ₀
		240	139						
50	HZ	190	110						
		200	115						
		208	120						

Installation

12 Lead High Delta

3

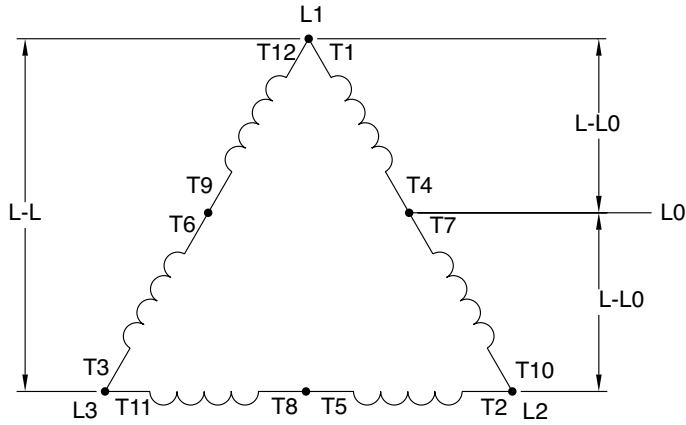

Delta connection with 12 lead generators only.

Voltage		Connect	L ₁	L ₂	L ₃
	L-L				
60 HZ	240	T ₄ T ₇	T ₁	T ₂	T ₃
	277	T ₅ T ₈			
50 HZ	200	T ₆ T ₉			
	220	T ₁ T ₁₂			
	240	T ₂ T ₁₀			
		T ₃ T ₁₁			

12 Lead Low Delta

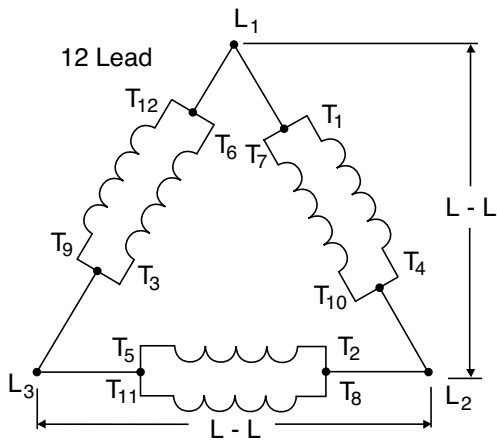

Delta connection with 12 lead generators only.

Voltage		Connect	L ₁	L ₂	L ₃
	L-L				
60 HZ	120	T ₁ T ₇ T ₆ T ₁₂	T ₁	T ₂	T ₃
	139	T ₂ T ₈ T ₄ T ₁₀			
50 HZ	100	T ₃ T ₉ T ₅ T ₁₁			
	120				

6 Lead Wye

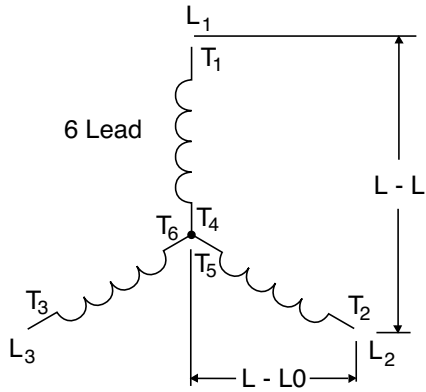

Six lead generators have 3 coil groups with 6 or 12 cables or bus bars coming out of the generator.

Voltage		Connect	L ₁	L ₂	L ₃	L-0	
	L-L L-LO						
60 HZ	190	T ₄ T ₅ T ₆	T ₁	T ₂	T ₃	T ₄ T ₅ T ₆	
	203						110
	220						120
	230						127
	240						133
	240						139
	3300	1905					
	4160	2400					
50 HZ	190						
	200						
	208						
	3300						

6 Lead Delta

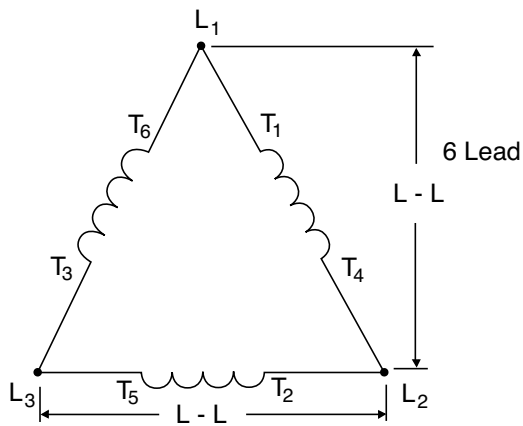

Six lead generators have 3 coil groups with 6 or 12 cables coming out of the generator.

Voltage		Connect	L ₁	L ₂	L ₃
	L-L				
60 HZ	2400	T ₁ T ₆	T ₁	T ₂	T ₃
		T ₂ T ₄			
50 HZ	1905	T ₃ T ₅			

Installation

4 Lead Wye

3

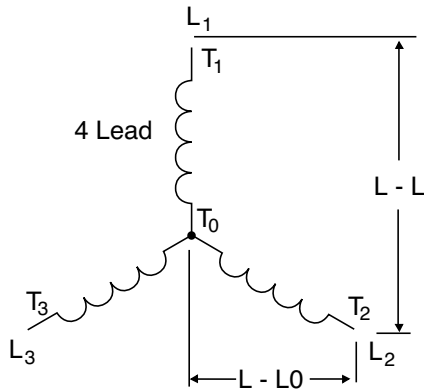

Four lead generators have 3 coil groups with one end of each group connected together. There are 4, 8, or 16 cables or 4 bus bars coming out of the generator.

		Voltage		L ₁	L ₂	L ₃	L-L0
		L-L	L-L0				
60 HZ		380	219	T ₁	T ₂	T ₃	T ₀
		416	240				
		440	254				
		460	266				
		480	277				
		600	346				
50 HZ		380	219				
		400	231				
		416	240				
		480	277				

3 Lead Delta

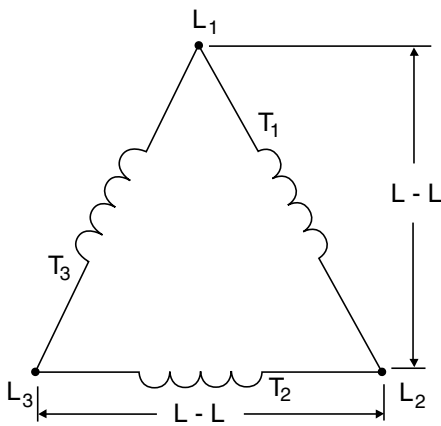

Three lead generators have 3 coil groups with one end of each group connected into a Delta internally. There are 3, 6, or 12 cables or 3 bus bars coming out of the generator.

		Voltage		
		L ₁	L ₂	L ₃
60 HZ		L-L		
		480		
		T ₁	T ₂	T ₃

12 Lead Zigzag

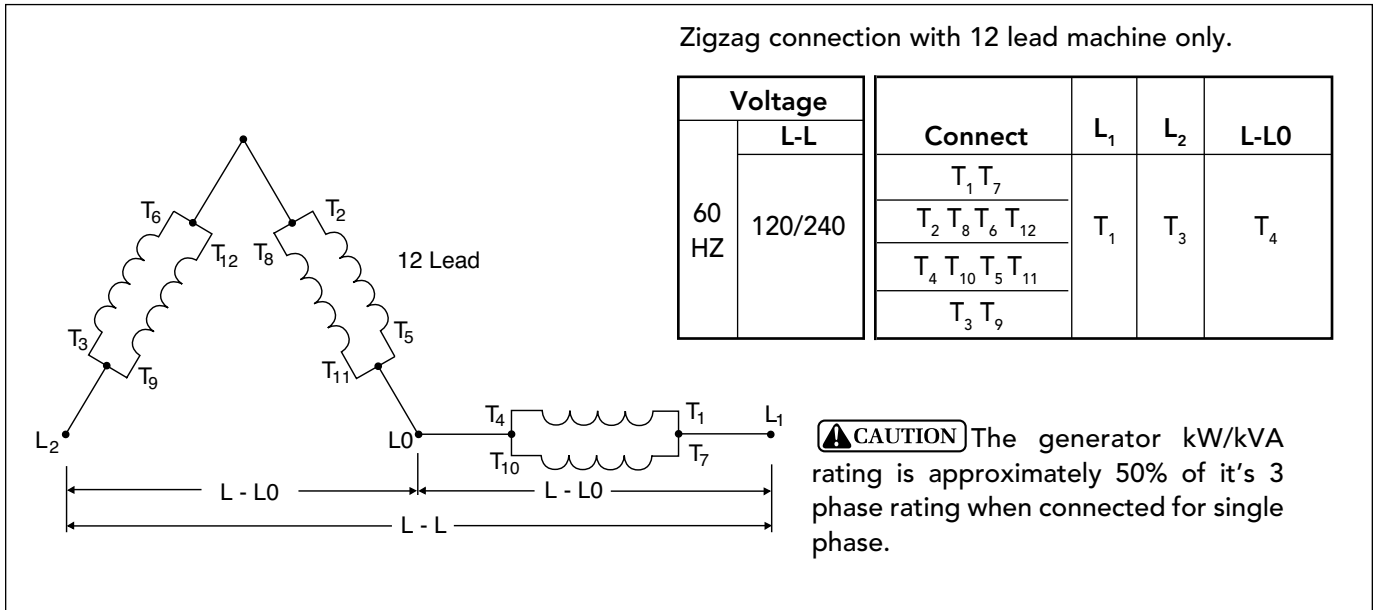

Typical System Diagram

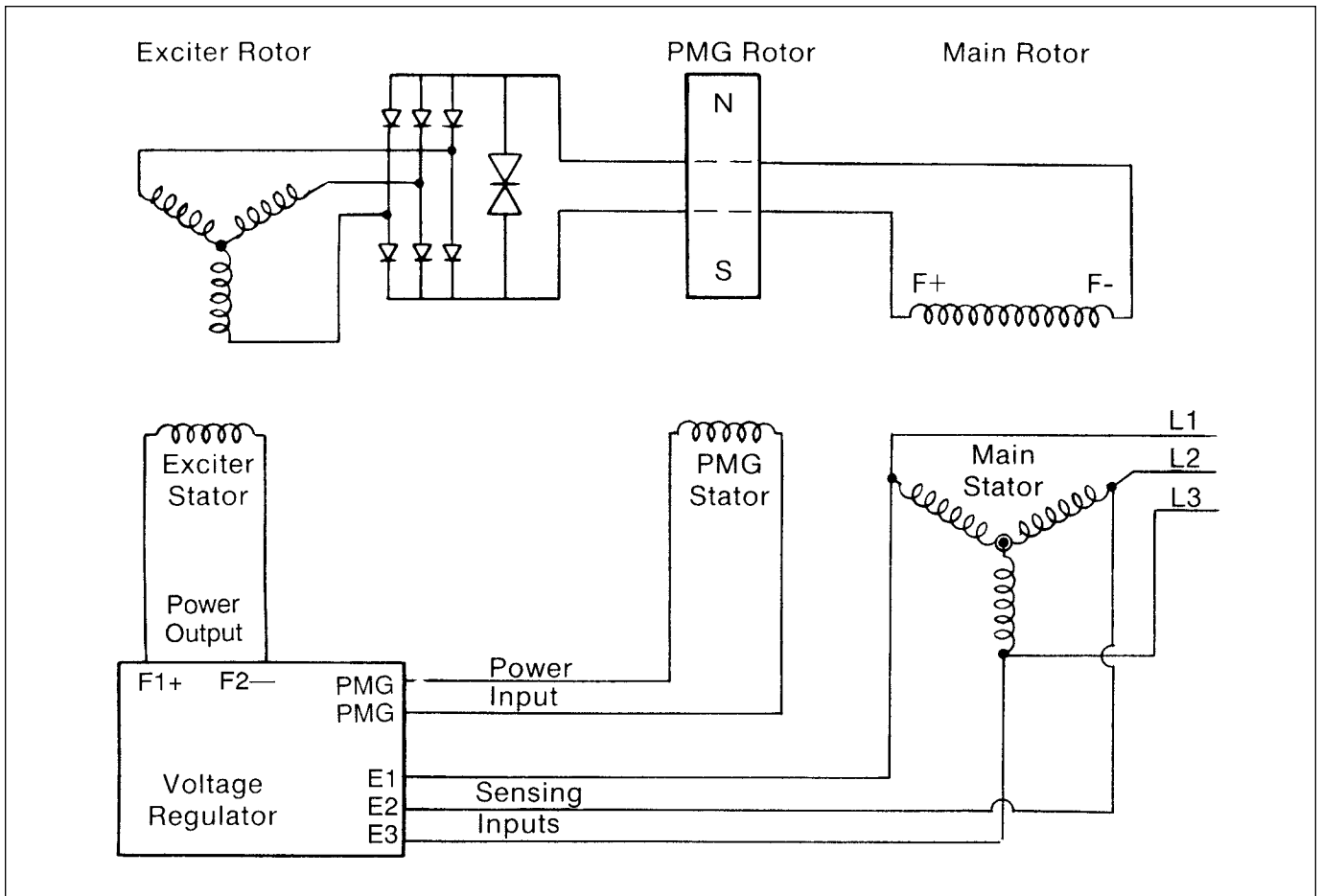

Installation

3

Paralleling Operations

MAGNAMAX^{DVR}® generators come standard with amortisseur windings die cast as an integral part of the rotor. This exclusive uni-rotor construction makes all MAGNAMAX^{DVR}® generators suitable for paralleling operations when the proper control equipment is added. Paralleling with other generator sets and/or with the utility power grid offers a number of advantages. Multiple unit installations increase power capacity; they can be added or removed from the line depending on the load requirements; they can be better maintained and repaired (since single source breakdown would mean total loss of power), and they often provide more reliable, efficient, and economical operation.

Successful parallel operation means that the generators deliver power to the external system without delivering power to each other, or accepting power from the load bus or power grid. Additional equipment is necessary to insure safe and successful operation.

Prime Mover

The prime mover provides the speed and torque which will be necessary to keep the machines in synchronized operation. The governor will directly control the watt or kW load and frequency of the unit. The prime mover speed is controlled by a governor. The governor must have special paralleling provisions to permit parallel operation with the other machines.

Voltage Regulator

The voltage regulator controls the generator output voltage and the reactive power supplied by the generator. When two or more AC generators operate in parallel, the voltage regulator must have paralleling provisions (either internally or external to the regulator) to allow the voltage regulator to control the reactive or VAR load while it is in parallel operation. A separate paralleling current transformer is required to sense the reactive current and signal the voltage regulator. This additional paralleling circuitry is absolutely necessary to control the reactive current flowing between the generator sets.

Switchgear

There are additional relays and breaker controls which are necessary to insure safe, trouble free operation of paralleled units. Reverse power relays monitor the direction of power flow to insure that the generator is delivering the power, not accepting it. These power relays control breakers, which are a means of connecting and disconnecting the generator from the load. The total system can include over-voltage, over-current protection, under frequency protection, power factor correction provision and various associated control equipment from manual switchgear to microprocessors. The amount of control gear and level of sophistication will be determined by the needs and requirements of the particular application.

Paralleling Basics

The following points are basic criteria which must be met before two units can be paralleled. THIS IS NOT MEANT TO BE SPECIFIC INSTRUCTIONS FOR PARALLELING OPERATION.

1. Additional paralleling circuitry
 - A. Voltage regulator-paralleling provisions
 - B. Paralleling current transformer(s)
 - C. Paralleling provisions on governor controls
 - D. Switchgear
2. The voltage and frequency must be the same for all sets with voltages in phase.
3. The voltage regulation characteristics of the individual generators should be similar.
4. The generators must have the same phase rotation.
5. The driving engines should have the same speed regulation characteristics and the governors should be adjusted to give the same speed regulation.

Before operating generator sets in parallel, each set should be checked by starting, operating, and adjusting the sets as individual units before attempting paralleling.

Reactive Load Control

When two identical generators are operating together in parallel and an unbalance occurs in field excitation, circulating currents begin to flow between

the generators. This current will appear as a lagging power factor or inductive load to the highly excited generator, and as a leading power factor or capacitive load to the generator with the lower field current. This is known as the reactive circulating current, and there are two methods of controlling it in parallel operation:

1. Reactive droop compensation (formerly known as parallel droop compensation) – the bus voltage droops, or decreases, as the reactive lagging power factor load is increased.
2. Reactive differential compensation (formerly known as cross current compensation) – the reactive differential compensation circuit allows parallel generators to share reactive loads with no decrease or droop in generator voltage. The circuit must meet the following criteria:
 - A. All paralleling current transformers for all the generators being paralleled must be included in the secondary interconnection loop.
 - B. When different size generators are paralleled, all paralleling current transformers must have the same or proportional ratios that give approximately the same secondary current.
 - C. Voltage regulator paralleling circuitry must be the same.
 - D. Current transformer secondaries and the generator lines must be isolated electrically.

Because of the preceding criteria, reactive differential compensation cannot be used when paralleling with the utility power grid. There is no limit, however, in the number of generators that can be included in this type of circuit.

- E. It is also desirable to have an auxiliary contact on the main generator breaker to short the parallel CT secondary when that breaker is open (not connected to the load bus).

Paralleling Circuitry

Because of the number of variables involved in paralleling generator sets, every installation will have its own circuitry and methods or procedure of

bringing paralleled units on line. There are numerous ways of connecting paralleled units and an almost unlimited variety of applications and associated equipment.

When parallel operation is desired, it is important that the control manufacturer, the generator manufacturer, and the systems engineer work together to insure the proper selection of all components. Please refer to Marathon Electric for application assistance.

Thyristor or SCR Loading

Solid state electronic control devices which utilize thyristors or SCR firing circuits (such as variable frequency induction motor controls, precision motor speed controls, no-break powered battery chargers, etc.) can introduce high frequency harmonics which adversely affect or destroy the normal waveform of the generator. This creates additional heat in the generator stator and rotor and can cause overheating. These devices can and do present problems to non-utility power generating equipment or any limited power bus system. The problems which can occur are not limited to the generator itself, but can effect the solid state control device, the equipment it controls, other associated loads, monitoring devices, or a number of combinations over the entire system.

MAGNAMAX^{DVR}® generators can supply power to thyristor or SCR loads when properly applied. When SCR loads are more than 25% of the total load, select the generator based on the 80°C R/R rating. The standard voltage regulator is PMG powered and senses 3 phase RMS voltages for maximum stability against severely distorted wave forms. SCR type applications such as cranes, shovels, etc., require special consideration of the generator insulation system due to greater dielectric stress and severe environmental conditions. It is important that the control manufacturer, the generator manufacturer, and the systems engineer work together to insure the proper selection of all components. Please refer to Marathon Electric for application assistance.

Operation

4

Pre-Start Inspection

Before operating the generator for the first time, the following checks are recommended:

1. A visual inspection should be made to check for any loose parts, connections, or foreign materials. Refer to section 8.
2. Check for clearance in the generator and exciter air gap. Be sure the generator set turns over freely. Bar the generator over by hand at least 2 revolutions to be sure there is no interference.

⚠️ WARNING Do not apply any force to generator fan when rotating generator rotor. Disregarding these instructions may cause personal injury or equipment damage.

3. Check all wiring against the proper connection diagrams and make sure all connections are properly insulated. Support and tie leads to keep them from being damaged by rotating parts or by chafing on sharp corners.
4. Be sure the equipment is properly grounded.
5. Inspect for any remaining packing materials and remove any loose debris, building materials, rags, etc., that could be drawn into the generator.
6. Check fasteners for tightness.
7. Check to be sure no tools or other hardware have been left inside or near the machine.
8. Install and check to be sure all covers and guards are in place and secure.

⚠️ WARNING Residual voltage is present at the generator leads and at the regulator panel connections, even with the regulator fuse removed. Caution must be observed or serious personal injury or death can result. Consult qualified personnel with any questions.

Starting Up the Generator

The following procedure should be followed for starting up the generator for the first time:

1. The generator output must be disconnected from the load. Be certain that the main circuit breaker is open.
2. Disable the voltage regulator by removing the fuse.

⚠️ WARNING Do not overspeed the generator. Excessive centrifugal forces could damage the rotating fields. Be prepared for an emergency shut-down.

3. Follow the manufacturer's instructions and start the prime mover. Check the speed and adjust the rpm shown on the generator nameplate.
4. Replace the regulator fuse and adjust the voltage to the required value (figure 4-2). Check all line to line and line to L0 voltages to be sure they are correct and balanced. If the voltages are not correct, shut down immediately and recheck all connections. See section 3.
5. Close the main circuit breaker and apply the load.
6. Monitor the generator output current to verify it is at or below nameplate amps.
7. Adjust engine speed at full load to 1800 rpm for 60 Hz, 1500 rpm for 50 Hz (refer to prime mover/governor instruction manuals).
8. Before stopping the engine, remove the load by tripping the main circuit breaker.

Voltage Adjustments

The generator output voltage is controlled by the voltage regulator. There is a cover to access the control panel on the side of the generator conduit box (figures 4-1 and 4-2). Refer to the regulator manual for detailed information. In cases where special or remote mounted regulators are used, refer to instructions supplied by the generator set assembler and to the voltage regulator manual.

Other Adjustments

Depending upon application, adjustments to other protective and control gear may be required. Refer to instructions supplied by the generator set manufacturer.

The standard MAGNAMAX^{DVR}® voltage regulator also has many protective and control circuits built in. Refer to the regulator manual for further details.

Field Flashing

The standard MAGNAMAX^{DVR}® generator is supplied with a PMG (permanent magnet generator). It will never require field flashing.

In rare cases where a special generator may be furnished without a PMG, refer to the factory for more detailed information. Include the complete generator model and serial number (see page 3).

Regulator Access

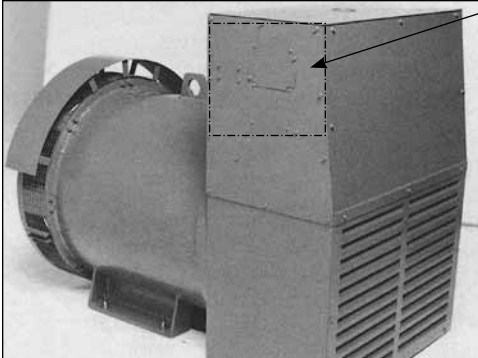

See Figure 4-2 for enhanced view of this area.

Figure 4-1

Standard Marathon Electric Regulator



Figure 4-2

Maintenance

Maintenance – General Information

Dirt, heat, moisture, and vibration are common enemies of a generator. Keeping the generator clean and dry, maintaining proper alignment of the generator and its prime mover, and preventing overloads will result in efficient operation and long life.

Generators that are outdoors should be protected from the elements by suitable houses or enclosures.

Dirt and dust will conduct electricity between points of different electrical potential. Moisture will aggravate the problem further. Insulation system failure can result if corrective action is not taken. The condition of the insulation system can be tested by measuring insulation resistance (see section 8 - Generator Testing).

Insulation resistance should be checked when putting the generator into service after it has been in storage and any time contamination by moisture and dirt is suspected. Normally, moisture buildup is not a problem when the generator is running since heat produced internally will tend to keep it dry. Moisture can collect in the generator when it is shut down. The problem will be worse in humid environments or in areas where extreme temperature changes cause condensation (dew) to form inside the generator. Space heaters, air filters, and premium insulation systems, such as our VPI process, should be considered in difficult environments.

Accumulations of dust and dirt not only contribute to insulation breakdown, but they can also increase temperature by restricting ventilation and by blocking the dissipation of heat. Some machines are exposed to accumulations of materials such as talc, lint, rock dust, or cement dust which may obstruct the ventilation. The most harmful type of foreign materials include carbon black, metallic dust and chips, and similar substances which not only impede the ventilation, but also form a conductive film over the insulation, increasing the possibility of insulation failure. Machines operating in dirty places should be disassembled and cleaned periodically.

Air Intake and Exhaust

Check the area around the air intake and exhaust openings to be sure they are clean and unobstructed. Remove all foreign material and clean all screens (figure 5-1).

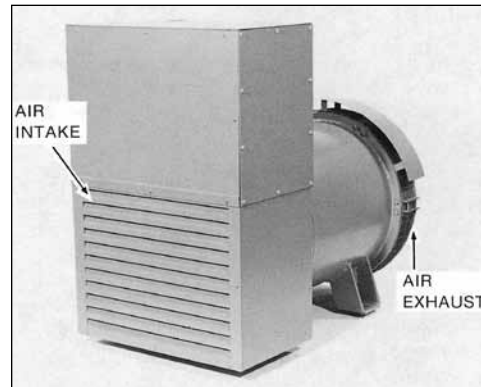

Figure 5-1

Electrical Connections and Windings

Inspect for loose or contaminated connections. Check wires for cracked or frayed insulation. Tighten connections and replace defective or oil-soaked insulation.

If inspection shows that varnish coatings on the windings have deteriorated, they should be recoated with insulating varnish. Please refer to Marathon Electric for insulation system requirements.

Lubrication

All generators are lubricated before leaving the factory and are ready for operation. As a general rule, bearings should be relubricated annually or at the indicated intervals in table 5-3, whichever occurs first. Unusually severe operating conditions, such as high ambient or dusty environments, require more frequent lubrication (every six months or one-half the table intervals, whichever occurs first).

Use Mobil® Polyrex® EM or equivalent anti-friction type, high quality grease with a lubrication temperature range of -22° to +350°F (-30° to +175°C).

During an overhaul, the grease reservoir should be thoroughly cleaned and new grease added. The reservoir should be 1/3 to 1/2 filled with new grease.

NOTE: Mobil and Polyrex are registered trademarks of Exxon Mobil Corporation or one of its subsidiaries.

Lubrication

CAUTION Follow the generator nameplate recommendations for grease interval and amount. Table 5-3 intervals and amounts are general guidelines.

CAUTION Generators are pre-greased with Mobil® Polyrex® EM NGLI 2 grease unless stated otherwise on the generator nameplate. Non-compatible lubricants can break down polyurea thickened grease and cause bearing failure. Compatible greases include, but are not limited to, Chevron® SRI, Shell® Gadus® S5 T100, Rykon® Premium EP NLGI 2, Texaco® Polystar® RB NLGI 2, and Shell® Oil Dolium R. Use only non-contaminated grease and prevent contamination while regreasing.

CAUTION Overgreasing bearings can cause premature bearing and/or generator failure. The quantity of grease added must be carefully controlled.

Generators are properly lubricated at the time of manufacture. It is not necessary to lubricate at the time of installation unless the generator has been in storage for a period of 12 months or longer.

Lubrication Procedure

1. Read CAUTION statements at left.
2. Stop generator and lock-out of service.
3. Remove contaminants from fill and drain plugs and surrounding area.
4. Remove fill and drain plugs. (Figure 5-2)
5. Check fill and drain holes for blockage and clean as necessary to allow unobstructed grease flow.
6. Insert 1/8" N.P.T. grease fitting in fill pipe.
7. Add proper type and amount of grease per generator nameplate or see Table 5-3
8. Start unit with drain plug removed. Allow unit to run 15 minutes to allow excess grease to drain.
9. Wipe off excess grease and replace fill and drain plugs. Generator is ready for operation.

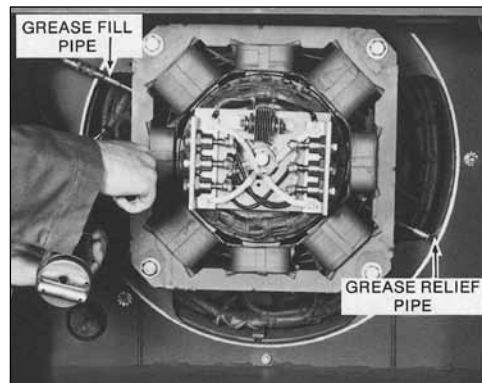

Figure 5-2

Table 5-3

Type	Frame Size	Bearing Size	Amount of Grease			Intervals ①	
			Ounces	Cubic Inches	Teaspoons	60 Hz	50 Hz
Single Bearing Units	431, 432 433	314	1.2	2.1	7.0	6500	8400
	571, 572 573, 574	316	1.5	2.6	8.3	5600	7200
	741, 742 743, 744	322	2.4	4.2	14.0	3000	4500
Double Bearing Units	431, 432 433	318	1.7	3.0	9.9	4600	6200
	571, 572 573, 574	318	1.7	3.0	9.9	4600	6200
	741, 742 743, 744	322	2.4	4.2	14.0	3000	4500

① Hours of running time or annually, whichever occurs first.

Maintenance

Drying Electrical Insulation

Electrical components must be dried before placing in operation if tests indicate that the insulation resistance is below a safe value (see section 8 – generator testing for test procedure).

Machines that have been idle for sometime in unheated and damp locations may have absorbed moisture. Sudden changes in temperature can cause condensation or the generator may have become wet by accident. Windings should be dried out thoroughly before being put into service. The following are recommended drying methods.

Space Heaters

Electric space heaters can be installed inside of the generator. When energized (from a power source other than the generator), they will heat and dry the inside of the generator. If an alternate source of electricity is not available, enclose the generator with a covering and insert heating units to raise the temperature 15–18°F (8–10°C) above the temperature outside of the enclosure. Leave a hole at the top of the enclosure to permit the escape of moisture.

Oven

Place the machine in an oven and bake it at a temperature not to exceed 194°F (90°C). The voltage regulator and any electronic component accessories must be removed from the generator when using this method.

Forced Air

A portable forced air heater can be used by directing heat into the air intake (conduit box) and running the generator with no load and without excitation (this can be accomplished by removing the regulator fuse). Heat at point of entry should not exceed 150°F (66°C).

“Short Circuit” Method

The generator can be dried out quickly and thoroughly by using this method.

⚠️ WARNING Be sure that all of the following steps are performed and all precautions taken as personal injury or serious damage to the generator could result.

1. Disconnect exciter leads F1 and F2 from the regulator.
2. Connect a battery or other DC power source of approximately 20–35 volts to the exciter leads F1 and F2. An adjustable voltage source is desirable, however a rheostat (rated approximately 2 amps) in series with the DC power source will work.
3. Short circuit the generator output lead wires to each other (L1 to L2 to L3). If using jumpers, be sure they are large enough to carry full load amperage.
4. Start the generator and measure the current through the output leads with a clip-on ammeter.
5. Adjust the voltage source to produce approximately 80% of the rated AC nameplate amps, but in no case exceed nameplate amps. If an adjustable source is not available and current is excessive, use a lower DC source voltage or a larger resistor in series with the source.

Running time will be determined by the amount of moisture present in the machine. Insulation resistance checks should be taken every one to four hours until a fairly constant value is obtained (see section 8 – Generator Testing for instructions on measuring insulation resistance).
6. After the generator is dry and the insulation resistance is brought up to specifications, remove the short circuit from the line leads, disconnect the DC source, and reconnect the F1 and F2 leads at the regulator. Be sure all connections are tight and correct before attempting to run the generator.

Cleaning Methods

When electrical components get dirty, the insulation must be cleaned. There are a number of acceptable methods for cleaning the generator, each of which will necessitate disassembly of the unit. The method of cleaning will be determined by the kind of dirt and when the unit must be returned to service. Drying after cleaning is necessary.

Whenever the generator is disassembled, the windings should be given a thorough inspection and the insulation cleaned, if necessary. The inspection should include the connection of the windings, insulation, and varnish coverage. Check the winding ties and coil supports. Look for any signs of coil movement or looseness and repair as required.

An electric motor repair shop in your area can normally assist with the proper cleaning of the generator windings. They may also be experienced in special problems (such as seacost, marine, oil rig, mining, etc.) that may be peculiar to a certain area.

Solvents

A solvent is usually required to remove accumulated soil containing oil or grease.

Only petroleum distillates should be used for cleaning electrical components.

Petroleum solvents of the safety type with a flash point greater than 100°F (38°C) are recommended.

CAUTION Winding varnishes are epoxy or polyester based. A solvent that does not attack these materials should be used.

WARNING Adequate ventilation must be available to avoid fire, explosion, and health hazards where solvents are used. Avoid breathing solvent vapors. Rubber gloves or other suitable protection for the hands should be used. Wear eye protection.

Apply the solvent with a soft brush or rag. Be careful not to damage the magnet wire or insulation on the windings.

Dry components thoroughly with moisture-free, low pressure compressed air.

Cloth and Compressed Air

Cleaning with a dry cloth may be satisfactory when components are small, the surfaces are accessible, and only dry dirt is removed.

Blowing dirt out with compressed air is usually effective particularly when the dirt has collected in places which cannot be reached with a cloth. Use clean dry air at 30 psi (206 KPa).

Brushing and Vacuum Cleaning

Dry dust and dirt may be removed by brushing with bristle brushes followed by vacuum cleaning. **Do not use wire brushes.** Vacuum cleaning is an effective and desirable method of removing dry and loose dirt.

Shell Blasting

Air blasting with ground nut shells may be satisfactory for removal of hard dirt deposits from insulation. Use mild abrasives such as 12–20 mesh ground walnut shells.

Steam Cleaning

If the generator is completely disassembled, including bearings and electronic components, steam cleaning of the major parts and windings is very effective. However, before the generator can be put back into service, the machine must be thoroughly dried in an oven to remove all moisture.

Removal from Prime Mover

⚠️WARNING Be sure all power is off before servicing. Failure to follow all safety instructions can result in serious personal injury or death.

Note: Before disconnecting any electrical wiring, be sure it is marked and can be identified for reinstallation. Remark as required.

1. Remove conduit box covers (figures 6-1 and 6-2).
2. Disconnect all external wiring from the generator leads (or bus bars) inside the conduit box.
3. Remove all conduit or ducting from the conduit box.
4. Attach a suitable hoist to the generator lifting lugs.
5.
 - a. For single bearing generators, remove the bolts mounting the screen assembly to the SAE adapter and remove the screen (figure 6-3). (**Note:** Do not remove the dripcover from the screen assembly if so equipped.) Remove the capscrews attaching the drive discs to the flywheel and remove the capscrews attaching the SAE adapter to the flywheel housing.
 - b. For two-bearing generators, disconnect the coupling or sheave and belts between the generator and prime mover (follow the coupling manufacturer's instructions for disconnection).

⚠️WARNING Do not apply any force to the generator fan for lifting or rotating the generator rotor. Disregarding these instructions may cause personal injury or equipment damage.

6. Remove the mounting bolts which secure the generator to the base. To make reinstallation easier, note the position of and save any shims that were used under the feet for alignment.
7. Raise the generator slightly and move the generator away from the prime mover. Raise or lower the generator to take pressure off of the drive discs so they slide easily out of the flywheel.
8. On single bearing generators, if generator is to be shipped, see Shipping Instructions (section 11) for proper rotor support.



Figure 6-1

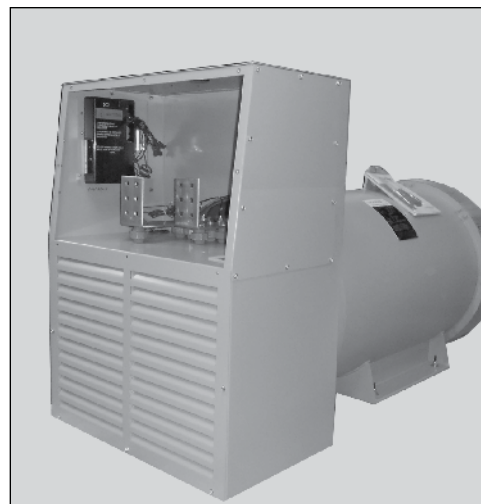

Figure 6-2

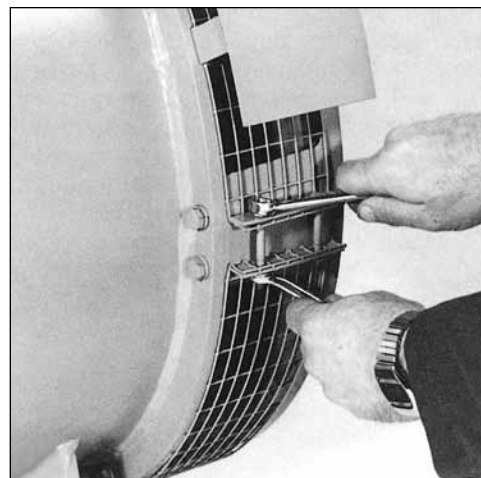

Figure 6-3

Conduit Box Removal

1. Note the location and markings (remark as required) and remove connections from voltage regulator, capacitor, and any other conduit box mounted control (figures 6-4 and 6-5).
2. On generators equipped with bus bars, mark all connections and disassemble main stator (power) leads from the generator side of the bus bars.
3. Remove bolts holding conduit box in place (figure 6-6).
4. Remove conduit box (figure 6-7).



Figure 6-6



Figure 6-4

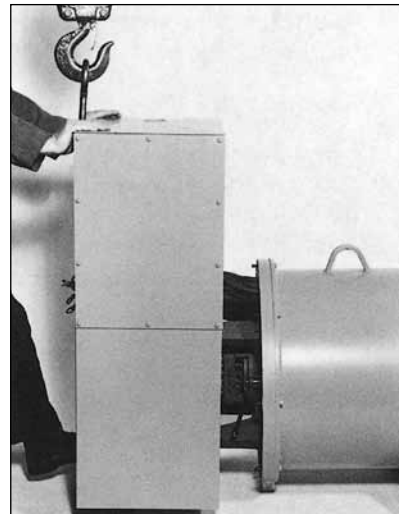

Figure 6-7

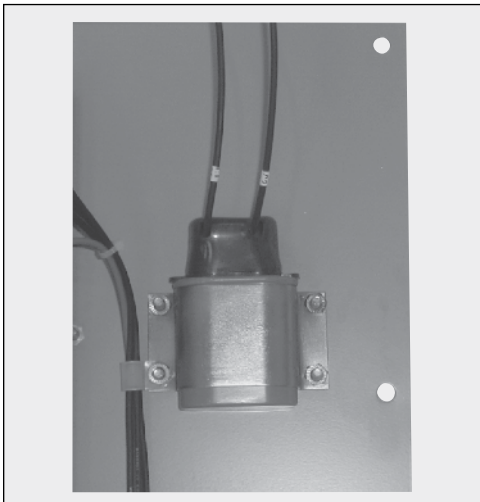

Figure 6-5

Exciter Stator (Field) Removal

1. Disconnect F1 and F2 leads from the corresponding F1 and F2 terminals on the regulator.
2. Remove all cable ties so the F1 and F2 leads can be removed with the exciter stator. Remove the four capscrews and belleville washers holding the exciter stator in place (figure 6-8). Remove the exciter stator using a lifting strap or fixture (figure 6-9).

Exciter Armature (Rotor) Removal

1. Note markings and disconnect the main rotor leads coming out of the aluminum standoff plate lead hole from the rectifier aluminum angle (figure 6-10).
2. Remove the capscrew and belleville washer which holds the exciter (rotor) armature to the generator shaft (figure 6-11).
3. Use a six inch, 7/8-14NF capscrew for a puller (see section 9). The hole that the mounting bolt goes through is threaded. Screw the puller bolt into the hole and it will push against the end of the shaft (figure 6-12). Carefully feed the main rotor leads through the hole as the exciter armature is removed (figure 6-13).

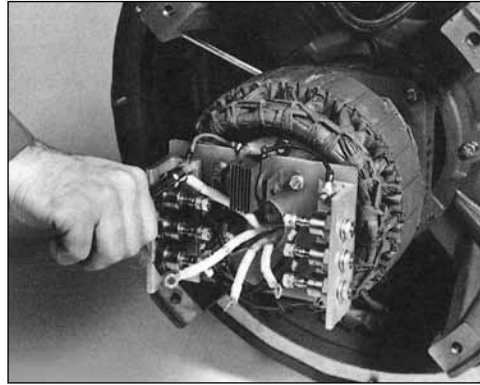

Figure 6-10

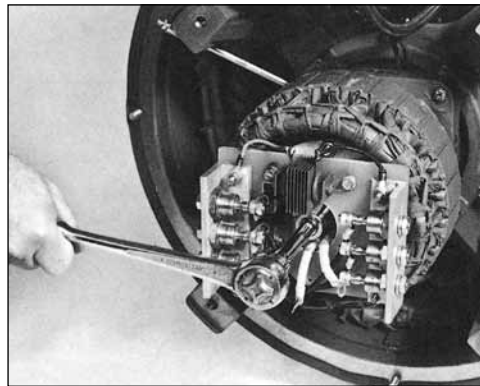

Figure 6-11

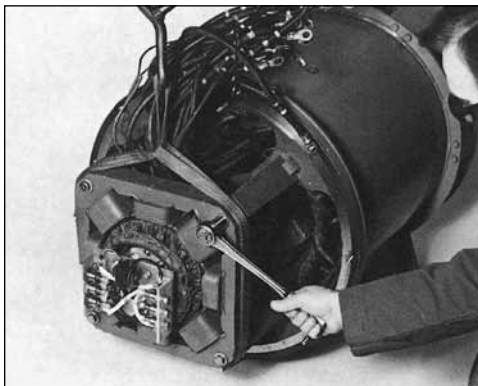

Figure 6-8

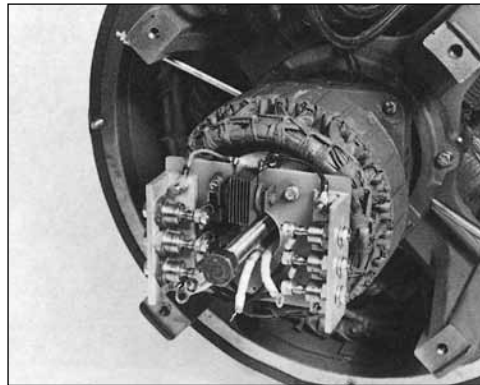

Figure 6-12

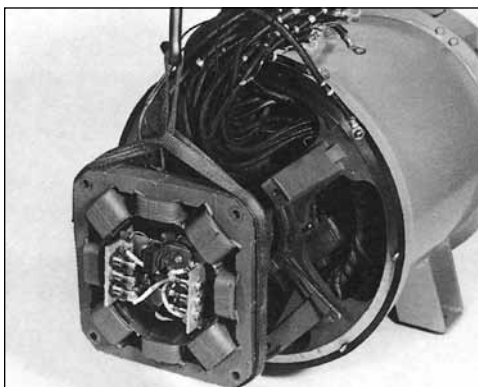

Figure 6-9

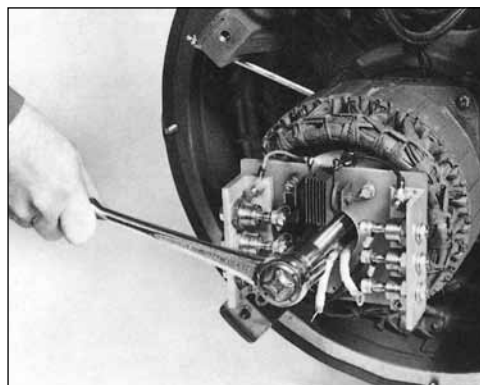

Figure 6-13

CAUTION Do not tighten the puller bolt beyond the end of the threads. If a bolt with sufficient thread length cannot be found, use a piece of threaded rod with a nut welded on the end.

PMG Stator Removal

1. Remove exciter armature (follow instructions found earlier in this section).
2. Remove the PMG output leads from the capacitor (figure 6-14) and loosen all cable ties so the leads can be removed with the PMG stator.
3. Note the position of the PMG stator leads which exit at the left inboard side or mark the stator so it can be reinstalled in the same position.
4. Remove the four mounting capscrews (see figure 6-15).
5. Carefully remove the PMG stator from its mounting pads and slide over the PMG rotor. The magnets used in the PMG are very strong. They will resist removal of the PMG stator (figure 6-16).

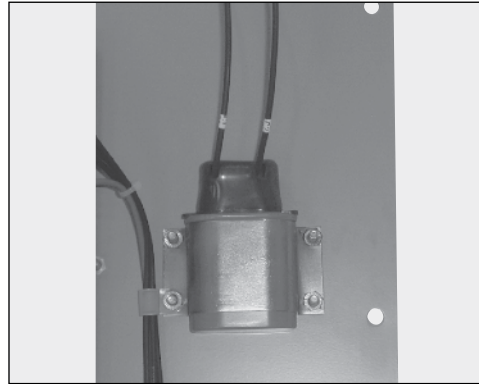

Figure 6-14

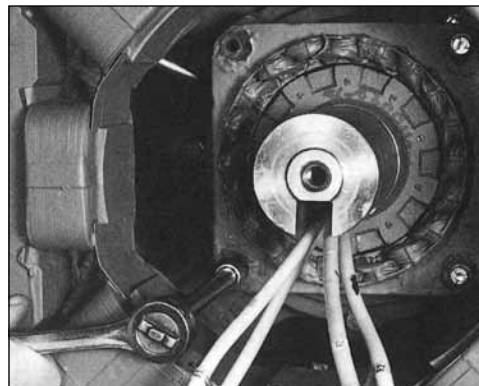

Figure 6-15

PMG Rotor Removal

1. Remove the exciter armature and PMG stator (follow instructions found earlier in this section).
2. Remove the snap ring which holds the PMG rotor in place on the shaft (figures 6-17 and 6-18).

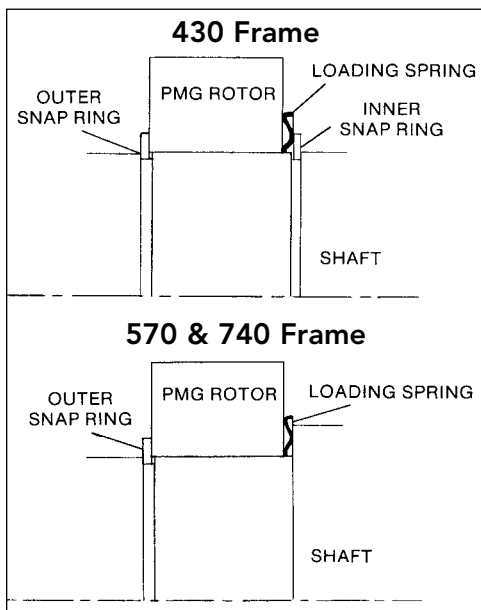

Figure 6-18



Figure 6-16

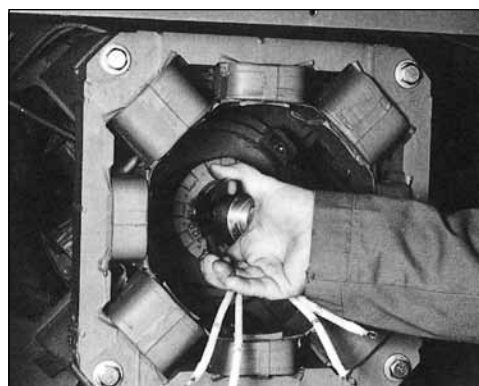

Figure 6-17

3. Slide the PMG rotor off of the shaft (figure 6-19).
4. Remove the loading spring (if the loading spring is not on the shaft, check to see if it is stuck on the back of the PMG rotor).
5. On 430 frame generators, a second snap ring is used inboard of the PMG rotor (larger generators have a step on the shaft). This snap ring must be removed before the generator's main rotor can be removed (figure 6-20).



Figure 6-20

Main Rotor Removal

1. Remove the exciter armature and PMG (follow instructions found earlier in this section).
2. a. For single bearing generators, remove the four capscrews holding the bearing caps to the front end bracket (figure 6-21). Remove the outer cap (figure 6-22).
- b. For two-bearing generators, remove the drive coupling or sheave and key from the shaft extension. Remove the four capscrews holding the bearing lock to the drive end bracket (figure 6-23). Remove the four capscrews holding the bearing caps to the front end bracket (figure 6-21). Remove the outer cap (figure 6-22).

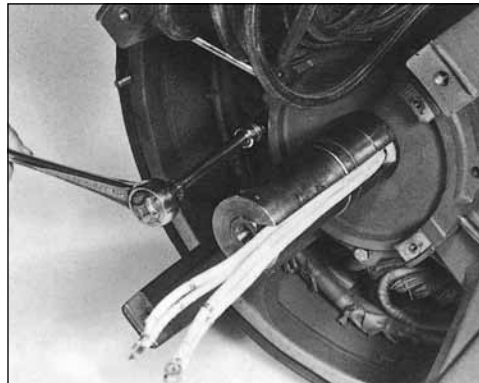

Figure 6-21

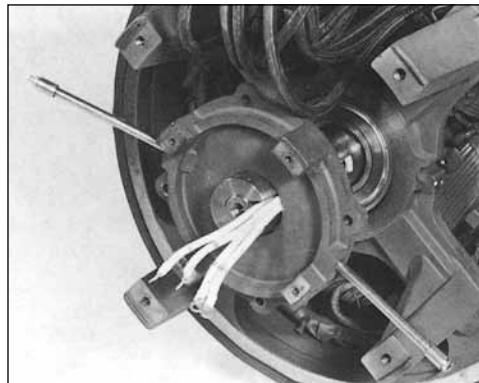

Figure 6-22



Figure 6-19



Figure 6-23

3. If the screen assembly is still mounted, remove the bolts securing the screen assembly to the drive end bracket or the SAE adapter and remove the screen assembly (figure 6-24). (**Note:** Do not remove the drip cover from the screen assembly if so equipped).
4. For single bearing generators, remove the capscrews and hardened washers holding the drive discs to the drive hub (figure 6-25). Remove all drive discs (and spacers, if any).
5. a. For single bearing generators, remove the capscrews holding the SAE adapter to the generator and remove the adapter (figures 6-26 and 6-27).
b. For two-bearing generators, remove the capscrews holding the drive end bracket to the generator and remove the bracket (figures 6-26 and 6-28).



Figure 6-26

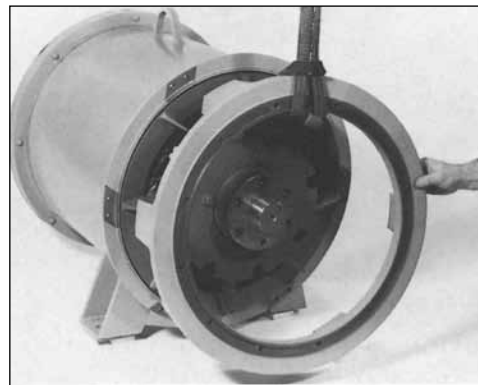

Figure 6-27

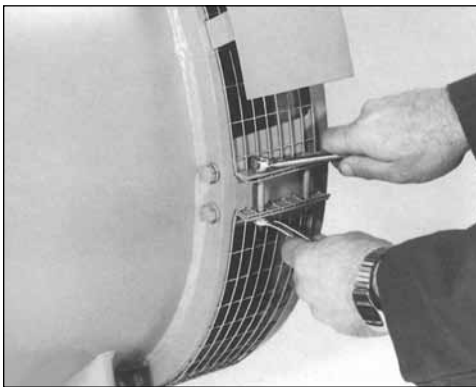

Figure 6-24



Figure 6-25

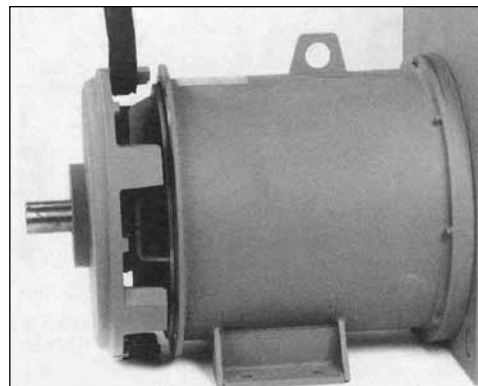

Figure 6-28

Service

CAUTION On large generators, a hoist and lifting strap should be used to assist in drive end bracket or SAE adaptor removal.

6. Using a rotor lifting fixture and a suitable hoist, carefully remove the rotor assembly from the main stator and frame assembly through the drive end (figure 6-29).

CAUTION Special care should be taken when removing the main rotor, winding damage could result if the rotor is allowed to hit the main stator.

WARNING Do not apply any force to the generator fan for lifting or rotating the generator rotor. Disregarding these instructions may cause personal injury or equipment damage.

Front End Bracket Removal

1. Remove front bracket mounting screws (figure 6-30).
2. Remove the front end bracket from the main stator assembly (figure 6-31).

CAUTION On large generators, a hoist and lifting strap should be used to assist in the front end bracket removal.

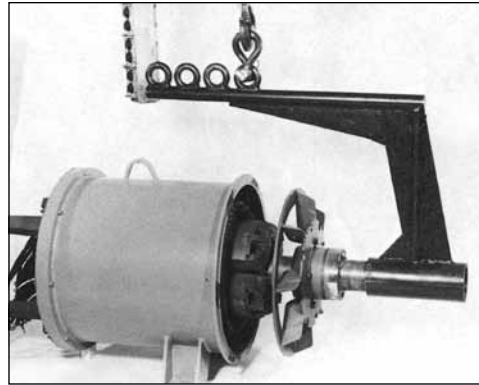

Figure 6-29

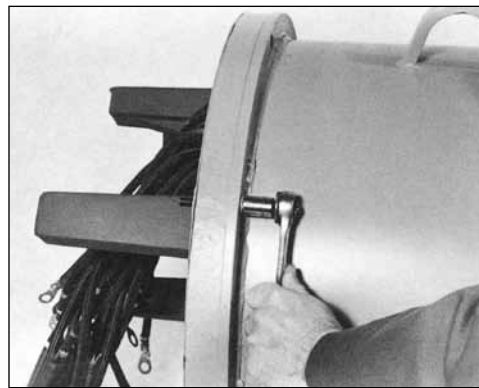

Figure 6-30

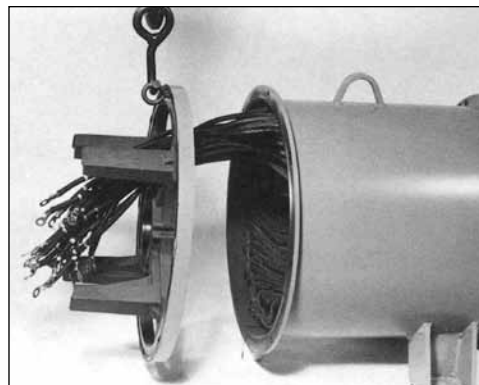

Figure 6-31

Exciter Inspection

A. Exciter Stator

1. Clean dust and dirt from the stator winding (see figure 6-32 and section 5).
2. Check the exciter stator for a loose, frayed, or burnt winding. Measure winding resistance and insulation resistance (see section 8). Repair or replace as necessary. If field repair of the winding is necessary, contact Marathon Electric for special winding procedures and materials.
3. Look for score marks in the bore of the exciter core caused by rubbing (this could indicate bearing or assembly problems and should be investigated).

B. Exciter (Rotor) Armature

1. Clean dust and dirt from the exciter armature and rectifier assembly (see figure 6-32 and section 5).
2. Check the exciter armature for burrs on the mating surfaces.
3. Check the rectifiers and surge protector for proper operation (see section 8). Replace defective parts.

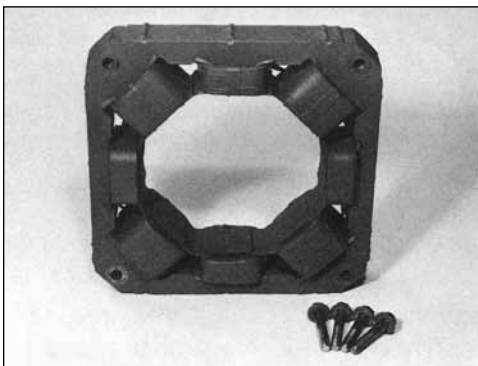

Figure 6-32

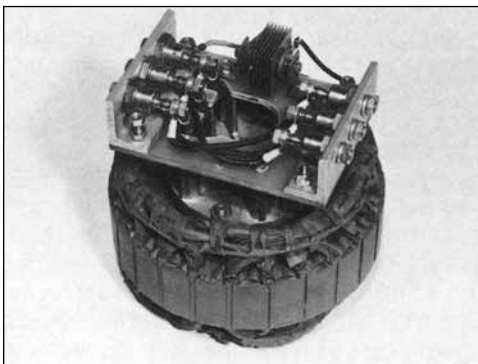

Figure 6-33

CAUTION Three forward polarity and three reverse polarity diodes are used. Be sure you have the correct part installed in the correct location. The surge suppressor is polarized. Observe polarity markings when changing the surge suppressor (figure 6-34).

Torque mounting nuts to 80 in-lb.

Torque lead terminal nuts to 25 in-lb.

Never torque against the diode terminal – use a 7/16 inch wrench to support the terminal (figure 6-35).

4. Check the exciter armature and rectifier assembly for a loose, frayed, or burnt winding or loose connections. Measure winding resistance and insulation resistance (see section 8). DO NOT megger diodes or surge suppressor. Repair or replace as necessary. If field repair of the winding is necessary, contact Marathon Electric for special winding procedures and materials.
5. Look for score marks on the outside diameter of the armature core caused by rubbing (this could indicate bearing or assembly problems and should be investigated).

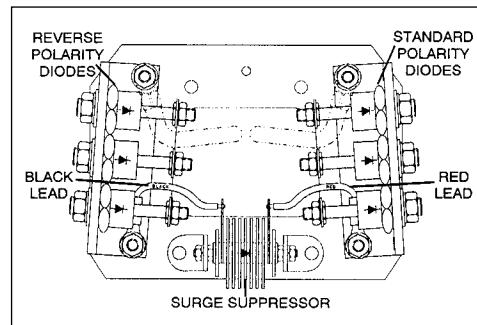

Figure 6-34

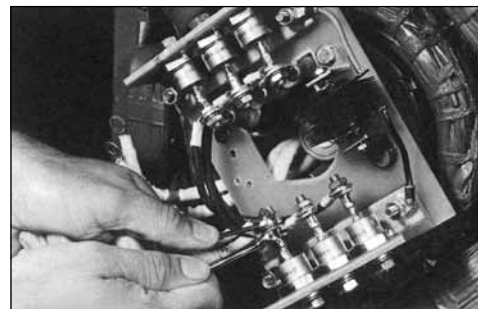

Figure 6-35

PMG Inspection

A. PMG Stator (figure 6-36)

1. Clean dust and dirt from the PMG stator winding (see section 5).
2. Check PMG stator for a loose, frayed, or burnt winding. Measure winding resistance and insulation resistance (see section 8). Repair or replace as necessary. Contact Marathon Electric for special winding procedures and materials.
3. Look for score marks in the bore caused by rubbing (this could indicate bearing or assembly problems and should be investigated).

B. PMG Rotor (figure 6-37)

⚠ WARNING The PMG rotor uses very strong magnets. Keep away from iron and steel parts that could be drawn to the magnets. Keep away from other components that can be damaged by strong magnetic fields.

1. Clean dust and dirt from the PMG rotor (see section 5).
2. Check to be sure all magnets are tightly bonded to the PMG rotor.
3. Check for burrs or corrosion in the bore and keyway where the rotor mounts to the shaft.
4. Look for score marks on the outside diameter caused by rubbing (this could indicate bearing or assembly problems and should be investigated).
5. Inspect snap rings and loading spring; replace as required.

Main Rotor Inspection

A. Bearing

1. Check the bearing for damage or wear. Clean the old grease from the bearing cap, and fill the bearing cap grease cavity 1/3 to 1/2 full of new Mobil® Polyrex® EM (or equivalent-see page 17).

⚠ CAUTION If the bearing needs to be removed for any reason, always install a new bearing.

2. If the bearing is to be replaced, remove with a suitable puller (figure 6-38).
3. **Be sure the inner bearing cap is on the shaft before installing the new bearing.**
4. Heat the new bearing in an oven to a maximum temperature of 212°F (100°C). Apply a thin coat of clean lubricating oil to the press-fit area of the rotor shaft. Using suitable heat resistant gloves, install the bearing over the end of the shaft until it seats against the shaft shoulder (figure 6-39). The bearing should slide on the shaft and be seated without excessive force. If the bearing binds on the shaft before being fully seated, a piece of tubing, slightly larger than the press-fit area, can be used to drive the bearing into place. Using light taps with a soft mallet, apply pressure to the inner race only.

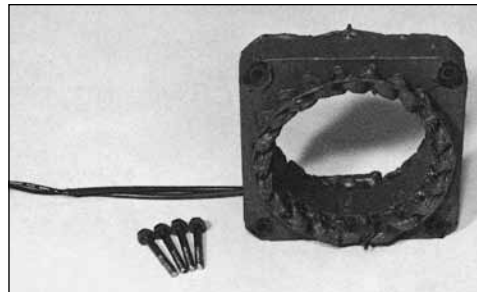

Figure 6-36



Figure 6-37

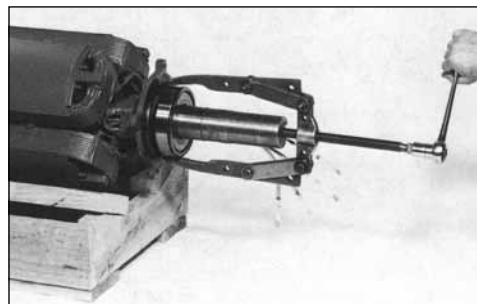

Figure 6-38

NOTE: Mobil and Polyrex are registered trademarks of Exxon Mobil Corporation or one of its subsidiaries.

CAUTION Under no circumstances should pressure be applied to the outer race of the bearing, as permanent bearing damage could result.

Allow the bearing to cool for one hour before attempting to assemble the generator.

B. Fan

1. Check the fan for cracks or broken blades. Replace the fan if defective.
2. Mark the hub and fan for alignment. This is necessary to be sure the balance weights will be in the same position when the fan is reinstalled.
3.
 - a. For single bearing generators, remove the fan mounting capscrews (figure 6-40) and slide the fan off the shaft (figure 6-41).
 - b. For two-bearing generators, remove the drive end bearing and bearing cap (see bearing removal instructions). Remove the fan mounting capscrews and slide fan off the shaft (figure 6-40 & 6-41).
4. To install, slide the fan on the shaft making sure the fan mounting surface is toward the drive hub. Align reference marks (this is important for assembly balance) and mount the fan to the drive hub with the capscrews and belleville washers (figure 6-42). Torque the capscrews to 60 ft-lb (81 N-m).
5. **Note:** Balance weights on the fan are for balance of the complete rotor assembly. The rotor assembly should be rebalanced if a new fan has been installed.
6. On two-bearing generators, install bearing cap and new bearing according to the bearing assembly instructions (Item A).

C. Drive Hub (Single Bearing Generators Only)

1. Check the drive hub for cracks or stripped drive disc mounting holes. Replace the hub if defective.



Figure 6-39

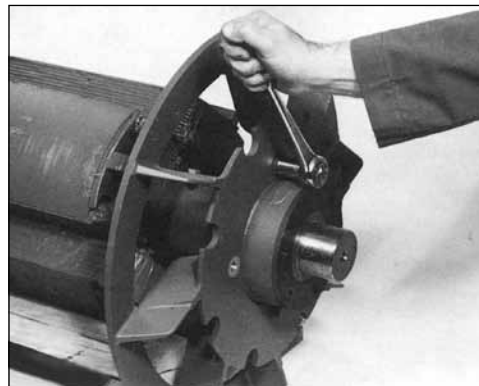

Figure 6-40

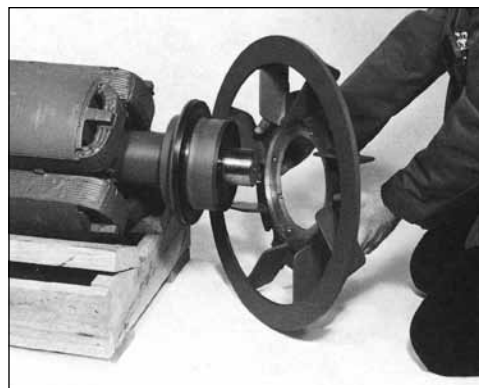

Figure 6-41

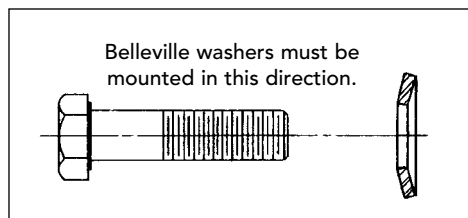

Figure 6-42

- If the hub is to be replaced, remove the fan (see Item B) and install a suitable puller to the hub. Remove the two setscrews in the hub over the key. Using a torch, rapidly heat the hub at the outer diameter while tightening the puller (this must be done rapidly before the heat can expand the shaft). Remove the hub (figure 6-43).
- To insure proper fan location, mark the new hub in the same place as the old hub relative to the keyway. Install key in shaft. Heat the new hub in an oven to 500-600°F (260-316°C). Using suitable heat resistant gloves, slide the hub over the key in the shaft until it seats against the shaft shoulder (figure 6-44).
- Allow the hub to cool for one hour. After the hub has cooled, tighten the setscrews in the hub to 50 ft-lb (68 N-m) torque. Match the alignment marks on the fan and hub and mount the fan (see Item B).
- Rebalancing the rotor assembly is not necessary if only the hub is replaced and the fan is mounted in the same location relative to the hub and shaft.

D. Main Rotor Core and Windings

- Clean all parts. Remove dust and dirt from the rotor windings (see section 5).

Remove any accumulated dust or dirt in the winding air passages with a piece of wire or with low-pressure, moisture-free air (figure 6-45).

CAUTION If a piece of wire is used for cleaning the air passages, care must be taken not to scratch the winding as this could cause an insulation failure.

- Check the rotor for loose, frayed, or burnt windings. Measure winding resistance and insulation resistance (see section 8). Test for shorted turns using an AC impedance test (see section 8). A defective rotor winding must be rewound by Marathon Electric. The rotor assembly must be rebalanced after any rework or repair has been completed.

E. Drive Discs (Single Bearing Generators Only)

- Inspect the drive discs for distorted or bent edges (figure 6-46). Inspect for worn mounting holes. Replace all defective discs as necessary.
- Inspect the drive disc mounting capscrews for damaged threads. Replace capscrews if damaged.



Figure 6-43



Figure 6-44

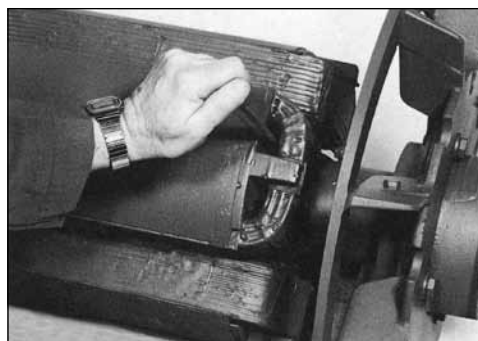

Figure 6-45

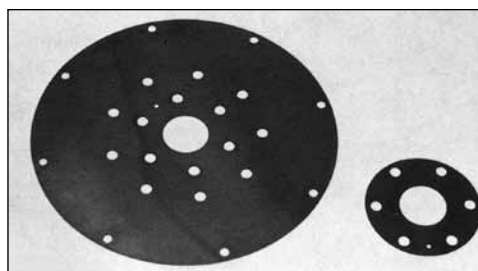

Figure 6-46

Front (Exciter) End Bracket Inspection

1. Remove the filler and drain grease pipes and the grease plugs from outer bearing cap (figure 6-47).
2. Clean the end bracket, outer bearing cap, grease pipes, and capscrews to remove all dust, dirt, and grease.
3. Inspect the capscrews for stripped threads and replace if defective.
4. Inspect the end bracket for stripped threads, cracks, and burred or rough mating surfaces. Inspect the bearing bore for burrs or wear. If the bracket shows excessive bearing bore wear, it should be repaired or replaced (figure 6-48).
5. Inspect the mounting pads for the PMG stator and exciter stator. Be sure they are smooth, clean, and free of any burrs or rust that could interfere with proper alignment (figures 6-47 and 6-48).
6. Reassemble the grease pipes and fittings to the bearing cap.

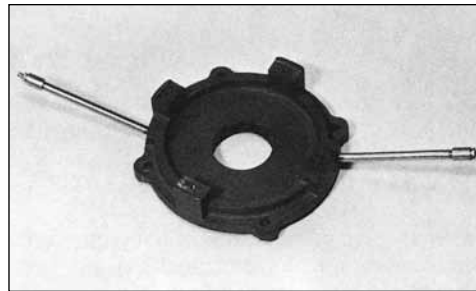

Figure 6-47

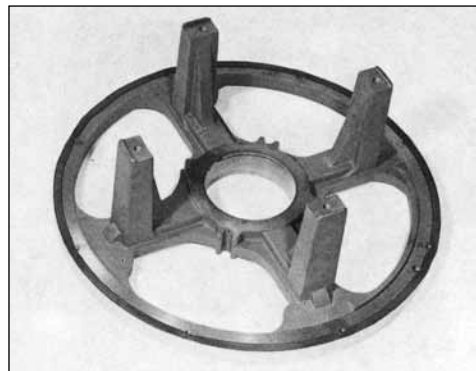

Figure 6-48

Drive End Bracket or SAE Adapter Inspection

1. For two-bearing generators, remove the grease plugs from the bracket.
2. Clean the bracket or adapter, capscrews, and screen assembly to remove all dust, dirt, and grease.
3. Inspect the capscrews for stripped threads and replace if defective.
4. Inspect the bracket or adapter for stripped threads, cracks, and burred or rough mating surfaces (figures 6-49 and 6-50).
5. For two-bearing generators, inspect the bearing bore for burrs or wear. If the drive end bracket shows excessive bearing bore wear, it should be repaired or replaced.

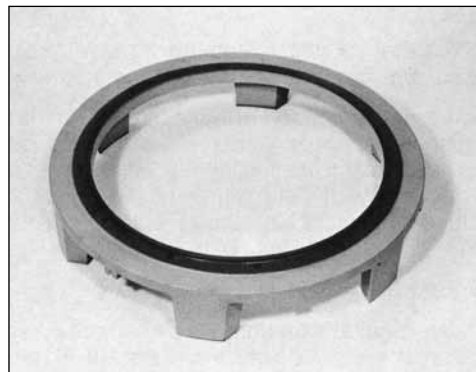

Figure 6-49

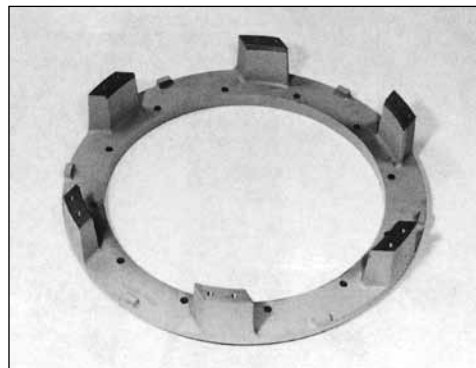

Figure 6-50

Main Stator Inspection

1. Clean dust and dirt from the stator frame and winding (see figure 6-51 and section 5).
2. Inspect the frame for stripped threads, cracks, burred mating surfaces, or other damage.
3. Inspect the stator for a loose, frayed, or burnt winding. Measure winding resistance and insulation resistance (see section 8). Repair or replace as necessary. If field repair of the winding is necessary, contact Marathon Electric for winding data.

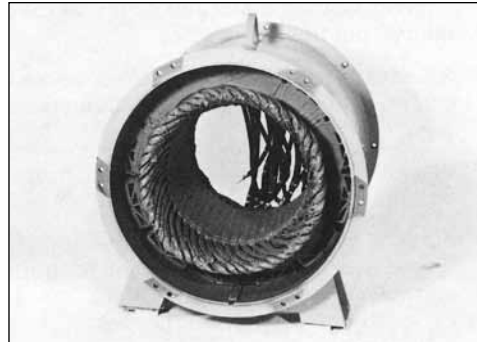

Figure 6-51

Front End Bracket Installation

1. Install two guide pins (threaded rod can be used) into the generator side of the end bracket mounting holes. Align the guide pins with the holes in the generator frame and slide the bracket onto the frame (figure 6-52). Install bracket mounting capscrews (figure 6-53).

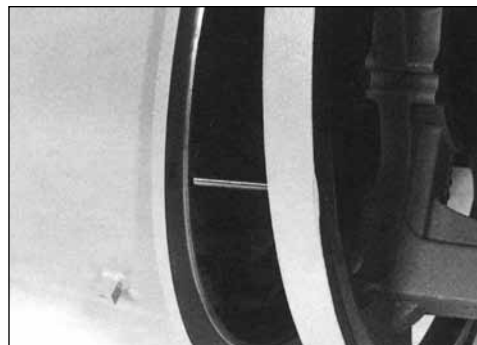

Figure 6-52

CAUTION On large generators, a hoist and lifting strap should be used to assist in the front end bracket installation.

2. Remove the two guide pins and insert the remaining capscrews and torque to specifications given in section 12.



Figure 6-53

Main Rotor Installation

1. Grease bearing cavity and bearing with Mobil® Polyrex® EM grease (or equivalent - see page 17).
2. Using a rotor lifting fixture and a suitable hoist, carefully install the rotor assembly into the main stator assembly through the drive end (figure 6-54). Carefully feed the rotor leads through the front end bracket shaft hole as the rotor is installed.

CAUTION Special care should be taken when installing the rotor assembly. Winding damage could result if the rotor is allowed to hit the main stator.

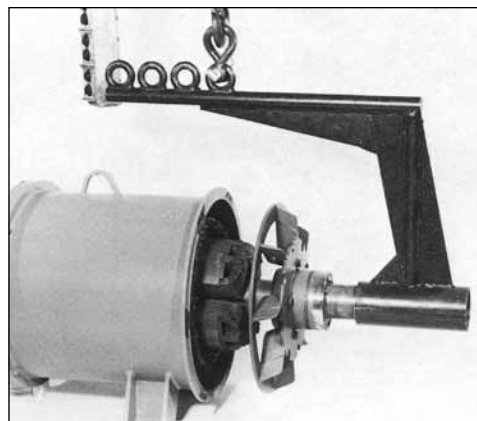

Figure 6-54

NOTE: Mobil and Polyrex are registered trademarks of Exxon Mobil Corporation or one of its subsidiaries.

⚠️ WARNING Do not apply any force to the generator fan for lifting or rotating the generator rotor. Disregarding these instructions may cause personal injury or equipment damage.

3. a. For single bearing generators, slide the SAE adapter over the fan and secure to the main stator and frame assembly with capscrews torqued per section 12 (figures 6-55 and 6-56). It may be necessary to raise the rotor assembly slightly to allow the mounting of the SAE adapter.
- b. For two-bearing generators, insert two guide pins in the rear bearing lock holes (figure 6-57). Fill the grease cavity of the drive end bracket 1/3 to 1/2 full of Mobil® Polyrex® EM grease (or equivalent - see page 17). Assemble all grease plugs in the bracket. Mount the bracket on the bearing and guide the bearing lock pins through the bracket holes (figure 6-58). Align the drive end bracket and mount with the capscrews (figure 6-59). Insert two capscrews with lockwashers into the bearing lock and tighten. Remove the guide pins and replace with the remaining two capscrews with lock washers. Torque bearing capscrews to 25 ft-lb (34 N-m). Torque bracket mounting capscrews per specifications given in section 12.

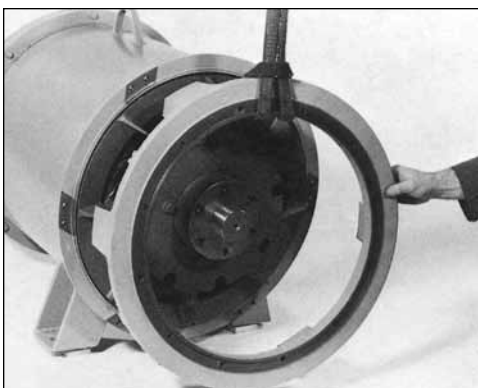

Figure 6-55

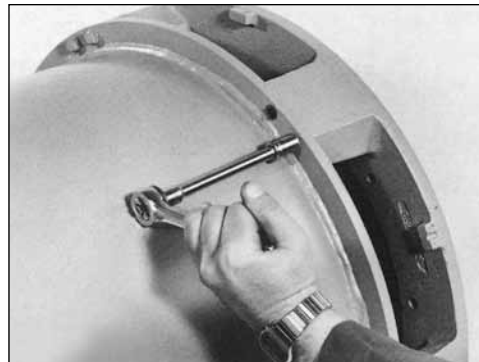

Figure 6-56

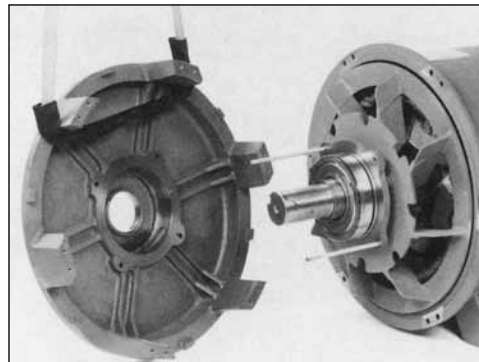

Figure 6-57

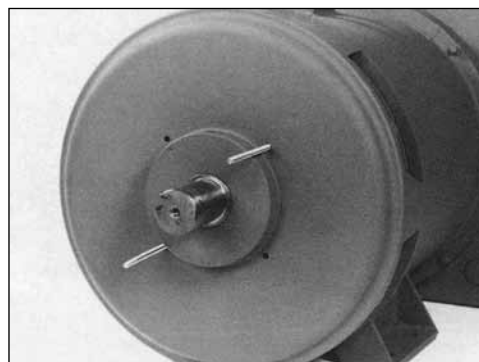

Figure 6-58



Figure 6-59

NOTE: Mobil and Polyrex are registered trademarks of Exxon Mobil Corporation or one of its subsidiaries.

Service

CAUTION On large generators, a hoist and lifting strap should be used to assist in the drive end bracket or the SAE adapter assembly.

4. a. For single bearing generators, insert a guide stud into the drive hub. Position all spacers (if any), then all drive discs, one at a time until all discs are installed (figure 6-61). Make sure that all disc mounting holes at the inner and outer diameter are properly aligned. Secure the discs with the grade 8 5/8-18 capscrews and hardened washers. Torque to 192 ft-lb (260 N-m) (see figure 6-62 for torquing sequence).
5. Install the outer bearing cap on the exciter end (figure 6-63). Align holes in inner and outer bearing cap and install cap screws. Torque to 25 ft-lb (34 N-m) – see figure 6-64.

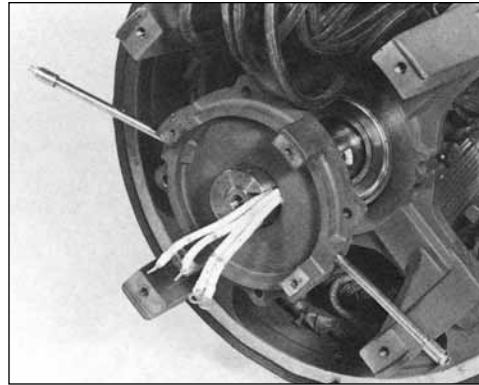

Figure 6-63

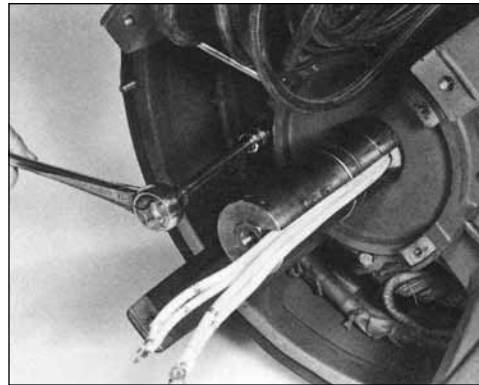

Figure 6-64

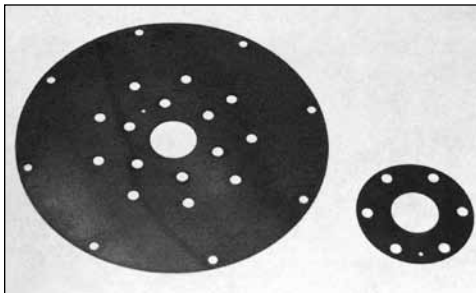

Figure 6-61

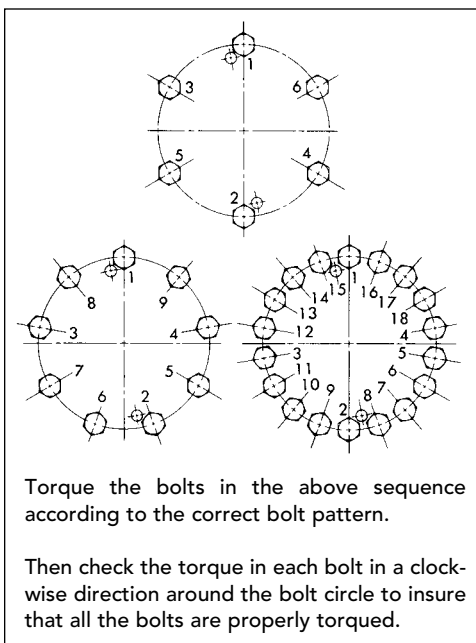

Figure 6-62

PMG Installation

1. Install inboard snap ring (430 frame generators) and loading spring on shaft (figure 6-65).
2. Slide PMG rotor onto shaft (figure 6-66).
3. Install snap ring (figure 6-67). Use a piece of pipe slightly larger than the shaft (2-3/4 inches) to push the rotor back against the loading spring until the snap ring seats in the slot (figure 6-68).
4. Install the PMG stator on it's mounting pads, with the leads in the left (9 o'clock) inboard position, and secure with the four mounting capscrews and belleville washers (figures 6-69 and 6-72). Torque to 6 ft-lb (8 N-m).
5. Route and secure PMG stator leads away from moving parts.

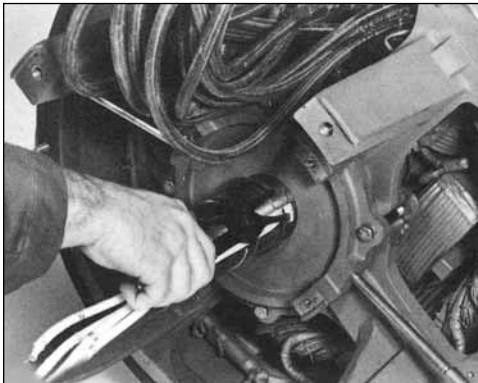

Figure 6-65



Figure 6-66

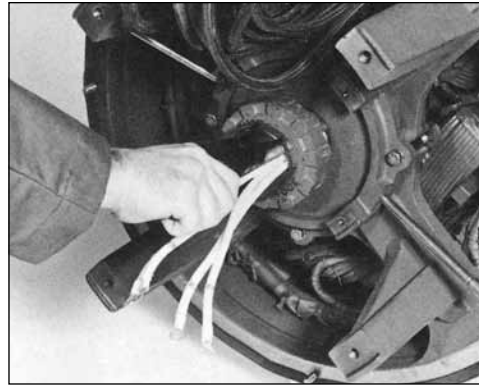

Figure 6-67

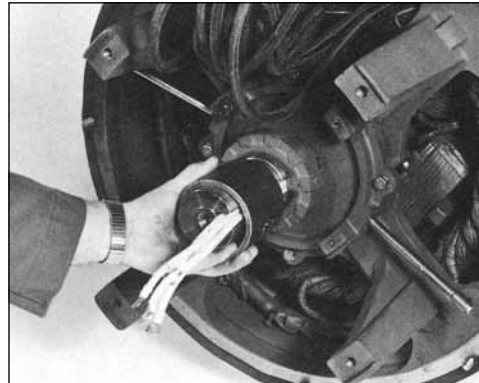

Figure 6-68



Figure 6-69

Exciter Installation

1. Attach a wire to the main rotor leads and feed the wire through the armature bore and out the lead hole in the aluminum standoff plate. On larger exciters, it will be helpful to install a guide pin in the end of the shaft to support the armature while fishing the rotor leads through (figure 6-70). Align the key in the armature bore to the keyway in the shaft. Slide the armature on the shaft while feeding the main rotor leads through the lead hole in the aluminum standoff plate (figure 6-71).

Insert the capscrew and belleville washer (figure 6-72) through the mounting hole in the aluminum standoff plate and secure to the shaft (figure 6-73). Tighten the capscrew until the armature seats on the shaft. Torque to 84 ft-lb (114 N-m) for 1/2" bolt or 300 ft-lb (407 N-m) for 3/4" bolt.

2. Observe the polarity markings and connect the main rotor leads to the rectifier assembly (figure 6-74). Torque the nuts to 4 ft-lb (5.4 N-m).
3. Position the exciter field leads at the left (9 o'clock) inboard position. Using a suitable lifting device, mount the exciter stator on the front end bracket mounting pads and align the mounting holes (figure 6-75). Mount with the capscrews and belleville washers (figure 6-72). Torque the capscrews to 60 ft-lb (81 N-m). Route and secure the exciter stator leads away from any moving parts.

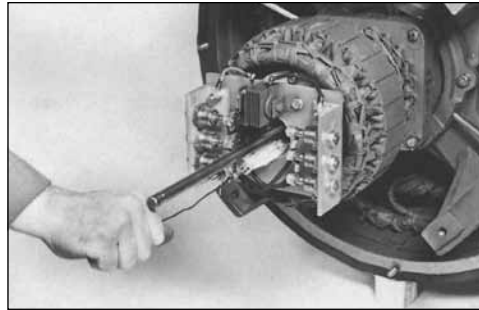

Figure 6-71

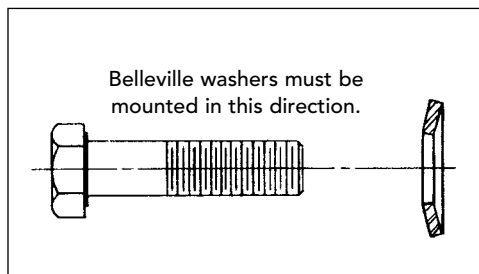

Figure 6-72

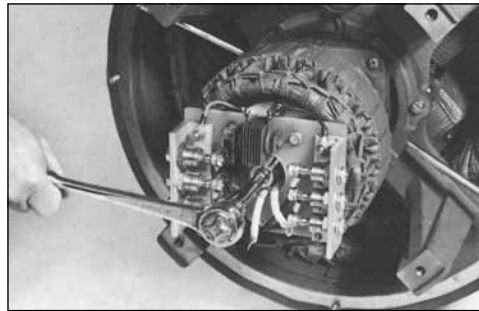

Figure 6-73

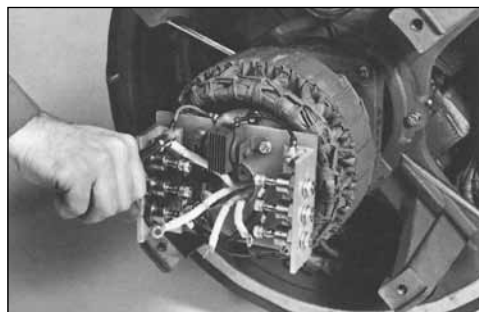

Figure 6-74

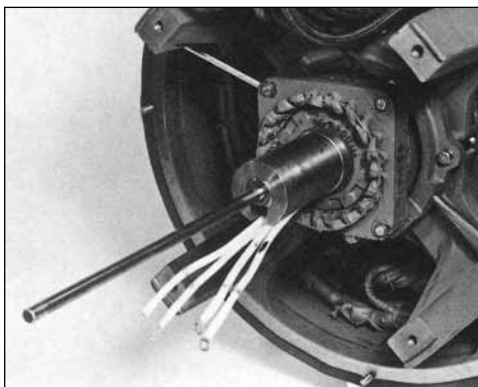

Figure 6-70



Figure 6-75

Conduit Box Installation

1. Install the conduit box over the main stator leads (be sure leads are in upper compartment). Secure with bolts and lock washers (figures 6-76 and 6-77).
2. On generators with bus bar assemblies, reassemble main stator leads and insulating blocks to bus bars (figure 6-78).
3. Reconnect exciter leads, PMG leads, and other accessories according to the connection diagrams and markings installed before disassembly.

Assembly to Prime Mover

1. Attach a suitable hoist to the generator lifting lugs and move the generator until the generator foot mounting holes are aligned with the base and slightly above.
2. a. For single bearing generators, if the screen assembly is mounted on the adapter, remove

the mounting bolts and remove the screen (figure 6-79). (**Note:** Do not remove the drip cover from the screen assembly if so equipped.) Insert two guide pins in the flywheel and two in the flywheel housing. Adjust the generator position until the drive discs are piloted in the flywheel. Remove the guide pins and secure the discs with Grade 8 place bolts and hardened washers or Grade 8 capscrews and heavy series lockwashers. Torque per specifications given in section 12.

⚠ WARNING Do not apply any force to the generator fan for lifting or rotating the generator rotor. Disregarding these instructions may cause personal injury or equipment damage.

Position the generator so that the SAE adapter mates with the flywheel housing.

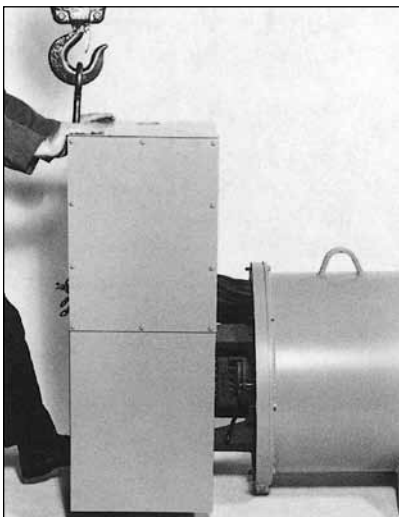

Figure 6-76



Figure 6-77

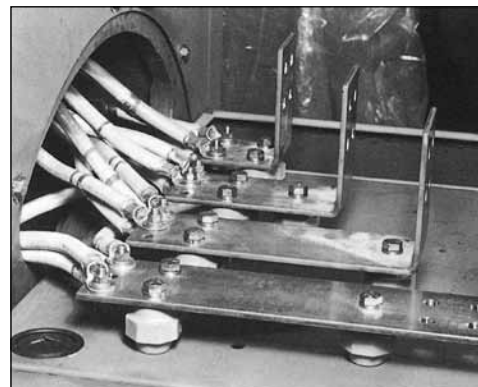

Figure 6-78

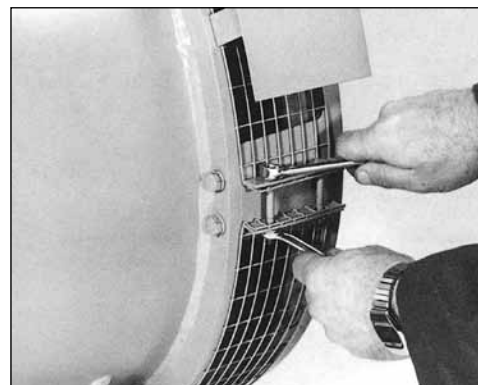

Figure 6-79

Service

CAUTION Do not force the alignment of the units. Shift the generator from side to side or raise or lower with a lifting device as necessary.

It may be necessary to use shims under the mounting feet of either the generator or the prime mover to obtain proper alignment; use the same shims as removed under disassembly or proceed as follows: using the extreme bottom four capscrews, mount the SAE adapter to the flywheel housing. With a .0015 to .002 inch feeler gauge placed at the extreme top of the adapter, between the adapter and flywheel housing, raise the generator or lower the prime mover until the gauge is snug. Relieve just enough to release the feeler gauge and torque the remaining SAE adapter cap-screws to the flywheel housing (torque specifications given in section 12).

Mount the screen assembly and tighten the mounting bolts.

- b. For two-bearing generators, align the coupling halves or sheaves between the generator and the prime mover by adding shims under the feet.
3. Shim under the generator feet for proper support, ensuring that the generator mounting surfaces are level.
4. Install the mounting bolts which secure the generator to the base.
5. For two bearing generators, assemble the coupling halves or sheave belts between the generator and the prime mover (follow the coupling manufacturer's instructions for assembly and alignment).
6. Connect all existing conduit or ducting to the conduit box.
7. Connect all external wiring to the generator inside the conduit box.
8. Check the exciter air gap (gap between the exciter armature and stator) by inserting a .010 inch feeler gauge in the gap and rotating it around the

armature diameter to ensure that a minimum air gap is available (see figure 6-80). If the feeler gauge cannot be rotated on full revolution, then check for a "cocked" exciter stator or loose stator mounting capscrews.

Note: On single bearing units, the exciter air gap cannot be checked properly until the generator is mounted to the prime mover.

9. Install the conduit box covers.

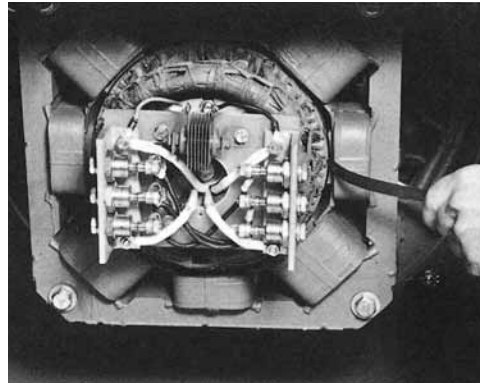

Figure 6-80

Introduction

This section is intended to suggest a systematic approach to locating and correcting generator or regulator malfunctions. The sections are arranged according to the symptoms of the problem. The steps in each section have been arranged in an attempt to:

- 1) Do the easy checks first.
- 2) Prevent further damage when troubleshooting a disabled machine.

The first and perhaps most important step of troubleshooting should be to gather as much information as possible from personnel who may have been present during the failure. Information on how long the generator had been running, what loads were on the line, weather conditions, what protective equipment operated, etc., can help isolate the problem.

Always make a thorough visual inspection to check for any obvious problems before attempting to run the generator.

⚠️ WARNING High voltages can be present at the generator and regulator terminals. High residual voltages can be present even with the regulator disconnected or its fuses removed. Some equipment (such as space heaters) may be energized when the generator is off. Tools, equipment, clothing, and your body must be kept clear of rotating parts and electrical connections.

⚠️ WARNING Special caution must be taken during troubleshooting since protective covers and safety devices may be disabled to gain access and make tests.

⚠️ WARNING Be careful. Serious personal injury or death can result from these hazards. Consult qualified personnel with any questions.

Troubleshooting

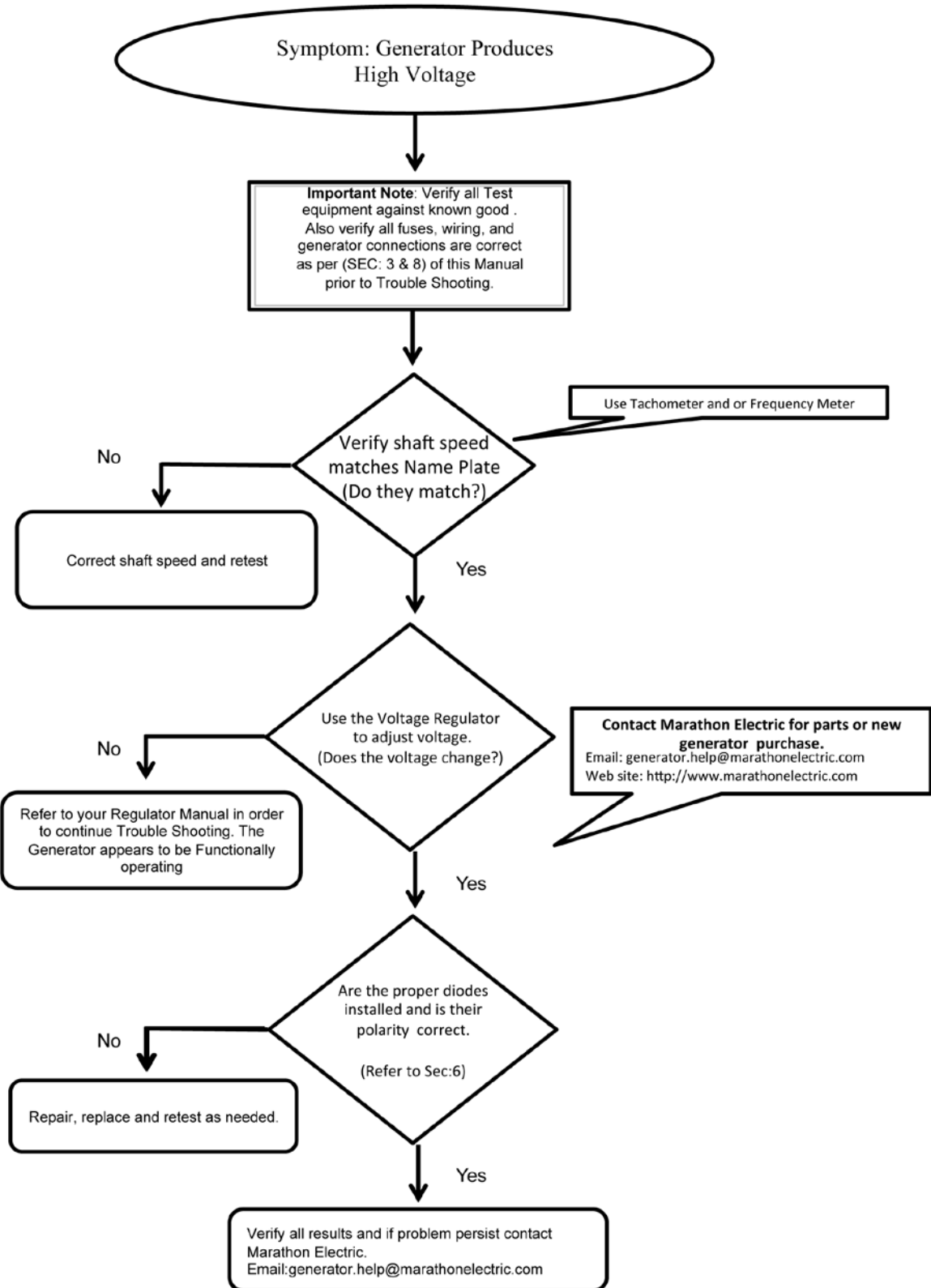

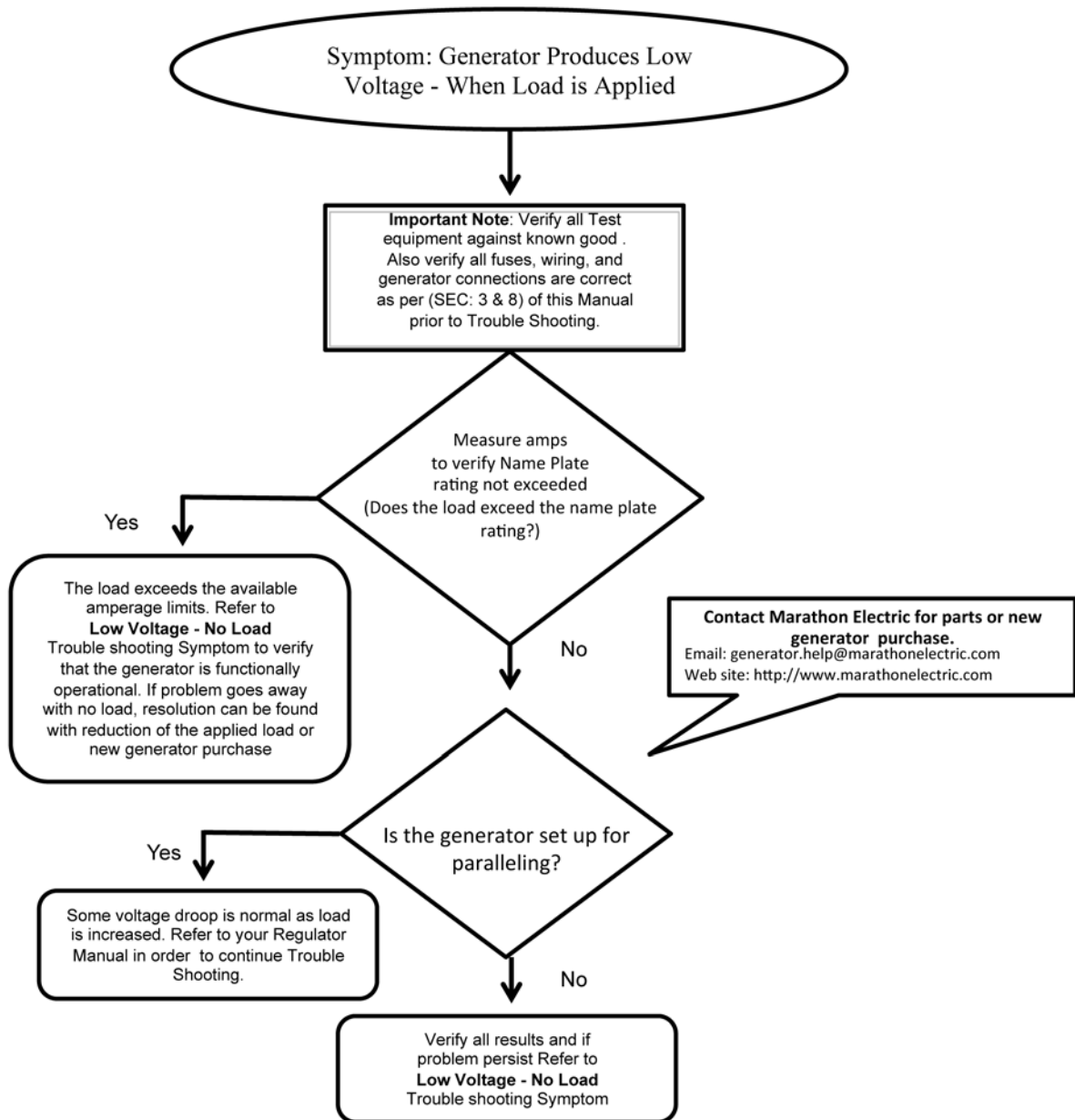

Troubleshooting

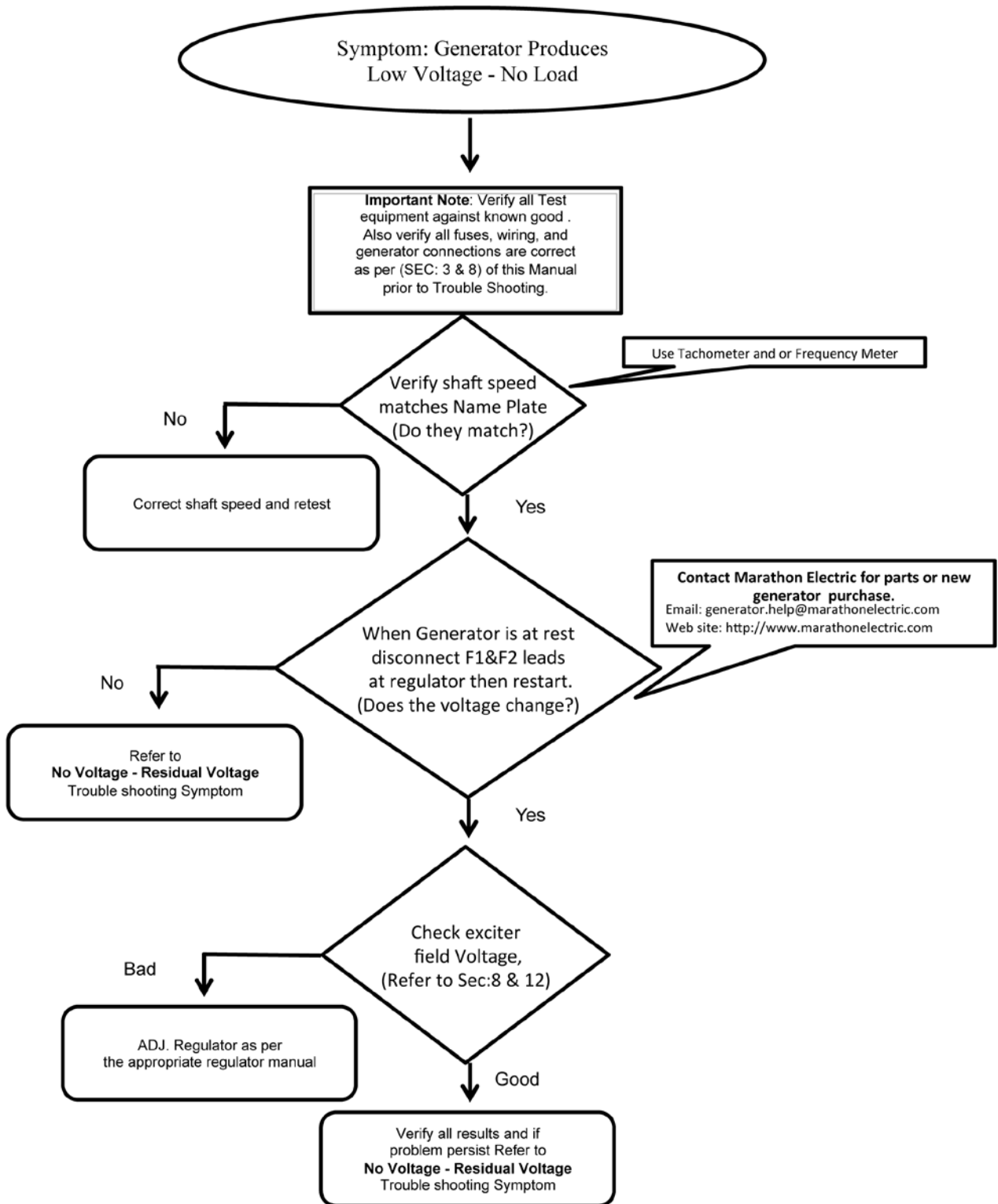

7

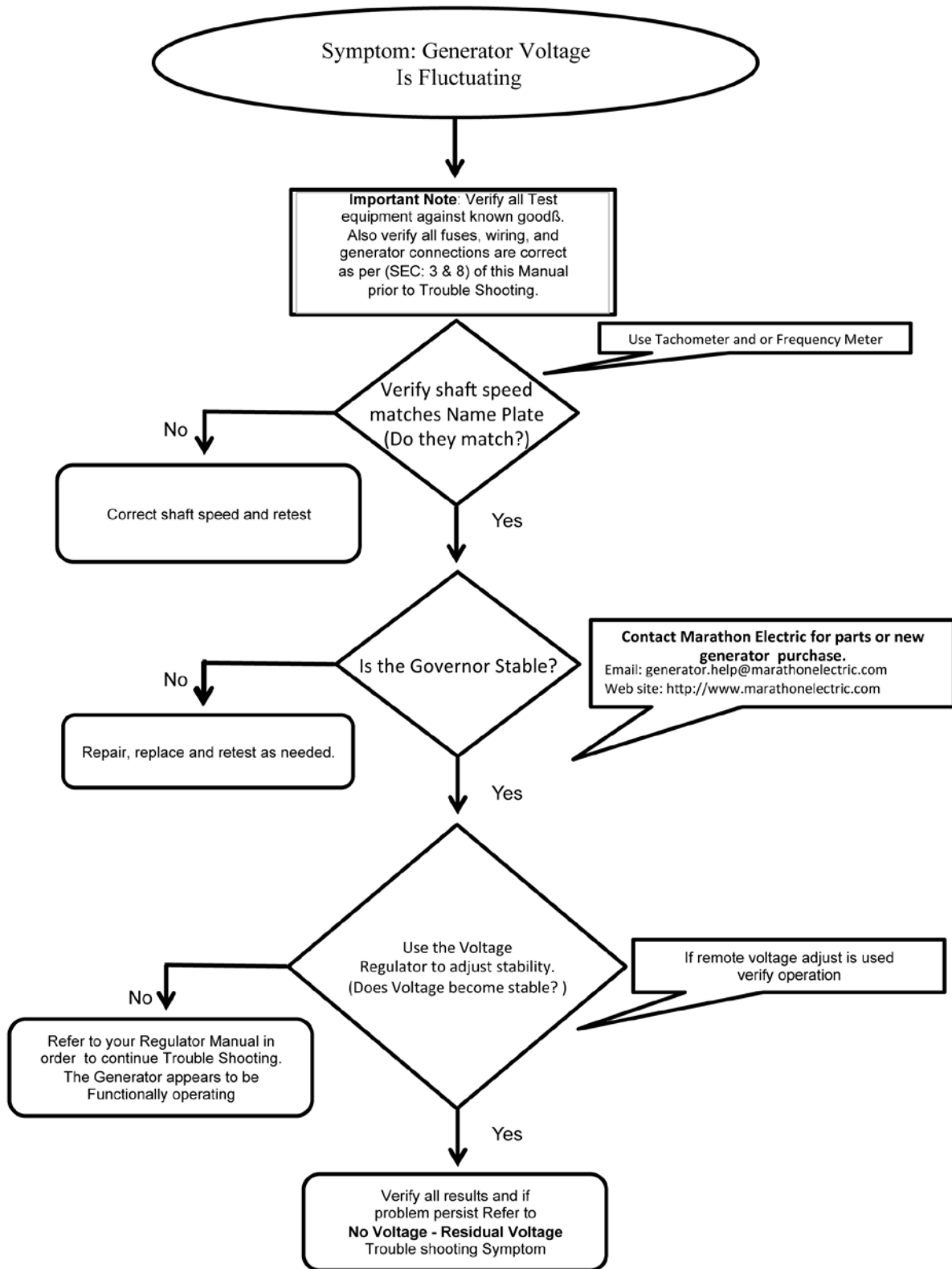

Troubleshooting

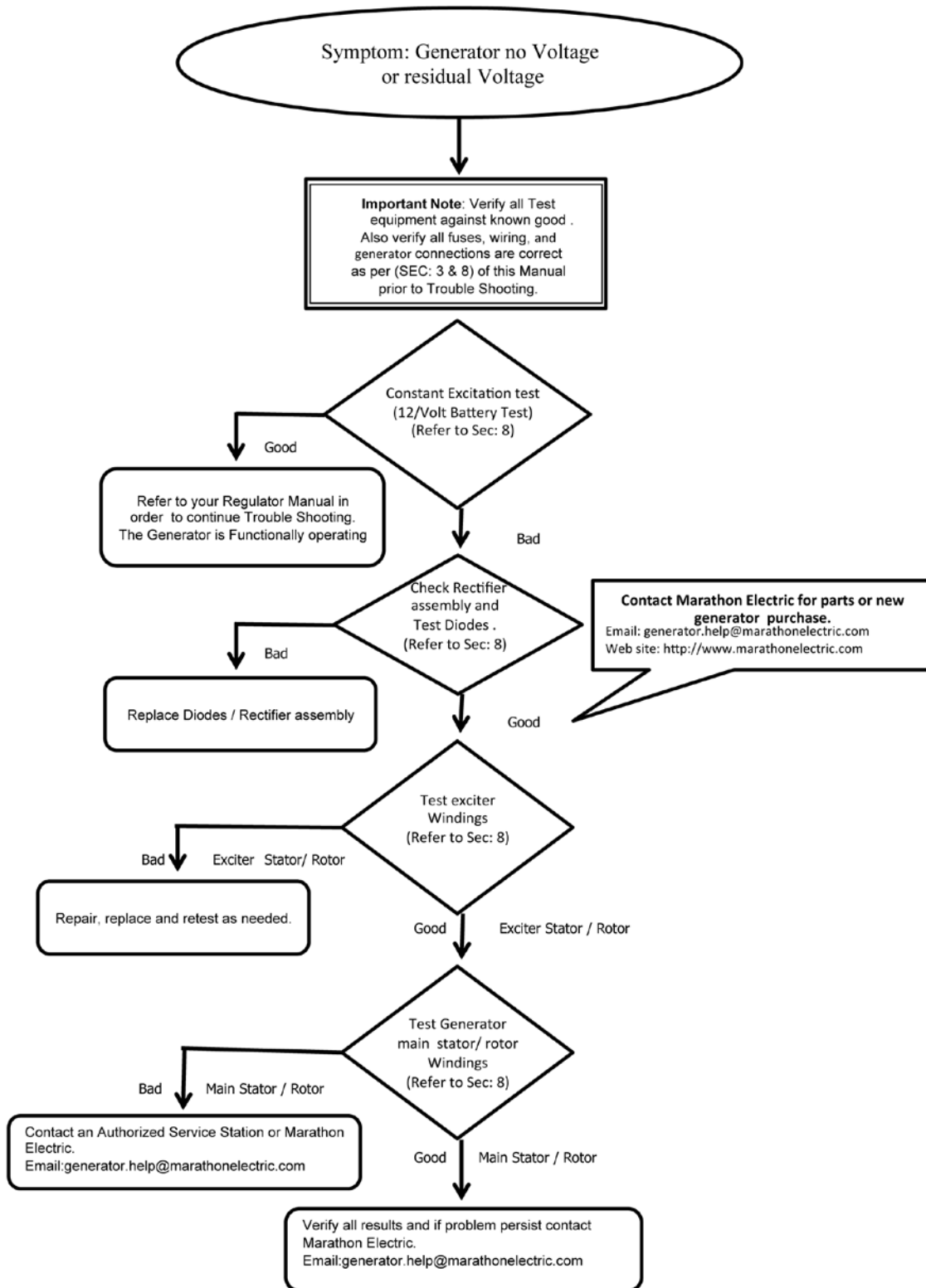

7

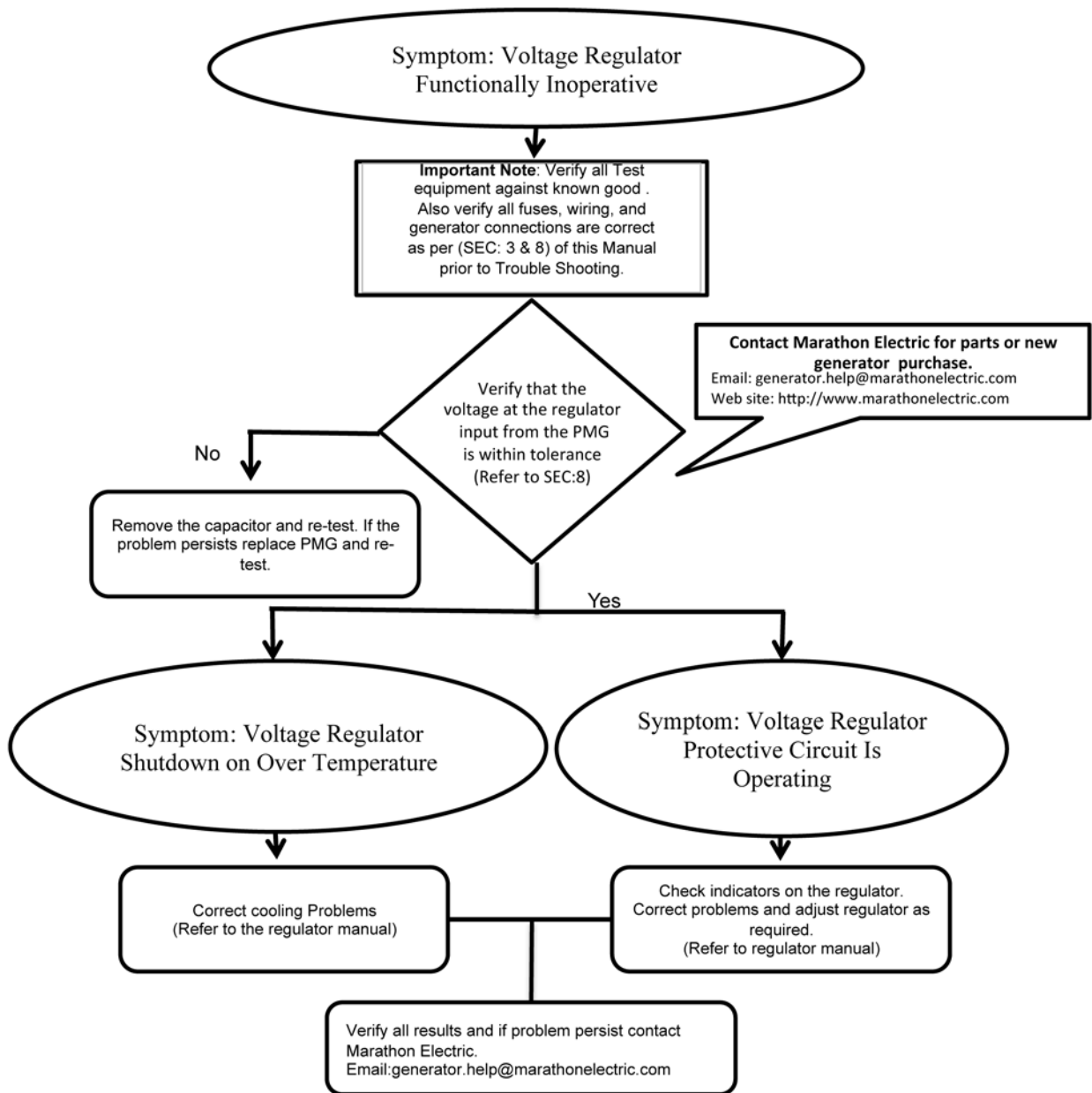

Troubleshooting

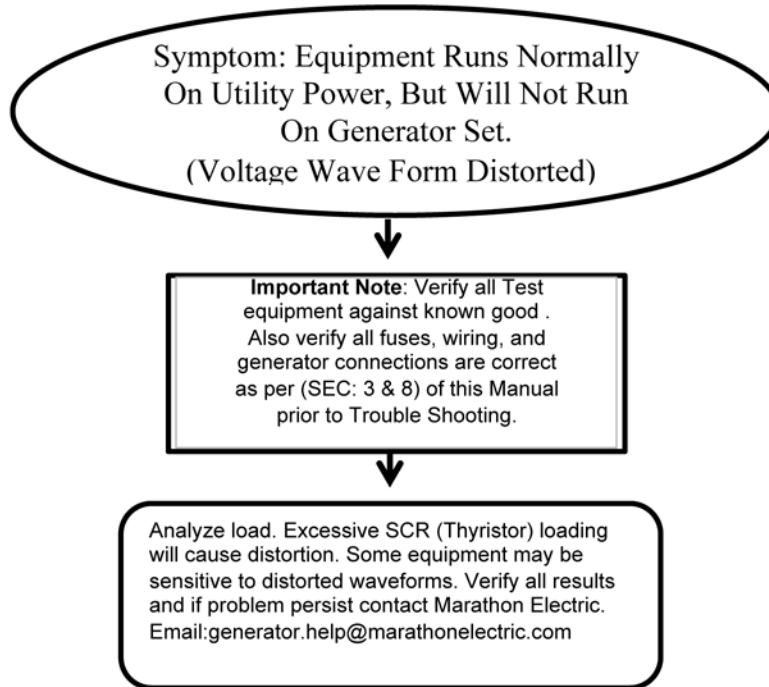

Visual Inspection

Whenever testing and troubleshooting a generator set, it is always a good practice to make a thorough visual inspection. Remove covers and look for any obvious problems. Burnt windings, broken connectors, leads, mounting brackets, etc., can usually be identified. Look for any loose or frayed insulation, loose or dirty connections, and broken wires. Be sure all wiring is clear of rotating parts.

Verify that the generator is connected for the voltage required. This is especially important on new installations.

Check for any foreign objects, loose nuts, bolts, and electrical connectors. Clear paper, leaves, building materials, etc., that could be sucked into the generator. (Generator is air cooled; air enters the lower portion of the conduit box.) Check the air gap for clearance or obstructions (main generator and exciter)

If possible, rotate the generator rotor by hand to be sure it turns freely.

If serious problems can be identified before attempting to operate the machine, additional damage can be avoided.

Constant Excitation (12V Battery) Test

Theory: The generator output voltage is dependent on generator speed, generator design, load, and exciter input current. If the generator speed and exciter input are known, the output voltage at no load can be measured and compared to the design value. Problems can be isolated to either the generator or regulator system by using this test.

Test Procedure:

1. Shut the generator set down.
2. Connect a voltmeter to the generator output.
3. Disconnect the F1 and F2 leads at the regulator.
4. Connect a 12 volt battery capable of supplying 1 amp to the F1 and F2 leads. F1 is plus (+), F2 is minus (-).

CAUTION Beware of arcing when connecting leads. Stay clear of battery vents. Escaping hydrogen gas can explode. If hazardous conditions exist, use a suitable switch to connect or disconnect the battery.

5. With no load applied to on the generator (main breakers open), run generator at rated speed (1800 rpm – 60 Hz or 1500 rpm – 50 Hz).
6. Measure the generator output voltage.
7. Shut generator down.
8. Disconnect battery (see preceding CAUTION statement).
9. Compare voltage reading with value shown in section 12.

Conclusion: If voltage readings are normal, the main generator and exciter are operating properly. Troubleshooting should continue with the regulator. If readings are not normal, the problem is in the generator. Continue testing diodes, surge suppressor, and windings.

Measuring Voltages

When testing the generator and regulator, the most frequent (and usually easiest) measurement will be a voltage. The generator will need to be running at rated speed and may have some of the protective guards and covers removed. **Be Careful.** Keep yourself and your test leads out of the way. It is best to shut the unit down when connecting meters. When using alligator clips or push-on terminals, be sure the leads are supported so vibration does not shake them loose when running the generator set.

See figure 8-1 for measurement points and expected meter range settings. When in doubt, start with a higher range and work down.

Consult meter instruction manual to verify its operation and limitations.

Generator Testing

Figure 8-1: Typical Voltage Measurements

Voltage Measurement	Test Point	Meter/Range Selection Requirement	
Generator Output Voltage	Output "T" leads or bus bars, also main circuit breaker "line" side.	System voltage – volts AC (see generator nameplate and connection diagram).	
Regulator Output (Exciter Stator Input)	F1 and F2 terminals at the regulator.	200 volts DC range. F1 is plus (+) and F2 is minus (-).	
Regulator Sensing Voltage	E1, E2, and E3 terminals at the regulator.	Usually the same as the system voltage (generator output volts); however, in some cases, sensing is taken from winding center taps or instrument potential transformers. Maximum 600 volts AC. Example: Center tap of 480 volt system would give 240 volts at E1, E2, or E3. Example: A 4160 volt system must use a transformer to step voltage down below 600 volts. See the connection diagram supplied with generator set.	
Regulator Input Volts (PMG Output Volts)	"PMG" leads at the regulator or capacitor.	200-240 VAC 180-220 VAC	300 Hz @ 1800 rpm 250 Hz @ 1500 rpm

Current (Amp) Measurements

Current measurements (AC) can be easily taken with a clamp-on type meter.

Note: Most clamp-on ammeters will not measure DC.

When measuring generator output current, be sure the clamp is around all cables **for each phase**. If the physical size of the conductors or the capacity of the meters will not permit all cables to be measured at once, each one can be measured individually. Add the individual readings together to get the total. Compare readings to the generator nameplate (nameplate ratings are always given per phase).

Amperage should never exceed the nameplate rating when running the intended load (amperage may go above nameplate momentarily when starting large motors).

When measuring exciter field amps (F1 and F2 leads), a DC meter is required. The maximum field current under full regulator forcing is 6.5 amps DC. Normal full load reading is approximately 3 amps DC.

Measuring Resistance

The generator windings can be measured and compared to the values shown in the service specification section 12.

Main Stator

The main stator winding resistance is very low. A meter capable of readings in the milliohm range would be required; however, a standard VOM (volt ohm meter) can be used to check for continuity, shorts, or grounds.

Example: With leads disconnected, a measurement from T1 to T4 should be very low (continuity on most VOMs). Measured from T1 or T4 to any other lead should be infinite. Measure from the "T" lead to the generator frame to check for grounds (reading should be infinite).

Exciter Stator

The exciter stator resistance is measured by disconnecting the F1 and F2 leads at the regulator. Measure the resistance between the leads (this value is 22–24 ohms on standard generators). Measure from the leads to the frame to check for grounds.

Main Rotor

Note markings and disconnect the main rotor leads (F1 leads and F2 leads) from the rectifier assembly. Measure the resistance of the main rotor winding. Compare reading to value shown in service specification, section 12. Measure from the leads to the exciter mounting bolt to check for grounds.

Exciter Rotor

Disconnect the exciter rotor leads at the diodes (leave leads disconnected if proceeding to check diodes). Measure resistance between phases. Compare value to service specifications, section 12. Measure from the leads to the exciter mounting bolt to check for grounds.

Testing Diodes (Rectifiers)

Diodes perform the function of an “electrical check valve.” They conduct in one direction only and are used to “rectify” AC current into DC current. To test, measure the resistance first in one direction and then reverse the leads and test in the other direction. The reading should be high in the reverse direction and low in the forward direction. A shorted diode will read low in both directions. An open diode will read high in both directions.

Notes:

1. Two different polarities of diodes are used. The only difference is in the way the device is mechanically placed in the case. When changing diodes, be sure the correct polarity is used (refer to section 6, figure 6-34).
2. Some meters do not have enough voltage output from their internal batteries to turn the diode on (about 0.6 volts is required), and the voltage can change with different range settings. Consult the instruction manual for your meter.
3. Polarities supplied by the meter’s internal battery may or may not correspond to the (+) (-) markings on the meter.

Insulation Resistance – General

Insulation resistance is a measurement of the integrity of the insulating materials that separate the electrical windings from the generator’s steel core. This resist-

ance can degrade over time or due to contaminants (dust, dirt, oil, grease, and especially moisture). Most winding failures are due to a breakdown in the insulation system. In many cases, low insulation resistance is caused by moisture collected when the generator is shut down. The problem can be corrected simply by drying out the windings (see section 5).

Normally the resistance of the insulation system is on the order of millions of ohms. It is measured with a device called a “megger” which is a megaohm meter (meg is for million) and a power supply. The power supply voltage varies, but the most common is 500 Vdc. A megger voltage over 500 is not recommended, except for measuring medium voltage (2400/4160) stators only.

CAUTION First disconnect any electronic components. Regulators, diodes, surge protectors, protective relays, etc., will be destroyed if subjected to the high megger voltages.

To measure insulation resistance, connect the red or positive megger lead to the leads for the winding to be tested, connect the back or negative megger lead to the generator frame. Be sure the leads of the part being tested are not touching any metal parts of the generator (if the neutral is grounded, it must be disconnected). Take megger reading (refer to the manual for the megger).

Insulation Resistance – Main Stator

CAUTION Be sure the regulator, and any other electric components, metering, protective relays, etc., are disconnected before meggering. High megger voltages will destroy these parts.

All stator leads must be isolated from ground and connected together (on most systems with grounded neutrals, the neutral can be isolated from ground and used as a test point). Connect the positive megger lead to the main stator leads. Connect the negative megger lead to the generator grounding stud. Take the megohm reading (refer to instructions for the megger).

Generator Testing

The minimum acceptable value for random wound coils is 5 megohms. For form wound coils, the value is 100 megohms.

If the reading is below the recommended value, the winding must be dried out or repaired.

Insulation Resistance – Main Rotor

Disconnect the main rotor leads from the diode bridge on the exciter rotor. Connect the leads together with the positive megger lead. Connect the negative megger lead to a good ground on the rotor assembly such as the exciter mounting bolt. Take the megohm reading (refer to instructions for the megger).

The minimum value is 5 megohms.

If the reading is low, the winding must be dried out or repaired.

Insulation Resistance – Exciter Stator

Disconnect the exciter leads F1 and F2 from the regulator. Never subject the regulator to a megger. Connect F1 and F2 together with the positive megger lead. Connect the negative megger lead to the ground stud. Take the megohm reading (refer to instructions for the megger).

The minimum value is 5 megohms.

If the reading is low, the winding must be dried out or repaired.

Insulation Resistance – Exciter Rotor

Disconnect the exciter rotor windings (6 leads from the diodes). Connect all leads together with the positive megger lead. Connect the negative megger lead to a good ground on the rotor assembly such as the mounting bolt. Take the megohm reading (refer to the instructions for the megger).

The minimum value is 5 megohms.

If the reading is low, the winding must be dried out or repaired.

Main Rotor Field AC Impedance Test

Theory: The main rotor resistance can be measured with a very accurate meter that is able to measure low (1 ohm) resistance, but it is difficult to determine if there are turn-to-turn shorts in the field pole windings. One shorted turn would only change a resistance reading on the order of one half of one percent.

The AC impedance test measures the impedance (inductance and resistance) of the field pole coils. Shorted turns in the field pole windings change the coil inductance to a much greater degree than the resistance.

Procedure:

Step 1: The rotor must be supported on a non-magnetic surface such as a wooden skid. Do not use a steel table that would create a magnetic "short circuit" between the poles.

Step 2: Apply 120 volts AC to disconnected main rotor leads F1 and F2.

Step 3: Measure and record voltages across each pole. Between points "A" and "B", "B" and "C", "C" and "D", and "D" and "E" (figure 8-1).

Step 4: The voltage readings should balance within one volt.

Results: If the AC voltages are not balanced ($30V \pm 1V$ AC with 120V AC input) across each pole, the winding has shorted turns and should be rewound.

Refer to Marathon Electric for further information.

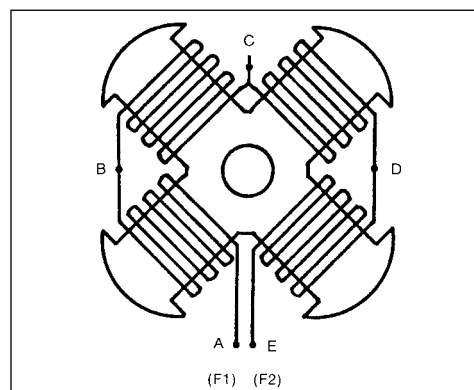
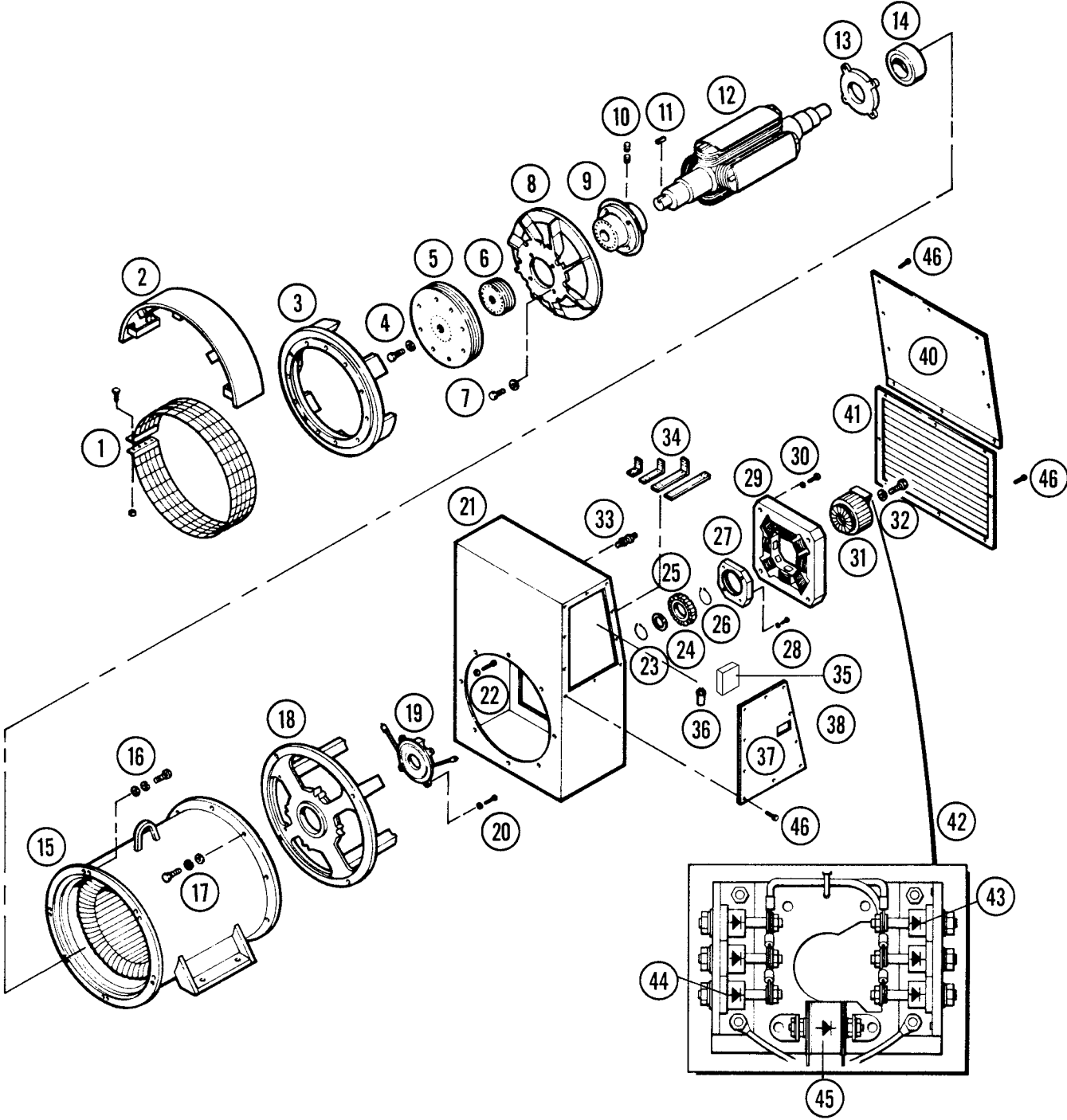

Figure 8-1

MAGNAMAX^{DVR} Exploded View



Parts

Table 9-1: Parts List

Item	Part Description	Item	Part Description	Item	Part Description
1	Screen Assembly Screen Screen Mounting Bolt Screen Mounting Nut	11	Drive Hub Key	32	Exciter Rotor Fastener Capscrew Belleville Washer
2	Drip Cover Assy (Option)	12	Main Rotor Assembly With Windings	33	Grounding Stud Assembly Stud Washer Nut
3	SAE Adapter #3 Adapter #2 Adapter #1 Adapter #1/2 Adapter #0 Adapter #00 Adapter (#18 Disc) #00 Adapter (#21 Disc)	13	Front Bearing Cap	34	Bus Bar Assembly
4	Disc Mounting Fasteners Capscrew for #11-1/2 Capscrew for #14 Capscrew for #18 Capscrew for #21 Capscrew for Delco Hardened Washer	14	Front Ball Bearing	35	Voltage Regulator
5	Drive Discs #11-1/2 Disc #14 Disc #18 Disc #21 Disc Delco Disc (17.75" OD)	15	Main Body Assembly	36	Capacitor
6	Spacers For #11-1/2 Disc For #14 Disc For #18 Disc For #21 Disc For Delco Disc	16	Adapter Mtg Fasteners Capscrew Lock Washer Flat Washer	37	Side Panels Blank Machined For Regulator
7	Fan Mounting Fasteners Capscrew Capscrew (2 brg. only) Belleville Washer	17	Bracket Mtg Fasteners Capscrew Lock Washer Flat Washer	38	Fuse
8	Fan	18	Front Bracket	40	Solid Cover
9	Hub Drive Hub (single brg. only) Fan Hub (2 brg. only)	19	PMG Bearing Cap	41	Louvered Cover
10	Drive Hub Set Screws	20	Bearing Cap Fasteners Capscrew Lock Washer	42	Exciter Rect. Assembly (incl. 43, 44, 45)
		21	Conduit Box	43	Diode Standard Polarity
		22	Conduit Box Mounting Fasteners Capscrew Lock Washer	44	Diode Reverse Polarity
		23	Snap Ring – Inner	45	Surge Suppressor
		24	Loading Spring	46	Cover Mounting Screws
		25	PMG Rotor		
		26	Snap Ring – Outer		
		27	PMG Stator		
		28	PMG Stator Mtg Fasteners Capscrew Belleville Washer		
		29	Exciter Stator		
		30	Exciter Stator Fasteners Capscrew Belleville Washer		
		31	Exciter Rotor Assembly (incl. 42) 430 Frame – All 570 Frame – Low Voltage 570 Frame – Medium Voltage		

Note: This parts list is for reference only. Always give complete generator model and serial numbers when ordering parts.

Standard Tools

The MAGNAMAX^{DVR} generator is assembled with American standard SAE hardware. Wrench sizes from 5/16 inch to 7/8 inch are used. A socket head set screw is used in the drive hub. A 1/4 inch allen type wrench is required to remove it.

All fasteners should be properly torqued (see section 12). Torque wrenches ranging from 25 in-lb through 200 ft-lb should be available.

Electrical test equipment should include a voltmeter or multimeter (VOM), clamp on ammeter, accurate frequency meter or tachometer and a megohmmeter. (See section 8 – Generator Testing for more information.)

Special Tools

In addition to the standard tools mentioned above, the following special tools will facilitate removal and installation of large and/or special parts. These tools can be obtained from the Marathon Electric parts department.

Exciter Stator Lifting Fixture (figure 10-1) – In cases where the exciter stator is to be serviced without removing the generator conduit box, this fixture can be used with overhead rigging to remove and reinstall the exciter stator.

Exciter Rotor Puller Bolt (figure 10-2) – The exciter rotor has a built-in pulling system. With the use of this bolt, the rotor can be easily removed from the shaft without damage to the winding.

Snap Ring Pliers (figure 10-3) – The PMG rotor is installed to the generator shaft with a snap ring. The nominal shaft diameter is 2-3/4 inches and the ring must be spread approximately 3/4 inches for removal. To install the snap ring, use a piece of pipe with a 2-3/4 inch ID (figure 10-4). Push the PMG rotor and snap ring onto the shaft until the ring snaps into the groove.

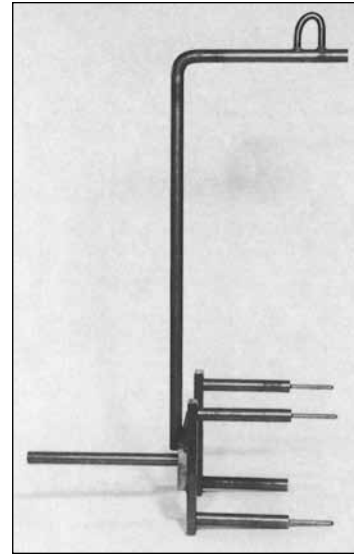

Figure 10-1

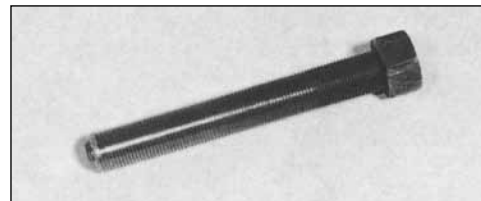

Figure 10-2



Figure 10-3

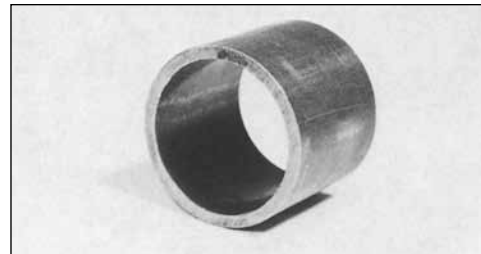

Figure 10-4

Special Tools

Rotor Lifting Fixture (figure 10-5) – The main generator rotor is heavy (approx. 1/2 the weight of the generator) and difficult to handle. The proper fixture should be used whenever removing or installing the main rotor into the main stator. Without proper care and equipment, the windings can be easily damaged.

Miscellaneous

A selection of wiring devices such as electric connectors, tape, cable ties, crimping and stripping tools, etc., should also be a part of the generator service tool kit. The standard regulator uses flat 1/4 inch female insulated terminals for AWG #14 wire.

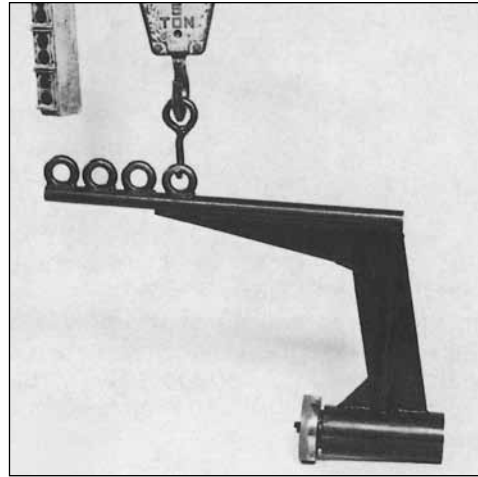

Figure 10-5

Preparation For Shipment Or Extended Storage

Shipping Instructions

Shipping and handling will be much easier if the generator is fastened to a suitable shipping skid that will allow handling by a forklift. The skid should extend beyond the generator in all directions. If the original skid is available, it should be used. Marathon Electric will supply shipping skid drawings upon request.

Overseas shipping may require special export crating. Check with your freight carrier.

When installed, single bearing generator rotors are supported on the drive end by the drive discs bolted to the engine flywheel. When the engine is removed, the rotor must be supported by an appropriate fixture to prevent main rotor, main stator, or exciter damage (figure 11-1). Before shipping any single bearing generator, the main rotor must be supported by the adapter using an appropriate fixture.

CAUTION Do not attempt to transport any generator without proper rotor support. Extensive equipment damage can occur.

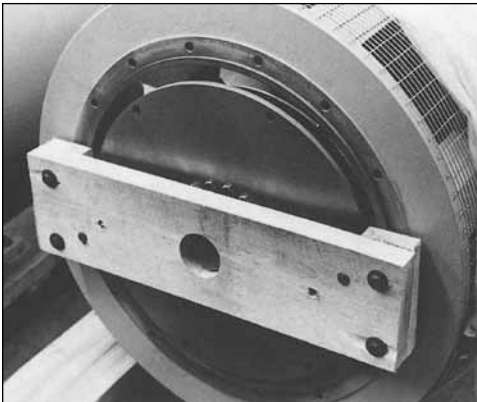

Figure 11-1

Storage Instructions

If the generator or gen-set is placed into storage, the following precautions should be taken to protect it:

- A. Equipment must be kept clean.
 - 1. Store indoors.
 - 2. Keep covered to eliminate airborne dust and dirt.
 - 3. Cover openings for ventilation, conduit connections, etc., to prevent entry of rodents, snakes, birds, insects, etc.
- B. Equipment must be kept dry.
 - 1. Store in a dry area indoors.
 - 2. Temperature swings should be minimal to prevent condensation.
 - 3. If stored in an unheated or damp building, space heaters will be required to prevent internal condensation.
 - 4. Treat unpainted flanges, shafts, drive discs, and fittings with a rust inhibitor.
 - 5. Check insulation resistance of all windings **before** starting the generator. If readings are low, the windings must be dried (see section
- C. Keep bearings lubricated.
 - 1. Every six months, rotate shaft several turns to distribute grease in bearings.
 - 2. If unit has been stored more than one year, add grease before start-up.
- D. Review and follow instructions in sections 3 and 4 before putting the gen-set into service.

Specifications



Table 12-1: MAGNAMAX^{DVR}® – Fastener & Torque Specifications

Part Description	Fastener Spec. ③	430-570 Frames		740 Frames	
		Size ① Dia.–Thread	Torque ② Ft-Lb	Size ① Dia.–Thread	Torque ② Ft-Lb
Front Bracket	Grade 5 capscrews with flat and lock washers	3/8-16	25	1/2-13	60
Bearing Caps	Grade 5 capscrews with lock washers	3/8-16	25	3/8-16	25
Drive Disc	Grade 8 capscrews with hardened washers	5/8-18	192	5/8-18	192
Adapter (or Rear Bracket)	Grade 5 capscrews with flat and lock washers	3/8-16	25	1/2-13	60
Conduit Box	Grade 5 capscrew with star type lock washer	3/8-16	25	1/2-13	60
PMG Stator	Grade 5 capscrews with belleville washers	1/4-20	6	1/4-20	6
Exciter Stator	Grade 5 capscrews with belleville washers	1/2-13	60	1/2-13	60
Exciter Armature (Rotor)	Grade 8 capscrew with belleville washer	1/2-13 3/4-10	84 300	1/2-13 3/4-10	84 300
Cooling Fan	Grade 5 capscrews with belleville washers	1/2-13	60	1/2-13	60
Main Rotor Coil Supports ④	Grade 8 capscrews with belleville washers	5/16-18	19	3/8-16	35
Rectifier Assembly Mounting	Grade 5 capscrews	1/4-20	4	1/4-20	4
Drive Hub Set Screw	Socket head set screw – 1/4 in. hex key	1/2-13	50	1/2-13	50

NOTES:

- ① All fasteners are SAE (American) standard.
- ② All torque values are for plated hardware which is standard on the MAGNAMAX^{DVR}®. If hardware is replaced with non-plated, refer to Table 12-2.
- ③ Always use quality hardware of the grade specified.
- ④ 570 and 740 frame only. Not used on 430 frames.

Table 12-2: Capscrew Torque Values

Capscrew Dia. and Ultimate Tensile Strength (PSI)	To 1/2 – 69,000 PSI To 3/4 – 64,000 PSI To 1 – 55,000 PSI			To 3/4 – 120,000 PSI To 1 – 115,000 PSI			150,000 PSI		
SAE Grade Number	1 or 2			5			8		
Capscrew Head Markings									
Capscrew Body Size (Inches) – (Thread)	Torque Ft-Lb (N-m)			Torque Ft-Lb (N-m)			Torque Ft-Lb (N-m)		
	Dry	Oiled	Plated	Dry	Oiled	Plated	Dry	Oiled	Plated
1/4 - 20	5 (7)	4.5 (6)	4 (5)	8 (11)	7 (9)	6 (8)	12 (16)	11 (15)	10 (14)
- 28	6 (8)	5.4 (7)	4.8 (6)	10 (14)	9 (12)	8 (11)	14 (19)	13 (18)	11 (15)
5/16 - 18	11 (15)	10 (14)	9 (12)	17 (23)	15 (20)	14 (19)	24 (33)	22 (30)	19 (26)
- 24	13 (18)	12 (16)	10 (14)	19 (26)	17 (23)	15 (20)	27 (37)	24 (33)	22 (30)
3/8 - 16	18 (24)	16 (22)	14 (19)	31 (42)	28 (38)	25 (34)	44 (60)	40 (54)	35 (47)
- 24	20 (27)	18 (24)	16 (22)	35 (47)	32 (43)	28 (38)	49 (66)	44 (60)	39 (53)
7/16 - 14	28 (38)	25 (34)	22 (30)	49 (66)	44 (60)	39 (53)	70 (95)	63 (85)	56 (76)
- 20	30 (41)	27 (37)	24 (33)	55 (75)	50 (68)	44 (60)	78 (106)	70 (95)	62 (84)
1/2 - 13	39 (53)	35 (47)	31 (42)	75 (102)	68 (92)	60 (81)	105 (142)	95 (129)	84 (114)
- 20	41 (56)	37 (50)	33 (45)	85 (115)	77 (104)	68 (92)	120 (163)	108 (146)	96 (130)
9/16 - 12	51 (69)	46 (62)	41 (56)	110 (149)	99 (134)	88 (119)	155 (210)	140 (190)	124 (168)
- 18	55 (75)	50 (68)	44 (60)	120 (163)	108 (146)	96 (130)	170 (230)	153 (207)	136 (184)
5/8 - 11	83 (113)	75 (102)	66 (89)	150 (203)	135 (183)	120 (163)	210 (285)	189 (256)	168 (228)
- 18	95 (129)	86 (117)	76 (103)	170 (230)	153 (207)	136 (184)	240 (325)	216 (293)	192 (260)
3/4 - 10	105 (142)	95 (130)	84 (114)	270 (366)	243 (329)	216 (293)	375 (508)	338 (458)	300 (407)
- 16	115 (156)	104 (141)	92 (125)	295 (400)	266 (361)	236 (320)	420 (569)	378 (513)	336 (456)
7/8 - 9	160 (217)	144 (195)	128 (174)	395 (535)	356 (483)	316 (428)	605 (820)	545 (739)	484 (656)
- 14	175 (237)	158 (214)	140 (190)	435 (590)	392 (531)	348 (472)	675 (915)	608 (824)	540 (732)
1 - 8	235 (319)	212 (287)	188 (255)	590 (800)	531 (720)	472 (640)	910 (1234)	819 (1110)	728 (987)
- 14	250 (339)	225 (305)	200 (271)	660 (895)	594 (805)	528 (716)	990 (1342)	891 (1208)	792(1074)

NOTES:

① Capscrews threaded into aluminum may require reductions in torque of 30% or more.

Specifications

Table 12-3: Excitation Data – 60 Hz – 1800 RPM

Model Number Low Volts	Exciter Field Resistance Ohms @ 25°C	Exciter Field Volts F1 & F2 at Regulator		No Load Output Voltage W/Fixed Excitation High Wye Connection [Ⓜ]	
		No Load [Ⓛ]	240/480 Volts	12V DC	24V DC
431RSL4005	22.5	13.3		460	550
431RSL4007	22.5	14.2		450	545
432RSL4009	22.5	15.3		445	535
432RSL4011	22.5	13.5		460	550
432RSL4013	22.5	11.3		490	580
432RSL4015	22.5	13.1		440	530
432RSL4017	22.5	14.4		450	545
433RSL4019	22.5	16.9		430	525
433RSL4021	22.5	13.7		450	550
572RSL4024	23.0	16.1		440	520
572RSL4027	23.0	16.1		440	520
572RSL4028	23.0	17.5		425	510
572RSL4030	23.0	15.2		440	530
573RSL4032	23.0	15.0		445	530
573RSL4034	23.0	17.0		430	520
574RSL4036	23.0	18.2		420	510
574RSL4038	23.0	15.0		440	540
575RSL4044	23.0	18.8		410	510
740RSL4046	23.0	18.9		410	510
741RSL4045	22.0	15.2		440	540
742RSL4046	22.0	15.6		430	540
742RSL4048	22.0	17.4		410	525
742RSL4050	22.0	13.7		460	565
743RSL4052	22.0	19.4		400	510
744RSL4054	22.1	18.6		400	510
744RSL4056	22.1	19.4		400	515
744RSL4058	22.1	20.3		400	515
744FSL4060	22.1	15.1		420	570
744FSL4062	22.1	16.6		410	535

Model Number Medium Volts	Exciter Field Resistance Ohms @ 25°C	Exciter Field Volts F1 & F2 at Regulator		No Load Output Voltage W/Fixed Excitation Wye Connection [Ⓜ]	
		No Load [Ⓛ]	4160 Volts	12V DC	24V DC
573FSM4352	23.0	23.5		3100	4200
573FSM4354	23.0	20.3		3300	4400
574FSM4356	23.0	20.7		3200	4300
574FSM4358	23.0	17.3		3500	4600
741FSM4360	22.0	16.7		3600	4600
742FSM4364	22.0	15.4		3700	4700
742FSM4366	22.0	16.3		3600	4600
743FSM4368	22.1	17.7		3200	4600
743FSM4370	22.1	17.0		3500	4600
744FSM4374	22.1	17.5		3600	4650
744FSM4376	22.1	17.5		3600	4650

NOTES: [Ⓛ] For rated load exciter field volts – see generator nameplate; [Ⓜ] For low wye connection: divide value shown in table by 2; For high delta connection: divide value shown in table by 1.732; [Ⓝ] For delta connection: divide value shown in table by 1.732.

Table 12-4: Excitation Data – 50 Hz – 1500 RPM

Model Number Low Volts	Exciter Field Resistance Ohms @ 25°C	Exciter Field Volts F1 & F2 at Regulator No Load ^① 415 Volts	No Load Output Voltage W/Fixed Excitation High Wye Connection ^②	
			12V DC	24V DC
431RSL4005	22.5	15.6	380	460
431RSL4007	22.5	17.1	370	450
432RSL4009	22.5	18.0	360	445
432RSL4011	22.5	16.0	380	455
432RSL4013	22.5	13.1	400	480
432RSL4015	22.5	18.7	360	440
432RSL4017	22.5	17.4	370	450
433RSL4019	22.5	20.7	340	430
433RSL4021	22.5	16.7	360	450
572RSL4024	23.0	19.8	360	430
572RSL4027	23.0	20.0	355	430
572RSL4028	23.0	21.2	370	430
572RSL4030	23.0	18.4	360	440
573RSL4032	23.0	18.9	360	440
573RSL4034	23.0	20.7	350	430
574RSL4036	23.0	21.6	345	425
574RSL4038	23.0	17.7	365	450
575RSL4044	23.0	21.8	340	420
740RSL4046	23.0	21.9	340	420
741RSL4045	22.0	18.0	360	450
742RSL4046	22.0	18.7	350	445
742RSL4048	22.0	20.0	340	440
742RSL4050	22.0	16.1	370	470
743RSL4052	22.0	22.9	330	420
744RSL4054	22.1	22.6	320	420
744RSL4056	22.1	23.3	330	415
744RSL4058	22.1	24.3	330	415
744FSL4060	22.1	17.0	350	470
744FSL4062	22.1	19.5	330	440

Model Number Medium Volts	Exciter Field Resistance Ohms @ 25°C	Exciter Field Volts F1 & F2 at Regulator No Load ^① 3300 Volts	No Load Output Voltage W/Fixed Excitation High Wye Connection ^③	
			12V DC	24V DC
573FSM4352	23.0	21.2	2600	3400
573FSM4354	23.0	18.2	2700	3600
574FSM4356	23.0	18.4	2700	3600
574FSM4358	23.0	15.7	2800	3800
741FSM4360	22.0	15.4	3000	3800
742FSM4364	22.0	14.5	3000	3900
742FSM4366	22.0	15.6	2800	3800
743FSM4368	22.1	15.5	2800	3900
743FSM4370	22.1	15.5	2900	3800
744FSM4374	22.1	16.8	2700	3800
744FSM4376	22.1	16.8	2700	3800

NOTES: ① For rated load exciter field volts – see generator nameplate; ② For low wye connection: divide value shown in table by 2; For high delta connection: divide value shown in table by 1.732; ③ For delta connection: divide value shown in table by 1.732.

Specifications

**Table 12-5: Resistance Values
Main Windings
Nominal Cold (25°C)
Resistance in Ohms**

Base Model Low Voltage	Winding H-SG-	Main Stator ^①	Main Rotor
431RSL4005	430049	.0855	.153
431RSL4007	430048	.0648	.173
432RSL4009	430046	.0418	.190
432RSL4011	430018	.0410	.186
432RSL4013	430015	.0370	.189
432RSL4015	430017	.0260	.225
432RSL4017	430016	.0240	.226
433RSL4019	430042	.0140	.286
433RSL4021	430039	.0137	.297
572RSL4024	570078	.0132	.376
572RSL4027	570072	.0126	.398
572RSL4028	570080	.0092	.423
572RSL4030	570074	.0089	.426
573RSL4032	570075	.0074	.472
573RSL4034	570076	.0059	.507
574RSL4036	570077	.0049	.584
574RSL4038	570069	.0048	.601
575RSL4044	570111	.0030	.704
740RSL4046	570111	.0030	.704
741RSL4045	740062	.0045	.692
742RSL4046	740042	.0036	.748
742RSL4048	740043	.0030	.776
742RSL4050	740051	.0023	.889
743RSL4052	740045	.0018	.979
744RSL4054	740046	.0015	1.100
744RSL4056	740066	.0012	1.250
744RSL4058	740066	.0012	1.250
744FSL4060	740306	.0026	.892
744FSL4062	740307	.0018	1.044

Base Model Medium Voltage	Winding H-SG-	Main Stator ^①	Main Rotor
573FSM4352	570213	1.030	.383
573FSM4354	570214	.854	.411
574FSM4356	570215	.568	.508
741FSM4360	740230	.277	.667
742FSM4364	740204	.233	.768
742FSM4366	740206	.151	.888
743FSM4368	740207	.127	.954
743FSM4370	740208	.101	1.053
744FSM4374	740240	.072	1.196
744FSM4376	740260	.072	1.196

NOTES: ① Main stator values shown are line to line on the high wye connection.
For low wye connection, divide value shown in table by 4.

**Table 12-6: Resistance Values
Exciter Windings
Nominal Cold (25°C)
Resistance in Ohms**

Low Voltage	Exciter Stator (Field)	Exciter Rotor (Armature)	PMG Stator
430 Frames	22.5	0.022	2.1
570 Frames	23.0	0.045	2.1
740 Frames	23.0	0.045	2.1
741 Frames	22.0	0.043	2.1
742 Frames	22.0	0.043	2.1
743 Frames	22.0	0.043	2.1
744 Frames	22.1	0.048	2.1

Medium Voltage	Exciter Stator (Field)	Exciter Rotor (Armature)	PMG Stator
570 Frames	23.0	0.070	2.1
740 Frames	23.0	0.070	2.1
741 Frames	22.0	0.043	2.1
742 Frames	22.0	0.043	2.1
743 Frames	22.1	0.048	2.1

Generator Formulas

Generator Formulas^①

To Find	Known Values	Three Phase
kWe	Volts, Current, Power Factor	$\frac{E \times I \times 1.73 \times PF}{1000} = kVA \times PF$
kVA	Volts, Current	$\frac{E \times I \times 1.73}{1000} = \frac{kWe}{PF}$
RkVA	Volts, Current, Power Factor	$\frac{E \times I \times 1.73 \times \sqrt{1 - (PF)^2}}{1000}$
HP – Engine Output	Generator kWe Generator Efficiency Radiator Cooling Fan HP Battery Charging Generator HP	$\frac{kWe}{Efficiency \times .746} + \frac{Rad. Cooling Fan HP}{.746} + \frac{Bat. Chg. Gen. HP}{.746}$
kWe – Required for Motor	Motor HP, Eff.	$\frac{HP \times .746}{Efficiency}$
kVA – Required for Motor	Motor HP, Eff., Power Factor	$\frac{HP \times .746}{Efficiency \times PF}$
Amps	HP, Volts	$\frac{HP \times .746}{1.73 \times E \times Efficiency \times PF}$
Amps	kWe, Volts, Power Factor	$\frac{kWe \times 1000}{E \times 1.73 \times PF}$
Amps	kVA, Volts	$\frac{kVA \times 1000}{E \times 1.73}$
Frequency (Hz)	rpm, Poles	$\frac{rpm \times Poles}{2 \times 60}$
Poles	Hz, rpm	$\frac{2 \times 60 \times Hz}{rpm}$
rpm	Hz, Poles	$\frac{2 \times 60 \times Hz}{Poles}$

① E = Volts
I = Current (Amps)
PF = Power Factor



Warnings & Cautions



IMPORTANT INFORMATION Please Read Carefully



This catalog is not intended to provide operational instructions. Appropriate Marathon Electric instructions provided with the motor and precautions attached to the motor should be read carefully prior to installation, operation and/or maintenance of the equipment. Injury to personnel or motor failure may be caused by improper installation, maintenance or operation.

The following  and  information is supplied to you for your protection and to provide you with many years of trouble free and safe operation of your Marathon Electric product:



- Disconnect power and lock out driven equipment before working on a motor.
- Always keep hands and clothing away from moving parts.
- The lifting support on the motor is not to be used to lift the entire machine. Only the motor attached directly to the support may be safely lifted by the support.
- Install and ground per local and national codes.
- Discharge all capacitors before servicing a single phase motor.
- Misapplication of a motor in a hazardous environment can cause fire or an explosion and result in serious injury. Only the end user, local authority having jurisdiction, and/or insurance underwriter are qualified to identify the appropriate class(es), group(s), division and temperature code. Marathon Electric personnel cannot evaluate or recommend what motors may be suitable for use in hazardous environments. If a motor is nameplated for hazardous locations, do not operate the motor without all of the grease and drain plugs installed.
- Never attempt to measure the temperature rise of a motor by touch. Temperature rise must be measured by thermometer, resistance, imbedded detector or thermocouple.
- Motors with automatic reset thermal protectors will automatically restart when the protector temperature drops sufficiently. Do not use motors with automatic reset thermal protectors in applications where automatic restart will be hazardous to personnel or equipment.
- Motors with manual reset thermal protectors may start unexpectedly after the protector trips when the surrounding air is at +20°Fahrenheit or lower. If the manual reset protector trips, disconnect motor from its power supply. After the protector cools (five minutes or more), it can be reset and power may be applied to the motor.
- Connect all protective device leads, marked P1, P2, etc., per instructions supplied with the motor.
- Operation of a motor at other than its nameplate rating may result in fire, damage to equipment or serious injury to personnel.
- For safety, Buyer or User should provide protective guards over all shaft extensions and any moving apparatus mounted thereon. The User is responsible for checking all applicable safety codes in his area and providing suitable guards. Failure to do so may result in bodily injury and/or damage to equipment.



- Consult qualified personnel with questions and all electrical repairs must be performed by trained and qualified personnel only.
- For motors nameplated as "belted duty only", do not operate the motor without belts properly installed.
- Motors and/or driven equipment should not be operated faster than their rated speed.
- For inverter applications, follow the inverter manufacturer's installation guidelines.
- Make sure the motor is properly secured and aligned before operation.

Resale Of Goods

Important Information

Resale of Goods

In the event of the resale of any of the goods, in whatever form, Resellers/Buyers will include the following language in a conspicuous place and in a conspicuous manner in a written agreement covering such sale:

The manufacturer makes no warranty or representations, express or implied, by operation of law or otherwise, as to the merchantability or fitness for a particular purpose of the goods sold hereunder. Buyer acknowledges that it alone has determined that the goods purchased hereunder will suitably meet the requirements of their intended use. In no event will the manufacturer be liable for consequential, incidental or other damages. Even if the repair or replacement remedy shall be deemed to have failed of its essential purpose under Section 2-719 of the Uniform Commercial Code, the manufacturer shall have no liability to Buyer for consequential damages.

Resellers/Buyers agree to also include this entire document including the warnings and cautions above in a conspicuous place and in a conspicuous manner in writing to instruct users on the safe usage of the product.

This information should be read together with all other printed information supplied by Marathon Electric.

For more information contact: Regal Beloit America, Inc., a subsidiary of Regal-Beloit Corporation, 100 E. Randolph St., Wausau, WI 54401 Phone: 715-675-3311 or Fax: 715-675-8030.

marathon™

Generators

100 E. Randolph Street
PO Box 8003
Wausau, WI 54402-8003 U.S.A.
PH: 715-675-3359
FAX: 715-675-8026

www.marathonelectric.com

A Regal Brand



REGAL

www.regalbeloit.com