



TECHNICAL SERVICE MANUAL

GENERAL PURPOSE PUMPS
SERIES 32 and 432
SIZES G - N

SECTION TSM 312
PAGE 1
ISSUE E

CONTENTS

Introduction	1
Special Information	2
Maintenance	2
Disassembly	6
Assembly	6-7
Installation of Carbon Graphite Bushings	7
Pressure Relief Valve Instructions	7-8

INTRODUCTION

The illustrations used in this manual are for identification purposes only and cannot be used for ordering parts. Obtain a parts list from the factory or a Viking® representative. Always give complete name of part, part number and material with model number and serial number of pump when ordering repair parts. The unmounted pump or pump unit model number and serial number are on the nameplate.

In the Viking model number system, basic size letters are combined with series number (32 and 432), indicating both unmounted or mounted pump unit.

UNMOUNTED PUMP AND UNIT MODEL NUMBERS

Model Number Chart

UNMOUNTED PUMP		UNITS
PACKED	MECH. SEAL	
G32	G432	Units Are Designed By The Un-Mounted Pump Model Numbers Followed By A Letter Indicating Drive Style. V = V-belt D = Direct Drive B = Bracket Mounted
H32	H432	
HL32	HL432	
J32		
K32		
KK32		
L32		
LQ32		
LL32		
Q32		
M32		
N32		



FIGURE 1 - G Size Unmounted Pump

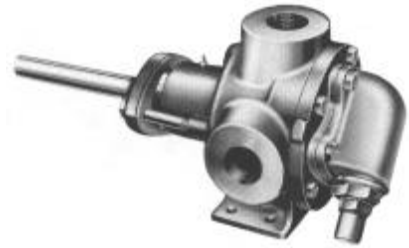

FIGURE 2 - H and HL Sizes Unmounted Pump



FIGURE 3 - J, K, KK, and L Sizes Unmounted Pump
(Shown without pressure relief valve)



FIGURE 4 - LQ, LL, M and N Sizes Unmounted Pump



This manual deals only with Series 32 and 432 General Purpose Pumps. Refer to Figures 1 thru 12 for general configuration and nomenclature used in this manual. Pump specifications and recommendations are listed in Catalog Section 310, Series 32 and 432 General Purpose Pumps.

SPECIAL INFORMATION

DANGER

BEFORE OPENING ANY VIKING PUMP LIQUID CHAMBER (PUMPING CHAMBER, RESERVOIR, RELIEF VALVE ADJUSTING CAP FITTING ETC.) BE SURE:

1. THAT ANY PRESSURE IN CHAMBER HAS BEEN COMPLETELY VENTED THROUGH SUCTION OR DISCHARGE LINES OR OTHER APPROPRIATE OPENINGS OR CONNECTIONS.
2. THAT THE DRIVING MEANS (MOTOR, TURBINE, ENGINE, ETC.) HAS BEEN "LOCKED OUT" OR MADE NON-OPERATIONAL SO THAT IT CANNOT BE STARTED WHILE WORK IS BEING DONE ON PUMP.
3. THAT YOU KNOW WHAT LIQUID THE PUMP HAS BEEN HANDLING AND THE PRECAUTIONS NECESSARY TO SAFELY HANDLE THE LIQUID. OBTAIN A MATERIAL SAFETY DATA SHEET (MSDS) FOR THE LIQUID TO BE SURE THESE PRECAUTIONS ARE UNDERSTOOD.

FAILURE TO FOLLOW ABOVE LISTED PRECAUTIONARY MEASURES MAY RESULT IN SERIOUS INJURY OR DEATH.

ROTATION: Viking pumps operate equally well in a clockwise or counterclockwise rotation. Shaft rotation determines which port is suction and which is discharge. Port in area where pumping elements (gear teeth) come out of mesh is suction port.

PRESSURE RELIEF VALVES:

1. Viking pumps are positive displacement pumps and must be provided with some sort of pressure protection. This may be a relief valve mounted directly on the pump, an inline pressure relief valve, a torque limiting device or a rupture disk.
2. There are relief valve options available on those pump models designed to accept a relief valve. Options may include a return to tank relief valve and a jacketed relief valve. Pumps equipped with a jacketed head plate are generally not available with a relief valve.
3. If pump rotation is reversed during operation, pressure protection must be provided on *both* sides of pump.

4. Relief valve adjusting screw cap must *always* point towards suction side of pump. If pump rotation is reversed, remove pressure relief valve and turn end for end. Refer to Figures 1, 2, 3 and 4, page 1.
5. Pressure relief valves cannot be used to control pump flow or regulate discharge pressure.

For additional information on pressure relief valves, refer to Technical Service Manual TSM000 and Engineering Service Bulletin ESB-31.

MAINTENANCE

Series 32 and 432 pumps are designed for long, trouble-free service life under a wide variety of application conditions with a minimum of maintenance. The points listed below will help provide long service life.

LUBRICATION: Periodic external lubrication should be applied slowly with a hand gun at all lubrication fittings provided. A good quality of general purpose grease is satisfactory in the majority of cases, however, applications involving very high or low temperatures may require other types of lubricants. Suggested frequency of lubrication is once every 500 hours of operation. Do not over-grease. Refer to Engineering Service Bulletin ESB-515. Consult factory with specific lubrication questions.

PACKING ADJUSTMENT: New packed pumps require initial packing adjustment to control leakage as packing "runs in". Make initial adjustments carefully and do not over-tighten packing gland. After initial adjustment, inspection will reveal need for packing gland adjustment or packing replacement. Refer to instructions under Disassembly, page 6, and Assembly, page 6, regarding repacking pump.

CLEANING PUMP: Keep pump as clean as possible. This will facilitate inspection, adjustment and repair work and help prevent overlooking a dirt covered grease fitting.

STORAGE: If pump is to be stored, or not used for six months or more, pump must be drained and a light coat of non-detergent SAE 30 weight oil must be applied to all internal pump parts. Lubricate fittings and apply grease to pump shaft extension. Viking suggests rotating pump shaft by hand one complete revolution every 30 days to circulate the oil.

SUGGESTED REPAIR TOOLS: The following tools must be available to properly repair Series 32 and 432 pumps. These tools are in addition to standard mechanics' tools such as open end wrenches, pliers, screw drivers, etc. Most of the items can be obtained from an industrial supply house.

1. Soft Headed hammer
2. Allen wrenches (some mechanical seals and set collars)
3. Packing hooks, flexible (packed pumps)
Small for 0.25 inch and 0.31 inch cross section packing
Large for 0.38 inch and up cross section packing
4. Brass bar
5. Arbor press

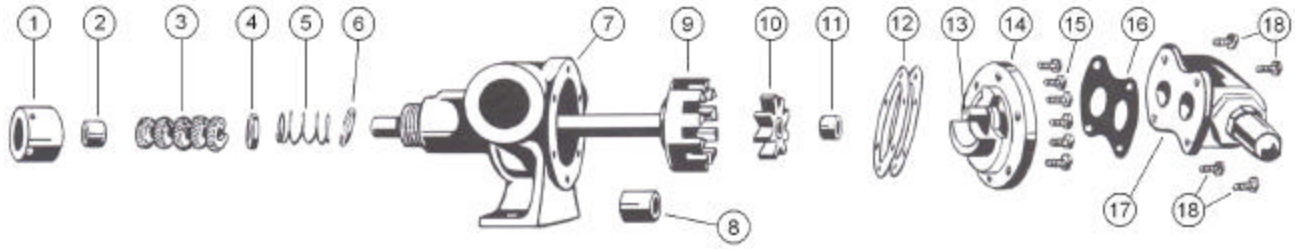

FIGURE 5 – EXPLODED VIEW MODEL G32 PUMP

ITEM	NAME OF PART	ITEM	NAME OF PART	ITEM	NAME OF PART	ITEM	NAME OF PART
1	Packing Nut	6	Packing Spring Washer	11	Idler Bushing	16	Relief Valve Gasket
2	Outer Packing Gland	7	Casing and Bushing	12	Head Gasket	17	Relief Valve
3	Packing	8	Casing Bushing	13	Idler Pin	18	Capscrew for Valve
4	Inner Packing Gland	9	Rotor and Shaft	14	Head and Idler Pin		
5	Packing Spring	10	Idler and Bushing	15	Capscrew for Head		

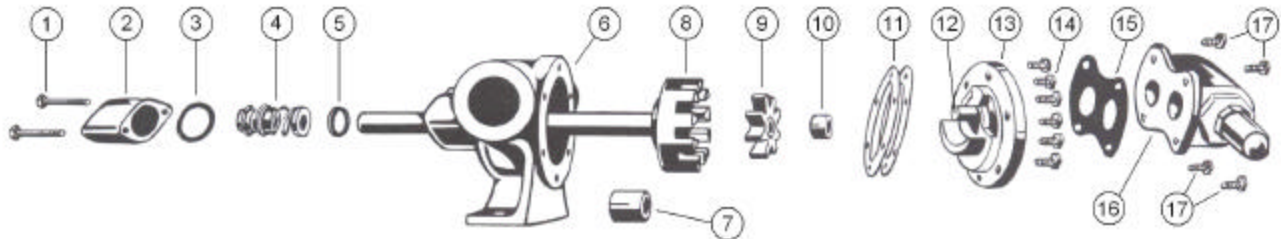

FIGURE 6 – EXPLODED VIEW MODEL G432 PUMP

ITEM	NAME OF PART	ITEM	NAME OF PART	ITEM	NAME OF PART	ITEM	NAME OF PART
1	Capscrew for End Cap	6	Casing and Bushing	11	Head Gasket	16	Relief Valve
2	End Cap	7	Casing Bushing	12	Idler Pin	17	Capscrew for Valve
3	Gasket for End Cap	8	Rotor and Shaft	13	Head and Idler Pin		
4	Mechanical Seal (Complete)	9	Idler and Bushing	14	Capscrew for Head		
5	Set Collar with Setscrew	10	Idler Bushing	15	Relief Valve Gasket		

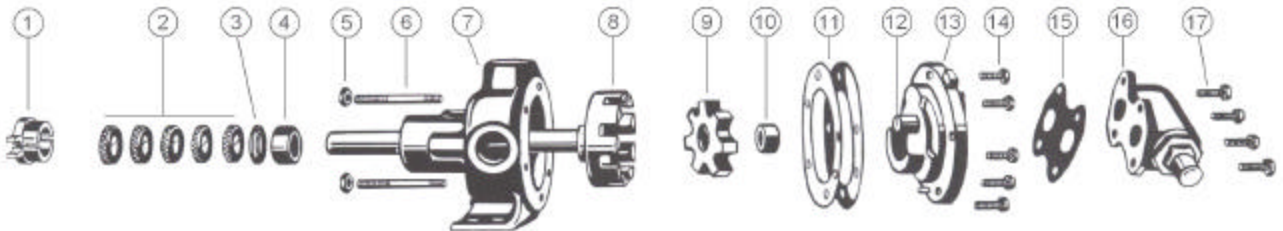

FIGURE 7 – EXPLODED VIEW MODEL H AND HL32 PUMP

ITEM	NAME OF PART	ITEM	NAME OF PART	ITEM	NAME OF PART	ITEM	NAME OF PART
1	Two Piece Packing Gland	6	Packing Gland Stud	11	Head Gasket	16	Relief Valve
2	Packing	7	Casing and Bushing	12	Idler Pin	17	Capscrew for Valve
3	Packing Retainer Washer	8	Rotor and Shaft	13	Head and Idler Pin		
4	Casing Bushing	9	Idler and Bushing	14	Capscrew for Head		
5	Packing Gland Nut	10	Idler Bushing	15	Relief Valve Gasket		

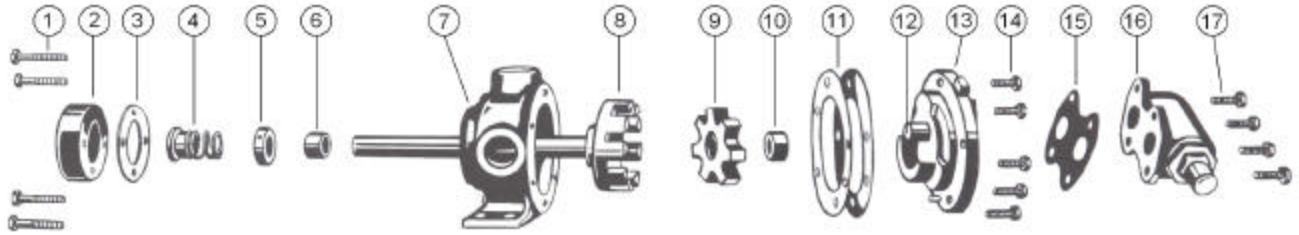

FIGURE 8 – EXPLODED VIEW MODEL H AND HL432 PUMP

ITEM	NAME OF PART	ITEM	NAME OF PART	ITEM	NAME OF PART	ITEM	NAME OF PART
1	Capscrew for End Cap	6	Casing Bushing	11	Head Gasket	16	Relief Valve
2	End Cap	7	Casing and Bushing	12	Idler Pin	17	Capscrew for Valve
3	Gasket for End Cap	8	Rotor and Shaft	13	Head and Idler Pin		
4	Mechanical Seal	9	Idler and Bushing	14	Capscrew for Head		
5	Set Collar with Setscrew	10	Idler Bushing	15	Relief Valve Gasket		

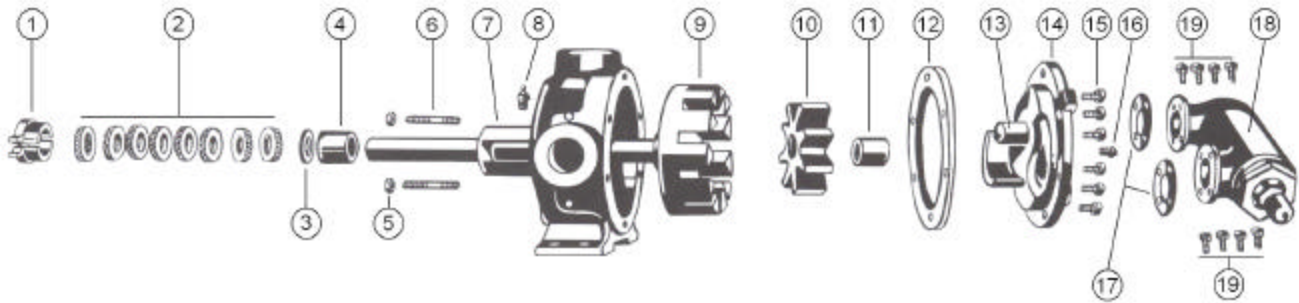

FIGURE 9 – EXPLODED VIEW MODEL J32, K32, KK32 AND L32 PUMP

ITEM	NAME OF PART	ITEM	NAME OF PART	ITEM	NAME OF PART	ITEM	NAME OF PART
1	Two Piece Packing Gland	6	Packing Gland Stud	11	Idler Bushing	16	Pipe Plug
2	Packing	7	Casing and Bushing	12	Head Gasket	17	Relief Valve Gasket
3	Packing Retainer Washer	8	Grease Fitting	13	Idler Pin	18	Relief Valve
4	Casing Bushing	9	Rotor and Shaft	14	Head and Idler Pin	19	Capscrew for Valve
5	Packing Gland Nut	10	Idler and Bushing	15	Capscrew for Head		

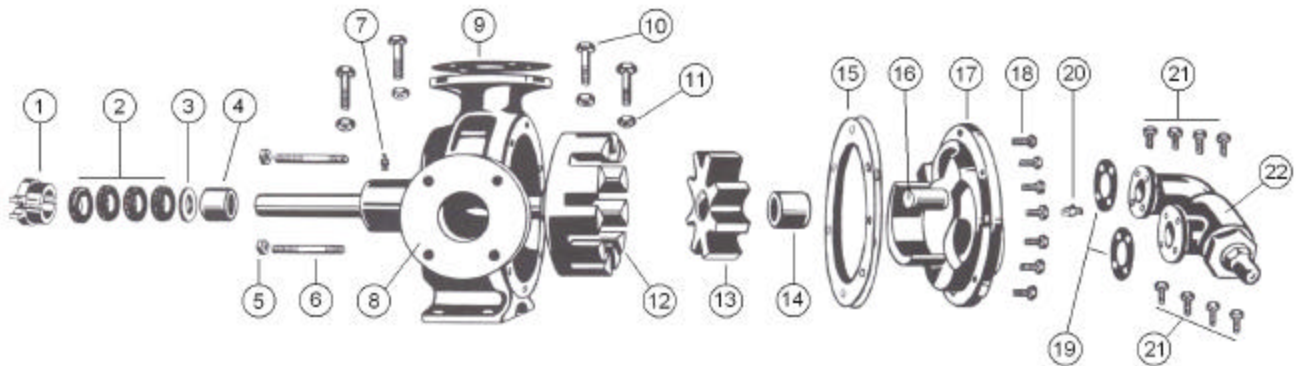

FIGURE 10 – EXPLODED VIEW MODEL LQ32 PUMP

ITEM	NAME OF PART	ITEM	NAME OF PART	ITEM	NAME OF PART	ITEM	NAME OF PART
1	Two Piece Packing Gland	7	Grease Fitting	13	Idler and Bushing	19	Relief Valve Gasket
2	Packing	8	Casing and Bushing	14	Idler Bushing	20	Pipe Plug
3	Packing Retainer Washer	9	Pipe Flange Gasket	15	Head Gasket	21	Capscrew for Valve
4	Casing Bushing	10	Capscrew for Flanges	16	Idler Pin	22	Relief Valve
5	Packing Gland Nut	11	Hex Nut for Flanges	17	Head and Idler Pin		
6	Packing Gland Stud	12	Rotor and Shaft	18	Capscrew for Head		

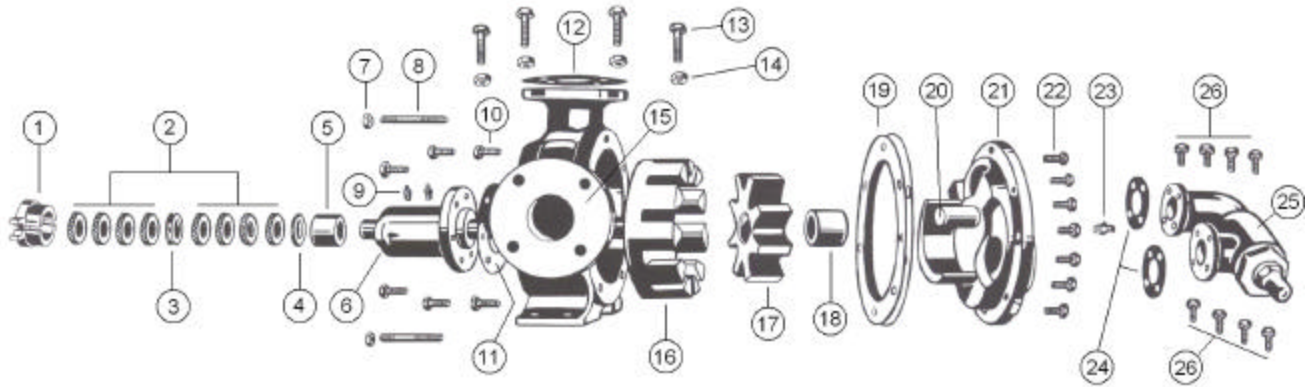

FIGURE 11 – EXPLODED VIEW MODEL LL32 PUMP

ITEM	NAME OF PART	ITEM	NAME OF PART	ITEM	NAME OF PART	ITEM	NAME OF PART
1	Two Piece Packing Gland	8	Packing Gland Stud	15	Casing	22	Capscrew for Head
2	Packing	9	Grease Fitting	16	Rotor and Shaft	23	Pipe Plug
3	Lantern Ring	10	Capscrew for Rotor Bearing Sleeve	17	Idler and Bushing	24	Relief Valve Gasket
4	Packing Retainer Washer	11	Gasket for Rotor Bearing Sleeve	18	Idler Bushing	25	Relief Valve
5	Bushing for Rotor Bearing Sleeve	12	Pipe Flange Gasket	19	Head Gasket	26	Capscrew for Valve
6	Rotor Bearing Sleeve and Bushing	13	Capscrew for Flanges	20	Idler Pin		
7	Packing Gland Nut	14	Nut for Flanges	21	Head and Idler Pin		

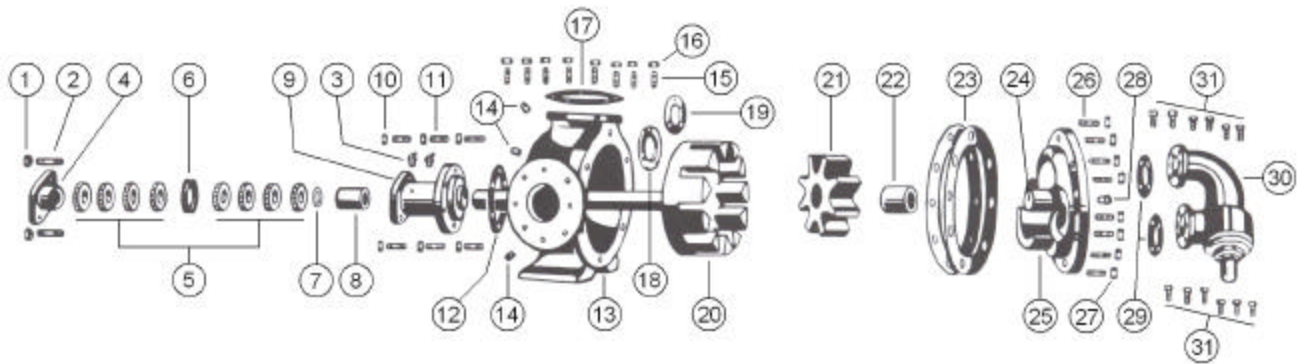

FIGURE 12 – EXPLODED VIEW MODEL O32, M32 AND N32 PUMP

ITEM	NAME OF PART	ITEM	NAME OF PART	ITEM	NAME OF PART	ITEM	NAME OF PART
1	Packing Gland Nut	9	Rotor Bearing Sleeve and Bushing	17	Pipe Flange Gasket	25	Head and Idler Pin
2	Packing Gland Stud	10	Nut for Rotor Bearing Sleeve	18	Rotor Bearing Sleeve Washer	26	Stud for Head
3	Grease Fitting	11	Stud for Rotor Bearing Sleeve	19	Rotor Thrust Washer	27	Nut for Head
4	Packing Gland	12	Gasket for Rotor Bearing Sleeve	20	Rotor and Shaft	28	Pipe Plug
5	Packing	13	Casing	21	Idler and Bushing	29	Relief Valve Gasket
6	Lantern Ring	14	Pipe Plug	22	Idler Bushing	30	Relief Valve
7	Packing Retainer Washer	15	Stud for Flanges	23	Head Gasket	31	Capscrew for Valve
8	Bushing for Rotor Bearing Sleeve	16	Nut for Flanges	24	Idler Pin		

DISASSEMBLY

DANGER

BEFORE OPENING ANY VIKING PUMP LIQUID CHAMBER (PUMPING CHAMBER, RESERVOIR, RELIEF VALVE ADJUSTING CAP FITTING ETC.) BE SURE:

1. THAT ANY PRESSURE IN CHAMBER HAS BEEN COMPLETELY VENTED THROUGH SUCTION OR DISCHARGE LINES OR OTHER APPROPRIATE OPENINGS OR CONNECTIONS.
2. THAT THE DRIVING MEANS (MOTOR, TURBINE, ENGINE, ETC.) HAS BEEN "LOCKED OUT" OR MADE NON-OPERATIONAL SO THAT IT CANNOT BE STARTED WHILE WORK IS BEING DONE ON PUMP.
3. THAT YOU KNOW WHAT LIQUID THE PUMP HAS BEEN HANDLING AND THE PRECAUTIONS NECESSARY TO SAFELY HANDLE THE LIQUID. OBTAIN A MATERIAL SAFETY DATA SHEET (MSDS) FOR THE LIQUID TO BE SURE THESE PRECAUTIONS ARE UNDERSTOOD.

FAILURE TO FOLLOW ABOVE LISTED PRECAUTIONARY MEASURES MAY RESULT IN SERIOUS INJURY OR DEATH.

1. Refer to figures 5 through 12 for name of parts.
2. Mark head and casing before disassembly to insure proper reassembly. The idler pin, which is offset in pump head, must be positioned toward and equal distance between port connections to allow for proper flow of liquid through pump.
3. Remove the head capscrews.
NOTE: The four valve capscrews, valve and gasket must be removed from the GG models before the six head capscrews are removed.
4. Remove head from pump. Do not allow idler to fall from idler pin. Tilt top of head back when removing to prevent this. Avoid damaging head gasket set, all gaskets are required to maintain end clearance.
5. Remove idler and bushing assembly. If idler bushing needs replacing, see step 11.

Remove the packing gland.

If you have a mechanical seal pump, remove the end cap and the mechanical seal is exposed. Remove the mechanical seal by sliding off the end of the shaft. Loosen the setscrew in the set collar and remove it.

CAUTION: Older pumps may have snap ring on shaft - remove the snap ring before removing rotor and shaft. Carefully remove the rotor and shaft from the pump to avoid damaging the casing or rotor bearing sleeve bushing.

THRUST WASHERS: Rotor thrust washer and rotor bearing sleeve thrust washer used in O, M and N size pumps should be removed, examined for excessive wear and replaced if necessary. These thrust washers are located on the hub of the rotor and the casing end of rotor bearing sleeve.

If it is necessary to replace the casing, rotor bearing sleeve or idler bushing and/or repack the pump, remove the old packing and lantern ring and packing retainer washer. Some pumps don't have a lantern ring.

Clean all parts thoroughly and examine wear and damage.

Check bushings, and idler pin and replace if necessary. Check all other parts for nicks, burrs, excessive wear and replace if necessary.

ASSEMBLY

1. Install casing or rotor bearing sleeve bushing. If bracket bushing has a lubrication groove, install bushing with groove at 12:00 o'clock position in bracket. If carbon graphite, refer to Installation of Carbon Graphite Bushings, page 7.
2. Thrust washers used in Q, M and N size pumps should be assembled on the rotor hub and rotor bearing sleeve. Put the plain washer on the two locating pins on the rotor hub. Put the grooved face washer on the pins on the rotor bearing sleeve with the grooved face toward the rotor.
3. Coat shaft of rotor shaft assembly with non-detergent SAE 30 weight oil. Start end of shaft in bracket bushing turning from right to left, slowly pushing rotor into casing.
4. Place the head gaskets on the head. The proper amount of gaskets should be used to provide the necessary end clearance within the pump so it turns freely with no appreciable end play. The Gasket Table (Figure 13) gives the normal amount of gaskets used on each pump.
5. Coat idler pin with non-detergent SAE 30 weight oil and place idler and bushing on idler pin in head. If replacing carbon graphite bushing, refer to installation of Carbon Graphite Bushings, page 7.
6. The head can now be assembled on the pump. Tilt the top of the head away from the pump slightly until the crescent enters the inside diameter of the rotor and rotate the idler until its teeth mesh with the rotor teeth. Do not damage the head gaskets. Tighten the head capscrews or nuts and then check the end clearance. If the pump shaft cannot be rotated, more gaskets must be added. If, however, the pump has any noticeable end play, remove enough gaskets so the pump has no appreciable end play but still turns freely.

ASSEMBLY

PUMP MODEL	NORMAL AMOUNT USED	ONE SET OF GASKETS CONSISTS OF THE FOLLOWING	STANDARD END CLEARANCE
G32 G432	.010" - .015"	2 - .006" 1 - .005" 2 - .002"	.003"
H, HL32 H, HL432	.010" - .015"	2 - .006" 2 - .002"	.003"
J, K, KK32	.015" - .020"	1 - .015" 1 - .010" 1 - .006"	.005"
L, LQ, LL32	.025" - .030"	1 - .015" 1 - .010" 1 - .006"	.005"
Q32	.012" - .030"	2 - .015" 1 - .006"	.010"
M, N32	.015" - .036"	2 - .015" 1 - .006"	.015"

FIGURE 13 – GASKET TABLE

- Place packing retainer washer in bottom of packing chamber and pack pump with new packing. Use packing suitable for liquid being pumped. Install packing, staggering the joints from one side of shaft to other. Lubricate packing rings with oil, grease or graphite to aid assembly. A length of pipe will help to seat each packing ring.

NOTE: If the pump has a lantern ring it must be located below the grease fitting. The grease fitting may be removed to facilitate positioning of the lantern ring.

- Install packing gland, capscrews and nuts.

DANGER

BEFORE STARTING PUMP, BE SURE ALL DRIVE EQUIPMENT GUARDS ARE IN PLACE.

FAILURE TO PROPERLY MOUNT GUARDS MAY RESULT IN SERIOUS INJURY OR DEATH.

NOTE: Pump may be equipped with a 2-piece split packing gland which allows installation of packing gland with rotor in place. See Figure 14.

SPRING WIRE RETAINER CLIP (2 REQUIRED)

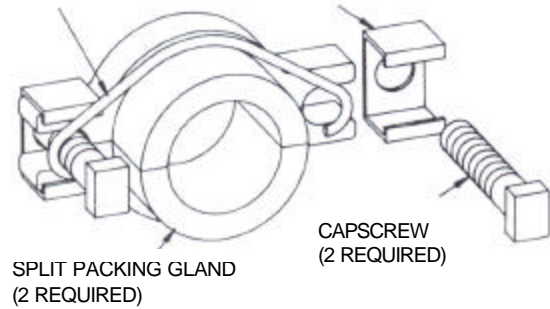

FIGURE 14

MECHANICAL SEAL OPTION

Install the mechanical seal: Place the set-collar on the shaft and tighten setscrew. See Figure 15 for set-collar location.

The seal used in this pump is simple to install and good performance will result if care is taken during installation.

The principle of the mechanical seal is contact between the rotary and stationary members. These parts are lapped to a high finish and their seating effectiveness depends on complete contact.

- Never touch sealing faces with anything except clean hands or clean cloth. Minute particles can scratch the seal faces and cause leakage.
- The spring washer and spring must be put on the shaft first and in that order. (See Figure 15).
- Spread a film of lubricating oil on the inside diameter of the synthetic rubber bellows. Check the end of the pump shaft for sharp burrs or edges which might cut the bellows. Slide the seal rotary member over the shaft and up against the spring.
- Coat the synthetic rubber seal seat with lubricating oil and push the seal seat into the end cap. Put the end cap gasket on the end of the casing. Slide end cap over the shaft and flush both the seal seat and carbon wear ring in the seal rotary member with oil. Push the end cap up until the mating surfaces or the seal meet. Install the capscrews and tighten evenly.

MECHANICAL SEAL OPTION

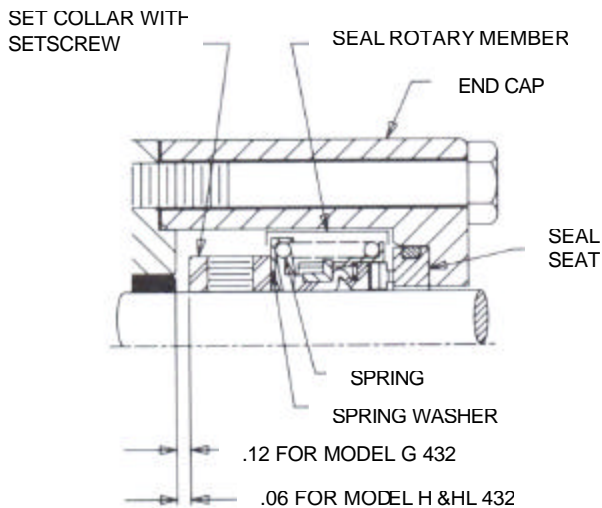

FIGURE 15 – SECTIONAL VIEW, SEAL AREA

INSTALLATION OF CARBON GRAPHITE BUSHINGS

When installing carbon graphite bushings, extreme care must be taken to prevent breaking. Carbon graphite is a brittle material and easily cracked. If cracked, the bushing will quickly disintegrate. Using a lubricant and adding a chamfer on the bushing and the mating part will help in installation. The additional precautions listed below must be followed for proper installation:

1. A press must be used for installation.
2. Be certain bushing is started straight.
3. Do not stop pressing operation until bushing is in proper position. starting and stopping will result in a cracked bushing.
4. Check bushing for cracks after installation.

Carbon graphite bushings with extra interference fits are frequently furnished for high temperature operation. These bushings must be installed by a shrink fit.

1. Heat bracket or idler to 750°F.
2. Install cool bushings with a press.
3. If facilities are not available to reach 750°F. temperature, it is possible to install with 450°F. temperature; however, the lower the temperature, the greater the possibility of cracking bushing.

Consult factory with specific questions on high temperature applications. Refer to Engineering Service Bulletin ESB-3.

PRESSURE RELIEF VALVE INSTRUCTIONS

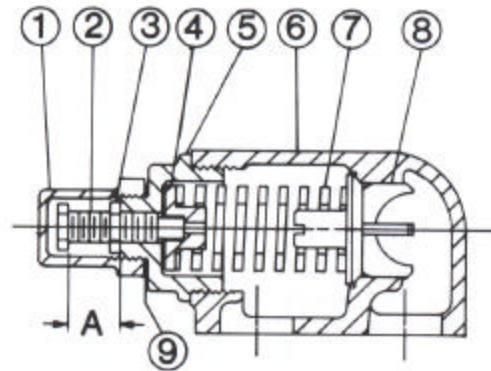

FIGURE 16 - Size G, H and HL

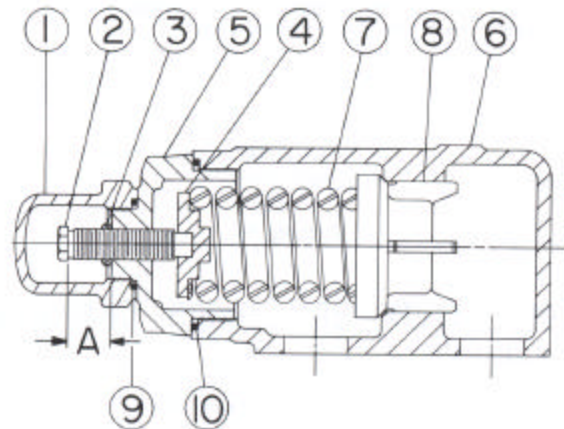

FIGURE 17 - Size AK and AL

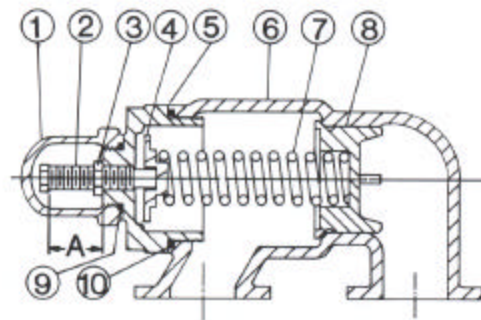

FIGURE 18 - Size K, KK, L, LQ and LL

VALVE - LIST OF PARTS

1. Valve Cap	6. Valve Body
2. Adjusting Screw	7. Valve Spring
3. Lock Nut	8. Poppet
4. Spring Guide	9. Cap Gasket
5. Bonnet	10. Bonnet

DISASSEMBLY

DANGER

BEFORE OPENING ANY VIKING PUMP LIQUID CHAMBER (PUMPING CHAMBER, RESERVOIR, RELIEF VALVE ADJUSTING CAP FITTING ETC.) BE SURE:

1. THAT ANY PRESSURE IN CHAMBER HAS BEEN COMPLETELY VENTED THROUGH SUCTION OR DISCHARGE LINES OR OTHER APPROPRIATE OPENINGS OR CONNECTIONS.
2. THAT THE DRIVING MEANS (MOTOR, TURBINE, ENGINE, ETC.) HAS BEEN "LOCKED OUT" OR MADE NON-OPERATIONAL SO THAT IT CANNOT BE STARTED WHILE WORK IS BEING DONE ON PUMP.
3. THAT YOU KNOW WHAT LIQUID THE PUMP HAS BEEN HANDLING AND THE PRECAUTIONS NECESSARY TO SAFELY HANDLE THE LIQUID. OBTAIN A MATERIAL SAFETY DATA SHEET (MSDS) FOR THE LIQUID TO BE SURE THESE PRECAUTIONS ARE UNDERSTOOD.

FAILURE TO FOLLOW ABOVE LISTED PRECAUTIONARY MEASURES MAY RESULT IN SERIOUS INJURY OR DEATH.

Mark valve and head before disassembly to insure proper reassembly.

1. Remove valve cap.
2. Measure and record length of extension of adjusting screw. Refer to "A" on Figures 17, 18 and 19.
3. Loosen locknut and back out adjusting screw until spring pressure is released.
4. Remove bonnet, spring guide, spring and poppet from valve body. Clean and inspect all parts for wear or damage and replace as necessary.

ASSEMBLY

Reverse procedures outlined under Disassembly. If valve is removed for repairs, be sure to replace in same position. Relief valve adjusting screw cap must *always* point towards suction side of pump. If pump rotation is reversed, remove relief valve and turn end for end. Refer to Figures 1, 2, 3 and 4, page 1.

DANGER

BEFORE STARTING PUMP, BE SURE ALL DRIVE EQUIPMENT GUARDS ARE IN PLACE.

FAILURE TO PROPERLY MOUNT GUARDS MAY RESULT IN SERIOUS INJURY OR DEATH.

PRESSURE ADJUSTMENT

If a new spring is installed or if pressure setting of pressure relief valve is to be changed from that which the factory has set, the following instructions must be carefully followed.

1. Carefully remove valve cap which covers adjusting screw.

Loosen locknut which locks adjusting screw so pressure setting will not change during operation of pump.
2. Install a pressure gauge in discharge line for actual adjustment operation.
3. Turn adjusting screw in to increase pressure and out to decrease pressure.
4. With discharge line closed at a point beyond pressure gauge, gauge will show maximum pressure valve will allow while pump is in operation.

IMPORTANT

In ordering parts for pressure relief valve, always give model number and serial number of pump as it appears on nameplate and name of part wanted. When ordering springs, be sure to give pressure setting desired.



TECHNICAL SERVICE MANUAL

GENERAL PURPOSE PUMPS
SERIES 32 and 432
SIZES G - N

SECTION TSM 312
PAGE 10
ISSUE E



WARRANTY

Viking warrants all products manufactured by it to be free from defects in workmanship or material for a period of one (1) year from date of startup, provided that in no event shall this warranty extend more than eighteen (18) months from the date of shipment from Viking. If, during said warranty period, any products sold by Viking prove to be defective in workmanship or material under normal use and service, and if such products are returned to Viking's factory at Cedar Falls, Iowa, transportation charges prepaid, and if the products are found by Viking to be defective in workmanship or material, they will be replaced or repaired free of charge, FOB. Cedar Falls, Iowa.

Viking assumes no liability for consequential damages of any kind and the purchaser by acceptance of delivery assumes all liability for the consequences of the use or misuse of Viking products by the purchaser, his employees or others. Viking will assume no field expense for service or parts unless authorized by it in advance.

Equipment and accessories purchased by Viking from outside sources which are incorporated into any Viking product are warranted only to the extent of and by the original manufacturer's warranty or guarantee, if any.

THIS IS VIKING'S SOLE WARRANTY AND IS IN LIEU OF ALL OTHER WARRANTIES, EXPRESSED OR IMPLIED, WHICH ARE HEREBY EXCLUDED, INCLUDING IN PARTICULAR ALL WARRANTIES OF MERCHANTABILITY OR FITNESS FOR A PARTICULAR PURPOSE. No officer or employee of IDEX Corporation or Viking Pump, Inc. is authorized to alter this warranty.

