

10 SERIES

*ELECTRICALLY HEATED,
ROUND DISHMACHINES*



TECHNICAL MANUAL

INSTALLATION MANUAL FOR EXPORT UNITS
SERVICE MANUAL FOR DOMESTIC UNITS

FOR JACKSON MODEL(S):

10A

10AB

10APRB

10U

**HIGHER HOOD
OPTION**



MANUFACTURERS WARRANTY

ONE YEAR LIMITED PARTS & LABOR WARRANTY

ALL NEW JACKSON DISHWASHERS ARE WARRANTED TO THE ORIGINAL PURCHASER TO BE FREE FROM DEFECTS IN MATERIAL OR WORKMANSHIP, UNDER NORMAL USE AND OPERATION FOR A PERIOD OF (1) ONE YEAR FROM DATE OF PURCHASE, BUT IN NO EVENT TO EXCEED (18) EIGHTEEN MONTHS FROM DATE OF SHIPMENT FROM THE FACTORY.

Jackson WWS agrees under this warranty to repair or replace, at its discretion, any original part which fails under normal use due to faulty material or workmanship during the warranty period, providing the equipment has been unaltered, and has been properly installed, maintained and operated in accordance with applicable factory instruction manual furnished with the machine and failure is reported to the authorized service agency within the warranty period. This includes the use of factory specified genuine replacement parts, purchased directly from a Jackson authorized parts distributor or service agency. Use of generic replacement parts may create a hazard and void warranty certification.

The labor to repair or replace such failed part will be paid by Jackson WWS, within the continental United States, Hawaii and Canada, during the warranty period provided a Jackson WWS authorized service agency, or those having prior authorization from the factory, performs the service. Any repair work by persons other than Jackson WWS authorized service agency is the sole responsibility of the customer. Labor coverage is limited to regular hourly rates; overtime premiums and emergency service charges will not be paid by Jackson WWS.

Accessory components not installed by the factory carry a (1) one year parts warranty only. Accessory components such as table limit switches, pressure regulators, pre-rinse units, etc. that are shipped with the unit and installed at the site are included. Labor to repair or replace these components is not covered by Jackson WWS.

This warranty is void if failure is a direct result from shipping, handling, fire, water, accident, misuse, acts of God, attempted repair by authorized persons, improper installation, if serial number has been removed or altered, or if unit is used for purpose other than originally intended.

TRAVEL LIMITATIONS

Jackson WWS limits warranty travel time to (2) two hours and mileage to (100) one hundred miles. Jackson WWS will not pay for travel time and mileage that exceeds this, or any fees such as those for air or boat travel without prior authorization.

WARRANTY REGISTRATION

To register your product go to www.jacksonwws.com or call 1-888-800-5672. Failure to register your product will void the warranty.

REPLACEMENT PARTS WARRANTY

Jackson replacement parts are warranted for a period of 90 days from date of installation or 180 days from the date of shipment from the factory, whichever occurs first.

PRODUCT CHANGES AND UPDATES

Jackson WWS reserves the right to make changes in design and specification of any equipment as engineering or necessity requires.

THIS IS THE ENTIRE AND ONLY WARRANTY OF JACKSON WWS. JACKSON'S LIABILITY ON ANY CLAIM OF ANY KIND, INCLUDING NEGLIGENCE, WITH RESPECT TO THE GOODS OR SERVICES COVERED HEREUNDER, SHALL IN NO CASE EXCEED THE PRICE OF THE GOODS OR SERVICES OR PART THEREOF WHICH GIVES RISE TO THE CLAIM.

THERE ARE NO WARRANTIES, EXPRESSED OR IMPLIED, INCLUDING FOR FITNESS OR MERCHANTABILITY, THAT ARE NOT SET FORTH HEREIN, OR THAT EXTEND BEYOND THE DURATION HEREOF. UNDER NO CIRCUMSTANCES WILL JACKSON WWS BE LIABLE FOR ANY LOSS OR DAMAGE, DIRECT OR CONSEQUENTIAL, OR FOR THE DAMAGES IN THE NATURE OF PENALTIES, ARISING OUT OF THE USE OR INABILITY TO USE ANY OF ITS PRODUCTS.

ITEMS NOT COVERED

THIS WARRANTY DOES NOT COVER CLEANING OR DELIMING OF THE UNIT OR ANY COMPONENT SUCH AS, BUT NOT LIMITED TO, WASH ARMS, RINSE ARMS OR STRAINERS AT ANYTIME. NOR DOES IT COVER ADJUSTMENTS SUCH AS, BUT NOT LIMITED TO TIMER CAMS, THERMOSTATS OR DOORS, BEYOND 30 DAYS FROM THE DATE OF INSTALLATION. IN ADDITION, THE WARRANTY WILL ONLY COVER REPLACEMENT WEAR ITEMS SUCH AS CURTAINS, DRAIN BALLS, DOOR GUIDES OR GASKETS DURING THE FIRST 30 DAYS AFTER INSTALLATION. ALSO, NOT COVERED ARE CONDITIONS CAUSED BY THE USE OF INCORRECT (NON-COMMERICAL) GRADE DETERGENTS, INCORRECT WATER TEMPERATURE OR PRESSURE, OR HARD WATER CONDITIONS.

REVISION HISTORY

Revision Letter	Revision Date	Made By	Applicable ECNs	Details
D	02-24-04	MAW	N/A	Added 10 U photo installation guide and all 10U Information.
E	02-11-14	MHH	QOF NBD	Updated manufacturer information and logos. Updated manufacturer warranty. Replaced figure 5 (pg. 7) that incorrectly showed 2 O-rings in use instead of 1. Replaced figure 8 (pg. 9) that showed internal vacuum breaker being installed backward.



10 SERIES

10A = 10 without a booster tank

10AB = 10 with a booster tank

10APRB = 10 with a booster tank and a power rinse pump

10U = 10 with a booster tank, a 4" shorter hood, and 9" shorter legs

Higher Hood Option = A hood that is 5" higher than the standard hood

Model: _____

Serial No.: _____

Installation Date: _____

Service Rep. Name: _____

Phone Number: _____

Jackson WWS, Inc. provides technical support for all of the dishmachines detailed in this manual. We strongly recommend that you refer to this manual before making a call to our technical support staff. Please have this manual with you when you call so that our staff can refer you, if necessary, to the proper page. Technical support is not available on holidays. Contact technical support toll free at 1-888-800-5672.

Technical support is available for service personnel only.

TABLE OF CONTENTS

SPECIFICATIONS	1
10A Dimensions.....	1
10AB/10APRB/10U Dimensions.....	2
Table Dimensions.....	3
Operating & Electrical Requirements	4
INSTALLATION/OPERATION INSTRUCTIONS.....	6
Visual Inspection/Unpacking the Dishmachine.....	6
Leveling the Dishmachine/Installing the Vacuum Breaker & Plumbing.....	7
Aligning the Machine/Installing the Internal Vacuum Breaker/Hood Assembly.....	8
Plumbing the Dishmachine/Drain Line Connection/Water Supply/Plumbing Check	9
Electrical Power Connection/ Voltage Check/ Final Check.....	10
Operation Instructions.....	11
Detergent Control	13
PREVENTATIVE MAINTENANCE	15
Preventative Maintenance	15
SERVICE PROCEDURES	16
Rinse Head/Wash Head Assemblies.....	16
Timer for 10 Series Dishmachines	19
Function of Switches, Circuit Breaker & Indicating Lights.....	21
Replacement of Switches in Control Panel	22
Thermostat Adjustment.....	23
Rinse Tank Heater System.....	24
Wash Tank Heater System.....	26
Water Level Control	28
Water Level Control (APRB).....	29
Replacing Seal & Ceramic on Wash and Rinse Pumps.....	30
TROUBLESHOOTING	31
Common Problems	32

PARTS35

10A Assembly 36

10AB/APRB Assembly..... 37

Control Box Assembly 39

Ordering Replacement Wire/Conduit Fittings 41

Ordering Replacement Conduit, Fittings & Hose 43

Tub Assembly 45

Bottom View Assembly 47

Wash Tank Cross View/Tub to Booster Connection 49

10AB/APRB Rinse Booster & Associated Parts 51

Pump & Motor Assembly 52

Thermostat Housing Assembly 53

Incoming Plumbing Assemblies..... 54

Solenoid Valve Repair Kit/Vacuum Breaker Repair Kit..... 55

Hood & Associated Assemblies..... 56

Vacuum Breaker/Connector Assemblies 10A Series 59

Vacuum Breaker/Connector Assemblies 10AB/10APRB/10U..... 60

Parts List for 10 Dishmachines..... 61

SCHEMATICS 64

10A, 10AB/10U, 10APRB 64

10A Wiring Diagram (208-230 VOLT, 60HZ, Single Phase)..... 65

10AB Wiring Diagram (208-230 VOLT, 60HZ, Single Phase)..... 66

10AB Wiring Diagram (208-230 VOLT, 60HZ, Three Phase) 67

10APRB Wiring Diagram (208-230 VOLT, 60HZ, Single Phase)..... 68

10APRB Wiring Diagram (208-230 VOLT, 60HZ, Three Phase) 69

SPECIFICATIONS

10A MACHINE DIMENSIONS

LEGEND

A - Water inlet 1/2" NPT. Plumbing can be directed either left or right.

B - Drain connection 1 1/2" NPT

C - Electrical connection

D - Clearance for dishes:

10" (10A 4" shorter hood)

14" (10A standard hood)

19" (10A 5" higher hood)

E - Machine height:

45 1/2" (9" shorter leg, 4" shorter hood)

58 1/4" (standard leg & hood)

63 1/4" (standard leg, 5" higher hood)

All dimensions in inches.

All vertical dimensions are +/- 1/2" from the floor due to the adjustable bullet feet.

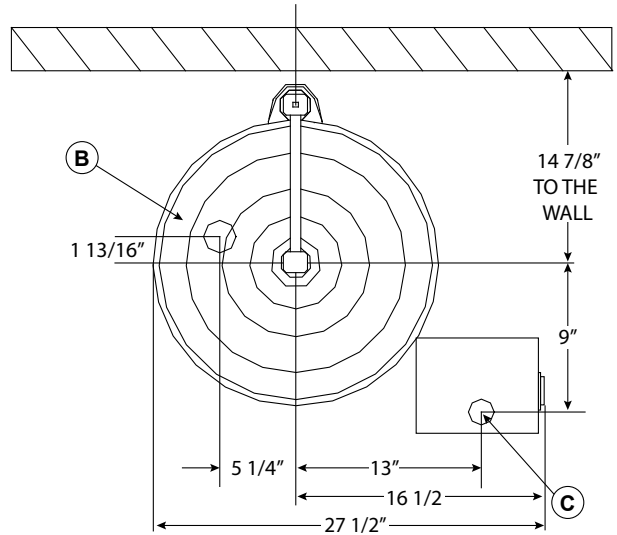

TOP VIEW

LEFT VIEW

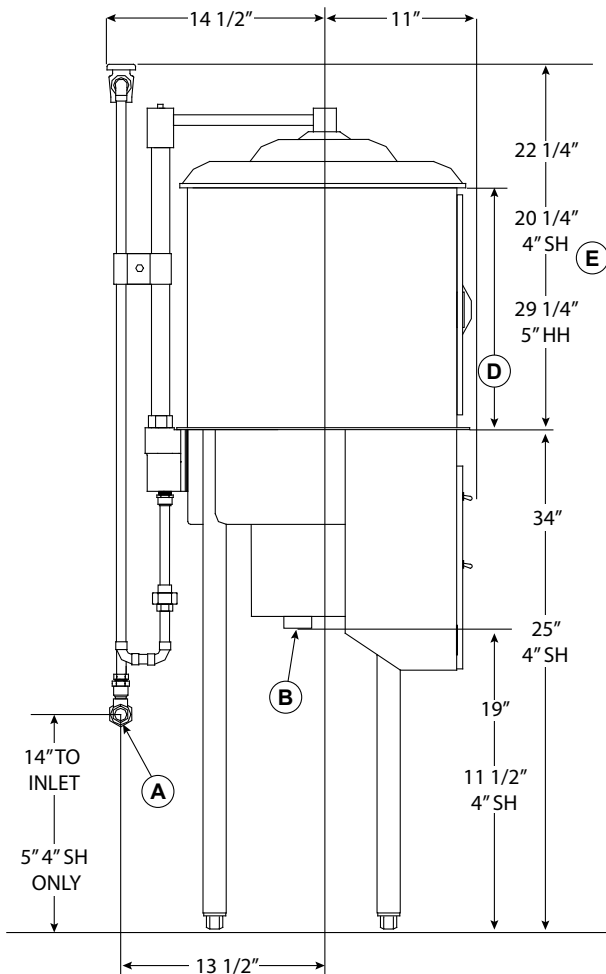

FRONT VIEW

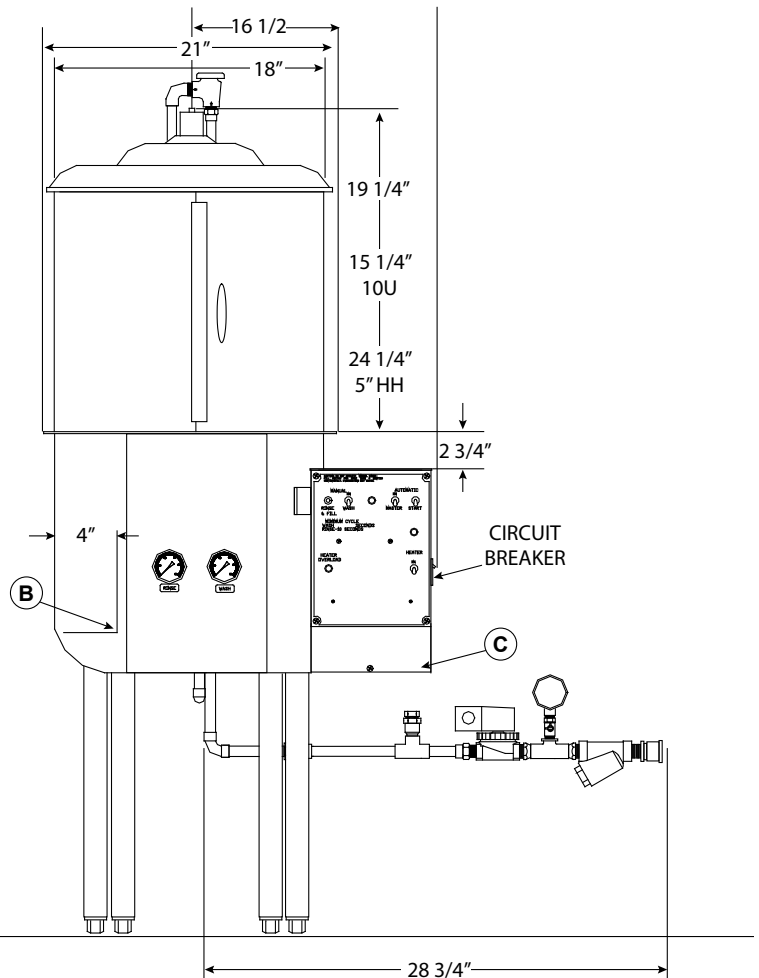

LEGEND

- A - Water inlet 1/2" NPT. Plumbing can be directed either left or right.
- B - Drain connection 1 1/2" NPT
- C - Electrical connection
- D - Clearance for dishes:
 - 10" (10U/10AB/10APRB 4" shorter hood)
 - 14" (10A/10AB/10APRB standard hood)
 - 19" (10A/10AB/10APRB 5" higher hood)
- E - Power rinse pump motor (10APRB only)
- F - Booster tank (10AB/10APRB/10U only)
- G - Machine height:
 - 45 1/2" (10U/10AB/10APRB, 9" shorter leg, 4" shorter hood)
 - 58 1/4" (10AB/10APRB standard leg & hood)
 - 63 1/4" (10AB/10APRB, standard leg, 5" higher hood)

All dimensions in inches.

All vertical dimensions are +/- 1/2" from the floor due to the adjustable bullet feet.

TOP VIEW

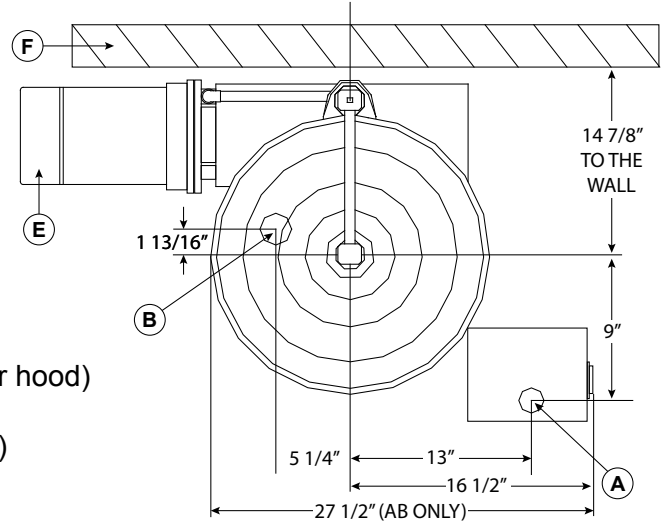

LEFT VIEW

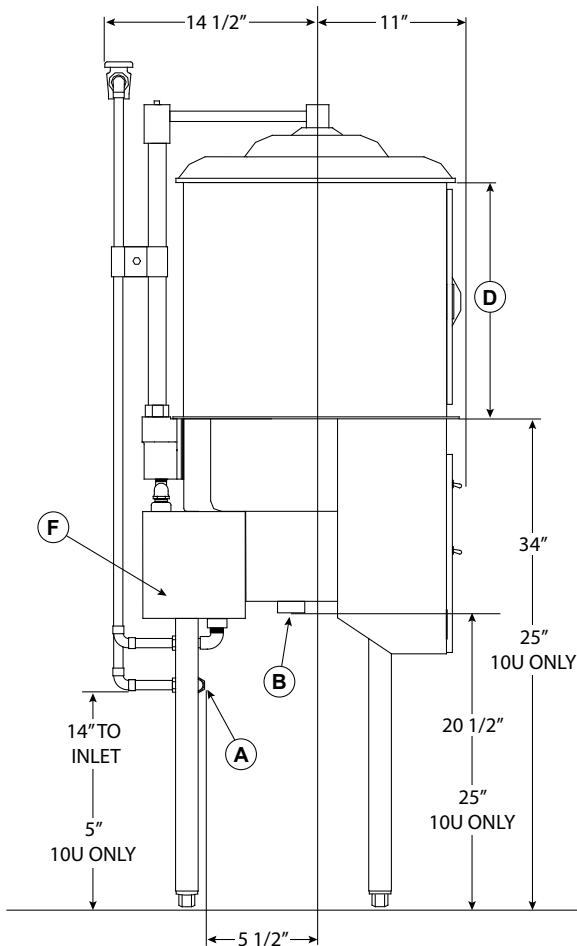

FRONT VIEW

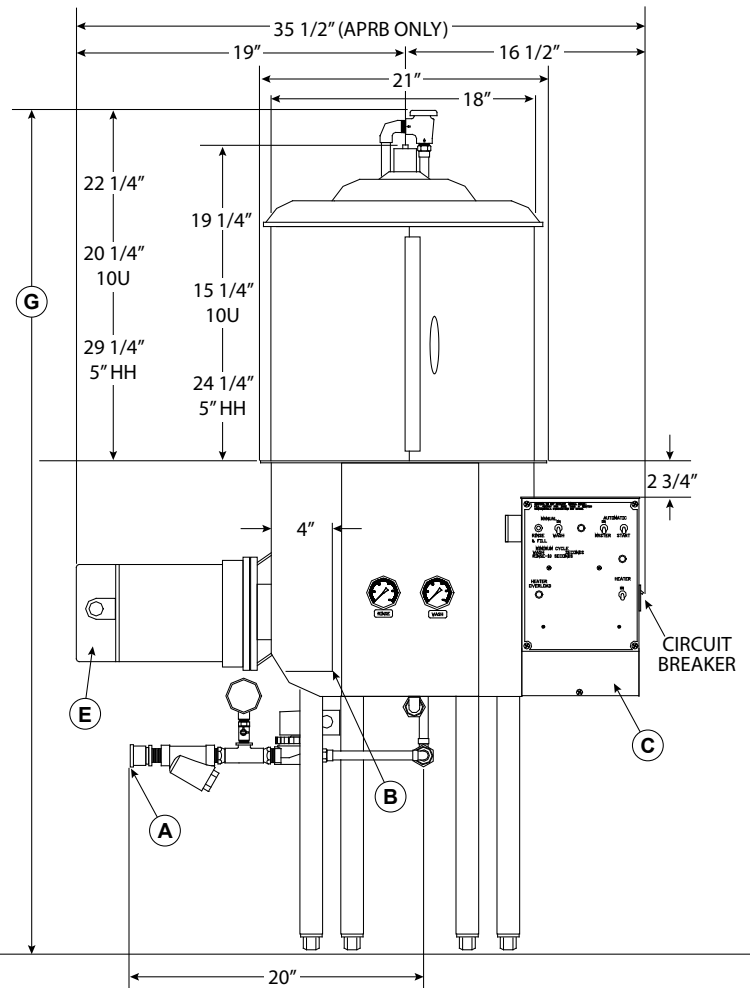

LEGEND

- A - 10" High backsplash, 2" turnback at 45B
- B - 3" High, 1 1/2" diameter rolled edge
- C - Scrap block
- D - Scrap basket with slide bars
- E - 20" x 20" x 5" deep pre-rinse sink
- F - Heavy duty pre-rinse
- G - 20" Slanted wall mounted overshelf 42" long
- H - 3 1/2" hole for sink drain with basket drain
- I - 1 7/8" hole for hood support piping

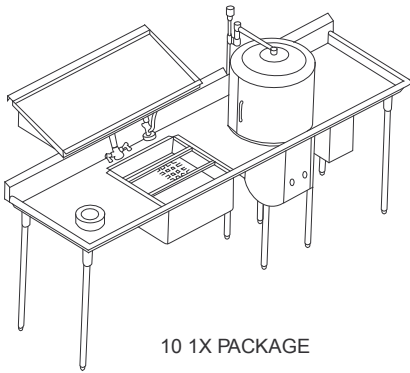

10 1X PACKAGE

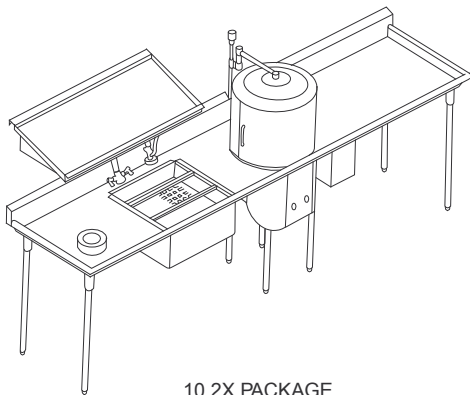

10 2X PACKAGE

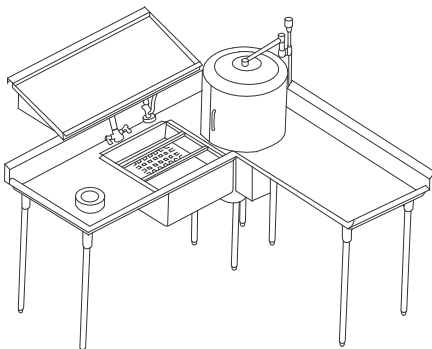

10 3X PACKAGE

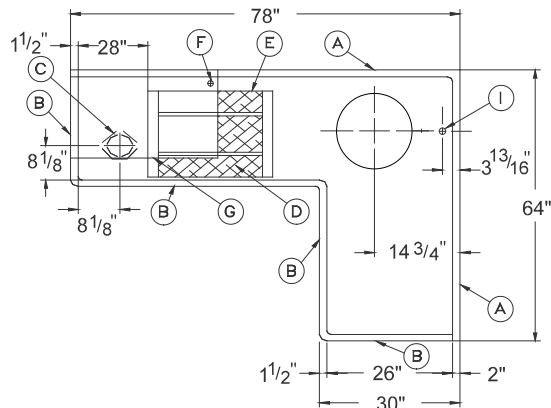
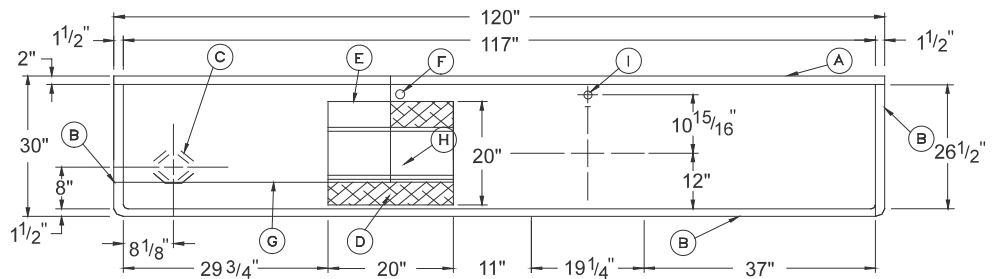
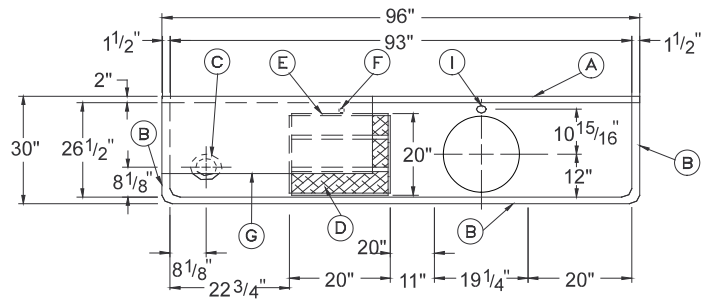

Model Designation: AVENGER HT-E

Operating Capacity:

Racks per Hour	45
Dishes per Hour	950
Glasses per Hour	950

Operating Cycle (Seconds):

Wash Time	60
Rinse Time	10
Total Cycle Time	72

Tank Capacity (Gallons):

Wash Tank	4.5
Booster Tank (10AB/10APRB/10U ONLY)	3.0

Pump Capacity (Gallons):

Wash Pump	70 GPM
-----------	--------

Electrical Loads (as applicable):

Wash Motor HP	1/2
Rinse Pump Motor HP (10APRB ONLY)	1/2

NOTE: Always refer to the machine data plate for specific electrical and water requirements. The material provided on this page is for reference only and is subject to change without notice.

HOT WATER SANITIZING

Water Temperatures (Fahrenheit):

Minimum Wash Temperature	150
Minimum Rinse Temperature	180

Water Requirements:

Inlet Temperature (10A)	108°F
Inlet Temperature (10AB/10ABPRB/10U)	140°F
Water Line Size NPT (Minimum)	1/2"
Drain Line Size I.D. (Minimum)	1 1/2"
Gallons Per Hour	58
Flow Pressure P.S.I. (Optimum)	25 ± 5
Flow Rate GPM	7.8

Racks

Dish (17 1/2" Diameter Round)	1
Glass and Silverware (17 1/2" Diameter Round)	1
Four Compartment Silverware	1

MODEL 10
Electrical Characteristics

Model	Volts	Phase	Hertz	Amps
10A	208	1	60	8.23
10A	220	1	60	8.23
10AB/10U	208	1	60	38.8
10AB/10U	208	3	60	25.6
10AB/10U	220	1	60	37.2
10AB/10U	220	3	60	24.6
10APRB	208	1	60	43.4
10APRB	208	3	60	30.2
10APRB	220	1	60	41.8
10APRB	220	3	60	29.2

NOTE 1: MCA (Minimum Circuit Ampacity) = 125% x Largest Motor +FLA of all other motors + all other loads.

NOTE 2: MOP (Maximum Overcurrent Protective Device) = 225% x Largest Motor + FLA of all other motors + all other loads.

All electrical ratings provided in this manual are for reference only. Always refer to the machine data plate to get exact electrical information for this machine. All electrical work performed on machines should be done in accordance with applicable local, state, territorial and national codes. Work should only be performed by qualified electricians and authorized service agents.

Where applicable, heating element amperage draws have been adjusted for the assumed input voltage. Jackson assumes incoming voltages will be either 208 or 230 volts. Some heating elements used in the machines are rated for other voltages, such as 240 volts. Always verify the amperage draw of the machine in operation when sizing circuit protection.

If the dishmachine is equipped with the optional rinse heater, note the rinse heater may have its own electrical connection and therefore require a separate service. Amperage loads for motors and heaters are indicated on the machine data plate.

The electrical configurations of the AVENGER series of machines are as follows:

Available Electrical Characteristics:

- 10A 208 - 220 V, 60 HZ, single phase
- 10AB 208 - 220 V, 60 HZ, single phase
- 10AB/10U 208 - 220 V, 60 HZ, three phase
- 10AB/APRB/10U 208 - 220 V, 60 HZ, single phase
- 10AB/APRB/10U 208 - 220 V, 60 HZ, three phase

Jackson WWS Inc. provides technical support for all of the dishmachines detailed in this manual and recommends that service personnel have this manual on hand when calling technical support staff. Technical support is available from 8:00 a.m. to 5:00 p.m. (EST), Monday through Friday. Technical support is not available on holidays. Contact technical support toll free at 1-888-800-5672. Please remember that technical support is available for service personnel only.

VISUAL INSPECTION

**DO NOT THROW AWAY
CONTAINER IF DAMAGE
IS EVIDENT**

Before installing unit check container and machine for damage. A damaged container may be an indication of damage to the machine. If there is any type of damage to both container and unit, do not throw away the container. The dishmachine has been inspected at the factory prior to shipping and is expected to arrive in new, undamaged condition. However, rough handling by carriers or others may result in damage to the unit while it is in transit. If such a situation occurs, do not return the unit to the manufacturer. Instead, contact the carrier and ask them to send a representative to the site to inspect the damage, and request that an inspection report be completed.

Contact the carrier within 48 hours of receiving the machine (to report possible freight damage) and the dealer from whom the unit was purchased.

UNPACKING THE MACHINE

Note: Be careful when cutting the hold down strap (Fig. 1), it is under tension. Remove the hood (Fig. 2) and set to the side. Please note (Fig. 3) for the location of the O-ring. Once the machine has been removed from the container, ensure that there are no missing parts (Fig. 3 & 4) from the machine. This may not be obvious at first. If it is discovered that an item is missing, contact Jackson immediately to have the missing item shipped to you.



(Fig. 1)



(Fig. 2)



(Fig. 3)



(Fig. 4)

LEVEL THE DISHMACHINE

The dishmachine is designed to operate while being level. This is important to prevent any damage to the machine during operation and to ensure the best results when washing ware. The unit comes with adjustable bullet feet (Fig. 5), which can be turned using a pair of channel locks or by hand if the unit can be raised safely. Ensure that the top of the tub is level from side to side and from front to back before making any connections.



(Fig. 5)

INSTALLING THE DISHMACHINE

With the machine base set in place, lift the table (Fig. 6) (with proper flange cutout) over and above machine so that vertical flange on table cutout fits down inside of machine tub and horizontal flange on machine tub fits up tight against underside of the table.



(Fig. 6)

INSTALLING THE VACUUM BREAKER & PLUMBING:

Ease vacuum breaker piping (Fig. 7) supplied with the dishmachine down through the square cutout in the backsplash of the table (directly behind the machine). Connect vacuum breaker piping to machine. The top union connects to its matching half on the bottom of the rinse booster tank (Fig.8). The bottom union of the piping connects to an adapter pipe which, in turn connects to the solenoid valve (Fig. 9). The arrows on the solenoid valve indicate the direction of water flow to the machine. Tighten both of the connections.



(Fig. 7)



(Fig. 8)



(Fig. 9)

ALIGNING THE MACHINE: Adjust the machine base to line up hole in table with hole in support block (Fig. 10).



(Fig. 10)

INSTALLING THE INTERNAL VACUUM BREAKER: Insert internal vacuum breaker pipe into hood support block pin end down (Fig.11).



WARNING: Internal vacuum breaker pipe must be installed or there will be a hazard to the operator.



(Fig. 11)

INSTALLING THE HOOD ASSEMBLY: Make sure there are two “O-rings” (Fig. 5) on the lower support pipe near the end of the ring. While also holding the internal vacuum breaker, lift the hood and hood support pipe up over table. Set hood support pipe down into the support block hole (Fig. 12) and begin to work the hex nut into the hole. The locating pin in the support block will insure proper line up. While holding the support pipe, start tightening nut by hand to prevent cross threading. It should tighten considerable by hand. Then continue tightening with a wrench. It may be necessary to work support pipe back and forth to seat nut properly. When the nut is tight, it should force flat the stainless steel and rubber washers tight to the table top.



(Fig. 12)

Attach vacuum breaker support pipe clamp (Fig. 13) to the support pipe and external vacuum breaker piping. Slide up about 12” from the table and tighten securely. Position cover plate (supplied with table) over square cutout in backsplash on table so that it fits tightly around piping then snap in the four nylon fasteners (supplied) to hold in place.



(Fig. 13)

Rotate the hood to insure it is free, if not, check level of machine, tightness of table to machine flange, centering of machine, level of table and hood support pipe.

PLUMBING THE DISHMACHINE:

All plumbing connections must comply with all applicable local, state, and national plumbing codes. The plumber is responsible for ensuring that the incoming water line is thoroughly flushed prior to connecting it to any component of the dishmachine. It is necessary to remove all foreign debris from the water line that may potentially get trapped in the valves or cause an obstruction. Any valves that are fouled as a result of foreign matter left in the water line, and any expenses resulting from this fouling, are not the responsibility of the manufacturer.

CONNECTING THE DRAIN LINE:

The drain for the dishmachine is a gravity discharge drain. Remove the overflow strainer stopper from the tub and the unit will drain itself. There must also be an air gap between the machine drain line and the floor sink or drain. If a grease trap is required by code, it should have a flow capacity of 5 gallons per minute.

WATER SUPPLY CONNECTION:

Ensure that you have read the section entitled "PLUMBING THE DISHMACHINE" above before proceeding. Install the water supply line (3/4" pipe size minimum) to the end of the Y-strainer. It is recommended that a water shut-off valve be installed in the water line between the main supply and the machine to allow access for service. The water supply line is to be capable of 25 PSI "flow" pressure at the recommended temperature indicated on the data plate. In areas where the water pressure fluctuates or is greater than the recommended pressure, it is suggested that a water pressure regulator be installed. The Model 10 does not come with water a pressure regulator as standard equipment.

Take care not to confuse static pressure with flow pressure.

Do not confuse static pressure with flow pressure. Static pressure is the line pressure in a "no flow" condition (all valves and services are closed). Flow pressure is the pressure in the fill line when the fill valve is opened during the cycle.

It is also recommended that a shock absorber (not supplied with the dishmachine) be installed in the incoming water line. This prevents line hammer (hydraulic shock), induced by the solenoid valve as it operates, from causing damage to the equipment.

PLUMBING CHECK:

Slowly turn on the water supply to the machine after the incoming fill line and the drain line have been installed. Check for any leaks and repair as required. All leaks must be repaired prior to placing the machine in operation.

ELECTRICAL POWER CONNECTION: Electrical and grounding connections must comply with the applicable portions of the National Electrical Code ANSI/NFPA 70 (latest edition) and/or other electrical codes.

Disconnect electrical power supply and place a tag at the disconnect switch to indicate that you are working on the circuit.

Refer to the data plate for machine operating requirements, machine voltage, total amperage load and serial number.

To install the incoming power lines, first remove the lower control box cover (Fig. 14). Next, run the power lines through the hole located in the bottom of the control box to the terminal board inside (Fig. 15). This board is accessible by removing the lower cover plate on the control box. Attach lines (L1 and L2 (L3 for three phase)) on the terminal block at the lower front right corner. There is no neutral wire on this machine. There is a grounding lug inside the control box on the bottom left. Be sure all connections made are tightened properly. It is recommended that "DE-OX" or another similar anti-oxidation agent be used on all power connections.

VOLTAGE CHECK: Ensure that the power switch is in the OFF position and apply power to the dishmachine. Check the incoming power at the terminal block and ensure it corresponds to the voltage listed on the data plate. If not, contact a qualified service agency to examine the problem. Do not run the dishmachine if the voltage is too high or too low. Shut off the service breaker and mark it as being for the dishmachine. Advise all proper personnel of any problems and of the location of the service breaker. Replace the lower cover and tighten down the screws.



(Fig. 14)



(Fig. 15)

FINAL CHECK: Check all fittings and connections before and after first 10 cycles. Deliver Installation/ Operation Manual to site manager. Contact Jackson for free performance and installation check.

- PREPARATION:**
1. Ensure that the pump intake strainer (1) and basket overflow strainer (2) are inserted and tight.
 2. Ensure that the wash and rinse arms are installed and secure.
 3. Remove all solid wastes in order to avoid obstructing filters, drain and wash and rinse arms.
 4. Ware that is encrusted with soil should be presoaked prior to being placed in the machine.
 5. When placing dishes into the racks, do not allow them to lean on each other.

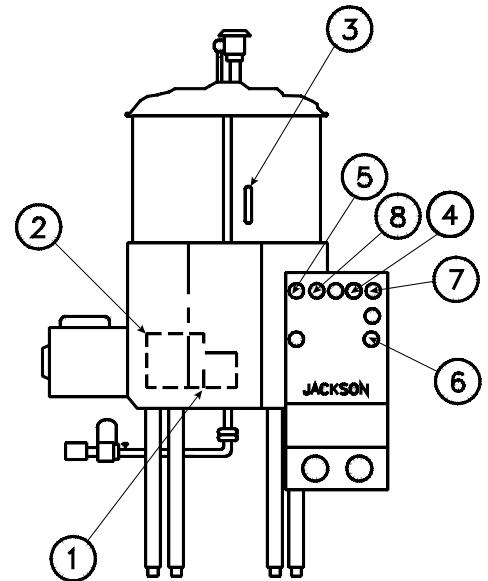

6. Place the glasses upside down in the open rack. With the model 10 series, a four compartment silverware rack is supplied. Place silver in compartment rack loosely not allowing it to mix with other silverware of the same nature. Place the compartment rack in the open rack and wash with the cups and glasses.

DAILY MACHINE PREPARATION:

Refer to the section entitled "PREPARATION" at the top of this page and follow the instructions there. Afterwards, check that all of the chemical levels are correct and/or that there is plenty of detergent available for the expected workload.

WARM-UP CYCLE:

At the beginning of each work day, a warm up cycle will need to be performed. Close the hood (3). Turn on the master switch (4). Raise the fill switch (5) until the machine is filled to the top of the basket overflow strainer (2.) Once the proper water level has been reached, turn on the heater switch (6). Observe the temperature gauges, the rinse temperature should rise to a specified level of 180°F within five minutes if the incoming water to the booster tank is 140°F. The wash heater will take longer to reach 150°F as the element is designed for maintaining temperature, not heating. Once the proper temperature has been reached, with the hood closed, turn on the manual wash switch. You should hear the water being pumped as it strikes the top of the hood. Turn off the manual wash switch. The dishmachine is now ready to proceed with washing of the dishes.

WARE PREPARATION: Proper preparation of ware will help ensure good results and less re-washes. If not done properly, ware may not come out clean and the efficiency of the dishmachine will be reduced. It is important to remember that a dishmachine is not a garbage disposal and that throwing unscrapped dishes into the machine will defeat the purpose altogether of washing the ware. Scraps should be removed from ware prior to being loaded into a rack. Pre-rinsing and pre-soaking are good ideas, especially for silverware and casserole dishes. Place cups and glasses upside down in racks so that they do not hold water during the cycle. The dishmachine is meant not only to clean, but to sanitize as well, to destroy all of the bacteria that could be harmful to human beings. In order to do this, ware must be properly prepared prior to being placed in the machine.

WASHING A RACK OF WARE: To wash a rack, open the hood completely (being careful for hot water that may drip from the top of the hood), manually load detergent into the wash chamber, or if automatic detergent dispenser is used, follow the manufacturers instructions. Slide the rack of dishes into the dishmachine. Close the hood. Start the automatic wash and rinse cycle of the dishmachine by flipping the start switch (7) either up or down (NOTE: The start switch, is a three position switch. Up = Start, Center = Off, Down = Start) the indicating light (8) will come on at the start of the cycle. When the light goes off, the cycle is complete. Open the hood, remove the rack of clean dishes to air dry. Repeat the cycle by adding another rack of soiled dishes, adding the detergent, close hood and flip start switch (8) in opposite direction.

SHUT DOWN AND CLEANING At the end of meal time, shut off the dishmachine by placing the start switch in center position and turn heat switch off. Drain the dishmachine by removing the overflow strainer. Remove the pump intake strainer after water has drained. Clean both strainers. Clean the inside of the unit. Clean wash head, upper and lower rinse arms and replace the clean strainers. Replace all removed parts. The machine is now ready for refilling and operation.

DETERGENT CONTROL: Detergent usage and water hardness are two factors that contribute greatly to how efficiently your dishmachine will operate. Using detergent in the proper amount can become, in time, a source of substantial savings. A qualified water treatment specialist can tell you what is needed for maximum efficiency from your detergent, but you should still know some basics so you'll understand what they are talking about.

First, you must understand that hard water greatly effects the performance of the dishmachine. Water hardness is the amount of dissolved calcium and magnesium in the water supply. The more dissolved solids in the water, the greater the water hardness. Hard water works against detergent, thereby causing the amount of detergent required for washing to increase. As you use more detergent, your costs for operating the dishmachine will increase and the results will decrease. The solids in hard water also may build-up as a scale on wash and rinse heaters, decreasing their ability to heat water. Water temperature is important in removing soil and sanitizing dishes. If the water cannot get hot enough, your results may not be satisfactory. This is why Jackson recommends that if you have installed the machine in an area with hard water, that you also install some type of water treatment equipment to help remove the dissolved solids from the water before it gets to the dishmachine.

Second, hard water may have you adding drying agents to your operating cycle to prevent spotting, when the real problem is deposited solids on your ware. As the water evaporates off of the ware, the solids will be left behind to form the spotting and no amount of drying agent will prevent this. Again, using treated water will undoubtedly reduce the occurrences of this problem.

Third, treated water may not be suitable for use in other areas of your operation. For instance, coffee made with soft water may have an acid or bitter flavor. It may only be feasible to install a small treatment unit for the water going into the dishmachine itself. Discuss this option with your qualified water treatment specialist.

Even after the water hardness problems have been solved, there still must be proper training of dishmachine operators in how much detergent is to be used per cycle. Talk with your water treatment specialist and detergent vendor and come up with a complete training program for operators. Using too much detergent has as detrimental effects as using too little. The proper amount of detergent must be used for job. It is important to remember that certain menu items may require extra detergent by their nature and personnel need to be made aware of this. Experience in using the dishmachine under a variety of conditions, along with good training in the operation of the machine, can go a long way in ensuring your dishmachine operates as efficiently as possible.

Certain dishmachine models require that chemicals be provided for proper operation and sanitization. Some models even require the installation of third-party chemical feeders to introduce those chemicals to the machine. Jackson does not recommend

DETERGENT CONTROL (CONTINUED): or endorse any brand name of chemicals or chemical dispensing equipment. Contact your local chemical distributor for questions concerning these subjects.

Some dishmachines come equipped with integral solid detergent dispensers. These dispensers are designed to accommodate detergents in a certain sized container. If you have such a unit, remember to explain this to your chemical distributor upon first contacting them.

As explained before, water temperature is an important factor in ensuring that your dishmachine functions properly. The data plate located on each unit details what the minimum temperatures must be for either the incoming water supply, the wash tank and the rinse tank, depending on what model of dishmachine you have installed. These temperatures may also be followed by temperatures that Jackson recommends to ensure the highest performance from your dishmachine. However, if the minimum requirements are not met, the chances are your dishes will not be clean or sanitized. Remember, a dish can look clean, but it may not be sanitized. Instruct your dishmachine operators to observe the required temperatures and to report when they fall below the minimum allowed. A loss of temperature can indicate a much larger problem such as a failed heater or it could also indicate that the hot water heater for your operation is not up to capacity and a larger one may need to be installed.

There are several factors to consider when installing your dishmachine to ensure that you get the best possible results from it and that it operates at peak efficiency for many years. Discuss your concerns with your local chemical distributor and water treatment specialist before there is a problem.

**PREVENTATIVE
MAINTENANCE**

Proper maintenance of your Jackson dishmachine will insure optimum service with a minimum of down time.

1. To delime the booster tank.
 - a. Remove the support pipe nut and lift the whole hood assembly away from the unit.
 - b. Loosen the fitting going into bottom side of booster tank.
 - c. Drain approximately 2 to 3 cups out of the tank.
 - d. Pour 1 to 2 cups of delimer into the hood support block opening, after tightening the booster tank union.
 - e. Replace the hood assembly.
 - f. Turn on the heat switch for 30 minutes.
 - g. Fill the machine with water.
 - h. Turn on manual wash switch and allow the unit to run for about 20 minutes.
 - i. Empty the machine and refill at least twice.
2. To remove all lime and corrosion deposits.
 - a. Fill the machine with wash water as would ordinarily be done for washing.
 - b. Open the door and place one cup or less of deliming compound into the water. (Be sure to follow their directions if they vary from these being given) which is available from your detergent supplier. Read and follow the label instructions.
 - c. Turn on the manual wash switch and allow to wash for five minutes.
 - d. Open the door and examine the interior. All lime should be removed and parts should be shiny. If not, allow to wash for a longer period.
 - e. After the interior is clean, empty the wash water by removing overflow strainer.
 - f. Replace the overflow strainer. Refill machine and allow to run for two minutes, then again drain the wash reservoir.
 - g. Refill as it is ready for regular operation.
3. Clean strainers.
 - a. Clean around overflow and pump intake strainer holes.
 - b. Clean around pump intake (a toothbrush makes a good cleaning tool).
4. Clean Y-strainer on the incoming water line. (Water to the machine must be turned off for this operation.)
 - a. Remove the plug and clean the strainer.
5. Clean rinse tubes.
 - a. Remove the end plugs on the lower and upper rinse arms.
 - b. Clean all rinse tubes with the special brush provided.
 - c. If spray holes in the rinse tubes are clogged, they may be cleaned with a pointed tool.
6. Clean the wash head assembly.
 - a. If the spray jets are plugged, use a pointed tool to dislodge and flush with water.
 - b. If lodged items still remain in the wash tubes, remove the wash assembly by first removing the rinse assembly.
 - c. Clean the assembly at the sink by flushing water through the spray jets.
 - d. Reinstall the wash and rinse assemblies.
7. Clean any deposits which may have built up on exterior moving parts.

RINSE/WASH HEAD ASSEMBLIES:

1. Turn master switch to off position.
2. Open hood and drain machine by lifting overflow strainer.
3. When empty, replace overflow strainer.
4. Remove the pin holding the rinse feed pipe and remove the feed pipe and rinse head assembly.
5. Locate the allen head set screw in the wash head cap and loosen screw by turning counter-clockwise.
6. Turn the wash head cap counter-clockwise until the cap is removed and put the cap in a secure area.
7. Carefully remove the 1/4" stainless steel ball bearings and place in a container. Take special care to prevent any from falling through the wash tub base for these will fall into the motor impeller. If any should fall into this area, the motor will have to be removed to retrieve the ball bearings. If any should drop in the machine, you will be able to locate and retrieve these if you left the overflow strainer in as suggested in step 3.
8. Lift and remove the small manifold with the short tubes and place in a secure area.
9. Carefully remove the 1/4" stainless steel ball bearings and place in a container.
10. Lift and remove the large manifold with the long tubes and place in a secure area.
11. The lower fixed race may be left in place. 21. Replace the rinse feed pipe and rinse head assembly. Replace the pin through the rinse feed casting and rinse feed pipe.
12. Clean the ball bearings by soaking in a deliming solution.
13. The ball bearing raceways may be cleaned by either brushing with deliming solution or gently cleaned by rubbing with fine sandpaper or emery cloth.
14. Rinse the ball bearings and manifolds thoroughly.
15. To reassemble, first fill the lower raceway to capacity with the 1/4" ball bearings, then remove one. This will allow proper movement needed during rotation of assembly.

**RINSE/WASH
HEAD ASSEMBLIES
(CONTUNIED):**

16. Replace the lower large manifold and fill the raceway fully with the bearings, then remove one.
17. Replace the upper small manifold and fill raceway fully with bearings, then remove one.
18. Replace the wash cap by turning clockwise onto the center shaft and finger-tighten.
19. Turn the wash cap counter-clockwise by a 1/4" turn and tighten the allen set screw.
20. Rotate the manifolds in opposite directions and see if they rotate freely. (Select the longest tube in the bottom manifold and make sure it moves up and down at least 1/8" and no more than 1/4".)
22. Close the hood doors and refill the dishwasher.
23. Run through several cycles and recheck the wash manifolds for easy movement. Adjust if necessary.

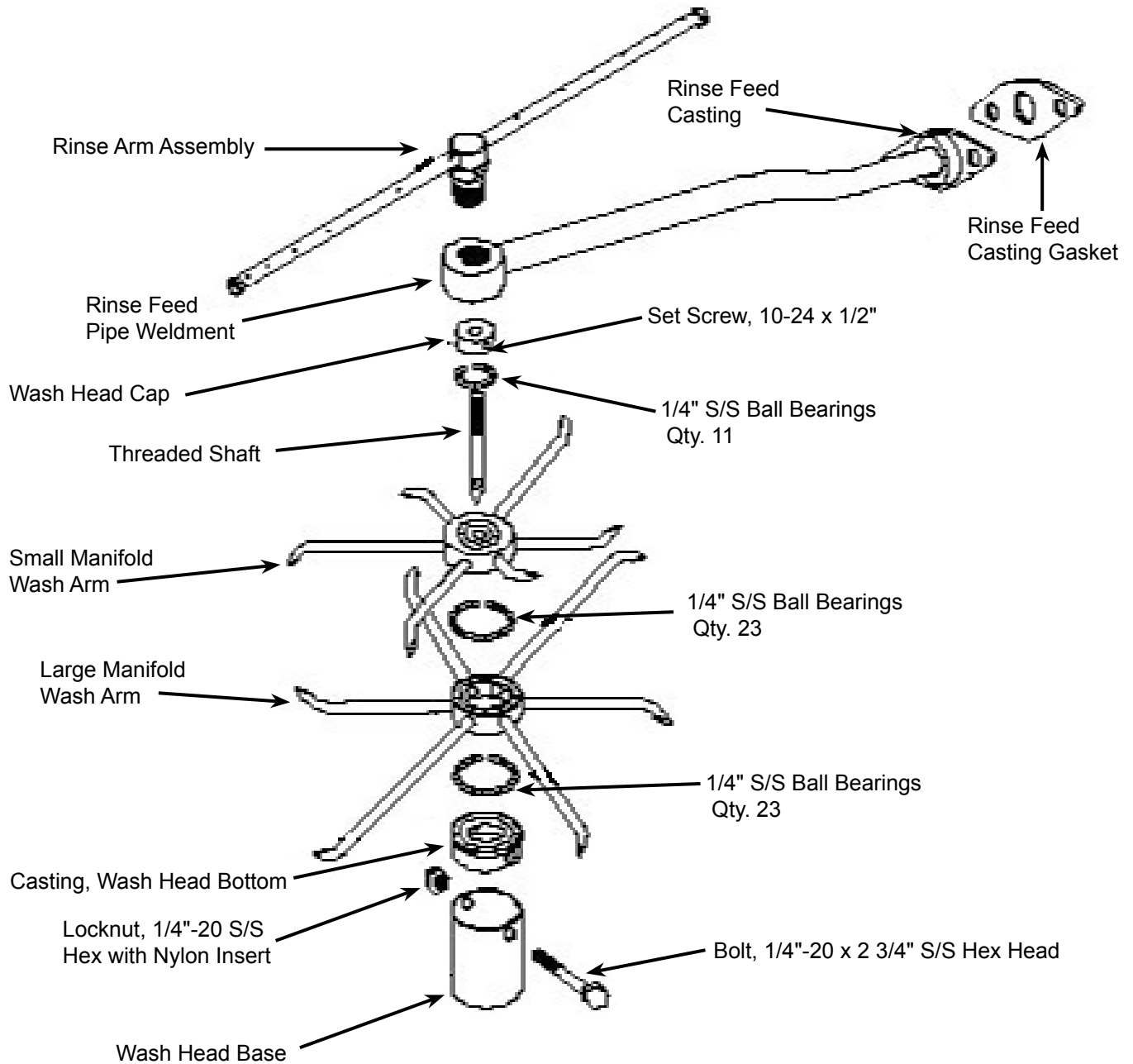

GENERAL DESCRIPTION: GENERAL DESCRIPTION: The timer is a self-contained (frame mounted) timer of the repeating cycle type. It is mounted on the control panel of the control box to control the automatic functions of the machine. It consists of a clock motor which operates on 60 cycle AC, 220 VAC. In addition to the clock motor, the timer contains a driven cam arrangement which operates three microswitches.

PRINCIPLE OF OPERATION: The timer controls various operations of the dishmachine as per the wiring diagrams for each machine, however, the timing cycle and the microswitches are the same for each model. The time for one complete revolution of the cam shaft is approximately 150 seconds, allowing two wash and two rinse operations for each complete revolution of the cam shaft. The microswitch nearest the timer motor is the hold circuit and uses both the NO and NC contacts. The middle microswitch controls the wash and uses the NO contact. The switch farthest away from the timer motor controls the rinse and uses just the NC contact.

SERVICE INSTRUCTIONS: Timer operation can be observed after removing the control panel from the control box by loosening the four screws holding it. Hang the control panel using the two right-hand screws with the back side of the panel outward.

CAUTION:
ALWAYS REMOVE THE POWER TO THE MACHINE BEFORE WORKING ON THE CONTROL PANEL OR WHILE SERVICING THE COMPONENTS ON THE SWITCH PANEL. ALL ELECTRICAL CHECKS SHOULD BE MADE BY QUALIFIED PERSONNEL.

If it is determined that the timer is defective, it is recommended that a new timer be installed. However, limited field maintenance can be accomplished as follows: A frozen contact on a microswitch will be indicated by one function being executed all the time or the absence of a click when the switch arm is actuated. To replace microswitch:

1. Remove all wires from the timer, properly tag them to assure proper replacement.
2. Remove the two screws which hold the timer to the control panel.
3. One screw holds the microswitches, cams and actuating arms in the frame. The screw is seen on the side opposite the motor. Remove this screw.

NOTE: Be sure to note which cam goes with which microswitch. Cam nearest timer motor has 1/2 raised, cam center, larger depressed areas, cam farthest from timer motor, smallest depressed areas.

4. The unit can now be taken apart and the defective microswitch replaced.
5. Reassemble. NOTE: The flanges on the cams are such that they only mesh in one direction. The shorter flange on the cams always points toward the drive motor.

The timer's cam drive system is equipped with a clutch to enable user to view the operations of the cams and microswitches. Remove power to the machine BEFORE touching the timer. Rotate the cams by turning with fingers; cam will turn in one direction only. Do not force them. As cams actuate switches, listen for the click of the switch or test the switches with an ohm-meter.

SERVICE INSTRUCTIONS:

A defective motor is indicated by the fact that the cams do not rotate or the machine does not perform the automatic operations or performs a specific part of the cycle continuously, but works okay on manual. Remember, the timer motor is controlled by the start switch and the hold microswitch, check this complete circuit before changing the motor. NOTE: It may be necessary to remove complete timer to replace motor; if so, follow steps 1 and 2 for removing the microswitches.

To replace the motor:

1. Remove motor leads from connection points.
2. Remove the two screws which hold the motor.
3. Replace with the new motor.
4. Re-connect motor leads to proper points.

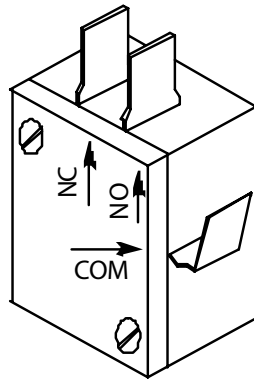

Timer Switch
Mfg. No.: 5945-306-02-00

- A. To upper right terminal start switch
- B. To lower right terminal start switch
- C. To right-central terminal manual wash switch
- D. To upper terminal of rinse switch
- E. To #5 terminal
- F. Shorting bar or jumpers connected to all three timer switches, this terminal

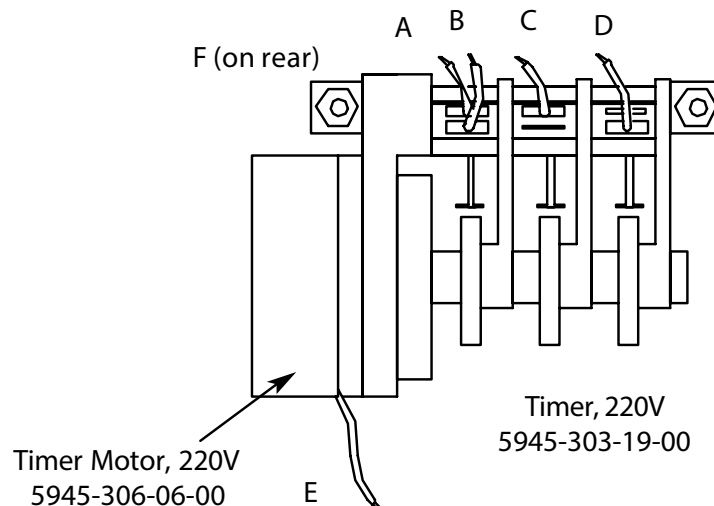

**FUNCTION OF SWITCHES, CIRCUIT BREAKER & INDICATING
LIGHTS/REPLACEMENT OF SWITCHES**

CIRCUIT BREAKER: Rated 15 amps, controls power to the control circuit only, i.e. timer, relays, solenoid valve, water level control and motors. The circuit breaker does not cut off power in the control box at incoming terminal board and rinse heater relay contacts. Power is still applied to them when the circuit breaker is in "off" position.

MASTER SWITCH: The switch interrupts all power going to the control circuit, this means that all switches on control panel are inoperable until master switch is turned "on."

START SWITCH: This switch controls the timer motor through two circuits (see electrical diagram) it is a three-position switch, up position = start, middle position = off, down position = start. To start, flip switch toggle in either up or down position; indicating light in center of panel will light verifying automatic cycle has started. After cycle ends and you are ready to start a new cycle, flip toggle to opposite position.

CYCLE LIGHT: This light comes on only when automatic cycle is in progress and extinguishes when cycle is complete.

MANUAL WASH SWITCH: This switch is used to bypass the timer and operate the wash pump manually. The wash pump will run as long as this switch is "on." The prime purpose of this switch is to extend the wash period for extremely soiled dishes before putting them through the normal automatic cycle. It may also be used as an emergency backup in case of timer failure for rinsing dishes. The required rinse time is indicated on the front control panel.

RINSE/FILL SWITCH: This switch is spring-loaded and must be held in its up position to operate. When the switch is operated, water is allowed to fill machine through the rinse heads. It may be used as an emergency backup in case of timer failure for rinsing dishes. The required rinse time is indicated on the front control panel.

HEAT SWITCH: This switch applies power to the heat circuits which are composed of automatic control devices that turn heaters on and off to maintain required temperatures.

REPLACEMENT OF SWITCHES IN CONTROL PANEL

HEAT LIGHT: This indicating light remains lit all the time the heat switch is on.

There are five switches installed in the control box cover panel. These are the start, master, manual wash, rinse-fill and heater switches.

Before working on the machine, it is important that power be turned off at the customer's circuit breaker to prevent the possibility of electrical shock, trip breaker to "off" position.

Remove control panel from the control box by removing the four screws holding it in place. Hang the control panel using the two right-hand upper and lower screw receptacles on the control box with backside of panel facing outward. The five switches are mounted in individual round holes with a keyway. By using a pair of pliers, or open-end wrench, it is possible to loosen the inside nut enough to allow the outside nut holding the switch to be removed by fingers. Push switch out of hole.

If a switch is found to be defective, replacement can be achieved by placing the new switch next to the old one. To make the new switch is not upside down, line up with the keyways. Transfer wires one at a time to the new switch. If this is not practical, pull wires off, one at a time and tag them for proper replacement.

Put switches back into panel, make sure switch protrudes through panel properly, tighten both nuts, and replace control panel on control box. Power can now be applied to the dishmachine and run through cycles checking all operations.

1. Connection terminals
2. Inside nut
3. Panel plate
4. Outside nut
5. Bar or toggle handle

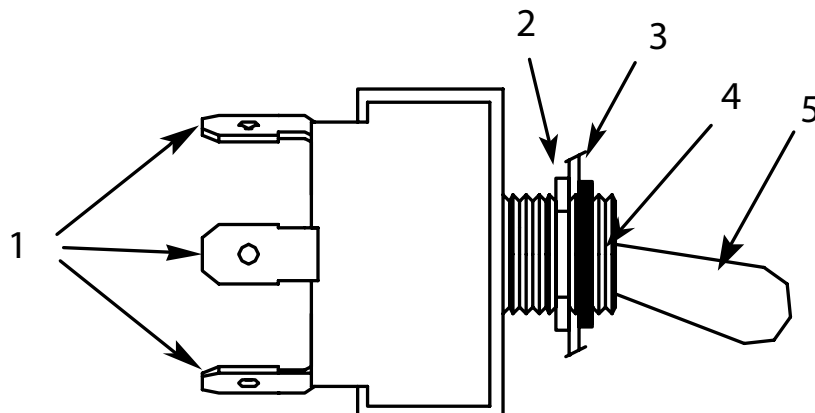

THERMOSTAT ADJUSTMENT:

The thermostat can be adjusted by turning screw #1 (see diagram below) on the thermostat housing cover. (Remember the preset setting in case the problems are elsewhere in the control circuit.) A clockwise rotation is used to obtain a lower temperature setting and a counter-clockwise rotation is used to obtain a higher temperature setting. A 1/8" turn of screw #1 changes the temperature approximately 15°F. If screw #1 is turned all the way to its stop in either direction; adjust screw #2 as follows. **DO NOT TOUCH THE SCREW SEALED WITH RED PAINT!** When adjusting screw #2, power should be disconnected during adjustment.

Set screw #1 so that it can be turned equal distances in either direction, then:

-if screw #1 stopped while turning in clockwise direction, turn screw #2 3/4" turn in a clockwise direction.

-if screw #1 stopped while turning in counterclockwise direction, turn screw #2 3/4" turn in a counterclockwise direction.

This will bring the thermostat to approximately the same setting obtained where screw #1 stopped. Check the preset temperature setting before attempting any further adjustments. Use screw #1 for any further adjustments.

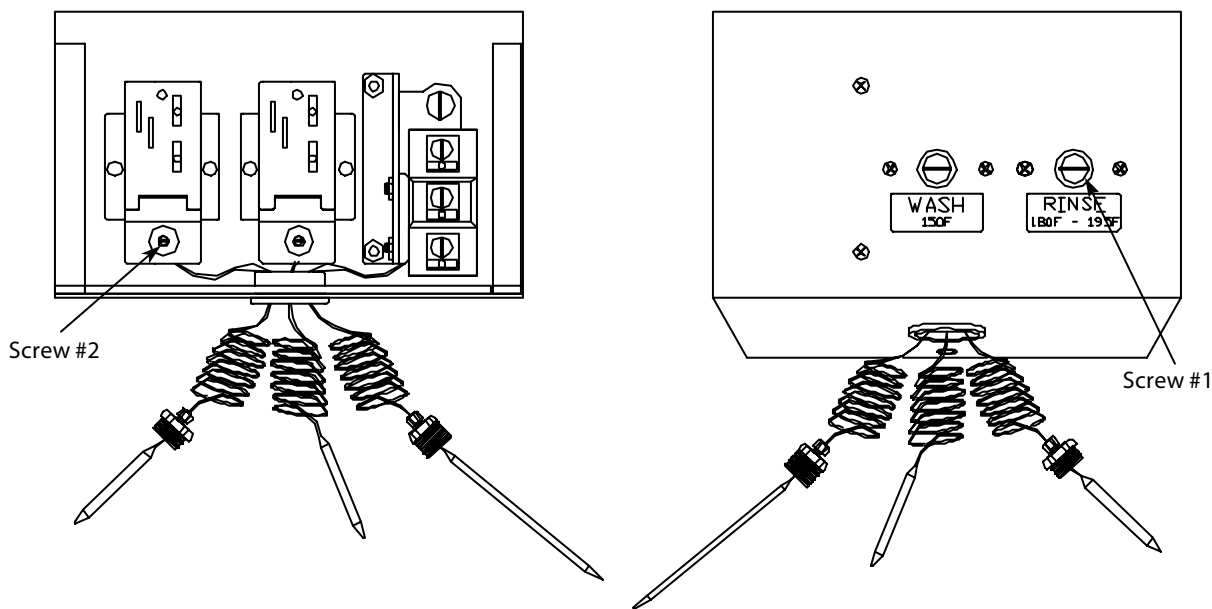

Thermostats can be ordered by using the following numbers:

- | | |
|------------------|-----------------|
| Rinse Thermostat | 05930-510-02-00 |
| Wash Thermostat | 05930-510-01-00 |

RINSE TANK HEATER SYSTEM:

The rinse tank heater system is electrically connected in the circuit and is controlled by a heat switch (mounted on the front panel) and a thermostat (mounted near the right front leg underneath) which activates the coil on the heat relay, mounted in the control box. When higher temperature is required, power is applied to the heaters (mounted on the right end of built-in boosters) when the contacts of the heat relay are closed. Should the rinse tank thermometer read either too high or too low, follow checkout below.

CAUTION: ALWAYS REMOVE THE POWER TO THE MACHINE BEFORE WORKING ON THE CONTROL PANEL OR WHILE SERVICING THE COMPONENTS ON THE SWITCH PANEL. ALL ELECTRICAL CHECKS SHOULD BE MADE BY QUALIFIED PERSONNEL.

CHECKOUT OF HEATER SYSTEM FOR RINSE TANK (refer to diagram on pg. 24)

NOTE: THE FOLLOWING CHECKOUT SHOULD BE DONE BY A QUALIFIED SERVICE PERSON OR ELECTRICIAN.

1. If temperature is too high, adjust thermostat using thermostat instructions in this manual.
2. If temperature is too low, adjust thermostat using thermostat instructions in this manual then:
 - a. Turn off power to machine by tripping customer circuit breaker to "off" position.
 - b. Remove lower cover plate on control box (held by a single screw).
 - c. Make sure rinse temperature is below 180°F (preferably about 140°F).
 - d. Re-apply power, turn on master switch and observe heat relay (2 pole mounted at the lower left inside control box) letter "C" figure 1 as heat switch is turned on and off several times.

NOTE: ELECTRICAL POWER STILL APPLIED, SO BE CAREFUL. (See instructions in manual for removing control panel front. Refer to replacement of switch in control panel.)

1. If heat relay contacts do not close: With heat switch on:
 - a. Check power supply at Position 1 on terminal board X. Voltage should be 208-230 VAC. If not, check customer's breaker, if defective, replace.
 - b. Check position 2, voltage should be 0 volts. If not, check thermostat, adjust per instructions, check master and heat switch, if any items are defective, replace.
 - c. Check position 3, there should be 208-230 Volts there. If not, check wiring for breaks or poor connections.
 - d. If voltage is being applied to Positions 1 and 3 and the relay doesn't operate, it should be replaced, coil on relay is probably open.

RINSE TANK HEATER SYSTEM (CONTINUED):

NOTE: A CHECK WITH AN AMP PROBE (POSITION E), IF AVAILABLE, WOULD BE HELPFUL AT THIS POINT.

2. To determine if elements are working, if heat relay does not close:
 - a. There is an insulated movable bar on the heat relay across the top of the two contacts. With an insulated probe, depress the bar and observe the rinse thermometer, the temperature should rise noticeably in a minute or two. If it move VERY slowly, it would indicate that one element is defective. If it moves consistently higher at a steady rate, elements are okay.
 - b. Check voltage at position 4. There should be 208-230 Volts. If not, check wiring.

Clamp probe on single wire between heat relay and heater elements. The elements together on a single phase should draw 30 amps, one element will draw only 10 amps. Replace element if found inoperative.

3. If relay is closed, but elements do not heat, use same general methods used in step 2 above for checkout.

- A. Heater switch
- B. Thermostat
- C. Heater Relay
- D. Rinse Tank Heaters
- E. Amprobe Test Position
- X. Terminal board (9 terminals)

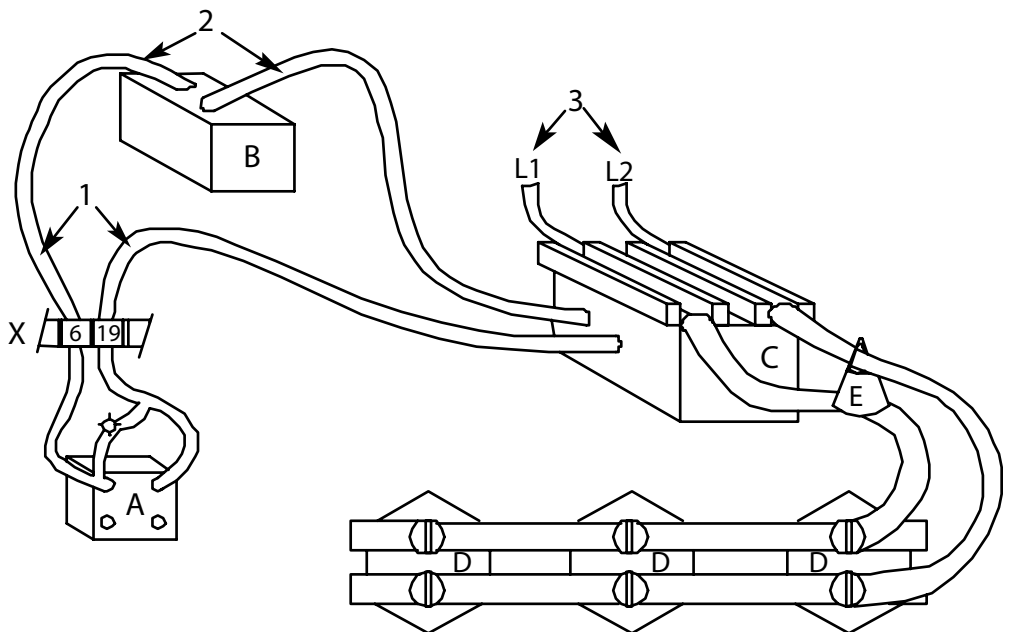

WASH TANK HEATER SYSTEM:

The wash tank heater control system is electrically connected in the circuit to operate on 208-230 Volts. The heat circuit is controlled by a heat switch (mounted right front panel), water level control (mounted top inside control box), and thermostat (mounted right front leg underneath). When higher temperature is required, power is applied to the heater element through above controls. Should the wash tank thermometer read too high or too low, follow checkout below.

CHECKOUT OF HEATER SYSTEM FOR WASH TANK (refer to diagram on next page)

NOTE: THE FOLLOWING CHECKOUT SHOULD BE DONE BY A QUALIFIED SERVICE PERSON OR ELECTRICIAN.

1. Ready the machine for normal dish washing operation with the wash tank water at proper level.
2. If temperature is too high, adjust thermostat using thermostat instructions in this manual.
3. If temperature is too low, adjust thermostat using thermostat instructions in this manual then:

NOTE: ELECTRICAL POWER STILL APPLIED, SO BE CAREFUL. (See instructions in manual for removing control panel front. Refer to replacement of switch in control panel.)

- a. With circuit breaker, master switch and heat switch on, check power to machine at position 1, terminal board "X" should read 208-230 Volts, if not, check customer's circuit breaker, if defective, replace.
 - b. Wash temperature should be 130°F or less to proceed.
 - c. Observe water level control, letter "D". Turn hat switch on and off several times. Relay and contact points (inside clear case on heat water level control) should move back and forth.
1. If water level control relay doesn't close, (contact points don't move in "C" above.
 - a. Refer to page on Water Level Control's function and checkout.
 2. If water level control relay does close, proceed with heat switch on:
 - a. Check voltage at position 1 on terminal board "X". Voltage is 208-230 Volts.
 - b. Check position 2, there should be no voltage. If there is voltage, then adjust thermostat (refer to page 22 on Thermostat Adjusting).
 - c. Check position 3, voltage should be 208-230 Volts. If not, check wiring for loose connections or a break.
 - d. Temperature should rise slowly, a check with an amprobe would indicate if the element is drawing the correct amperage. Replace element if defective

WASH TANK HEATER SYSTEM (CONTINUED):

Clamp probe on a single wire between the thermostat and wash heater element. The element should draw 3 amps. If it does not and everything above checked out okay, replace the element. This wash element is used to maintain wash water temperature so temperature rise will be extremely slow - do not depend on this indication.

NOTE: A CHECK WITH AN AMP PROBE (POSITION E), IF AVAILABLE, WOULD BE HELPFUL AT THIS POINT.

- A. Heater switch
- B. Thermostat
- C. Heater Relay
- D. Rinse Tank Heaters
- E. Amprobe Test Position
- X. Terminal board (9 terminals)

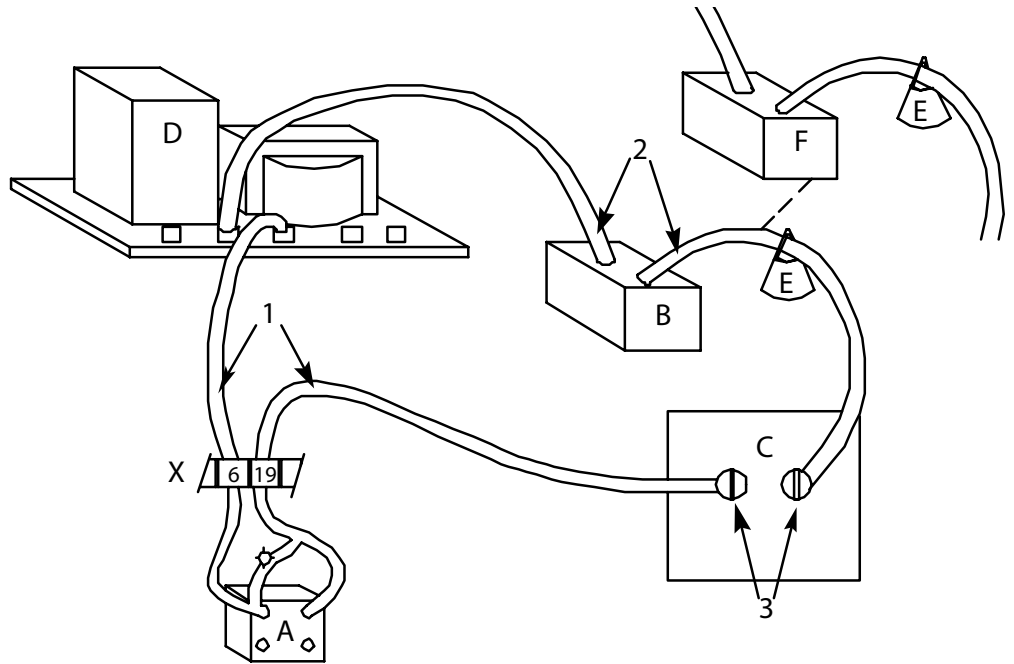

WATER LEVEL CONTROL: This water level control is used on this machine in conjunction with a sensor, master switch, thermostat all of which help control the action of the wash tank heater. The wash heater water level control is energized when the master switch is turned on.

When the water level decreases in the wash tank, the sensor (probe) sends a signal to the control which deactivates the plug-in relay (located on the control circuit board). When the relay deactivates, one set of its contacts return to a normally open position. The thermostat and wash heater are connected in series with these contacts and at this time de-energizes the wash tank heat circuit (thermostat & wash heaters). When the proper water level is restored the relay reactivates and closes the normally open contacts to energize the wash-heat circuit. Note: The master & heat switch must be on and the wash tub full to the probe level for the wash-heat circuit to work.

SYMPTOMS OF LEVEL CONTROL FAILURE:

1. Wash-heat circuit not energized by control. (Wash temperature not maintained by heater.)
2. Wash heater stays on with machine master and heat switch on yet no water in wash tub.

PROCEED WITH CHECKOUT:

1. Remove power to machine by turning circuit breaker to its "OFF" position.
2. Remove the 4 screws holding the control panel on the control box. Remove panel and attach to one side of control box with 2 screws.
3. Locate wash-heat water level control board and disconnect wires going to terminals marked C & H. Mark and insulate wires for replacement.
4. Re-apply power to machine. With an insulated jumper wire, touch jumper between terminals C & H, relay in clear plastic cube should activate as wire touched to terminals, observe relay contacts, they should pull in.
5. If relay operates, the control can be deemed operational and other causes should be explored. EXAMPLE: Wash element (open ore shorted) thermostat is defective or needs adjustment. See thermostat page for checkout.
6. If relay does not operate, replace control to see voltage is being applied to L1 - L2 marked on control.
7. In any case, always locate sensor (probe) inside wash tub and clean off all deposits (instruct customer, this should be done on a weekly basis).
8. Other checks can be made using the wash tank heater system checkout shown on another page.
9. Remove power to machine and replace wires that were removed in the steps above.

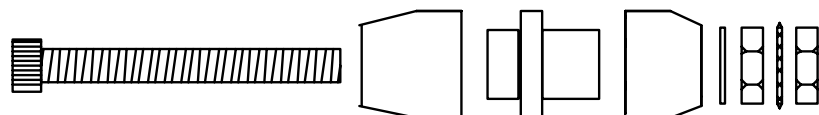

SENSOR, LUNDY PROBE

**WATER LEVEL CONTROL
(CONTINUED):**

The water control is used on this machine in conjunction with a sensing probe, to detect the water level in the rinse tank, and to control the automatic refilling of it.

When the water level decreases as the rinse pump starts to push water through the rinse tubes, the probe then sends a signal to the control which deactivates the plug-in relay (located on the control circuit board). When the relay deactivates, its contacts return to a normally closed position. The solenoid valve is connected in series with these contacts and at this time energizes to allow water to refill the rinse tank to the proper level. Then the relay activates and opens the normally closed contacts to deactivate the solenoid valve.

SYMPTOMS OF LEVEL CONTROL FAILURE:

1. Water level in rinse tank is not maintained, indicated by diminishing rinse spray halfway through its cycle.
2. Water continues to run at the end of the rinse cycle or water continues to spray out of the rinse tubes.

PROCEED WITH CHECKOUT:

1. Remove power to machine by turning circuit breaker to its "off" position.
2. Remove 4 screws holding control panel on control box. Remove panel and attach to one side of control box with 2 screws.
3. Locate water level control board and disconnect wires going to terminals marked C & H. Mark and insulated wires for correct placement.
4. Re-apply power to machine. With an insulated jumper wire, touch jumper between terminals C & H, relay in clear plastic cube should activate as wire touched to terminals, observe relay contacts, they should pull in.
5. If relay operates, the control can be deemed operational and other causes should be explored. EXAMPLE: Solenoid valve not functioning properly, loose or broken wires in circuit, sensing probe malfunctioning, or loose green ground wire.
6. If relay does not operate, replace control.
7. Remove sensing probe from rinse tank and clean any deposits that may have built up causing it to malfunction.
8. If solenoid valve does not open or remains open, see instructions on separate page to check, clean or repair.
9. Remove power to machine and replace wires that were removed in above steps.

Water Level Control Board
06680-200-01-19

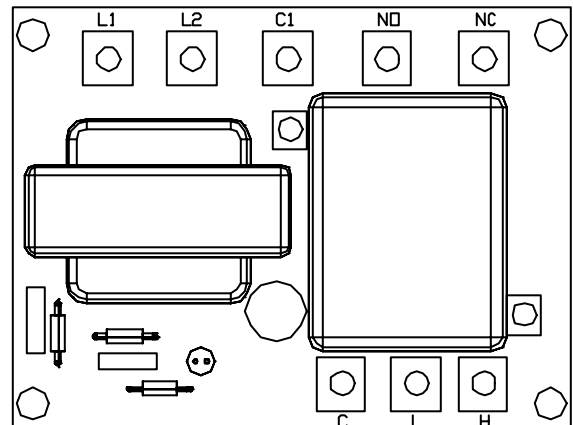

REPLACING SEAL AND CERAMIC ON WASH AND RINSE PUMPS:

The pump is part of the total motor-pump system and utilizes one seal and ceramic to prevent the pump from leaking around the impeller and shaft. One gasket is used to prevent leakage in between the pump and mounting plate and the machine pump plate.

REPLACEMENT of SEAL and/or CERAMIC:

1. Remove power source to machine by turning circuit breaker to its off position on side of control box.
2. Drain machine by removing overflow strainer in wash tank.
3. Support motor, and remove the four nuts holding the pump/motor to the machine's pump plate.
4. Carefully pull motor outward, move from side to side as required to remove from the machine.
5. Set motor and pump on a sturdy stand close to machine or remove wires and conduit to allow motor/pump to be moved to a better work position.
6. Remove dust cap over end of motor shaft (opposite impeller end). This can be done by wedging with a screwdriver.
7. Remove impeller. Hold shaft by inserting screw driver in slotted end of shaft and unscrew impeller in counter clockwise direction.
8. The ceramic is embedded in the impeller and normally does not need replacement, but it should be checked for cracks or a worn out surface. If the ceramic does need replacement, proceed as follows.
 - a. With a pointed, flat tool, work the ceramic and rubber cap out of groove in impeller.
 - b. Clean groove of all residue.
 - c. Apply a small amount of adhesive in groove.
 - d. Press new ceramic gently into groove with rubber cap leading the way.

(NOTE: THE CERAMIC HAS ONE SIDE THAT IS HAS A GROOVE IN IT. THIS SIDE SHOULD BE FACING DOWN INTO THE RUBBER CAP. THE SMOOTH SURFACE SHOULD BE FACING UP).

9. The seal is embedded in the pump mounting plate and usually will need replacement when water leaks around the motor shaft area. If replacement is required proceed as follows.
 - a. Remove the four bolts holding the pump mounting plate to the motor, must done with an allen wrench.
 - b. Slide mounting plate up off of shaft and motor.
 - c. Press seal out of housing carefully.

**REPLACING SEAL
AND CERAMIC
ON WASH AND
RINSE PUMPS
(CONTINUED):**

- d. Clean hole where seal was installed.
- e. Apply a small amount of non-hardening sealant to the backside of seal.
Insert new seal with a seal driver to prevent ruffling the edges of the seal.
Never use a screwdriver or similar tool to alternately force edge of seal in place.

10. Reassemble pump and motor by reversing the above procedure.

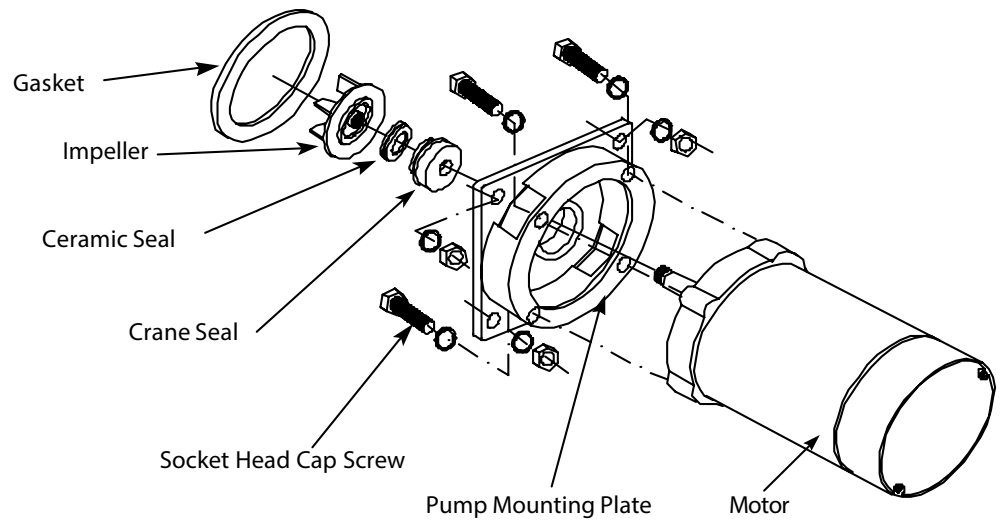

PROBLEM	POSSIBLE CAUSE	REMEDY
Nothing on the machine operates.	<ol style="list-style-type: none"> 1. No voltage to the dishmachine. Check to see if the customer's fuse has blown or the circuit breaker has tripped. 2. Machine circuit breaker tripped or turned off. 3. Voltage to machine low or circuit to machine broken. 	<ol style="list-style-type: none"> 1. Replace or reset. 2. Turn on or reset. 3. Contact your electrician and/or power company for repair.
Machine will not fill with electrical power applied, even though other components work. (AB Model)	<ol style="list-style-type: none"> 1. Water hand valve off. 2. Master switch not on or faulty. 3. Fill switch faulty or loose wire connection. 4. Solenoid valve does not operate. 5. Y-Strainer is clogged. 	<ol style="list-style-type: none"> 1. Turn hand valve on. 2. Turn on or replace. 3. Replace switch or wire or connection terminal. 4. See instructions page concerning the solenoid valve. 5. Turn water to machine off, remove plug and strainer screen, clean and replace.
Machine will not fill with electrical power applied even though other components work. (APRB Model)	<ol style="list-style-type: none"> 1. Water hand valve off. 2. Master switch not on or faulty. 3. Fill switch faulty or loose wire connection. 4. Rinse motor not operating. 5. Water level control does not maintain the water level in the rinse tank. 6. Solenoid valve does not operate. 7. Y-Strainer is clogged. 	<ol style="list-style-type: none"> 1. Turn hand valve on. 2. Turn on or replace. 3. Replace switch or wire or connection terminal. 4. Check connection and voltage to motor repair or replace as necessary. 5. See instruction page concerning the water level control for APRB Models. 6. See instructions page concerning the solenoid valve. 7. Turn water to machine off, remove plug and strainer screen, clean and replace.
Machine fills slowly and/or rinse is weak.	<ol style="list-style-type: none"> 1. Low water pressure. 2. Rinse head assemblies limed up or clogged with other deposits. 	<ol style="list-style-type: none"> 1. Check water pressure by first, turning the heat and master switch off. Next, empty the wash tub. Then turn the master switch on, and as you push up the fill switch, time the seconds it takes to fill the machine to the top of the overflow tube. It should be 35 seconds. Any more than 5 seconds longer indicates the water supply and pressure and insufficient. 2. Clean rinse head tubes by removing end plugs and push the cleaning brush through to clean.
Rinse water runs continuously with power on.	<ol style="list-style-type: none"> 1. Rinse switch sluggish or faulty. 2. Solenoid valve dirty or faulty. 3. Water level control faulty (APRB Models only). 4. Rinse tank probe coated. (APRB Models only) 5. Breather tube plugged or bent closed. (APRB Model only) 	<ol style="list-style-type: none"> 1. Replace. 2. See special instructions page concerning the solenoid valve. 3. See special instructions page concerning the water level control for APRB Models. 4. Remove and clean probe then replace. 5. Clean or replace tube.

PROBLEM	POSSIBLE CAUSE	REMEDY
Rinse water temperature too low (less than 180°F).	<ol style="list-style-type: none"> Incoming water temperature under required 140°F. Heat switch, relay thermostat or elements faulty. 	<ol style="list-style-type: none"> Check incoming water temperature by first turning off heat switch, then drain the machine wash tub. Next, with the master switch, push the fill switch up and hold 1 and a half minutes (90 seconds). Release the fill switch and read the rinse thermometer. The temperature should read 140°F or higher. If it is not this temperature, then the customer's supply water heater temperature must be adjusted to provide proper temperature. See instructions page concerning Rinse Tank heater system.
Problem: Rinse water temperature too hot (over 200°F) and water may dribble out of the rinse heads from time to time.	<ol style="list-style-type: none"> Thermostat needs adjustment or is faulty. Heat relay contacts welded or held shut. 	<ol style="list-style-type: none"> See instructions page concerning thermostat adjustment. Remove power and alter cause, holding contacts closed or replace relay if needed.
Vacuum breaker leaks.	<ol style="list-style-type: none"> Limed up. Faulty. 	<ol style="list-style-type: none"> To disassemble: Use flat jaw wrench or channel locks. Remove the poppet. Clean poppet, top, and body. Reassemble parts removed. Replace needed parts or whole vacuum breaker.
Wash arms spray water but do not rotate.	<ol style="list-style-type: none"> Wash cap adjusted too tight. Race ways where ball bearings rotate rough or full of food particles. 	<ol style="list-style-type: none"> See instructions page concerning removal of rinse and wash head assemblies. See instructions page concerning removal of rinse and wash head assemblies. <ol style="list-style-type: none"> Race ways where ball bearings rotate rough or full of food particles. See instructions page concerning removal of rinse and wash head assemblies while apart. Clean race way with emery cloth or fine sandpaper. Soak ball bearings in lime dissolving solution, rinse and dry with a lint free towel.
Wash water only spray up and out of tubes a couple of inches.	<ol style="list-style-type: none"> Overflow strainer clogged or pump intake strainer clogged. Pump impeller worn or broken (only after many years of use). Obstruction in pump chute or wash manifold. 	<ol style="list-style-type: none"> Remove overflow strainer. When the wash tub is empty, reach in opening (where the overflow was) and remove the pump intake strainer and clean thoroughly. See instructions page concerning seal and ceramic on wash and rinse pump for removal and inspection of impeller. Follow #2 above to remove pump then check chamber and manifold.
Wash motor or rinse motor (APRB Model only) does not operate.	<ol style="list-style-type: none"> Faulty 	<ol style="list-style-type: none"> Checkout and remove for motor repair if necessary.
Wash water temperature too low (below 150°F).	<ol style="list-style-type: none"> Rinse water temperature too low. Thermometer faulty. 	<ol style="list-style-type: none"> Raise rinse water temperature to a max of 196°F using instruction page concerning thermostat adjustment. See instructions page concerning Rinse Tank heater system.

PROBLEM	POSSIBLE CAUSE	REMEDY
Problem: Rinse water temperature too hot (over 200°F) and water may dribble out of the rinse heads from time to time.	<ol style="list-style-type: none"> 1. Thermostat needs adjustment or is faulty. 2. Heat relay contacts welded or held shut. 3. Water level control faulty. 4. Wash heater faulty. 5. Thermostat faulty 	<ol style="list-style-type: none"> 1. See instructions page concerning thermostat adjustment. 2. Check thermometer and replace if necessary. 3. See instruction page concerning water level control (wash heat circuit). 4. See instruction page concerning wash tank heater system. 5. See instruction page concerning wash tank heater system.
Water flow near rinse tank indicating leak.	<ol style="list-style-type: none"> 1. Hood support pipe does not have two (2) O-rings below the support nut. 2. Hood support block (center back of wash tub) is leaking. 3. Hood support nut not down tight against washer, gasket, and table. 	<ol style="list-style-type: none"> 1. The hood must be removed to check and replace the o-rings, but be sure the leak is coming from there before proceeding. 2. Tighten the screws from the inside of the tub. Sometimes you can remove the screws one at a time and fill the holes with a non-hardening, food zone safe sealant and replace screws. 3. Tighten down.
Hood scrapes when opened.	<ol style="list-style-type: none"> 1. Machine not level. 2. Hood not centered. 3. Hood too low. 4. Inside adjustment nut too loose or tight. 	<ol style="list-style-type: none"> 1. Make sure rim of dishwasher tight up against table all around by loosening or tightening bullet feet on machine and table. 2. Remove upper spray head assembly and insert a 1/2" by 9" or more nipple. With pressure on nipple, force hood away from where it rubs. 3. Raise arm by using pressure on hood arm upward. 4. Turn washer lock tab up and rotate spanner nut to tighten or loosen then bend tab to lock spanner in place.
Water sprays from lower rinse arms after end of each cycle.	<ol style="list-style-type: none"> 1. Water pressure too high holding solenoid valve open. 2. Water temperature set too high in rinse tank. 3. Internal vacuum breaker pipe not in hood support arm. 	<ol style="list-style-type: none"> 1. Check and install pressure reducer if necessary. 2. See instructions page concerning thermostat adjustment. 3. See illustration on page concerning hood support pipe.
Indicator lights do not glow at any time.	<ol style="list-style-type: none"> 1. Lights faulty or poor connection. 	<ol style="list-style-type: none"> 1. Replace or correct connection.
None of the automatic functions work (wash, rinse).	<ol style="list-style-type: none"> 1. Start switch faulty. 2. Wire connections poor. 3. Timer rinse or wash microswitch faulty. 	<ol style="list-style-type: none"> 1. Replace if necessary, see instructions page concerning replacement of switches in control panel. 2. Correct the connection. 3. See instructions page concerning timer and motor.

PROBLEM	POSSIBLE CAUSE	REMEDY
Rinse does not work when manual rinse fill switch operated, but does work during automatic cycle.	<ol style="list-style-type: none"> 1. Normally open contact on rinse fill switch faulty. 2. Wire connection poor. 	<ol style="list-style-type: none"> 1. See instruction page concerning replacement of switches in control panel. 2. Correct the connection.
Wash does not work on automatic cycle, but does on manual wash.	<ol style="list-style-type: none"> 1. Normally closed contacts on wash switch faulty. 2. Wire connections poor. 3. Timer rinse or wash microswitch faulty. 	<ol style="list-style-type: none"> 1. See instruction page concerning replacement of switches in control panel. 2. Correct the connection. 3. See instructions page concerning timer and motor.
Wash does not work when manual wash switch operated but does work during the automatic cycle.	<ol style="list-style-type: none"> 1. Normally open contact on wash switch faulty. 2. Wire connection poor. 	<ol style="list-style-type: none"> 1. See instruction page concerning replacement of switches in control panel. 2. Correct the connection.
When master switch is turned on either it washes continuously or rinses continuously.	<ol style="list-style-type: none"> 1. Timer motor faulty and cams are not turning holding it in the mode it is in. 	<ol style="list-style-type: none"> 1. See instruction page on the timer & timer motor.
Wash tub water level continuously lowers.	<ol style="list-style-type: none"> 1. Large overflow strainer not seated properly. 2. O-ring in drain fitting is missing. 3. Deposit build up on drain fitting or O-ring. 4. Bottom of overflow strainer (conical end of tube) bent out of shape. 	<ol style="list-style-type: none"> 1. Remove and insert with a slight twisting action. 2. Replace. See illustration on page concerning overflow strainer and drain o-ring. 3. Clean. 4. Replace strainer.

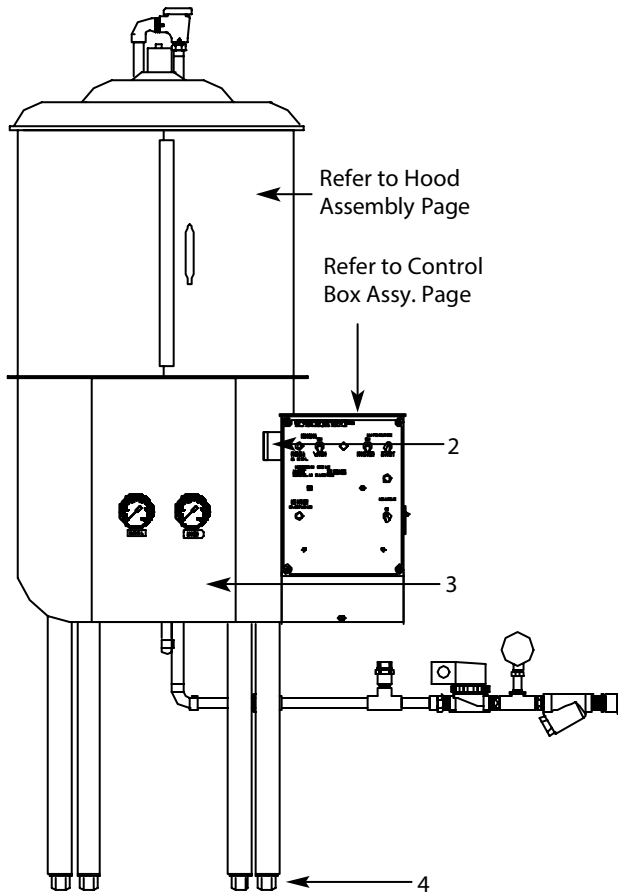

FRONT VIEW ASSEMBLY

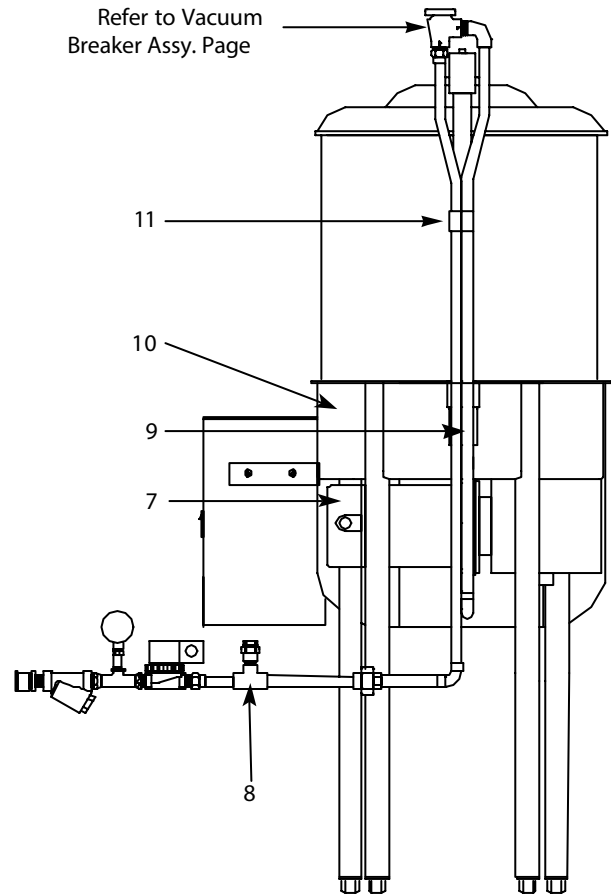

REAR VIEW ASSEMBLY

ITEM	QTY	DESCRIPTION	PART NUMBER
1	1	Hood Assembly	N/A
2	1	Control Box Support Bracket	05700-000-24-76
3	1	Shroud	05700-000-24-77
4	4	Bullet Feet	05340-108-01-03
5	1	Complete Control Box Assembly	N/A
6	1	Vacuum Breaker Assembly	N/A
7	1	Motor and Pump Assembly	05700-002-60-91
8	1	Incoming Plumbing Assembly	05700-002-60-98
9	1	Outlet Connector	05700-002-61-19
10	1	Tub Weldment Assembly 10A	05700-002-60-95
10	1	Tub Weldment Assembly 10A (9" Shorter Leg)	05700-002-62-00
11	2	Bracket, Vacuum Breaker Support	05700-000-32-27

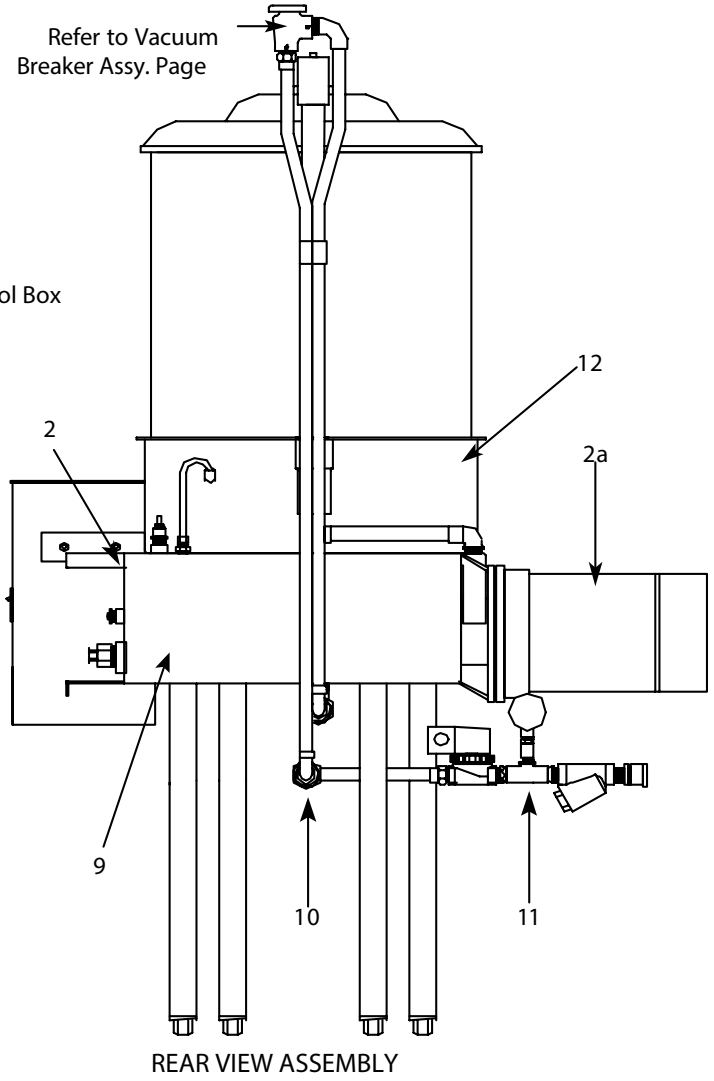
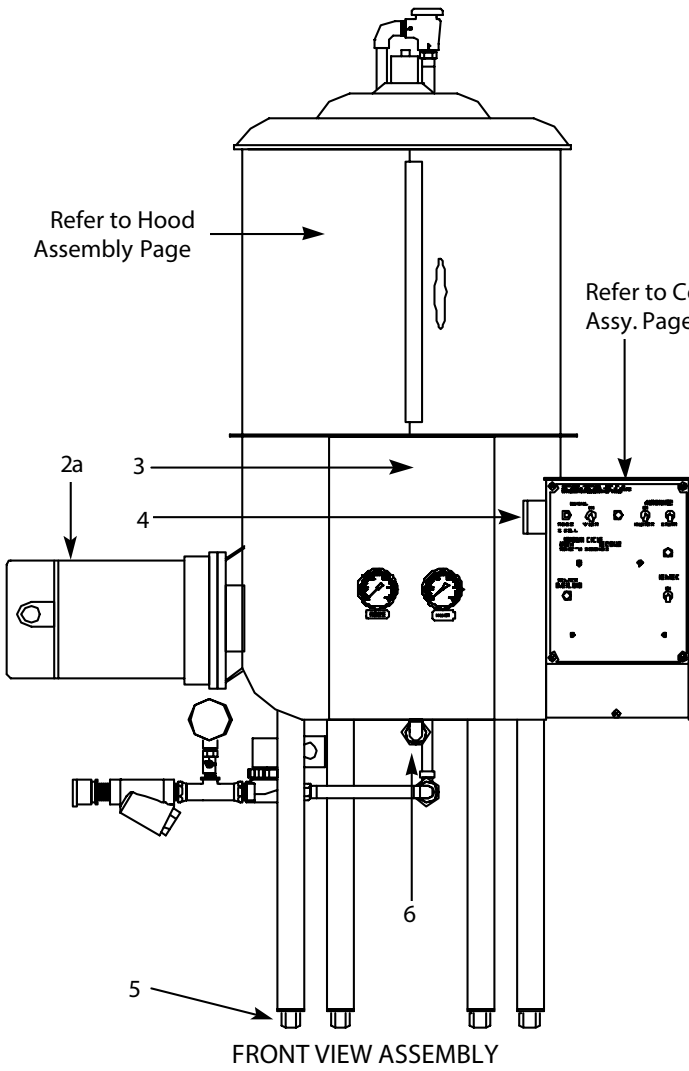

ITEM	QTY	DESCRIPTION	PART NUMBER
1	1	Hood Assembly	N/A
2	1	Motor and Pump Assembly	05700-002-60-91
	1	Motor and Pump Assembly (APRB only)	05700-002-60-91
3	1	Shroud (without holes for gauges)	05700-000-24-77
3	1	Shroud (with holes for gauges)	05700-002-60-36
4	1	Control Box Support Bracket	05700-000-24-76
5	4	Bullet Feet	05340-108-01-03
6	1	Outlet Connector	05700-002-60-92
7	1	Complete Control Box Assembly	N/A
8	1	Vacuum Breaker Assembly	N/A
9	1	Rinse Tank Assembly	05700-000-24-84
9	1	Rinse Tank Assembly (APRB Only)	05700-000-24-80
10	1	Inlet Connector	05700-002-60-93
11	1	Incoming Plumbing Assembly	05700-000-15-25
12	1	Tub Weldment Assembly 10AB	05700-000-57-73
	1	Tub Weldment Assembly 10AB (9" shorter leg)/10U	05700-002-60-94
	1	Tub Weldment Assembly 10APRB	05700-000-57-74
	1	Tub Weldment Assembly 10APRB (9" shorter leg)	05700-002-62-01

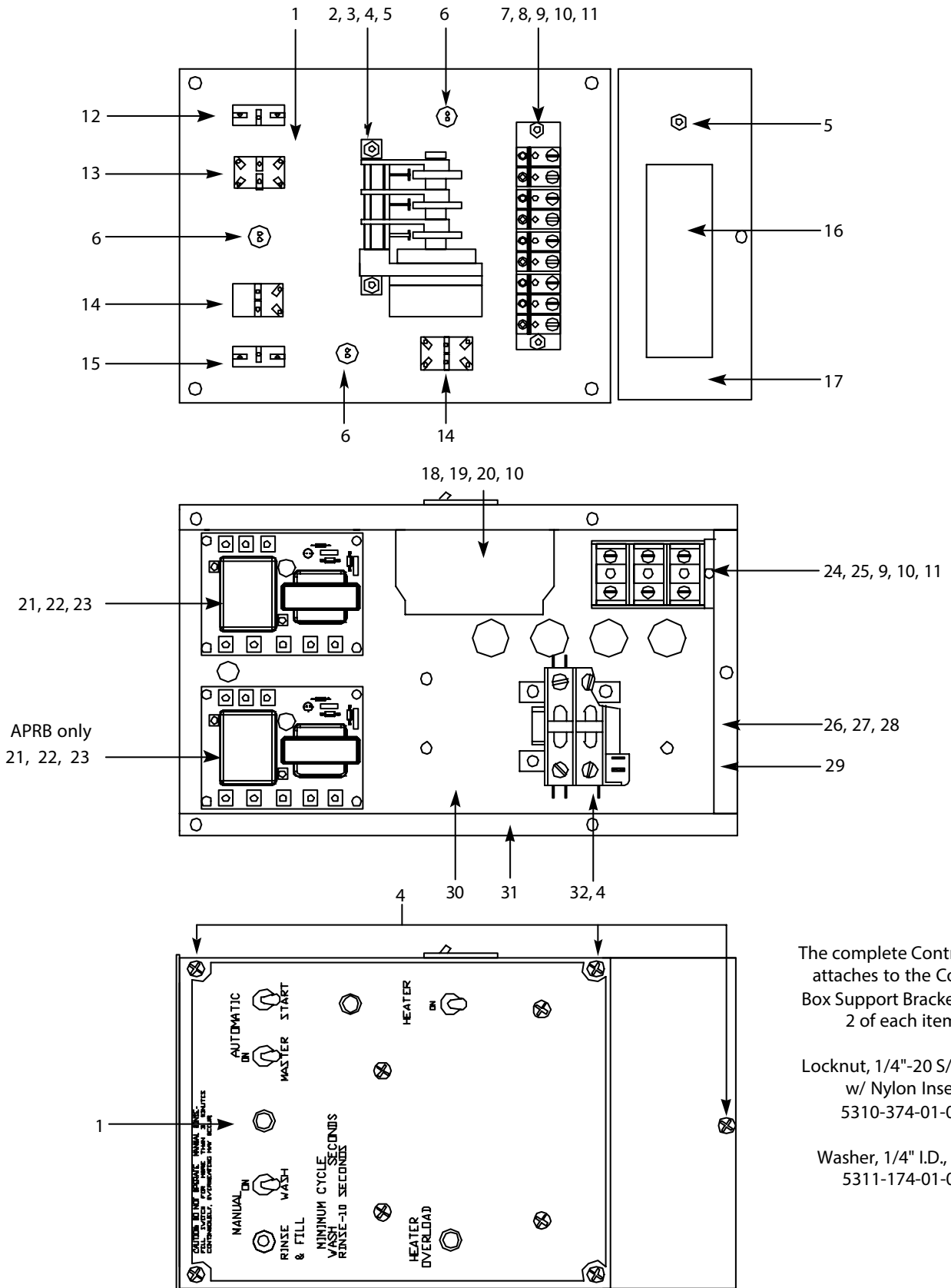

The complete Control Box attaches to the Control Box Support Bracket with 2 of each item:

Locknut, 1/4"-20 S/S Hex w/ Nylon Insert
5310-374-01-00

Washer, 1/4" I.D., S/S
5311-174-01-00

CONTROL BOX ASSEMBLY

PARTS

ITEM	QTY	DESCRIPTION	Mfg. No.
1	1	Control Box Panel with Decal	09905-500-07-10
2	1	Timer	05945-303-19-00
3	1	Bracket, Timer Mounting	05700-000-34-28
4	4	Screw, 10-32 x 3/8" Phillips Truss Head	05305-173-12-00
5	4	Locknut, 10-32 S/S Hex with Nylon Insert	05310-273-01-00
6	3	Light, Pilot	05945-504-02-18
7	1	Block, 9 Position Terminal	05940-500-06-19
8	1	Decal, Terminal Block	09905-100-87-62
9	2	Screw, 8-32 x 3/8" Round Head	05305-172-02-00
10	6	Lockwasher, #8 External Tooth	05311-272-01-00
11	2	Nut, Hex 8-32	05310-272-01-00
12	1	Switch, Rinse	05930-301-20-18
13	1	Switch, Wash	05930-301-21-18
14	2	Switch, Master	05930-301-22-18
15	1	Switch, Start	05930-301-23-18
16	1	Decal, Schematic, 10A	09905-002-57-63
16	1	Decal, Schematic, 10AB/10U, 1 Phase	09905-105-33-59
16	1	Decal, Schematic, 10AB/10U, 3 Phase	09905-105-34-47
16	1	Decal, Schematic, 10APRB, 1 Phase	09905-105-33-62
16	1	Decal, Schematic, 10APRB, 3 Phase	09905-105-34-50
17	1	Panel, Control Box Front & Bottom	05700-000-24-30
18	1	Circuit Breaker, 15 Amp	05925-105-10-01
19	1	Plate, Circuit Breaker	05927-113-13-01
20	2	Screw, 8-32 x 1/4" Round Head Slotted	05305-172-01-00
21	1	Control, Water Level (2 for APRB option)	06680-200-01-19
22	4	Screw, 6-32 x 3/4" Phillip Pan Head (8 for APRB option)	05305-011-37-05
23	4	Lockwasher, #6 External Tooth (8 for APRB option)	05311-271-02-00
24	2	Block, Terminal (1 Phase Units)	05940-500-02-19
24	3	Block, Terminal (3 Phase Units)	05940-500-02-19
25	1	Track, Terminal Block, 3 5/16"	05700-000-43-60
26	1	Ground Lug	05940-200-76-00
27	1	Locknut, 10-24 S/S Hex with Nylon Insert	05310-373-01-00
28	1	Decal, Ground	09905-011-86-86
29	1	Decal, Copper Conductors	09905-011-47-35
30	1	Control Box Weldment, Right Hand	05700-000-27-99
30	1	Control Box Weldment, Left Hand	05700-002-49-62
31	3 feet	Rubber Strip, 1/2" x 1/8"	05330-100-10-00
32	1	Contactactor (1 Phase Units)	05945-002-74-20
32	1	Contactactor (3 Phase Units)	05945-109-06-69
32	N/A	Not used on 10A	N/A

Jackson dishmachines have several color and gauges of wire used in them and it may become necessary to replace these wires. Wire may be ordered from Jackson, but please note that it is only available in feet. Ensure that you order the correct color and gauge.

BLACK WIRE:	6 Gauge	06145-002-15-91
	8 Gauge	06145-104-43-00
	10 Gauge	06145-104-16-00
	12 Gauge	06145-112-01-00
	14 Gauge	06145-104-09-00
	18 Gauge	06145-104-01-97
	18 Gauge with Orange Stripes	06145-011-35-66
	18 Gauge with White Stripes	06145-011-35-65
	18 Gauge with Yellow Stripes	06145-011-35-64

BLUE WIRE:	6 Gauge	06145-002-15-93
	8 Gauge	06145-104-44-00
	10 Gauge	06145-104-42-00
	14 Gauge	06145-104-04-00
	18 Gauge	06145-104-35-00
	18 Gauge with Black Stripes	06145-011-46-35
	18 Gauge with Red Stripes	06145-011-46-37
	18 Gauge with White Stripes	06145-011-46-36
	18 Gauge with Yellow Stripes	06145-011-46-38
	20 Gauge	06145-104-06-97
	20 Gauge with Black Stripes	06145-104-17-97
	20 Gauge with White Stripes	06145-104-13-97

GREEN WIRE:	6 Gauge	06145-002-15-94
	14 Gauge	06145-104-03-00
	18 Gauge	06145-104-32-00
	18 Gauge with Yellow Stripes	06145-001-44-96
	20 Gauge	06145-104-05-97
	20 Gauge with Black Stripes	06145-011-59-57
	20 Gauge with Yellow Stripes	06145-104-11-97

GREY WIRE:	18 Gauge	06145-104-36-00
	18 Gauge with Black Stripes	06145-011-81-71
	18 Gauge with Blue Stripes	06145-011-81-72
	18 Gauge with Red Stripes	06145-011-46-41
	18 Gauge with White Stripes	06145-011-35-60
	18 Gauge with Yellow Stripes	06145-011-46-42
	20 Gauge	06145-104-03-97

RED WIRE:	6 Gauge	06145-002-15-92
	8 Gauge	06145-104-45-00
	10 Gauge	06145-104-08-00

RED WIRE: (CONTINUED)	14 Gauge	06145-104-05-00
	18 Gauge	06145-104-37-00
	18 Gauge with Black Stripes	06145-011-59-56
	18 Gauge with Blue Stripes	06145-011-81-74
	18 Gauge with White Stripes	06145-011-81-73
	18 Gauge with Yellow Stripes	06145-011-81-75
	20 Gauge	06145-104-02-97

WHITE WIRE:	10 Gauge	06145-002-15-91
	14 Gauge	06145-104-43-00
	18 Gauge	06145-104-16-00
	18 Gauge with Black Stripes	06145-011-35-70
	18 Gauge with Blue Stripes	06145-011-46-40
	18 Gauge with Green Stripes	06145-011-35-69
	18 Gauge with Grey Stripes	06145-002-20-18
	18 Gauge with Red Stripes	06145-011-35-67
	18 Gauge with Yellow Stripes	06145-011-35-68
	20 Gauge	06145-104-04-97
	20 Gauge with Orange & Yellow Stripes	06145-104-16-97
	20 Gauge with Yellow Stripes	06145-104-15-97

YELLOW WIRE:	18 Gauge	06145-104-33-00
	18 Gauge with Black Stripes	06145-011-81-68
	18 Gauge with Blue Stripes	06145-011-81-70
	18 Gauge with Red Stripes	06145-011-81-69
	20 Gauge	06145-104-07-97

MISCELLANEOUS WIRE:	Brown (18 Gauge)	06145-104-20-00
	Brown (20 Gauge)	06145-104-08-97
	Orange (18 Gauge)	06145-104-34-00
	Orange with Black Stripes (18 Gauge)	06145-011-35-62
	Orange with Blue Stripes (18 Gauge)	06145-011-46-39
	Orange with White Stripes (18 Gauge)	06145-011-35-63
	Orange with Yellow Stripes (18 Gauge)	06145-011-35-61
	Orange (20 Gauge)	06145-104-10-97
	Pink (18 Gauge)	06145-011-82-69
	Purple (18 Gauge)	06145-104-31-00
	Violet (20 Gauge)	06145-104-09-97
	Plug, GFI	06145-001-97-90
	Cable, 16 Gauge, 3 Wire Romex	06145-011-98-29
	Cord, Hubble Plug MC	06145-011-47-23
	Cord, S-J	06145-011-49-02
	Cord, Power	06145-011-70-28
	Cord, 115V Power	06145-309-02-00
Cord, 125V Power, 96" Long	06145-309-04-00	

Jackson dishmachines come with a wide variety of conduit and fittings for use in routing the wires of the machine. The list below provides for most of stock of such items. When ordering, remember that Jackson does not offer pre-cut sections of conduit for your machine, instead it is sold by the foot. Please take into account the slack that will be necessary once installing the new conduit to ensure that it fits correctly. It is recommended that you order at least 6" more conduit than you require to ensure that you have enough for trimming. Tubing and hose are ordered by the foot. Jackson reserves the right to require minimum ordering quantities for the items below.

CONDUIT:	Conduit, 1/2", Liquidtite	05975-101-25-00
	Conduit, 1/2", Non-Metallic	05975-111-46-57
	Conduit, 1/2", PVC	05975-105-04-00
	Conduit, 1/2", Sealrite	05975-105-01-00
	Conduit, 1/2", Xtraflex	05975-105-06-44
	Conduit, 3/8", Liquidtite	05975-105-02-00
	Conduit, 3/4", Cole-Flex	05975-105-05-00
	Conduit, 3/4", Liquidtite	05975-105-03-00
	Conduit, 3/4", Non-Metallic	05975-011-47-71
	Conduit, 3/4" Xtraflex	05975-105-07-44
	Conduit, 1", Carlon	05975-011-68-42

CONDUIT	Elbow, Cole-Flex, 1/2", 90°	05975-205-40-00
FITTINGS:	Elbow, Xtraflex, 1/2", 90°	05975-205-44-44
	Elbow, Xtraflex, 3/4", 90°	05975-205-45-44
	Fitting, 1/2" Straight	05975-011-45-13
	Fitting, 1/2", Straight, Zinc Plated	05975-111-89-89
	Fitting, 1/2", 45°	05975-011-45-23
	Fitting, 1/2", 45°, Zinc Plated	05975-111-89-86
	Fitting, 1/2", 90°	05975-011-45-14
	Fitting, 1/2", 90°, Zinc Plated	05975-111-89-88
	Fitting, 3/4", Straight	05975-011-47-72
	Fitting, 3/4", 45°	05975-011-47-74
	Fitting, 3/4", 90°	05975-011-47-73
	Fitting, 1", Straight	05975-011-70-75
	Fitting, 1", 90°	05975-011-68-43
	Fitting, Cole-Flex, 1/2" Straight	05975-205-03-00
	Fitting, Cole-Flex, 3/4" Straight	05975-205-41-00
	Fitting, Cole-Flex, 3/4", 90°	05975-204-42-00
	Fitting, Liquidtite, .231 ID/.394 OD	05975-011-49-03
	Fitting, Liquidtite, .25 ID/.546 OD	05975-011-65-51
	Fitting, Liquidtite, .27 ID/.48 OD	05975-011-59-50
	Fitting, Liquidtite, 1/2", 90°	05975-111-01-00
	Fitting, Liquidtite, 3/8", Straight	05975-205-03-82
	Fitting, Liquidtite, 3/8", 90°	05975-205-02-82
	Fitting, Liquidtite, 3/4", Straight	05975-205-15-02
	Fitting, Liquidtite, 3/4", 45°	05975-205-01-82
	Fitting, Liquidtite, 3/4", 90°	05975-205-07-82
	Fitting, Xtraflex, 1/2", Straight	05975-205-47-44
	Fitting, Xtraflex, 3/4", Straight	05975-205-46-44
	Nut, 1-1/4"	05975-011-42-54

HOSE: Hose, 3/16" ID x 5/16" OD	04720-601-40-00
Hose, 1/4" ID x .062" Wall, Excelon	04720-111-59-46
Hose, 1/4" ID x 1/2" OD, 300-350 PSI	04720-011-95-43
Hose, 3/8" ID x 5/8" OD, 300 PSI	04720-002-31-63
Hose, 3/8" ID x 5/8" OD, PVC	04720-011-35-41
Hose, 3/8" ID x 3/4" OD, PVC	04720-111-35-41
Hose, 1/2" ID x 3/4" OD	04720-011-94-01
Hose, 1/2" ID, Reinforced	04720-011-63-06
Hose, 5/8" ID x 7/8" OD, PVC	04720-601-14-00
Hose, 3/4" ID x 1" OD	04720-011-94-10
Hose, 3/4" ID, Nylon Reinforced	04720-011-63-02
Hose, 1" ID x 1-1/4" OD, EPDM	04720-111-39-73
Hose, 1 1/4" ID x 1 1/2" OD, Reinforced	04720-601-42-00
Hose, 1 1/4" ID, Reinforced	04720-011-44-47
Hose, 1 1/2" ID, Clear Wire Reinforced	04720-111-34-60
Hose, 2" ID, Nylon Reinforced	04720-011-63-25
Hose, 2" ID, Reinforced Flex Drain	04720-011-63-04
Hose 2" ID x 3" OD, EPDM	04720-011-88-02

TUBING: Tubing, 1/8" OD, Paraflex	04720-111-58-09
Tubing, 3/16" ID x .54" OD, CPVC	04720-111-35-31
Tubing, 1/4" OD	04720-111-51-65
Tubing, 1/4" OD, Blue	04720-601-11-00
Tubing, 1/4" OD, Red	04720-601-12-00
Tubing, 1/4" OD, White	04720-601-13-00
Tubing, 1/4" OD, Paraflex	04720-111-51-70
Tubing, 1/4" ID x 3/8" OD, Tygon	04720-001-97-65
Tubing, 1/2" ID x 13/16" OD, Polypropolene	04720-601-24-00
Tubing, 5/16" x 7/16" OD, Clear	04720-111-35-34
Tubing, 5/16" ID x 1/2" OD, Flexible	04720-011-35-21
Tubing, 3/8" ID x 1/16" Wall, Clear	04720-601-22-00
Tubing, 3/8" OD, White Polypropolene	04720-011-50-49
Tubing, 5/8" ID with .125" Wall	04720-002-12-20
Tubing, 3/4" ID x 1/8" Wall, Polypropolene	04720-601-25-00
Tubing, 3/4" ID x 1-1/8" OD, Nylon	04720-001-84-01
Tubing, 1" Polybrade	04720-011-69-16
Tubing, 1" ID x 1-3/8" OD, Polypropolene	04720-601-23-00
Tubing, 1 1/2" Polybrade	04720-011-69-17

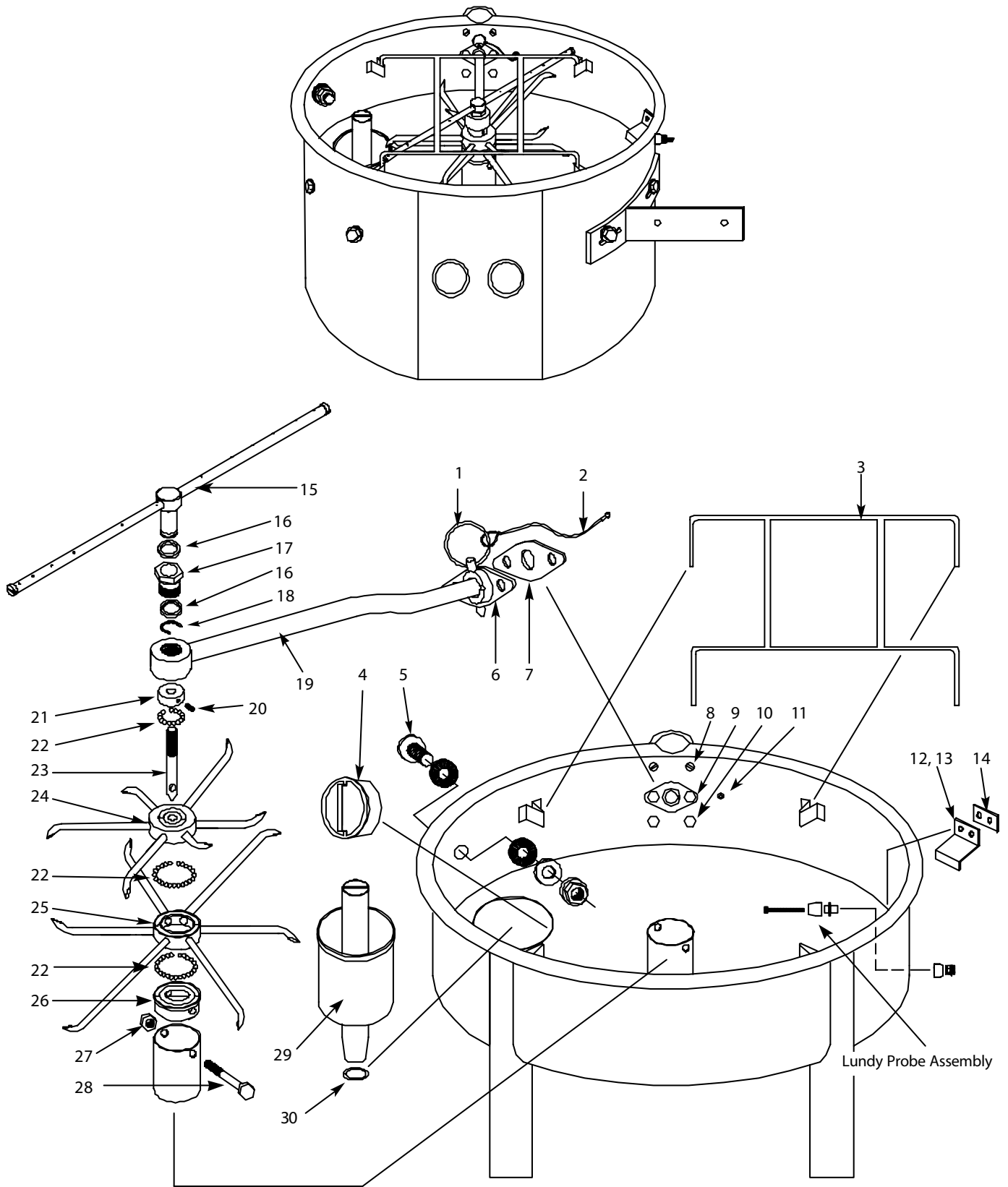

ITEM	QTY	DESCRIPTION	PART NUMBER
1	1	Wire Spring Ring	05315-700-03-00
2	1	Cable Assembly	03020-201-09-01
3	1	Support, Rack Weldment	05700-000-13-43
4	1	Intake Strainer	05700-000-03-02
5	1	Bulk Head Plug	04730-609-05-00
6	1	Casting, Rinse Feed	05700-000-16-47
7	1	Gasket, Rinse Feed	05330-200-02-06
8	2	Bolt, Flat Head	05305-174-14-00
9	2	Bolt, 5/16"-18 x 1" S/S Hex	05305-275-06-00
10	2	Bolt, 1/4"-20 x 1/2" S/S Hex	05305-274-02-00
11	1	Locknut, 6-32 S/S Hex with Nylon Insert	05310-373-03-00
12	1	Cover, Lundy Probe	05700-000-31-73
13	2	Locknut, 10-24 S/S Hex with Nylon Insert	05310-373-01-00
14	1	Gasket, Lundy Probe Cover	05330-200-25-00
	1	Rinse Arm Assembly	05700-000-28-68
15	1	Rinse Arm	05700-000-28-68
16	2	Rinse Arm Nylon Washer	05311-369-08-00
17	1	Rinse Arm Hex Bushing	05700-000-28-65
18	1	Rinse Arm Snap Ring	05340-112-02-11
19	1	Rinse Feed Pipe Weldment	05700-002-60-96
20	1	Set Screw, 10-24 x 1/2"	05305-473-02-00
21	1	Wash Head Cap	05700-000-10-12
22	57	Ball Bearing, 1/4" S/S	03110-100-03-24
23	1	Threaded Shaft	05700-000-11-01
24	1	Small Manifold Washarm	05700-000-57-69
25	1	Large Manifold Washarm	05700-000-57-70
26	1	Casting, Wash Head Bottom	05700-000-10-36
27	1	Locknut, 1/4"-20 S/S Hex with Nylon Insert	05310-374-01-00
28	1	Bolt, 1/4"-20 x 2 3/4" S/S Hex Head	05305-274-13-00
29	1	Overflow Strainer	04730-017-15-05
30	1	O-ring	05330-400-05-00
31	1	Stem	05305-171-13-00
32	1	Inside Porcelain	05970-604-02-00
33	1	Rubber Insert	05970-604-03-00
34	1	Outside Porcelain	05970-604-04-00
35	1	Washer, #6 Paper	05970-604-01-00
36	2	Nut, 6-32 S/S Hex	05310-271-01-00
37	1	Lockwasher, #6 External Tooth	05311-271-02-00

BOTTOM VIEW ASSEMBLY (10APRB SHOWN FOR REFERENCE)

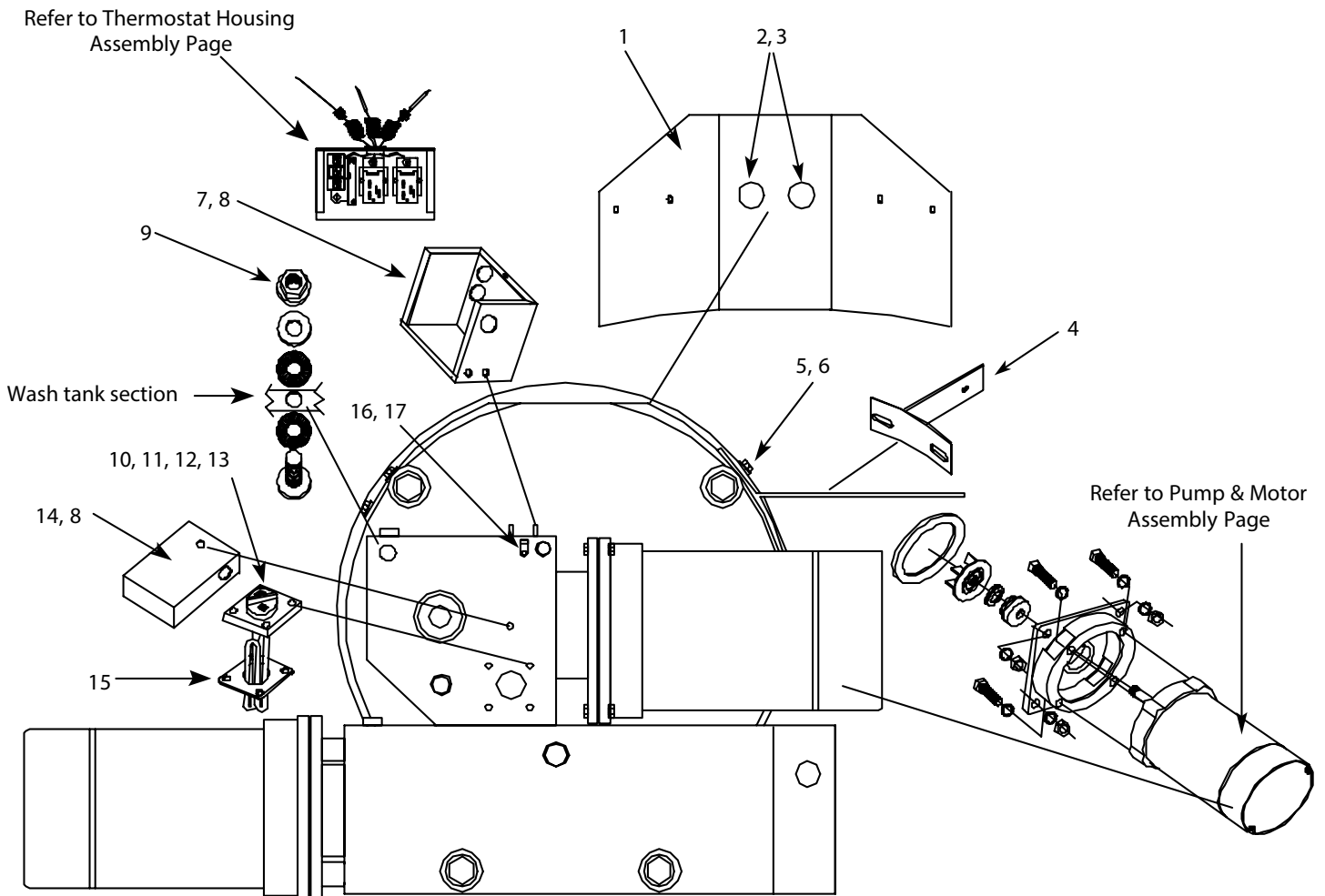
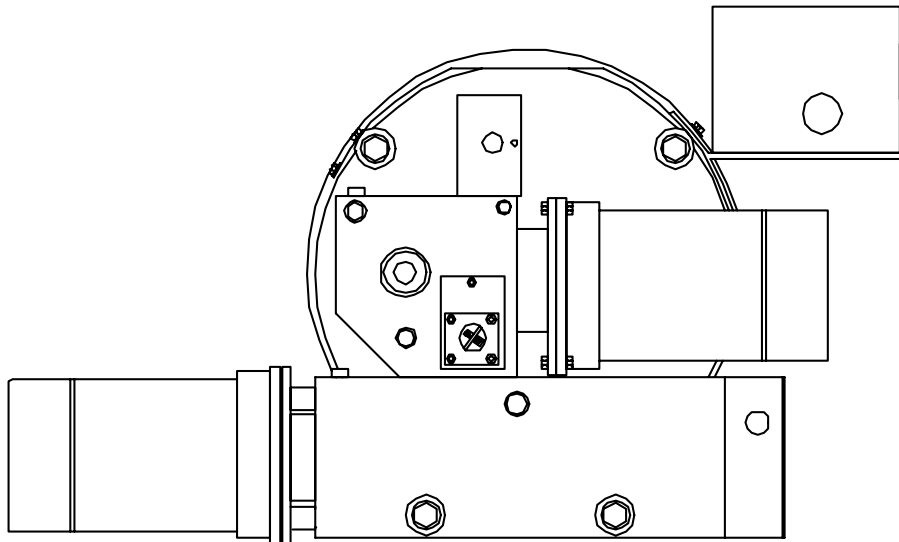

BOTTOM VIEW OF TUB ASSEMBLY

PARTS

BOTTOM VIEW ASSEMBLY (10APRB SHOWN FOR REFERENCE)

ITEM	QTY	DESCRIPTION	Mfg. No.
1	1	Shroud, (Without Holes For Gauges)	05700-000-24-77
	1	Shroud, (With Holes For Gauges)	05700-002-60-36
2	2	Gauge, Temperature	06685-111-68-48
3	1	Decal, Wash and Rinse Temperature	09905-100-43-21
4	1	Control Box Support Bracket	05700-000-24-76
5	4	Bolt, 5/16"-18 x 1" S/S Hex	05305-275-06-00
6	4	Washer, 5/16" S/S Flat	05311-175-01-00
7	1	Thermostat Box Weldment	05700-000-59-70
8	3	Locknut, 1/4"-20 S/S Hex with Nylon Insert	05310-374-01-00
9	1	Bulk Head Plug	04730-609-05-00
10	1	Element, Wash Heater	04540-100-11-10
11	4	Washer, 1/4"-20 S/S	05311-174-01-00
12	4	Lockwasher, 1/4" Spring	05311-274-01-00
13	4	Nut, 1/4"-20 S/S Hex	05310-274-01-00
14	1	Cover, Wash Heater	05700-000-60-57
15	1	Gasket, Wash Heater	05330-100-01-10
16	1	Clamp, 1/8" Nylon	05975-601-10-15
17	1	Locknut, 6-32 S/S Hex with Nylon Insert	05310-373-03-00

WASH TANK CROSS VIEW/TUB TO BOOSTER CONNECTION

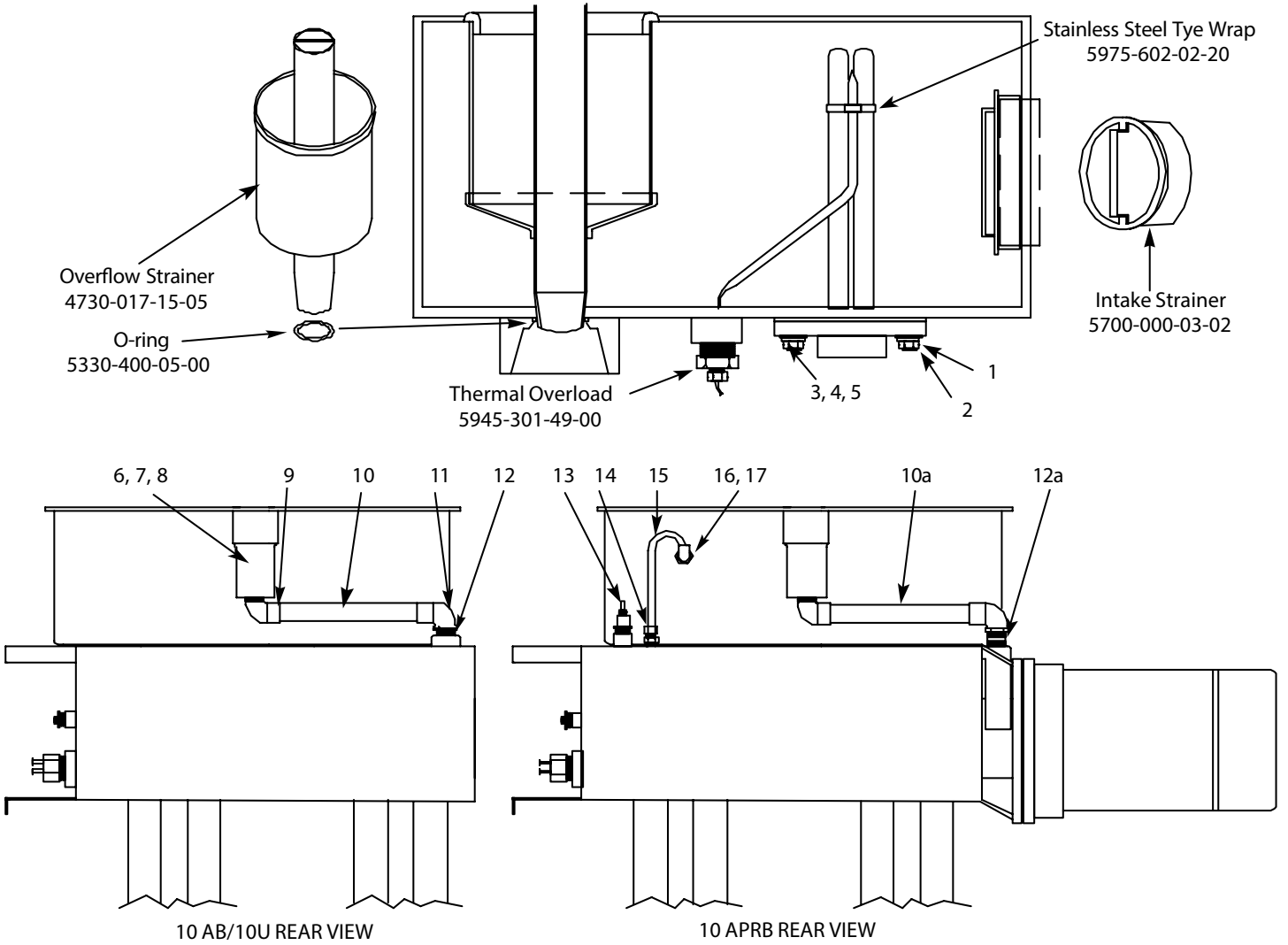

ITEM	QTY	DESCRIPTION	PART NUMBER
1	1	Gasket, Wash Heater	05330-100-01-10
2	1	Element, Wash Heater	04540-100-11-10
3	4	Washer, 1/4"-20 S/S	05311-174-01-00
4	4	Lockwasher, 1/4" Spring	05311-274-01-00
5	4	Nut, 1/4"-20 S/S Hex	05310-274-01-00
6	1	Bracket, Hood Support	05700-000-27-55
7	1	Rivet, 3/16" x 5/8" S/S CTR Flat Head	05320-107-07-00
8	1	Gasket, Hood Support Bracket	05330-200-01-06
9	1	Elbow, 3/4" 90B CU to MNPT Brass	04730-406-42-01
10	1	Tube, 3/4" x 7 1/2" Copper	05700-000-54-86
10a	1	Tube, 3/4" x 6 1/4" Copper (APRB Only)	05700-000-54-87
11	1	Elbow, 3/4" 90B CU to FSPS Brass	04730-406-41-01
12	1	Nipple, 3/4" NPT Close Brass	04730-207-34-00
12a	1	Nipple, 3/4" NPT x 2" Long Brass (APRB Only)	04730-207-46-00
13	1	Probe, High Water (APRB Only)	06680-200-02-68
14	11	Fitting, 1/4" Straight Brass (APRB Only)	04730-011-49-65
15	1	Breather Tube, 1/4" O.D. (APRB Only)	05700-000-29-44
16	1	Elbow, 1/2" 90B CU to FSPS Brass (APRB Only)	04730-406-32-01
17	2	Locknut, Brass 1/2" (APRB Only)	04730-208-03-00

10AB/10APRB/10U MODELS ONLY

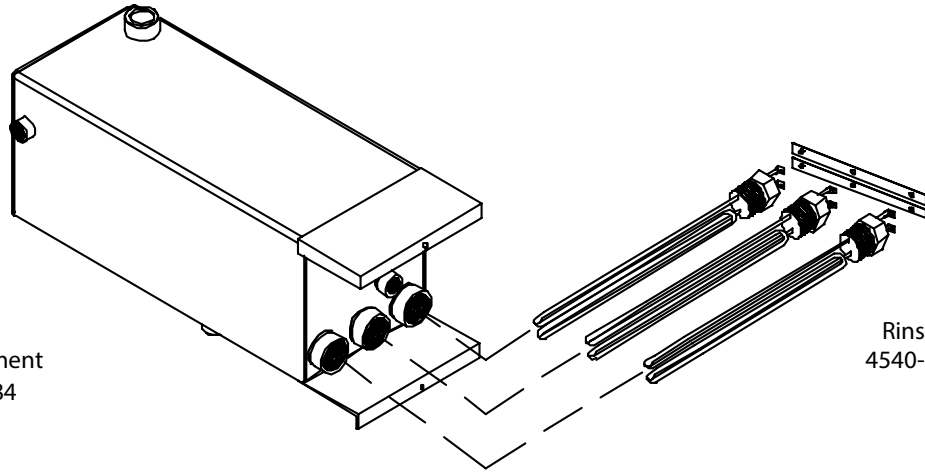

10AB/10U
Rinse Tank Weldment
5700-000-24-84

10APRB
Rinse Tank Weldment
5700-000-24-80

Rinse Heater
4540-100-21-10

Wrapper, Rinse Heater Cover
5700-000-26-40

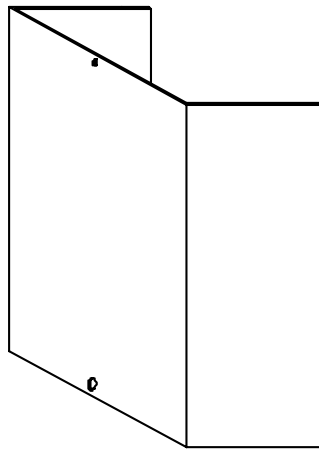

Attaches with 2
Screw, 8-18 x 1/2" Tek Hex
5305-272-01-00

Decal, Warning-Disconnect Power
9905-100-75-93

Booster Tank End View
3 Phase Hookup

Booster Tank End View
1 Phase Hookup

Clamp, 1/8" Nylon
5975-601-10-15
Locknut, 6-32 S/S Hex with
Nylon Insert
5310-373-03-00

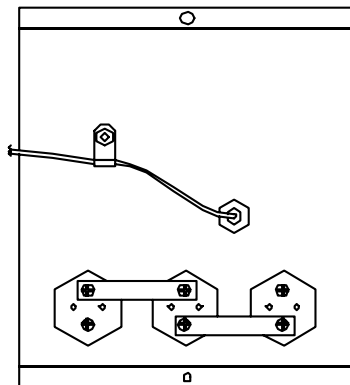

Heater Bus Bar (3 Phase)
5700-000-32-14

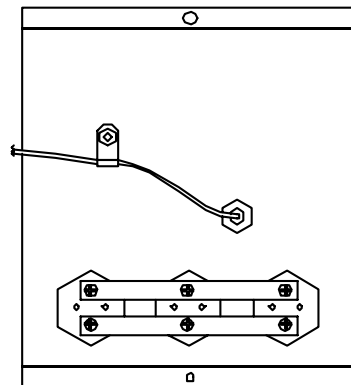

Heater Bus Bar (1 Phase)
5700-000-24-36

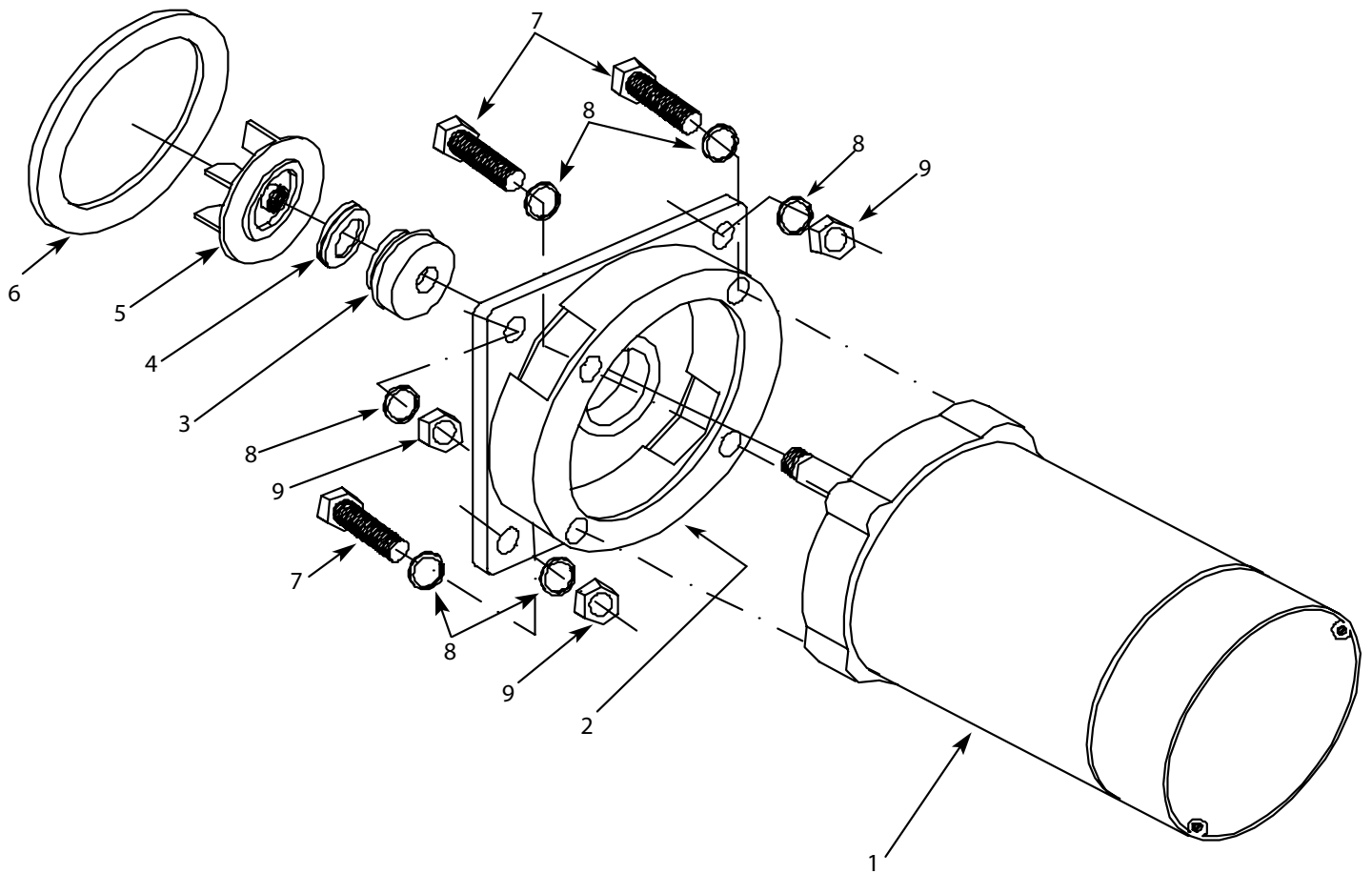

ITEM	QTY	DESCRIPTION	PART NUMBER
	1	Complete Motor and Pump Assembly (2 for APRB units)	05700-002-60-91
1	1	Motor, 115/230 Volt, 1/2 HP, 1 PH, 60 HZ	06105-101-65-00
2	1	Flange, Motor Mounting, Epoxied and Painted	05700-002-60-97
3	1	Seal, Crane	05330-300-09-27
4	1	Seal, Ceramic	05330-300-02-27
5	1	Impeller	05700-000-19-11
6	1	Gasket, Pump	05330-200-34-00
7	4	Screw, 3/8"-16 x 1" Socket Head Cap	05305-356-04-00
8	8	Lockwasher, 3/8" S/S Split	05311-276-01-00
9	4	Nut, 3/8"-16 S/S Hex	05310-276-01-00

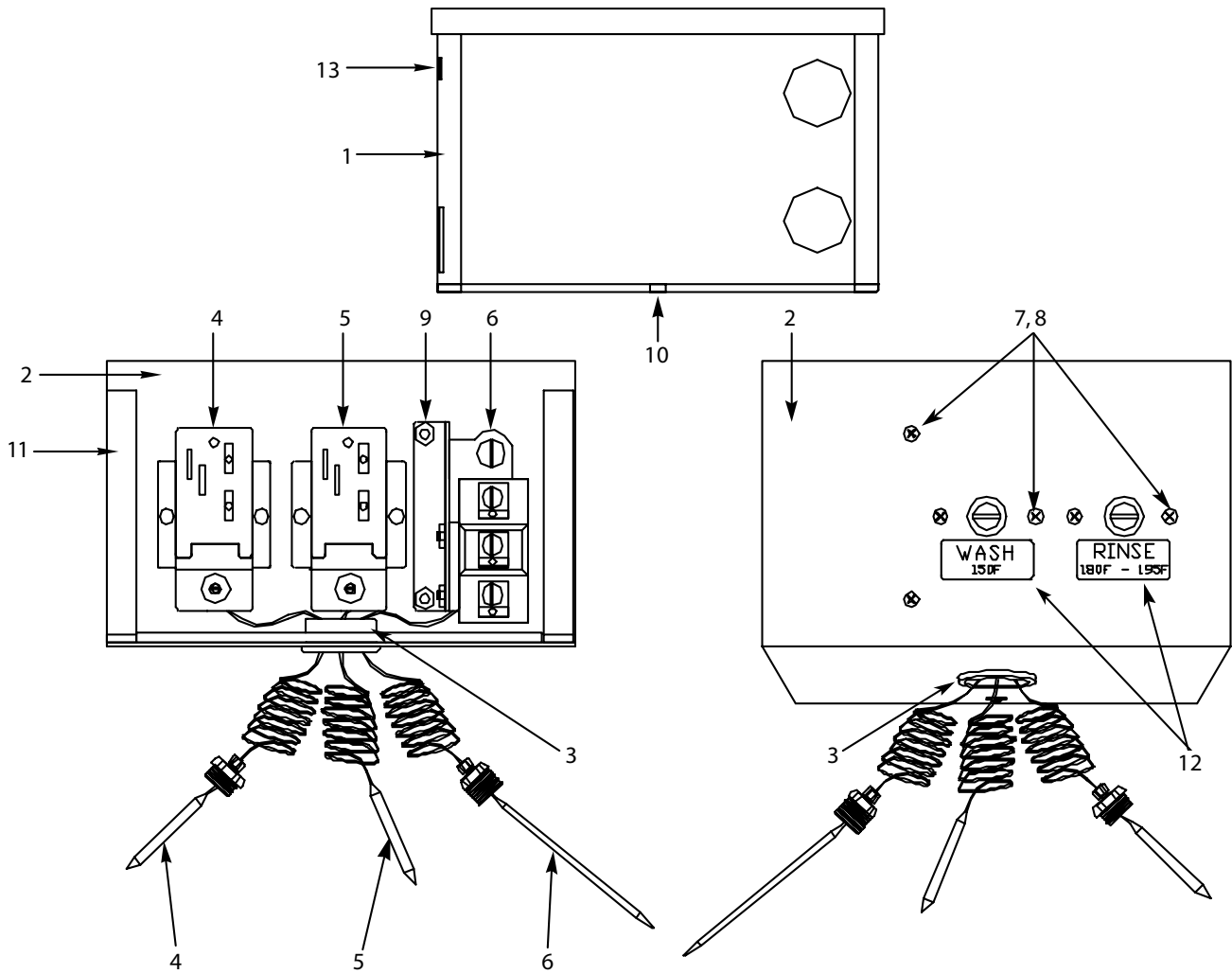

ITEM	QTY	DESCRIPTION	PART NUMBER
1	1	Thermostat Box Weldment	05700-000-59-70
2	1	Front and Bottom, Thermostat Box	05700-001-21-23
3	1	Bushing, Snap in	05975-210-09-00
4	1	Thermostat, Rinse (Not used on 10A)	05930-510-02-00
5	1	Thermostat, Wash	05930-510-01-00
6	1	Overload, Thermal	05945-301-49-00
7	6	Screw, 6-32 x 1/4" S/S Round Head (2 Not used on 10A)	05305-151-02-00
8	4	Lockwasher, #6 External Tooth (2 Not used on 10A)	05311-271-02-00
9	2	Nut, 6-32 S/S Hex	05310-271-01-00
10	1	Screw, 6-32 x 3/8" S/S Round Head	05305-171-02-00
11	18"	Strip, 1/2" x 1/8" Sponge Rubber	05330-100-10-00
12	1	Decals, Wash and Rinse Temperature (Minus Rinse Decal 10A)	09905-100-43-21
13	2	Locknut, 10-24 S/S Hex w/ Nylon Insert	05310-373-01-00

INCOMING PLUMBING ASSEMBLIES

PARTS

10AB/10APRB/10U Incoming Plumbing Assembly
5700-000-15-25

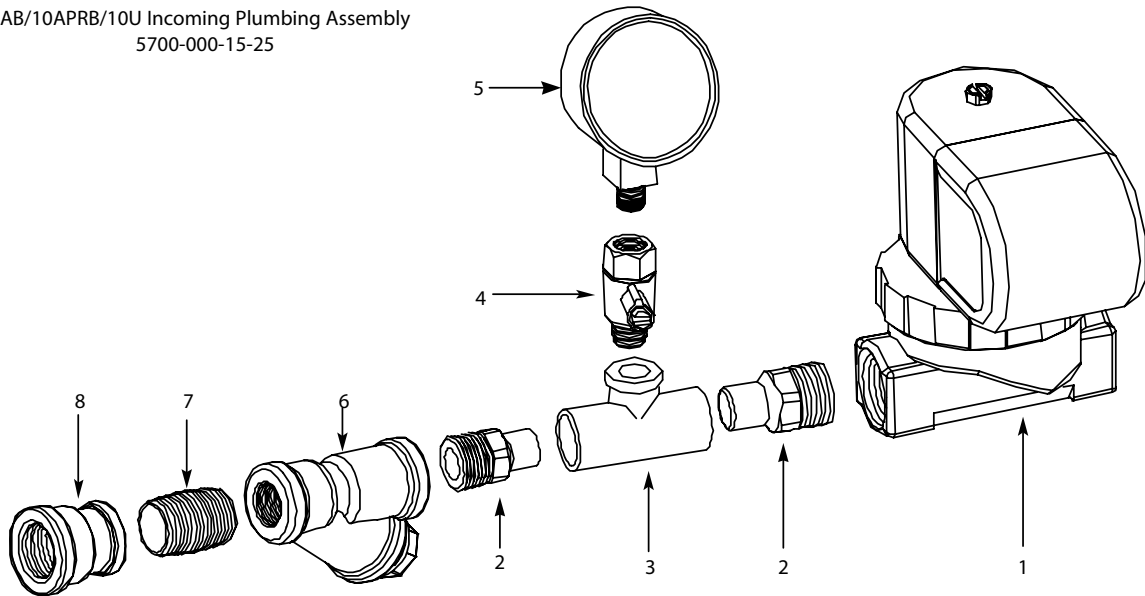

10A Incoming Plumbing Assembly
5700-002-60-98

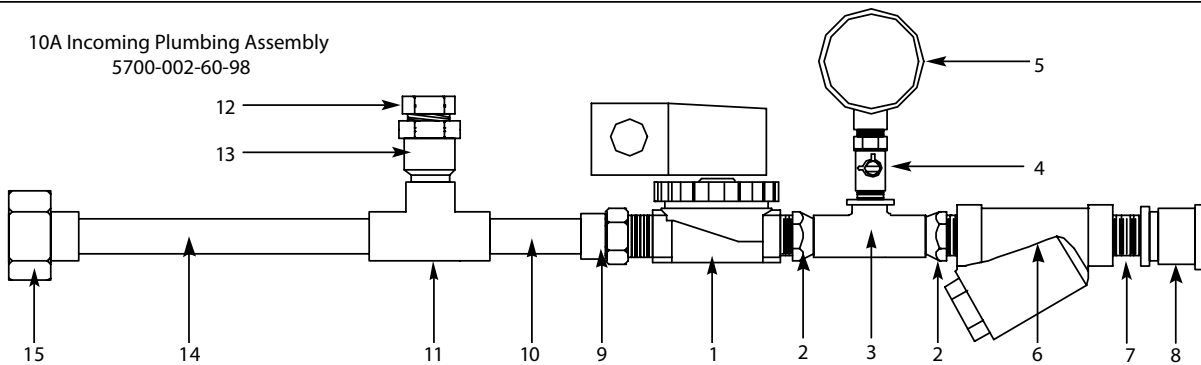

ITEM	QTY	DESCRIPTION	PART NUMBER
1	1	Solenoid Valve, 1/2" 208-240 Volt	04810-100-09-18
2	2	Adapter, 1/2" Fitting x Male	04730-011-59-53
3	1	Tee, 1/2" C x 1/2" C x 1/4" Female Brass	04730-411-25-01
4	1	Ball Valve, 1/4" Test Cock	04810-011-72-67
5	1	Gauge, 0-100 Pressure	06685-111-88-34
6	1	Y-Strainer, 1/2"	04730-217-01-10
7	1	Nipple, 1/2" Close Brass	04730-207-15-00
8	1	Coupling, 1/2" x 3/4" Brass	04730-204-07-00
9	1	Adapter, 1/2" Copper x MSPS	04730-401-03-01
10	1	Tube, 1/2" x 1 1/2" Copper	05700-001-04-68
11	1	Tee, 1/2" C x 1/2" C x 1/2" C, Copper	04730-411-01-01
12	1	Reducer, 1/2" to 3/8" Female Bushing	04730-209-14-00
13	1	Adapter, 1/2" C to FSPS	04730-401-07-01
14	1	Tube, 1/2" x 7" Copper	05700-001-04-67
15	1	Union, 1/2" C to C	04730-412-05-01

1/2" SOLENOID VALVE & 1/2" NPT VACUUM BREAKER REPAIR PARTS KITS

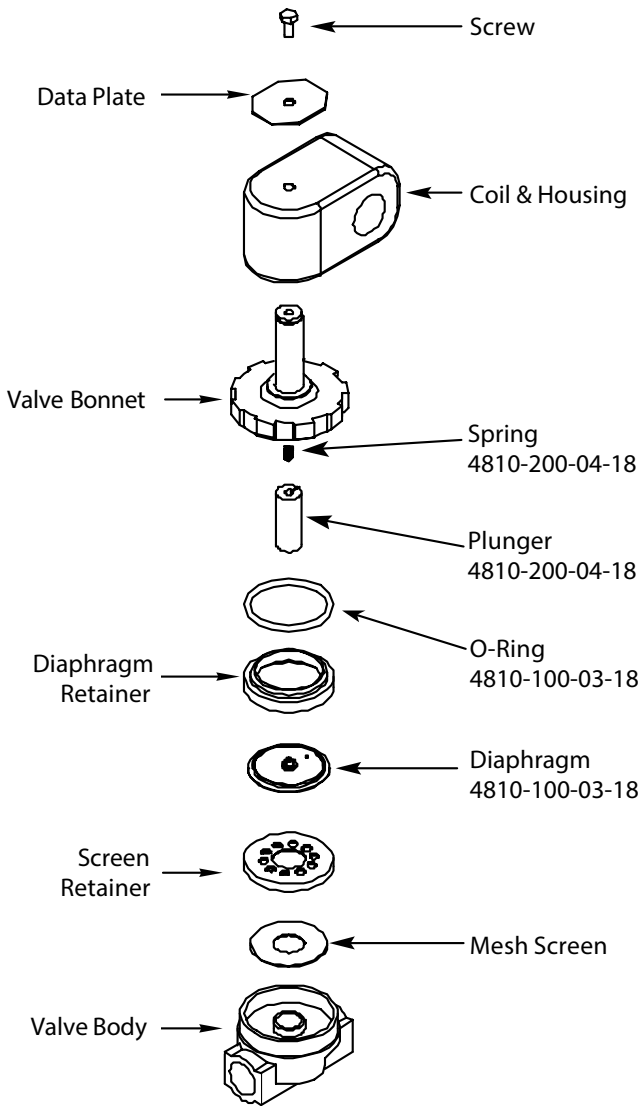

Complete 220 Volt Solenoid Valve Assembly
4810-100-09-18

Coil & Housing only
4810-200-02-18

Diaphragm

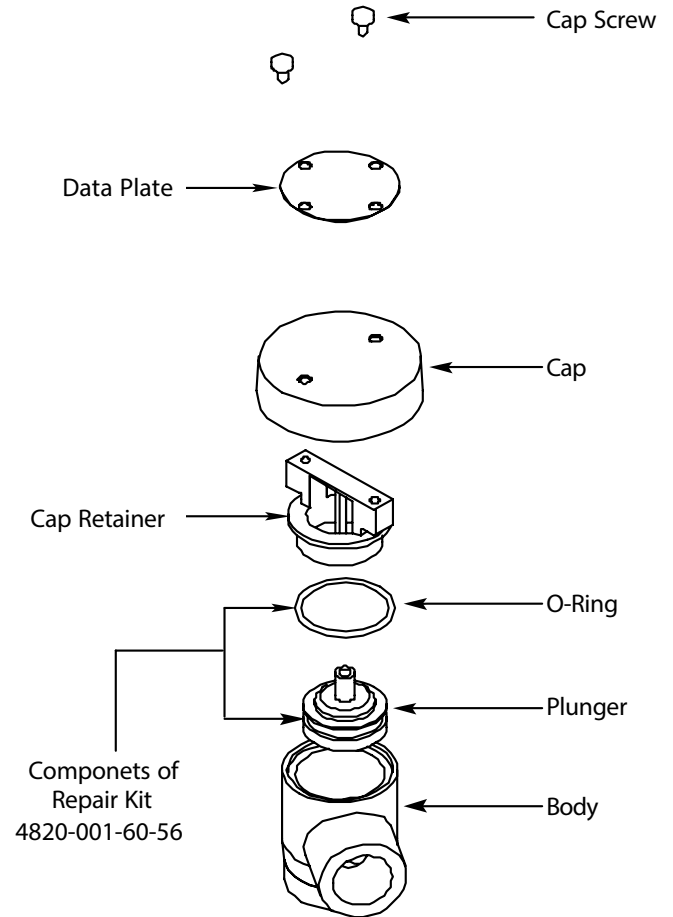
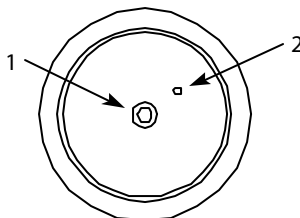

Complete Vacuum Breaker Assembly
4820-300-07-00

TO TAKE THE SOLENOID VALVE APART

DISASSEMBLE - These valves may be taken apart by unscrewing the bonnet and the enclosing tube assembly from the valve body assembly. After unscrewing, carefully lift off the bonnet and enclosing tube assembly. Don't drop the plunger. The o-ring seal and diaphragm cartridge can now be lifted out.

Be careful not to damage the machined faces while the valve is apart.

TO REASSEMBLE - Place the diaphragm cartridge in the body with the pilot port extension UP. Hold the plunger with the synthetic seat against the pilot port. Make sure the o-ring is in place, then lower the bonnet and enclosing tube assembly over the plunger. Screw the bonnet assembly snugly down on the body assembly.

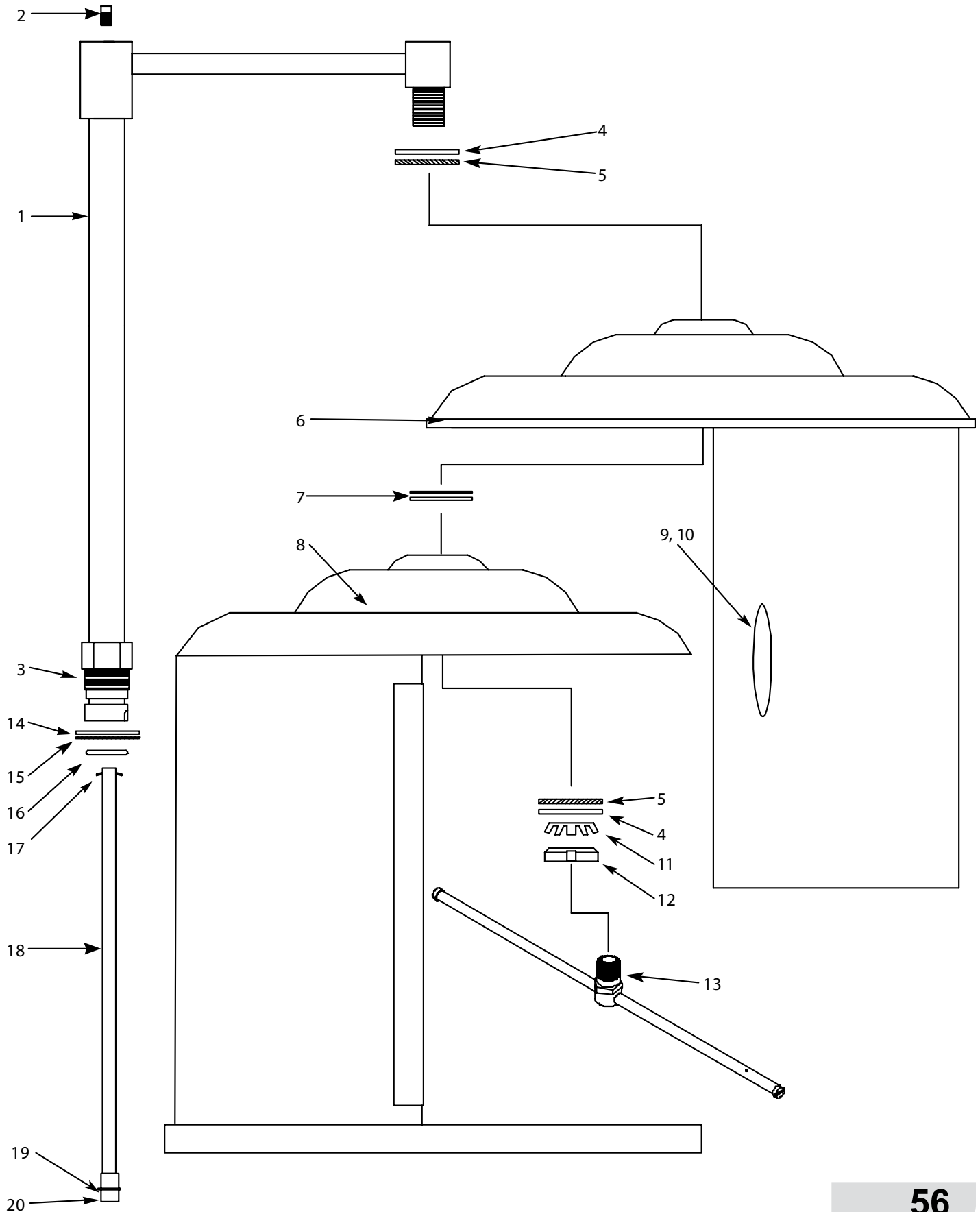

ITEM	QTY	DESCRIPTION	PART NUMBER
1	1	Hood Support, Standard	05700-000-05-57
	1	Hood Support, 4SH/10U	05700-002-60-99
	1	Hood Support, 5HH	05700-000-62-91
2	1	Plug, 1/4" Plated	05700-002-61-00
3	1	Nut, Plated	05700-000-05-52
4	2	Washer, S/S Hood	05311-179-01-00
5	2	Washer, Phenolic	05311-369-02-00
6	1	Door, Outer Weldment, Standard	05700-002-61-01
6	1	Door, Outer Weldment, 4SH/10U	05700-002-61-02
6	1	Door, Outer Weldment, 5HH	05700-002-61-03
7	2	Washer, Teflon	05330-200-11-00
8	1	Door, Inner Weldment, Standard	05700-002-61-04
8	1	Door, Inner Weldment, 4SH/10U	05700-002-61-05
8	1	Door, Inner Weldment, 5HH	05700-002-61-06
9	1	Handle	05700-000-28-30
10	2	Screw, 10-24 x 3/8" Flat Head	05305-773-02-00
11	1	Lockwasher, Spinner	05311-279-02-00
12	1	Locknut, Spinner	05310-379-01-00
13	1	Rinse Head Assembly	05700-000-28-68
15	1	Gasket, 2" O.D. x 1 1/2" I.D. x 1/16"	05330-200-23-00
14	1	Washer	05700-000-29-69
16	2	O-ring	05330-400-03-08
	1	Internal Vacuum Breaker Assembly, Standard	05700-000-24-95
	1	Internal Vacuum Breaker Assembly, 4SH/10U	05700-002-44-78
	1	Internal Vacuum Breaker Assembly, 5HH	05700-002-61-07
17	1	Pin, 1/8"	05700-000-28-92
18	1	Tube, 1/2" x 19 1/2" Copper, Standard	05700-000-28-91
	1	Tube, 1/2" x 15 1/2" Copper, 4SH/10U	05700-002-61-08
	1	Tube, 1/2" x 24 1/2" Copper, 5HH	05700-000-62-92
19	1	Coupling, 1/2" with Groove	05700-011-88-42
20	1	Ring, Retaining	05340-112-01-11
21	1	Decal, Jackson	09905-004-03-02
22	1	Decal, Caution	09905-101-12-28
23	1	Decal, Operating Instructions	09905-101-12-39
24	1	Decal, Clean Strainers & Probe	09905-100-28-42

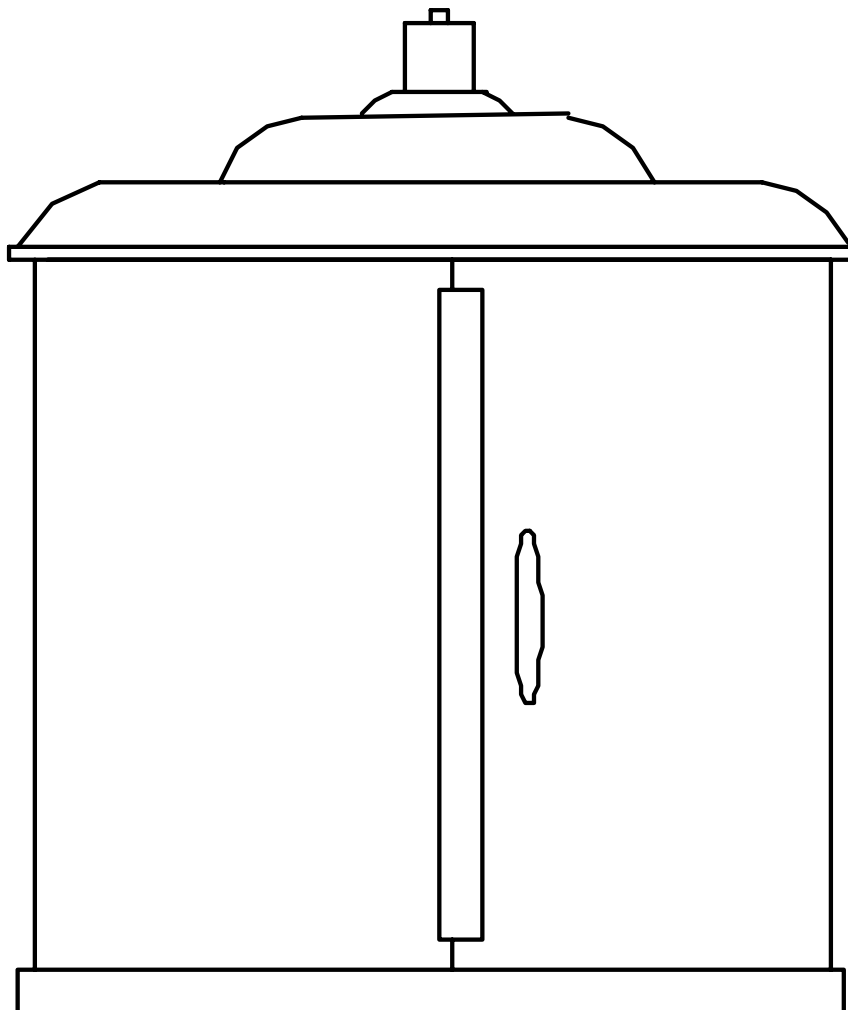

ITEM	QTY	DESCRIPTION	PART NUMBER
1	1	Hood Assembly, Complete Standard	05700-000-25-91
		Hood Assembly, Complete 4"SH/10U	05700-002-17-69
		Hood Assembly, Complete 5"HH	05700-002-61-09

MODEL 10A ASSEMBLIES

Complete Vacuum Breaker Assembly, Standard
5700-002-61-18

Complete Vacuum Breaker Assembly, 4SH
5700-002-44-79

Complete Vacuum Breaker Assembly, 5HH
5700-002-61-66

Plated Outlet Assembly, Standard
5700-002-61-21

Plated Outlet Assembly, 4SH
5700-002-61-69

Plated Outlet Assembly, 5HH
5700-002-61-68

Plated Inlet Assembly, Standard
5700-002-61-20

Plated Inlet Assembly, 4SH
5700-002-61-70

Plated Inlet Assembly, 5HH
5700-002-61-67

Outlet Connector
5700-002-61-19

Adapter, 3/4" CU to MSPS
4730-411-11-01

Bushing, 3/4" to 1/2" Reducer
4730-402-11-01

Copper Tube, 1/2" x 8"
5700-001-04-65

Union, Female Half
5700-002-61-85

Outlet Connector
5700-002-61-19

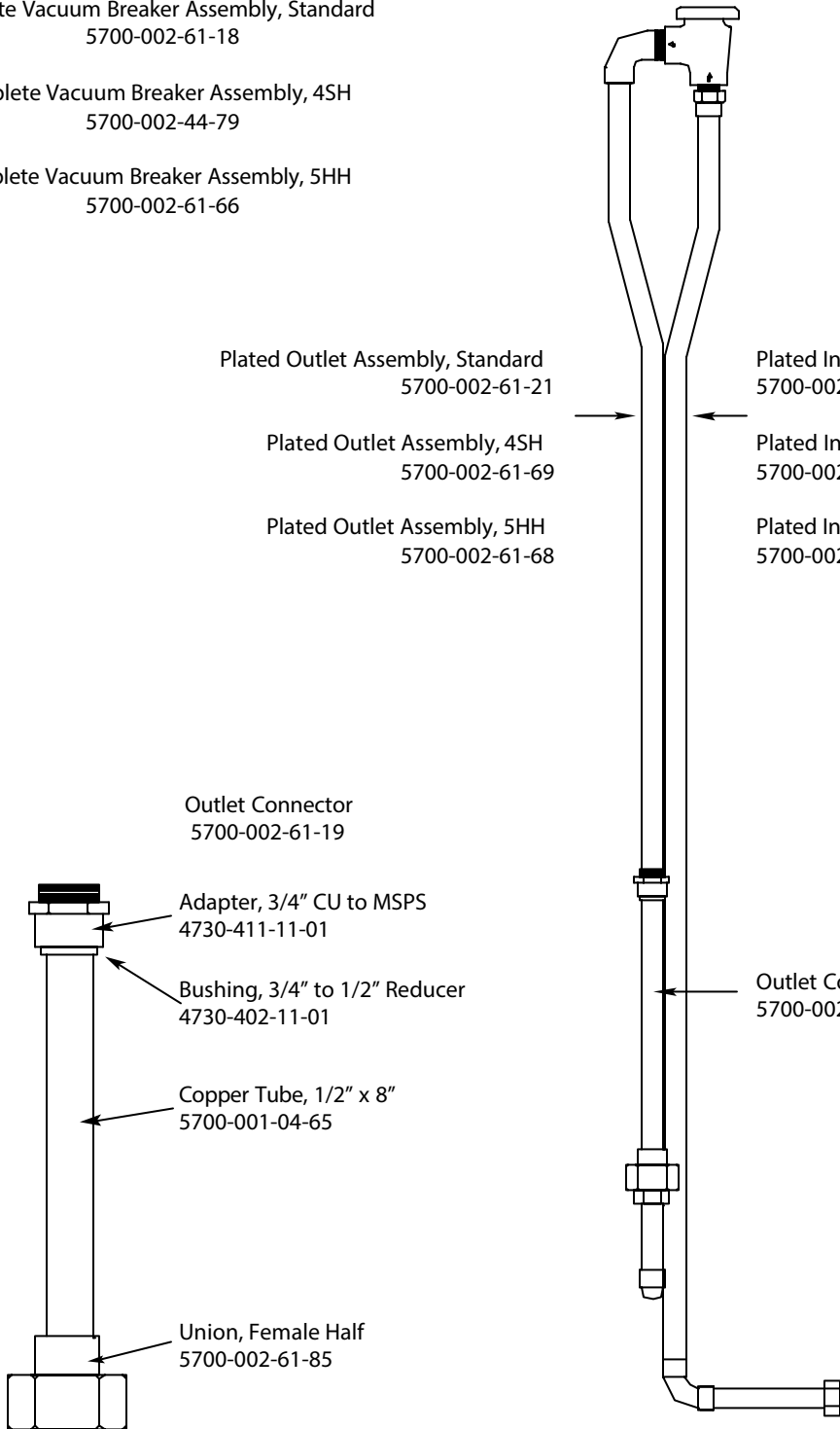

10AB/10APRB/10U ALL UNITS ASSEMBLIES

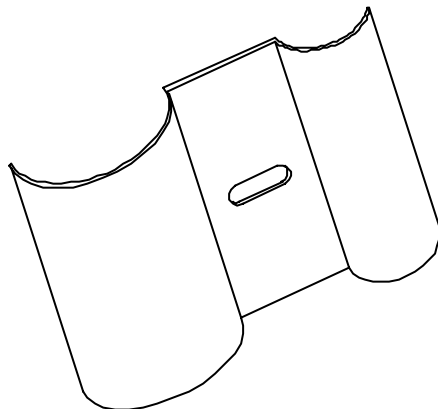
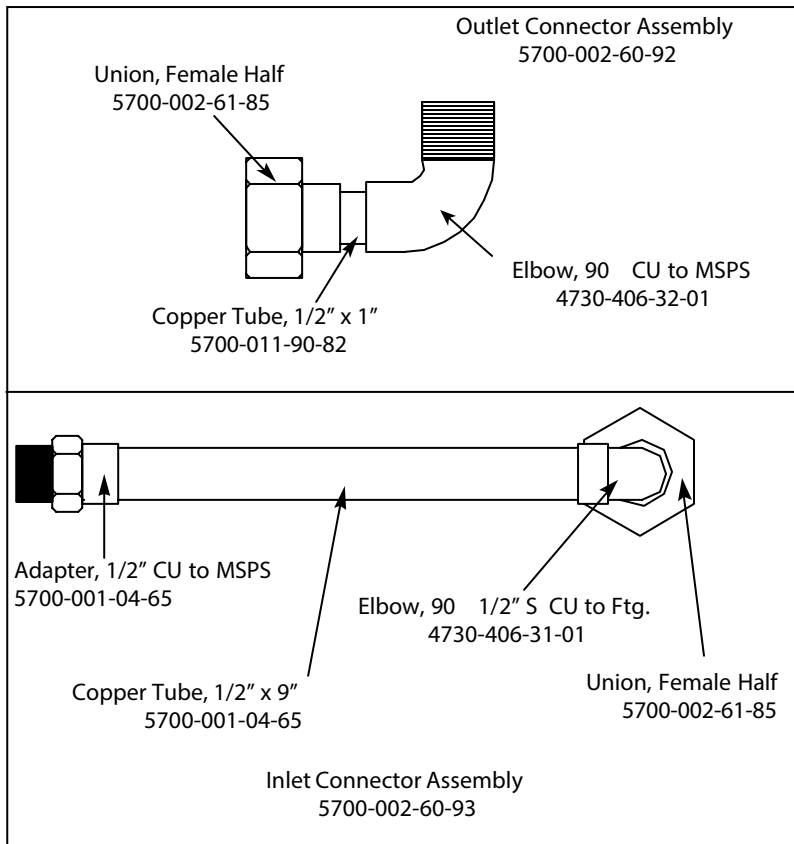

Vacuum Breaker Support Bracket
2 per machine
5700-000-32-27

Secured with:
Bolt, 1/4"-20 x 1/2"
5305-274-02-00

Locknut, 1/4"-20 S/S Hex with Nylon Insert
5310-274-01-00

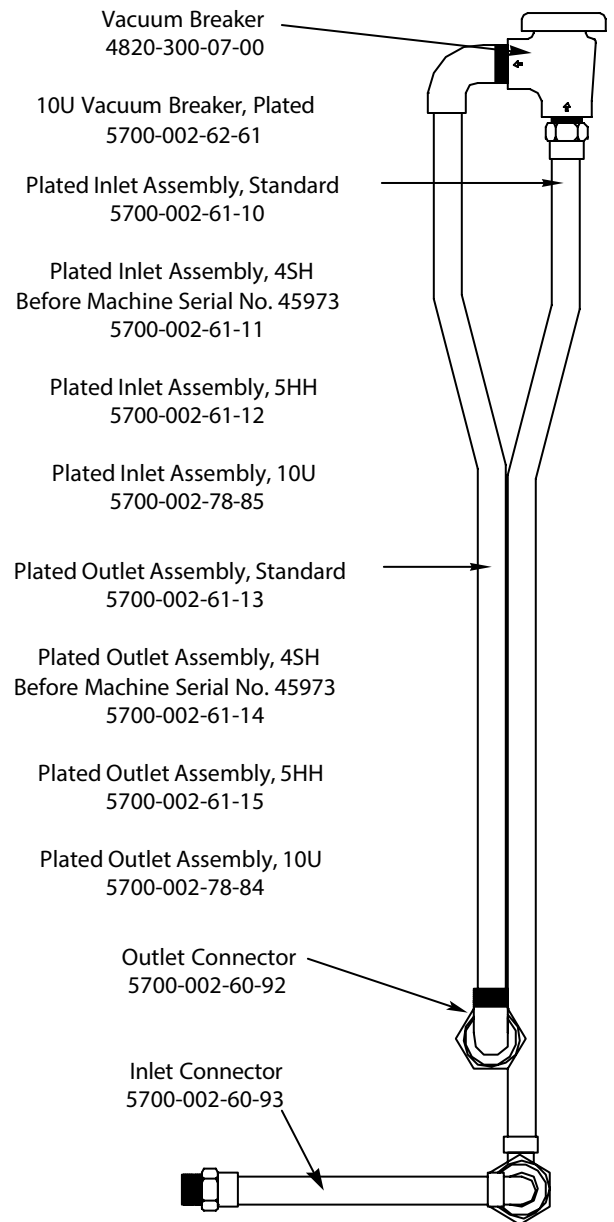

Complete Vacuum Breaker Assembly, Standard
5700-000-32-42

Complete Vacuum Breaker Assembly, 4SH
Before Machine Serial No. 45973
5700-002-61-16

Complete Vacuum Breaker Assembly, 5HH
5700-002-61-17

Complete Vacuum Breaker Assembly, 10U
5700-002-78-86

PART NO.	DESCRIPTION	SERIAL NO.	QTY.
6401-000-54-00	Booster Tank for machine (stripped) AB	AF 28,000	1
6401-000-58-00	Booster Tank for machine (stripped) APRB	AF 28,000	1
5925-105-10-01	Circuit Breaker, 15 amp (specify number from part)	Specify	1
0016300	Control Box, Complete Wired A	AF 28,000	1
5700-000-63-07	Control Box, Complete Wired AB	AF 28,000	1
0016900	Control Box, Complete Wired APR	AF 28,000	1
6401-001-72-00	Control Box, Complete Wired APRB	AF 28,000	1
5700-000-27-99	Control Box, (stripped) only	AF 24,451	1
5700-000-57-45	Control Box, Front Panel Wired A	AF 28,000	1
5700-000-57-45	Control Box, Front Panel Wired AB	AF 28,000	1
0024800	Control Box, Front Panel Wired APR	AF28,000	1
6401-002-51-00	Control Box, Front Panel Wired APRB	AF 28,800	1
5700-000-24-76	Control Box Bracket (only)	All	1
9905-500-07-10	Control Box Front Panel Blank	All	1
5700-000-24-30	Control Box Lower Front Cover (only)	AF 23,294	1
5330-400-05-00	Drain O-Ring	AF 28,000	1
6401-100-11-00	Heater Element, immersion, flange type, w/gasket, 220V, 750W	AF 28,000	1w
5330-100-01-10	Heater Gasket, immersion element, flange type, above	All	1
5120-300-01-03	Heater socket only, for heater element removal, screw plug type	Tool	1
5700-000-24-36	Heater Bus Bars, 3 hole	All	2
4540-100-04-10	Heater Element, 115V, 1500W, Screw in		
5700-000-32-14	Heater Bus Bars, 2 hole	All	2
5700-000-26-40	Heater Box Front/Bottom Cover	AF24,451	1
4540-100-21-10	Heater Element, immersion, screw plug type, 208-230V, 2500W	All	3
5700-000-28-34	Hood Assembly, Standard Complete (includes hood support pipe; coarse thread, and upper rinse, internal vacuum pipe)	AF 21,086	1
6401-006-35-00	Hood Assembly, 5" Taller Complete (includes hood support pipe; coarse thread, and upper rinse, internal vacuum pipe)	Special	1
6401-006-40-00	Hood Only, Standard	AF 17,590	1
6401-006-50-00	Hood Only, 5" Higher	Special	1
5311-179-01-00	Hood Washer, S/S		
5311-369-02-00	Hood Washer, Fiber	All	2
5330-200-11-00	Hood Washer, Teflon	All	2
5310-379-01-00	Hood Spanner Locknut	All	1
5311-279-02-00	Hood Spanner Lockwasher	All	1
5120-100-01-01	Hood Spanner Nut Wrench Tool	All	1
6401-005-10-00	zw/gaskets and screws	All	1
6401-006-84-00	Hood Support Pipe Assembly, Standard, Coarse Thread	AF 21,086	1
6401-006-95-00	Hood Support Pipe Assembly, 5" Higher, (Specify Thread on nut)	All	1
5700-000-27-55	Hood Support Block, Brass, Coarse Thread	AF 21,086	1
5330-200-01-06	Hood Support Block Gasket, Rectangular	All	1
5700-000-05-52	Hood Support Pipe Hex Nut only (coarse thread)	AF 21,086	1
5120-800-01-04	Hood Support Nut Wrench	All	1
5700-000-29-69	Hood Support Pipe Metal Washer	All	1
5330-200-23-00	Hood Support Pipe Rubber Washer	All	1
5330-400-03-08	Hood Support Pipe O-ring	All	1
6401-007-40-00	Hood, Internal Vacuum Breaker Pipe, Standard	AF 24,451	1
6401-007-50-00	Hood, Internal Vacuum Breaker Pipe, 5" Higher	Special	1
5945-504-02-18	Light Indicator, Heater Overload	AF 23,294	2
6401-008-43-00	Probe, Lundy	AF 28,000	1w

PARTS LIST FOR MODEL 10 DISHWASHERS

PARTS

PART NO.	DESCRIPTION	SERIAL NO.	QTY
6680-200-02-68	Probe, Large Hi-Level (APRB only)	All	1r
6680-200-05-68	Rubber Cover (for Hi-level probe) (APRB only)	All	1r
6401-008-50-00	Pump Assembly, Complete w/Motor, 1/2 HP,	AF 24,451	1x
6105-101-65-00	Pump Motor, 115-230V, 1/2 HP, 3450RPM, jet	AF 24,451	1x
5330-300-09-27	Pump Seal (for pump parts 850-863-920-925)	All	1x
6401-008-80-00	Pump Mounting Plate (for pump parts 850-863)	AF 24,451	1x
5330-300-02-27	Pump Ceramic Face w/Retainer Cup (for pump parts 850-863-920-925)	All	1x
5700-000-19-11	Pump Impeller 2 3/4" Dia. 7/16" Tap (for pump parts 850-863)	AF 24,451	1w
5330-200-34-00	Pump Gasket (for pump parts 850-863)(mounting)	AF 24,451	1r
5305-256-03-00	Pump Bolts (for pump parts 850-863)	AF 24,451	
5305-256-03-00	Pump Bolts (for pump parts 850-863)	BF 24,451	4r
5311-256-01-00	Pump Lockwashers (for pump parts 850-863-920-925)	All	4x
5310-256-01-00	Pump Hex Nuts (for pump parts 850-863-920-925)	All	4x
5700-000-13-43	Rack Support Rod Assembly	All	1
7320-100-13-01	Rack, Open Type, (cup, bowl & glass) moulded	Model 10 (JO)	
7320-100-09-01	Rack, Peg Type, (plate) moulded	Model 10 (JP)	
7320-100-17-01	Rack, Compartment Type, (glass), moulded	Model 10 (JO-3)	
7320-100-08-01	Rack, Four-Compartment Basket (silverware) moulded	All Models (J4)	
7320-100-14-01	Rack, Eight-Compartment Basket (silverware) moulded	All Models (P4C8)	
7320-100-05-01	Rack, Twelve-Compartment Basket (silverware) moulded	All Models (P4C12)	
6400-000-90-24	Rack, Square Moulded w/Stainless "H" bar (for 20" x 20" sinks), dishtables	-	
4820-100-04-07	Regulator, Pressure, 1/2" Watts	All	1
4820-200-01-06	Regulator, Repair Kit, Pressure, 1/2" Watts	All	1
5945-109-03-69	Relay, 220V, 2-Pole, HW (used on wash heat circuit)	-	-
5945-109-02-69	Relay, 220V, 2-Pole, HW (used on rinse heat circuit, single-phase)	AF 24,451	1
5945-109-06-69	Relay, 220V, 2-Pole, HW (used on rinse heat circuit, three-phase)	AF 24,451	1
5700-000-28-68	Rinse Head Assembly, upper and lower interchange, 13 1/2" Long	All	1x
5700-000-28-65	Rinse Head Hex Bushing	AF 22,734	2
5311-369-08-00	Rinse Head Nylon Washer	AF 22,734	4
5340-112-02-11	Rinse Head Snap Ring S/S	AF 22,734	2
6400-000-61-52	Rinse Head Laminated Washer	BF 22,734	4
6401-013-00-00	Rinse Head Lower Feed Pipe	All	1
5330-200-02-06	Rinse Head Oval Gasket (for 1300)	All	1
7920-100-02-00	Rinse Head Brush, Tube Cleaning	All	1
7320-500-01-04	Scrap Block (for tables)	All	1
4810-100-12-18	Solenoid Valve, 1/2", 110V, JE	AF 18,000	1
4810-100-09-18	Solenoid Valve, 1/2", 220V, JE	AF 18,000	1
4810-200-01-18	Solenoid Valve Coil, 1/2", 110V, JE	AF 18,000	1
4810-200-02-18	Solenoid Valve Coil, 1/2", 220V, JE	AF 18,000	1
4810-200-03-18	Solenoid Valve Diaphragm Cartridge & O-ring, 1/2", JE	AF 18,000	1
4810-200-05-18	Solenoid Valve O-ring, 1/2", JE	AF 18,000	1
4810-200-04-18	Solenoid Valve Plunger Assembly, 1/2", JE	AF 18,000	1
4810-200-07-18	Solenoid Valve Strainer Screen, 1/2", JE	AF 18,000	1
4730-017-15-05	Strainer, Large Overflow	All	1
4730-017-15-10	Strainer, Small Pump Intake	All	1
4730-217-01-10	Strainer, "Y", 1/2"	All	1
5930-301-20-18	Switch, Rinse/Fill (all) (SPDT) momentary slip disconnect	AF 24,451	1
5930-301-21-18	Switch, Manual Wash (DPDT) slip disconnect	AF 24,451	1
5930-301-22-18	Switch, Master (DPST) (all) slip disconnect (used on wash heat and conveyor on 39's)	AF 24,451	1

PART NO.	DESCRIPTION	SERIAL NO.	QTY.
5930-301-22-18	Switch, Heat (DPST) (all) slip disconnect	AF 24,451	1
5930-301-23-18	Switch, Start (SPDT) (all) slip disconnect	AF 24,451	1
6401-016-55-00	Terminal Board, 3-Pole, complete (three-phase)	All	1
5940-500-06-19	Terminal Board, 9-Pole, complete slip terminal	AF 24,451	1
6685-200-01-10	Thermometer, Wash or Rinse, Standard	All	1
5700-000-57-25	Thermostat Box, Complete, Without Wash Heater Overload	AF 28,000	1
5930-510-02-00	Thermostat, Rinse	All	1
5930-510-01-00	Thermostat, Wash	All	1
5945-303-18-00	Timer, 115V with Wires and Mounting Plate	All	1
5945-303-19-00	Timer, 220V with Wires and Mounting Plate	All	1
5945-306-05-00	Timer Motor, 115V (for Module-type Timer)	All	1
5945-306-06-00	Timer Motor, 220V (for Module-type Timer)	All	1
5945-306-02-00	Timer Micro Switches, Plastic Module-type (for Eagle Bliss)	All	3
4820-300-07-00	Vacuum Breaker, 1/2",	AF 35,373	1
4820-200-22-00	Vacuum Breaker Repair Kit	-	-
4820-200-02-30	Vacuum Breaker Poppet	AF 28,000	1
4810-100-03-00	Valve, 1/4"	All	1
6401-018-60-00	Wash Head Assembly Complete	AF 19,035	1
5700-000-10-12	Wash Head Cap w/Race	AF 19,035	1
5305-473-02-00	Wash Head Cap Set Screw	AF 19,035	1
5700-000-11-01	Wash Head Center Shaft	AF 19,035	1
5305-274-13-00	Wash Head Holding Bolt	AF 19,035	1
5310-374-01-00	Wash Head Nut for Holding Bolt	AF 19,035	1
5700-000-57-69	Wash Head Small Manifold Assembly	AF 10,282	1
5700-000-57-70	Wash Head Large Manifold Assembly	AF 10,282	1
5700-000-10-36	Wash Head Fixed Race	AF 10,282	1
6401-100-03-24	Wash Head 1/4" S/S Ball Bearings, 25 qty. each package	All	57
6680-200-02-19	Water Level Control, 110V	AF 23,344	1
6680-200-01-19	Water Level Control, 220V	AF 23,344	1
5945-305-01-19	Water Level Control, Relay Only	AF 23,344	1
6680-200-01-19	Water Level Control, Printed Board Only	AF 23,344	1
5945-301-49-00	Overload, Hi-limit, for Wash Heater	-	-
5975-602-02-20	Tie Strap, Stainless Steel	-	-

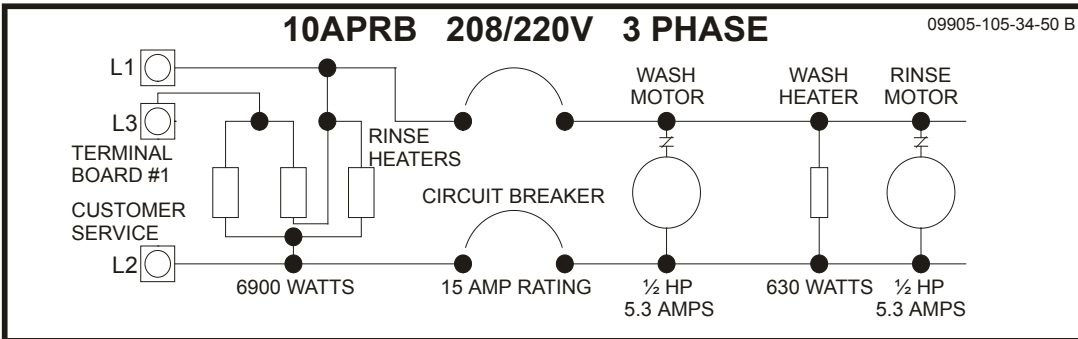
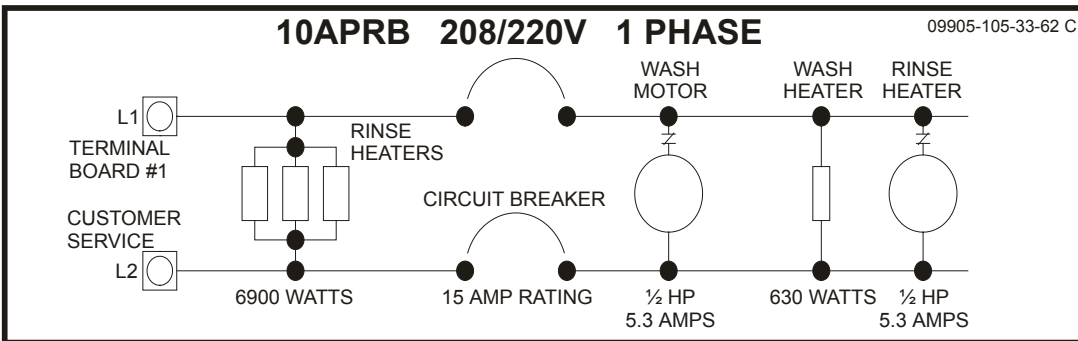
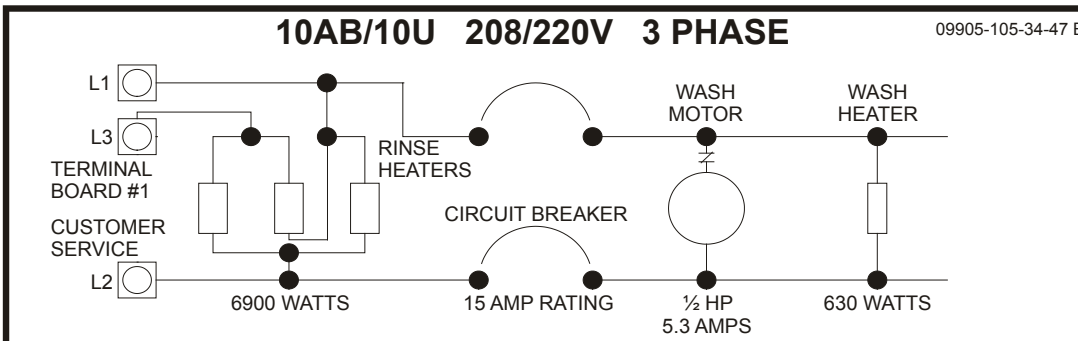
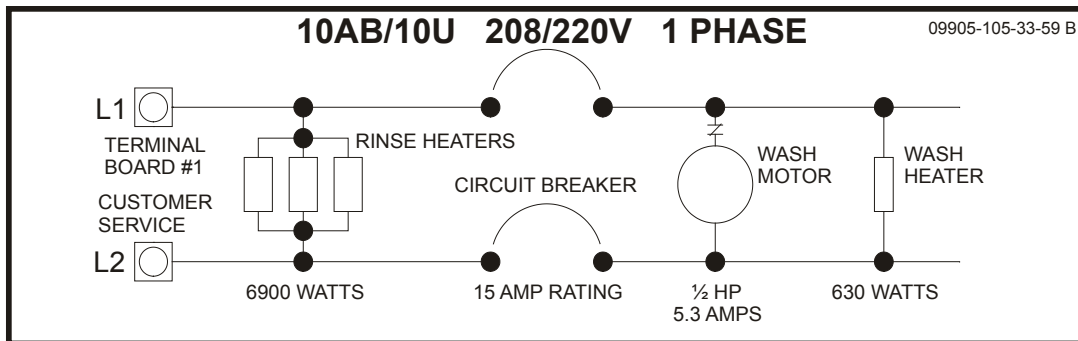
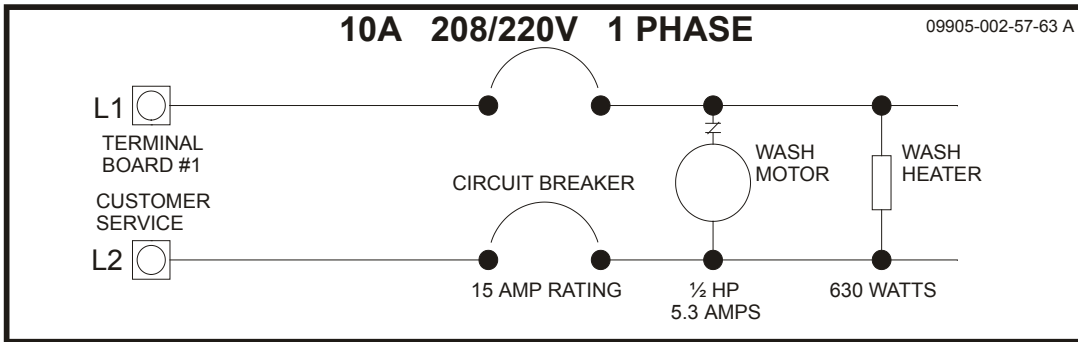

10A WIRING DIAGRAM (208-230 VOLT, 60HZ, SINGLE PHASE)

LEGEND

- GND GROUND
- CB-1 CIRCUIT BREAKER
- M-SW MASTER SWITCH
- H-SW HEATER SWITCH
- W-THS WASH THERMOSTAT
- ELS WATER LEVEL CONTROL
- TH CYCLE CAM
- TW WASH CAM
- TR RINSE CAM
- R CYCLE LIGHT
- TM TIMER MOTOR
- S-SW CYCLE SWITCH
- MW-SW MANUAL WASH SWITCH
- SOL FILL SOLENOID

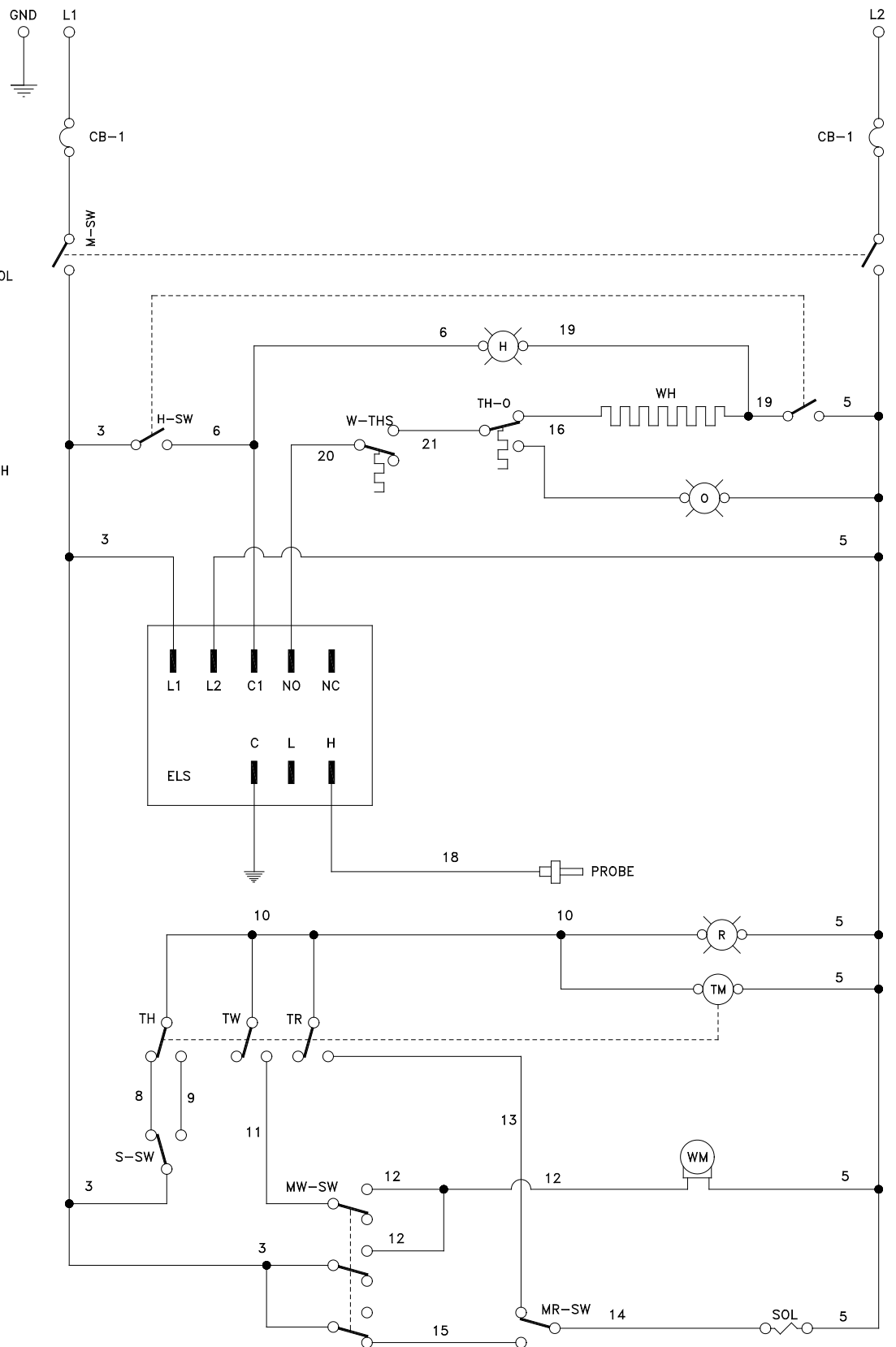

10AB WIRING DIAGRAM

SCHEMATICS

10AB WIRING DIAGRAM (208-230 VOLT, 60HZ, SINGLE PHASE)

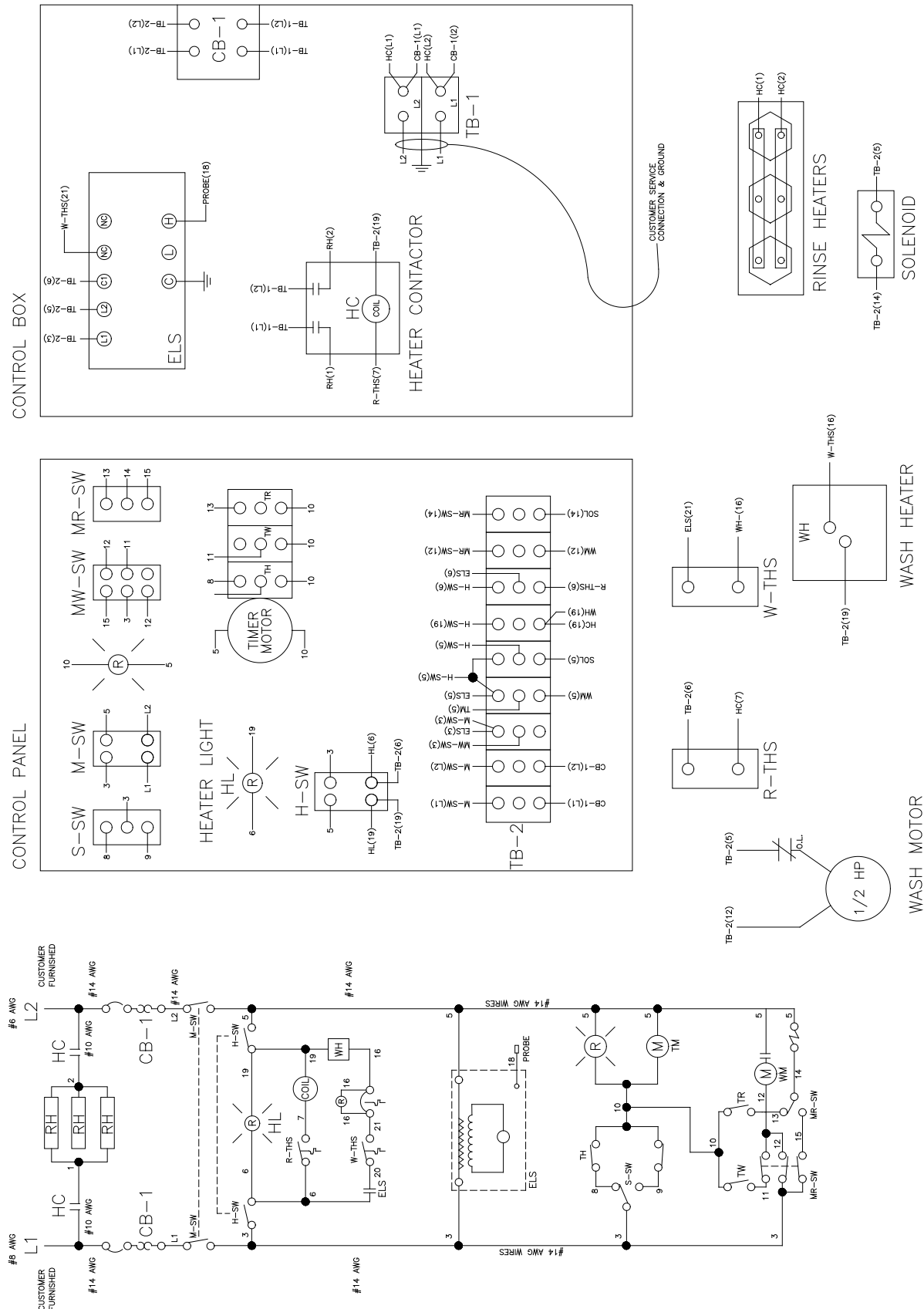

10AB WIRING DIAGRAM (208-230 VOLT, 60HZ, THREE PHASE)

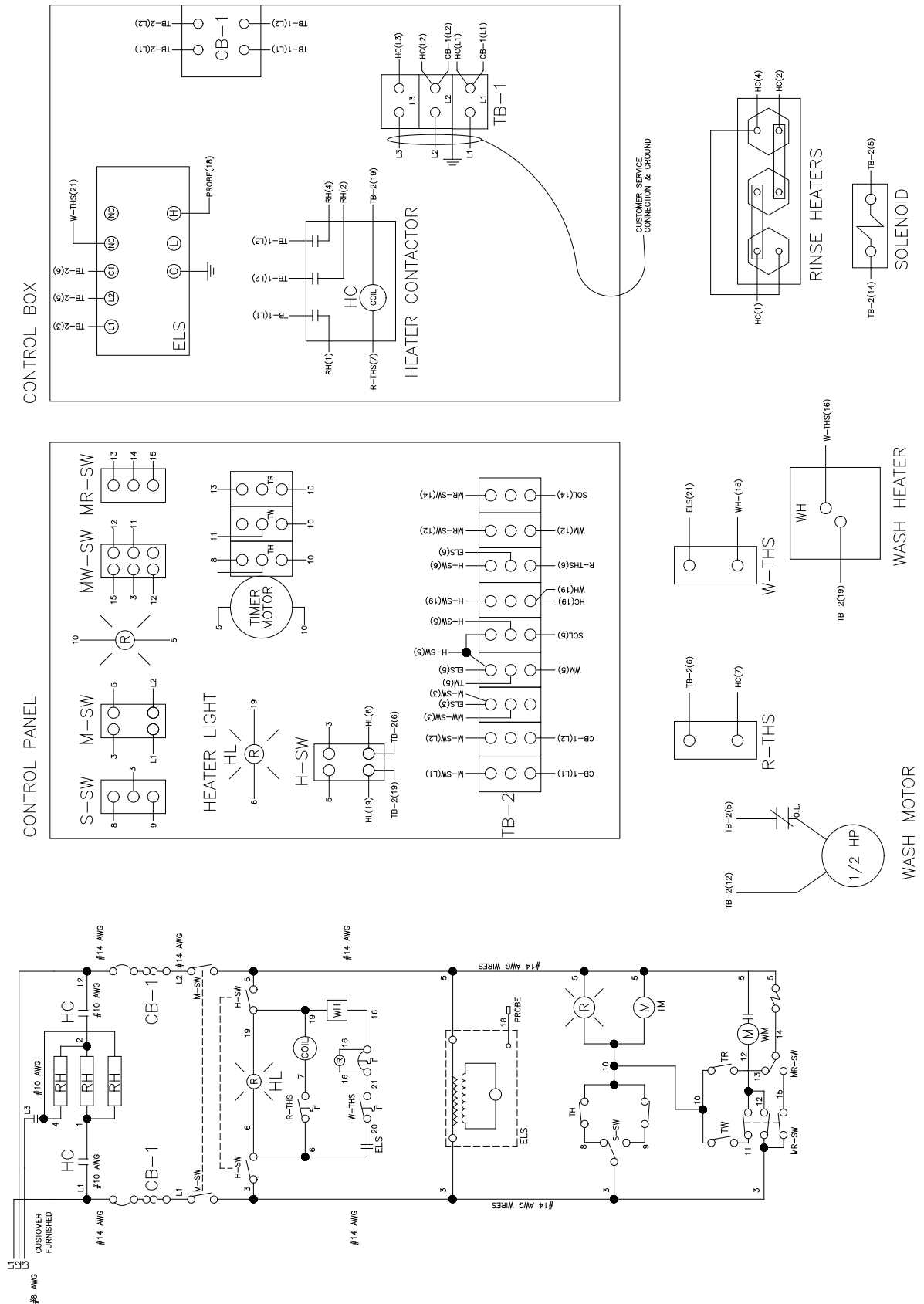

CONTROL BOX

CONTROL PANEL

HEATER CONTACTOR

RINSE HEATERS

SOLENOID

WASH HEATER

WASH MOTOR

CUSTOMER SERVICE CONNECTION & GROUND

10APRB WIRING DIAGRAM

SCHEMATICS

10APRB WIRING DIAGRAM (208-230 VOLT, 60HZ, SINGLE PHASE)

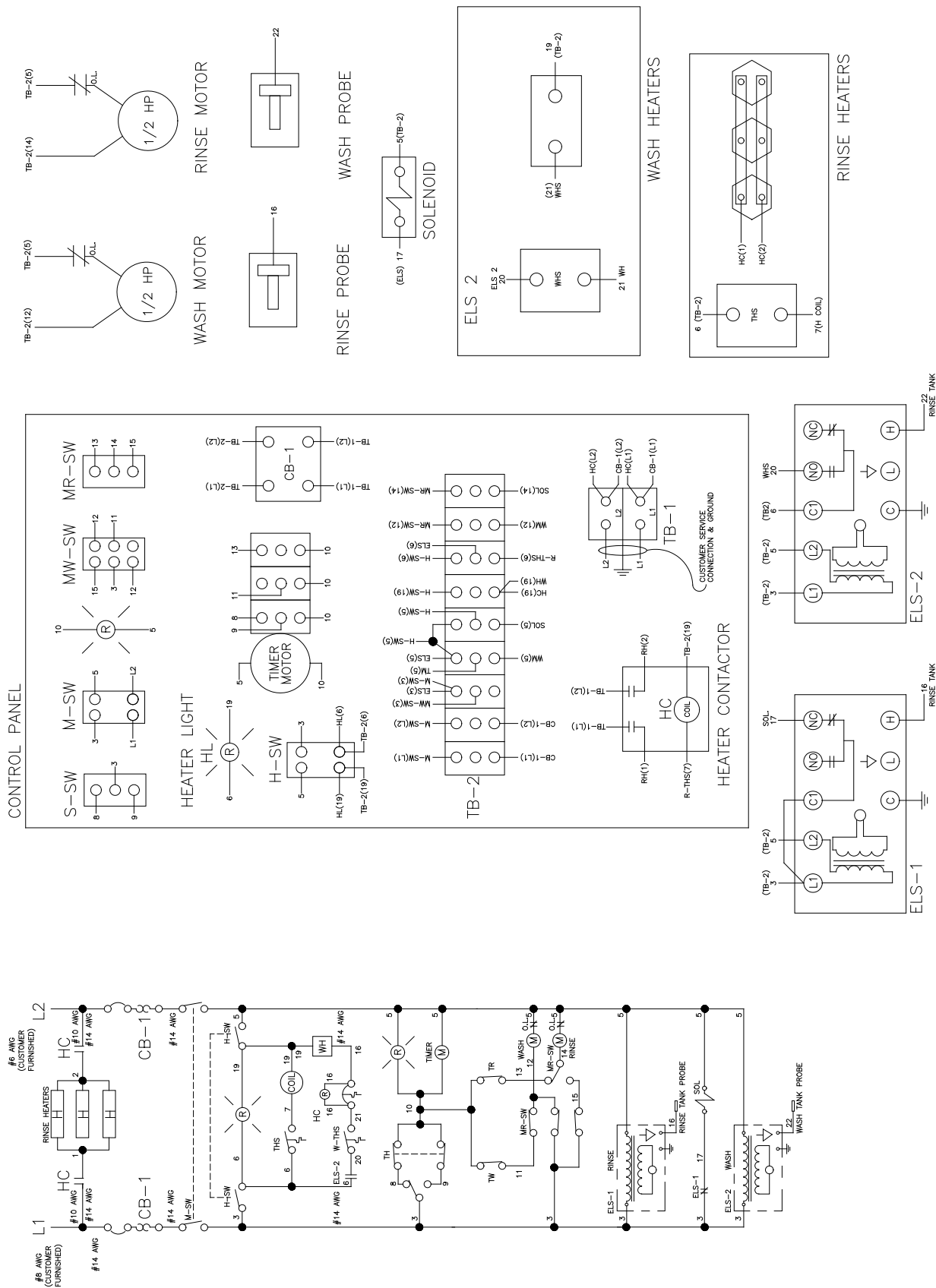

10APRB WIRING DIAGRAM (208-230 VOLT, 60HZ, THREE PHASE)

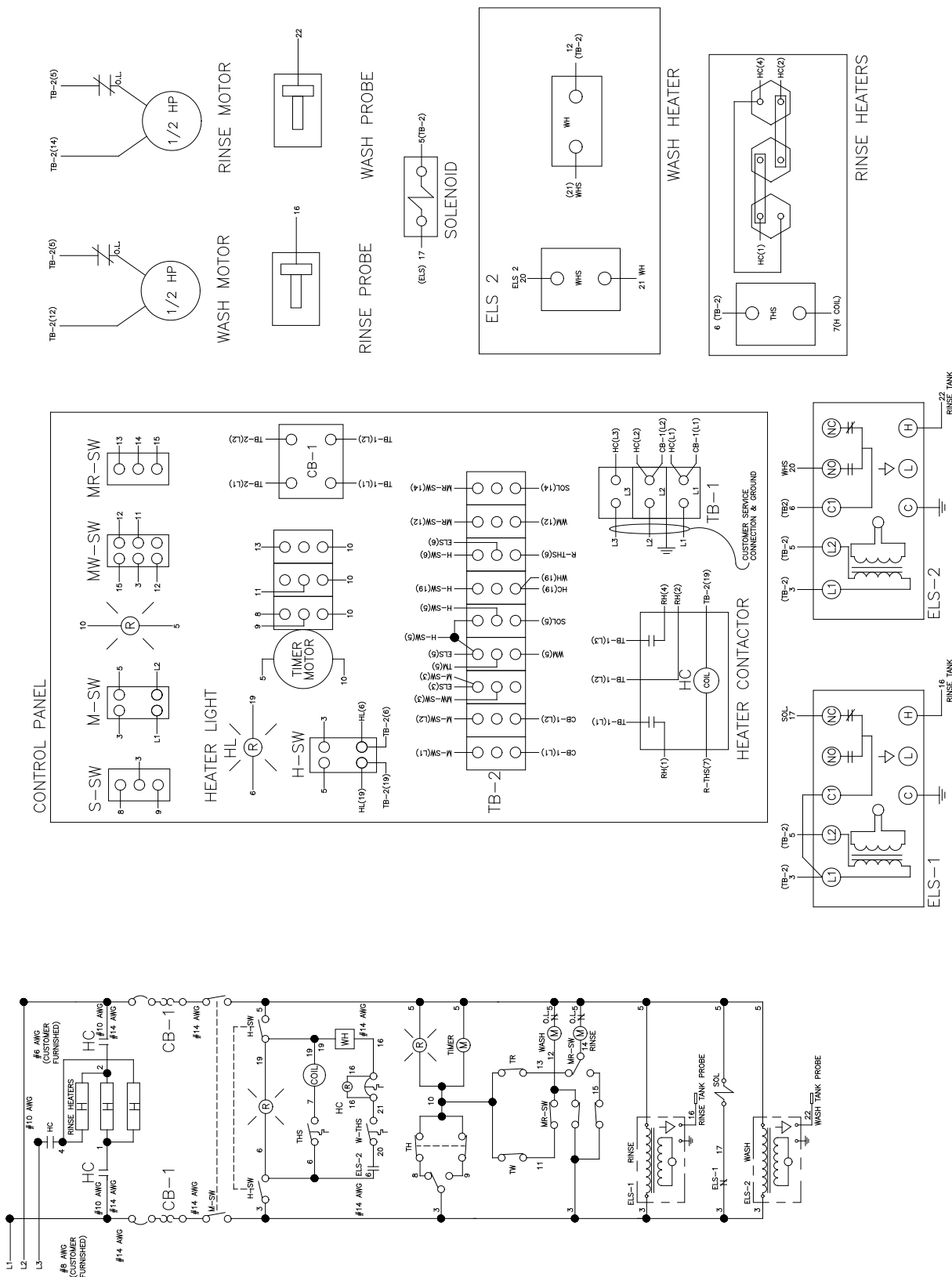



Jackson WWS, Inc. • 6209 N. US Hwy 25E • Gray, KY 40734 USA
1.888.800.5672 • www.jacksonwws.com