



COINCO GLOBAL 2<sup>®</sup> 800 SERIES  
OPERATION AND SERVICE MANUAL

# TABLE OF CONTENTS

---

## SECTION 1: GENERAL INFORMATION

Introduction .....	3
For Your Records .....	3
Features .....	4
After Unpacking .....	4
Specifications.....	4

## SECTION 2: INSTALLATION

Installing the Changer.....	5
Installation Diagrams .....	7

## SECTION 3: CONFIGURATION

Display Mode .....	9
Option Switch Module.....	10
Setting the Vend Price on a Single-Price Changer .....	11
Setting the Vend Price on a Four-Price Changer.....	12
Setting the Vend Price on a Protocol A Changer .....	13
Setting the Cashless Vend Price on a Protocol A Changer .....	13
Setting the Vend Price on MDB and BDV Changers.....	14
Manual Fill Mode .....	14
Float Mode.....	14
Setting the Float Mode Levels .....	15
Activating Float Pay-Down .....	15
Setting The “Use Correct Change” Value .....	16
Setting the Exact Change Accept Group .....	16
Reading Audit Information.....	18
Tube Counts.....	18
Digital Display Address Chart.....	19
Changing the Coin Tubes .....	23
Changing Coin Routing .....	23

## SECTION 4: MAINTENANCE

Routine Maintenance .....	25
Cleaning.....	25
Removing/Replacing Individual Modules.....	26
Clearing Coin Jams .....	26

## SECTION 5: TROUBLESHOOTING

Error Codes .....	27
Diagnostics .....	28
Troubleshooting Guide .....	29

## SECTION 6: EXPLODED VIEWS

Exploded Views.....	31
---------------------	----

# SECTION 1: GENERAL INFORMATION

---

## Introduction

This manual contains information on installing, operating and maintaining your COINCO GLOBAL2® coin changer. The manual is intended for owners, route operators and shop-level technicians as a primary source of information. Taking time to read this manual and becoming familiar with this information will help you obtain the best performance from your COINCO GLOBAL2® changer.

The COINCO GLOBAL2® Changer from Coin Acceptors can accept and validate up to 32 different coins or tokens. The COINCO GLOBAL2® Changer has the ability to be dual currency using a built in exchange rate convertor. It is programmable through a digital display making it easy to set up a user configuration. The COINCO GLOBAL2® Changer is compatible with current vending machine protocol standards as follows:

- **MDB:** For electronic vending machines that utilizes COINCO's Multi-Drop Bus technology.  
Note: All Global changers are equipped with the MDB interface as standard.
- **Single-Price/Four-Price:** For electromechanical vending machines.
- **Protocol 'A' (Executive):** For vending machines equipped with an electronic Protocol 'A' serial interface.
- **Protocol 'A' (Executive) with MDB Master:** As above with the additional ability to interface to MDB Bill validator or MDB Cashless devices whilst being connected to a vending machine in protocol 'A' mode.
- **BDV:** For vending machines equipped with an electronic BDV serial interface.

## For Your Records

A label indicating the coin changer model number and serial number can be found on the side of the coin changer. Refer to the model and serial number whenever you call upon your Coinco Service Centre for information or service. For your information, the first four digits of the serial number indicates when the unit was built which is also the beginning of the warranty period. The first two digits indicate the week of manufacture; the third and fourth digits indicate the year of manufacture. For example, Serial Number 1503005895 would indicate that the unit was manufactured in the 15th week of 2003.

The changer model number is shown in the following format:

**AAA-BXXXZ**

Where:

- AAA** The country/currency code. E.g. SEK = Swedish Krone, GBP = Great Britain Pound.
- B** The primary protocol of the changer
  - G = MDB only
  - F = Four/Single-price Electromechanical
  - A = Protocol 'A' (Executive)
  - B = BDV(Note: All models have MDB in addition to the primary protocol)
- XXX** The first digit of the model number indicates the series of the changer 7, 8 or 9. The last two digits indicates the changers payout configuration.
- Z** Indicates any special options.

# SECTION 1: GENERAL INFORMATION

---

## Features

- The COINCO GLOBAL 2<sup>®</sup> coin changer has a modular design for easy service.
- Tubes snap in and out of housing for easy customization of your changer
- Pays out change from self-loading, high capacity change tubes
- Two motors provide fast, accurate payout.
- Programmable tube floats allow variable tube level adjustment.
- State-of-the-art electronic logic system is designed for reliability and performance.
- Lightweight, rugged plastic construction.
- All models equipped with the MDB protocol.
- Lockable coin loading door allows easy hand-loading of coin tubes while keeping dirt and debris out of the changer.
- The Protocol 'A' (Executive) changer has the ability to be an MDB master to a either Bill validator or cashless system.

## After Unpacking

After unpacking the unit, inspect it for any possible shipping damage. If the unit is damaged, notify the shipping company immediately. Only the consignee (the person or company receiving the unit) can file a claim against the carrier for shipping damage. We recommend that you keep the original shipping carton and packing materials to reuse if you need to transport or ship your changer in the future.

If the coin changer is being stored or used as a spare, always keep it in its shipping carton when not in use. This will keep it clean and offer the best protection for the unit.

## Specifications

### Power Requirements (by model)

MDB .....	34V DC
Single/Four Price .....	24V AC, 50/60 Hz 120V AC, 50/60 Hz 220V-240V AC, 50/60 Hz
Protocol A.....	24V AC, 50/60 Hz
L/L+ .....	24V DC
BDV .....	24V DC

### Operating Temperature Non-Metric/Metric

0 to 150 Degrees Fahrenheit  
-18 to 65 Degrees Celsius

### Storage Temperature Non-Metric/Metric

-22 to 160 Degrees Fahrenheit  
-30 to 72 Degrees Celsius

### Relative Humidity

20% to 98% Noncondensing

### Operating Attitude

Vertical  $\pm$ 3 degrees

### Physical Dimensions Metric/Non-Metric

Height:	BASE TO TOP OF COIN RETURN LEVER 379.2mm (14.93 inches)
Width:	138.9mm (5.47 inches)
Depth:	GATE OPEN 82.5mm (3.25 inches) GATE CLOSED 76.2mm (3.00 inches)

### Weight in Shipping Carton Non-Metric/Metric

Approximately 7 pounds  
Approximately 3.15 kilograms

### Coin Size Range

Up to 32 coins or tokens in the size range of 15.0 to 33.5 mm diameter and 1.02 to 3.10 mm thickness can be validated.

## SECTION 2: INSTALLATION

### Installing The Changer

1. Remove power from the vending machine.
2. Remove the acceptor from the changer by releasing acceptor latch and rotating the top of the acceptor forward, away from changer (see Figures 1 and 2). Unplug ribbon cable from changer. Free acceptor studs from changer housing. Place the acceptor in a clean area.
3. With the acceptor removed, set the mounting holes in the back of the changer housing over the mounting screws in the vending machine. Tighten securely (see Figure 3). Do not over tighten as this could damage the changer housing.
4. Replace the acceptor by inserting bottom acceptor studs into changer housing guides. Plug the ribbon cable into the changer (see Figure 2).

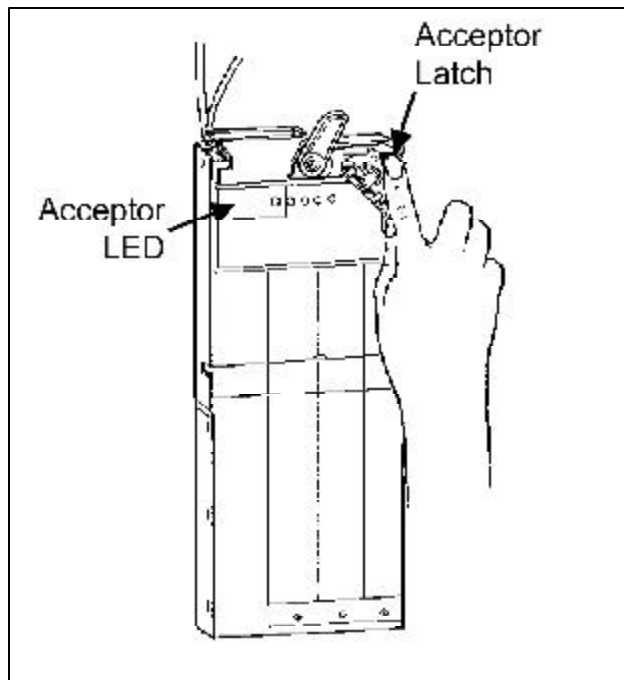


Figure 1

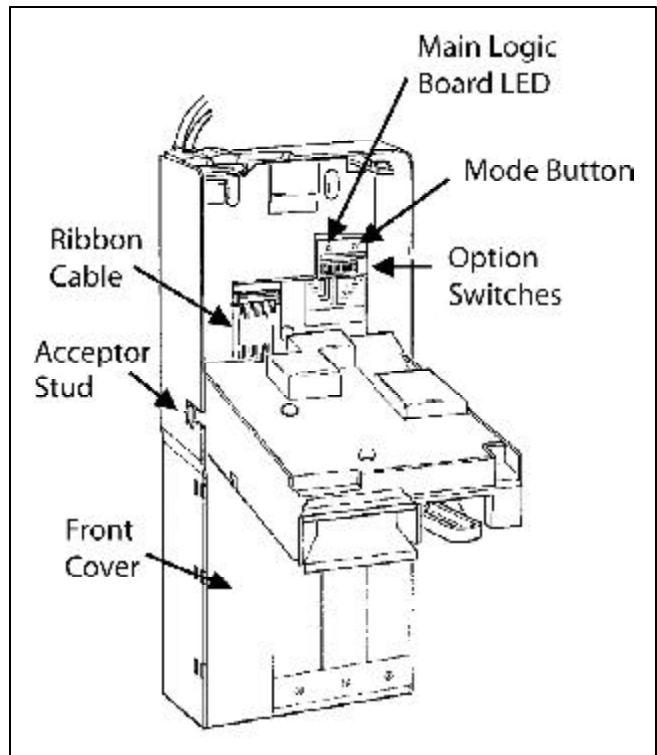


Figure 2

5. On units that use a DEX/UCS Hand-held Computer, attach DEX Plug Ground Connector to the vending machine frame.
6. Connect the appropriate interface harness to the vending machine. See typical setup examples for the protocol being used:  
Figure 5 for MDB  
Figure 6 for Protocol 'A' (Executive)  
Figure 7 for Protocol 'A' (Executive) with MDB master.  
Figure 8 for 4-Price Electromechanical
7. Set the desired vend price and options on the changer. Refer to Section 3: Configuration  
Note: The vend prices are set on the vending machine controller when operating in MDB mode or Protocol 'A' non-price holding.

## SECTION 2: INSTALLATION

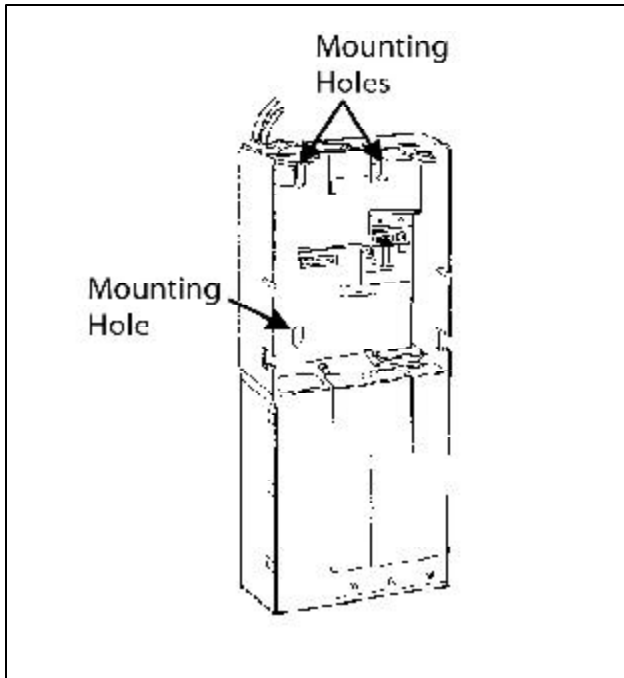


Figure 3

8. Press the top of the acceptor into the changer housing until the acceptor latches and locks.
9. If coin tube loading door is not locked (additional option) hand load the four coin tubes (see Figure 4). Tilting the coin tube loading door open, load the four coin tubes. Make sure all coins lie flat and that each tube is filled at least to the 20% mark. Payout at least two coins from each tube to set tube counters.

Note: Hand loading the tubes will not give an accurate audit reading. If audit is required, the tubes should be loaded in Fill mode see relevant section of this manual for further details.

10. Check to make sure the tube cover and acceptor studs are properly installed.
11. Test the coin changer with a variety of coins to ensure proper operation.

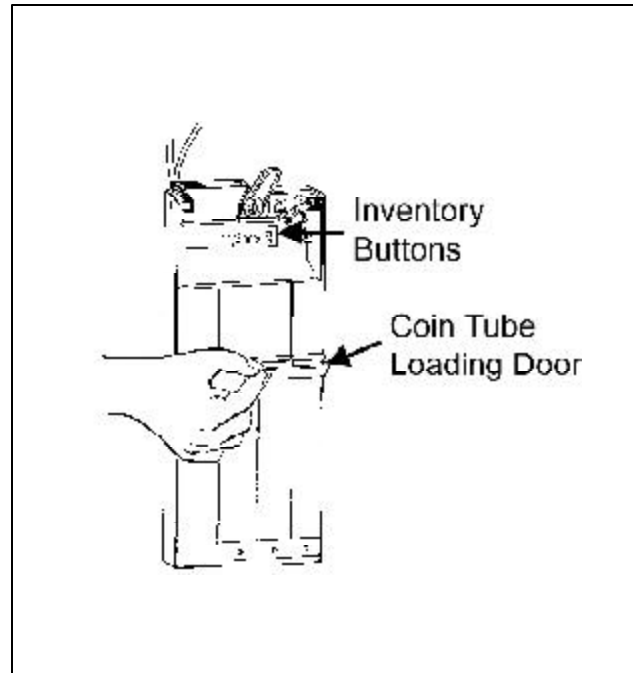
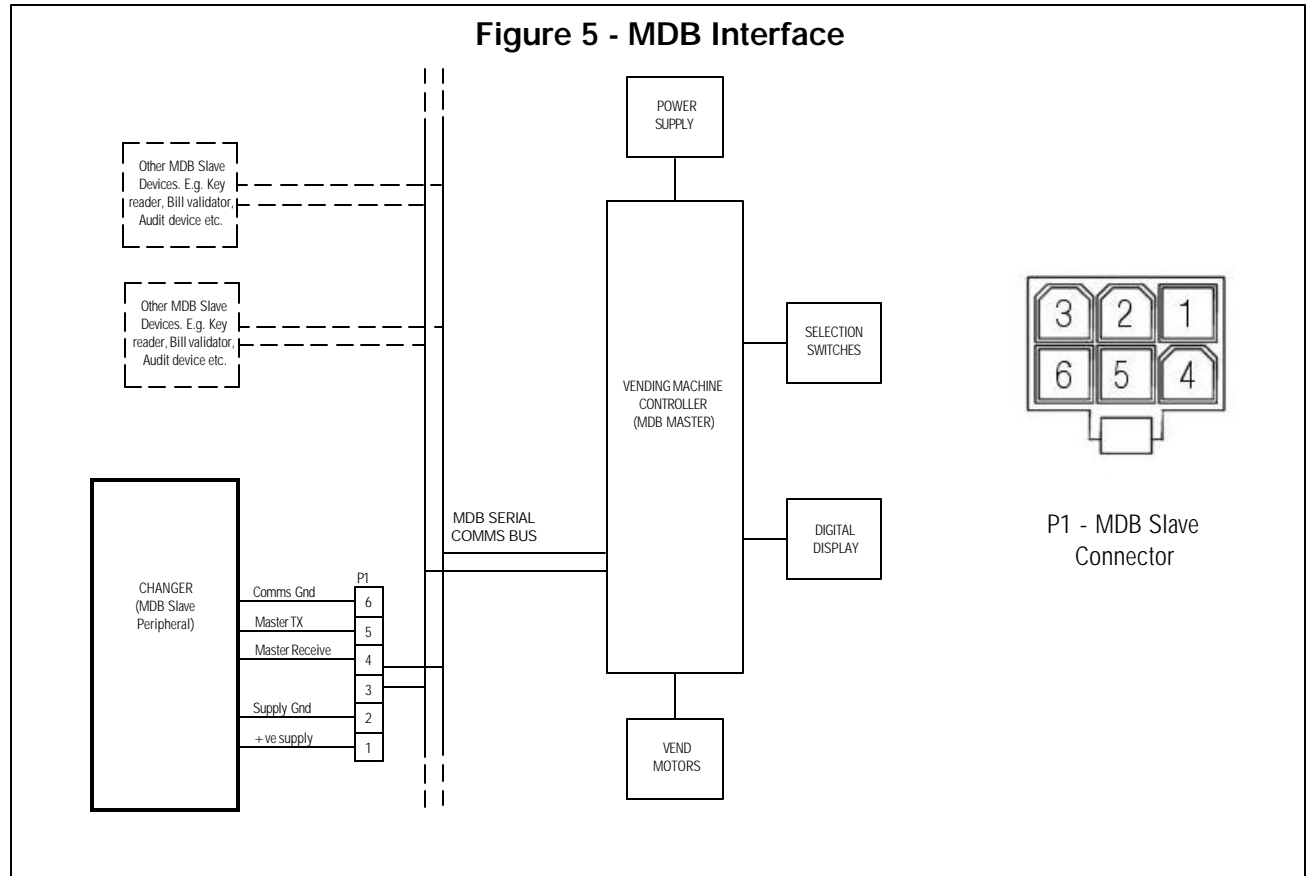


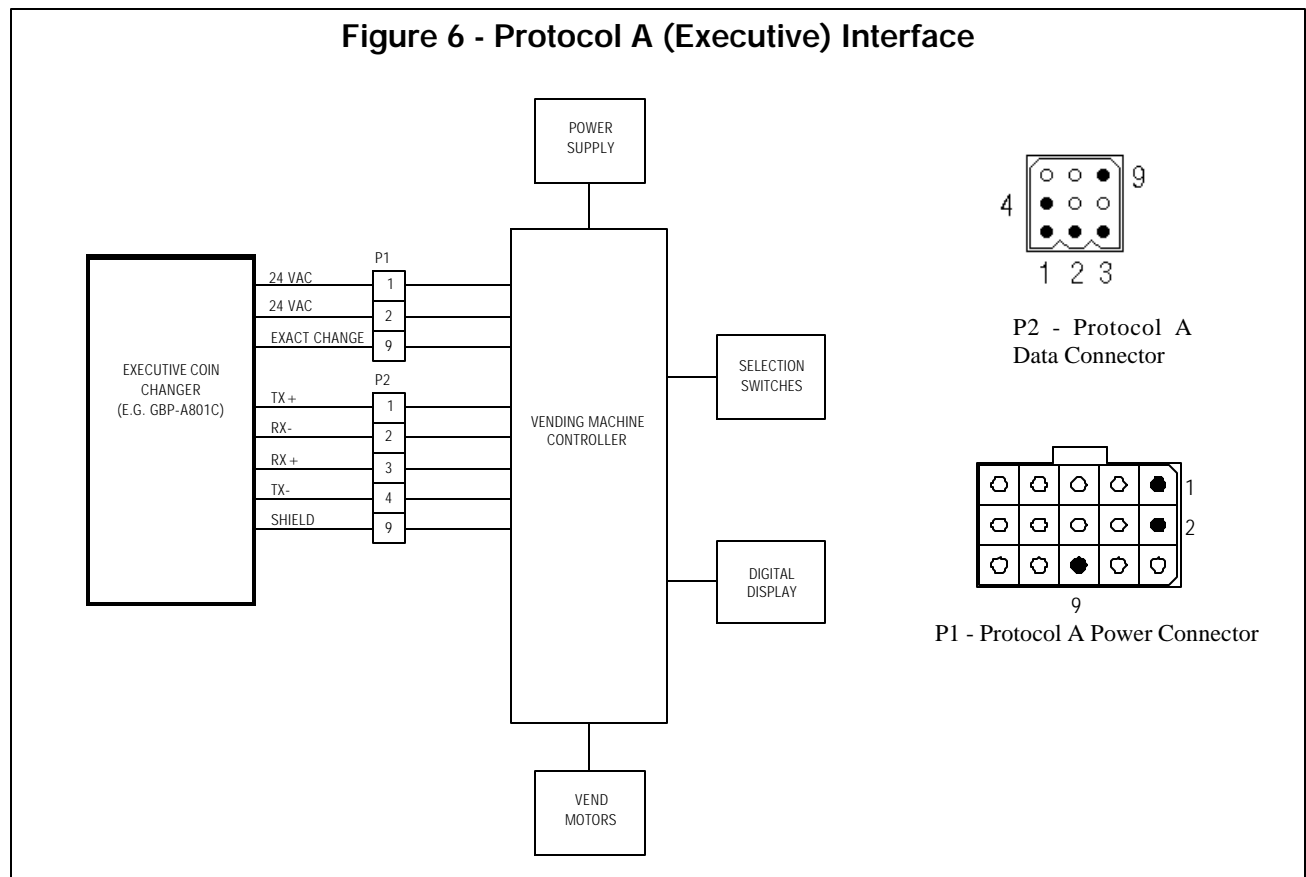
Figure 4

# SECTION 2: INSTALLATION

**Figure 5 - MDB Interface**

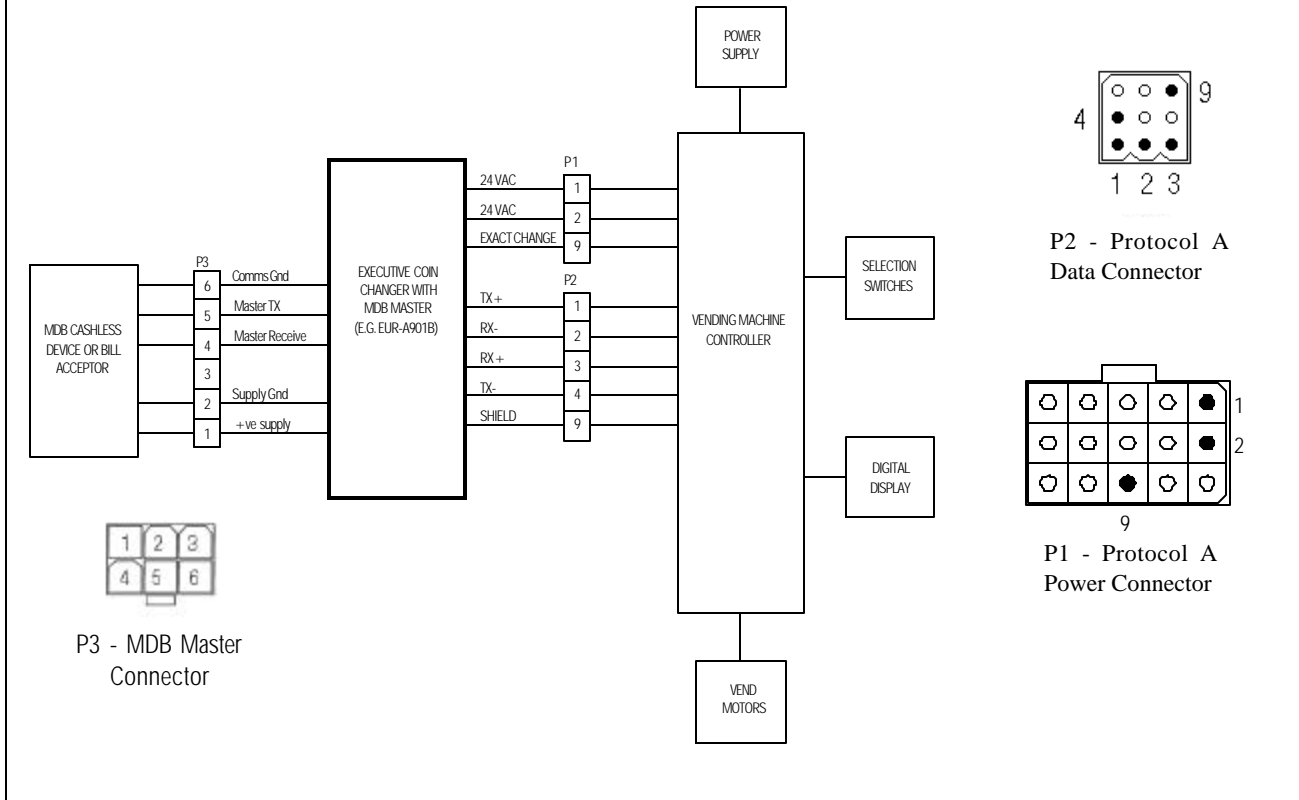


**Figure 6 - Protocol A (Executive) Interface**

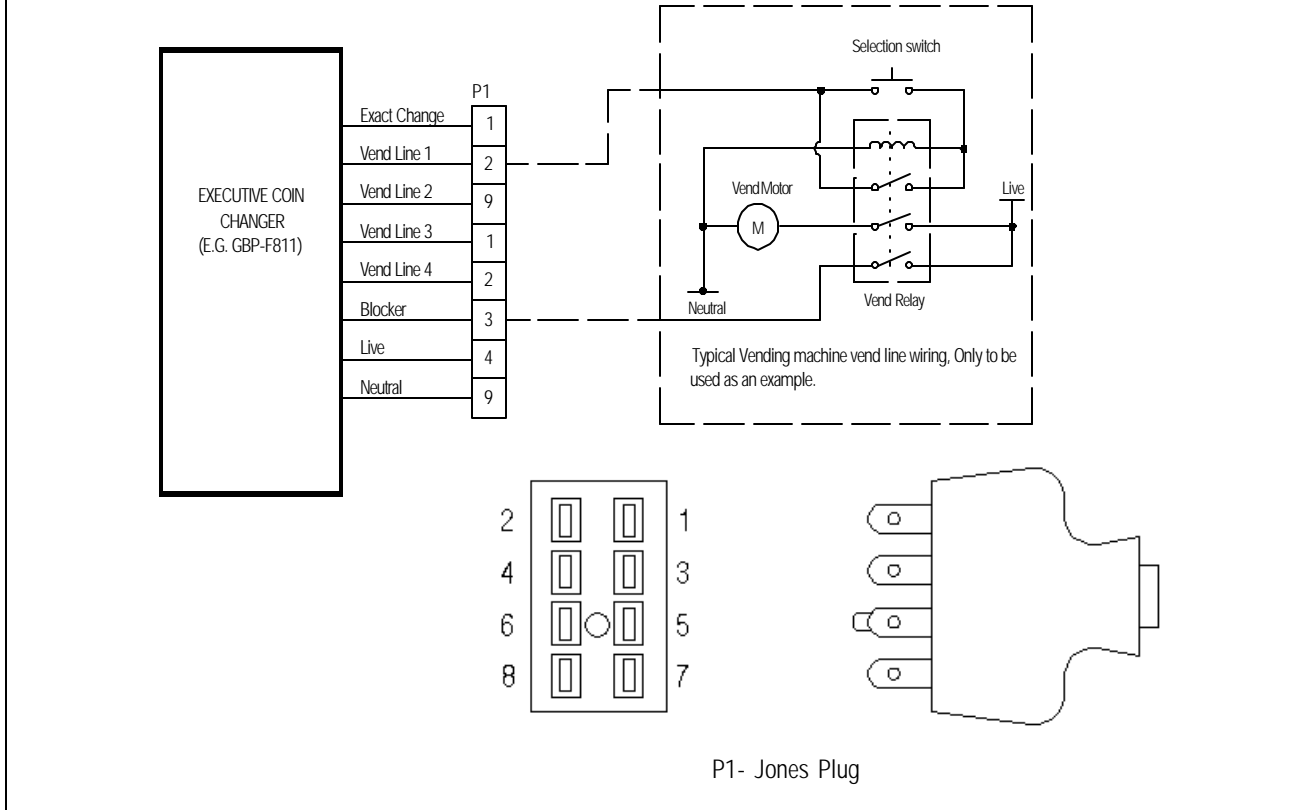


# SECTION 2: INSTALLATION

**Figure 7- Protocol A (Executive) Interface with MDB Master Support**



**Figure 8 - Four Price Electro-Mechanical Interface**





# SECTION 3: CONFIGURATION

## Display Mode

The 800 Series changer is equipped with a four-digit, seven-segment display, located on the acceptor gate. The Display Mode is utilized via the four Inventory Buttons also located on the acceptor gate (see Figure 9).

This Display Mode is used to read information as well as to set different options including price settings and tube float levels.

The Display Mode may be entered by pressing Inventory Buttons A and D simultaneously. In response, the display will turn on the message “FILL”, “FULL”, or “AbCd”. Button activation will be recognized only if longer than 0.5 seconds. Once you have entered the Display Mode, Inventory Buttons A through D are used to move through the addresses as follows:

**Button A** ..... ESCAPE  
**Button B** ..... INCREASE  
**Button C** ..... ENTER  
**Button D** ..... DECREASE

*EXAMPLE: Simultaneously press A and D to enter Display Mode. Press B to increase (scroll) through the various addresses. Once you have reached the address you need to access, press Button C to enter the address. Information currently stored in non-volatile memory will be displayed with the far right decimal point illuminated. Use either Inventory Buttons B or D to increase or decrease the address values as needed. Press Button C again to store the selection. Press A to return to the Address Display. Press A again to exit the Display Mode.*

You will exit the Display Mode if one of the following procedures is performed:

1. No Inventory Buttons are pressed or coins are dropped for more than 45 seconds;
2. Depressing the A Button until the Display Mode is exited;
3. Automatic exit after hardware reset.

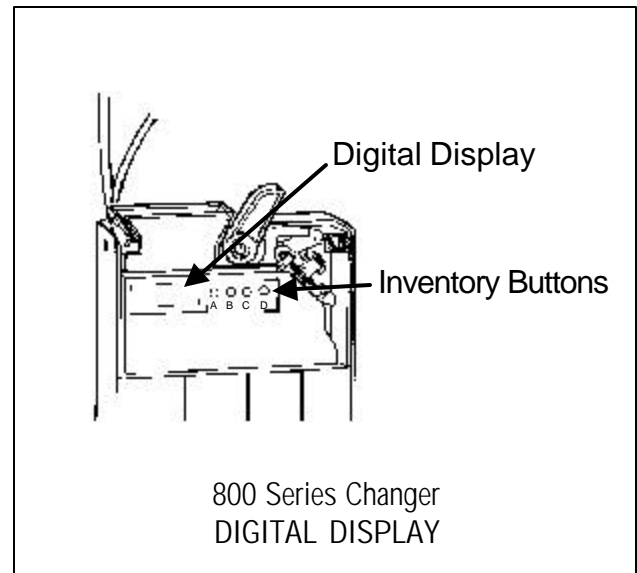


Figure 9

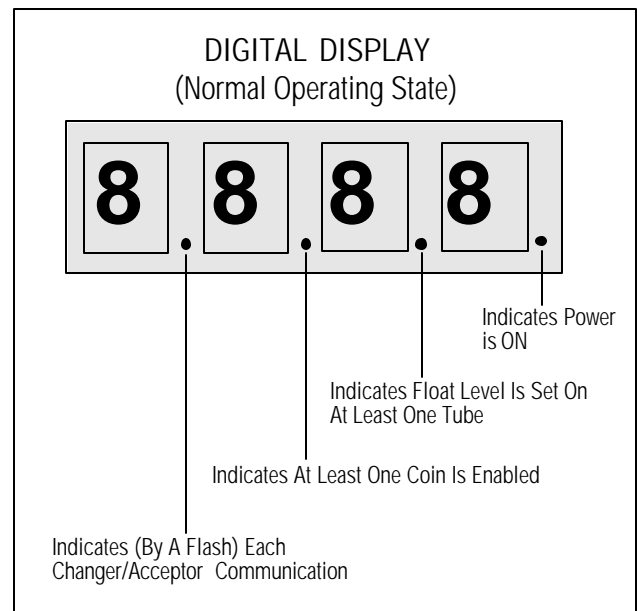


Figure 10

**NOTE:** All addresses in the Display Mode can be made “Read Only” (disabled) via Coinco Support Software (see separate Coinco Support software manual for further information).

**NOTE:** If power is removed from the changer before the Display Mode is exited, the changes may not be saved.

# SECTION 3: CONFIGURATION

---

## Option Switch Module

Single-Price/Four-Price Models Only

Located behind the acceptor on the middle right hand side of the changer housing are twelve switches (see Figure 2). The first eight are used to set the vend price (see “Setting The Vend Price” section of this manual).

The last four Option Switches are used to enable or disable the following options:

Note: The switches are ON in the upwards position.

### Switch A (SW9)

Controls whether the escrow feature of the changer is inhibited.

ON Escrow inhibited.

OFF Escrow not inhibited.

### Switch B (SW10)

Determines the operation mode of the changer.

ON Operates as a Four-Price changer.

OFF Operates as a Single-Price changer.

### Switch C (SW11)

*(Single-Price Mode Only)*

Controls the vend holding feature.

ON Vend is held until selection is made.

OFF Vend is pulsed.

### Switch D (SW12)

Controls when the changer enters the “Use Correct Change” condition.

ON Uses the sum of the highest price plus the value of the highest coin for the “Use Correct Change” indicator.

OFF Uses a programmable value for “Use Correct Change” indicator. “Use Correct Change” indicator is illuminated when changer is unable to make change for the programmed value or any lesser value.

## SECTION 3: CONFIGURATION

### Setting The Vend Price On A Single-Price Changer

The vend price on a single-price changer may be set in four ways:

- via Coinco Support Software
- via DEX/UCS
- via the first eight Option Switches
- via the digital display.

The vend price can be set in single increments up to 255 times the lowest denomination coin that is accepted by the changer and routed to a coin tube.

*EXAMPLE: If the lowest denomination coin is one, the highest vend price setting would be 255 x 1 or 255.*

#### VIA COINCO SUPPORT SOFTWARE

Consult Coinco Support Software manual for price setting instructions.

#### VIA DEX/UCS

Consult Hand-held Computer manufacturer.

#### VIA OPTION SWITCHES

Note: The switches are ON in the upwards position.

1. Set the vend price by adding the amount of the appropriate switches and setting them to the ON position (see Figure 11).
2. Set Option Switch B to the OFF position.
3. Set Option Switches A, C and D to the desired configuration (see “Option Switch Module” section of this manual).
4. After setting the vend price and the desired options, press and release the Mode Button to store the new setting. The LED and the “Use Correct Change” light will then flash once, indicating that the price was recorded.

Switch 1 .....	1 x Scaling Factor
Switch 2 .....	2 x Scaling Factor
Switch 3 .....	4 x Scaling Factor
Switch 4 .....	8 x Scaling Factor
Switch 5 .....	16 x Scaling Factor
Switch 6 .....	32 x Scaling Factor
Switch 7 .....	64 x Scaling Factor
Switch 8 .....	128 x Scaling Factor

Figure 11

*Example: Switch 1, 3, 4, set to on and the remaining set to off would result in a price of  $(1+4+8) \times \text{Scaling Factor}$ . If the scaling factor were set to 5 and the decimal point set to 2, the resulting price setting would be  $(1+4+8) \times (.05) = 13 \times .05 = 0.65$  units. The current scaling factor can be displayed using display mode, address “A010” on the acceptor. The current decimal point position can be displayed using diplay mode, address “A011”.*

*NOTE: The vend price must be set to an amount greater than zero for the changer to accept coins in single-price mode.*

#### VIA DIGITAL DISPLAY

1. Enter the Display Mode (see “Display Mode” section of this manual).
2. Press B to scroll up to “C001” (Price 1).
3. Press C to enter. The current Price Setting is displayed.
4. Use buttons B (increase) and D (decrease) to change C001 to the appropriate price.
5. Press A to store price and return to the Display Mode.
7. Press A to exit the diplay mode.

Note: The Display Mode will exit automatically if there is no programming action for 30 seconds.

## SECTION 3: CONFIGURATION

---

### Setting The Vend Price On A Four-Price Changer

The vend price on a four-price changer may be set in four ways:

- via Coinco Support Software;
- via DEX/UCS;
- via the first eight Option Switches;
- via the digital display.

The vend price can be set in single increments up to 255 times the lowest denomination coin that is accepted by the changer and routed to a coin tube.

*EXAMPLE: If the lowest denomination coin is one, the highest vend price setting would be 255 x 1 or 255.*

#### VIA COINCO SUPPORT SOFTWARE

Consult Coinco Support Software manual for price setting instructions.

#### VIA DEX/UCS

Consult Hand-held Computer manufacturer.

#### VIA OPTION SWITCHES

Note: The switches are ON in the upwards position.

1. To set the vend price of a selection, add the value of the rocker switches that are switched to the ON position (see Figure 11).
2. Set Option Switch B to the ON position.
3. Set Option Switches A, C and D to the desired configuration (see “Option Switch Module” section of this manual).
4. After setting the desired vend price on the Option Switch Module, press and release the Mode Button (see Figure 2). The changer’s Main Logic Board LED and the “Use Correct Change” light will begin to flash.

5. Within 30 seconds, press and release any one desired product selection switch on the front of the machine. The present price on the switch module is now set for all selections on that price line and the LED and “Use Correct Change” light will stop flashing.
6. Repeat the above steps until the remaining three price lines have been assigned a vend price.

*EXAMPLE: If the first, fourth and fifth price setting switches are in the UP position, the vend price setting would be 25 x 1 or 25 (assuming the lowest denomination coin accepted is 1).*

*NOTE: If the price for one or more of the selections is set to zero, that selection is a free vend.*

#### VIA DIGITAL DISPLAY

1. Enter the Display Mode (see “Display Mode” section of this manual).
2. Press B to scroll up to C001 (Price 1).
3. Press C to enter. The current price setting is displayed.
4. Use buttons B (increase) and D (decrease) to change C001 to the appropriate price.
5. Press A to set the price and return to the Display Mode.
6. Press B to increase to the next priceline - E.g. Address C002 (Priceline 2).
7. Repeat steps 3-6 for the remaining three prices.
8. Once all four prices have been set, press A twice to exit the Display Mode.

## SECTION 3: CONFIGURATION

---

### Setting The Vend Price On A Protocol A Changer

The vend price on a Protocol A changer may be set in three ways:

- via Coinco Support Software;
- via DEX/UCS;
- via the digital display

#### SETTING THE STANDARD PRICELINES

If the vending machine operates in Price Holding Mode, then the twenty-five prices are set using Addresses C101-C125 accordingly.

1. Enter the Display Mode (see “Display Mode” section of this manual).
2. Press B to scroll up to Address C101 (For Priceline 1)
3. Press C to enter. The current price setting is displayed.
4. Use buttons B (increase) and D (decrease) to change the value to the desired price.
5. Press A to store price and return to the Display Mode.
6. Press B to increase to the next priceline - E.g. Address C102 (Priceline 2)
7. Repeat steps 3-6 for the remaining priceline addresses.
8. Once all twenty-five prices have been set, press A to exit the Display Mode.

#### SETTING THE NUMBER OF ACTIVE PRICELINES (C055)

If the vending machine operates in Price Holding Mode then the number of price lines available that are recorded in audit can be set using address C055.

1. Enter the Display Mode (see “Display Mode” section of this manual).
2. Press B to scroll up to C055.
3. Press C to enter Address C055.
4. Use buttons B (increase) and D (decrease) to change the number of price lines in Address C055.

5. Press A to store the value and return to the Display Mode.
6. Press A to exit the Display Mode.

#### ENABLING CASHLESS PRICELINES (C053)

If the vending machine operates in Price Holding Mode, address C053 is used to enable the Cashless pricelines C201 to C225.

1. Enter the Display Mode (see “Display Mode” section of this manual).
2. Press B to scroll up to Address C053.
3. Press C to enter C053.
4. Use buttons B (increase) or D (decrease) to change the value.  
0 = Enable price lines  
1 = Disable price lines
5. Press A to store the value and return to the Display Mode.
6. Press A to exit the Display Mode

#### SETTING THE CASHLESS PRICELINES

If the vending machine operates in Price Holding Mode, the cashless pricelines are set using Addresses C201-C225. When a vend is made using credit from an MDB Cashless device the prices stored in these addresses will be used. Cash vends will still use the prices stored in addresses C101 to C125.

1. Enter the Display Mode (see “Display Mode” section of this manual).
2. Press B to scroll up to C201.
3. Press C to enter Address C201.
4. Use buttons B (increase) and D (decrease) to change the value to the desired price.
5. Press A to store the price and return to the Display Mode.
6. Press B to increase to the next priceline - E.g. Address C202 (Cashless priceline 2).
7. Repeat steps 3-6 for the remaining pricelines.
8. Once all twenty-five prices have been set, press A to exit the Display Mode.

## SECTION 3: CONFIGURATION

---

### Setting The Vend Price on MDB & BDV Changers

Vend prices for MDB/BDV changers are set through the vending machine controller (VMC). See vending machine manual for details.

### Manual Fill Mode

Manual Fill Mode allows coins to be inserted into the acceptor which routes the coins to the proper coin tube without establishing credit. When high sensor level or float level is reached and in manual fill mode, coins will be rejected. Enter the Display Mode (see “Display Mode” section of this manual). When “FILL” appears in the display, deposit coins until the desired level. Alternating with the “FILL” message will be the tubes needing coins “AbCd”. The changer will automatically return to operating mode after 45 seconds of no activity or if button A (escape) is pressed.

*Manual Fill Mode is supported for Single-/Four-Price, Protocol A, and BDV changers. Manual Fill Mode in MDB changers is accessed through the vending machine controller. See vending machine manual for details.*

### Float Mode

Float Mode is used to systematically reduce the number of coins kept in a tube.

The 800 Series GLOBAL2® changer supports two Float Mode Options which are set through the use of Coinco Support Software or the digital display.

#### STANDARD LEVEL FLOAT MODE

In Standard Float Level Mode, once a tube float level is set (see “Setting The Float Mode Levels” section), the changer will try to maintain the set level of coins in the tube by routing accepted coins to the tube *only* if a coin was paid out. Once the tube reaches its float level in Standard Float Mode, any coins normally routed to that tube will be sent to the cashbox. As usual, any cashbox coins will be accepted and routed to the cashbox.

#### FLOAT PAY-DOWN MODE

In Float Pay-down Mode, the acceptor will continue to route coins to the tube until the upper sensor is covered. The coins will then be routed to the cashbox. Once a tube float level is set, activating Float Pay-down will dispense coins above the established levels until the coins reach the float levels (see “Activating Float Pay-down” section of this manual).

When in Manual Fill Mode, the acceptor will route coins to the tube until float level is reached. When float level is reached the display will change to “FULL” and coins will be rejected. The float pay-down level does not change. The changer will automatically return to operating mode after 45 seconds of no activity or if button A (escape) is pressed.

## SECTION 3: CONFIGURATION

---

### Setting The Float Mode Levels

The Float Mode Levels for both Float Level and Float Pay-down can be set in two ways:

- via Coinco Support Software;
- via the Digital Display.

#### VIA COINCO SUPPORT SOFTWARE

Consult Coinco Support Software manual for tube float level setting instructions.

#### VIA DIGITAL DISPLAY

The Digital Display/Inventory Buttons are located on the acceptor gate. Address “A007” allows you to clear all float levels and to set all four float levels at one time. The individual tube float levels are set using Address “A008”.

#### Setting All Four Float Levels At Once:

1. Load the four coin tubes to the float level you want the coin changer to maintain.
2. Enter the Display Mode (see “Display Mode” section of this manual).
3. Press B to scroll up to Address “A007”
4. Press C to enter Address “A007”. The display will show the current float mode settings for all tubes. The far left digit represents tube A through the far right digit representing tube D.
5. Press B (increase) or D (decrease) to “1” to set standard float levels, “2” for float pay-down, or “0” to disable float mode.
6. Press C to enter your selection. The far right decimal point will illuminate indicated the selection has been stored.
7. Press A to return to the Address selection.
8. Press A again to exit display mode. All four tube float levels are now set.

The Digital Display’s second decimal point from the right will be illuminated if any tube float levels have been set.

#### Setting Float Levels Individually:

1. Load the individual coin tube to the float level you want the coin changer to maintain.
2. Enter the Display Mode (see “Display Mode” section of this manual).
3. Press B to scroll up to Address “A008” for individual tube float setting.
4. Press C to enter the Address.
5. “A” will be displayed indicating tube “A”. Use button B (increase) or button D (decrease) to reach the desired tube selection.
6. Press C to enter the Sub Address.
7. Use button B (increase) to reach the correct setting (“0” to disable, “1” for standard float, “2” for float pay-down).
8. Press C to store setting. The far right decimal point will illuminate indicating the selection has been stored.
9. Press C again to return to the Sub Address Display.
10. Press A to return to the Address Display.
11. Press A again to exit the Display Mode. The tube float level is now set for the individual tube you have chosen.

The Digital Display’s second decimal from the right will be illuminated if any tube float levels have been set.

### Activating Float Pay-Down

Pressing and releasing buttons A and B simultaneously activates Float Pay-down. Use Manual Fill to replenish low tubes (see “Manual Fill Mode” section of this manual).

## SECTION 3: CONFIGURATION

---

### Setting The “Use Correct Change” Value

Single-/Four-Price and Protocol A Models Only

When a value is selected for turning on the “Use Correct Change” light, the light is illuminated when the changer is unable to make change for *THAT* value or any lesser value.

*NOTE: Option switch D set to the ON position will override any setting you make via the following instructions. See “Option Switch Module” section of this manual for information on Option Switch D.*

The “Use Correct Change” light can be programmed to come on in three ways:

- via Coinco Support Software;
- via DEX/UCS (Protocol A Only);
- via the Digital Display.

#### VIA COINCO SUPPORT SOFTWARE

Consult Coinco Support Software manual for “Use Correct Change” light setting instructions.

#### VIA DEX/UCS

Consult Hand-held Computer manufacturer.

#### VIA DIGITAL DISPLAY

The “Use Correct Change” light is set using Address “C032” of the Digital Display.

1. Enter the Display Mode (see “Display Mode” section of this manual).
2. Press B to scroll up to Address “C032” (“Use Correct Change” Setting).
3. Press C to enter the Address.
4. Use button B (increase) or button D (decrease) to reach the correct value.
5. Press C to store setting.
6. Press A to return to the Address Display.
7. Press A again to exit the Display Mode. The Exact Change Setting is now programmed to the value you have set.

### Setting The Exact Change Accept Group

Single-/Four-Price and Protocol A Models Only

By setting the Exact Change Group you are telling the changer what coins to accept when the “Use Correct Change” light is ON. When the light is OFF, all enabled coins in the coin set are accepted.

The Exact Change Group can be programmed in three ways:

- via Coinco Support Software;
- via DEX/UCS;
- via the Digital Display.

#### VIA COINCO SUPPORT SOFTWARE

Consult Coinco Support Software manual for “Use Correct Change” light setting instructions.

#### VIA DEX/UCS

Consult Hand-held Computer manufacturer.

#### VIA DIGITAL DISPLAY

The Exact Change Group is set using Address “C014” of the Digital Display.

1. Enter the Display Mode (see “Display Mode” section of this manual).
2. Press B to scroll up to Address “C014”
3. Press C to enter the Address.
4. Use button B (increase) or button D (decrease) to reach the coin value or Exact Change group to be accepted.
5. Press A to return to the Address Display.
6. Press A to exit the Display Mode. The Exact Change coin value/group is now programmed to the value you have set.



## SECTION 3: CONFIGURATION

---

### FOUR PRICE EXACT CHANGE GROUP SETTINGS (Address C014)

- 0 ..... Accepts only coin number 0
- 1 ..... Accepts coin numbers 0 through 1
- 2 ..... Accepts coin numbers 0 through 2
- 3 ..... Accepts coin numbers 0 through 3
- 4 ..... Accepts coin numbers 0 through 4
- 5 ..... Accepts coin numbers 0 through 5
- 6 ..... Accepts coin numbers 0 through 6
- 7 ..... Accepts coin numbers 0 through 7
- 8 ..... Accepts coin numbers 0 through 8
- 9 ..... Accepts coin numbers 0 through 9
- 10 ..... Accepts coin numbers 0 through 10
- 11 ..... Accepts coin numbers 0 through 11
- 12 ..... Accepts coin numbers 0 through 12
- 13 ..... Accepts coin numbers 0 through 13
- 14 ..... Accepts coin numbers 0 through 14
- 15 ..... Accepts all coins

*Note: Coins of the same value are reported as the same coin number. Coin Number 0 is the first coin value accepted, coins that are disabled are not reported. E.g. In the EUR-A901 the 1c and 2c are disabled therefore the first coin accepted is the 5c so this is coin number 0.*

### PROTOCOL A EXACT CHANGE GROUP SETTINGS

C014 will list all coins accepted. Select the coin value - all coins up to and including this value will be accepted when the exact change light is ON

## SECTION 3: CONFIGURATION

---

### Reading Audit Information

Single-/Four-Price and Protocol A Models Only

By reading Audit Information, you can gain valuable information about your vendor's performance. Audit information is retrieved via the Digital Display by performing the following steps:

1. Enter the Display Mode (see "Display Mode" section of this manual).
2. Press C. In response, the display will show Address "d000".
3. Press B or D to scroll to the desired audit address (see Audit Information Addresses).
4. Press C to view the upper four digits of the displayed address. Press C again to view the lower four digits, including the decimal point (if any). *EXAMPLE: 10,480.20 would be displayed as 0104 in the upper four digits followed by 80.20 in the lower four digits.*
5. Press C again to return to the Address Display.
6. Press A to exit to the "FULL/FILL AbCd" message.

*NOTE: Audit Information is "read only" it can only be reset using Coinco Support software. or if address C049 is enabled (Use address C050 to clear audit data)*

*NOTE: Free vends issued directly from the vending machine are not audited by the changer.*

### Tube Counts

By briefly depressing and releasing an inventory button, you can obtain information about the coin value and the quantity of coins within the tube.

# SECTION 3: CONFIGURATION

DIGITAL DISPLAY AUDIT INFORMATION ADDRESSES			Y=Supported N=Not Supported			
Address	Field	Description	G	SF	A	BDV
D000	Total number of vends	Total number of vends	N	Y	Y	N
D001	Cash to tubes	Total value of coins routed to tubes	N	Y	Y	N
D002	Cash to cash box	Total value of coins routed to cash box	N	Y	Y	N
D003	Dispensed cash	Total value dispensed	N	Y	Y	N
D004	Inventoried cash	Total value dispensed using inventory buttons	N	Y	Y	N
D005	Overpay value	Change lost	N	Y	Y	N
D006	Vend value	Total value of all vends	N	Y	Y	N
D007	Exact change vend value	Value of vends taken when exact change light is on	N	Y	Y	N
D008	Discount value	Actual value of discount given	N	N	Y	N
D009	Token value	Value of vends from tokens	N	N	Y	N
D010	Prepaid card value	Value taken from prepaid cards	N	N	Y	N
D011	Total vends for price 1	Count of vends for price 1	N	Y	Y	N
D012	Total vends for price 2	Count of vends for price 2	N	Y	Y	N
D013	Total vends for price 3	Count of vends for price 3	N	Y	Y	N
D014	Total vends for price 4	Count of vends for price 4	N	Y	Y	N
D015	Total vends for price 5	Count of vends for price 5	N	N	Y	N
D016	Total vends for price 6	Count of vends for price 6	N	N	Y	N
D017	Total vends for price 7	Count of vends for price 7	N	N	Y	N
D018	Total vends for price 8	Count of vends for price 8	N	N	Y	N
D019	Total vends for price 9	Count of vends for price 9	N	N	Y	N
D020	Total vends for price 10	Count of vends for price 10	N	N	Y	N
D021	Total slugs rejected	Count of number of invalid coins	N	Y	Y	N
D022	Total # coins tube 1	Total coins in lowest value tube	N	Y	Y	N
D023	Total # coins tube 2	Total coins in second lowest value tube	N	Y	Y	N
D024	Total # coins tube 3	Total coins in second highest value tube	N	Y	Y	N
D025	Total # coins tube 4	Total coins in highest value tube	N	Y	Y	N
D026	Total value coins tube 1	Total value of coins	N	Y	Y	N
D027	Total value coins tube 2	Total value in second lowest value tube	N	Y	Y	N
D028	Total value coins tube 3	Total value in second highest value tube	N	Y	Y	N
D029	Total value coins tube 4	Total value of coins in highest value tube	N	Y	Y	N
D030	Value card sales life	Value sales from prepaid period	N	N	Y	N
D031	Value card credit life	Value credit to prepaid card	N	N	Y	N
D032	Value card discount life	Value discounts during prepaid card use	N	N	Y	N

# SECTION 3: CONFIGURATION

DIGITAL DISPLAY AUDIT INFORMATION CHANGER ADDRESSES				Y=Supported N=Not Supported R=Read Only		
Address	Field	Description	G	S/F	A	BDV
C001	Prices 1 (Repeated at address C101)	Value	N	Y	Y	N
C002	Prices 2 (Repeated at address C102)	Value	N	Y	Y	N
C003	Prices 3 (Repeated at address C103)	Value	N	Y	Y	N
C004	Prices 4 (Repeated at address C104)	Value	N	Y	Y	N
C005	Prices 5 (Repeated at address C105)	Value	N	N	Y	N
C006	Prices 6 (Repeated at address C106)	Value	N	N	Y	N
C007	Prices 7 (Repeated at address C107)	Value	N	N	Y	N
C008	Prices 8 (Repeated at address C108)	Value	N	N	Y	N
C009	Prices 9 (Repeated at address C109)	Value	N	N	Y	N
C010	Prices 10 (Repeated at address C110)	Value	N	N	Y	N
C011	Maximum change paid out in Multivend mode	Value	N	N	Y	N
C012	Discount award (Increase in credit when discount trigger is reached)	Value	N	N	Y	N
C013	Discount Award Trigger	Value	N	N	Y	N
C014	Exact Change Accept Group	<u>Single/Four-Price (Electromechanical)</u> Displays MDB coin type number – Coins up to and including this value will be accepted when there is an Exact Change condition.	N	Y	N	N
		<u>Executive (Protocol A):</u> Coin Value reported - Coins up to and including this value will be accepted when there is an Exact Change condition.	N	N	Y	N
C015	Single/Multivend and Cashless Revaluation	<u>Single/Four-Price (Electromechanical):</u> 0 Multi Vend Disabled 1 Multi Vend Enabled	N	Y	N	N
		<u>Executive (Protocol A):</u> <u>Card Revaluation OFF:</u> 0 Single-vend, Credit Limit 1 Multi Vend, Credit Limit 2 Single Vend, Price Limit 3 Multi Vend, Price Limit <u>Card Revaluation ON:</u> 4 Single vend, Credit Limit 5 Multit Vend, Credit Limit 6 Single Vend, Price Limit 7 Multit Vend, Price Limit	N	N	Y	N
C016	Escrow Return Inhibit	0 Coin Return Allowed 1 Coin Return NOT Allowed	N	Y	Y	N
C019	Peripheral and Clear Checksum Flag	<u>No Executive Card Reader</u> 0 Checksum OK 1 Checksum Error <u>Executive Card Reader Installed</u> 4 Checksum OK 5 Checksum Error	N	Y	Y	N
C020	Bill Value (scaled)	Value	N	Y	N	N
C021	Four Price Time out	Programmable 4-20 seconds	N	Y	N	N

# SECTION 3: CONFIGURATION

DIGITAL DISPLAY AUDIT INFORMATION CHANGER ADDRESSES				Y=Supported N=Not Supported R=Read Only		
Address	Field	Description	G	S/F	A	BDV
C022	L+ Mode Enabled	0 L Mode 1 L+ Mode	N	N	N	N
C024	L+ Programmed Left tube coin	0-15 Coins 0-12	N	N	N	N
C025	L+ Programmed Right tube coin	0-15 Coins 0-12	N	N	N	N
C026	L+ Programmed Middle tube coin	0-15 Coins 0-12	N	N	N	N
C027	Full Buffer Mode	0 Normal buffer mode	N	N	N	N
C028	L+ Fourth Tube Reporting	0 Cashbox sorting always reported	N	N	N	N
C029	Card Scale factor	Value	N	N	Y	N
C030	Max. Credit	Value	N	N	Y	N
C032	"Use Correct Change" value	Value	N	Y	Y	Y
C036	Price Hold and Display	0 Disable Price Holding 2 Enable Price Holding 3 Enable Price Holding and Price Display	N	N	Y	N
C042	Price Display Mode	0 Disable 1 Enable	N	Y	N	N
C043	Keep Change Mode	0 Disable 1 Enable	N	Y	N	N
C044	Four Price or Single Price Mode	0 Single Price Mode 1 Four Price Mode	N	Y	N	N
C045	Single Price Vend Mode	0 Pulse Vend 1 Vend Holding Until Blocker Signal	N	Y	N	N
C046	Alternate Exact Change Mode	0 Programmed Value 1 Use Highest Price Plus Highest Coin	N	Y	N	N
C047	Mode Switch Disabled	0 Mode Switch Enabled 1 Mode Switch Disabled	N	R	N	N
C048	Read Only Display (Addresses C001 through C255)	0 Changes From Digital Display Enabled 1 Changes From Digital Display Disabled	N	R	R	R
C049	Enable DEX Clear	0 DEX Clear Disabled 1 DEX Clear Enabled	N	R	R	N
C050	DEX Clear	0 DEX data is present 1 Clear DEX audit data	N	Y	Y	N
C051	MDB Bill Acceptor Exact Change Accept Group	Notes are Accepted up to and Including This Value	N	N	Y	N
C052	MDB Bill Acceptor Escrow	0 Bill Escrow Enabled 1 Bill Escrow Disabled	N	N	Y	N
C053	MDB Cashless Price Lines	0 Enabled 1 Disabled	N	N	Y	N
C054	MDB Cashless Response Delay	Programmable 5-50ms	N	N	Y	N
C055	Number of Active Price lines	Programmable 1-25	N	N	Y	N
C056	Executive Audit Peripheral Device Enable	0 Disabled 1 Enabled, Interim 2 Enabled, Total 3 Enabled, Interim and Total	N	N	Y	N
C060-C067	ID101- DEX Audit Field	Machine Identification Number	N	N	Y	N
C074-C089	Token Values	Values Assigned To Any Tokens Accepted	N	N	Y	N
C090-C097	ID104 - DEX Audit Field	Machine Location Number	N	N	Y	N
C101-C125	Protocol 'A' Price lines	25 Price Lines. The Prices Lines are used when in Price Holding mode for coin credit.	N	N	Y	N
C201-C225	Cashless Price Lines	25 Cashless Price Lines. The Prices Lines are used when a vend is carried out using credit	N	N	Y	N

# SECTION 3: CONFIGURATION

DIGITAL DISPLAY GENERAL USE ACCEPTOR INFORMATION ADDRESSES		
Display Addresses	Description	Options
A001	Select Unit Configuration, applicable to Dual Currency models only.	1 Enables and pays out coins 16-31 2 Enables coins 0-31, pays out coins 16-31 3 Enables coins 0-31, pays out coins 0-15 4 Enables and pays out coins 0-15 Note: The reported currency will be that of the coins being paid out
A002	Payout Configuration *	Used to select a standard payout configuration or for a user payout configuration. ALT options are user programmable.
A003	Tokens Enabled (If tokens are programmed)	0 Disable all tokens 1 Enable all tokens
A004	Coin Ratio (read only) *	Displays the coin values
A005	Coin Enables *	0 Coin is disabled 1 Dummy MDB coin. 2 Coin accepted, Non-compressed for MDB 3 Coin accepted, Compressed for MDB The following can only be set in the factory: 4 Slug Eater 5 Slug Eater with dummy coin 6 Credited and Returned, Non-compressed 7 Credited and Returned, Compressed
A006	Validation Acceptance Level *	Relative acceptance Levels (1-10) for all 32 coin types 1 Highest slug protection ~ 7 Factory acceptance rate ~ 10 Highest acceptance rate
A007	Float Setting - All Tubes	Each Digit Represents a Tube "A-B-C-D" 0 Float mode disabled 1 Float level set 2 Float pay-down set
A008	Float Setting - Individual Tubes*	0 Float mode disabled 1 Float level set 2 Float pay-down set
A009	Alternative Payout	0 Disable Enhanced coin payout 1 Enable Enhanced coin payout
A010	Scaling Factor	Value used to scale all coins
A011	Decimal Point Value (read only)	Value
A012	Remainder Enable Applicable to Dual Currency models only	0 Remainder disabled 1 Remainder enabled, never cleared 2 Remainder enabled, cleared at reset 3 Remainder enabled, cleared at payout 4 Remainder enabled, cleared at reset or payout

\* Indicates a sub-address is used

## SECTION 3: CONFIGURATION

---

### Changing The Coin Tubes and Coin Routing

#### REMOVING/REPLACING THE TUBES

To remove the coin tubes, remove the acceptor and then remove the grey, smoked front cover by pulling out on the left side of the cover at the notch in the housing. The front cover will swing forward, exposing the tubes. The tubes can be removed one at a time by pulling upward. Four slots have been placed in the front of the changer along the pay-out assembly area to assist in this procedure. Place a screw driver into the slot and apply an inward pressure to free the tube retainer tab whilst pulling upwards on the tube. Replace the coin tubes by inserting the dove tail guides into the tube holes and pushing inward and downward.

#### ABOUT THE SHIMS

The coin tubes in your COINCO GLOBAL2® changer utilise six interchangeable shims to accommodate variable thicknesses of coins. These shims are color-coded and are fixed to the bottom of the coin tubes. Shims are removed and replaced by sliding in or out of the bottom of the coin tube.

*NOTE: Do not reuse shims. Installation and removal can stress the plastic, causing the shims to lose their ability to stay firmly in place.*

#### CHANGING THE COIN ROUTING

After changing the coin tubes, the coin routing needs to be reconfigured via the Digital Display using Address “A002”.

This address allows the user to change payout configuration in the field. This feature only provides a means for the acceptor to alter coin routing when different physical payout tubes have been placed in the changer body.

When address A002 is entered five payout configurations are available. Selection is achieved by scrolling up (button B) or down (button D) to the desired configuration. When the desired setting is reached, press enter (button C) to store the selection. The far right decimal point will illuminate to indicate the setting has been stored to memory. If the location has the capability of being programmable (Display shows Alt1 for example) pressing enter (button C) again will enter programmable mode. This will be evident if a value between “a” and “e” is displayed.

To program a coin to a tube, select the tube by scrolling to the desired tube, (‘a’ is the first tube on the left) and drop the coin type to be routed to the tube. If a coin’s value differs from the coins currently routed to the tube, all coins previously routed to the tube with different values will be rejected. If value “e” is chosen for a new destination, the coin type dropped will have its routing changed to the cashbox. Pressing enter (button C) again will return to the second sub address menu, esc (button A) will always return to the high level address selection menu.

For correct operation the scaling factor should be equal to the value of the least coin accepted. E.g. if the least value coin accepted is the GBP 10p after altering the payout configuration the scaling factor in address A010 should be changed to 10.

Float modes will be turned off and coin counts will be cleared for any tube in which all coins assigned to the tube were not previously assigned to the tube and have been assigned during the current payout configuration session.

## SECTION 3: CONFIGURATION

---

### Example of changing the predefined coin routings.

To configure the coin tubes via the Digital Display, follow these steps:

1. Enter the Display Mode (see “Display Mode” section of this manual).
2. Press B to scroll up to the Address “A002”
3. Press C to enter the Address.
4. Use buttons B (increase) or D (decrease) to change selection to “802”.
5. Press C to enter the new routing information. The far right decimal point will illuminate to indicate the selection has been stored.
6. Press A to return to the Address Display.
7. Press A to exit the Display Mode. The payout configuration has been changed to “802”.

*EXAMPLE: The COINCO GLOBAL® changer is configured as follows:*

*Coin Type 0 goes to Tube A*

*Coin Type 1 goes to Tube B*

*Coin Type 2 goes to Tube C*

*Coin Type 3 goes to Tube D*

*Remaining Coin Types 4-15 go to Cashbox.*

*BUT, Coin Type 6 is interchangeable with coin type 0 and must be accepted to Tube A along with coin type 0...*

### Example of setting up user defined coin routing.

1. Enter the Display Mode.
2. Press B to scroll up to Address “A002”.
3. Press C to enter the Address.
4. Press B (increase) or D (decrease) to choose one of the programmable payout configuration selections.
5. Press C to select the payout configuration.
6. Press C again to enter programmable payout configuration mode. The display will be shifted to the far left.
7. Use button B and D to choose tube A (“A” on the display) then drop one of coin type 0 and one of coin type 6.
8. Select tube B, drop one of coin type 1.
9. Select tube C and drop one of coin type 2.
10. Finally, Select tube D drop one of coin type 3.
11. Verify all coins have been routed to the desired tubes.
12. Press A to return to address menu
13. Press A again to exit. The payout configuration has now been changed to:

*Coin Type 0 goes to Tube A and cashbox*

*Coin Type 1 goes to Tube B and cashbox*

*Coin Type 2 goes to Tube C and cashbox*

*Coin Type 3 goes to Tube D and cashbox*

*Coin Type 6 goes to Tube A and cashbox*

*Coin Types 4,5 and 7-15 go to Cashbox only*



## SECTION 4: MAINTENANCE

### Routine Maintenance

Routine maintenance will improve performance and extend the working life of your COINCO GLOBAL2® changer and reduce the need for more involved repairs. Frequency of maintenance will depend on environment and number of transactions. For normal environments, cleaning is recommended every six months. However, in harsh environments with lots of dirt and dust, cleaning is recommended every three months.

The coin changer should be kept in its original shipping carton when not in use. This will keep the changer clean and offer the best protection for the unit.

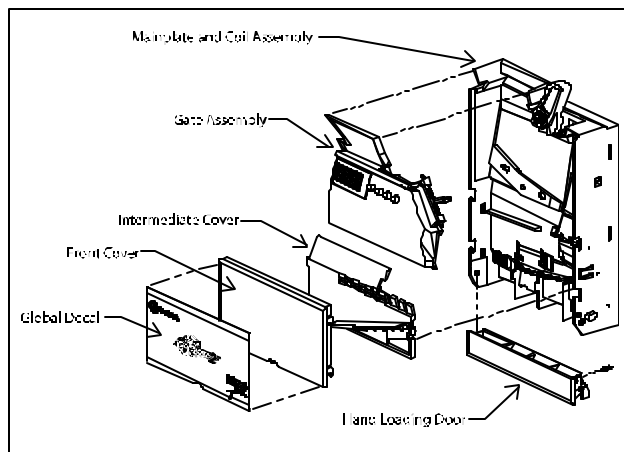


Figure 12

### Cleaning

A majority of your COINCO GLOBAL2® changer is manufactured from a high-quality plastic, which should only be cleaned with a warm water and mild detergent solution.

- CAUTION:
- Never submerge unit in water.
  - Do not use petroleum solvents, steel wool, scouring pads, or a metal brush for cleaning.
  - Do not spray any part of the changer with any type of lubricant.

Since all coins share a common coin ramp, heavy usage or a dirty environment can result in dirt build-up. To clean the coin ramp, lift the acceptor gate upward and diagonally to the right. Hold gate to prevent it from snapping back. Wipe the exposed coin ramp and inner surface with a damp cloth, being cautious not to harm the coin stabilizer (a thin piece of polyester film). If the coin stabilizer looks buckled, wrinkled or is not firmly adhered to the changer, replace it at this time.

*NOTE: Not all COINCO GLOBAL2® changers are equipped with a coin stabilizer.*

For detailed cleaning of the acceptor, remove the front cover by opening the coin tube loading door and wedging thumb underneath front cover. To remove cover, push out and up. Next, remove the intermediate cover by depressing snap on right side and pivot intermediate cover away from unit. You are now able to fully clean both the intermediate cover (paying particular attention to the mirrored surface), as well as the interior coin rail and gates. (Use caution when removing the metal debouncer. Due to its small size, it can be easily misplaced.) Reassemble front of acceptor in reverse order of disassembly.

## SECTION 4: MAINTENANCE

---

### Removing/Replacing Individual Modules

Modular assembly replacement provides the basis of all COINCO GLOBAL2® series changer repair. Instructions for removing and replacing modules are provided below. These modules should be removed in the following sequence:

#### ACCEPTOR

To remove the acceptor from the changer, release the acceptor latch and pull the top of the acceptor forward, away from the changer. Unplug ribbon cable from changer. Free lower acceptor studs from changer housing.

#### UPPER TUBE SENSE BOARD

Remove the grey, smoked front cover by pulling out on the left side of the cover at the notch in the housing. The front cover will swing forward, exposing the tubes. Remove the four inventory tubes one at a time by pulling upward. Remove strain relief bracket, which is located in the upper left corner of changer housing, by removing screw. Remove recessed screw that secures logic board cover and remove cover. Push snap toward top of housing and remove upper tube sense board (which will separate from main logic board upon removal).

#### PAYOUT BASE

Disconnect the two motor harnesses and the tube sense harness. Remove the screws from the bottom, exterior sides of the changer housing and remove payout base.

#### MAIN LOGIC BOARD ASSEMBLY

Unplug harnesses from logic board and lift the logic board out of the housing.

### Clearing Coin Jams

Should a coin jam occur in the cashbox chute area, use the following steps to help dislodge coins:

1. Remove changer from vendor.
2. Keeping changer in an upright position, remove cashbox chute (located on the back of the changer) by pulling lower edge out and down at the same time.
3. Remove any lodged coins.
4. Replace the cashbox chute by pressing in and up to snap into place.

# SECTION 5: TROUBLESHOOTING

---

## Error Codes

If any of the errors listed below as “E001-E007” are detected the message “Error” will flash on the display. To view the error or a list of errors enter the Display Mode (see “Display Mode” section of this manual). If a single error is detected the code will be displayed in place of the “Full/Fill AbCd” message. If there is more than one error, the codes will alternate one after the other.

“FULL/FILL AbCd” ..... No Errors  
“E001” ..... Validation Sensors Error  
“E002” ..... Tube Sensors Error  
“E003” ..... Coin Jammed  
“E004” ..... Payout Error  
“E005” ..... ROM Error  
“E006” ..... Configuration Error  
“E007” ..... Supply Voltage Error

The error codes listed below are displayed upon occurrence:

“E 20” ..... Double Arrival  
..... (coins dropped too fast)  
“E 88” ..... A Payout sweeper arm is at the  
..... end of stroke, re-align the sweeper arm.  
“E 82” ..... VMC attempting to pay out  
..... coins from an empty tube

The following errors will require the changer to be sent to a Coinco service centre for repair:

“E 21” ..... A to D Conversion fault  
“E 22” ..... Validation Opto Fault  
..... or jammed coin in validation path  
“E 25” & “E 26” ..... EC coil reading timeout  
“E 27” & “E 28” ..... MF coil reading timeout  
“E 29” ..... Stored air values corrupt  
“E 40” ..... TAU coil failure  
“E 41” ..... EC coil failure  
“E 42” ..... MF coil failure  
“E 90” ..... Acceptor memory failure

# SECTION 5: TROUBLESHOOTING

## Diagnostics

When the coin return lever is depressed or a coin is dropped, both the decimals points (Figure 13) and the four digits (Figures 14 and 15) are used to communicate various diagnostic conditions as shown:

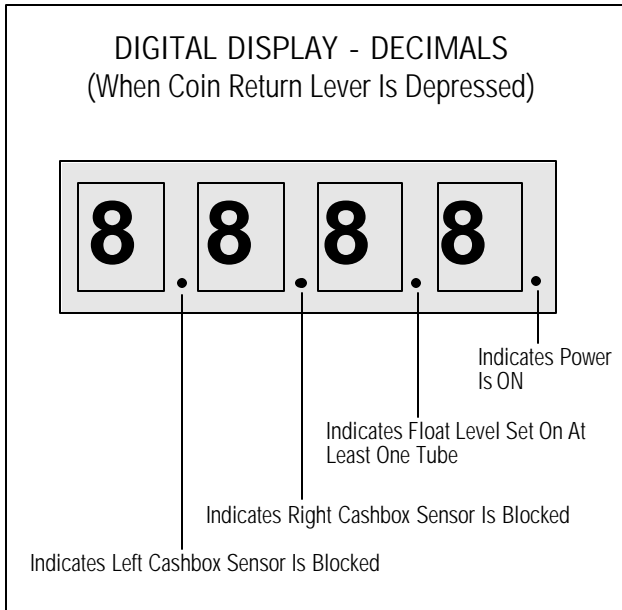


Figure 13

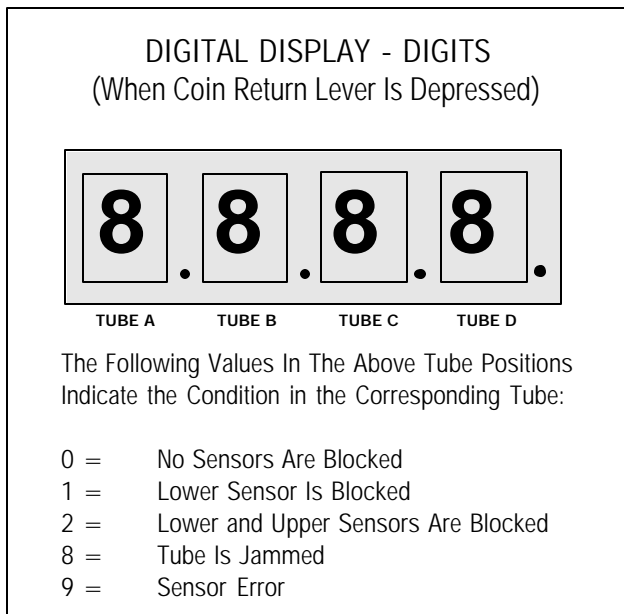
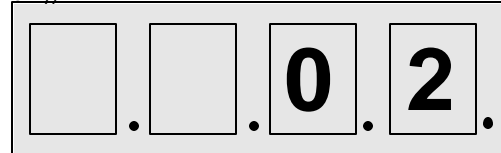


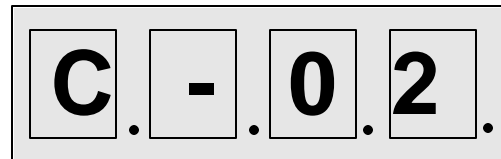
Figure 14

**DIGITAL DISPLAY - DIGITS**  
(When Coin Is Inserted)

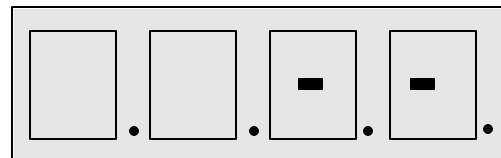
The Following Values In The Following Positions Indicate a Response to the Coin that was Just Dropped (the digit "2" is used for example purposes only):



2 = Coin Type Recognized and Credited



-2 = Coin Type Recognized but Not credited\*



-- = Coin Type Not Recognized

\*Note: One of the following letter codes may appear in lieu of the "C"

- n An attempt has been made to route, however the coin was not sensed at the credit allocation sensors
- C Rejected as controller has disabled acceptance of the MDB coin type associated with this coin or error in routing due to cashbox sensor being blocked
- d Rejected as coin has been disabled by the acceptors internal coin enable settings
- U Rejected as the coins value is too large to enable coin's acceptance or the value is too small and the remainder system is disabled
- t Rejected as the coin set associated with this coin is not enabled

Figure 15

## SECTION 5: TROUBLESHOOTING

<b>Troubleshooting Guide</b>			
<b>TROUBLE</b>	<b>POSSIBLE CAUSE</b>	<b>PROCEDURE</b>	<b>REMEDY</b>
No coin acceptance	<p>No power</p> <p>Acceptor</p> <p>Low Power.</p> <p>Vend price is set to 0.</p>	<p>Make sure changer is plugged into vendor.</p> <p>Check power/blocker LED behind acceptor. (Four Price Only.) If LED is on, replace acceptor.</p> <p>If still no coin acceptance,</p> <p>If still no coin acceptance,</p> <p>If LED is off, check to see that acceptor cable and changer power harness are properly connected to changer's main logic board.</p> <p>If still no coin acceptance,</p> <p>If still no coin acceptance,</p> <p>Flashes "20" on display when coin is dropped.</p> <p>Set vend price (see "Setting the Vend Price" sections of this manual.</p>	<p>Plug changer into into vendor.</p> <p>Replace acceptor.</p> <p>Replace changer's main logic board.</p> <p>Replace changer's main power harness.</p> <p>Plug acceptor cable and/or changer power harness into changer main logic board.</p> <p>Replace changer's main logic board.</p> <p>Replace changer's main power harness.</p> <p>Check power source.</p>
No Coin Acceptance or Rejects Percentage of Good Coins	<p>Coin Return Lever</p> <p>Acceptor is dirty or foreign matter in coin accept path</p>	<p>Make sure changer is mounted correctly and coin return lever is in proper position</p> <p>Check to see that acceptor coin path is clean and free of matter</p> <p>If still rejects good coins,</p> <p>If still rejects good coins,</p>	<p>Reposition changer and/or vendor coin return lever.</p> <p>Clean acceptor and remove any foreign matter.</p> <p>Replace acceptor.</p> <p>Replace changer's main logic board .</p>
Accepts Coins But Gives No/Or Erratic Credit	Acceptor	<p>Replace acceptor with good acceptor and test to see if changer functions properly.</p> <p>If still no/erratic credit,</p> <p>If still no/erratic credit,</p>	<p>Replace defective acceptor.</p> <p>Replace changer's main logic board.</p> <p>Replace changer's main power harness.</p>

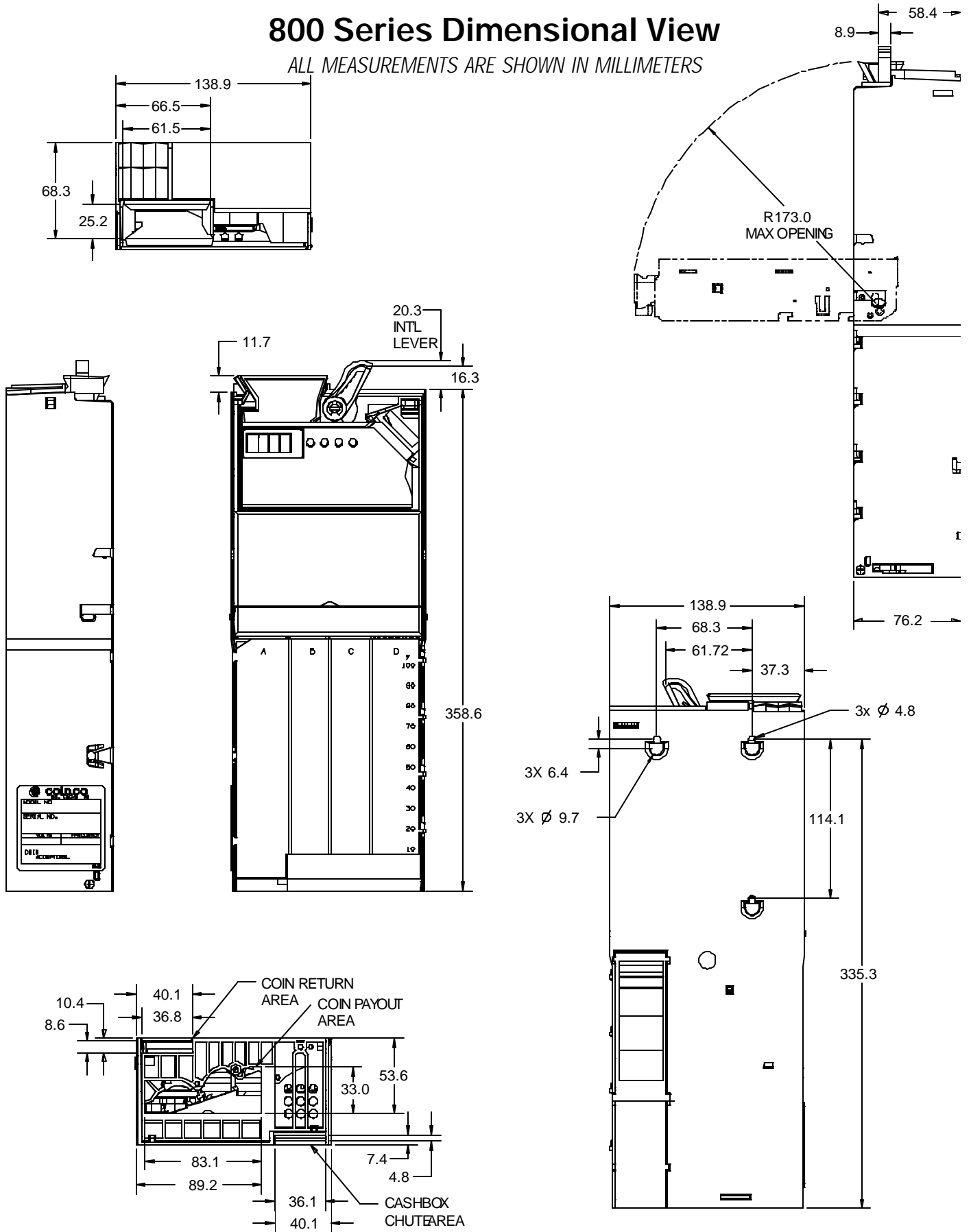
## SECTION 5: TROUBLESHOOTING

Troubleshooting Guide			
TROUBLE	POSSIBLE CAUSE	PROCEDURE	REMEDY
Accepted Coins Always Go To Cashbox	Coin Routing  Tube Sensor Board or Acceptor	Check that coins are routed to tubes.  Check the sensor board for loose components. Make sure tube sensor board is properly secured to main logic board. Check cable from sensor board for damage or improper connection.  If coin still goes to cashbox, replace acceptor with good acceptor and test to see if changer functions properly.  If coin still goes to cashbox,	See "Rerouting the Coins."  Replace tube sensor board.  Replace acceptor.  Replace changer's main logic board.
Accepted Coins Always Go To Coin Tubes	Coin tube gate is in the open position  Tube Sensor Board	Remove acceptor back cover and check solenoid for free operation.  Replace tube sensor board with good board and test to see if changer functions properly.  If coins still go to tubes,	Replace acceptor.  Replace tube sensor board.  Replace changer's main logic board.
Changer Credits Coins But Does Not Escrow	Coin return lever  Acceptor  Switch 9 is ON - escrow is inhibited.	Make sure changer is mounted correctly and acceptor gate opens when vendor coin return lever is operated.  Replace acceptor with good acceptor and test to see if changer operates correctly.  Uninhibit the escrow feature.	Reposition changer and/or vendor coin return lever.  Replace defective acceptor.  Turn switch 9 OFF and press the Mode Switch.
No Payout	Payout Motor	Make sure motor wires are properly connected to changer's main logic board.  If still no payout, replace motor with good motor and test to see if changer operates properly.	Plug motor wires into logic board.  Replace defective payout motor.

# SECTION 6: EXPLODED VIEWS

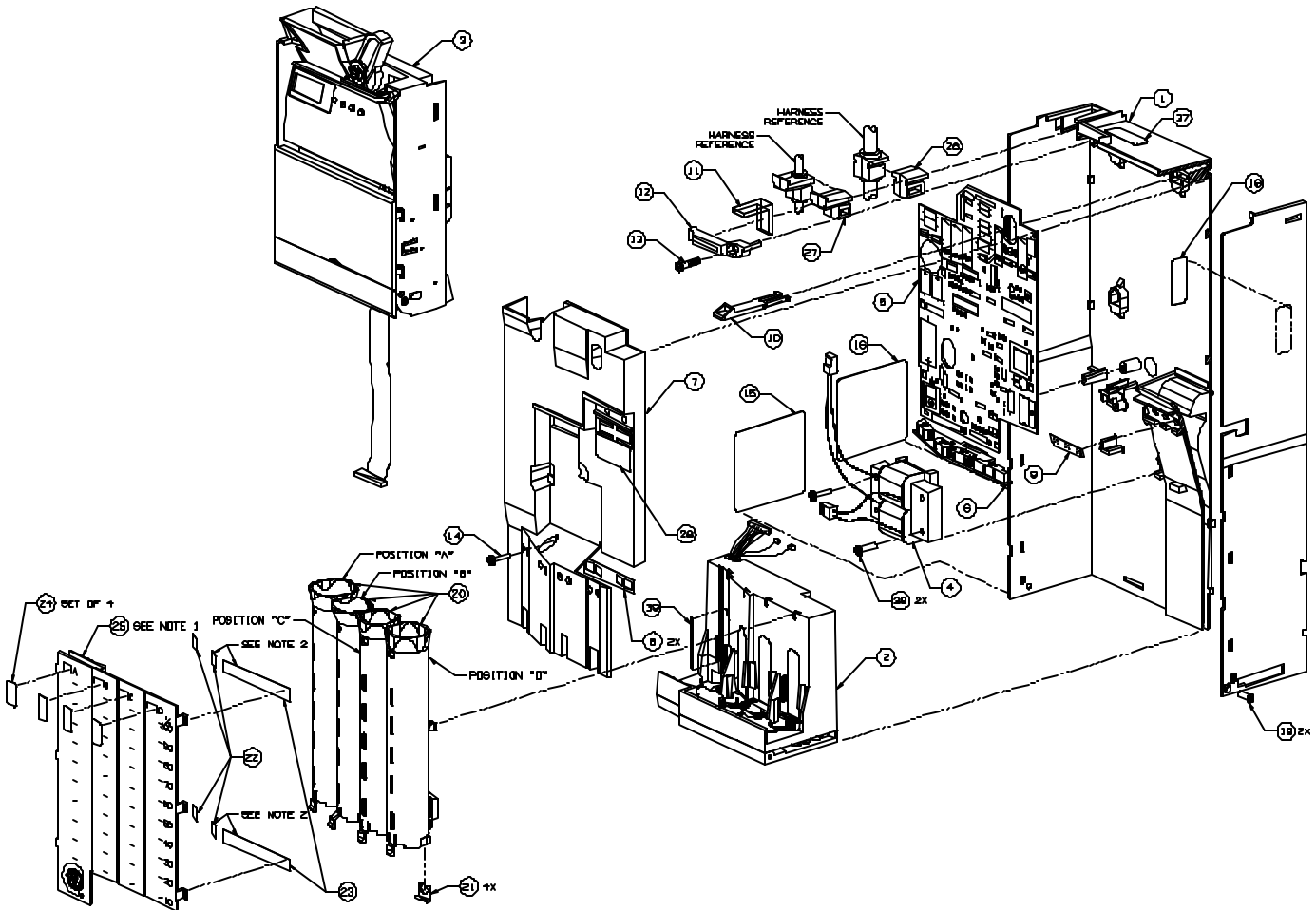
## 800 Series Dimensional View

ALL MEASUREMENTS ARE SHOWN IN MILLIMETERS



# SECTION 6: EXPLODED VIEWS

## 800 Series Final Assembly

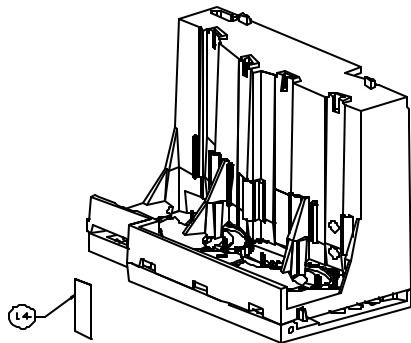


ITEM NO.	DESCRIPTION	ITEM NO.	DESCRIPTION
1	Assembly, Housing	17	Harness, Bill Validator (optional, selective models)
2	Assembly, Payout	18	Label, Configuration
3	Assembly, Acceptor	19	Screw, Flat Head #4 x 5/16
4	Assembly, Transformer (F/S models only)	20	Tube, Inventory
5	Logic Board	21	Shim
6	Board, Upper Tube Sense	22	Mirror, Tube A
7	Cover, Logic Board	23	Mirror, Tube C and D
8	Lens, Upper Tube Sense	24	Labels, Tube
9	Lens, Cashbox	25	Front Cover/Coin Return
10	Latch	26	Plug, Lg. Strain Relief (selective models)
11	PVC Foam	27	Plug, Sm. Strain Relief (selective models)
12	Bracket, Strain Relief	28	Label, Price Setting (F/S models only)
13	Screw, Pan Head #6 x 11/16	--	
14	Screw, Pan Head #6 x 1/2	37	Label, Warranty (selective models)
15	Label, Identification	38	Screw, Pan Head #4 x 3/4
16	Label, Patent	39	Pad (selective models)

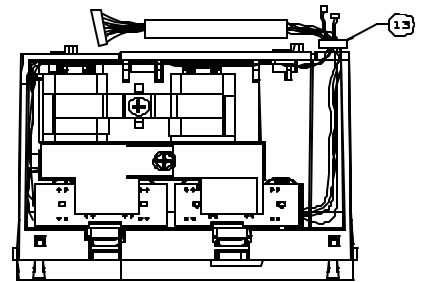


# SECTION 6: EXPLODED VIEWS

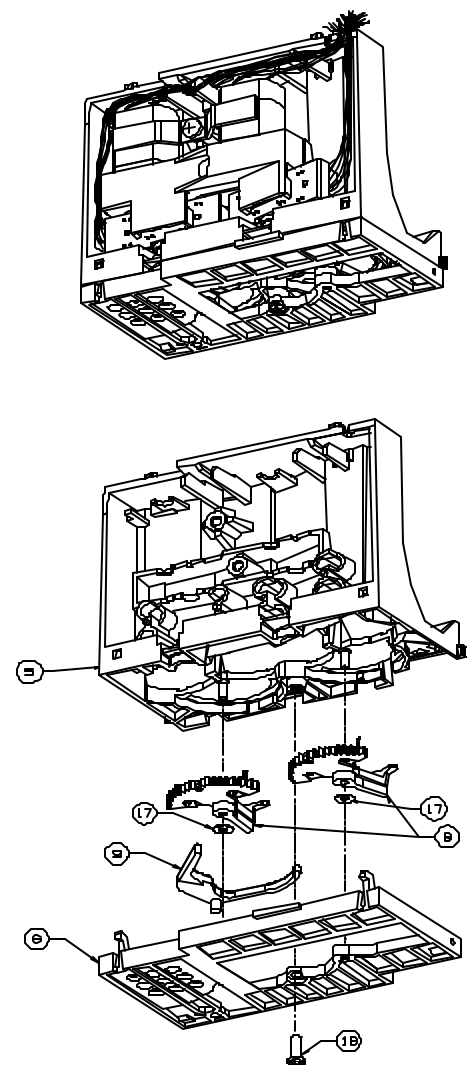
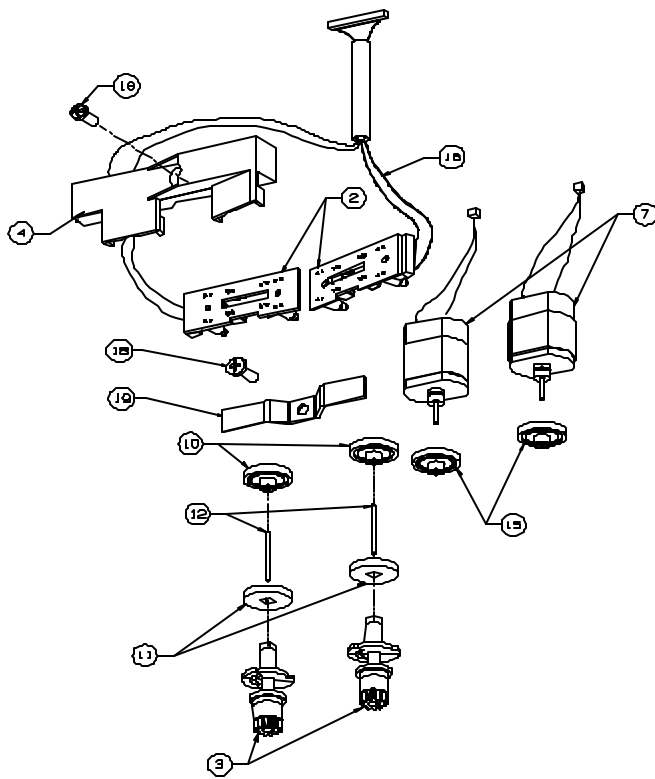
## 800 Series Payout Base Assembly



FRONT VIEW



BACK VIEW



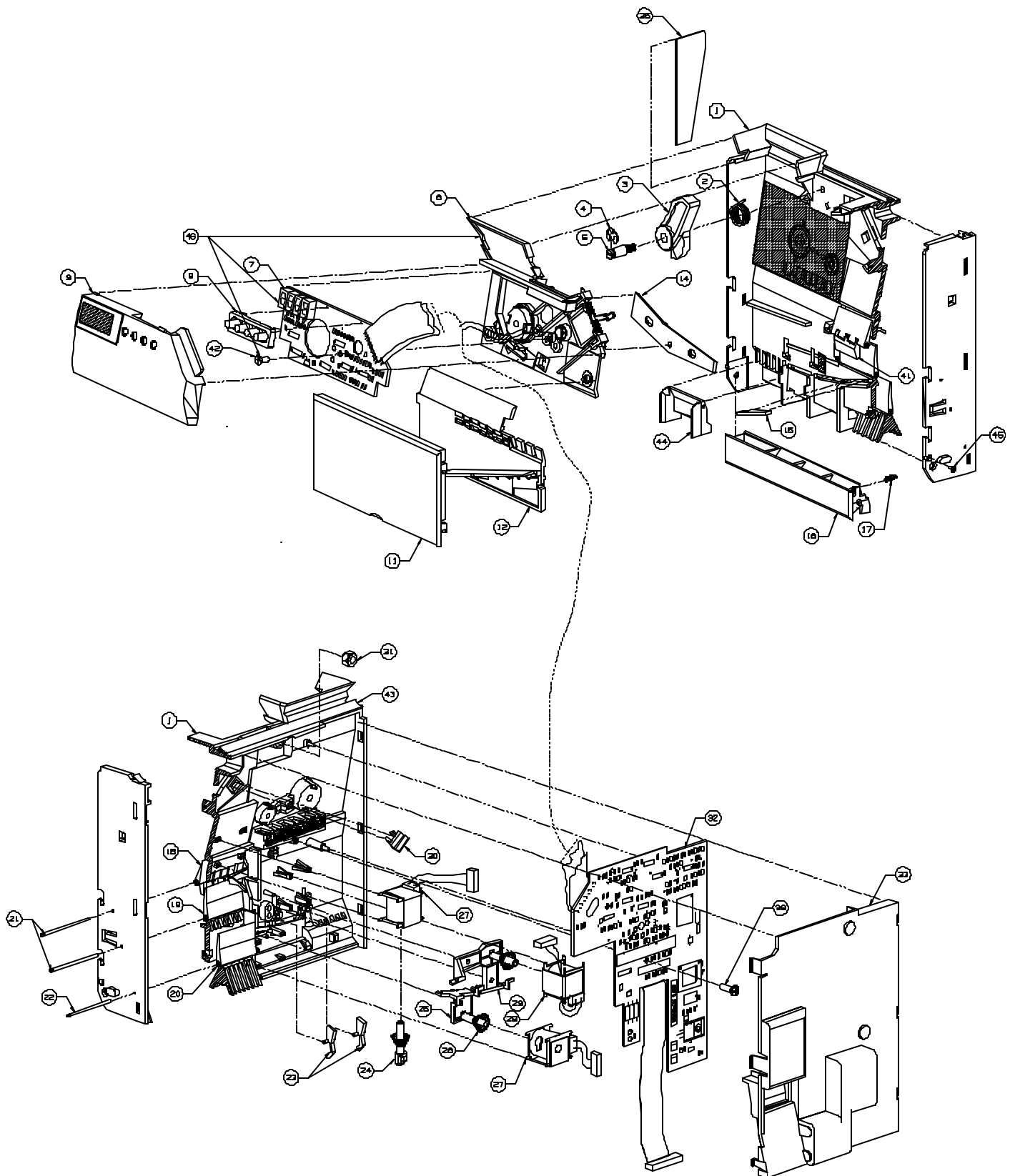
ITEM NO.

DESCRIPTION

1	Removed		
2	Tube/Home Sense Board-Lower		
3	Gear, Encoder		
4	Cover, Gearbox		
5	Base, Payout-Upper		
6	Base Payout-Lower		
7	Assembly, Motor/Harness		
8	Assembly, Sweeper		
9	Arm, Coin Clearing		
10	Gear, Reduction		
11	Gear, Pinion		
12	Shaft, Gear		
13	Cable Tie		
		14	Lens, Tube Sense-Lower
		15	Gear, Reduction
		16	Harness, Lower Tube Sense
		17	Washer, Plastic (selected models only)
		18	Screw, 8x1/2 PH, PHL, Threadcutting
		19	Retainer, Motor

# SECTION 6: EXPLODED VIEWS

## 800 Series Acceptor Assembly



# SECTION 6: EXPLODED VIEWS

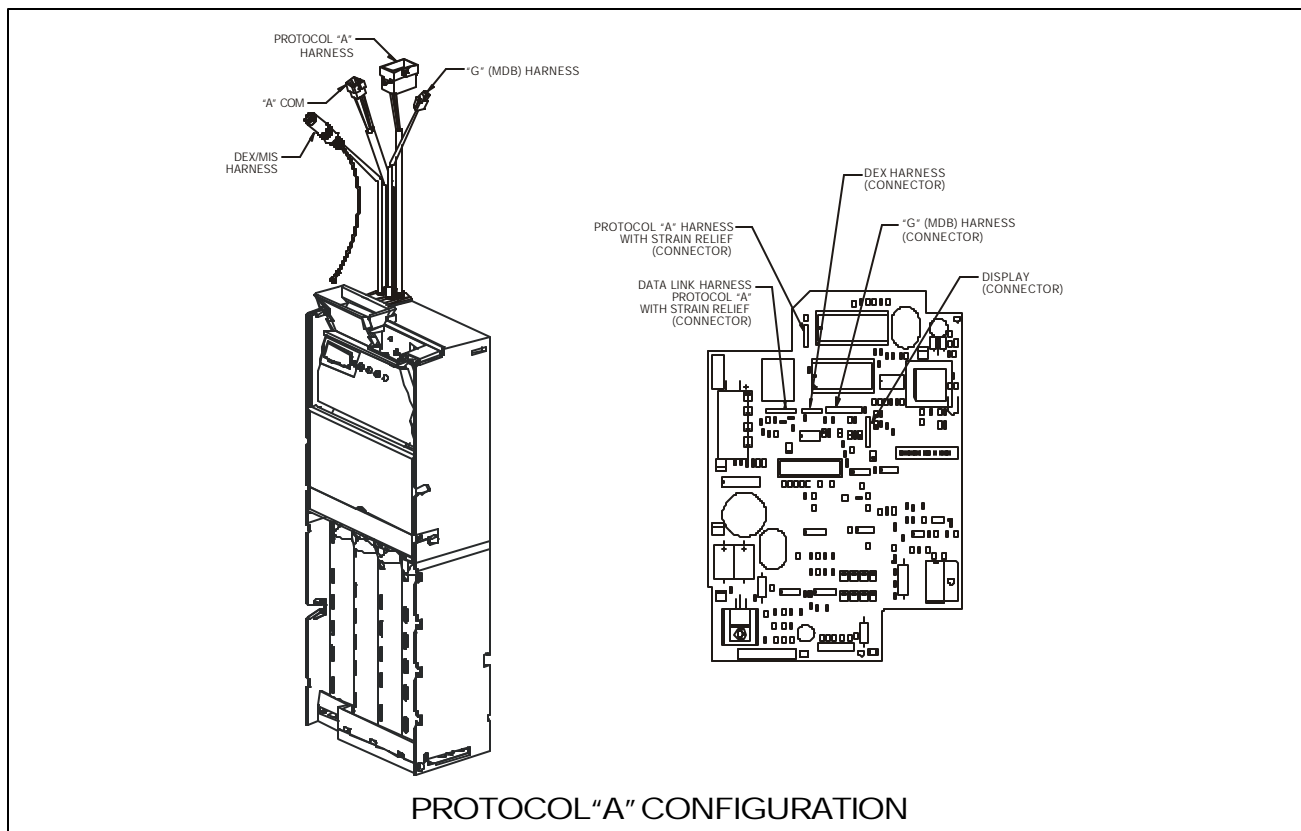
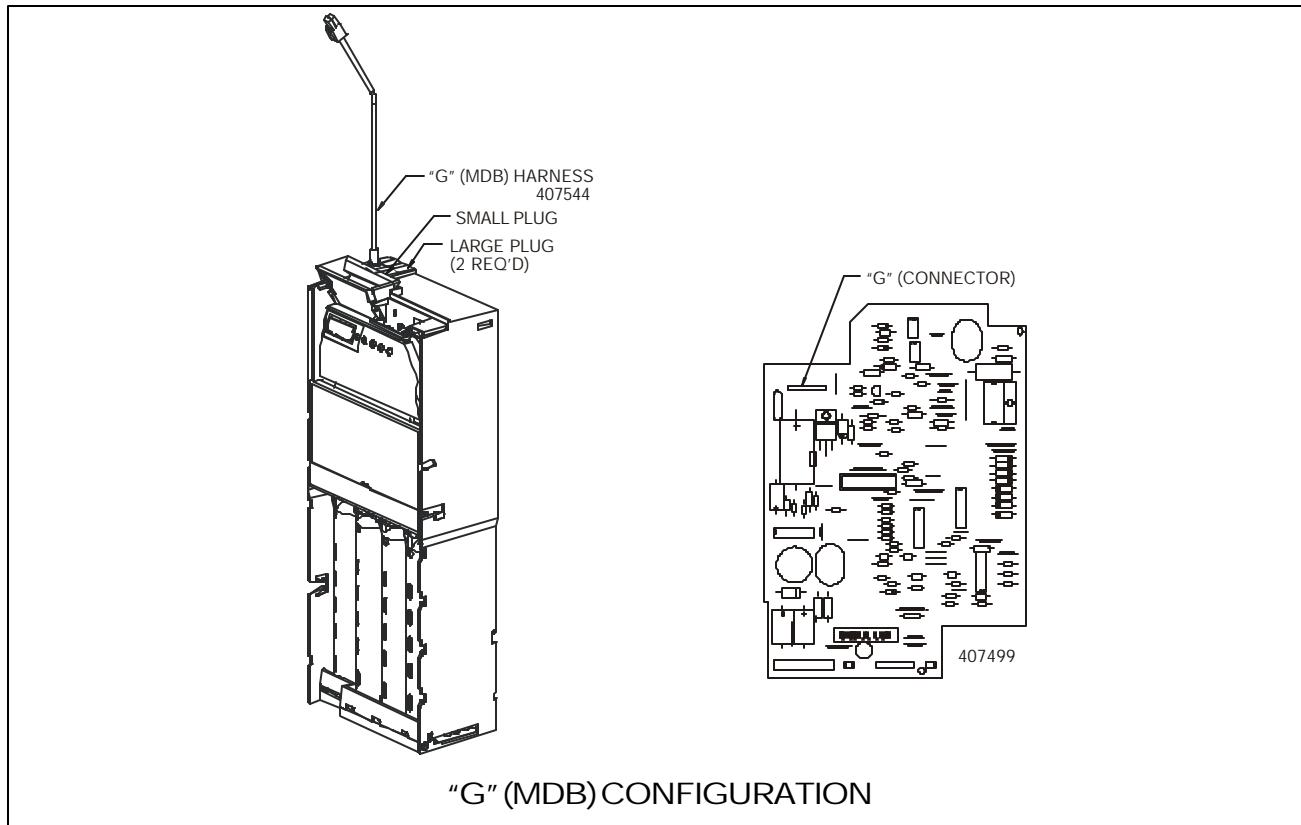
---

## 800 Series Acceptor Assembly

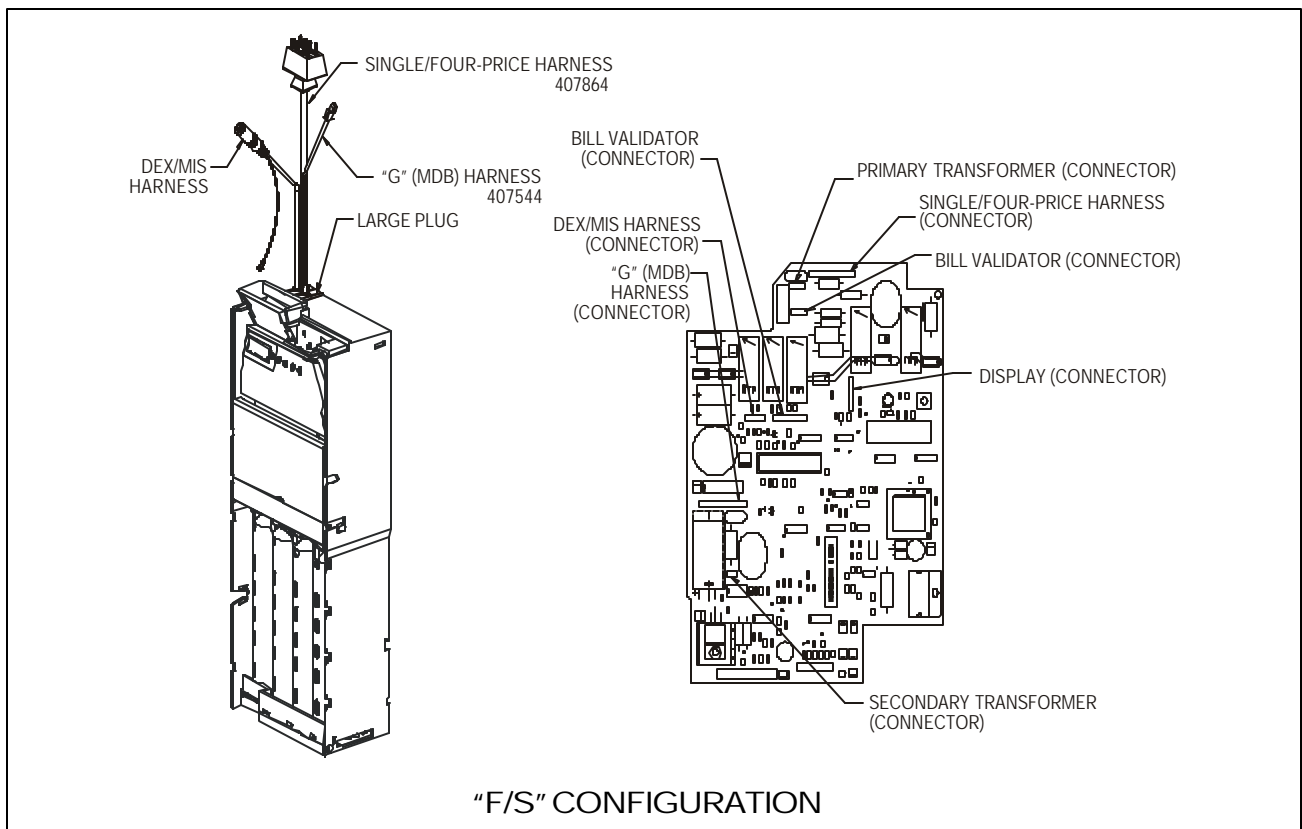
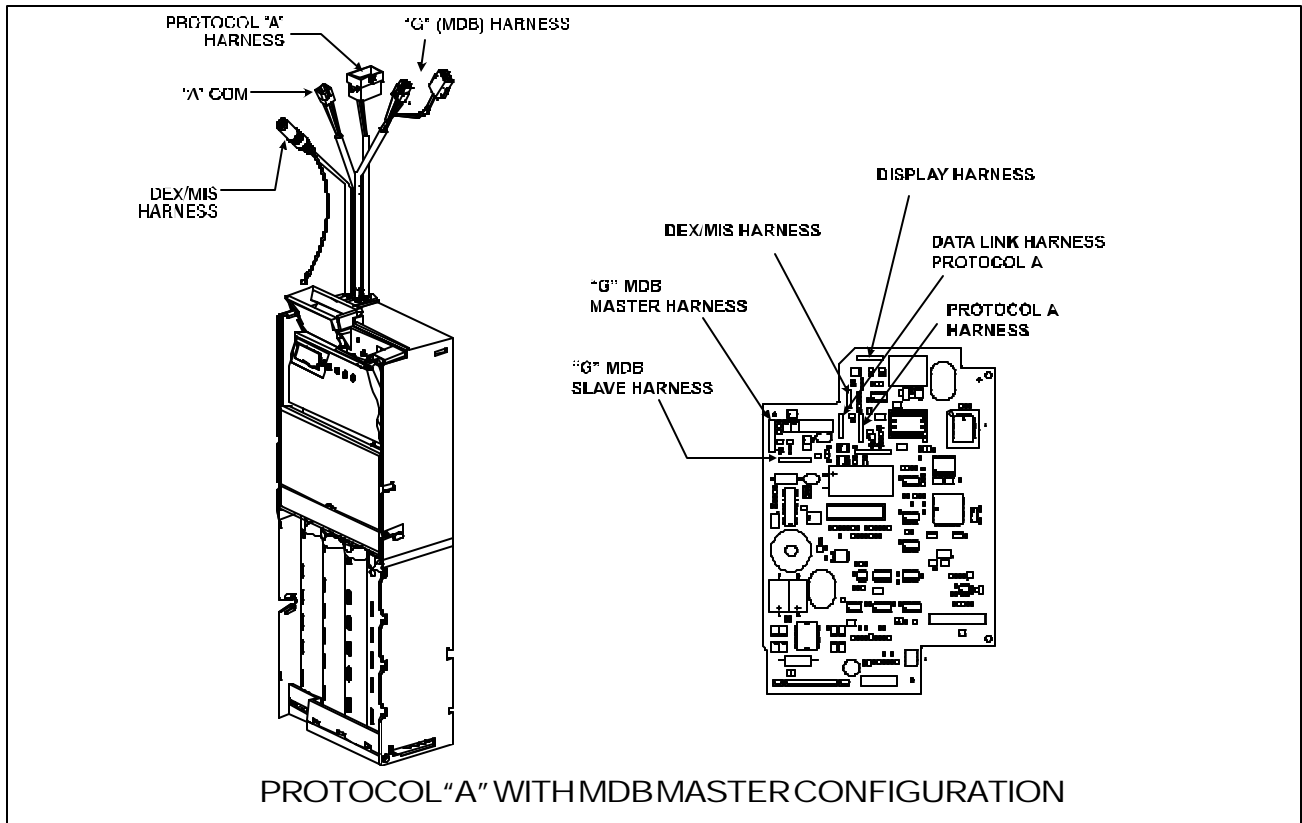
<u>ITEM NO.</u>	<u>DESCRIPTION</u>
1	Mainplate and Coil
2	Operating Lever Spring
3	Operating Lever
4	Retaining Ring
5	Gate Lever Pivot Screw
6	Gate and Coil Assembly
7	Gate Board
8	Keypad
9	Gate Cover
10	Label
11	Front Cover
12	Intermediate Cover
13	Label, Mirror .575
14	Debounce, Validation
15	Debounce, Sorting
16	Hand Loading Door
17	Hand Loading Door Spring
18	Accept/Reject Door
19	Sort Door
20	Cashbox Door
21	Pivot Diverter Pin
22	Short Diverter Pin
23	Coin Stop
24	Plunger and Yoke Assembly
25	Tube "C" and Plunger Assembly
26	Copper Plated Spring
27	Solenoid Coil Assembly
28	"C" Frame Solenoid
29	Tube "B" and Plunger Assembly
30	Spring Retention Plug
31	Self Locking Hex Nut
32	Logic Board
33	Rear Cover
34	Acceptor Label
35	Debounce Plate
36	Patent Label
37	Foam (not shown)
38	Foam (not shown)
39	Screw, Pan Head #4x5/16
40	Global Decal
41	Anti-Stringing Lever
42	Screw, Flat Head #4x5/16
43	Acceptor Gasket
44	Insert, Mainplate (selective models only)
45	Screw, Flat Head #2x3/16 (selective models only)
46	Gate/Board assembly (for service only)

# SECTION 6: EXPLODED VIEWS

## 800 Series Harness and Logic Board Configuration



# 800 Series Harness and Logic Board Configuration



COIN ACCEPTORS, INC. PRODUCTS ARE PATENTED, AND PATENTS ARE PENDING,  
IN THE UNITED STATES AND THROUGHOUT THE WORLD.



Coin Acceptors, Inc.  
World Headquarters  
300 Hunter Avenue  
St. Louis, MO 63124-2013  
Phone: (314) 725-0100

Coin Acceptors Europe Ltd.  
4 The Felbridge Centre  
Imberhorne Lane, East Grinstead  
W. Sussex RH19 1XP England  
Phone: 44-(0)1342-315724  
Email: europe@coinco.com

Website: [www.coinco.com](http://www.coinco.com)



Coinco Publication No. 924242      Rev. 4  
01/2005      Printed in the U.S.A.