

**VIKING
PUMP**

TECHNICAL SERVICE MANUAL

INDUSTRIAL ROTARY LOBE PUMP
MODEL RL41507

SECTION	TSM 270
PAGE	1 OF 10
ISSUE	F

CONTENTS

Safety Information	1
Introduction	1
Special Information	4
Maintenance	4
Suggested Repair Tools	5
Disassembly	5
Cartridge Seal	6
Labyrinth Seal	7
Assembly	7
Thrust Bearing Adjustment	8
Installation of PEEK® Bushings	9
Warranty	12

TABLE OF ILLUSTRATIONS

RL41507 Pump Assembly	1
Exploded Pump Parts View	2
Pump Rotation	4
Head Removal	5
Timing Gear Removal	5
Use Of Bearing Puller	6
Bracket Removal	6
Fluidtec P/S®-II Cartridge Seal	6
Lobe Positioning	7
Bearing Housing Assembly	7
Timing Gear Positioning	7

INTRODUCTION

The illustrations used in this manual are for identification purposes only and cannot be used for ordering parts. Obtain a parts list from the factory or a Viking representative. Always give a complete name of part, part number and material with the model number and serial number of pump when ordering repair parts. The unmounted pump or pump unit model number and serial number are on the nameplate. This manual deals only with Viking Rotary Lobe Pumps. Specifications and recommendations are listed in Catalog Section 270.

PEEK® is a trademark of Victrex PLC.



FIGURE 1
MODEL RL41507

DANGER!

Incorrect installation, operation or maintenance of equipment may cause severe personal injury or death and/or equipment damage.

This information must be read fully before beginning installation, operation or maintenance and must be kept with the pump. It is suggested that suitably trained or qualified persons perform all installation and maintenance procedures.

DANGER !

Before opening any Viking pump liquid chamber (pumping chamber, reservoir, etc.) be sure:

1. That any pressure in the chamber has been completely vented through the suction or discharge lines or other appropriate openings or connections.
2. That the driving means (motor, turbine, engine, etc.) has been "locked out" or made non-operational so that it cannot be started while work is being done on pump.
3. That you know what liquid the pump has been handling and the precautions necessary to safely handle the liquid. Obtain a material safety data sheet (MSDS) for the liquid to be sure these precautions are understood.
4. That the timing gearbox to cool before handling the pump. The oil will become very hot during normal operation. Allow the timing gearbox oil.

Failure to follow above listed precautionary measures may result in serious injury or death.

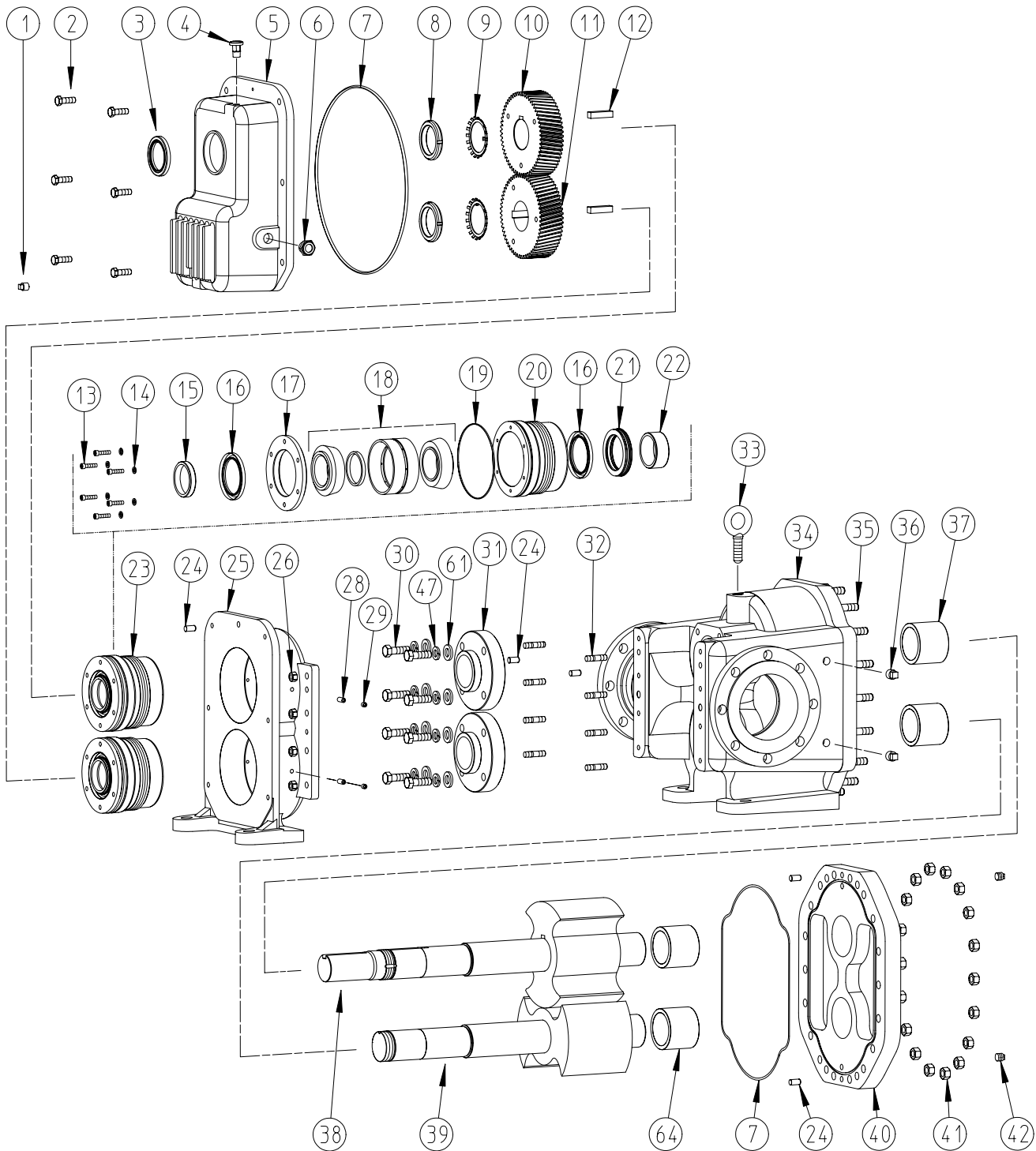

FIGURE 2 EXPLODED PARTS VIEW

TABLE 1 RL41507

ITEM	DESCRIPTION	ITEM	DESCRIPTION
1	Magnetic Drain Plug for Gear Case	24	Dowel Pin, (5 Req'd)
2	Capscrew for Gear Cover	25	Bracket
3	Lipseal for Gear Box Cover	26	Nut 1/2" NC for Bracket, (8 Req'd)
4	Breather	28	Setscrews for Bearing Housing, (4 Req'd)
5	Gear Case Cover	29	Pipe Plug for Bearing Housing, 1/8", (4 Req'd)
6	Sight Glass	30	Capscrew for Seal, 5/8", (8 Req'd)
7	Gear Case Cover, or Head O-ring	31	Cartridge Lipseal, (2 Req'd)
8	Locknut TN-14, (2 Req'd)	32	1/2" Stud for Bracket, (8 Req'd)
9	Lockwasher TN-14, (2 Req'd)	33	Lifting Eye
10	Timing Gear for Driver Shaft	34	Casing/Bushing Assembly
11	Timing Gear for Driven Shaft	35	5/8" Stud for Head, (18 Req'd)
12	Key, Special	36	1/2" Pipe Plugs, to Casing, (4 Req'd)
13	Capscrew for Bearing Housing Assembly, (12 Req'd - 6 for each Bearing Housing Assembly)	37	Casing Bushings (2 Req'd)
14	Lockwasher for Bearing Housing Assembly, (12 Req'd - 6 for each Bearing Housing Assembly)	38	Lobe/Shaft Assembly, Driver
15	Outer Bearing Spacer, (2 Req'd - 1 for each Bearing Housing Assembly)	39	Lobe/Shaft Assembly, Driven
16	Lipseal for Bearing Housing, (4 Req'd - 2 for each Bearing Housing Assembly)	40	Head/Bushing Assembly
17	Endcap for Bearing Housing, (2 Req'd - 1 for each Bearing Housing Assembly)	41	Nut, 5/8" for Head, (18 Req'd)
18	Double Tapered Roller Bearing, (2 Req'd - 1 for each Bearing Housing Assembly)	42	Pipe Plug, 1/4", to Head (2 Req'd)
19	O-ring for Bearing Assembly, (2 Req'd - 1 for each Bearing Housing Assembly)	47	Lockwasher for Seals, (8 Req'd)
20	Bearing Housing, (2 Req'd - 1 for each Bearing Housing Assembly)	61	Washer for Seals, (8 Req'd)
21	Labyrinth Seal, (2 Req'd - 1 for each Bearing Housing Assembly)	64	Bushings for Head, (2 Req'd)
22	Inner Bearing Spacer, (2 Req'd - 1 for each Bearing Housing Assembly)	not illus.	Pipe Plug 1/8", (2 Req'd), see page 2
23	Bearing Housing Assembly, Includes Items 13-22, (2 Req'd)	not illus.	Bearing Housing Spanner Wrench

TABLE 2 Torque Specifications

Item Number	2	8	13	26	28	30	41
RECOMMENDED TORQUE (ft-lb)	75	600	18	75	8 (100 in-lb)	15	75

SPECIAL INFORMATION

DANGER !

Before opening any Viking pump liquid chamber (pumping chamber, reservoir, etc.) be sure:

1. That any pressure in the chamber has been completely vented through the suction or discharge lines or other appropriate openings or connections.
2. That the driving means (motor, turbine, engine, etc.) has been "locked out" or made non-operational so that it cannot be started while work is being done on pump.
3. That you know what liquid the pump has been handling and the precautions necessary to safely handle the liquid. Obtain a material safety data sheet (MSDS) for the liquid to be sure these precautions are understood.
4. That the timing gearbox to cool before handling the pump. The oil will become very hot during normal operation. Allow the timing gearbox oil.

Failure to follow above listed precautionary measures may result in serious injury or death.

ROTATION

Refer to figures 2 and 2a. Viking RL pumps operate equally well in either clockwise and counterclockwise rotation. Rotation is determined by viewing the pump from the shaft end. There are two tapped holes in each port to vent the seal chambers. 1/8" pipe plugs are installed on the discharge side of the pump and the holes on the suction side are left open. Standard factory build is clockwise rotation. Pipe plugs must be switched to the opposite port if rotation is reversed.

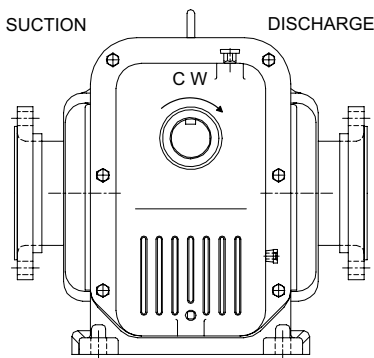

FIGURE 2



FIGURE 2A

PRESSURE RELIEF VALVES

An integral pressure relief valve is not available on this pump. Viking Industrial Rotary Lobe pumps are positive displacement pumps and must be provided with some sort of pressure protection. An inline pressure relief valve, a torque limiting device or a rupture disk must be provided in the pumping system.

MAINTENANCE

Series RL pumps are designed for long, trouble-free service life under a variety of application conditions with a minimum of maintenance. The following points will help provide long service life.

LUBRICATION

CAUTION:

Pumps are supplied without gear case oil. Be sure to add the proper amount and type of lubricant before operating the pump. Do not overfill!

GEAR CASE - Use a grade of gear lube oil with EP (Extreme Pressure) additive for the ambient temperature range.

EP150	0 - 32° F
EP220	32 - 85° F
EP320	above 85° F

Remove oil breather (Item #4) and add 3 Qt. of the specified lubricant. Fill to center of sight glass (Item #6).

After 100 hours of operation, drain and refill with new lubricant and clean off the magnet in the drain plug (Item #1).

Check lubricant level regularly and add lubricant as necessary. Drain and refill with new lubricant every 12 months or 3000 hours of operation, whichever comes first

TAPERED ROLLER BEARINGS

Pumps supplied from the factory are packed with heavy-duty grease. Upon disassembling the bearing housing, the bearings should be cleaned and repacked with heavy-duty multi-purpose grease.

BUSHINGS

The bushings used in this pump are lubricated with the product and do not require any external source of lubrication during operation.

CLEANING THE PUMP

Keep the pump as clean as possible to facilitate inspection and repair work.

STORAGE

If a new pump is to be stored or not used for six months or more, add 5 oz. of non-detergent SAE 30 weight oil in the timing gear box. Viking suggests rotating the pump shaft by hand one complete revolution every 30 days to circulate the oil.

SUGGESTED REPAIR TOOLS

The following tools must be available to properly repair Viking RL pumps. These tools are in addition to standard mechanics' tools such as open end wrenches, pliers, screw drivers, etc. Most items can be obtained from an industrial supply house.

1. Soft headed hammer
2. Allen wrenches
3. Depth micrometer (0-1" Range)
4. Bearing Locknut Spanner Wrench (Source: #472 J.H. Williams & Co. or equal)
5. Brass bar or wood block
6. Arbor Press
7. 3/4" NC X 6" capscrews (2)
8. Bearing Puller

PUMP DISASSEMBLY

DANGER !

Before opening any Viking pump liquid chamber (pumping chamber, reservoir, etc.) be sure:

1. That any pressure in the chamber has been completely vented through the suction or discharge lines or other appropriate openings or connections.
2. That the driving means (motor, turbine, engine, etc.) has been "locked out" or made non-operational so that it cannot be started while work is being done on pump.
3. That you know what liquid the pump has been handling and the precautions necessary to safely handle the liquid. Obtain a material safety data sheet (MSDS) for the liquid to be sure these precautions are understood.
4. That the timing gearbox to cool before handling the pump. The oil will become very hot during normal operation. Allow the timing gearbox oil.

Failure to follow above listed precautionary measures may result in serious injury or death.

1. Turn the centering tabs on the seals 90° (See Figure 8).
2. Remove the (18) nuts holding the head with a 15/16" wrench. Carefully slide head off of studs. If head does not slide freely, insert a dowel pin approx. 1" long into the 3/4" tapped holes (one at the top and bottom) then thread in the 3/4" X 6" capscrews (suggested repair tools #2).

CAUTION: The head weighs 125 pounds and will require two people to handle. See Figure 3.

3. Drain oil in the gear case by removing the pipe plug (item #1). Remove (6) 1/2" capscrews then carefully slide gear case off driver shaft. There is one dowel pin that might restrict removal.



FIGURE 3

4. Straighten out the bearing lockwasher tab on both shafts (See figure 4). Place a wooden block or brass bar in between the lobes to block rotation of the top shaft. Use the spanner wrench (Suggested Repair Tools # 5) to loosen the locknut. Remove the wooden block and insert on the opposite side to restrict movement of the other shaft. Remove the second locknut. Remove both of the lockwashers.

Bearing Lockwasher Tabs



3/8" Jackscrew Holes

FIGURE 4

5. Slide the timing gears off the shafts. If the timing gears do not come off easily, use (3) 1/2" capscrews as jackscrews or a bearing puller (See Figure 4).
6. Remove the keys under the gears. (These are special size keys – do not lose them - standard 5/8" key stock should not be used)
7. Remove the (4) 1/8" allen head pipe plugs (items #29) on the sides of the bracket. Loosen the (4) 5/16" set screws (items #28) that lock the bearing housings in place by 3 full turns.
8. Use the assembly tool shown in Figure 5 to rotate and remove the bearing housing. The bearing housing should come out as an assembly. If it does not, remove the (6) allen head capscrews (Item #13) then the end cap (Item #17). Slide the outer spacer off the shaft.

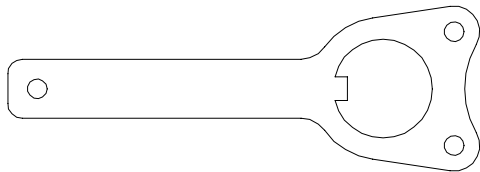

FIGURE 5

Bearing Housing Spanner Wrench
Part No. 2-810-060-375

9. Remove the outer cone of the tapered roller bearing. It might be necessary to thread the bearing housing back into the bracket. Remove the spacer between the two cones and the cup of the bearing set.

CAUTION: It is important to keep the bearing together as a set and in the proper order since the spacer is ground specifically for those components to provide the proper preload.

10. Remove the inner bearing cone, if it doesn't slide freely, reinstall the end cap and capscrews and use a puller (see figures 6 and 10). The back side of the end cap has a machined recess to allow puller usage. Slide the inner spacer (Item #22) off shaft. Repeat the process for the other bearing housing.



FIGURE 6

11. Reposition the pump so the bracket is free standing. See figure 7. Place a lifting strap through the top bearing bore and support from overhead. Remove the (8) 1/2" nuts (Item #26) then remove the bracket. Pull the bracket off of the dowel pin and studs.



FIGURE 7

12. Depending on the type of mechanical seal used, make sure the securing devices to hold or stabilize the seal while removing from the shaft are in place and positioned properly. Unlock the setscrews securing the sleeve to the shaft. Remove the (4) capscrews that hold each seal in place then pull the seal off the shaft.

13. The lobe and shaft assembly is now ready to pull out of the casing.

Caution: This assembly weighs 130 pounds and requires two people or an overhead hoist to handle.

14. Slide the driver shaft out 10" and have one person support the assembly. Continue sliding the assembly out with the other person supporting the opposite end of the shaft. Repeat these steps for the driven shaft.

15. Inspect the labyrinth seals (Item #21) and lip seals in each bearing housing. Leave in the housing unless they show signs of wear or damage (See LABYRINTH SEAL, page 7).

16. Clean all parts thoroughly and examine for wear or damage. Check the lip seals, bearings, bushings and replace if necessary. Check all other parts for nicks, burrs or excessive wear and replace if necessary. Pay special attention to the shaft area underneath the mechanical seal where seal set screws contact.

CAUTION: Do not mix the two bearing cones with respect to the one piece cup.

17. Wash bearings in clean solvent and blow out with compressed air. Make sure bearings are clean, then lubricate with light oil. Check for roughness by placing the cone on the cup and turning.

CARTRIDGE SEALS

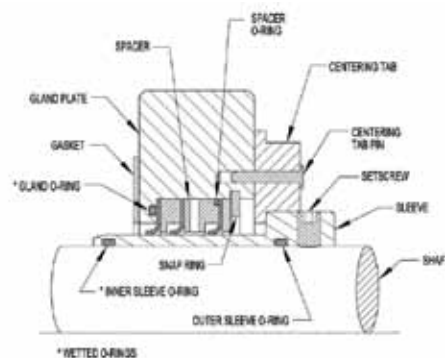

FIGURE 8

The standard seals used in this pump are Fluidtec P/S®-II (Figure 8) and are simple to install. Proper care on installation will help in providing good service life.

Good radial alignment is required for proper operation of the seals. This is accomplished by use of centering tabs provided with each seal. Turn the tabs inward when installing or removing the seal. Turn them outward for normal operation of the pump.

LABYRINTH SEAL

All labyrinth seals contain 4 common parts:

- Stationary Element
- Stationary O-ring
- Rotating Element
- Rotating O-ring

It is recommended to replace any O-rings that are removed from their initial seat. It is recommended to replace the entire seal if the stationary and rotating elements become separated.

ASSEMBLY

- 1.If the casing or head bushings are worn or grooved, install new bushings. Refer to INSTALLATION OF PEEK BUSHINGS, page 9. Head bushings are not generally field replaceable. If these bushings are worn or grooved, consult the factory or you local distributor.

Caution: The lobe and shaft assembly weighs 130 pounds and will require 2 people to install, or the use of an overhead hoist.

- 2.Coat the bottom casing bushing bore with light oil then gently slide the driven shaft (shorter shaft) in place. Hold the shaft as horizontal as possible when installing. This helps avoid damaging the bushing when the step on the shaft slides into the bushing bore. Slide the lobe all the way into the casing bore and position the lobe as shown in Figure 9. Repeat this process with the driver shaft, being careful not to damage the bushing on the shaft's multiple steps. Slide lobe completely into casing.



FIGURE 9

- 3.Position the casing so the bracket can be installed without bearing any load. Refer to figure 8. A lifting strap connected to overhead support will assist in attaching the bracket to the casing. Secure the bracket with the (8) nuts.
- 4.Remove the pump head. Refer now to Figure 10. The bearing housing should already have the inner lip seal and labyrinth seal installed. Press the inner spacer (Item # 22) into the labyrinth seal and lip seal. Install O-rings (Item #19) onto the bearing housings. Thread the bearing housing into the bracket and temporarily install all six 5/16" capscrews to assist in getting the housing threads started. Repeat for the upper bearing housing.

- 5.Apply a liberal coating of anti-seize and lubricating compound (such as NEVER-SEEZ BY BOSTIK) to the shafts and threads. Install the inner bearing cone, cup, spacer (3/8" width), and outer bearing cone. Repeat for the other shaft. Install the bearing endcap. The endcap should have the outer spacer and lipseal already installed. Torque capscrews (Item # 13) evenly to 18 ft-lb torque.

- 6.Add a light film of oil onto the end of the shaft prior to installing the head. This is a temporary installation so you will not need the O-ring in place. Thread in some 3/4" bolts into the back side of the head to help position the head. Line up the head bushing bores with the ends of the two shafts and slide onto the shafts, studs and finally the dowel pins. The head may require lifting slightly to get onto the dowel pins. Place four nuts, one in each corner, onto the head studs to keep the head in place and thread on finger tight.

Caution: Make sure the head is positioned properly over the locating pins before tightening bolts to avoid damaging the bushings. It may be necessary to tap the head with a soft hammer.

- 7.Install the two P/S®-II seals next, starting with the bottom shaft. Coat the shafts and ID of the seals with light oil to facilitate installation. Make sure there are no nicks on the shaft from previous usage. Secure each seal with (4) 5/8" capscrews, lock washers and flat washers (items #30, 43 & 44) and tighten to 15 ft-lb torque.

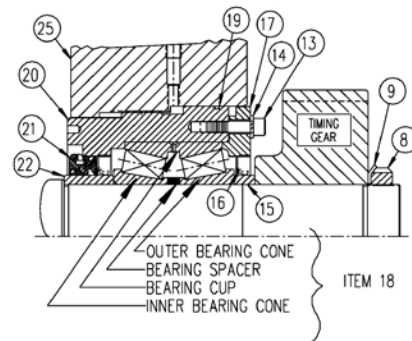

FIGURE 10

- 8.Apply a liberal coating of anti-seize or lubricating compound on the area of the shaft underneath the timing gear. Insert keys into shafts. Install the timing gears, positioned as shown in Figure 11, with arrows meshed. Rotate the driver shaft by hand, to be sure the timing gears are properly aligned. If not, check the arrows again to make sure they are positioned as shown in Figure 11.

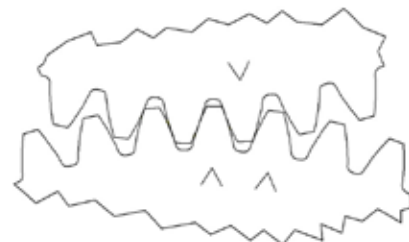

FIGURE 11

9. Rotate each bearing housing assembly clockwise until the lobes project slightly beyond the face of the casing. Place a wooden block or brass bar in between the lobes to block rotation. Install lockwashers and locknuts and tighten with the spanner wrench. Locknuts must be tightened to 600 ft-lb torque. This torque is required to obtain the proper bearing preload and ensure the bearing/timing gear assembly is locked securely on the shaft. This torque can be simulated by applying approximately 600 pounds of weight with a one foot wrench or 200 pounds of weight with a three foot wrench. Adjust the bearing housing assembly to position lobes flush.

Caution: As the locknut is tightened, check to make sure the lobes are still projecting beyond the face of the casing. If they are not, rotate the bearing housing clockwise until they are. **Recheck to make sure the locknuts and end cap capscrews are tight. If left loose, pump end clearance will be lost and the pump may seize.**

10. Set the end clearance. Refer to Thrust Bearing Adjustment, page 8. Put the O-ring in place, then install the gear case by visually centering the lipseal over the shaft. Install the six capscrews, and torque evenly. Fill with gear oil to the middle of the sight glass.

11. Place the O-ring and reinstall the head.

12. Tighten the 6 setscrews around each P/S®-II seal. Turn the centering tabs 90°.

THRUST BEARING ADJUSTMENT

DANGER !

Before opening any Viking pump liquid chamber (pumping chamber, reservoir, etc.) be sure:

1. That any pressure in the chamber has been completely vented through the suction or discharge lines or other appropriate openings or connections.
2. That the driving means (motor, turbine, engine, etc.) has been "locked out" or made non-operational so that it cannot be started while work is being done on pump.
3. That you know what liquid the pump has been handling and the precautions necessary to safely handle the liquid. Obtain a material safety data sheet (MSDS) for the liquid to be sure these precautions are understood.
4. That the timing gearbox to cool before handling the pump. The oil will become very hot during normal operation. Allow the timing gearbox oil.

Failure to follow above listed precautionary measures may result in serious injury or death.

1. Remove the pump head if is not already off.
2. Remove (4) allen head pipe plugs in the side of the bracket. Loosen the setscrews on the bearing housing.
3. Using the bearing housing spanner wrench, turn the bearing housing counter clockwise (viewed from shaft end), until the lobe is touching the bottom of the casing bore.
4. Using a depth micrometer, measure the depth from the front face of the casing to the face of the lobe; this is the total end clearance.
5. Multiply total end clearance by .6. Turn the bearing housing clockwise until the lobe is this distance from the front face of the casing.

Caution: The end clearance must be set while turning the bearing housing assembly clockwise. If set while turning counter-clockwise, the lobes may float and cause damage or galling.

6. Tighten the bearing housing setscrews on both sides of the bracket to 100 in-lbs and install the 1/8" Allen head pipe plugs.
7. Repeat this procedure for the other lobe.

Caution: Recheck to make sure the locknuts and end cap capscrews are tight. If left loose, the end clearance may be lost, resulting in pump seizure.

DANGER!

Before starting pump, be sure all drive equipment guards are in place.

Failure to properly mount guards may result in serious injury or death.

DANGER!

Failure to Follow the above listed precautionary measures may result in serious injury or death.

INSTALLATION OF PEEK® BUSHINGS

When installing the bushings, extreme care must be taken to prevent breaking. The additional precautions listed below must be followed for proper installation:

- A press must be used for installation.
- Use Loctite® #4203 or #411 on the outside of the bushing to hold the bushing in the housing.
- Be certain that the bushing is straight. The groove in the bushing should line up with the groove in the casing.
- Do not stop the pressing operation until the bushing is in the proper position; starting and stopping may result in a cracked bushing.
- Check the bushing for damage after installation.

PEEK® is a trademark of Victrex PLC

Loctite® is a trademark of Henkel Consumer Adhesives, Inc.



TECHNICAL SERVICE MANUAL

INDUSTRIAL ROTARY LOBE PUMP
MODEL RL41507

SECTION	TSM 270
PAGE	10 OF 10
ISSUE	F



WARRANTY

Viking warrants all products manufactured by it to be free from defects in workmanship or material for a period of one (1) year from date of startup, provided that in no event shall this warranty extend more than eighteen (18) months from the date of shipment from Viking. The warranty period for Universal Seal series pumps ONLY (Universal Seal models listed below) is three (3) years from date of startup, provided that in no event shall this warranty extend more than forty-two (42) months from the date of shipment from Viking.

UNDER NO CIRCUMSTANCES SHALL VIKING BE LIABLE UNDER THIS WARRANTY OR OTHERWISE FOR SPECIAL, INCIDENTAL, INDIRECT, CONSEQUENTIAL OR PUNITIVE DAMAGES OF ANY KIND, INCLUDING, BUT NOT LIMITED TO, LOST OR UNREALIZED SALES, REVENUES, PROFITS, INCOME, COST SAVINGS OR BUSINESS, LOST OR UNREALIZED CONTRACTS, LOSS OF GOODWILL, DAMAGE TO REPUTATION, LOSS OF PROPERTY, LOSS OF INFORMATION OR DATA, LOSS OF PRODUCTION, DOWNTIME, OR INCREASED COSTS, IN CONNECTION WITH ANY PRODUCT, EVEN IF VIKING HAS BEEN ADVISED OR PLACED ON NOTICE OF THE POSSIBILITY OF SUCH DAMAGES AND NOTWITHSTANDING THE FAILURE OF ANY ESSENTIAL PURPOSE OF ANY PRODUCT.

THIS WARRANTY IS AND SHALL BE VIKING'S SOLE AND EXCLUSIVE WARRANTY AND SHALL BE IN LIEU OF ALL OTHER WARRANTIES, EXPRESS OR IMPLIED, INCLUDING, BUT NOT LIMITED TO, ALL WARRANTIES OF MERCHANTABILITY, FITNESS FOR A PARTICULAR PURPOSE AND NON-INFRINGEMENT ALL OF WHICH OTHER WARRANTIES ARE EXPRESSLY EXCLUDED.

See complete warranty at www.vikingpump.com.

