

ARGUS MODEL 'F' & 'P' PIG VALVES

Installation, Operation, and Maintenance Manual

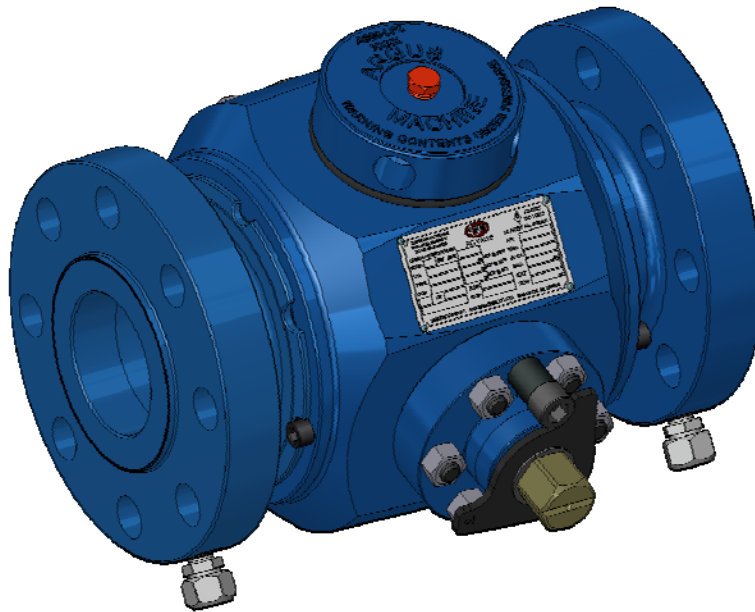

Dedicated to Improving Your Operations for Over 50 Years

Argus Machine Co. Ltd. • 5820 - 97 Street, Edmonton, Alberta, Canada T6E 3J1
Phone: (780) 434-9451 • Fax: (780) 434-9909 • www.argusmachine.com

TABLE OF CONTENTS

1.0	SCOPE	2
2.0	GENERAL	2
3.0	APPLICABLE STANDARDS	2
4.0	SAFETY	2
5.0	HANDLING AND STORAGE	3
5.1	HANDLING	3
5.2	STORAGE	3
6.0	INSTALLATION	3
6.1	INLET AND OUTLET PIPING	3
6.2	ORIENTATION	3
6.3	MOUNTING	4
7.0	OPERATION	5
7.1	PIG SENDING	6
7.2	PIG RECEIVING	9
7.3	IMPACT DAVIT OPERATION	10
7.4	PRESSURE ALERT VALVE OPERATION	11
8.0	MAINTENANCE	12
9.0	INJECTION GUIDELINES	14
9.1	INTRODUCTION	14
9.2	GENERAL	14
9.3	INJECTION EQUIPMENT	14
9.4	CLEANERS	14
9.5	LUBRICANTS	14
9.6	SEALANTS	14
10.0	TROUBLESHOOTING	15
11.0	HOW TO ORDER PIG VALVES & PIG VALVE SERVICE	16
11.1	ORDERING ARGUS PIG VALVES	16
11.2	ORDERING SERVICE FOR ARGUS PIG VALVES	16
11.3	CONTACT INFORMATION	16



1.0 SCOPE

Argus Machine Co. Ltd. (Argus) manufactures Pig Ball Valves (Pig Valves) with threaded and/or flanged connections. This manual covers the installation, operation, and maintenance of Argus Pig Valves.

2.0 GENERAL

Installation, operation, and maintenance of Pig Valves models “F” & “P” shall comply with the procedures as described in this manual.

The Pig Valve is a double block and bleed valve which allows pigs to be inserted and removed, providing a safe and convenient alternative to the traditional method of pigging operations (with valves, tees, and traps). This is made possible by having independent upstream and downstream seats which isolate the body cavity from the upstream and downstream pressures when the valve is “**CLOSED**”. An entry plug located at the top of the Pig Valve main body allows pigs to be inserted into and removed from the flow line when the valve is in the closed position.

- 1) Operating temperature range is -50°F (-46°C) to +250°F (+121°C).
- 2) Manufactured for sweet and sour service.
- 3) Capable of sending and receiving “Bullet”, “Scraper”, and “Spherical” type pigs.

3.0 APPLICABLE STANDARDS

The Pig Valve has been designed to meet the requirements of the following applicable standards:

- 1) API 6D/ISO 14313
- 2) API 598
- 3) NACE MR0175
- 4) ASME B16.5, B16.34, B31.3, & Section VIII
- 5) MSS SP-25

Face to face dimensions meet API 6D specifications unless otherwise indicated (see “TB-PV-008” technical bulletin).

4.0 SAFETY

Many routine procedures are potentially hazardous if executed incorrectly or in unsafe conditions, particularly when toxic/flammable product is present. Caution must also be exercised when high temperature and/or pressure exist in the system. The routine of sending a pig and receiving a pig, while not complex, requires prudence to prevent personal injury and/or damage to the equipment. The procedures detailed in this manual must be followed closely.

Other precautions that **MUST** be observed are listed below:

- 1) Pig Valves **MUST** be suitable for the service conditions.
- 2) Always follow government and site safety regulations.
- 3) Use appropriate safety equipment and clothing, including eye protection, when operating the Pig Valve.
- 4) Stand clear when bleeding down the main body cavity and removing the entry plug, to prevent exposure to spray, splatter, or spillage of any hazardous media which may be contained inside the valve.
- 5) Always use Argus O.E.M. parts for service and repair.
- 6) Never strike the Pig Valve or attached equipment (except for hammer lug style entry plugs).
- 7) All accessories attached to the Pig Valve **MUST** be suitable for the service conditions.
- 8) Never install or remove accessories from a Pig Valve that is under pressure.



5.0 HANDLING AND STORAGE

5.1 HANDLING

- 1) Do not lift the Pig Valve by any part of the gear operator, impact davit or any other accessories attached to the Pig Valve.
- 2) Pig Valves, either crated or uncrated, should never be subjected to sharp impact. Specifically, the Pig Valve must not be bumped or dropped during installation.

5.2 STORAGE

- 1) Pig Valves should be stored in a clean dry environment and should be left on shipping pallets or in original packaging prior to installation.
- 2) All flange protectors should remain in place until installation of Pig Valve.
- 3) Pig Valves should be stored in the “**FULLY OPEN**” position (prevents damage to ball).

6.0 INSTALLATION

6.1 INLET AND OUTLET PIPING

- 1) Ensure the Pig Valve connections match (see nameplate on Pig Valve) the nominal size and pressure rating of the inlet and outlet piping connections (e.g. 4” 150 ANSI Class RF flanged connection).
- 2) It is the responsibility of the piping designer to address vibration, thermal effects, line stresses, supports or any other factors that may occur due to field conditions.
- 3) The inlet and outlet piping connections shall be aligned in such a manner to minimize additional stresses due to Pig Valve installation.
- 4) Determine if a by-pass line is necessary to prevent pressure build-up of flow line during the pigging operation.

6.2 ORIENTATION

(Refer to Figure 1)

- 1) Pig Valves can be installed with the entry plug facing either upward or to the side with the flow being horizontal. It is **RECOMMENDED** to install the Pig Valve with the entry plug facing upward to avoid spillage of media during the insertion and removal of pigs. Also, the entry plug is easier to handle when installed in the vertical position.
- 2) Pig Valve models equipped with the Argus “Multi-Pig Launcher” (see “TB-ML-002” technical bulletin) or “impact davit” (see “Impact Davit Operation”), **MUST** be installed with the “Multi-Pig Launcher” or “impact davit” facing upward.
- 3) Flow direction is indicated on the Pig Valve nameplate beside “FLOW”. When marked L←R flow is from the right side to the left side of Pig Valve. When marked L→R flow is from the left side to the right side of Pig valve.

NOTE:

Pig Valve “sender type” (Sender) if equipped with an optional tailpiece stopper **MUST** be installed with the tailpiece stopper in the upstream tailpiece. Pig Valve “receiver type” (Receiver) **MUST** have the tailpiece stopper installed in the downstream tailpiece. Consult factory for non-standard pig stoppers.



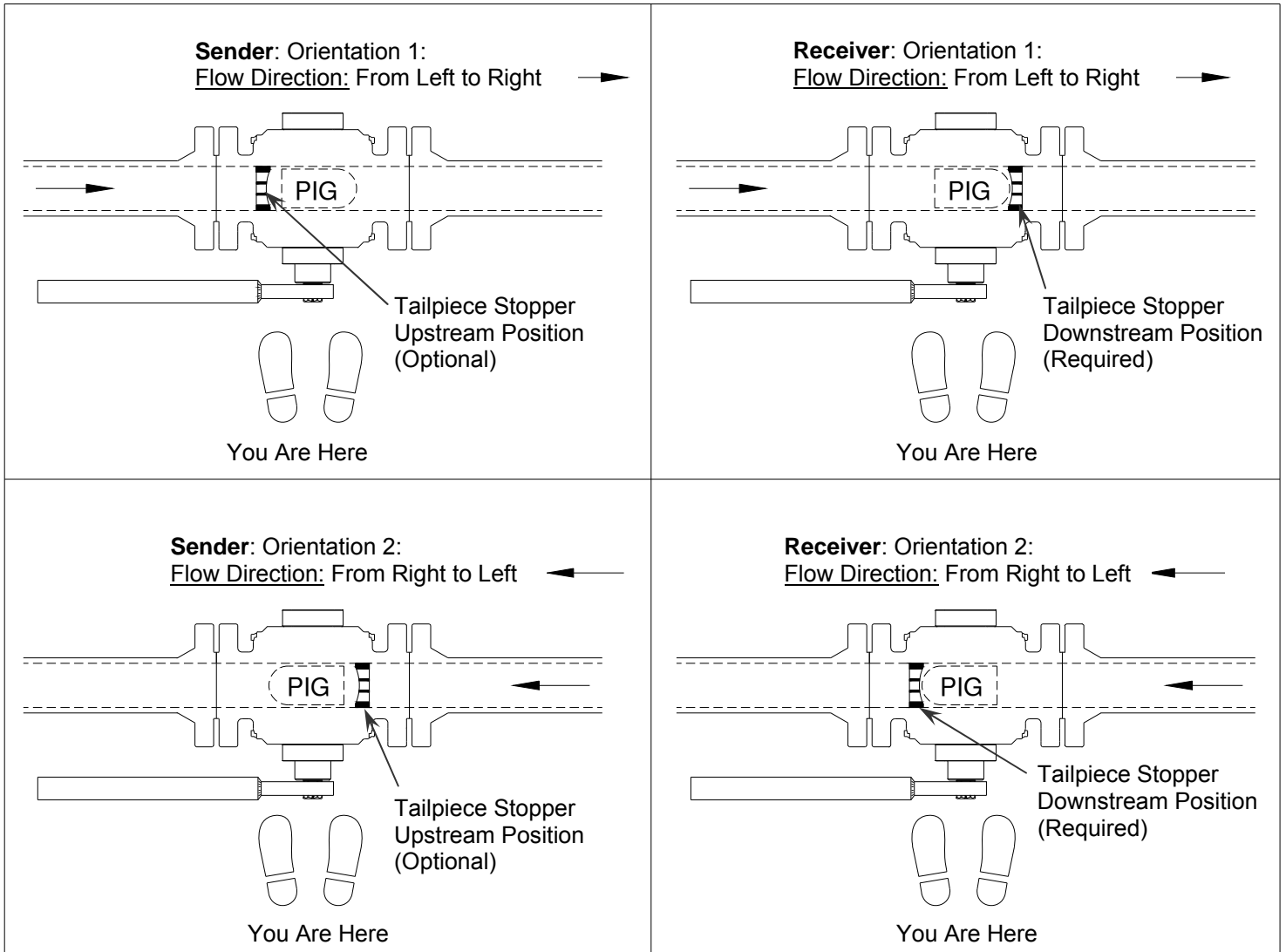
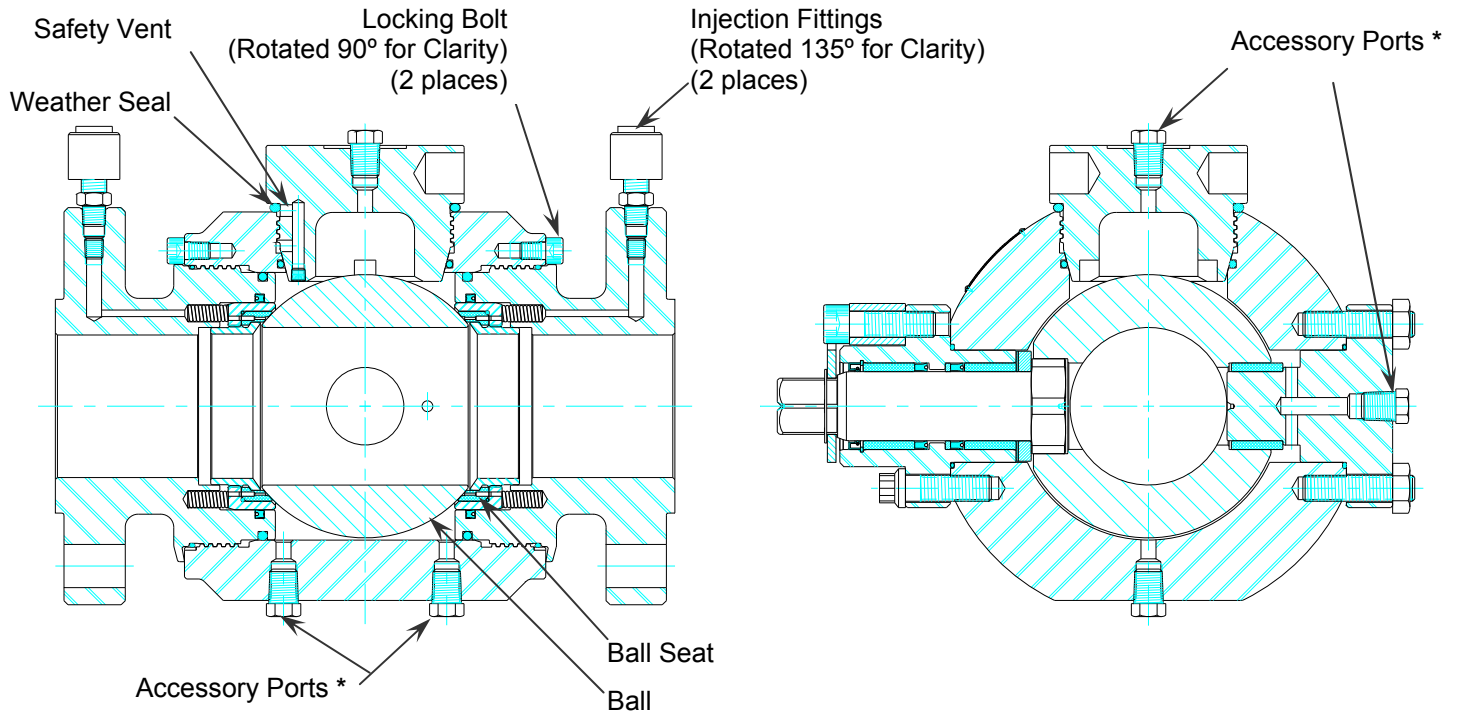

Figure 1: Pig Valve Orientation

6.3 MOUNTING

- 1) Prior to installation and once the flange protectors have been removed the Pig Valve should be inspected both inside for foreign materials and outside for signs of tampering or damage.
- 2) All sealing surfaces **MUST** be free of foreign material and damage.
- 3) Allow sufficient workspace around the Pig Valve for accessibility to allow for proper servicing and/or removal.
- 4) Pig Valve **MUST** be installed in the “**FULLY OPEN**” position.
- 5) Ensure that at least one of the accessory ports in the Pig Valve has been equipped with a bleed valve (see Figure 2).
- 6) All flange studs and nuts must be tightened as recommended by industry standards.





* Locations for bleed valve, gauge or other accessories.

Figure 2: Argus Pig Valve Model "P"

7.0 OPERATION

(Refer to Figures 3, 4 & 5)

In the following section on Argus Pig Valve Operation, it is assumed that the orientation of the Pig Valve is such that the rotating stem / gear operator is facing the field technician and the flow is "left to right" for pig sending and receiving.

CAUTION:

- 1) Do **NOT** leave Pig Valve in a partially open position as this may damage the seats.
- 2) Before closing Pig Valve, the pipeline must be cleaned to purge all foreign materials, which may cause damage to the ball and/or ball seats (typical for new or repaired pipelines).
- 3) Pigs must not exceed Argus maximum recommended dimensions (see "TB-PV-001" technical bulletin).
- 4) Steel brush style pigs are **NOT** recommended. The wires may scratch the seat and/or ball sealing surfaces or come loose and wedge between the seat and ball.
- 5) Use Argus Pig Valve wrench to operate Pig Valve. Other types of wrenches may damage rotating stem.



7.1 PIG SENDING

- 1) Open by-pass valve (if present).
- 2) Close Pig Valve (clockwise when flow is L→R and counterclockwise when flow is L←R). The flow indicator on the rotating stem **MUST** be at a right angle to the flow line. If the Pig Valve is equipped with a gear operator, the “indicator” on the hub **MUST** read “**CLOSED**”.
- 3) Slowly open bleed valve, bleeding pressure and draining fluid from Pig Valve main body cavity.
- 4) Slowly loosen entry plug (refer to Figure 3 to determine style of entry plug) by rotating counterclockwise using a “non-spark mallet”, “wrench” or “impact davit”. Observe the safety vent area (covered by the weather seal) at the top of the threads on entry plug (see Figure 2). If there is any media flowing from this area when the entry plug is being loosened, immediately re-tighten entry plug. Repeat steps 3 and 4. If unable to bleed all pressure from body cavity refer to the “Troubleshooting” section in this manual.

WARNING: Do **NOT** loosen entry plug more than one-half turn until certain there is **NO** leakage from the vent area. Failure to follow these instructions may result in serious injury or fatality.

- 5) Remove entry plug.

CAUTION: It is important to prevent any foreign material from entering Pig Valve main body cavity when entry plug is removed. Ensure entry plug stays clean and free of damage when removed from Pig Valve.

- 6) Insert pig into Pig Valve. Bullet type pigs **MUST** be inserted nose down.
- 7) Before installing the entry plug, check that the bevel sealing area and threads on both the entry plug and main body are free of foreign material and burrs. Make sure the o-ring in the main body entry plug opening is not damaged (replace as required).
- 8) Install entry plug.

CAUTION: Do **NOT** over-tighten the entry plug. Excessive tightening (hammering after entry plug has stopped rotating) can cause damage to the entry plug and/or the main body.

- 9) Close all bleed valves.
- 10) Equalize cavity pressure with the pressure equalizing valve (if present).
- 11) Open Pig Valve to send pig into the flow line.
- 12) Close by-pass valve (if present).

NOTE: When equipped with a by-pass line, the by-pass shut-off valve may need to be closed prior to opening the Pig Valve and sending the pig. This will help build up sufficient pressure upstream of the pig to push it into the downstream piping. The extent of line contamination and the interference fit between the pig and flow line will determine whether this is necessary.



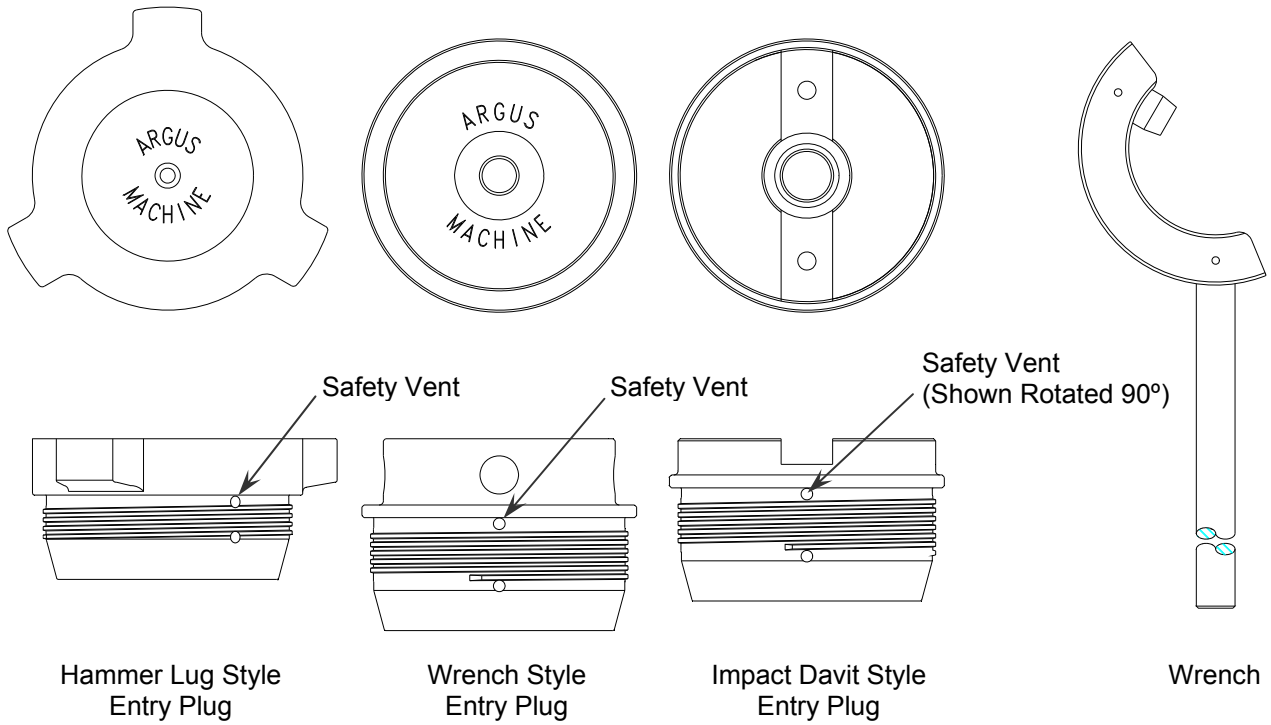

Figure 3: Argus Entry Plug Styles



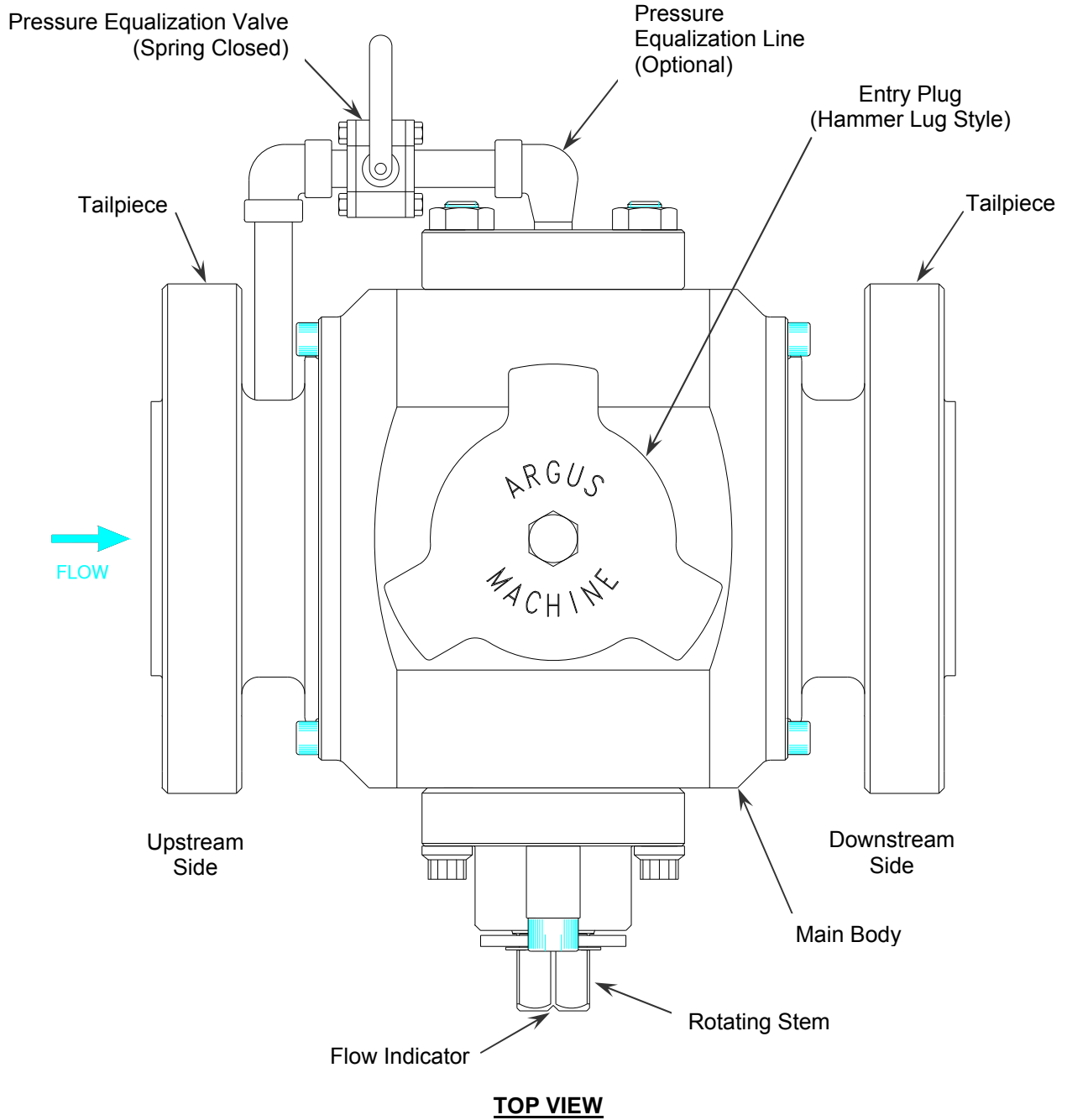

Figure 4: Argus Pig Valve



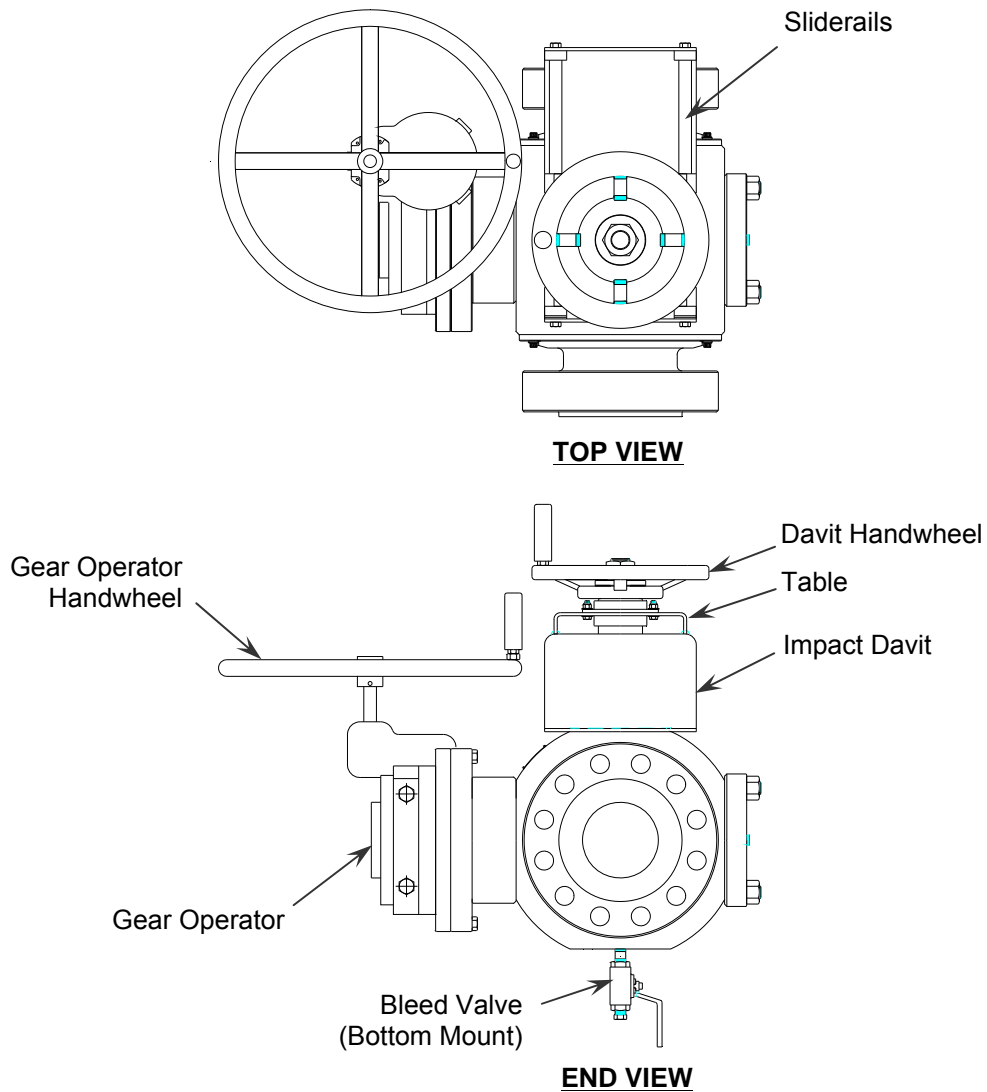

Figure 5: Argus Pig Valve c/w Impact Davit & Gear Operator

7.2 PIG RECEIVING

- 1) Once the pig has reached the Pig Valve, open by-pass valve (if present).
- 2) Close Pig Valve (clockwise when flow is L→R and counterclockwise when flow is L←R). The flow indicator on the rotating stem **MUST** be at a right angle to the flow line. If the Pig Valve is equipped with a gear operator, the “indicator” on the hub **MUST** read “**CLOSED**”.
- 3) Slowly open bleed valve bleeding pressure and draining fluid from Pig Valve main body cavity.
- 4) Slowly loosen entry plug (refer to Figure 3 to determine style of entry plug) by rotating counterclockwise using a “non-spark mallet”, “wrench” or “impact davit”. Observe the safety vent area (covered by the weather seal) at the top of the threads on entry plug (see Figure 2). If there is any media flowing from this area when the entry plug is being loosened, immediately re-tighten entry plug. Repeat steps 3 and 4. If unable to bleed all pressure from body cavity refer to the “Troubleshooting” section in this manual.

WARNING: Do NOT loosen entry plug more than one-half turn until certain there is NO leakage from the vent area. Failure to follow these instructions may result in serious injury or fatality.



- 5) Remove entry plug.

CAUTION: It is important to prevent any foreign material from entering Pig Valve main body cavity when entry plug is removed. Ensure the entry plug stays clean and free of damage when removed from Pig Valve.

- 6) Remove pig from Pig Valve.

WARNING: Should the pig be difficult to remove, do NOT use excessive side force. This may result in damage to the pig, entry plug seal area, or ball. More importantly, it may shift the ball causing leakage across the ball seat releasing hazardous media. Pull the pig directly out of the Pig Valve without working it from side to side. Failure to follow these instructions may result in serious injury or fatality.

- 7) Before installing entry plug, check that the bevel sealing area and threads on both entry plug and main body are free of foreign material and burrs. Make sure the o-ring in main body entry plug opening is not damaged (replace as required).

- 8) Install entry plug.

CAUTION: Do NOT over-tighten the entry plug. Excessive tightening (hammering after entry plug has stopped rotating) can cause damage to the entry plug and/or the main body.

- 9) Close all bleed valves.

- 10) Equalize cavity pressure with the pressure equalization valve (if present).

- 11) Open Pig Valve.

- 12) Close by-pass valve (if present).

7.3 IMPACT DAVIT OPERATION (Refer to Figure 5)

This section applies to only those Argus Pig Valves equipped with an impact davit (standard on larger size Pig Valves) for easy removal and installation of the entry plug.

CAUTION: Disassembly and swapping of impact davits may cause malfunction and/or damage to the equipment. If disassembly or repair is required consult the factory for procedures.

- 1) With Pig Valve closed and the pressure bled off, rotate impact davit handwheel clockwise until all “freeplay” in stem is gone (approximately one-quarter turn).
- 2) Quickly and firmly, swing impact davit handwheel counterclockwise creating a hammering effect on entry plug. This will loosen the entry plug a small amount. Repeat until entry plug is loose (approximately 3 to 5 times).

WARNING: Do NOT loosen entry plug more than one-half turn until certain there is NO leakage from the vent area. Failure to follow these instructions may result in serious injury or fatality.

- 3) Once entry plug is loose, the impact davit handwheel can be turned counterclockwise continuously until entry plug lifts out of main body and reaches the top of its travel.
- 4) Slide table (with entry plug attached) to the opposite end of sliderails to expose Pig Valve main body cavity.

CAUTION: Make sure that no part of entry plug strikes the Pig Valve or impact davit assembly.

- 5) Insert pig into the ball if “pig sending”. Remove pig from the ball if “pig receiving”.

- 6) Ensure that the bevel sealing area and threads on both the entry plug and main body are free of foreign material and burrs. Make sure the o-ring in main body entry plug opening is not damaged (replace as required).

- 7) Slide the table (with entry plug attached) back over entry plug opening.



- 8) Rotate impact davit handwheel clockwise, lowering entry plug and continue turning impact davit handwheel until entry plug is seated metal to metal in the Pig Valve main body.

CAUTION: Ensure first thread on entry plug engages freely before proceeding. If first thread does not engage freely back entry plug off and inspect threads for damage or contamination (clean or repair threads as required).

- 9) Rotate the impact davit handwheel counterclockwise until all “freeplay” in stem is gone (approximately one-quarter turn).
- 10) Quickly and firmly, swing impact davit handwheel clockwise to drive entry plug closed. Repeat steps 9 & 10 making certain that entry plug is seated (approximately 3 to 5 times).

CAUTION: Do **NOT** over-tighten the entry plug. Excessive tightening (hammering after entry plug has stopped rotating) can cause damage to the entry plug and/or the main body.

7.4 PRESSURE ALERT VALVE OPERATION (Refer to Figure 6)

This section applies to only those Argus Pig Valves equipped with a Pressure Alert Valve (PAV) (optional on Pig Valves with wrench style entry plugs) for an additional feature to alert cavity pressure.

- 1) With Pig Valve closed and the cavity pressure bled down, proceed to unscrew PAV stem.

WARNING: Do **NOT** remove Pressure Alert Valve stem if there is pressure present while unthreading. Failure to follow these instructions may result in serious injury or fatality.

NOTE: The pressure alert valve is not intended to be used to bleed down cavity pressure.

- 2) Once the stem is removed from the PAV body place it and the chain on top of entry plug to ensure it will not catch on anything while unscrewing the entry plug.

WARNING: Do not cut, or break chain off from entry plug because it will render this safety device useless. Failure to follow these instructions may result in serious injury or fatality.

- 3) Slowly loosen entry plug (refer to Figure 3 to determine style of entry plug) by rotating counterclockwise using the supplied entry plug wrench. Observe the safety vent area (covered by the weather seal) at the top of the threads on entry plug (see Figure 2). If there is any media flowing from this area when the entry plug is being loosened, immediately re-tighten entry plug. Slowly open bleed valve to valve bleeding pressure and draining fluid from Pig Valve main body cavity. If unable to bleed all pressure from body cavity refer to the “Troubleshooting” section in this manual.

WARNING: Do **NOT** loosen entry plug more than one-half turn until certain there is **NO** leakage from the vent area. Failure to follow these instructions may result in serious injury or fatality.

WARNING: Be sure that while using entry plug wrench not to disturb the Pressure Alert Valve that protrudes from the valve body. Failure to follow these instructions may result in serious injury or fatality.

- 4) For Pig Sending refer to (7.1 steps 5 to 10) and for Pig Receiving refer to (7.2 steps 5 to 10).
- 5) Reattach stem and chain by threading clockwise into body of the PAV.
- 6) If Pig Sending open Pig Valve to send pig into the flow line.
- 7) If Receiving open Pig Valve.
- 8) Close by-pass valve (if present).



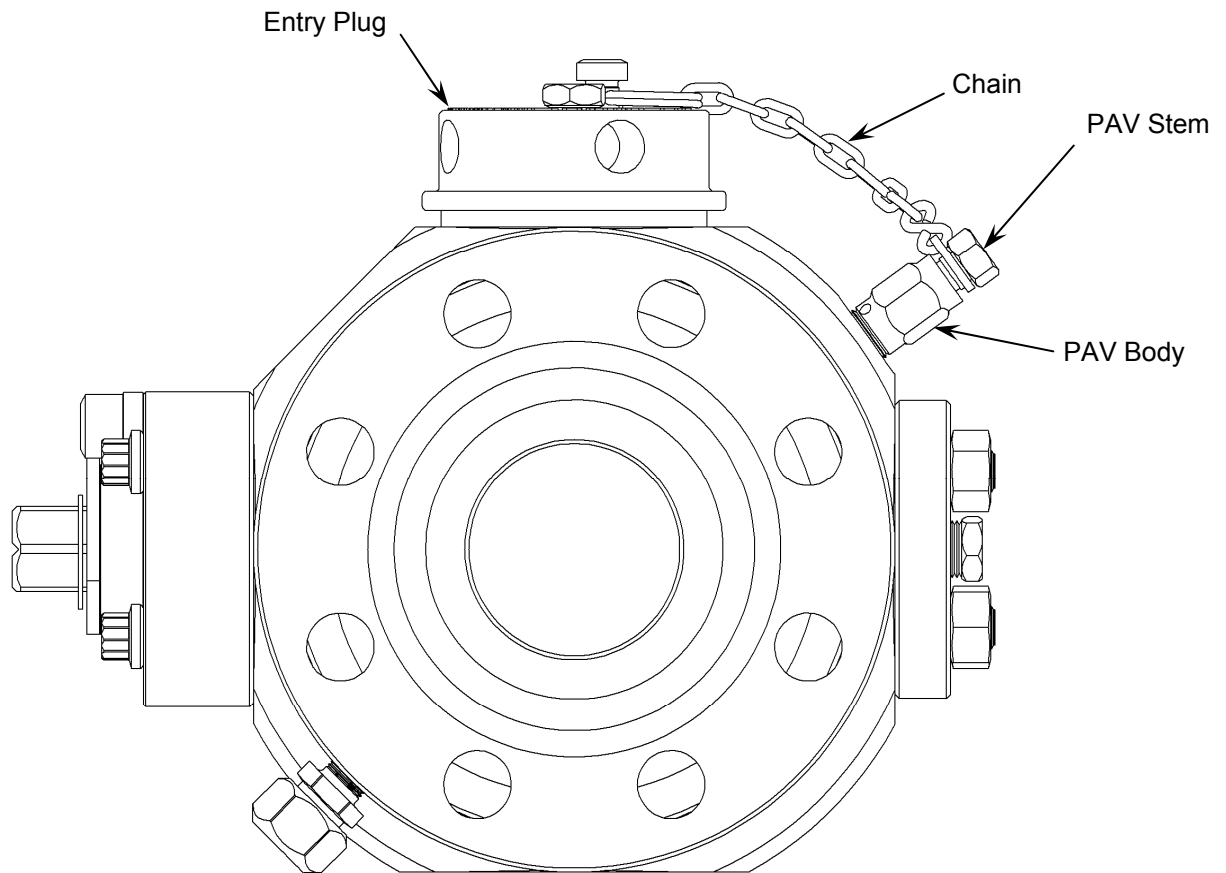

Figure 6: Argus Pig Valve c/w Pressure Alert Valve

8.0 MAINTENANCE

- 1) In climates where the flow line experiences freezing temperatures, drain any water or other media (which may solidify) from the Pig Valve thru the accessory ports on the bottom of the main body.

CAUTION: Media left in Pig Valve that is susceptible to freezing may damage the Pig Valve.

- 2) If Pig Valve is a model "P" it is recommended to grease Pig Valve before each pigging operation (see "Injection Guidelines").
- 3) 4" 1500, 6" 1500 and 8" 150-1500 ANSI Class model "P" Pig Valves are equipped with a modified 3/8" pipe plug that has a built in leak path (see Figure 7). Should the primary rotating stem seal fail a small amount of grease will be displaced thru this modified pipe plug.
 - a) Close Pig Valve and bleed all main body cavity pressure.
 - b) Replace modified pipe plug with a standard 3/8" pipe plug.
 - c) Service Pig Valve as soon as possible.
- 4) It is recommended to inspect entry plug seal and sealing surface during the regular pigging operation (when entry plug is removed). Replace seal and repair seal surface as required (see "Service Manual").
- 5) Every 2 to 3 months Argus recommends cycling the Pig Valve to ensure that it operates smoothly. Cycle more often in severe service to maintain smooth operation.
- 6) In severe service, where media build up may be a concern, it is recommended to inject cleaners as required (see "Injection Guidelines").



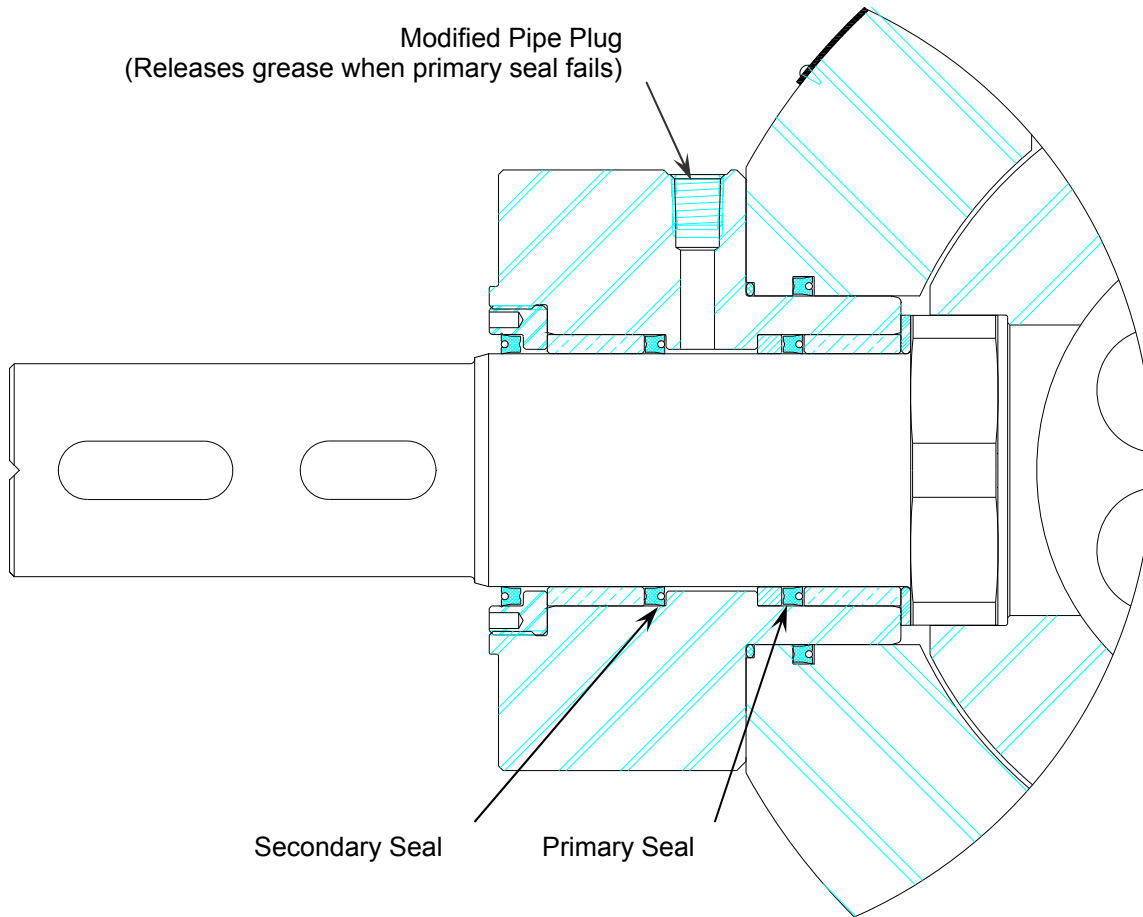

Figure 7: Stuffing Box Sub-Assembly c/w Modified Pipe Plug



9.0 INJECTION GUIDELINES

(Refer to Figure 2)

9.1 INTRODUCTION

- 1) Argus model "P" Pig Valves are equipped with seat injection ports. These ports are used to inject cleaners, lubricants and sealants into the interface between the seat insert and the ball. Periodic injection of these cleaners, lubricants and sealants will reduce downtime, costly repairs and prolong the life of the Pig Valve. Cleaners and lubricants are especially recommended for severe service applications.

9.2 GENERAL

- 1) Refer to manufacturers' instructions for use of injection equipment, cleaners, lubricants, and sealants.
- 2) Best results are achieved by injecting cleaners and/or lubricants while Pig Valve is in the "FULLY OPEN" or "CLOSED" position.
- 3) Inject a sufficient quantity of cleaner, lubricant or sealant as required. A rule of thumb is to inject approximately 1-2 ounces (20 to 40 strokes, when using Sealweld® SuperGun) per inch of valve size into each injection fitting.

9.3 INJECTION EQUIPMENT

WARNING: Read and follow all manufacturers' instructions for safe operation of injection equipment. Failure to follow these instructions may result in serious injury or fatality.

- 1) Injection equipment is required to inject cleaners, lubricants and sealants into the Pig Valve.
- 2) Recommend Sealweld® SuperGun or equivalent.

9.4 CLEANERS

- 1) Cleaners are used to clean critical seal surfaces and sealant passages by softening, flushing and removing old sealants, residual buildup and foreign particles (such as sand, debris, scales, etc).
- 2) Recommend Sealweld® Valve Cleaner Plus or equivalent.

9.5 LUBRICANTS

- 1) Lubricants are designed to protect critical seal surfaces against corrosion and flush out pipeline contaminants, as well as reduce operating torque requirements.
- 2) Recommend Sealweld® Equa-Lube Eighty lubricant, Chemola Desco 622 lubricant/sealant, or equivalent.

9.6 SEALANTS

WARNING: Pigging the flow line is NOT recommended after sealant has been injected into Pig Valve (repair the Pig Valve before continuing pigging operation). Sealant may be used to ensure positive shut-off of the flow line when the Pig Valve is closed. Failure to follow these instructions may result in serious injury or fatality.

- 1) Sealants are designed specifically for use with minor to severe leaking valves and emergency valve sealing operations.
- 2) Recommend (minor leakage): Sealweld® Total-Lube #911 lubricant/sealant or equivalent.
- 3) Recommend (severe leakage): Sealweld® Ball Valve Sealant #5050 sealant or equivalent.



10.0 TROUBLESHOOTING

Problem	Possible Causes	Possible Solutions
Pig Valve won't open.	<ul style="list-style-type: none"> a) High torque. b) Media build up causing a sticking effect on moving parts. c) Media inside Pig Valve is frozen. 	<ul style="list-style-type: none"> a) Open pressure equalization line (if equipped). Check equalization line/valve for blockage and repair as required (see "Service Manual"). b) Inject valve cleaner and lubricant into ball seats (Model "P" only), (see "Injection Guidelines"). c) De-ice.
Pig Valve won't close.	<ul style="list-style-type: none"> a) Foreign matter caught in ball and/or ball seats. b) Stops not set properly on gear operator (if equipped). 	<ul style="list-style-type: none"> a) Remove Pig Valve from flow line and repair (see "Service Manual"). b) Adjust stops on gear operator (see gear operator "Operating Manual").
Pig Valve cavity will not bleed down when in "CLOSED" position.	<ul style="list-style-type: none"> a) Foreign matter caught in ball and/or ball seats. b) Ball core seats scratched. c) Equalization valve leaks (if equipped). d) Stops not set properly on gear operator (if equipped). e) Bleed Valve plugged. f) Pig Sealed on face of Entry Plug. 	<ul style="list-style-type: none"> a) Inject cleaner and lubricant into ball core seats (model "P" only, see "Injection Guidelines"). b) Remove Pig Valve from flow line and repair (see "Service Manual"). c) Remove Pig Valve from flow line and repair (see "Service Manual"). d) Adjust stops on gear operator (see gear operator "Operating Manual"). e) Replace bleed valve. Close Pig Valve and bleed down main body cavity (see "Operation"). f) Use alternate bleed valve, or isolate valve and bleed down the line and remove the Pig.
Leakage around entry plug.	<ul style="list-style-type: none"> a) O-ring seal damaged. b) Seal surface damaged. c) Foreign matter on seal surface. 	<ul style="list-style-type: none"> a) Remove entry plug and replace o-ring seal. b) Remove entry plug and inspect seal surfaces repair as required (see "Service Manual"). c) Remove entry plug and clean off foreign matter.
Leakage around tailpiece.	<ul style="list-style-type: none"> a) Primary seal in tailpiece is damaged. b) Seal surfaces damaged. 	<ul style="list-style-type: none"> a) Remove Pig Valve from flow line and replace primary seal (see "Service Manual"). b) Remove Pig Valve from flow line inspect seal surfaces and repair as required (see "Service Manual").
Bleed valve leaking.	<ul style="list-style-type: none"> a) Seats and/or seals damaged. b) Bleed valve not closed. 	<ul style="list-style-type: none"> a) Replace bleed valve. Close Pig Valve and bleed down main body cavity (see "Operation"). b) Close bleed valve.



11.0 HOW TO ORDER PIG VALVES & PIG VALVE SERVICE

11.1 ORDERING ARGUS PIG VALVES

When Argus Pig Valves are ordered, the following information will be required:

- 1) Model
- 2) Size
- 3) ANSI Class pressure rating and flange type (e.g. 600 ANSI Class RF)
- 4) Pig Sender or Pig Receiver
- 5) Flow direction (from “left to right” or “right to left”, with “rotating stem” facing user)
- 6) Type of pig (Sphere or Bullet/Scraper)
- 7) Quantity of pigs required
- 8) Quantity of Pig Valves required
- 9) Tailpiece pig stopper (optional on “Senders”)
- 10) Gear operator (optional on some sizes)
- 11) Automatic or manual multi-pigging (optional, see “Multi-Pig Launcher” bulletin)
- 12) Pressure equalization line (optional & not available on all sizes)
- 13) Options or accessories

11.2 ORDERING SERVICE FOR ARGUS PIG VALVES

When requesting service for Argus Pig Valves, please provide the following data to the Service Department:

- 1) Size
- 2) Model
- 3) ANSI Class pressure rating
- 4) Serial Number

Example: 6” Pig Valve
 Model “P”
 1500 ANSI Class
 S/N PV 0100

11.3 CONTACT INFORMATION

For Ordering Argus Pig Valves or Argus Pig Valve service:

Argus Machine Co. Ltd.
Order Desk (Assembly Division)
5720-97 Street,
Edmonton, Alberta, Canada
T6E 3J1

Toll Free: 1-888-434-9451
Phone: (780) 434-9451
Fax: (780) 434-9909



PIG VALVE
INSTALLATION, OPERATION,
AND MAINTENANCE

AOM-PV01
November 2010
Page 16