



2001 MARS SERVICE MANUAL

I. ANSWER PRECISION SUSPENSION

THANK YOU FOR CHOOSING THE HIGHEST TECHNOLOGY MOUNTAIN BIKE SUSPENSION FORK AVAILABLE. 2001 MARS FORK MODELS HAVE STATE OF THE ART AIR SPRING SYSTEMS. THE MARS SERIES ALL USE THE TWIN PISTON CHAMBER SYSTEM (TPC) THAT SURPASS ALL OTHER TYPES OF OIL DAMPED SYSTEM IN PERFORMANCE AND DURABILITY.

Your 2001 MARS Fork is fully assembled and ready to for installation onto your bicycle and comes equipped with a 1 1/8 threadless steerer tube. All MARS forks come in two versions: standard and No-Boss. The standard version has mounts for both V-brakes and disc brakes. The No-Boss version has the cantilever brake boss removed and is for disk brake use only.

II. CONSUMER SAFETY INFORMATION

GENERAL WARNING: Bicycling is a hazardous activity that requires that the rider stay in control of his or her bicycle at all times. Reading this manual entirely and properly maintaining your bicycle and suspension fork will reduce the possibility of injury or possible death. Prior to riding your bicycle, you should inspect your suspension fork to ensure that no damage has occurred during the course of riding. Do not ride your bicycle if the fork shows any signs of bending, cracking, leaking, or if it is missing any of the originally supplied components. Any fall from your bicycle can result in serious injury or even death. Following these instruction can help you reduce the risk of being injured.

If you are a moderate or aggressive off-road rider, or ride at least three times a week over rough terrain, Answer recommends returning your suspension fork every 2 years for a through inspection and update. Take your fork to a Manitou authorized dealer who can arrange for shipment to Answer Products, or you may call Answer to have your fork shipped directly at (661) 257-4411.

IMPORTANT: The 2001 MARS fork is for off road use only and as such, does not come with the reflectors for on road use.

- 1 Never remove or have the steerer tube or stanchions (inner legs) removed from the crown. The steerer tube and stanchions are press fit assembled at the factory. Pressing them out will permanently damage the crown, steerer tube, and stanchions beyond repair and render them unsafe for any continued use.
- 2 Never attempt to thread a threadless steerer tube. Machining threads will weaken the steerer tube and create an unsafe condition. The only safe thing to do is obtain the proper crown/steerer from your dealer.

- 3 Any other alterations or modifications to your fork should be considered unsafe. Contact Answer Products Technical Support prior to modifying your fork in any way for safety information.
- 4 Do not use any Manitou fork if any part appears to be broken, bent, cracked, or damaged. Contact your dealer or Answer Products Technical Support, (661) 257-4411, if you have any questions concerning the integrity, condition, or safe operation of your fork.
- 5 Answer Products recommends that you periodically inspect your fork for wear and damage. Inspect the crown, inner legs, and outer leg dropout and break arch areas for cracks or damage.

III. WARRANTY INFORMATION

Any Answer Products Manitou fork found by the factory to be defective in materials and/or workmanship within one year from the date of purchase will be repaired or replaced at the option of the manufacturer, free of charge, when received at the factory, freight prepaid. This warranty does not cover breakage, bending, or damage that may result from crashes or falls. This warranty does not cover any fork that has been modified, subject to misuse or whose serial number has been altered, defaced or removed. This warranty does not cover paint damage. Any modifications made by the user will render the warranty null and void. This warranty is expressly in lieu of all other warranties, and any implied are limited in duration to the same duration as the expressed warranty herein. Answer Products shall not be liable for any incidental or consequential damages. If for any reason warranty work is necessary, return the fork to the place of purchase. In the USA, dealers should call Answer Products at (661) 257-4411 for a return authorization number (RA#). Instructions for repair, return, or replacement shall be given at that time at. Customers in countries other than USA should contact their dealer or local distributor. For a list of international distributors, visit our website at www.answerproducts.com.

IV. INSTALLATION INSTRUCTIONS

Figures 1 & 2

Ensure that the proper steerer tube length has been delivered on your fork. The steerer tube may need to be cut to length to fit your bicycle head tube. If you are not familiar with this procedure, or do not have the proper tools to cut the steerer tube, it is recommended that you seek a dealer with a qualified bicycle mechanic to perform installation.

Never attempt to thread a threadless steerer tube. Machining threads will weaken the steerer tube and cause an unsafe condition. The only safe thing to do is obtain the proper crown/steerer from your dealer.

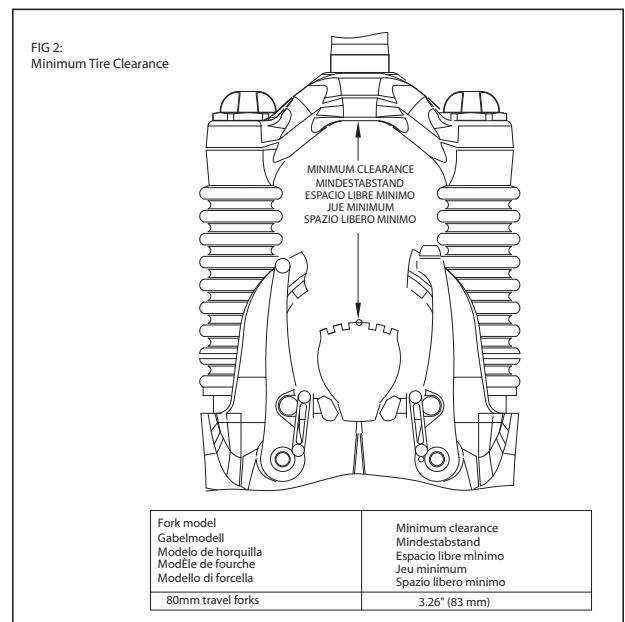
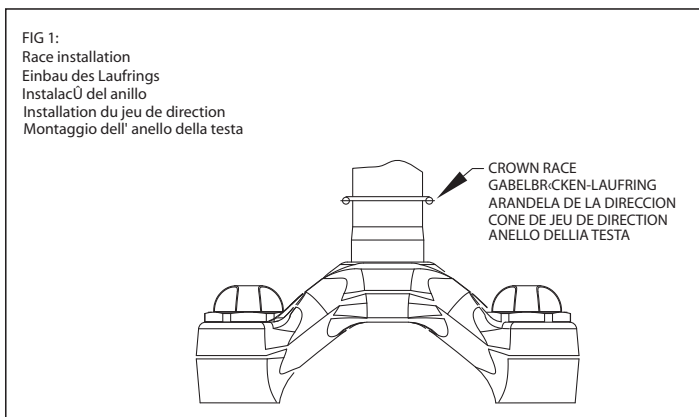

WARNING: The steerer tube and stanchions (inner legs) are a one time precision press fit at the factory and cannot be removed from the crown. Replacement of the entire crown/steerer assembly must be done to change steerer tube diameters or increase length of threaded steerer tubes. Removing and replacing the steerer tube or stanchions will result in an unsafe condition and should never be done.

- 1 Remove old fork from bicycle.
- 2 Measure and cut the steerer tube to fit your bicycle head tube.
- 3 Remove crown race from old fork and press onto 2001 MARS steerer until seated on crown. See Figure 1.
- 4 Clean and grease headset bearing and crown races.
- 5 Install lower bearings on fork crown race.
- 6 Install steerer tube into head tube frame.
- 7 Install upper bearing, spacers, and stem.
- 8 Install handlebars. Torque stem handlebar pinch screw and stem clamping system to manufacturer's instructions.
- 9 Install stem cap, adjust and tighten headset per manufacturer's instructions.
- 10 Install brakes and adjust per manufacturer's instructions. When installing disk brakes, the caliper must fit, or have an adapter to fit, post style mounts with 74mm spacing.
- 11 Adjust front wheel quick release to clear the 0.275 (7MM) thick secondary catch dropout. The quick release must be tightened after it has adequate thread engagement (4 or more threads with the release adjusted to bicycle per manufacturer's specifications).
- 12 Install brake cable per manufacturer's instructions. Route disk brake lines so that they will not kink or be pinched through the full travel of the fork.
- 13 Check tire clearance with crown. Figure 2.

Note: All 2001 MARS forks are equipped with a secondary catch dropout.

WARNING: When installing the wheel or any new tire, check the minimum tire clearance. Measure from the highest point on the tire to the bottom of the crown. The minimum clearance allowed 3.26 (83mm) for 80mm travel fork models. Any less clearance can result in accident resulting in serious injury or death. See Figure 2

CYCLE COMPUTER INSTALLATION INSTRUCTIONS:

Follow the instructions in your owner's manual with the following exceptions:

WARNING: DO NOT DRILL A HOLE IN THE DROPOUT. THIS MAY WEAKEN THE DROPOUT, WILL VOID THE WARRANTY, AND MAY CAUSE AN UNSAFE CONDITION WITH RISK OF INJURY OR POSSIBLE DEATH.

V. SUSPENSION SETUP:

- If the fork is new, break it in with at least one hour of riding before making any changes.
- Make sure the fork is in good working condition and is properly serviced and lubricated.
- Make changes in small increments.
- Keep a record of all changes made for future reference.

ADJUSTING RIDE QUALITIES:

2001 MARS forks offer a wide adjustment range to suit individual riding preference and rider weight by simply changing the air pressure and spring rate.

Compression Spring Fine-Tuning

Fine tuning adjustments are made by adjusting the air pressure and changing the spring. Use the chart below as a starting point for finding the proper air spring based on rider weight.

Recommended Spring Rates for 2001 MARS Forks

Rider Weight	Air Spring	Coil Spring
under 115 lbs.	80 psi +/- 5psi	(1) 3 blue 80 pound coil spring
115-145 lbs.	100 psi +/- 5psi	(1) 3 red 100 pound coil spring
145-175 lbs.	120 psi +/- 5psi	(1) 3 red 100 pound coil spring
175-205 lbs.	140 psi +/- 5psi	(1) 3 yellow 120 pound coil spring
205-230 lbs.	160 psi +/- 5 psi	(1) 3 yellow 120 pound coil spring
230 + lbs.	180 psi +/- 5 psi	(1) 3 black 150 pound coil spring

Air/coil spring rate tuning

All 2001 MARS forks use a combination of air and a coil spring. The air spring is adjustable via a Schraeder valve located on top of the left leg. See Figure 3. The positive coil spring can also be switched with stiffer or softer versions to accommodate for different rider styles and terrain. There's also a coil negative spring, but it is available in one rate only and is designed to be pre-loaded automatically as the positive air spring pressure is increased (in other words, you don't need to do anything to tune it).

Compression Damping Tuning:

To adjust the MARS Elite: Figure 3

Simply rotate the compression-damping knob located on top of the right leg and crown. Rotating the knob clockwise will increase the damping, rotating the knob counter clockwise will reduce the damping. Excessive damping will give you a harsh ride over sharp bumps like rocky sections, but will feel good in large hits like G-outs. Insufficient compression damping will bottom out in the large hit G-outs and bob a little while climbing but feel plush on the sharp hits.

To adjust the MARS Super: Figure 4

Remove the Anti-Bob compression damping assembly from the top of the right leg. Adjust the setscrew on the valve seat in to increase compression damping and out to reduce the compression damping. Try adjusting one half turn at a time.

Note: Compression and rebound damping on the MARS is factory pre set.

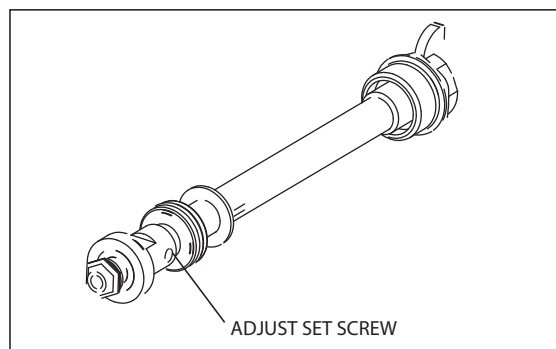
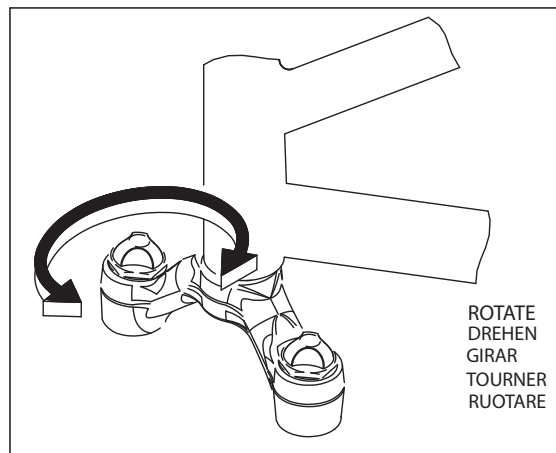

Rebound Damping Fine Tuning: Figure 5

To adjust the MARS Elite and MARS Super Simply rotate the rebound-damping knob located on bottom of the right leg. Rotating the knob clockwise will increase the damping, rotating the knob counter clockwise will reduce the damping. Excessive rebound damping will give you a harsh ride over repetitive bumps (like braking bumps) because the fork will pack up. Insufficient rebound damping will make the fork overactive, top out and slap back when landing from a jump. We suggest that you try adjusting your fork on the active side with minimum rebound. Then try it over a variety of terrain and tune in more rebound from there.

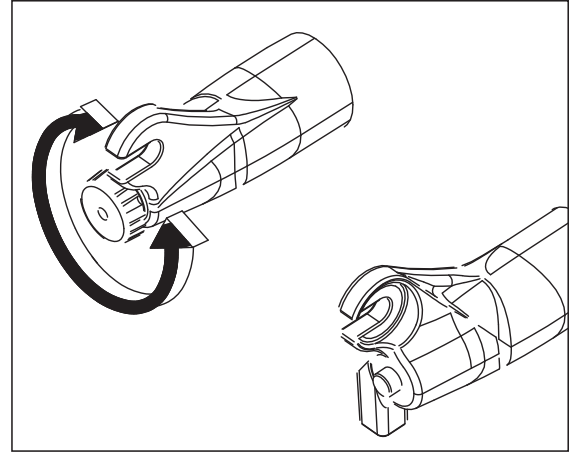

For additional tuning tips we recommend that you obtain a copy of the MRD tuning Manual P/N 85-3696 (download from the web at www.answerproducts.com) and check out the MRD Race Tuning kits available at your dealer.

VI. TROUBLE SHOOTING

Fork seems to top out or has a slight clunking feel when front wheel comes off the ground: Excessive preload or insufficient rebound damping will result in a top out. Select spring's that better fit your weight and riding style, set the air pressure to a mid to low range, and increase the rebound damping to eliminate top out.

The fork feels less active and is not getting the travel it used to when it was new: Chances are that the fork is developing stiction. Cleaning Microlube and applying light oil to the stanchions should eliminate the problem.

Outer legs feel loose on inner legs and bushings, a knock or rock can be felt when pushed from side to side: A very minute knock is normal with the new harder bushings. If the knock is excessive or you can feel the fork rocking then the bushings should be removed and replaced. To do this contact Answer Products or an authorized Manitou Dealer.

A small amount of oil seems to be leaking from top of the right leg at the adjuster cap: If you store the 2001 MARS Fork upside down for a extended period of time a small amount of oil may leak through the adjuster cap / knob assembly. The cap area is not subjected to damping pressure under normal use. So you will not see any leakage with the fork right-side up.. A small leak in that area will not affect the performance of the fork or cause any type of damage. We recommend that you store your Manitou right side up. If this condition causes any problems please contact your Answer Products dealer or call our warranty tech department for prompt service.

VII. MAINTENANCE

IMPORTANT: The 2001 MARS should not be used if any parts appear to be, or are damaged. Contact your local dealer or Answer Products for replacement parts.

IMPORTANT: Use of fork boots is recommended to keep your MARS fork performing at its optimum for extended service cycles, and maintaining maximum life of fork. Use of this fork without fork boots will require frequent service intervals to maintain performance and normal life of fork. Warranty will be void if fork is found to show that boots were not in place and frequent service was not performed.

MICROLUBE

All 2001 Manitou forks come standard with the MicroLube lubrication system. Located at the back of the fork is a small fitting that is the heart of the MicroLube system. This is where you inject grease. The major benefits of the MicroLube system are that it is lightweight and effective. Only a small quantity of grease is needed to properly lubricate the fork, and the fitting for injecting grease puts it just where it needs to be. MicroLube also greatly decreases the time you have to spend servicing your fork because you can regrease the fork without disassembly. With MicroLube, you can simply grease your fork as needed, and that's what we recommend. If you feel any stiction developing with your fork, give about 10 squirts with Prep M lube. Push the fork up and down a few times to ensure that the lube penetrates properly and the go ride.

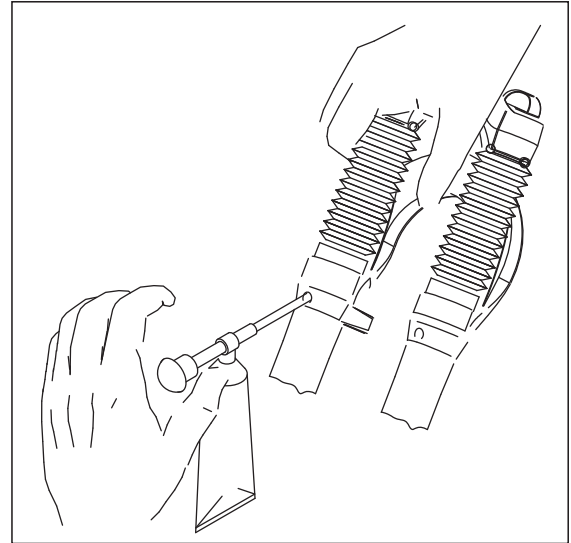

Your 2001 MARS Fork requires periodic maintenance, cleaning, and inspection. Moisture and contamination may build up inside the fork depending on the severity of riding conditions. To maintain top performance, it is recommended that the fork be periodically disassembled, cleaned, dried and re-greased using Prep-M grease. See Figure 6.

IMPORTANT: When filling the fork with grease through the MicroLube grease ports it is important to note the grease is being forced between the upper and lower bushing. If the area is overfilled the force of the grease may force the upper bushing and dust seal out.

TPC OIL LEVEL

IMPORTANT: Maintaining the proper oil level in your TPC is very important. Not enough oil will allow foaming and reduce the performance. Too much oil will restrict travel and may cause damage to the system and an unsafe riding situation. Finish reading this entire section prior to making any changes to the oil level.

To check the oil level: remove only the compression damping assembly located in the top of the right leg. Leave the left side spring stack (air spring) in place to keep the fork fully extended. Use a tape measure or dip stick to determine the oil level. The recommended

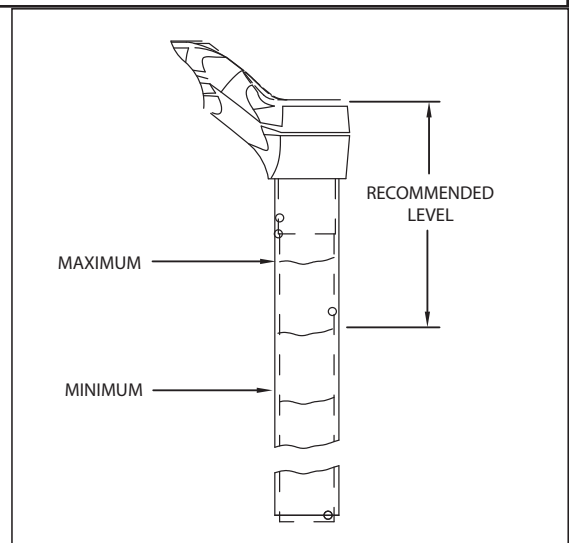

level is different for each model See Figure 7. It is recommended that you replace your oil at least once during the year, twice if it has been contaminated with dirt, mud, or other foreign substance. Use SAE 5WT Maxima fork oil or equivalent.

IMPORTANT: Before every ride you should:

- 1 Ensure that the quick release skewers are properly adjusted and tight.
- 2 Check the entire fork for any obvious damage.
- 3 Check headset adjustment.
- 4 Ensure that the front brake cable is properly seated in the cable retainer & check brake adjustment.

NOTE: The Fork does not need to be removed from the bicycle for general disassembly-assembly or cleaning. In addition, coil spring replacement is accomplished by removal of outer leg/arch assembly.

INNER FORK LEGS & CROWN

The inner fork legs and steerer tube are press fit into the crown and may never be removed. Removing them will make the fork unsafe to use. If you see any slippage contact Answer Technical Staff immediately (800) 670-7446.

REMOVAL OF OUTER LEG / ARCH ASSEMBLY:

- 1 Use a 4MM Allen wrench to remove the lower compression rod screw from the left leg dropout. Pop out the damping adjuster knob from the right dropout. A small screwdriver may be helpful. Use an 8MM allen wrench to remove the dropout nut. Fully compress the fork if needed to prevent the compression rod and damper shaft from turning while removing screws.
- 2 Pull the outer leg assembly down to remove from the inner legs and crown.
- 3 Remove fork boots.

Note: It is not recommended to remove the dust seal every time the fork is disassembled. The seal and bushings should be cleaned and re-greased in place.

INSPECTION

- 1 Check the dust seal for tears, wear, or damage. Replace if needed.
- 2 Inspect the lower and upper bushing for damage to the Teflon coating. Replace by calling Answer Products or an authorized Manitou dealer.
- 3 Check the outer leg/arch assembly for nicks or deep gouges on outside and inside. Replace if damaged.
- 4 Remove boots and check the inner legs for deep gouges and other damage. Minor wear resulting in color change is not detrimental to the gold anodized surface. Replace if wear is excessive or if inner legs are damaged.
- 5 Check inner legs at the bottom of the crown for cracks or for flaking anodize. Replace crown steer leg assembly if cracked or if gold anodize is beginning to flake.
- 6 Check the underside of the crown for cracks. Replace if cracked.

OUTER LEG REASSEMBLY:

- 1 Reinstall boots.
- 2 Slide outer leg / Arch assembly onto inner legs and fully compress.
- 3 Install and torque 4mm compression rod screw and 8mm dropout nut to 10-30 inch-lb. (1.1-3.5 N-m). Over torquing the dropout nut may damage the damper shaft.
- 4 Grease o-ring, pop in damper adjuster knob. O-ring holds knob in place.
- 5 Slide skirt of fork boots onto the dust seal. Be sure the lip snaps into the groove.
- 6 Lubricate the fork using the MicroLube system and Prep M grease. See page 4 Maintenance.

COMPRESSION STACK, BOOTS, & COMPRESSION ROD REMOVAL:

- 1 Remove outer leg assembly.
- 2 Slide fork boots off of inner legs.
- 3 Press the bottom clip off the compression rod.
- 4 Slide off the bottom out elastomer from left leg compression rod.
- 5 Using a 15/16 wrench or socket unscrew the left inner leg cap. Then remove the compression rod, elastomer and push rod.

AIR SPRING DISASSEMBLY:

- 1 Remove compression rod.
- 2 Let air out of air spring and remove top cap.
- 3 Push piston out top of left leg, with a 1/2 or smaller rod. Push through the center of the air piston stop. (Air piston stop is not removable).

COMPRESSION ROD & AIR SPRING INSPECTION

1. Check the compression rod for obvious damage.
2. Check the fork boots for obvious damage.
3. Check all springs for obvious damage. Replace if necessary
4. Clean and inspect piston and seals, replace if seals are worn, nicked or torn.
5. Check all other parts for obvious damage, replace if necessary.
6. Replace all seals that have been removed.

COMPRESSION ROD & BOOTS REASSEMBLY:

1. Clean all parts thoroughly.
2. Grease compression rod lightly. Be sure rebound elastomer is installed onto compression rod.
3. Slide on end cap, second stage elastomer, and install bottom clip.
4. Install into left leg. Torque to 10-20 in-lbs (1.1-2.5 N-m).
5. Slide boots onto inner leg.

AIR SPRING REASSEMBLY:

1. Grease piston seals and threads in top of left leg.
2. Push the piston into the leg with the smaller hole facing down. Make certain piston is straight and gently rock it back and forth while pushing down until it is past threads.
3. Install compression rod as described above.
4. Install outer leg assembly as described in section 10.
5. Pour 2.5 CC of 40-wt oil on top of air piston.
6. Install air cap, pressurize system and install knob.

WARNING: Do not fill air spring with more than 190 psi.

REBOUND DAMPER DISASSEMBLY:

Note: Disassembly of the damping stack is not required unless you want to change or replace the shim stack.

1. Remove outer leg assembly.
2. Remove the right compression damping assembly from the top of the right fork leg and pour the oil out of the top of the fork and discard appropriately.
3. Using a 15/16 open end wrench or socket, unscrew the plastic end cap and pull the lower shaft out of the inner leg.

Note: Steps 4-8 apply to MARS Elite and MARS Super only.

4. Remove the clear plastic detent sleeve and capture the 1/8 dia. detent ball.
5. Adjuster needle may be unscrewed from the shaft.
6. Remove the retaining ring then slide off the cup washer, & bottom out bumper. Do not remove the threaded plastic end cap at this time. Sliding the seal over the retaining ring groove may damage the seal.
7. Clamp shaft in soft jaws or collet and remove piston as a complete unit, slide end cap off of top of shaft.
8. Remove the valve nut and disassemble damping stack, make note of the exact order of the shims and spacers.

REBOUND DAMPER INSPECTION

1. Check the shaft for scratches, wear, or other obvious damage.
2. Check the seal gland and end cap seal grooves for damage.
3. Check shims for permanent bends or damage.
4. Check all other parts for obvious damage, replace if necessary.
5. Replace all seals that have been removed.
6. Clean shims using lint free rags or paper towels.

MARS REBOUND DAMPER ASSEMBLY

1. Install all o-rings and seals that you removed.
2. Grease all seals lightly with seal grease.
3. Insert into right leg and thread in end cap. Torque 30 in-lb. (3.5N-m) max.
4. Install outer leg assembly, see Figure 9. Add 5 WT Maxima or equivalent oil. Do not over fill. Check oil level, see Figure 8.

MARS ELITE AND MARS SUPER REBOUND DAMPER ASSEMBLY:

1. Install all o-rings and seals that you removed.
2. Grease all seals lightly with seal grease.
3. Assemble shim stack and spacers onto the piston seat in exact order that they were removed. Apply a small amount of blue Loc-tite to piston seat threads install and hand tighten nut. Be sure large blow off washer will slide over piston spacer and compress the small spring. Torque 12 in-lb. (1.3 N-m) max, over tightening will damage the piston.
4. Apply a small amount of blue Loc-tite to piston seat threads. Install piston seat into shaft. Use wrench flats on piston seat to torque piston seat to 30 in-lb. (3.5 N-m) max.
5. Install lower needle gently into shaft; thread until it stops then back off two turns for initial adjustment.
6. Slide shaft assembly through the plastic end cap, slide on 2nd STG Elastomer, cup washer and snap ring, place detent ball in place and slide clear detent sleeve over it.
7. Insert into right leg and thread in end cap. Torque 30 in-lb. (3.5N-m) max.
8. Install outer leg assembly ,see Figure 9.Add 5 WT Maxima or equivalent oil. Do not over fill. Check oil level, see Figure 8.

COMPRESSION DAMPER DISASSEMBLY:

MARS Elite

1. The compression damping assembly is almost identical to the lower shaft assembly. Remove compression damping assembly from top of right leg.
2. Unscrew the compression damping adjuster all the way until it stops. The knob and the needle do not need to be removed. The shaft also does not need to be removed from the cap. The threads are bonded to prevent leaking.
3. Do not remove piston assembly from shaft. Remove the valve nut and disassemble damping stack, make note of the exact order of the shims and spacers.

MARS Super.

1. The Anti-Bob compression-damping shaft is assembled in a fixture at the factory to assure proper alignment of the pistons and should not be disassembled.

COMPRESSION DAMPER INSPECTION

1. Check the cap o-ring, all models, and piston o-ring Anti-Bob only for damage.
2. Check shims for permanent bends or damage.
3. Check all other parts for obvious damage, replace if necessary.
4. Replace all seals that have been removed.

COMPRESSION DAMPER REASSEMBLY

MARS Elite

1. Assemble shim stack and spacers onto the piston seat in exact order that they were removed. Refer to Figure 15. Apply a small amount of blue Loc-tite to piston seat threads. Install and hand tighten valve nut. Be sure large blow off washer will slide over piston spacer and compress the small spring. Torque valve nut to 12 in-lb. (1.3 N-m) max, over tightening will damage the piston.
2. Install compression damping assembly into the right leg. The oil level should cover the compression valve when the assembly is installed. See figure 7.

MARS Super

1. Lightly grease the o-rings and threads on the Anti-Bob. With the Anti-Bob open, install the Anti-Bob into the right side leg (Be careful as you do this to avoid damaging the lower rubber o-ring. The fit should be tight, so SLOWLY twist the Anti-Bob as you slowly lower it in the leg. Do not use the Anti-Bob on-off knob to turn the assembly when tightening.
2. Once the Anti-Bob assembly is firmly in place, flip it to the closed position and while holding the front brake, compress the fork. It should only move a very small amount and the Anti-Bob should feel firm. Remember that there is a safety blow off which allows the fork to move under extreme bump forces (when closed), so if you push it very hard, you will see more than a few millimeters of movement. If at the end of installation, the Anti-Bob does not function properly, remove the Anti-Bob and check O-ring for tearing.
3. If you think youve done everything right and the Anti-Bob is still not functioning properly, remove the compression assembly and recheck the oil height.

SPARE PARTS:

Table 1

Spare parts can be ordered through your local dealer. If you have any problems that you cannot resolve with your dealer, you may call Answer Products Technical / Warranty Service Department at (661) 257-4411, 8:00 AM to 5:00 PM, Pacific Standard Time, Monday through Friday.

DESCRIPTION	PART NUMBER
MARS, MARS ELITE & MARS SUPER SOFT RIDE KIT	85-9187
MARS, MARS ELITE & MARS SUPER FIRM RIDE KIT	85-9188
MARS, MARS ELITE & MARS SUPER X-FIRM RIDE KIT	85-9226
MARS, MARS ELITE & MARS SUPER BLACK OUTER ASSEMBLIE	85-9192
MARS, MARS ELITE & MARS SUPER YELLOW OUTER ASSEMBLIE	85-9195
MARS, MARS ELITE & MARS SUPER RED OUTER ASSEMBLIE	85-9203
MARS, MARS ELITE & MARS SUPER BLUE OUTER ASSEMBLIE	85-9204
MARS, MARS ELITE & MARS SUPER WHITE OUTER ASSEMBLIE	85-9205
MARS BLACK STICKER KIT	85-4128
MARS RED/WHITE STICKER KIT	85-4129
MARS ELITE STICKER KIT	85-4130
MARS SUPER RED STICKER KIT	85-4132
MARS, MARS ELITE & MARS SUPER STEER TUBE/LEG ASSEMBLY	85-9213
MARS, MARS ELITE & MARS SUPER BUSHING SEAL KIT	85-4111
MARS REBOUND DAMPING ASSEMBLY	85-3016
MARS ELITE & MARS SUPER REBOUND DAMPING ASSEMBLY	85-9268
MARS COMPRESSION DAMPING ASSEMBLY	85-3018
MARS ELITE COMPRESSION DAMPING ASSEMBLY	85-3014
MARS SUPER COMPRESSION DAMPING ASSEMBLY	85-4062
MARS, MARS ELITE & MARS SUPER AIR CAP/PISTON ASSEMBLY	85-3033
MRD TUNING MANUAL	85-3696
MICROLUBE TUBE/GREASE GUN	85-3810
FORK PUMP	85-4069
ANTI-BOB KIT	85-4062
ANTI-BOB SEAL KIT	85-3686



28209 AVENUE STANFORD • VALENCIA, CA 91355
(661) 257-4411 • www.answerproducts.com

BUSHING & SEAL DETAIL

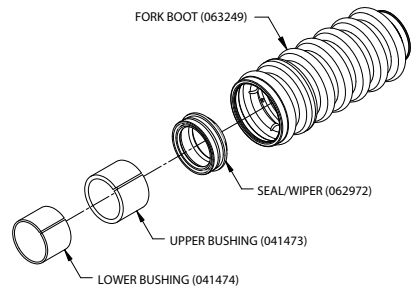

2001 MARS FORK SCHEMATIC

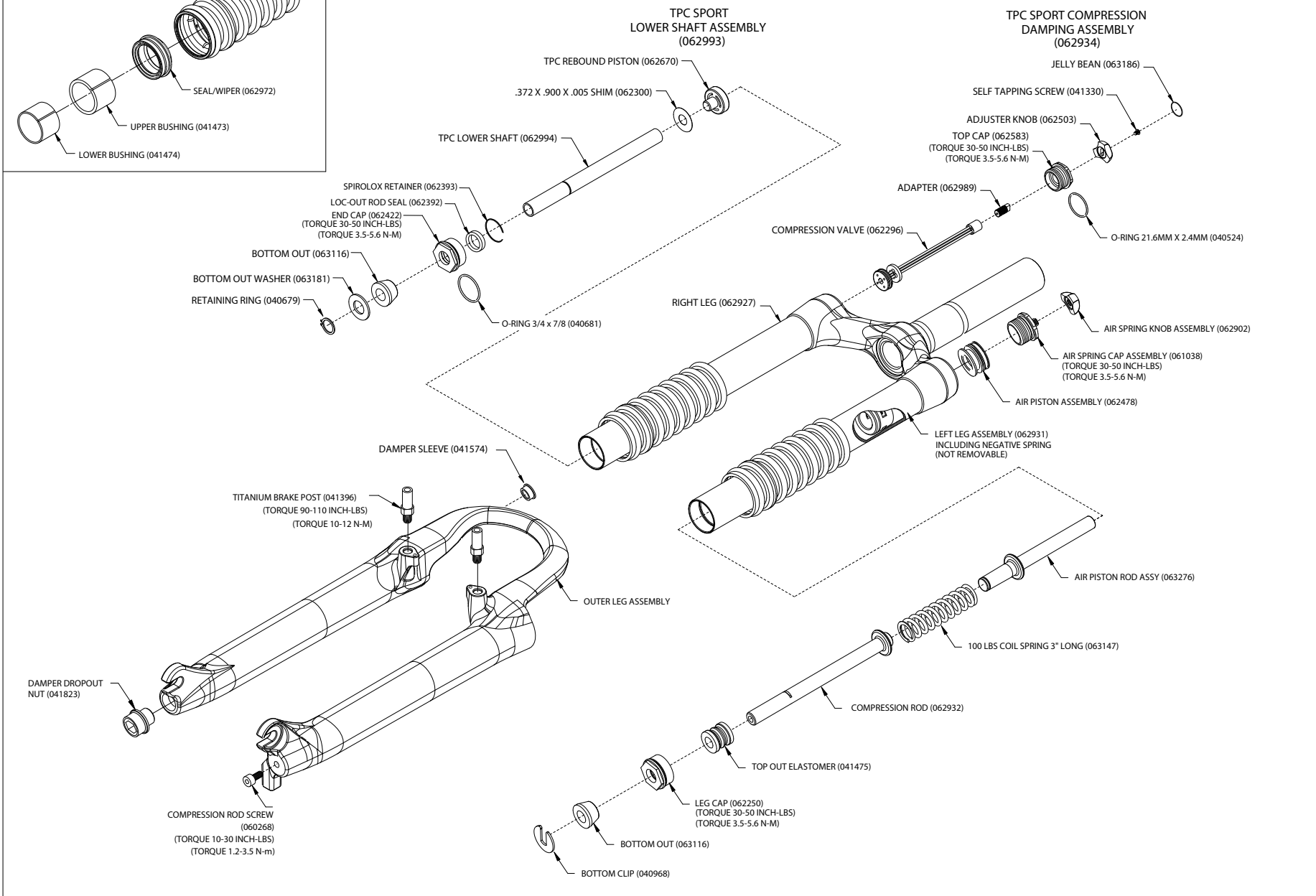

BUSHING & SEAL DETAIL

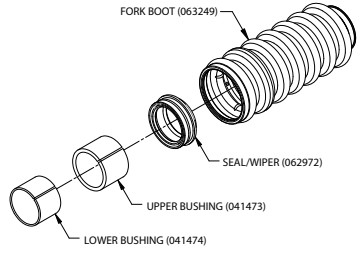

2001 MARS SUPER FORK SCHEMATIC

