



**SABRE**



# **ELSA DASH/SPRINT**

**Compressed Air Escape Breathing Apparatus**

**User Instructions**



Article No. 1034931  
Issue G 01. 2007

**CE 0086**

# ELSA Dash/Sprint

## Compressed Air Escape Breathing Apparatus

### Contents

<b>WARNINGS</b> .....	<b>ii</b>
<b>1. INTRODUCTION</b> .....	<b>1</b>
1.1 BREATHABLE AIR .....	1
1.2 APPARATUS SELECTION .....	1
1.3 TRAINING.....	1
1.4 SERVICING .....	1
1.5 SHELF LIFE .....	1
1.6 USE IN EXPLOSIVE OR FLAMMABLE ATMOSPHERES.....	2
1.7 TRANSPORTATION.....	2
<b>2. TECHNICAL DESCRIPTION</b> .....	<b>2</b>
2.1 GENERAL.....	2
2.2 HOODS (DASH/SPRINT) .....	3
2.3 FACEMASKS (SPRINT).....	3
2.4 REDUCER VALVE (DASH/SPRINT).....	4
2.5 DEMAND VALVE (SPRINT).....	4
2.6 CYLINDER VALVES (DASH/SPRINT).....	4
2.7 STORAGE BAG.....	5
2.8 QUALITY ATTRIBUTES .....	5
<b>3. INSTRUCTIONS FOR USE</b> .....	<b>5</b>
3.1 INITIAL CHECKS.....	5
3.2 DONNING .....	5
3.3 HOOD (DASH/SPRINT) .....	6
3.4 FACEMASK (SPRINT) .....	7
<b>4. AFTER USE CLEANING AND TESTING</b> .....	<b>7</b>
4.1 CLEANING HOODS (DASH/SPRINT) .....	7
4.2 CLEANING FACEMASKS .....	8
4.3 CHANGING CYLINDERS .....	8
4.4 BREATHING APPARATUS LOG .....	9
4.5 STOW APPARATUS.....	9
4.6 WORKSHOP REPAIR AND ANNUAL SERVICING .....	10
<b>5. SCHEDULED MAINTENANCE</b> .....	<b>10</b>
5.1 GENERAL.....	10
5.2 DAILY CHECKS.....	10
5.3 MONTHLY CHECKS .....	10
5.3.1 Check Apparatus .....	10
5.3.2 Upon Completion .....	11

**Sabre Breathing Apparatus** is a division of **Scott Health and Safety Limited**.

**Registered Office:** Scott Health and Safety Limited, Pimbo Road, West Pimbo, Skelmersdale, Lancashire, WN8 9RA, United Kingdom.

# WARNINGS

## Please Read Carefully and Fully Understand

This manual is for use by personnel trained in the use and care of compressed air escape apparatus and **MUST NOT** be used as a self-teaching guide by untrained users.

**Scott Health and Safety Limited** have taken great care to ensure that the information in this manual is accurate, complete and clear. However, **Training and Technical Support Services** will be pleased to clarify any points in the manual and answer questions on **Sabre** breathing apparatus.

**If you need to use this apparatus you will be in an unusual, possibly life-threatening situation. Poor visibility and toxic fumes may add to your difficulties.**

**Prepare for that situation:**

- Learn the location of escape apparatus and how to gain access to it.
- Learn to use the escape apparatus, as detailed in these instructions.
- Be aware of the protection limits provided by ELSA apparatus. Exceeding these limits may cost you your life or result in injury.
- Be fully aware of workplace hazards.
- Become familiar with planned escape routes.

**If the situation arises:**

- Remain calm and remember what you must do to survive.
- Don and activate the apparatus. Leave the hazard area immediately.
- Do not enter a hazard area unless it is part of the escape route.
- Ensure that clothing, hair, spectacle frames or other items that might prevent a good seal being achieved, do not intrude into the facepiece seal.

**General and Managerial:**

- Check apparatus daily when issued to wearers or deployed in ready-use lockers; or monthly if held in stores.
- ELSA Dash and Sprint are escape apparatus. **DO NOT** use for other purposes such as fire fighting or cargo handling.
- Ensure wearers are fully trained in the use of the apparatus, advised of work place hazards and planned escape routes.
- Ensure ELSA apparatus provide suitable respiratory protection for workplace hazards and has duration for planned escape routes.

**Refer to EN 529 : 2005 - *Guide to implementing an effective respiratory protective device programme.***

### DISCLAIMER

Failure to comply with these instructions or misuse of the apparatus may result in death, injury or material damage, and invalidate any resulting warranty or insurance claims.

### COPYRIGHT

This manual must not be copied in part or in whole, or used for purposes other than its intended purpose without the written permission of **Scott Health and Safety Limited**.

## 1. INTRODUCTION

### 1.1 BREATHABLE AIR

Air for compressed air breathing apparatus may be natural or synthetic. A typical composition of natural air (at atmospheric pressure and room temperature) is shown in *Table 1*.

Element	Mass % (Dry Air)	Volume % (Dry Air)
Oxygen	23.14	20.948
Nitrogen	75.52	78.08
Argon	1.29	0.93
Carbon Dioxide	0.05	0.031 4
Hydrogen	0.000 003	0.000 05
Neon	0.001 270	0.001 818
Helium	0.000 037	0.000 524
Krypton	0.000 330	0.000 114
Xenon	0.000 039	0.000 009

**Table 1: Breathable Air**

The quality of air used to supply and charge breathing apparatus must conform to EN 12021 : 1999 (*Requirements for Breathable Air*).

Fire risk increases when the oxygen level rises above the value shown in *Table 1*.

Contaminants must be kept to a minimum, and must not exceed permissible exposure levels.

Cylinder water content of air at atmospheric pressure must not exceed 50 mg/m<sup>3</sup> for 200 bar cylinders or 35 mg/m<sup>3</sup> for 300 bar cylinders.

National regulations for compressed air breathing apparatus must be observed.

### 1.2 APPARATUS SELECTION

When selecting respiratory protective equipment the following factors must be considered:

- Hazards likely to be encountered and their effect on the wearer.
- Physical and emotional stress and their effect on wearer breathing rate.
- The type of respiratory protection required.

In general, constant flow escape breathing apparatus is NOT suitable for use where:

- There are unknown hazards.
- There are no planned escape routes.
- There are escape routes that require physical exertion, e.g.: ladders, tunnels and hatches.

### 1.3 TRAINING

These instructions cannot replace an accredited training course run by fully qualified instructors in the proper and safe use of **Sabre** breathing apparatus.

Please contact **Training and Technical Support Services** or your **Sabre** distributor for training course details.

#### **Training and Technical Support Services:**

**Scott Health and Safety Limited**  
Pimbo Road, West Pimbo,  
Skelmersdale, Lancashire,  
WN8 9RA, United Kingdom.

**Tel: +44 (0) 1695 711711**

**Fax: +44 (0) 1695 711775**

### 1.4 SERVICING

**ELSA** apparatus must be serviced by personnel who have completed a formal training course and hold a current certificate for servicing and repairing **Sabre** breathing apparatus. Details of the servicing schedule are contained in the **ELSA Dash** and **ELSA Sprint** Service Manuals, copies of which can only be obtained by registered holders of a current certificate.

Your **Sabre** distributor or **Training and Technical Support Services** will be pleased to provide training course details and quotes for service contracts. Please see previous page for contact details.

### 1.5 SHELF LIFE

Providing that **ELSA** apparatus is serviced regularly as described in the **ELSA Dash** and **ELSA Sprint** Service Manuals, there are no shelf life limitations.

## 1.6 USE IN EXPLOSIVE OR FLAMMABLE ATMOSPHERES

Anti-static versions of **ELSA** apparatus are approved for use in explosive and flammable atmospheres. Anti-static apparatus is provided in a black bag. Apparatus with a high-visibility orange bag **MUST NOT** be used in explosive or flammable atmospheres.

## 1.7 TRANSPORTATION

It is essential that **ELSA Dash** and **ELSA Sprint** are transported in suitably protective packaging.

Refer to the Health and Safety document: *Guide to the Pressure Systems and Transportable Gas Container Regulations 1989*. When breathing apparatus with charged cylinders is transported by road, the *Road Traffic Regulations 1986*, although primarily intended to cover toxic, flammable and corrosive gases, should be observed.

After transportation, apparatus must be checked to ensure that:

- The bag and contents gauge have not been damaged.
- The anti-tamper tag is intact.

## 2. TECHNICAL DESCRIPTION

### 2.1 GENERAL

**ELSA Dash** and **ELSA Sprint** are self-contained, open circuit, compressed air, short duration, positive-pressure, escape breathing apparatus that may be stored ready-for-use within a hazardous area or carried by the wearer while in a hazardous area.

**Dash** is a constant flow apparatus with a flow rate of 38 litres per minute; that consists of a compressed air cylinder with a pressure reducing valve (reducer), cylinder valve, and hood, contained in a high-visibility bag, or black anti-static bag.

**Sprint** is similar to **Dash**, but has a two-stage pressure reduction system that consists of the reducer and a facepiece-mounted demand valve. The **Sprint** facepiece may be a hood or a full facemask.

Both **Dash** and **Sprint** are available in ten and fifteen minute versions, with a two litre or three litre aluminium cylinder.

Pictogram user instructions and the duration of the air supply are prominently visible on the bag.

An anti-tamper tag, (that breaks easily when the bag is opened), provides an indication that the bag has been opened. When the apparatus is first delivered, tags are provided separately, with instructions for fitting, permitting the contents of the bag to be checked. Tags must then be fitted prior to deploying the bag.

The quick-fire cord is attached to the bag lid and wound around the cylinder valve handwheel. When the lid is opened the cord turns the cylinder valve handwheel and air immediately flows into the hood.

If the valve does not open when the bag is opened, the cylinder valve handwheel can be used to open the valve.

The cylinder contents gauge is visible through a transparent panel in the bag, thereby permitting the cylinder charge state to be checked without opening the bag.

Providing the apparatus is serviced regularly in accordance with the service requirements, detailed in the **ELSA Dash**, or **ELSA Sprint** Service Manual, there are no shelf life limits.

**Dash** and **Sprint** must be stored away from direct heat and sunlight. They can be stored and operated between -15°C and +60°C. Prior to storing in very low temperatures the apparatus, especially the exhale valve flap, must be completely dry.

## 2.2 HOODS (DASH/SPRINT)



**Hood**

The hood has an inner mask to minimise visor misting and carbon dioxide dead space. A spring-loaded exhale valve helps maintain a positive pressure within the facepiece.

Hoods are fabricated from high-visibility, flame-resistant materials with a rubber neck seal.

In addition to the standard hood, an 'EZ Clean' (easy-clean) version is available which is fabricated from a more durable material.

## 2.3 FACEMASKS (SPRINT)

**Sprint** is approved for use with **PanaSeal**, **Vision 3** and **Promask PP** full facemasks. All facemasks are moulded in non-dermatitic material and can be supplied with five point elastic or neoprene head harnesses.



**PanaSeal Facemask**



**Vision 3 Facemask**



**Promask PP Facemask**

# ELSA DASH/SPRINT

## 2.4 REDUCER VALVE (DASH/SPRINT)

The reducer is a simple, automatic spring and piston device, which screws into the charging adaptor of the cylinder valve and must be removed to charge the cylinder. It is attached to the cylinder using the handwheel.

It provides an output pressure of between 5.5 and 9.5 bar with a maximum flow rate of 300 L/min.

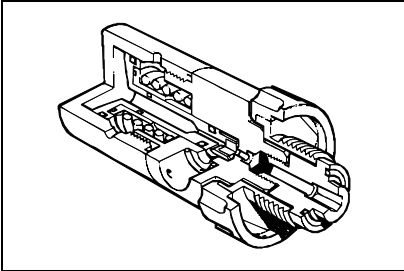

The medium pressure system is protected by a pressure relief valve (PRV) located in the reducer which opens when pressure in the reducer rises above 9.5 bar.

## 2.5 DEMAND VALVE (SPRINT)

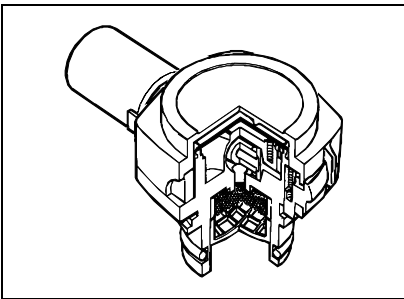

**Instant Positive Pressure DV**

The demand valve employs a servo assisted, tilting diaphragm to regulate the supply of air into the facepiece. It operates in conjunction with the spring-loaded exhale valve to maintain a positive pressure within the facepiece.

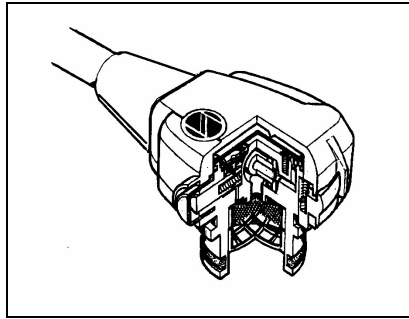

**First Breath DV**

The demand valve is available with a first breath actuation mechanism that becomes active when the wearer takes a first breath; or with instant positive pressure where air is available as soon as the cylinder valve is opened.

Demand valves with a first breath mechanism have a black cover, while instant positive pressure demand valves have an orange cover.

First breath mechanism demand valves have a black rubber reset button which, when pressed, closes the demand valve. This permits the demand valve to be removed from the facepiece for testing or at the end of an escape. Once reset the demand valve is opened by the wearer inhaling sharply.

## 2.6 CYLINDER VALVES (DASH/SPRINT)

The cylinder valve has a handwheel-operated slug which closes the valve.

The charging port is a DIN 477 type A.

The contents gauge, which indicates the cylinder charge level, has three coloured sectors: green (fully charged), orange (safe to use but will not provide the full duration) and red (Empty - DO NOT USE).

A burst disc is fitted, which blows if the cylinder charge exceeds 300 bar, and in the event of damage to the gauge, a restrictor limits air loss to 25 L/min.

## 2.7 STORAGE BAG

The standard bag is fabricated from high visibility lightweight material. A bag fabricated from black anti-static material is also available. The fully-adjustable carrying strap enables the wearer to wear the bag across the chest or under the right arm.

## 2.8 QUALITY ATTRIBUTES

**ELSA Dash** and **Sprint** are approved to:

- EN 402 : 1993 (*Respiratory protective devices for escape*).
- Lloyds Register SOLAS 74, Certificate No. SAS F970054

Facemasks are approved to EN 136.

**Dash** and **Sprint** are 'CE' marked in accordance with EEC Directive EC/686/1986.

**Sabre Breathing Apparatus** is an ISO9001 : 2000 approved division of **Scott Health and Safety Limited**.

### NOTIFIED BODIES:

Inspec International Ltd (No. 0194)  
Upper Wingbury Courtyard,  
Wingrave, Aylesbury,  
Buckinghamshire,  
HP22 4LW,  
United Kingdom.

British Standards Institute (No. 0086)  
389 Chiswick High Road,  
London,  
W4 4AL,  
United Kingdom.

## 3. INSTRUCTIONS FOR USE

### 3.1 INITIAL CHECKS

When issued to a wearer and prior to each use, the wearer must check that:

- The anti-tamper tag is in place.
- The contents gauge shows that the cylinder is full.

### 3.2 DONNING



1. Pass the carrying strap around the neck so that the bag hangs across the front, or under the right arm.



2. Open the bag and check that the quick-fire cord has opened the cylinder valve.



# ELSA DASH/SPRINT

---



3. If the quick-fire cord is not fitted, turn the cylinder valve handwheel fully anti-clockwise to open the valve.

## CAUTION:

- Ensure that finger nails and rings do not snag or tear the neckseal.
- Do not roll or fold the neckseal when donning the hood.

## 3.3 HOOD (DASH/SPRINT)

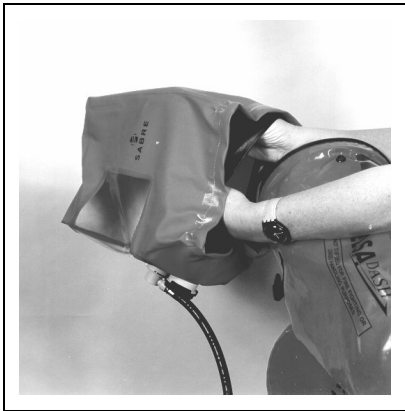

1. Pull out the hood, insert hands (palms together) into the neckseal and stretch the neckseal.



2. Hold the hood with the neck seal over the crown of the head and pull the hood down over the head until the neck seal is around the neck.



3. Position the mask over the face for a good fit.

4. Breathe normally. LEAVE THE HAZARD AREA IMMEDIATELY.

5. When clear of the hazard area or if it becomes difficult to breathe, remove the hood. The apparatus duration should exceed the time taken to complete a planned escape route.

## 3.4 FACEMASK (SPRINT)



1. Hold a lower harness strap in each hand.



2. Place the chin in the chin-cup and pull the harness over the head. If a neoprene head-harness is fitted, tighten the straps in sequence: bottom, side and then top. **DO NOT OVER-TIGHTEN** as this distorts the face seal, causing leaks.
3. Inhale sharply to activate the first breath mechanism and check that there is an adequate flow of air.
4. If there is no flow of air, use the cylinder valve handwheel to open the valve.
5. **LEAVE THE HAZARD AREA IMMEDIATELY.** When clear of the hazard area, release the head-harness and remove the facemask.
6. After use the apparatus must be cleaned, checked and the cylinder changed, as described in *Section 4 - After Use Cleaning and Testing*.

## 4. AFTER USE CLEANING AND TESTING

### 4.1 CLEANING HOODS (DASH/SPRINT)

1. Disconnect the breathing hose:

#### **Dash only:**



- a) Unclip exhale valve cover and pull the exhale valve from its housing.
- b) Withdraw the elbow retaining U-clip and withdraw the elbow.

#### **Sprint only:**



- a) Unclip exhale valve cover and pull the exhale valve from its housing.
- b) Release the demand valve locking catch, turn the demand valve clockwise and withdraw it from the facemask.

#### **Dash and Sprint:**

2. Wash the exhale valve in a solution of **TriGene™** and warm water.

# ELSA DASH/SPRINT

3. Wipe the surface of the hood, breathing hose and bag using a clean lint-free cloth moistened in a solution of **TriGene™** (Article Numbers 2008247 for 1 litre, or 2008248 for 5 litres) and warm water.

4. Allow the hood and bag to dry naturally away from heat and sunlight.

5. Rinse the exhale valve in clean water and allow to dry thoroughly before re-fitting to its housing.

6. Disinfect the neckseal and inner mask with a **TriGene™** hygienic wipe (Article Number 2004225 for a pack of 20).

7. Use an **Exxene™** de-misting wipe (Article Number 2011081 for a pack of 10) to polish the visor.

8. Apply a film of talcum powder to the neckseal.

9. Attach the breathing hose to the facepiece:

## Dash only:



a) Fit the elbow to the hood, and secure with the U-clip.

b) Fit the exhale valve and clip the valve cover into place.

## Sprint only:

a) Check that the locking catch moves freely without sticking and that the orange O-ring is clean and in good condition.

b) Fit the demand valve to the hood, check that the locking catch clicks into place.

c) Fit the exhale valve and clip the valve cover into place.

## 4.2 CLEANING FACEMASKS

### CAUTION:

**Ensure visor is not scratched or contaminated with oil or grease while cleaning.**

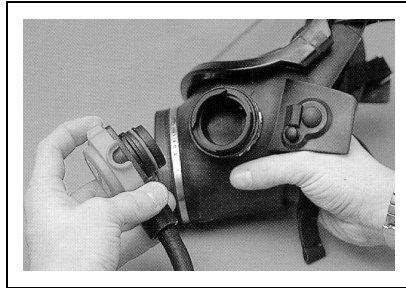

1. Operate the locking catch, turn the demand valve clockwise and withdraw from the facemask.

2. Immerse the facemask in a solution of **TriGene™** and clean warm water.

3. Rinse the facemask in clean water, paying particular attention to the exhale valve.

4. Shake excess moisture from the facemask and allow to dry naturally away from sunlight and direct heat.

5. Disinfect the faceseal and inner mask with a **TriGene™** hygienic wipe.

6. Use an **Exxene™** de-misting wipe to polish the visor.

7. Check the demand valve locking catch moves freely without sticking and that the orange O-ring is clean and in good condition.

8. Fit the demand valve to the facemask. Press the reset button (first breath DV only).

## 4.3 CHANGING CYLINDERS

1. Break the anti-tamper tag and carefully open the bag lid.

2. Unwind the quick-fire cord from the cylinder valve handwheel and detach the quick-fire cord from the handwheel.

3. Open bag fully and check that the cylinder valve is fully closed.

4. Release the cylinder retaining strap and withdraw the cylinder from the bag.



5. Undo the reducer handwheel and remove the reducer from the cylinder valve. Mark the cylinder as empty and return for charging.
6. Check that the reducer and its black O-ring are in good condition and that the O-ring is free from grease.



7. Check that the cylinder contents gauge shows fully charged and screw the reducer into the cylinder valve.



8. Fit the cylinder into the bag and arrange the contents gauge so that it can be seen clearly when the bag is closed. Secure the cylinder with the retaining strap and buckle.

9. Feed the breathing hose into the bag.
10. Arrange the hood in the bag so that it will not foul when pulled from the bag.
11. Check that the quick-fire cord is in good condition.

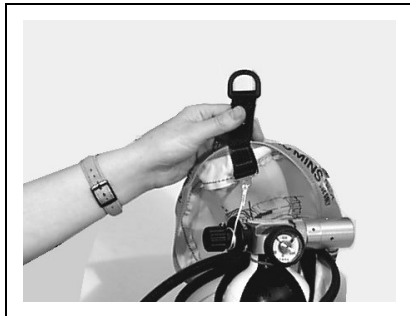

12. Wind the quick fire cord around the cylinder valve handwheel, so that the handwheel turns anti-clockwise when the cord is pulled.
13. Close the bag lid and fit an anti-tamper tag.

### 4.4 BREATHING APPARATUS LOG

Enter details of the results of the preceding tests in the appropriate breathing apparatus log. A breathing apparatus log is available from **Scott Health and Safety Limited** under Article Number 1034745.

### 4.5 STOW APPARATUS

Apparatus should be stored or stowed ready-for-use, away from direct sunlight (which will, through time, degrade the material of the bag).

Apparatus stored in temperatures below +4°C must be thoroughly dry prior to storage and must be kept dry, as ice forming on or in the apparatus may degrade performance.

## 4.6 WORKSHOP REPAIR AND ANNUAL SERVICING

Apparatus must be returned for workshop servicing annually or if a malfunction occurs (see **ELSA Dash** or **ELSA Sprint** Service Manual).

Apparatus stored in a corrosive, dusty, or humid environment may require more frequent servicing. Please contact **Training and Technical Support Services** for advice on servicing or operating the apparatus.

## 5. SCHEDULED MAINTENANCE

### 5.1 GENERAL

It is a mandatory requirement that all escape apparatus shall be checked at monthly intervals.

In addition, apparatus issued to wearers should be checked when issued and daily thereafter. Apparatus deployed to ready-use lockers should be checked daily.

### 5.2 DAILY CHECKS

Daily checks consist of the following:



1. Check that the contents gauge needle is in the green sector, showing that the cylinder is fully charged.
2. Check that the anti-tamper tags are in place and unbroken.
3. Check that access to the bag is unobstructed.

Apparatus that fails any of these checks must be withdrawn from use and returned for workshop service or repair.

### 5.3 MONTHLY CHECKS

#### 5.3.1 Check Apparatus

1. Carefully open the bag, release the quick-fire cord and remove the apparatus from the bag.
2. Check the apparatus for damage or excess wear. Flex the breathing hose and check for splits and crazing (minor crazing is acceptable).

## **Hoods (Dash/Sprint):**

1. Check that there are no splits in the fabric of the hood, visor or neckseal.
2. Check that the breathing hose connection to the hood is secure.
3. Check that the visor is free of blemishes, or creases that might impair visibility or reduce respiratory protection.

## **Facemask (Sprint):**

1. Check that the headharness is fully extended.
2. Check that the facemask is clean and in good condition.
3. Check that the visor is free from blemishes that might impair visibility.
4. Check that the inhale valve flaps in the inner mask lie flat and are in good condition.

## **Breathing Hose Elbow (Dash):**

1. Remove the exhale valve clip-on cover and pull the exhale valve from its housing.
2. Withdraw the elbow retaining U-clip and remove the elbow from the hood.
3. Check that the red O-ring on the elbow is in good condition. Replace if worn, damaged or contaminated with oil or grease.
4. Check that the silencer/filter is not clogged, worn, or damaged. Replace if necessary.
5. Insert the elbow into the hood and fit the retaining U-clip.
6. Check that the exhale valve is in good condition and that the valve flap lies flat on its frame.
7. Push the exhale valve into its housing and fit the clip-on cover.

## **Demand Valve (Sprint):**

1. Disconnect the demand valve from the facepiece.
2. Check that the orange O-ring is clean and in good condition.
3. Check that the locking catch moves freely without sticking.

4. Connect the demand valve to the facepiece. If it is a first breath demand valve, press the reset button and connect to the facepiece.

## **Quick-fire Cord:**

1. Check that the quick-fire cord is in good condition and that the toggle is fitted.
2. Check that the quick-fire cord is attached to the bag lid and wound around the cylinder valve handwheel, so that the cylinder valve handwheel turns anti-clockwise when the cord is pulled.

## **5.3.2 Upon Completion**

1. Check that the cylinder is fully charged.
2. Fit the cylinder into the bag so that the gauge is visible in the bag window and fasten the retaining strap buckle.

## **Hood:**

1. Fold the side and top panels of the hood inwards so that when the hood is folded flat they are between the front and rear panels of the hood.
2. Push the top of the hood into the bag, with the rear hood panel next to the cylinder, until the exhale valve is just below the rim of the bag.
3. Roll the neckseal under the hood so that it will not foul the quick-fire cord.
4. Push the hose fully into the bag alongside the cylinder.

## **Quick-fire Cord:**

1. Fit the toggle of the quick-fire cord to the handwheel and wind the cord around the handle so that it will open the cylinder valve when pulled.
2. Close the bag and fit an anti-tamper tag through the D-rings on the bag and bag lid.
3. Record the results of the checks in the breathing apparatus log.



## **Sabre Breathing Apparatus**

### ***Scott Health and Safety Limited***

*Pimbo Road, West Pimbo  
Skelmersdale, Lancashire,  
WN8 9RA, United Kingdom.*

*Tel: +44 (0) 1695 711711*

*Fax: +44 (0) 1695 711775*