

A COMPLETE GUIDE TO OPERATION, TROUBLESHOOTING AND SERVICE PROCEDURES

The JP Dryer System

An effective solution to the problems of oil, water vapor and contaminants in compressed air systems.

Compressed air, a reliable source of pneumatic power in many applications, is adversely affected by oil, dirt, and water. In a variety of applications from automotive paint booths to concrete plants to general manufacturing facilities, moisture, particulate, and oil in compressed air lines contribute to lower productivity, higher operating costs and increased maintenance.

If your applications depend on a reliable supply of clean, dry air, you may already have explored the options available to you and discovered they are often unreliable, cost-prohibitive, or maintenance intensive.

The DRY AIR SYSTEMS Oil Separator-Filter-Dryer (JP) is a better solution. Not just another air dryer, this ingenious 3-in-1 duplex system typically requires less than 10% of air for regeneration and achieves a -40° F pressure dew point for flow rates of up to 40 CFM. The JP's patent pending modular design allows for expansion to accommodate changes in air system requirements or flow rates exceeding 40 CFM.

What's more, preventative maintenance is straightforward, with accessible valves and two spin on desiccant cartridges. The molecular sieve (desiccant) and filters are housed within the spin on/off cartridges. Typically, these may be serviced within minutes. If required, the valves may be removed and reinstalled without disassembling the unit.

Commonly used in conjunction with large air compressors and systems, the JP dryer system also may be mounted on small air compressors or at point of use such as spray booths or workstations.

JP Dryer System

The JP is a practical, reliable, cost effective solution, insuring quality compressed air—free of oil, contaminants, and water.

- Compact size allows for easy installation and maintenance
- Three-in-One system removes oil, contaminants, and moisture
- Straightforward design provides reliable, long-term operation
- Typically requires less than 10% regeneration air while others draw up to 20%

TABLE OF CONTENTS

Introduction.	3
Chapter1: Installation.	4
• JP Installation and Service Instructions	
• Basic Mounting Guidelines	
• Mounting JP Base Assembly	
• Connecting Air Lines	
• Installing Desiccant Cartridges &	
• Mufflers	
• Micro Logic Timer (MLT) Electrical	
• Connection	
• Start-up/Check	
• JP Operation/Cycle	
• Schematic Drawings	
• Service Parts Schematic	
Chapter2: JP Lists	7
• JP Dryer Parts List	
• Service Parts Identification	
• Major Service Kit	
• Minor Service Kit	
Chapter 3: Trouble-shooting	8
• JP Air Dryer Operation/Cycle	
• Problems, Causes, Remedies	
Chapter 4: Service Procedures	10
• JP Air Drying System	
Warranty	13

JP INSTALLATION AND SERVICE INSTRUCTIONS

WARNING: BEFORE PROCEEDING WITH INSTALLATION READ AND OBSERVE THE FOLLOWING SAFETY PRECAUTIONS:

1. Read entire instruction sheet before beginning installation or servicing of JP.
2. Never connect or disconnect a pipe/line containing air pressure or remove a component, fitting or pipe plug unless you are certain all air pressure has been relieved.
3. Always wear proper eye protection when installing or servicing JP.
4. Never look directly into ports of JP.
5. Never exceed recommended working air pressure of 175 psig.
6. Never attempt to install or service JP until you read and understand all recommended procedures.
7. Use only proper tools and observe all precautions pertaining to the use of those tools.

BASIC MOUNTING GUIDELINES

1. The JP must be mounted with the exhaust ports positioned downward (ref. Figure 1, Pg. 5).
2. Power source: 110-120 Volt AC (grounded) surge protected (recommended) electric receptacle required for operation of JP.
3. Mount JP down stream of air compressor reservoir (ref. Figure 1, Pg 5).
4. The JP should be mounted in a location with sufficient space around it to facilitate service and to provide visual access for periodic inspection. Allow at least a two (2.00) -inch clearance above desiccant cartridges for service (ref. Figure 2, Pg. 5).
5. Consider installing a series of lines and shut-off valves in conjunction with installation of the JP to provide a by-pass system of the JP. Doing so will provide ability to maintain operation of air system when servicing JP.

MOUNTING JP BASE ASSEMBLY

1. After determining proper location for JP as instructed in “Basic Mounting Guidelines” section, refer to Figure 2, Pg. 5 for mounting reference dimensions.

NOTE: The JP is available with either standard wall or optional universal mount bracket as shown

in Figure 2. Either type bracket may be inverted from position shown in Figure 2, Pg. 7 to facilitate mounting.

2. Mount base assembly at chosen location prior to installing desiccant cartridges. Make sure there will be a minimum two (2.00) -inch clearance above desiccant cartridges for future service.
3. Refer to Figure 2, Pg 5 for mounting hole locations, and attach JP to mounting location with a minimum of two (2) 3/8" bolts.

CONNECTING AIR LINES

1. Connect high-pressure airline (175 psig max.) to JP inlet port (ref. Figure 1, Pg 5).
2. Connect JP outlet port to system airline (ref. Figure 1, Pg 5).

NOTE: Use thread sealant on airline fittings to prevent air leaks.

INSTALLING DESICCANT CARTRIDGES & MUFFLERS

1. After base assembly is mounted, install both desiccant cartridges to base assembly as follows:
 - a. Install o-ring into groove of each center thread adaptor in base assembly.
 - b. Lubricate both o-rings and threads.
 - c. Lubricate contact surface of flat gasket located in cartridge plate.
 - d. Start cartridge onto thread adaptor being careful not to cross thread. Turn cartridge clockwise until flat gasket contacts casting surface. After gasket contact, turn cartridge only 1/2 to 3/4 additional turns.

NOTE: Do not over-tighten cartridge or future removal will be extremely difficult.

2. Install muffler into each exhaust port of JP.

MICRO LOGIC TIMER (MLT) ELECTRICAL CONNECTION

1. Plug-in MLT power cord to 110-120 Volt AC grounded receptacle (surge protected recommended).

NOTE: The MLT device is polarity sensitive. MLT will not operate if power (+) and neutral (-) leads are switched.

START-UP/CHECK

1. Ensure that all airline fittings are properly connected.
2. Pressurize system.
3. Check airline fittings for leaks and repair leaks.
4. Observe operation of JP for proper function as described in JP OPERATION/CYCLE section. (listed below)

JP OPERATION/CYCLE

1. The Micro Logic Timer (MLT) controls drying and regeneration cycles of the JP by energizing and de-energizing the "air control valve" of JP at 2-minute intervals. An indicator light on MLT will be on during energized cycle and off during the de-energized cycle.
2. The JP's "air control valve" controls airflow direction through the JP. During operation, one desiccant cartridge is drying air and the other cartridge is being regenerated.
3. During operation there will be a light flow of air from ONE exhaust port (muffler) of JP. This is normal, regeneration; airflow and the airflow will alternate every 2 minutes from one exhaust port to the other in

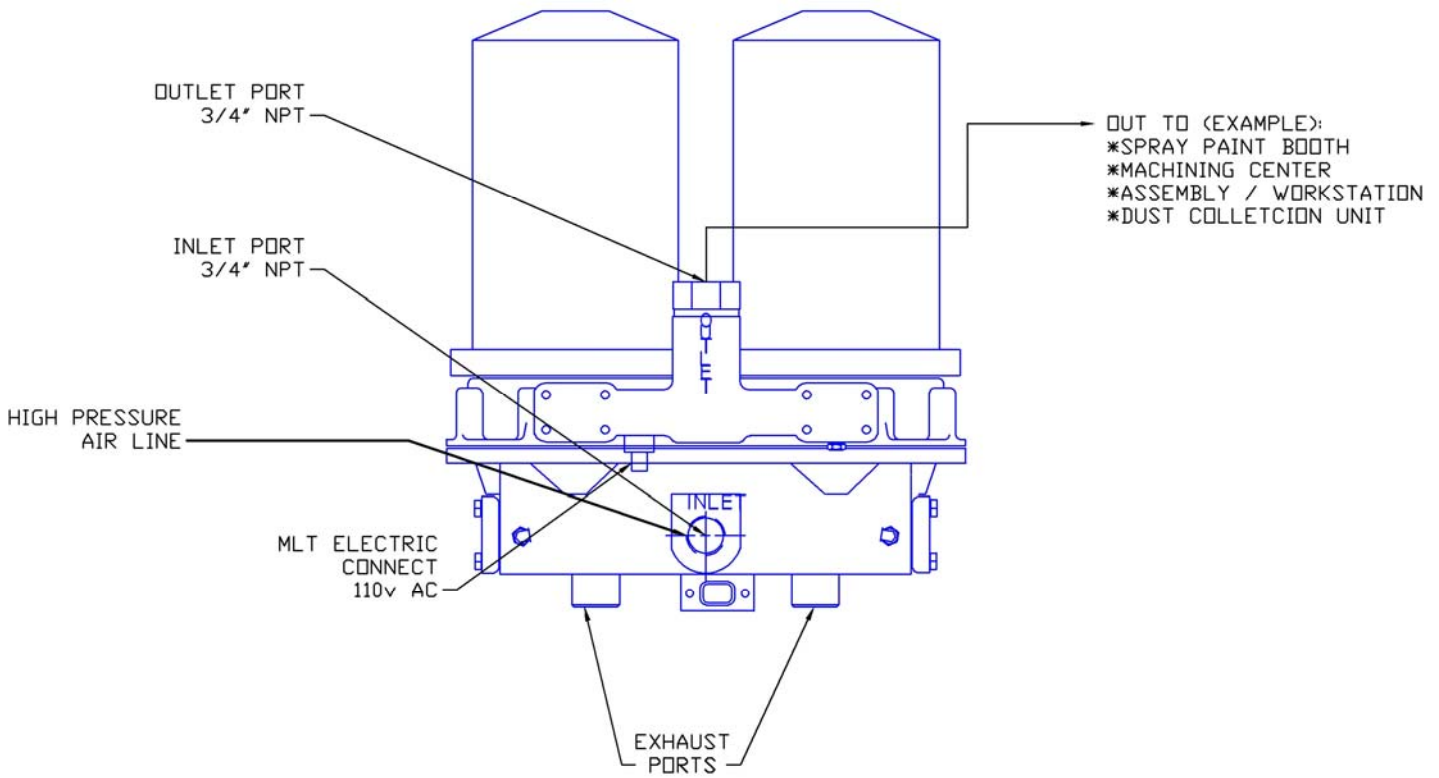

Figure 1: Air Connection Schematic

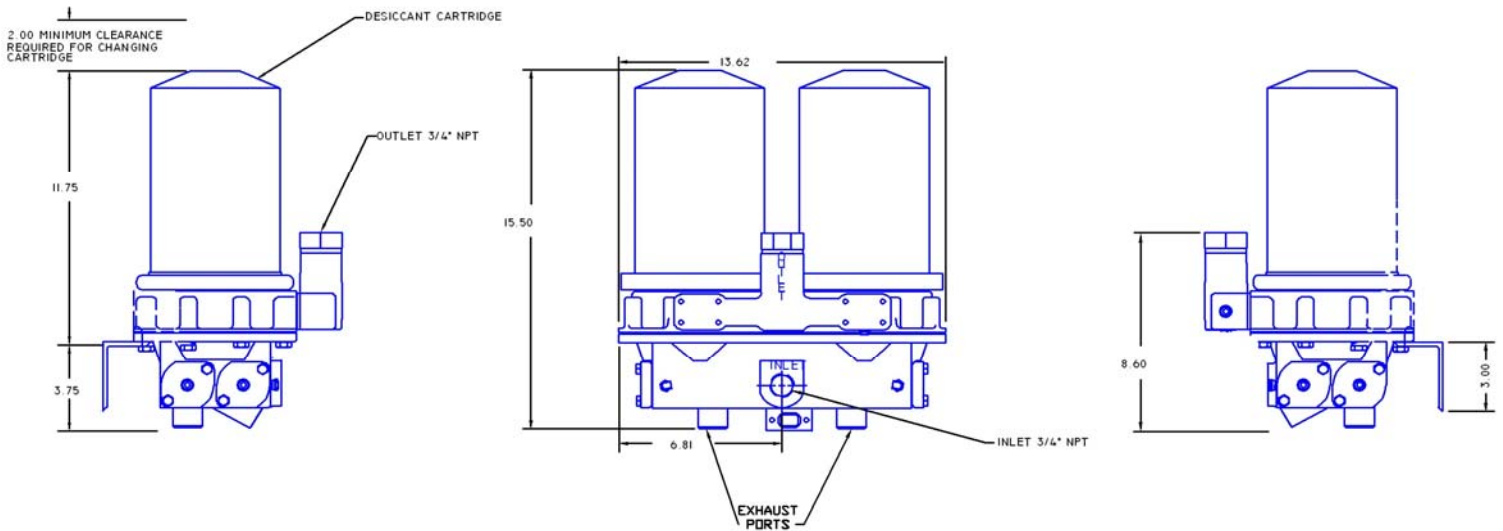
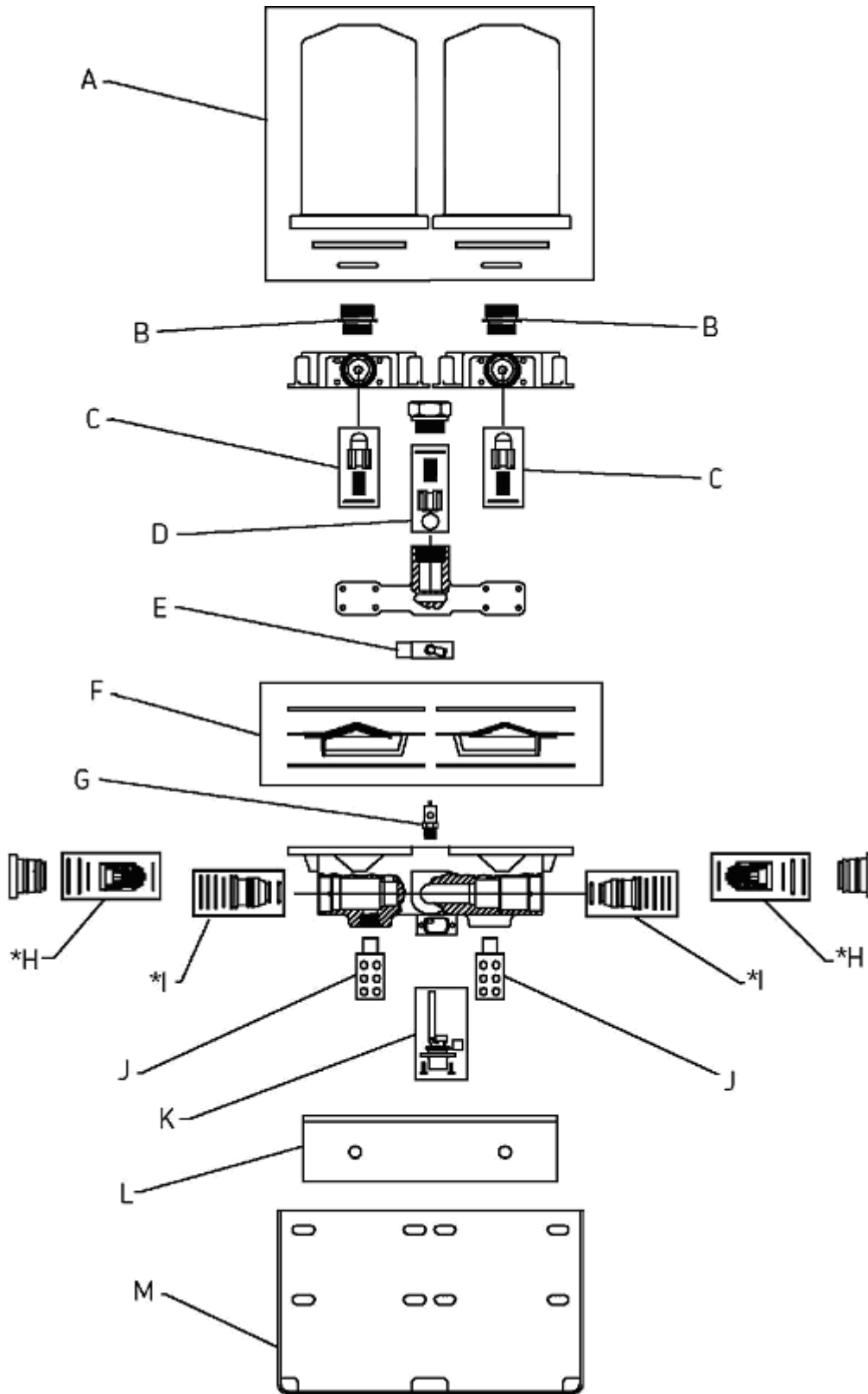

Figure 2: JP Unit Dimensions

SERVICE PARTS SCHEMATIC



*H & I – 2 each in service kits 619700 and 619702

JP DRYER PARTS LIST

JP Air Drying System – Complete Models		Air Flow Capacity
640100	W/Universal Mounting Bracket	Up to 40 SCFM
640200	W/Wall Mounting Bracket	
640300	W/O mounting bracket or W/O Oil Separators	
640400	W/Wall Mounting Bracket Duplex System	*40 – 80 SCFM

* Contact customer Service @ 1-314-344-1114 for applications greater than 80 CFM Service Parts Identification

Service Parts Identification

BOLD SKU SUGGEST SERVICE STOCK

A	* 619704	Desiccant Cartridge Kit
B	619765	Cartridge Stud
C	619715	Regeneration Valve Kit Note: Two valves per dryer, one on either side.
D	Use * 619702	Outlet Check Valve - Not sold separately
E	619755	Air Control Valve
F	619760	Oil Separator Kit
G	619740	Safety Valve (200 PSI)
H	Use * 619702	Purge Valve - Not sold separately
I	Use * 619702	Inlet Check Valve - Not sold separately
J	619770	Muffler
K	619750	120 Volt AC Heater Kit (Optional)
L	619990	Wall Mounting Bracket
M	619995	Universal Mounting Bracket

Major Service Kit

A	619700	2 - Desiccant Cartridges
D		1 - Outlet Check Valve
H		2 - Purge Valves
I		2 - Inlet Check Valves

* Supplied also in 619700

TROUBLE-SHOOTING

JP AIR DRYER SYSTEM

JP AIR DRYER OPERATION/CYCLE (All Models)

1. The Micro Logic Timer (MLT) controls drying and regeneration cycles MALFUNCTIONING of the JP Air Drying System by energizing and de-energizing the Air SYSTEM PRESSURE SETTING Control Valve at two (2) minute intervals. An indicator light on MLT will be “on” during energized cycle and “off” during the de-energized cycle.
2. The JP’s Air Control Valve controls air flow direction through the JP during operation. During operation one JP cartridge is drying air while the other cartridge is being regenerated.
3. During operation there will be a light flow of air from ONE exhaust port (muffler) of JP. This is normal regeneration airflow. The airflow will alternate (every 2-minutes) from one exhaust port (muffler) to the other in conjunction with the MLT cycles. When the JP cycle alternates there will be a momentary burst of air from one of the JP exhaust ports (muffler). This airburst is normal and will occur each time JP cycle alternates.

PROBLEM: HEAVY AIR FLOW FROM ONE OR BOTH OF JP EXHAUST PORTS (MUFFLERS)

NOTE: ALTERNATING “LIGHT” AIR FLOW FROM EXHAUST PORT (MUFFLER) IS NORMAL AS THIS REPRESENTS THE REGENERATION CYCLE

POSSIBLE CAUSE	REMEDY
WORN PURGE VALVE OR DIRT/FOREIGN MATERIAL IS STUCK IN THE PURGE VALVE	CLEAN CAVITIES AND REPLACE PURGE VALVE ASSEMBLY ITEM “H” (REF. Pg. 6) SERVICE KIT #619702
WORN INLET CHECK VALVE	CLEAN CAVITY AND REPLACE VALVE ASSEMBLY ITEM “I” (REF. PG. 6) SERVICE KIT #619702

PROBLEM: SAFETY VALVE OPENS

POSSIBLE CAUSE	REMEDY
SAFETY VALVE MALFUNCTIONING REPLACE SAFETY VALVE #619740-200 PSI	ITEM “G” (REF. Pg 6) SERVICE KIT #619740
SYSTEM PRESSURE SETTING EXCEEDS SAFTEY VALVE SETTING (200 PSI)	REDUCE SYSTEM OPERATING AIR PRESSURE

PROBLEM: WATER IN AIR SYSTEM

POSSIBLE CAUSE

REMEDY

DESICCANT IS CONTAMINATED	REPLACE DESICCANT CARTRIDGES ITEM "A" (REF. Pg. 6) SERVICE KIT #619700 OR #619704
MICRO LOGIC TIMER (MLT) MALFUNCTIONING	CONTACT DRY AIR SYSTEMS CUSTOMER SERVICE (1-314-344-1114) OR LOCAL DISTRIBUTOR REPRESENTATIVE
AIR CONTROL VALVE MALFUNCTION	REPLACE AIR CONTROL VALVE ITEM "E" (REF. Pg. 6) SERVICE KIT #619755
MALFUNCTIONING REGENERATION VALVE(S)	REPLACE REGENERATION VALVE(S) ITEM "C" (REF. Pg. 6) SERVICE KIT #619715
AIR LINE (TUBING) CONNECTING AIR CONTROL VALVE AND VALVE HOUSING AND/OR MANIFOLD DAMAGED OR MISSING	REPAIR/REPLACE AIRLINE(S) (TUBING) CHECK FOR LEAKS AT FITTING THREADS
EXHAUST PORTS IN PURGE VALVE AND VALVE HOUSING NOT ALIGNED	ALIGN EXHAUST PORTS IN PURGE VALVE AND VALVE HOUSING
COMPRESSED AIR USAGE EXCEEDS DRYING CAPACITY OF JP	CONTACT DRY AIR SYSTEMS CUSTOMER SERVICE (1-314-344-1114)
WORN PURGE VALVE	REPLACE PURGE VALVE ASSEMBLY ITEM "H" (REF. Pg. 6) SERVICE KIT #619700 OR #619702

PROBLEM: JP'S CYCLES WILL NOT ALTERNATE EVERY TWO MINUTES POSSIBLE CAUSE REMEDY

POSSIBLE CAUSE

REMEDY

MICRO LOGIC TIMER (MLT) MALFUNCTIONING	CONTACT DRY AIR SYSTEMS CUSTOMER SERVICE (314-344-1114)
AIR CONTROL VALVE MALFUNCTION	REPLACE AIR CONTROL VALVE #619755 ITEM "E" (REF. Pg. 6) SERVICE KIT #619755
AIR LINE (TUBING) CONNECTING AIR CONTROL VALVE AND VALVE HOUSING AND/OR MANIFOLD DAMAGED OR MISSING	REPAIR/REPLACE AIRLINE(S) (TUBING)

PROBLEM: JP'S INADEQUATE SYSTEM AIR VOLUME AFTER JP AIR DRYER

POSSIBLE PROBLEM

REMEDY

AIR FLOW RESTRICTION (NEW INSTALLATION)	CONTACT DRY AIR SYSTEMS CUSTOMER SERVICE (1-314-344-1114)
DESICCANT CARTRIDGES/ OIL SEPARATORS RESTRICTED	REPLACE DESICCANT CARTRIDGES ITEM "A" (REF. Pg. 6) SERVICE KIT #619700 OR #619704 REPLACE OIL SEPARATORS ITEM "F" (REF. Pg. 6) SERVICE KIT #619760

SERVICE PROCEDURES

JP AIR DRYING SYSTEM

(Items A, C, D, E, F, H, I, K)

WARNING: BEFORE SERVICING JP DRYING SYSTEM, READ AND FOLLOW SAFETY PRECAUTIONS FOUND ON PAGE 3. REVIEW DESCRIPTION OF JP AIR DRYER OPERATION/CYCLE, LOCATED ON Pg. 8.

Item “A” Desiccant Cartridges - #619704 Cartridges only or Major Service Kit #619700

1. Relieve all system air pressure.
2. Using a strap wrench, turn the desiccant cartridge counterclockwise and remove it. Discard.
3. Remove and discard O-ring from adapter plate stud.
4. Clean top surface of adapter plate and threaded stud.
NOTE: If there is excessive oil present, compressor and/or oil separator (Kit #619760) require servicing.
5. Using grease supplied, apply a light coating on o-ring. Install o-ring on stud.
6. Apply a generous coat of grease on the new desiccant cartridge gasket surface.
7. Thread new cartridge onto stud turning clockwise. When gasket contacts adapter plate, tighten cartridge 1/2 to 3/4 turns.
DO NOT OVER-TIGHTEN!

Item “C” Regeneration Valves - #619715

Note: A light flow of air from exhaust port (muffler) during operation is normal regeneration airflow.

1. Relieve all system air pressure.
2. Disconnect airline from outlet port of air dryer.
3. Remove eight (8) socket head bolts fastening manifold to adaptor castings.
4. Remove manifold from adaptor castings.
5. Remove and discard o-rings, springs and regeneration valves.
6. Clean valve cavities in adaptor castings.
7. Position new valve spindles into cavities with spring pockets out.
8. Position springs into valves.
9. Lubricate new o-rings and install onto manifold bosses.
10. Position manifold onto adaptor castings ensuring O-rings are properly positioned in bores.
11. Install eight (8) socket head bolts and tighten to 50-60 in. lbs.
12. Reconnect airline to outlet port.

Item “D” Outlet Check Valve #619700 Major Service Kits or #619702 Minor Service Kit

1. Relieve all system air pressure.
2. Disconnect airline from dryer outlet port.
3. Remove check valve nut.
4. Remove and discard o-ring, spring, spindle, and ball.
5. Clean nut and check valve cavity thoroughly.
NOTE: If there is excessive oil in the cavity, oil separator and desiccant cartridges require servicing.
6. Install new ball into cavity.
7. Install spindle, with spring pocket out, into cavity.
8. Place spring into spring pocket of spindle.
9. Apply a light coating of grease onto o-ring and place onto check valve nut.
10. Apply light coating of grease to nut threads. Install nut and tighten to 60 ft. lbs.
11. Re-connect airline to outlet port.

Item “E” Air Control Valve - #619755

Note: Disconnect power from MLT.

- With system pressurized, turn the brass screw located on air valve to the right -clockwise (screw slot will be in horizontal position). If exhaust air burst does not occur, replace valve. If exhaust air burst does occur, turn screw back to original position counter-clockwise (screw slot must be in vertical position for normal operation).
 - Failure of dryer to exhaust could also be due to malfunctioning MLT or purge valve. Refer to pages 10 and 16 for service of these items.
1. Relieve all system air pressure.
 2. Un-plug electrical connector from MLT Valve.
 3. Remove three (3) airlines connected to fittings in air valve.
 4. Remove plastic retaining nut holding MLT assembly to valve stem and remove MLT assembly from valve. Set aside nut and MLT for re-assembly later.
 5. Remove three (3) screws holding valve to manifold. Remove valve and discard.
 6. Install three (3) new push connect airline fittings to open ports of new valve.
 7. Attach valve to manifold with three (3) screws.
 8. Tighten screws to 15-20 in. lb.
 9. Re-connect airline from manifold to front port of air valve.
 10. Re-connect two remaining airlines to back ports of valve.
 11. Re-assemble MLT assembly to valve stem and secure with retaining nut (finger tight).
 12. Reconnect electrical power.

Item “F” Oil Separators - #619760

1. Relieve all system air pressure.
2. Disconnect heater lead wire from air dryer (if equipped)
3. Disconnect airline from dryer inlet port.
4. Remove two (2) desiccant cartridges (strap wrench may be necessary)
5. Remove (4) 3/8” Allen head bolts, located at top of adaptor casting, attaching adaptor castings to bottom valve housing.
6. Remove (12) 3/8” hex head bolts attaching bottom valve housing to adaptor castings.
7. Remove bottom valve housing assembly.
8. Remove two (2) oil separators and (4) gaskets from valve housing and discard.
9. Clean valve housing sump and inside of two (2) adaptor castings of all oil and contaminates.
10. Place one new gasket on each valve housing bolt flange.
11. Place new oil separators on top of first gaskets on valve housing (use two bolts to align components).
12. Place second new gasket on top of oil separators.
13. Reinstall valve housing/oil separator to adaptor castings.
14. Torque (16) bolts to 25-30 ft. Ibs.
15. Re-install two (2) desiccant cartridges.
NOTE: It is recommended to also install major service kit #619700 when excessive oil and contamination is present
16. Re-connect airline to air dryer inlet port.
17. Re-connect heater wire (if equipped).

Item “H” Purge Valves - #619700 Major Service Kit or #619702 Minor Service kit

Note: A light flow of air from ONE exhaust port (muffler) during operation is normal, regeneration air flow

1. Relieve all system air pressure.
2. Remove two bolts that attach the purge valve retainer. Remove the retainer.
3. Remove the purge valve assembly and O-ring from the purge cavity and discard.
4. Clean the cavity thoroughly.
5. Remove the three (3) O-rings from retainer and discard.
6. Using lubricant supplied, lightly grease all three new O-rings.
7. Install on the retainer the two (2) larger O-rings then install the third (smaller) O-ring.
8. Apply a light coating of grease around the O-ring seat on valve assembly. Install the thin o-ring on the purge valve seat.
9. Insert valve assembly into cavity. Insure that hole in valve sleeves aligns over housing exhaust port (muffler). Use care not to dislodge the O-ring from its seat.

WARNING:

If the JP purge valve port does not align with housing exhaust port, JP will not exhaust!

10. Install retainer to housing.
11. Apply a light coating of grease on the threads of the two retainer bolts.
12. Install two retainer bolts. Tighten to 10-15 ft. lb.

Item “I” Inlet Check Valves - #619700 Major Service Kit or #619702 Minor Service kit

Note: A light flow of air from ONE exhaust port (muffler) during operation is normal, regeneration air flow.

1. Relieve all system air pressure.
2. Remove the two bolts that attach the inlet check valve retainer. Remove the retainer.
3. Remove the inlet check valve spindle from the inlet cavity and discard.
4. Clean the cavity thoroughly.
5. Remove the two (2) O-rings from retainer and discard.
6. Install two (2) large O-rings on the retainer.
7. Lubricate O-rings on check valve- spindle and install the spindle (small end first) into the inlet cavity. Make sure spindle is completely engaged in cavity and slides freely.
8. Lubricate O-rings on seal retainer and re-install retainer.
9. Apply a light coating of grease on the threads of the two retainer bolts.
10. Install two retainer bolts. Tighten to 10-15 ft. lb.

Item “K” Heater Assembly (if equipped) - #619750

Note: Heater option to prevent inlet and purge valve freezing when JP is mounted where ambient air temperatures may fall below 32° F (0° C).

1. Disconnect heater lead wire.
2. Remove two screws attaching heater connector to casting.
3. Remove heater/thermostat assembly and discard.
4. Thoroughly clean entire heater/thermostat area.
5. Slide O-ring over heater and thermostat into position around connector flange.
6. Apply a light coating of anti-seize to the heater element and thermostat cavity.
7. Insert heater element into hole and twist slightly to spread anti-seize.
8. Place thermostat into position in cavity and ensure thermostat sits flat in cavity.
9. Place foam cube on top of thermostat and bring heater connector into position over cavity.
10. Secure heater connector using the (2) 8-32 x1/2” screws.
11. Reconnect heater.

WARNING: Proper selection of the products listed for sale in this catalog is essential to minimize the risk of any seal, bearing or other product failure. Such failures can result in property damage or severe personal injury to operators of machinery, vehicles or to others. You must carefully evaluate the particular application on or into which you intend to install the products. Products in this catalog require installation by an experienced professional mechanic or qualified maintenance professional.

The product properties and operating parameters described in this catalogue are based upon tests conducted by DRY AIR SYSTEMS or reported by others. DRY AIR SYSTEMS does not assume any responsibility for errors in the data published in this catalog. The life and performance of the products ultimately depend on a number of factors. These include, for example, seal or bearing design, selection of materials for their different properties, handling and installation, shaft surface or bore conditions, operating conditions, and the quantity, quality and chemistry of lubricants. Severe environments can adversely affect product life or performance. For help in realizing longer seal or bearing life, and optimal performance for your specific application, contact DRY AIR SYSTEMS at 1-314-344-1114.

LIMITED WARRANTY

DRY AIR SYSTEMS as the seller of the products contained in this catalog warrants to the first user/purchaser that the products sold by it, when properly installed, will be free from defects in material and workmanship. DRY AIR SYSTEMS's sole obligation and liability for any defect found to exist in a product sold by DRY AIR SYSTEMS contrary to this warranty, and purchaser's sole and exclusive remedy for such defect, shall be limited to: (A) DRY AIR SYSTEMS furnishing without additional charge to purchaser, including transportation, a replacement for any of the products sold by DRY AIR SYSTEMS which are found by DRY AIR SYSTEMS to be defective contrary to this limited warranty, and (B) in the case of products which cannot be re-paired or replaced by DRY AIR SYSTEMS, DRY AIR SYSTEMS shall credit or refund purchaser the purchase price paid therefore; provided, that DRY AIR SYSTEMS is advised in writing of such product non-conformance within thirty (30) days of the date of discovery thereof, and that the non-conforming product is returned f.o.b. to DRY AIR SYSTEMS's designated warehouse promptly thereafter, but in any case not later than twelve (12) months from the date of original shipment of the product to purchaser by DRY AIR SYSTEMS. In no event shall DRY AIR SYSTEMS be obligated under this warranty or otherwise in any way whatsoever for normal wear and tear, or for any products sold by DRY AIR SYSTEMS which, after delivery by DRY AIR SYSTEMS and in DRY AIR SYSTEMS's sole determination, have been subjected to accident, abuse, misapplication, improper or faulty repair or installation, improper or faulty maintenance or lubrication, any alteration or neglect, excessive loading or other excessive operating conditions, or for defects caused by or resulting from purchaser's specifications or designs or otherwise caused by purchaser. TO THE FURTHEST EXTENT PERMITTED UNDER APPLICABLE LAW, DRY AIR SYSTEMS DISCLAIMS LIABILITY, IN TORT OR CONTRACT, IN NEGLIGENCE, STRICT LIABILITY, OR OTHERWISE, FOR ANY OTHER REMEDY OR DAMAGE, WHETHER DIRECT OR INDIRECT, INCIDENTAL OR CONSEQUENTIAL WITH RESPECT TO ITS PERFORMANCE HEREUNDER, INCLUDING WITHOUT LIMITATION WITH RESPECT TO THE PRODUCTS SOLD OR PROVIDED HEREUNDER BY DRY AIR SYSTEMS, AND ITS PROVISION OF ANY RELATED SERVICES. THIS EXPRESS WARRANTY IS TO THE EXCLUSION OF ALL OTHER WARRANTIES, EXPRESS OR IMPLIED, INCLUDING WARRANTIES OF MERCHANTABILITY OR FITNESS FOR A PARTICULAR PURPOSE. COSTS INCURRED FOR ROUTINE MAINTENANCE ARE NOT COVERED BY THIS WARRANTY. Without limiting the generality of the foregoing disclaimer, DRY AIR SYSTEMS specifically disclaims liability to purchaser for any loss, cost, or damage incurred as a result of equipment downtime, or loss of use or availability of worksite, lost revenues or lost profits, or losses or liability arising, regardless of whether DRY AIR SYSTEMS is on notice of the possibility of such damage or loss and did or could have anticipated same. No other person has been authorized by DRY AIR SYSTEMS to undertake or make on behalf of DRY AIR SYSTEMS any further representation, warranty or guarantee in addition to or contrary to DRY AIR SYSTEMS's warranty made herein or contrary to the limitations and disclaimers provided herein. The exclusive remedies provided in this limited warranty shall not be deemed to have failed of their essential purpose so long as DRY AIR SYSTEMS is willing and able to perform to the extent and in the manner prescribed in this warranty.

INFORMATION: Inquiries can be directed to:

DRY AIR SYSTEMS Customer Service Department,
2655 Metro Boulevard
Maryland Heights, MO 63043

Or call 314-344-1114

Approved returns must be shipped freight prepaid and arrive right of Dry Air Systems

LIMITATION ON RETURNS: Any product that is not in conformance with purchaser's description given in its order is returnable for credit or replacement by Dry Air Systems, provided that Dry Air Systems is advised in writing by purchaser of such non-conformance within 30 days after the product's delivery to purchaser by Dry Air Systems, and only after written authorization therefore is given by Dry Air Systems. Approved returns must be shipped freight prepaid and arrive in good, saleable condition to qualify for credit or replacement.

NOTES: