



Heatmaker H, HP and HW *Operating, Installation* *& Maintenance Instructions*

THIS UNIT MUST BE INSTALLED IN ACCORDANCE WITH STATE AND LOCAL CODES BY A QUALIFIED INSTALLER.

To the Installer: After installation these instructions must be given to the homeowner or left on or near the boiler.

To the Homeowner: This booklet contains important information that will help you in maintaining and operating this boiler. Please retain it for future reference.



HW-M2 Series

HW-M2-130
HW-M2-100
HW-M2-60

Integrated Hydronic Heating
and Domestic Hot Water Appliance
For Natural or Propane Gas.

H-M2 Series

H-M2-130*
H-M2-100
H-M2-60

Hydronic Heating Only
For Natural or Propane Gas.

HP-M2 Series

HP-M2-130*
HP-M2-100
HP-M2-60

Hydronic Heating Only
For Natural or Propane Gas
(Wall Hung).

* Field conversion only.

INSTALLATION

Introduction 2
 Schematic Diagram HW - M2 - Series 2
 Schematic Diagram H(P) - M2 - Series 3
 Unpacking 3
 Venting Options 4
 Horizontal / Vertical Venting..... 6
 Direct Venting & Air Source..... 8
 Gas & Domestic Water Piping 9
 Hydronic Heat Piping 10
 Electrical Connections 13
 HP Installation 14
 Modular Home Installation 16
 Check, Test & Start Up 17
 Maintenance 18

SERVICE

Cleaning Combustion Chamber Coil 19
 Boiler Components Descriptions 19-21
 Domestic Water Coil Replacement 21
 Tank Replacement 21
 Delayed Ignition 22
 Noisy Operation 22
 High Gas Consumption 23
 Insufficient Hot Water 23
 Short Cycling 23
 Cross Contamination 24
 Lock Outs 24
 Sequence of Operation 25
 Trouble Shooting Flow Charts 26-32
 Parts List & Order Information 33
 Electrical Diagrams 36-37

INTRODUCTION

HW-SERIES

Model HW(D)-M2-130, HW(D)-M2-100, HW(D)-M2-60

H(P)-SERIES

Model H-M2-130, H-M2-100, H-M2-60.

The HEATMAKER MARK II boiler is a low pressure, hot water boiler that is available in two (2) design configurations. The "HW" series provides domestic hot water as well as hydronic space heating. It includes an insulated storage tank through which boiler water is circulated. A heat exchanger within the tank transfers heat from the boiler to the domestic hot water. The "H" and "HP" series boilers are designed to provide hot water for space heating, and can be plumbed to an indirect water heater to supply domestic hot water.

By replacing the air and the gas orifices, the basic Heatmaker boiler has the flexibility to operate on either natural or LP gas and may be fired at 60,000, 100,000 or 130,000 BTU/HR input. The Heatmaker can be direct vented by utilizing an optional concentric vent system that will provide outside air for combustion. H(W)(P)-60,100 & 130 appliances may also be vented with 3" or 4" diameter stainless steel horizontal / vertical venting as described on page 6. The maximum length shall not exceed 50 equivalent feet of 3" diameter or 100 equivalent feet of 4" diameter. H(W)(P)-M2-130 appliances may also be connected to a lined internal chimney.

The Heatmaker features a forced draft, pre-mixed combustion system. All air for combustion is supplied with the gas to the burner (flameholder). Both the intake air and the gas are metered through separate orifices before entering the combustion air blower. The blower forces the air/fuel mixture through the flameholder and into the combustion chamber. The mixture is ignited from the hot surface igniter and burns. Hot gases are forced out between the passes of the heat exchanger into the flue collector. Flue gases are discharged into the outside atmosphere through the vent terminal, a chimney, horizontal or vertical alternate vent.

Model H(W)-M2-60 & H(W)-M2-100 UNITS MUST NOT BE CHIMNEY CONNECTED.

INSTALLATIONS WITH WATER CONTAINING 10 GRAINS OF HARDNESS OR HIGHER, MUST BE INSTALLED WITH APPROPRIATE WATER TREATMENT.

Figure 1. HW-M2.

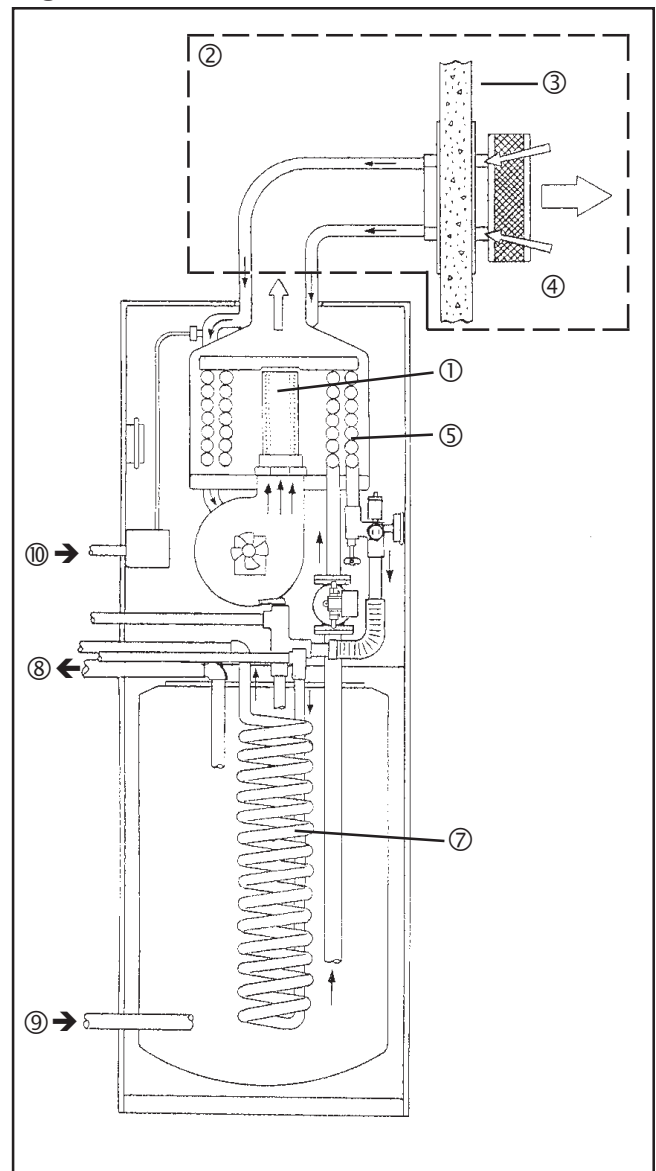

TO THE INSTALLER : BEFORE YOU BEGIN

The Heatmaker is uniquely different from any heating boiler you have installed in the past. It is important for you to take a few minutes to review the contents of the Installation and Operating section of this manual before you begin installation. This will avoid making mistakes and causing confusion when installing and operating the unit.

1. Gas Burner*
 2. Sealed Combustion* w/ P/N 2400-236 or 2400-238
 3. Outside Vent Wall*
 4. Outside Air For Combustion*
 5. Copper Coil Heat Exchanger*
 6. Thermostatic Union (H-M2)
 7. Domestic Hot Water Coil (HW(D)-M2)*
 8. Heating System Water Outlet
 9. Heating System Water Return
 10. Gas Supply
- *See Figure 1

Figure 2. H-M2.

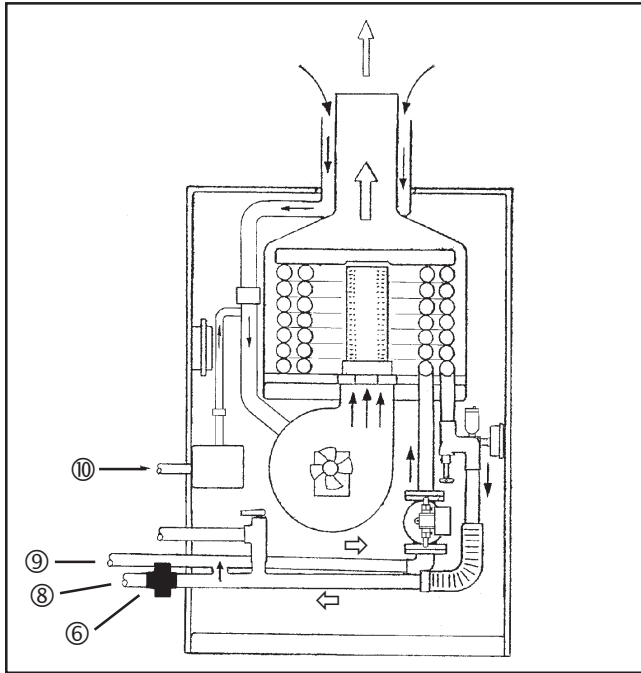

CODES & STANDARDS

All installations must be made in accordance with:

- 1). the National Fuel Gas Code, ANSI Z223.1 - latest edition or
- 2). CAN/CGA - B149 "Installation Codes for Gas Burning Appliances and Equipment"

or with the requirements of the local utility or other authorities having jurisdiction. Such applicable requirements take precedence over the general instructions contained herein. All electrical wiring is to be done in accordance with 1). the National Electrical Code ANSI/NFPA70-latest edition or 2). the CSA standard C22.1 "Canadian Electrical Code - Part 1" and local codes.

All vent installations must be made in accordance with:

- 1). Part 7, Venting of Equipment of the National Fuel Gas Code, ANSI 223.1- latest edition, or applicable provisions of the local building codes or
- 2). CAN/CGA - B149

When required by the jurisdiction authority, the installations must conform to the American Society of Mechanical Engineers' Safety Code for Controls and Safety Devices for Automatically fired Boilers, No. CSD-1.

UNPACKING THE HEATMAKER

- a. Remove all packing and tie down materials.
- b. On HW models, remove three (3) shipping bolts from underside of base.
- c. Make immediate claims (to carrier) if unit is damaged.

LOCATING THE HEATMAKER

The Heatmaker design is certified by the AGA and CGA for installation on combustible flooring, in alcoves, basements, closets, or utility rooms. It must not be installed on carpeting. IF INSTALLED IN A FINISHED AREA, PROVISION SHOULD BE MADE FOR DRAINAGE OF ANY ACCIDENTAL SPILLAGE OR LEAKAGE.

The location for the unit should be chosen with regard to venting dimensions, convenient access to piping, ventilation of operating components and accessibility for service and cleaning.

The boiler shall be installed so that the gas ignition system components are protected from water (dripping, spraying, rain, etc.) during appliance operation or service (circulator replacement, control replacement, etc.).

CLEARANCES

The following dimensions and criteria should be followed when choosing the location for the unit:

| | B. | | |
|-----------------------|---------|-----|-----|
| | AGA/CGA | AGA | CGA |
| Left Side | 1" | 6" | 24" |
| Right Side (controls) | 1" | 12" | 24" |
| Top | 1" | 14" | 16" |
| Back | 1" | 9" | 12" |
| Front | 1" | 24" | 24" |

| | | |
|-------------------|----|----|
| Vent: Direct Vent | 0" | 0" |
| Chimney Connect | 6" | 6" |
| Alternate | 3" | 3" |

- A. Minimum clearance from combustible construction to meet AGA/CGA requirements.
- B. Recommended clearance for accessibility and venting.

LOCATING UNIT WITH RESPECT TO VENTILATION

While the Heatmaker, when direct vented, requires no interior air for combustion, adequate airflow around the unit and to the enclosed room must be provided for proper cooling of electrical components.

CHIMNEY VENTING (USA Only)

Model H(W)-M2-130 is a category I boiler and may be vented in chimneys subject to the following requirements:

Model H(W)-M2-60 and H(W)-M2-100 **MUST NOT BE CHIMNEY OR B-VENT CONNECTED.**

A Chimney must be internally lined or "B" vent type. External or unlined chimneys may serve as a chase for utilization of stainless steel alternative venting providing no other equipment is vented into it, or the chimney may have an approved liner installed into the flue.

B. Two (2) or more vent connectors, from either power or natural draft units, may enter a common gas vent providing they conform to the requirements and tables of the National Fuel Gas Code, ANSI Z223.1/NFPA 54- latest edition, or applicable provision of the local building code. None may be connected to equipment with a positive vent pressure.

C. Locate unit as close to chimney as possible for shortest vent connector.

INSTALLATION

Determine height of chimney or B-Vent and length of lateral run. Select vent connector diameter from:

- 1). Table 1 or 2 of the National Fuel Gas Code, ANSI Z223.1 / NFPA 54- latest edition (see excerpts), or
- 2). Table G-3 of the Can /CGA - B149 Installation Code.

Install an adaptor at the flue outlet of the unit to step up to the diameter of the vent connector. Install elbow for vent connector, if required. This elbow should be full size of the vent connector. **DO NOT** install a three (3) inch elbow between the flue outlet on the unit and the adaptor. **DO NOT** use plastic vent pipe in any part of the chimney vent connection.

Install vent connector between elbow, if used, and chimney. Pitch vent connector up toward chimney $\frac{1}{4}$ " per foot of lateral run. Secure all joints with sheetmetal screws.

ALTERNATE VENTING METHOD (Canada Only)

The Heatmaker may be vented vertically up thru a masonry chimney using a 4" diameter ULC Certification Flexible Stainless Steel Vent.

Observe the following requirements:

- 1). The flexible vent must be run from the boiler up thru the entire chimney.
- 2). The chimney must terminate with a suitable vent cap.
- 3). If chimney is exposed, the vent pipe should be insulated.
- 4). The vent pipe must be installed with a $\frac{1}{4}$ " per foot upward slope from the boiler to the chimney.
- 5). The vent pipe must be supported every 3' to prevent sagging.
- 6). All joints in the vent must be secured with at least two corrosion resistant screws and sealed with an approved silicone sealant and checked for gas tightness.
- 7). The vent system should be checked once a year by a qualified serviceman.

Note: Boiler may not be vented in common with another gas appliance or be vented using B-vent.

Figure 3. HW-M2.

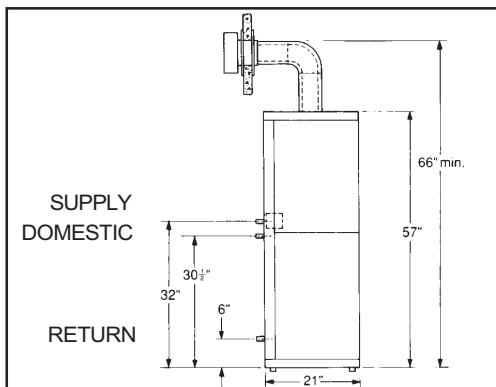

Figure 4. H-M2.

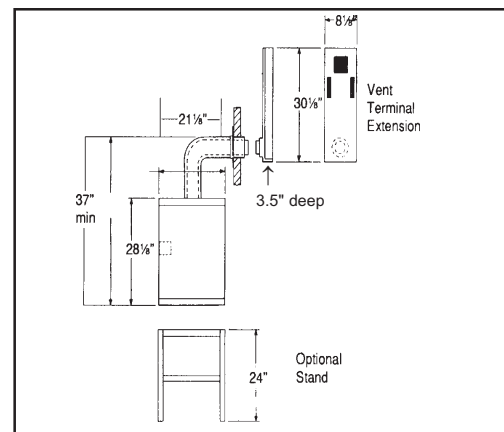

Table 1.

Capacity of Type B Double-Wall Vents with Single Wall Metal Connectors Serving a Single Category I Appliance.

| Height | Lateral | Vent and Connector Diameter (A & D) | | | | | |
|--------|---------|-------------------------------------|-----|------------|-----|------------|-----|
| | | 4" | | 5" | | 6" | |
| | | Appliance Rating in MBH | | | | | |
| H | L | Fan Assist | | Fan Assist | | Fan Assist | |
| (ft) | (ft) | Min | Max | Min | Max | Min | Max |
| 6 | 0 | 59 | 151 | 85 | 249 | 126 | 373 |
| | 2 | | | 85 | 156 | 123 | 231 |
| | 4 | | | 102 | 152 | | |
| | 6 | | | 114 | 147 | | |
| 8 | 0 | 58 | 164 | 83 | 273 | 123 | 412 |
| | 2 | 59 | 108 | 83 | 176 | 121 | 261 |
| | 5 | 77 | 102 | 107 | 168 | | |
| | 8 | | | 122 | 161 | | |
| 10 | 0 | 57 | 174 | 82 | 293 | 120 | 444 |
| | 2 | 59 | 117 | 82 | 193 | 119 | 287 |
| | 5 | 76 | 111 | 105 | 185 | | |
| | 10 | 97 | 100 | | | | |
| 15 | 0 | 56 | 190 | 80 | 325 | 116 | 499 |
| | 2 | 57 | 136 | 80 | 225 | 115 | 337 |
| | 5 | 75 | 128 | 102 | 216 | | |
| | 10 | 95 | 116 | 128 | 201 | | |
| 20 | 0 | 54 | 200 | 78 | 346 | 114 | 537 |
| | 2 | 56 | 148 | 78 | 248 | 113 | 375 |
| | 5 | 73 | 140 | 100 | 239 | | |
| | 10 | 93 | 129 | 125 | 223 | | |
| 30 | 0 | 53 | 211 | 76 | 372 | 110 | 584 |
| | 2 | 55 | 164 | 76 | 281 | 109 | 429 |
| | 5 | 72 | 157 | 98 | 271 | | |
| | 10 | 91 | 144 | 122 | 255 | | |
| 15 | 115 | 131 | | | | | |

NOTE: TABLES APPLY TO MODEL H(W)-M2 130 (CATAGORY 1) APPLIANCES ONLY.

Table 2.

Capacity of Masonry Chimney Flue with Type-B Double Wall Flue Connector Serving a Single Category Appliance.

| Height | Lateral | Type B Double Connector Diameter to be used with chimney areas within the size limits at bottom | | | |
|--|---------|---|-----|------------|-----|
| | | 7" | | 8" | |
| | | Appliance Rating in MBH | | | |
| H | L | Fan Assist | | Fan Assist | |
| (ft) | (ft) | Min | Max | Min | Max |
| 10 | 2 | | | 68 | 519 |
| 15 | 2 | 53 | 475 | 64 | 613 |
| | 5 | | | 99 | 594 |
| | 10 | | | 126 | 565 |
| 20 | 2 | 51 | 522 | 61 | 678 |
| | 5 | 80 | 503 | 95 | 658 |
| | 10 | | | 122 | 627 |
| 30 | 2 | 47 | 581 | 57 | 762 |
| | 5 | 75 | 561 | 90 | 741 |
| | 10 | | | 115 | 709 |
| 50 | 2 | | | 51 | 840 |
| | 5 | | | 83 | 819 |
| Minimum Internal Area of Chimney Square Inches | | 50 | | 63 | |
| Maximum Internal Area of Chimney Square Inches | | 269 | | 352 | |

NOTE: DERATE "FAN MAX" CAPACITY IN TABLE 2 BY 20% WHEN SIZING FLEXIBLE METAL FLUELINERS.

Figure 5. (Tile Lined Chimney).

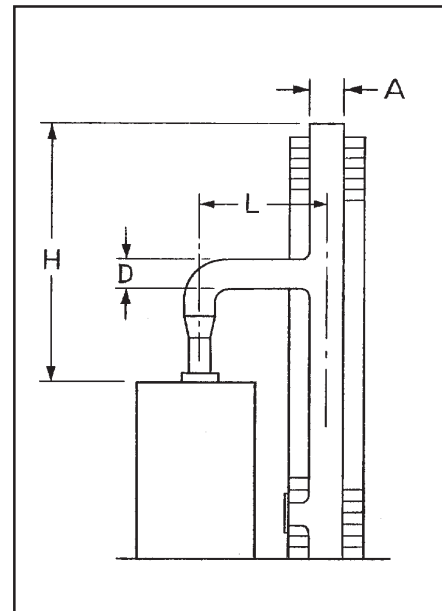

Masonry Chimney Serving a Single Category I Appliance. (See Table 2).

**INSTALLING STAINLESS STEEL
HORIZONTAL / VERTICAL VENTING
(NON CONCENTRIC)**

Stainless Steel Special Gas Vent listed to U.L. Standard 1738 and U.L.C. Standard 636 may be used to vent all Heatmaker H(W)(P) and DH(P) models. Vent pipe and fittings are manufactured to these Standards by Heat-Fab, Inc. under the trade name of Saf-T Vent® and by Z-Flex™ under the trade name of Z-Vent. Follow the Special Gas Vent manufacturers' instructions regarding design, location and assembly of the vent system.

Table 3.

| Appliance Design Data (single pipe only) | |
|--|------------------------------|
| Minimum clearance from combustibles (vent) | 3" |
| Max. flue gas temp. | 325°F |
| Max. vent pressure | 1.5" W.C. |
| Max. equiv. ft of venting (any combination of horiz. or vert.) | 50 equiv. ft 3" diameter |
| Max. equiv. ft of venting (any combination of horiz. or vert.) | 100 equiv. ft 4" diameter |

The Heatmaker appliance may be vented with any number of elbows or fittings provided that the maximum equivalent feet of venting is not exceeded. 90° elbows in the vent system shall be considered to be 10 equivalent feet. When vented with Special Gas Vent, the Heatmaker must not be common vented with any other appliance.

**CONNECTING SPECIAL
GAS VENT TO HEATMAKER**

Heatmaker part number 2400-372 (Figure 6) is used to secure the Special Gas Vent to the flue outlet of the Heatmaker*. Heat-Fab pipe or fittings (Heatmaker part numbers 2400-350 or 2400-352) or the male end of Z-Vent pipe (Z-Vent # 02 SVEPXX030) may be installed over the flue outlet of the Heatmaker.

*If a duct is used around the Special Gas Vent to bring in combustion air from another location, the connection of that duct to the appliance must be secured with sheetmetal screws.

Each joint between the appliance and the last joint before the location where the Special Gas vent exits the duct must also be secured with sheetmetal screws.

In this application, part number 2400-372 is not used at the boiler flue collar. It is used, and must be used, to secure the Special Gas Vent at the point where the Special Gas Vent exits the duct.

The combustion air supply should be protected from debris entering the duct. This may be done with a Heatmaker Vent Terminal, part number 2400-277, as shown in Figure 7 or with a large mesh screen.

Follow the Special Gas Vent manufacturer's instructions for

cleaning and sealing all parts before assembling.

**APPLIANCE JOINT
PROCEDURE WITH HEATMAKER**

PART #2400-350 (SEE FIGURE 8)

Apply 1/4" bead of silicone sealer (GE108 or Novagard 400) to the 3 inch (3") flue outlet of the Heatmaker approximately one inch (1") from the end.

Slide flue adapter over the Heatmaker flue outlet (flared up end) and push down to stop (do not force adapter beyond stop).

Apply another bead of silicone around this joint and smooth out.

Apply 1/4" bead of silicone to the straight end of the 2400-350 pipe approximately 1/4" from the end.

Slide the pipe into the adapter until it bottoms in the adapter.

Apply another bead of silicone around this joint and smooth out.

**APPLIANCE JOINT
PROCEDURE WITH HEATMAKER**

PART #2400-352 OR Z-VENT

#02SVEPXX030 (SEE FIGURE 9)

Apply 1/4" bead of Silicone sealer (GE 108 or Novagard 400) to the 3 inch (3") flue outlet of the Heatmaker approximately one inch (1") from the end.

Slide pipe over the Heatmaker flue outlet and push down to stop (do not force pipe beyond stop).

Apply another bead of silicone around this joint and smooth out.

SECURING SPECIAL GAS VENT

Attach Heatmaker part number 2400-372 to 5" collar on appliance or end of five inch (5") combustion air duct and tighten large clamp.

Form tabs on part number 2400-372 onto Special Gas Vent pipe and secure tabs with the 3" clamp.

After the clamp has been tightened, fold the end of the tabs down over the clamp.

DO NOT use screws in any portion of the 3" Special Gas Vent.

For vertical venting see instructions in the Vertical Vent Kit pertaining to use of raincaps and condensate drip tee's.

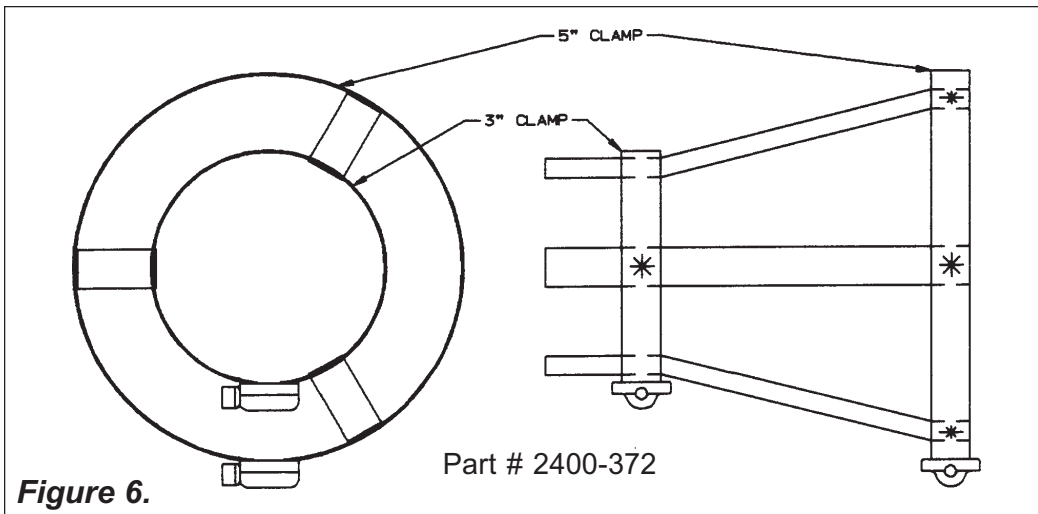

Figure 6.

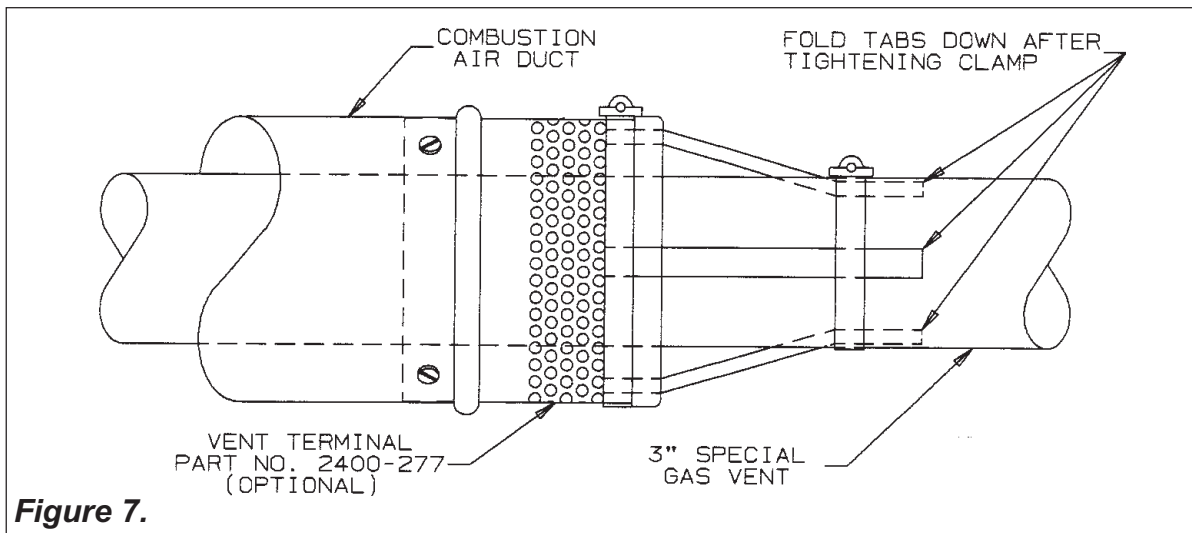

Figure 7.

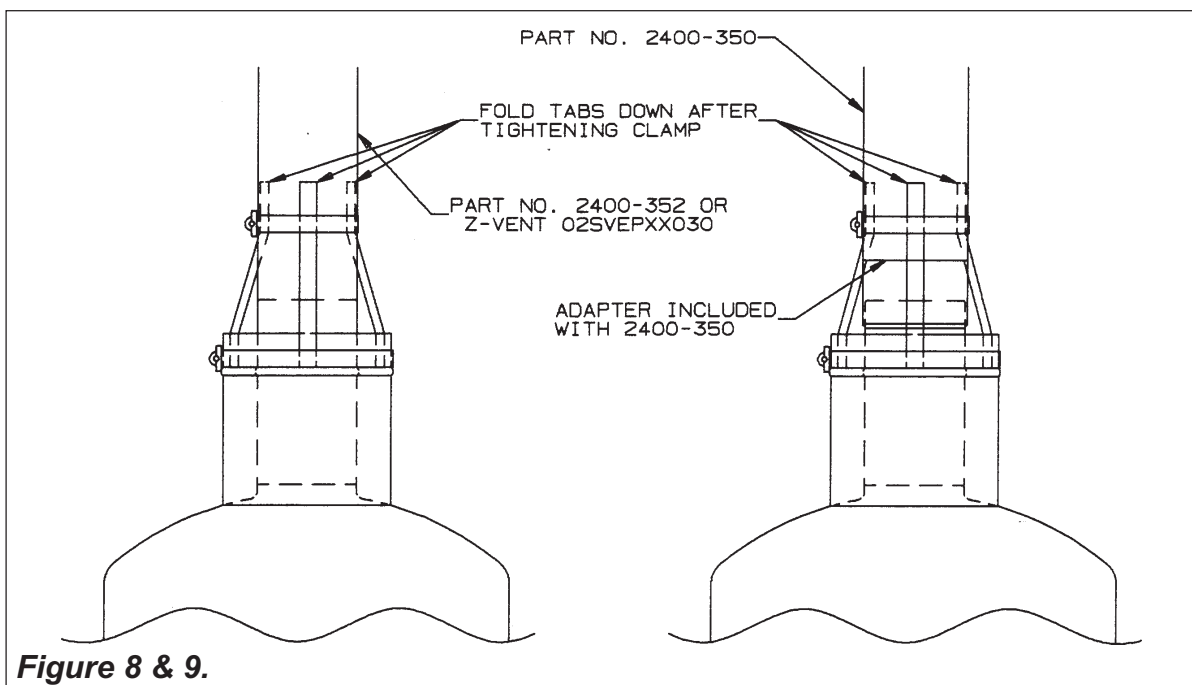

Figure 8 & 9.

THE DIRECT VENT KITS

(PART NUMBERS 2400-326 or 2400-328)

When using the Direct Vent Kit, the Heatmaker is a sealed combustion unit. All of its air is drawn in from the outside through the 5" outer pipe. Flue gases are vented through the 3" vent pipe positioned inside the 5" intake pipe. The hot flue gases are surrounded by the intake flow of cooler outdoor air. This vent system may be installed through, and be in contact with, combustible materials.

INSTALLING DIRECT VENT KITS

The Direct Vent Heatmaker is certified with a maximum of 15 linear feet of vent pipe and one set of elbows. Systems may be vented with a maximum of three sets of concentric elbows providing the maximum length is reduced by three linear feet for each additional elbow set. Provide a minimum of 16" above the top of the boiler for vent installation and servicing. There are two vent kits available. Part numbers 2400-326 and 2400-328 provides all of the required materials. Part number 2400-326 for vent installations which require adjustable height and horizontal run. This kit will permit vertical and horizontal lengths of pipe from 2' or 4'. One foot extensions and 2' to 4' extensions are available to increase vent lengths to the maximum allowed. Additional sets of elbows are also available.

Part number 2400-328 provides all of the required materials for vent installations which may have a fixed height of 11 inches and an adjustable horizontal run of 2' - 4'. Accessories for P/N 2400-326 also fit P/N 2400-328.

LOCATING THE VENT ON AN OUTSIDE WALL

Exterior vent should terminate 16½" above grade, and at least 13 ½" from any other building opening such as doors, windows, etc. Units terminating below the top of the boiler must reduce allowable vent length by 1" for every foot of vertical drop below the top.

Vent opening should be well away from shrubbery or other obstructions that would prevent free air flow to and from vent terminal. Do not terminate vent under decks, stairways, or car ports. When ever possible, locations under windows should be avoided.

NOTE: Should it be impossible to locate opening center line 16 ½" above grade, use optional Vent Terminal Extension (Part Number 2400-278). Fig. 4.

Vent terminals must also be at least 3' above any forced air inlet located within 10', and at least 7' above grade when located adjacent to a public walkway, and cannot terminate in a location where condensate or vapor may be a nuisance, hazard, or could be a detriment to other equipment. Vent terminals must have a minimum clearance of 4 feet horizontally from, and in no case above or below electrical meters, gas meters, regulators, and relief equipment unless a 4 foot horizontal distance is maintained .

Do not locate the vent terminal where blockage by snow is a possibility, or where flue products could strike against building materials and cause degradation.

AIR SOURCE FOR COMBUSTION (WHEN NOT DIRECT VENTED)

When using these venting methods the Heatmaker draws all combustion air through the top of the unit and from the space around the boiler. When locating the unit in unconfined spaces in buildings, infiltration may be adequate to provide air for combustion and ventilation; however, in buildings of unusually tight construction, or when locating the unit in a confined space, additional air should be provided and the following guidelines must be followed.

1. If the space is in a building of unusually tight construction, air should be obtained from outdoors, or from spaces which freely connect with outdoors.
2. For boilers in confined rooms, two permanent openings shall be provided - one within 12" of the ceiling, and one within 12" of the floor of each room. Each opening shall be at least one square inch per 1,000 BTU/HR boiler input, but not be less than 100 square inches. These openings shall freely connect with areas having adequate infiltration from outside.
3. When all air is provided from outdoors, the confined space shall be provided with two openings as outlined above. These openings shall connect directly, or by ducts, with outdoors or spaces (crawl or attic) that freely connect with the outdoors, and shall be of the size listed below for that particular arrangement.
 - a. One square inch of free area per 4,000 BTU/HR of boiler input for direct outdoor air supply through an outside wall, or through vertical ducting directly to outside.
 - b. One square inch of free area per 2,000 BTU/HR of boiler input for direct outdoor air through horizontal ducting.
 - c. All ducting shall be of the same size as the opening to which it is connected.

Figure 11.

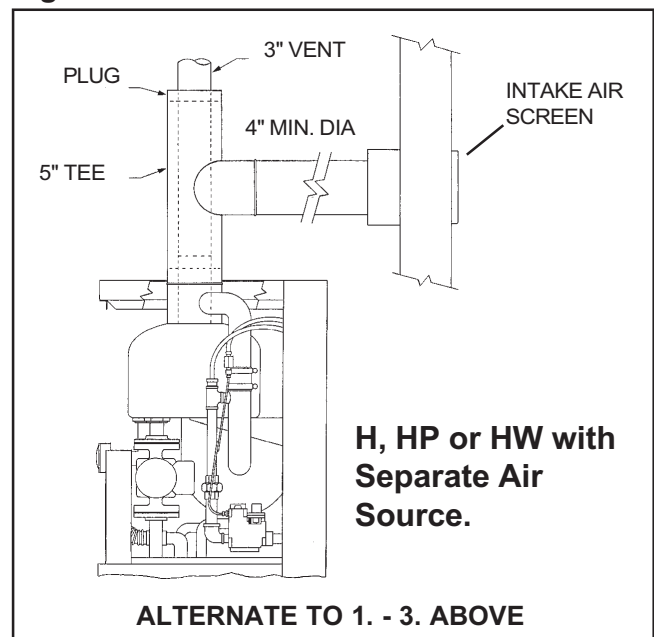

GAS CONNECTION TO HEATMAKER

A. The Heatmaker requires an inlet gas pressure of at least 4" W.C and no greater than 13" W.C. Check with your local gas utility or supplier for availability of this pressure range.

B. Referring to Table 4, size supply piping to minimize pressure drop between meter or regulator and unit.

C. Run gas supply line in accordance with all applicable codes. IF UNIT IS INSTALLED ABOVE GAS SUPPLY, RUN PIPING UP TO A POINT ABOVE VENT CENTER LINE AND BACK DOWN TO UNIT. THIS WILL PREVENT WATER FROM ENTERING GAS SUPPLY SHOULD A LEAK DEVELOP IN THE BOILER SECTION. (See Figure 12).

D. Locate and install manual shutoff valves in accordance with state and local requirements.

E. Install drip leg, ground joint union and drip cap to trap sediment and for test gauge access (Figure 12).

F. Support all piping with proper hangers.

G. All threaded joints should be coated with piping compound resistant to action of liquified petroleum gas whether LPG is used or not.

H. The boiler and its individual shutoff valve must be disconnected from the gas supply piping system during any pressure testing of that system at test pressures in excess of 1/2 psig (3.5kPa).

The boiler must be isolated from the gas supply piping system by closing its individual manual shutoff valve during any pressure testing of the gas supply piping system at test pressures equal to or less than 1/2 psig (3.5kPa).

I. The boiler and its gas connection must be leak tested before placing the boiler in operation.

J. Purge all air from gas lines.

K. Note: Heatmaker's are certified for 4" to 13" W.C. We find on L/P the unit performs better when the low pressure regulator is not set over 9" W.C. Use an appliance regulator (maxitrol RV48 or equivalent) if more than 3" lock up occurs in gas supply.

DOMESTIC WATER PIPING (Figure 13.)

1. Connect hot water tempering valve (12) "HOT" port to hot water outlet from unit. This valve should be mounted 3" to 6" below the outlet and set for 120° F mixed delivery temperature or as local codes dictate. HEATMAKER RECOMMEND ANTI SCALD VALVE SUCH AS SPARCO OR DANFOSS.

2. Connect gate or shutoff valve (13) to tempering valve (12) "MIX" port, and cold water inlet.

3. Install supplied flow restrictor (14) ahead of mix valve tee.

4. Connect pressure relief valve (1) (if required by codes), maximum 150 PSI as close to the unit as possible. No other valves or restrictions may be installed between the Heatmaker and the relief valve.

(DONOT USE A TEMPERATURE/PRESSURE RELIEF VALVE AS THIS IS NOT A STORAGE HOT WATER HEATER).

*Model 60 is not recommended for larger hot water demands.

Warning: Failure to install a hot water tempering valve (12) creates a scalding hazzard with potential for serious bodily injury. Some brands of tempering valves are not designed as anti scold valves.

INSTALLATIONS WITH WATER CONTAINING 10 GRAINS OF HARDNESS OR HIGHER, MUST BE INSTALLED WITH APPROPRIATE WATER TREATMENT.

Figure 12.

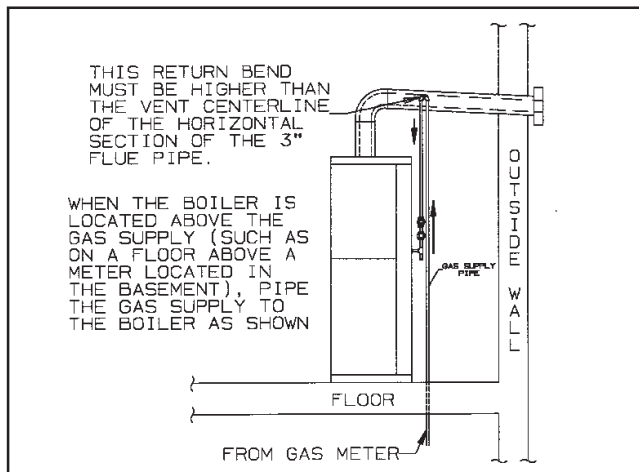
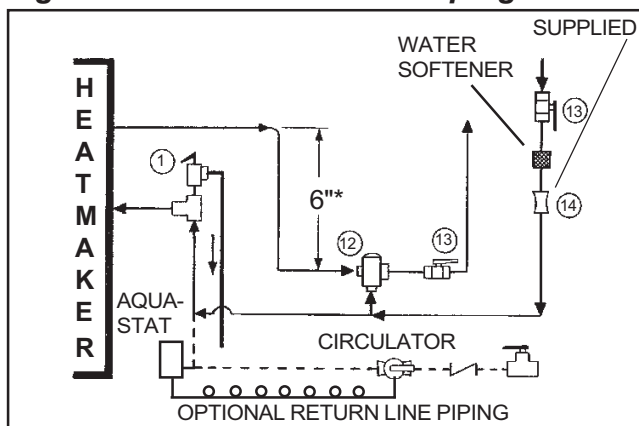

Table 4.

| Length of Pipe | Capacity of Pipe in MBTU / HR (.6 Specific Gravity) | | | |
|--|--|------|------|--------|
| | 1/2" | 3/4" | 1" | 1 1/4" |
| 10' | 132 | 278 | 520 | 1,050 |
| 20' | 92 | 190 | 350 | 730 |
| 30' | 73 | 152 | 285 | 590 |
| 40' | 63 | 130 | 245 | 500 |
| 50' | | 115 | 215 | 440 |
| 75' | | 93 | 175 | 360 |
| 100' | | 79 | 150 | 305 |
| 150' | | 64 | 120 | 250 |
| Additional length to be added for each tee or bend | 1.3' | 1.7' | 2.2' | 2.7' |

Figure 13. Domestic Water Piping.



* or per valve manufacturers instructions.

HYDRONIC HEAT PIPING - H SERIES

Hydronic Connections, Fittings and Accessories. Refer to Fig. 16, page 12.

NOTE: A SEPARATE HEATING CIRCULATOR MUST BE PROVIDED IN SYSTEM PIPING, FOR ALL MODELS.

1. Connect system supply to 1" supply connection (A).
- 1a. Install thermostatic union (supplied) on H, HP boilers.
2. Pipe the discharge of the relief valve, full size, to a drain or in a manner to prevent injury in the event of pressure relief.
3. Install an air purger (2) in supply line at or above pipe height.
4. Install automatic float type air vent (3) on air purger.
5. Connect diaphragm type expansion tank (5) to air purger.
6. Install a boiler drain valve (8) adjacent to unit in return line.
7. Connect system return to 1" return connection (B).
8. Install a properly sized circulator (9) with optional isolation valves (10).

CAUTION: All hot water pipes must be installed with a minimum 1" clearance from combustible materials.

NOTE: H, HP boilers installed in radiant (in floor) systems and other low mass systems should be provided with a buffer tank to assure constant supply temperature without excessive boiler short cycling (Figure 17).

FEEDWATER MAKE-UP

1. Connect boiler feed water supply with shut off valve to inlet connection of automatic fill valve (4).
2. If codes require, install suitable back-flow preventer (11) between automatic fill valve and city main.
3. To ensure sufficient expansion volume of the hydronic system water due to heat-up and cool-down during normal operation, a #30 or larger expansion tank must be used on all HW series applications.

HYDRONIC PIPING

HW SERIES

HW-M2 boilers are installed in single and multiple zone systems (using either zone valves or zone circulators) in the same manner as any other residential boiler. Systems with zone circulators or single zone systems require the installation of a hydronic flow check (6) to prevent gravity circulation of heating supply water when no heat is

desired.

To minimize heat loss from the storage tank (HW) during standby periods, it is recommended that the piping between the Heatmaker up to and including the vertical leg be insulated with 1/2" - 3/4" of insulation.

CAUTION: Unless equipped with optional stainless steel tank, the HW model must not be direct connected to a heating system utilizing oxygen permeable tubing, (see warranty). Provide a water to water heat exchanger between systems to prevent corrosion of tank or other components.

Nontoxic heating system antifreeze may be added to the hydronic system provided that the concentration does not exceed 35% and the antifreeze contains an anti-foamant.

USING IN A COMBINED HOT WATER HEATING AND CHILLED WATER COOLING SYSTEM.

When the Heatmaker is used in connection with a refrigeration system, it must be installed so that the chilled medium is piped in parallel with the boiler with appropriate valves to prevent the chilled medium from entering it.

The boiler piping system of a Heatmaker boiler connected to heating coils located in air handling units where they may be exposed to refrigerated air circulation must be equipped with flow control valves or other automatic means to prevent gravity circulation of the boiler water during the cooling cycle.

Figure 14. Hydronic Piping (HW).

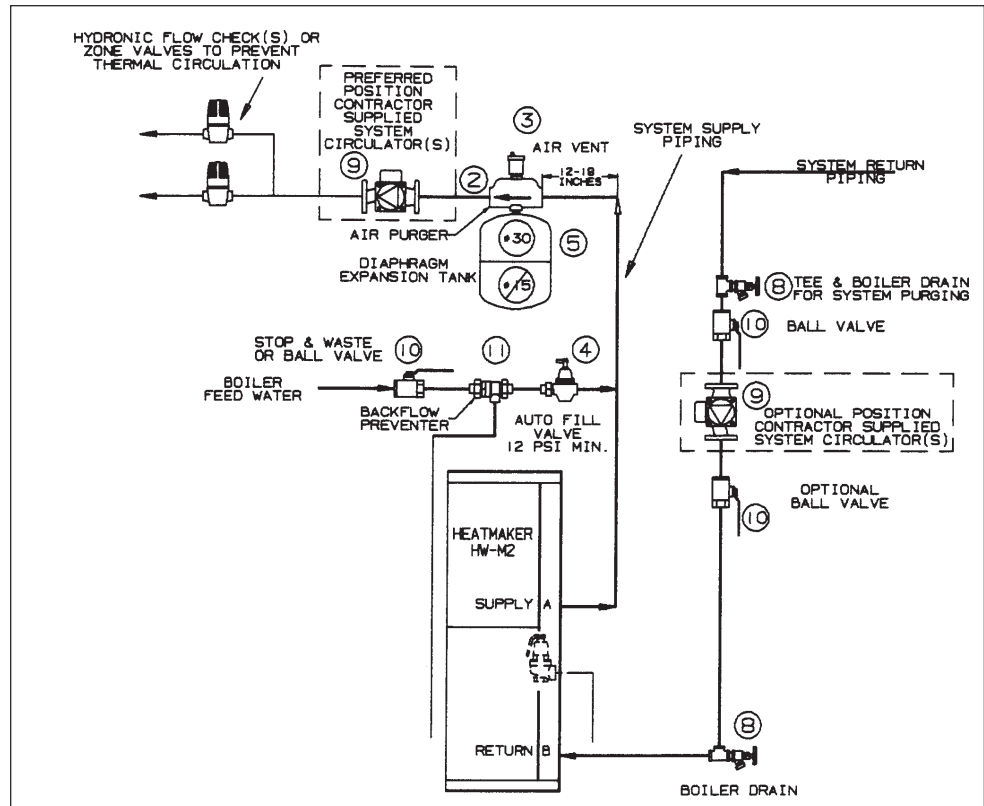

Figure 15. Hydronic Piping with Indirect H(P).

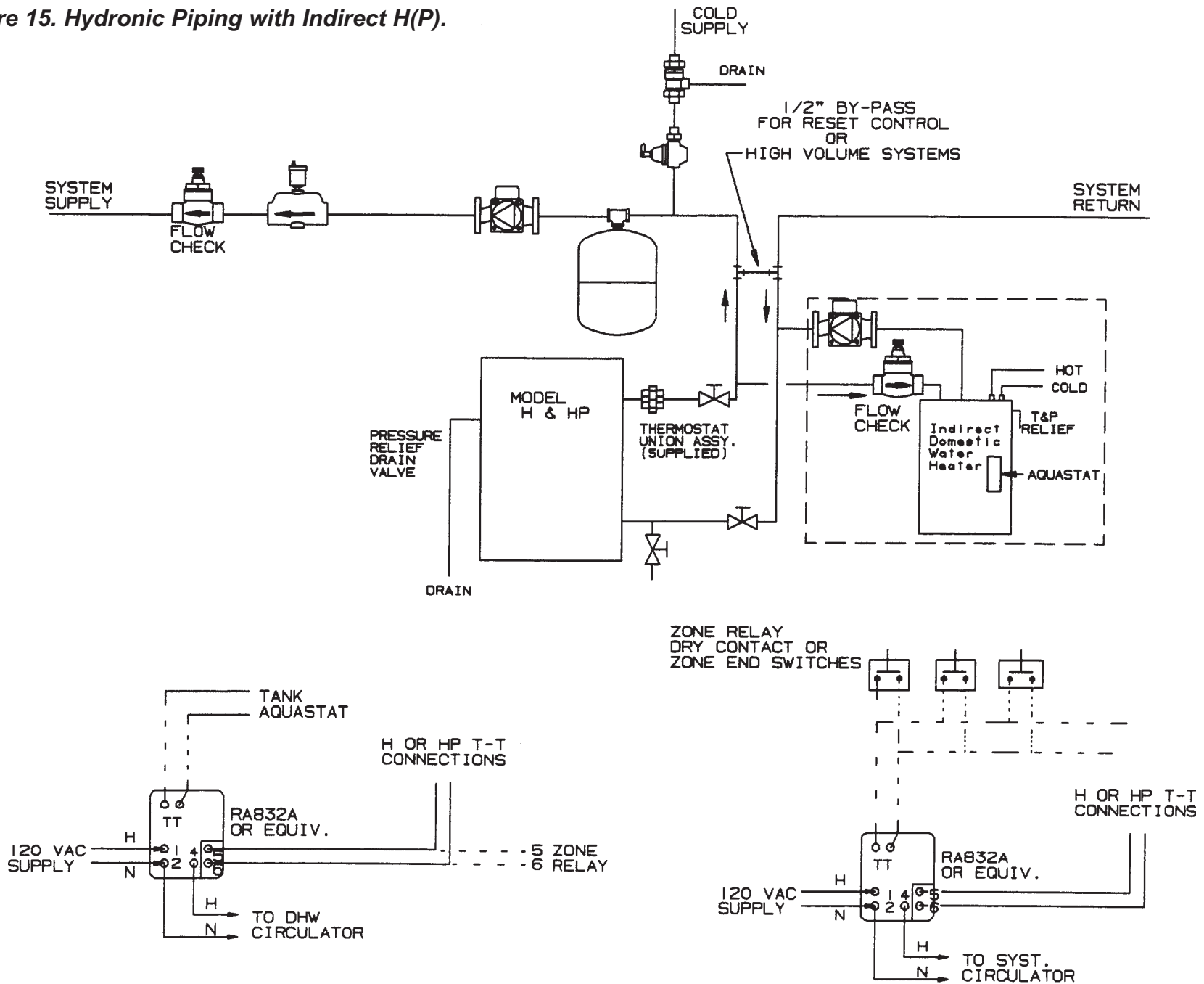

Figure 16. Hydronic Piping H(P) Models.

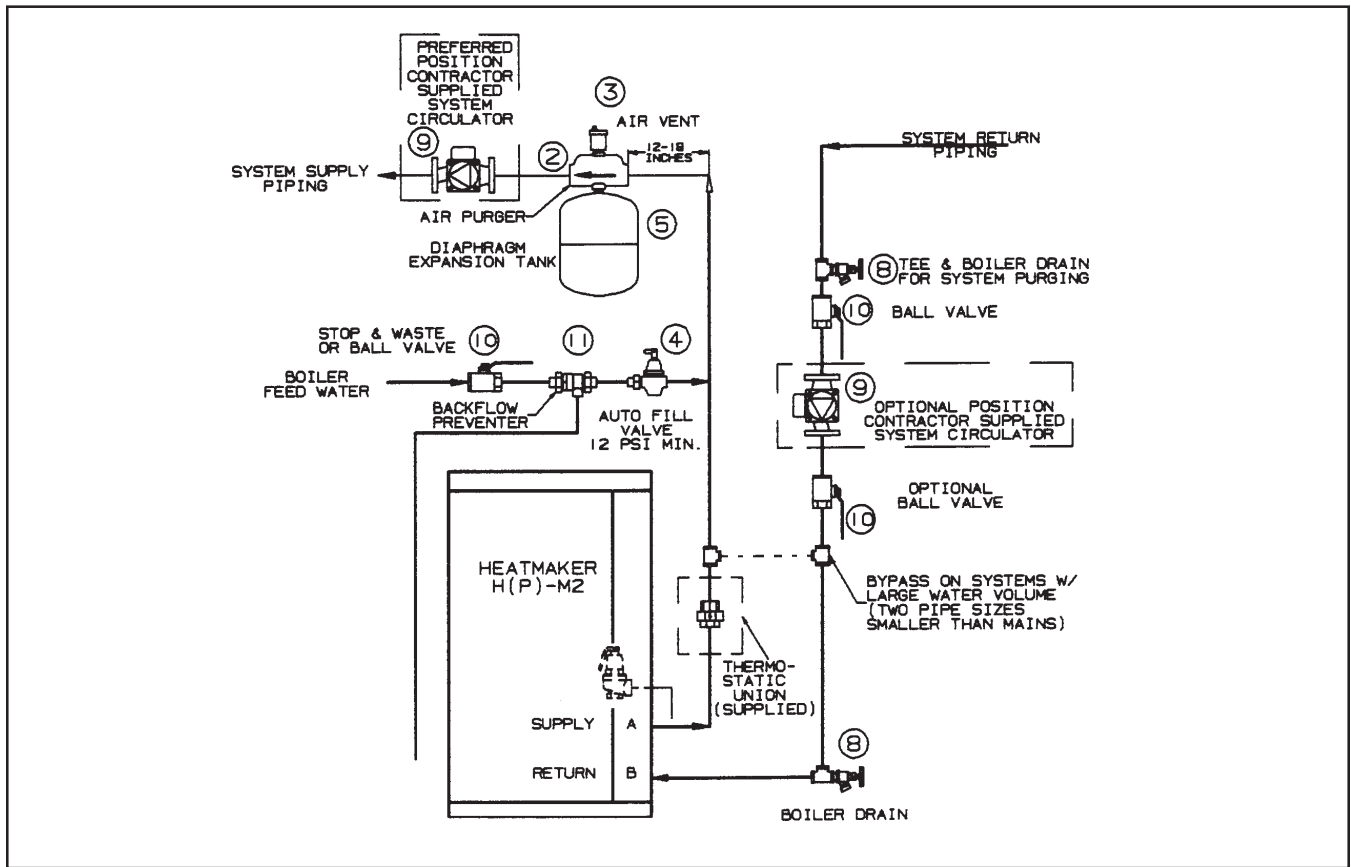
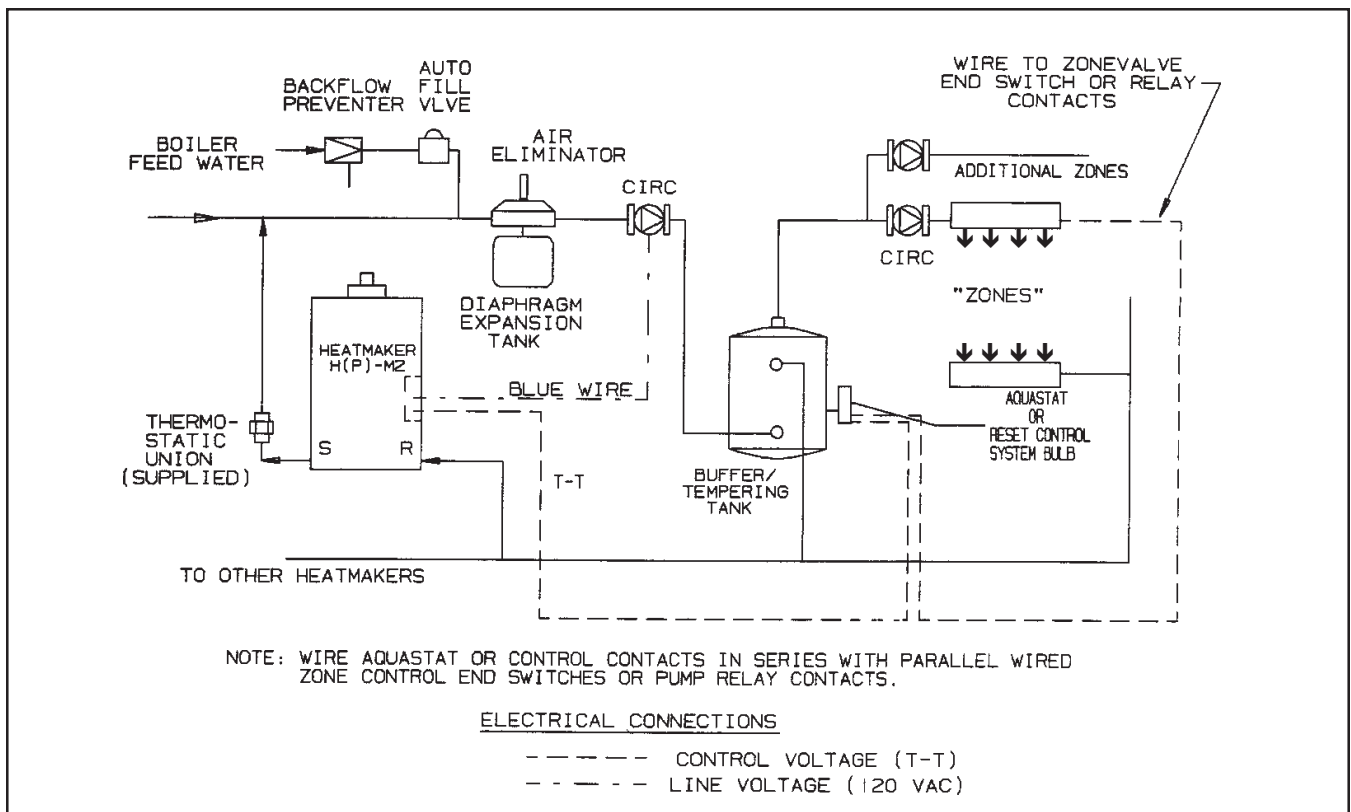

Figure 17. Hydronic Piping H(P) in Radiant "in floor" or Low Mass Heating Systems



ELECTRICAL CONNECTIONS

All electrical wiring must conform to local codes and/or the

- 1). National Electric Code or
- 2). Canadian Electrical Code - Part 1.

The unit must be electrically grounded in accordance with the requirements of the authority having jurisdiction or, in the absence of such requirement, with the 1). National Electrical Code. ANSI/NFPA NO.70- latest edition, or the CSA Standard C22.1 "Canadian Electrical Code - Part 1".

Single pole switches, including those of safety controls and protective devices must not be wired in a grounded line.

All electrical connections are made in the field wiring box which is located on the right side of the unit.

NOTE: All internal electric components have been pre-wired. No attempt should be made to connect electric wires to any other location except the wiring box as described below.

1. Main power

Connect a 15 amp fused 120 volt supply to the main power switch illustrated (hot leg is connected directly to switch). Neutral leg to white wire. Ground wire can be connected to the grounding screw in the box or on the switch.

2. For single zone installations, connect room thermostat (T-T) wires to the red and white/red wires. Connect circulator (120 volt, 5 amps maximum) between the blue wire and the white wire (neutral) per Fig. 18. Set **thermostat** anticipator to 0.9 amps.

3. Zone Valves and Thermostats: Fig 19 (Fig 20 for 3 wire zone valve such as TACO) or DC magnetrol valves.

Install external 24 volt transformer of sufficient V.A. to power combined load of zone valves. Consult zone valve manufacturer's instructions. Connect circulator (120 volt, 5 amp maximum) between the blue wire and the white wire (neutral).

4. Multi-Zone/ Multi-Relay-Circulator Installations: Fig. 21 Multiple circulators must not exceed 5 amps when connected to blue wire. Blue wire must be used on all HW series.

NOTE: On zone valve systems such as Taco, Automag and others which do not have isolated (dry) contact end switches, a single pole isolating relay must be utilized. (Fig. 20).

| LEGEND | |
|--------|---|
| S1 | Disconnect Switch |
| TH1 | 24-Volt Thermostats. |
| TH2 | |
| TH3 | |
| C1 | Zone Circulators - Max 5 AMP 120 VAC. |
| C2 | |
| C3 | |
| R1 | Zone Relays. Honeywell R845A or equivalent. |
| R2 | |
| R3 | |
| ZV1 | Zone Valves. Honeywell V8043 or equivalent. |
| ZV2 | |
| ZV3 | |

Figure 18. Single Zone.

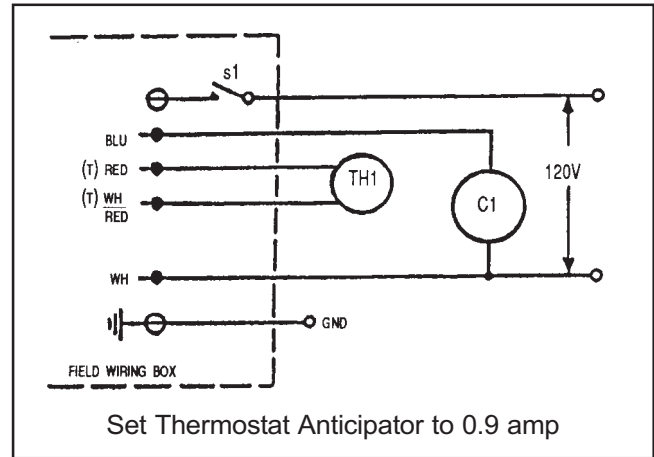

Figure 19. Zoning with Zone Valves.

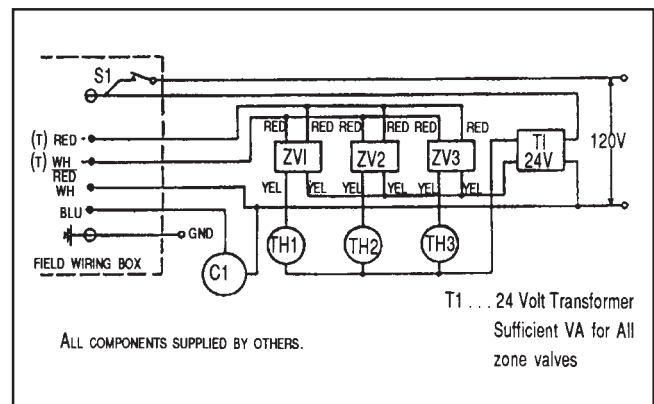

Figure 20. Zoning with 3 wire Zone Valves.

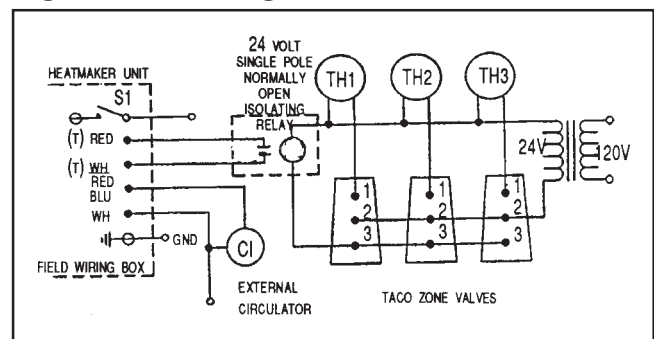
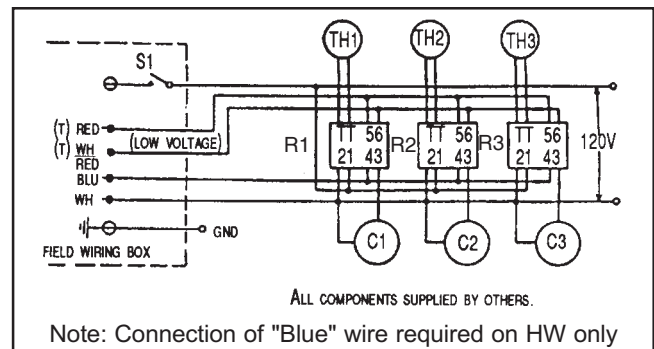

Figure 21. Zoning with Circulators.



The Model HP-M2-Series may be used as either a Paloma Pak/Hytech boiler replacement or as a new wall-mount installation. Carefully unpack HP unit. Read all installation instructions before starting the installation. Remove the Front removable jacket and find the plumbing accessories package inside the unit.

**WALL MOUNTING INSTRUCTIONS
PALOMA/HYTECH REPLACEMENT**

Hang the HP-M2 as assembled from the manufacturer onto the existing wall bracket. Do not remove the brackets which are attached to the new unit. If the existing wall bracket does not align with the slotted mounting holes on the rear of the HP-M2, remove the old bracket from the wall and follow instructions for new wall mount below.

NEW WALL MOUNT INSTALLATION

Remove the bolts, nuts and washers that secure the two mounting brackets to the bottom and rear of the HP-M2 cabinet. Remove the U-channel spacer bracket from each wall bracket and discard. (Spacer brackets are used only with original bracket in Paloma Pak/Hytech retrofit installations)

Attach the included mounting template to the selected wall location. Mark and drill holes for appropriate mounting hardware at the template specified locations. Remove template from the wall and securely affix the two wall brackets to the wall surface with appropriate mounting hardware (provided by installer).

Lift the HP-M2 onto the wall brackets and re-assemble the bolts, nuts and washers to affix the unit onto the wall brackets.

NOTE: DONOTREINSTALLTHEU-CHANNELSPACERBRACKETSWHENMOUNTINGTHEWALLBRACKETSDIRECTLYTOAWALL.

HYDRONIC SYSTEMS CONNECTIONS

The HEATMAKER HP-M2 Series is supplied with the necessary fittings to match the Paloma Pak supply and return piping. If the original wall bracket is compatible with the slotted mounting holes on the rear of the HP-M2, the supply and return pipe unions attach directly to the existing piping. If the installation is new or if the old bracket is incompatible or unusable, the return and supply connections will require re-piping to match the HP-M2 connections.

PLUMBING ACCESSORIES INSTALLATION

- 1) Attach boiler drain plumbing accessory to the labeled "return" on the bottom of the HP-M2.
- 2) Separate Thermostatic Union Assembly halves and thread the 1" nipple side to the labeled "supply" on the bottom of the HP-M2. Attach the remainder of the union assembly onto the top half of the union. Be sure to use appropriate thread sealers to assure leak-tight joints.
- 3)a. Where the HP-M2 is a direct replacement for a Paloma Pak/Hytech the installation is completed by connecting union halves together.
 b. If the installation is new, refer to the piping schematics and instructions on page 10 -12.

GAS SUPPLY CONNECTION

If the installation is a direct retrofit, the gas supply will require re-piping to connect to the HP-M2 gas inlet. If the gas is supplied from below the unit, be sure to run supply pipe to a point higher than the vent center line before connection to the unit gas valve.

On new installations refer to the gas piping section for gas pipe sizing and related information.

VENTING THE HP-M2-SERIES

The HP-M2 may be vented using any of the venting options available to the H(W)-M2-Series. These options include Direct Vent, Outside Air vented, Alternate horizontal/vertical venting (using "Special Gas Vent") or internal lined or "B" Vent type chimneys.

MODEL HP-M2-60 & HP-M2-100 MUST NOT BE CHIMNEY CONNECTED OR "B" VENT CONNECTED.

AGA

When used as a retrofit boiler vented into a chimney or a "B" Vent, be sure to check current vent and vent connector sizing tables. Only units fired at 130MBTU/hr may be vented with this option. Under no circumstances shall the HP-M2-60 be chimney connected or "B" vented using 3" vent or vent connectors. The unit 3" vent collar must be increased to a size which will accommodate the chimney system for the appropriate BTU/hr input of the boiler.

In the event the unit firing rate and masonry chimney parameters do not fall within the recommendations in the latest N.F.G.C.* chimney sizing tables, a flexible chimney liner may be utilized in the chimney. Sizing capacity for metal chimney liners may be obtained by 20% de-rating (or 80%) of the "fan max" capacity from B vent tables. See page 5 for vent table excerpts.

*National Fuel Gas Code ANSI Z223.1 / NFPA 54

CGA

Refer to page 4 for Alternate Venting Method.

ELECTRICAL CONNECTIONS

If the installation is new, wire the unit per the applicable wiring diagram for line voltage (120VAC) and control (24VAC) wiring connections.

Do not connect an external voltage source to the HP 24 volt (T-T) wires. Install an isolation relay if required per diagram Fig 20.

Where a HP-M2-Series in a Paloma Pak/Hytech retrofit is connected to a single zone system, the original transformer relay control-pak should be removed and all field wiring connected to the unit electrical connection junction box on the right side of the unit. The 120VAC power input, 120VAC system circulator output and thermostat should be wired as outlined in figure 18.

Be sure to set the thermostat heat anticipator to 0.9 amp for single zone connection.

If a retrofit installation includes multiple zones, any one of the options provided in this manual may be used, or the existing transformer relay control-pak may be utilized and re-wired according to the diagram below. Where two wire or three wire zone valves are used, this is the preferred wiring method on retrofits.

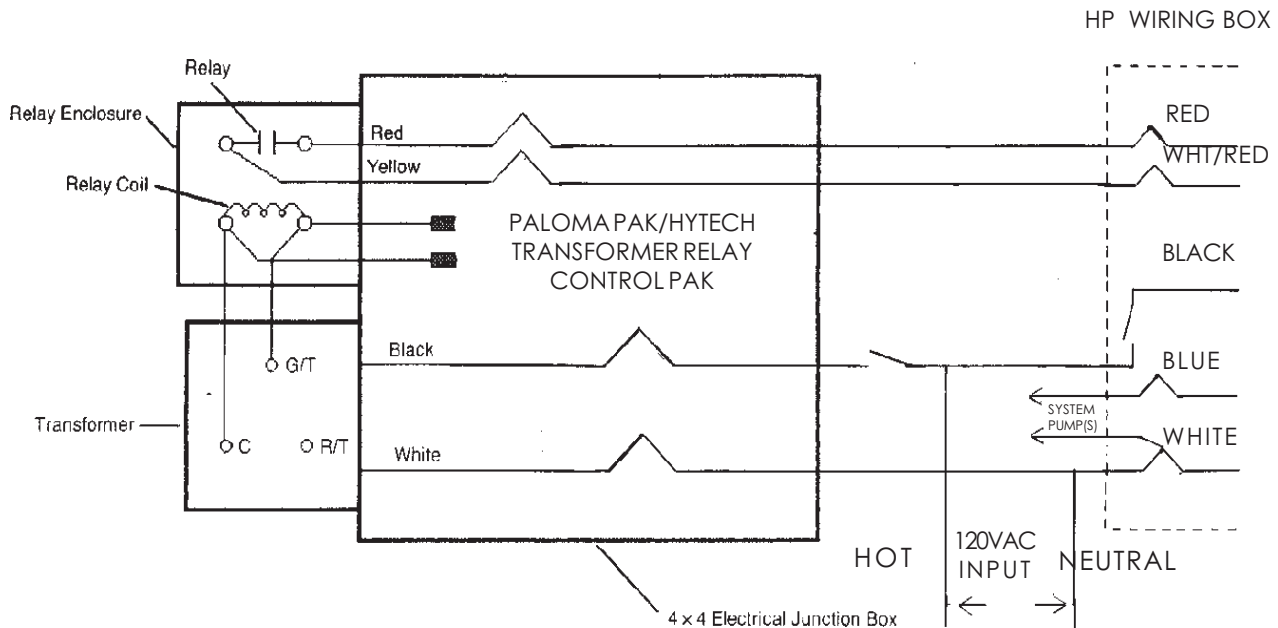

MANUFACTURED HOME (MOBILE HOME) APPLIANCE INSTALLATION INSTRUCTIONS.

These appliances are design certified to conform to the requirements of ANS Z21.10.3 for installation in manufactured homes (mobile homes) when installed in conformance with this manual supplement and the manual.

APPLIANCE MOUNTING

Model HP Series appliances are provided with a wall mounting bracket.

Model H Series appliances are provided with mounting holes in the base. Either lag bolts or through bolts must be used for secure attachment of the appliance to the structure.

Model HW Series appliances are attached to the structure by attaching angle brackets from the structure to the secured clearance brackets. See Figure 22.

Figure 22.

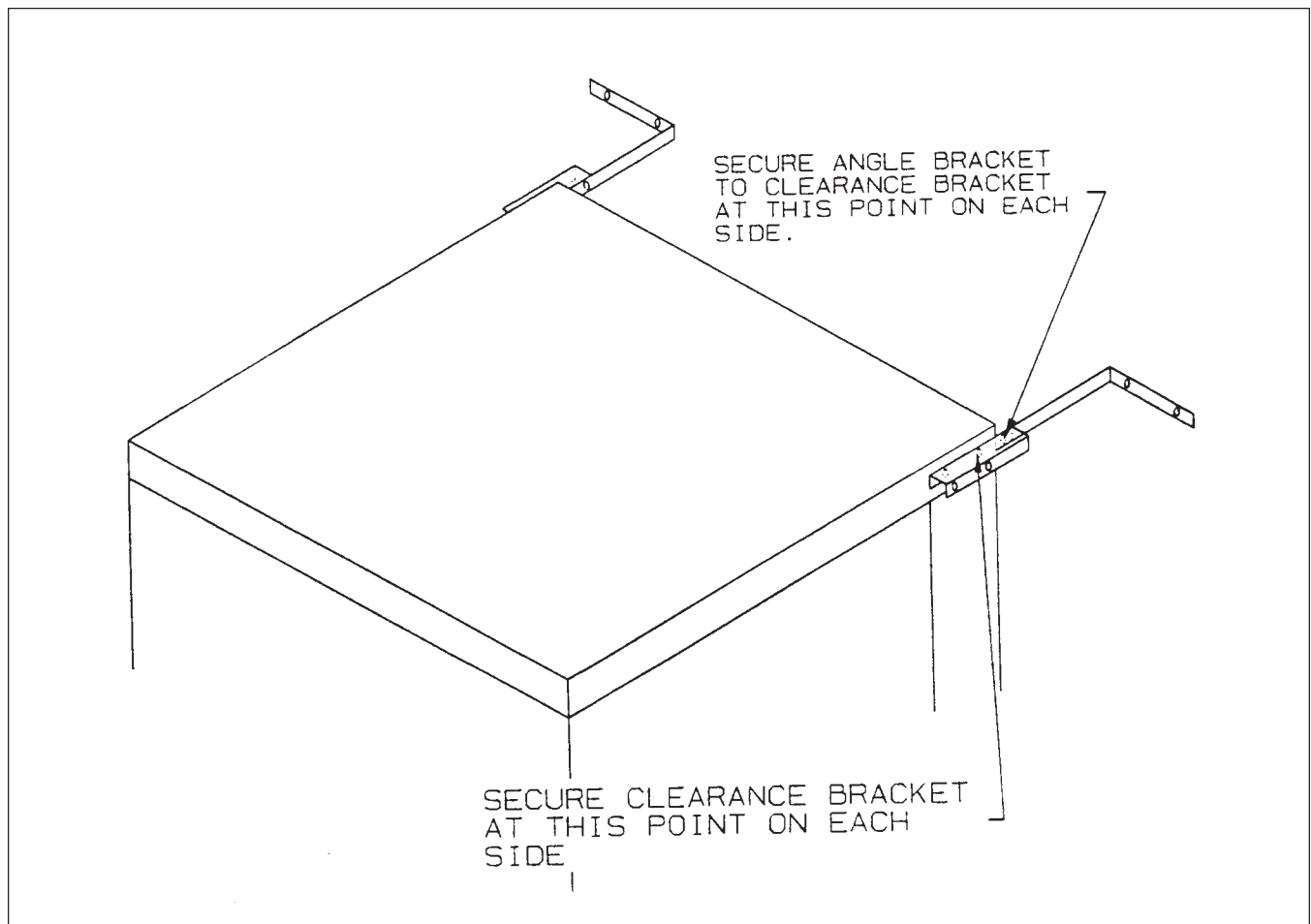

CHECK, TEST & START- UP

FILLINGSYSTEM

1. Open all supply and return valves.
2. Fill heating system to minimum operating pressure -12 psig.
3. Open bleed pet cock and bleed air from boiler coil until a good stream of water comes out. (H(P)-M2 series), Item 8 on page 33.
4. Purge all lines by opening vents, or with flushing valves.
5. Close gas valve.
6. Turn on 120 volt power, and listen for unit circulator to start. Unit will cycle off on lockout.
7. Open all vents again to discharge any additional air and close off after air is eliminated.
8. System is now ready for operation.

FIRINGBURNER

1. Be sure that system has been filled properly (see above) and is leak tight.
2. Open gas cock (s). Open manual gas shutoff valve by turning to "on" position.
3. Turn on main switch, and set thermostat to call for heat. In approximately 2 seconds, blower will come on.

NOTE: Burner may not ignite on first attempt because of air in gas lines. In this case, blower will stop after 5 minutes. Should this happen, turn off main switch. Wait 5 minutes and turn on main switch again.

4. If burner fails to ignite after three attempts, refer to Trouble Shooting Section 2, Service Manual or call service for troubleshooting.

CAUTION: SHOULD ANY PRONOUNCED ODOR OF GAS BE DETECTED, OR IF THE GAS BURNER DOES NOT APPEAR TO BE FUNCTIONING IN A NORMAL MANNER, CLOSE MAIN SHUTOFF VALVE, DO NOT SHUT OFF SWITCH, AND CONTACT YOUR HEATING CONTRACTOR, GAS COMPANY, OR FACTORY REPRESENTATIVE.

5. You MUST check flame monitoring control (ignition system safety shutoff device).
 - a. Close gas cock with burner operating.
 - b. In 3 seconds, FLAME indicator light will go out and blower will continue to run on post purge cycle. Two additional attempts to light will follow including pre-purge, igniter on, valve/flame on and post purge. (Ignition will not occur-gas off).
 - c. Open gas cock. Switch unit "OFF" and then "ON" again. Burner should start after about 45 seconds. It is recommended that the unit be checked with a standard CO² or O² tester. Insert tester probe at least 6" into exhaust pipe through outside vent terminal. Readings should be:

CO₂ - 8% to 8.5% (nat. gas) 9% to 9.8% (LP gas)
 O₂ - 7% to 4½%

6. Check Burner Input (other equipment off)
 - a. Measure the time, in seconds, it takes to use one cubic foot of gas.
 - b. Divide the number of seconds into 3,600.
 - c. Multiply the result by the heating value of the gas to obtain BTU/HR input.

Example: If it takes 36 seconds to use one cubic foot of gas and the heating value of the gas is 1,000 BTU/CU FT, (approx. natural gas value).

$$\text{INPUT} = 3,600/36 \times 1,000 = 100,000 \text{ BTU/HR}$$

Input Ranges

- | | | |
|-------------|---|---------------------------|
| H(W)-M2-130 | - | 127,400 TO 132,600 BTU/HR |
| H(W)-M2-100 | - | 98,000 TO 102,000 BTU/HR |
| H(W)-M2-60 | - | 58,800 TO 61,200 BTU/HR |

Because of the altitude and other minor variations, it is possible the input will not fall within this range and the gas orifice must be replaced. See chart in an orifice kit.

CHECK LIMIT CONTROL OPERATION

OPERATING AND LOW LIMIT CONTROL HW-M2

- a. When water temperature reaches low limit set point (180°F) with no call for heat, Heatmaker will shut down.
- b. Turn up the room thermostat. Boiler pump (inside jacket) will now run.
- c. If water temperature is below operating control cut out temperature (210°F) burner will fire.
- d. When operating control cut-out temperature is reached (210°F) burner will go off, blower will post purge for 30 seconds and the boiler pump and system circulator will continue to operate until room thermostat is satisfied.
- e. When water temperature drops below low limit cut-in temperature (150°F) and there is a continued call for heat, the system circulator will go off. The boiler pump will continue to operate and the burner will remain on. When low limit cut-out temperature is reached (180°F) the system circulator will come on.

OPERATING CONTROL H-M2

- a. Burner will run until operating control cut-out temperature (185°F) is reached.
- b. When Operating Control cut-out temperature is reached, burner will go off and boiler pump will continue to run and blower will post purge for 30 seconds.
- c. When temperature reaches Operating Control cut-in temperature (160°F), burner will start and continue to run until a call for heat is satisfied or Operating Control cut-out temperature is reached again.

SAFETY LIMIT OPERATION H(W)-M2

If boiler water temperature exceeds operating control cut-out temperature for any reason, the safety limit will interrupt power to the gas valve at approximately 215°F, the blower will post purge for 30 seconds and the unit will shut down. The safety limit will reset at 195°F.

Note: temperature of limit operations are all approximate; allow for gauge and tolerance variations.

STACK SWITCH OPERATION H(W)-M2

If, for any reason, the combustion air blower fails to provide adequate air flow, or if the flue is blocked so as to prevent sufficient air flow for proper combustion, the contacts of the stack switch will open and the unit will shut down. After 5 minutes, purge light will flash.

Close all covers. Reset room thermostats and place these instructions in a place convenient to the unit.

Please be sure that the warranty card is mailed to TRIANCO-HEATMAKER, INC. by either you or the property owner.

COMMON VENT TEST

Required only if Heatmaker is not being chimney connected. At the time of removal of an existing boiler, the following steps shall be followed with each appliance remaining connected to the common venting system placed in operation, while the other appliances remaining connected to the common venting system are not in operation.

- a. Seal any unused opening in the common venting system.
- b. Visually inspect the venting system for proper size and horizontal pitch and determine there is no blockage or restriction, leakage, corrosion and other deficiencies which could cause an unsafe condition.
- c. Insofar as is practical, close all building doors and windows and all doors between the space in which the appliances remaining connected to the common venting system are located and other spaces of the building. Turn on clothes dryers and any appliance not connected to the common venting system. Turn on any exhaust fans, such as range hoods and bathroom exhausts, so they will operate at maximum speed. Do not operate a summer exhaust fan. Close fireplace dampers.
- d. Place in operation the appliance being inspected. Follow the lighting instructions. Adjust thermostat so appliance will operate continuously.
- e. Test for spillage at the draft hood relief opening after 5 minutes of main burner operation. Use the flame of a match or candle, or smoke from a cigarette, cigar or pipe.
- f. After it has been determined that each appliance remaining connected to the common venting system properly vents, when tested as outlined above, return doors, windows, exhaust fans, fireplace dampers and any other gas burning appliance to their previous conditions of use.
- g. Any improper operation of the common venting system should be corrected so the installation conforms with the
 - 1). National Fuel Gas Code, ANSI Z223.1 latest edition.
 - 2). Can / CGA - B149

When re-sizing any portion of the common venting system, the common venting system should be re-sized to approach the minimum size as determined using the appropriate tables in Part 11 in the National Fuel Gas Code, ANSI Z223.1-latest edition.

LIGHTING AND SHUTDOWN INSTRUCTIONS

A. LIGHTING

- 1. Ensure that boiler is filled with water, air is bled from boiler coil and that boiler water pressure is at a minimum of 12 psi.
- 2. Open main gas cock.
- 3. Open gas cock on gas valve.
- 4. Turn "ON" disconnect switch (on right side of unit).
- 5. After 45 seconds, ignition will occur (if there is a call for heat).

B. SHUTDOWN

- 1. Turn "OFF" disconnect switch.
- 2. Close gas cock on gas valve.
- 3. Close main gas cock.

MAINTENANCE

OWNER CARE AND MAINTENANCE

- 1. Inspect venting system - Annually remove screws on vent terminal and remove terminal. Inspect interior with flashlight.
- 2. General Housekeeping - Keep boiler area clear and free from combustible materials, gasoline and other flammable vapors and liquids.
Keep boiler jacket louvers clear for proper cooling of internal components.
Do not obstruct boiler room ventilation screens or grills.

SERVICE MAINTENANCE

- Cleaning Heat Exchanger to be done by qualified service person.
- 1. Turn off electric and gas supplies and remove the jacket.
 - 2. Remove the vent assembly and top cover.
 - 3. Remove the top half of the combustion chamber by removing the three screws and nuts that clamp the top half to the bottom half, the clamp on the induction tube and the 1/8" diameter balance lines.
 - 4. Remove the top insulator cap by spreading the retainer.
 - 5. Remove the igniter - to avoid damage during cleaning.
 - 6. Clean the finned tubing with a wire brush and vacuum all loose material from the combustion chamber. Wipe flameholder (burner) with a clean dry rag.
 - 7. Replace all parts in the reverse order in which they were removed.
 - 8. Restart the unit as indicated by the operating instructions plate.

ADJUSTING BURNER / INPUT

The HeatMaker burner system is a pre-mixed, forced combustion system. Outside air is drawn through the air orifice (located in the air induction system) and mixed with the gas drawn in downstream of the air orifice. The gas is metered through an orifice located in the gas orifice union. All the air required for complete combustion comes into the system in this manner.

Adjusting the input is limited to changing the gas orifice to achieve the proper input. The air orifice cannot be altered and the gas valve pressure setting cannot be changed.

Before changing the gas orifice to correct input, service representatives should make the following checks:

1. The pressure on the inlet side of the gas valve is between 4" and 13" water column.

2. The pressure on the outlet side (manifold) of the gas valve and "T" above air orifice is between negative .05" and negative .35" water column with the unit operating.

To increase the input, install larger diameter gas orifice. Each size will change the input approximately 5 C. F. H. Once the correct input has been achieved, the burner should be checked with an oxygen (O₂) or carbon dioxide (CO₂) gas analyzer.

The unit should be in operation 5 minutes before adjusting input or taking CO₂ or O₂ readings. This time will allow for pre-heating of the intake air.

Insert the probe of the O₂ or CO₂ tester at least 6" into the vent through the vent terminal. If CO₂ is being measured, the readings should be between 8.0 and 8.5 for natural gas and 9.0 and 9.8% for propane. If O₂ is being measured, the readings should be between 7 and 6.

Measuring CO₂ *

When operating on natural gas, readings below 8.0 generally indicate a lean mixture (not enough gas). Readings above 9.25 generally indicate a rich mixture (too much gas). Inputs should be increased or decreased to correct lean or rich mixtures.

NOTE: If the mixture is very rich (not enough air for complete combustion), it is possible to get low readings on a CO₂ analyzer. This situation does not occur often but it can be detected if reading continues to go lower as the input is increased. If this condition is suspected, a CO test should be taken at the vent outlet. Inputs must be reduced to correct high CO reading and to bring CO₂ readings to proper levels.

* The following numbers apply to natural gas only. The range of operation for LP is 9.0 to 9.8.

Measuring O₂

Readings above 7% indicate a lean mixture (not enough gas). Readings below 4½% indicate a rich mixture. Input should be increased or decreased to correct lean or rich mixtures.

CLEANING COMBUSTION CHAMBER COIL

1. Turn off electric and gas supplies and remove the jacket.
2. Remove the vent assembly and top cover.
3. Remove the top half of the combustion chamber by removing the 3 screws and nuts that clamp the top half to the bottom half, the clamp on the air orifice hose and the two clear plastic lines connected to the "T" on the air induction elbow.
4. Remove the top insulator cap by spreading the retainer.
5. Remove the igniter.
6. Clean the finned tubing with a wire brush and vacuum all loose material from the combustion chamber.
7. Replace all parts in the reverse order in which they were removed.
8. Restart the unit as indicated by the lighting instruction label.

UNIT PUMP

The unit pump operates whenever there is a call for heat or hot water.

It is a wetted-rotor type pump and should always be filled with water when it is operating so that it will cool properly.

If a pump change is required for any reason, valve off the boiler and drain approximately 1 or 2 gallons of water from the unit. Turn off the main disconnect switch and unplug the pump wires, remove the pump motor. **The pump housing need not be removed.** The replacement pump motor should be installed in the reverse order from which the old pump motor was removed. After filling the system be sure to bleed the coil.

NOTE: If the pump motor is not defective the pump cartridge alone may be changed (Taco Pumps Only).

GAS VALVE

The gas valve is a solenoid operated, negative pressure regulated valve. The outlet pressure is regulated at minus 0.2 inches w.c. It is designed to operate with supply pressures of 4-13 inches w.c. Within that range of supply pressures, the regulated discharge pressure may vary from minus .05 to minus .35 inches w.c. The regulator is not adjustable and the effect of this variation in discharge pressure is not significant. Because of the fixed regulator setting, gas flow must be adjusted by changing the gas orifice.

To remove the gas valve, shut off 120 volt power and the master gas cock in gas line, loosen the nut on the gas orifice union and remove the orifice union plus piping to the gas valve. Disconnect the wires from the gas valve. The valve may now be unscrewed from the inlet piping. It may be necessary to deflect the inlet piping somewhat in order to clear the boiler jacket. After the valve has been removed, replace with a new valve in the reverse order in which the old valve was removed. Do not over tighten the fittings into the valve body as this may cause damage to the valve.

NOTE: When fueled by LP gas, HeatMakers perform best with 9-10 in. W.C. supply pressure. If no other appliances are being supplied by the LP supply set the low pressure regulator to 9-10 in. W.C.

SAFETY LIMIT SWITCH

The Safety Limit Switch has a fixed set point at 215°F. It will reset automatically.

To replace the switch, shut off the 120 volt power and valve off the boiler, drain 1 or 2 gallons of water from the boiler and remove the nut which holds the safety limit bulb in the boiler discharge fitting. Remove the bulb from the fitting and remove the 2 screws which hold the switch assembly to the electrical control box. Disconnect the 2 wires from the quick connects at switch and remove the safety limit assembly. To replace, perform the same operations in reverse. Push the sensing bulb as far into the fitting as possible before tightening sealing nut. No more than 1/2" of sensing bulb should be visible after installation. Fill the boiler and be sure to bleed the coil at the coil bleed petcock. Turn on disconnect switch and check boiler operation.

OPERATING CONTROL

The Operating Control maintains boiler discharge temperature between 170-210°F during the space heating cycle. It has a fixed set point of 210°F (HW-M2 Series only) and a differential of 40°F, therefore, its contacts open at 210°F and they reclose at 170°F. If replacement is necessary, shut off the 120 volt power and disconnect the wires to the sensor. Valve off and drain 1 or 2 gallons of water from the boiler and remove sensor. Install new sensor, refill boiler and bleed coil at coil bleed petcock. Check boiler operation after installation of new Operating Control. The Operating Control on the H(P)-M2 series has a fixed set point of 185°F. Its contacts open at 185°F and they reclose at 160°F.

IGNITER

The igniter is a "glow bar" type silicon carbide unit. It is energized whenever there is a call for heat and the red "IGNITER" light on the boiler control is lit. After the igniter is switched off and the boiler continues to run, the igniter functions as a flame sensor for the boiler control.

If the ignitor fails and must be replaced, always install a new igniter gasket with the replacement igniter.

CAUTION: Ignitor gets hot.

PRESSURE DIFFERENTIAL SWITCH

The Pressure Differential Switch is a normally open single pole switch which is designed to detect pump operation and water flow. To replace, turn off electrical power & boiler feed water. Valve off and drain 1 or 2 gallons of water from the boiler, unplug wires from the switch and remove switch. Install new switch in reverse order. Refill boiler and bleed air from the coil bleed petcock. Turn on electrical power and recycle system.

TRANSFORMER

The control transformer accepts 120 VAC power and provides 40 VA of 24 VAC power for the boiler control only. It is not capable of supplying control power for external devices such as zone valves. They must have their own separate power supply.

LOW LIMIT (HW-M2 Series Only)

The Heatmaker Mark 2 may be equipped with a strap-on Low Limit. The Low Limit control performs two functions. It controls the temperature of the water in the transfer tank and it prevents the house circulator from operating when insufficient tank water temperature causes the domestic hot water delivery temperature to drop below 140°F. The Low Limit Control has a fixed differential of 15°F and is set to turn the burner on at 140°F tank water temperature and to turn it off when the sensor reaches 155°F. Because of the thermal lag in the sensor, the tank water temperature will reach about 180°F before the burner actually is turned off. The boiler temperature may reach operating temperature due to this thermal lag.

If replacement is necessary, shut off the 120 volt power. Simply remove and attach wire for wire. Clamp the new Low Limit to the hot outlet pipe as close to the domestic exchanger plate as possible and cover area with tank insulation blanket. Return boiler to service.

BLOWER

The Combustion Air Blower is a high head centrifugal blower. It is designed to provide about 2" w.c. of suction at 30 CFM. This performance is necessary to operate the gas valve reliably, to overcome induction system friction losses and to eliminate any sensitivity to wind striking the vent terminal. It is powered by a 120 volt motor which draws about 1.3 amps at rated load. It is powered by the integrated boiler control whenever there is a call for heat and 30 seconds thereafter. If a blower change is required, turn off the 120 volt power and unplug the power wires from the blower motor. Remove the three nuts from the blower discharge flange and the four nuts from the blower inlet flange. The blower may now be deflected enough to permit its removal. Install the new blower using new gaskets, in the reverse order from which the old blower was removed. The four inlet flange nuts, however, should only be finger tight initially and then tightened with a wrench after all other operations have been completed. The combustion should be checked for correct air-fuel ratio whenever the blower is replaced (see Burner Adjustment).

PRIORITY RELAY - R1 (HW-M2 Series Only)

The Priority Relay is a normally open single pole relay which accepts a 24 VAC signal from the low limit aquastat and the T-T wires to provide 120 VAC power to the system circulator when the tank temperature remains above 150°F.

BOILER CONTROL

The Integrated Boiler Control Module controls the combustion process, the gas valve, the igniter, the blower, the unit pump and the system circulator. It provides blower prepurge as well as burner flame sensing. When replacing the boiler control turn off disconnect switch and press in tabs on each end of plugs to remove from control. All plugs are color coded and it is not possible to miswire the control.

STACK SWITCH

The Stack Switch is a normally open single pole switch which is operated by the pressure difference across the air orifice. It is set to close when a static pressure difference of 1 in. w.c. is generated by the combustion air blower. Its function is to prove airflow and to inhibit burner operation in the event of flue or chimney stoppage. The switch is wired directly to the boiler control. It is located on the inside of the jacket back panel adjacent to the boiler bracket.

TRANSFER TANK AND DOMESTIC HOT WATER COIL (HW-M2 Series Only)

The transfer tank contains approximately 20 gallons of boiler water. It functions as an energy storage vessel to reduce boiler cycling on small output heating zones and to provide heat for domestic hot water through the domestic hot water (DHW) coil immersed in it. The DHW coil may be removed from the tank if either tank or the DHW coil must be replaced. The coil is secured to the tank with (6) -3/8" - 16 bolts which are replaceable if they are broken or stripped.

THERMOSTATIC UNION (H(P)-M2-Series Boilers Only)

The thermostatic union is a 1¼" NPTF union which has a thermostatic element on the inside. The element has two small bypass holes to allow some water to flow into the system when the element is closed. When the boiler first starts and cold system water is returning, the element is closed and boiler water is recirculated back to the return until the supply water reaches 160°F and the element opens. To replace the element shut off and drain the section of the system that the thermostatic union is installed in. Open the union and replace the element with a new one. The element should be installed so that its spring and actuator are on the **system** side. Close union, open valves, refill and bleed system, bleed coil at coil bleed petcock and restart boiler.

TIME DELAY RELAY (TDR) (H(P)-M2-Series boilers only)

The Time Delay Relay controls the unit pump and keeps it operating for approximately one minute after the blower post purge stops. Control voltage on the TDR is 24 volts from the limit circuit. The contacts to supply pump power are 120 VAC. They delay on open one minute after the 24 volt control voltage is interrupted. Turn off disconnect switch before changing TDR.

DHW COIL REPLACEMENT

Shut off boiler feed water, domestic water supply to coil and electrical power to boiler. Valve off system and drain the water from the tank. Disconnect boiler discharge union from coil fitting, remove relief valve discharge piping and cut the horizontal hot and cold water pipes about 6 inches away from plate. Disconnect and remove low limit sensor. Remove the six coil retaining nuts and take out coil. Remove the old coil gasket and clean gasket sealing surface on tank. Remove the pressure relief valve from old coil and install in new coil assembly with thread sealing tape or pipe joint compound. Install new gasket in recess on tank (if it doesn't fit snugly in tank recess remove it and stretch it). Place new coil in tank and screw on coil retaining nuts. Tighten nuts evenly to seat gasket properly. Do not over tighten. Make up boiler discharge union, fill boiler and check around gasket for leaks. If the coil plate is leak tight make up hot and cold water pipes with slip couplings and reassemble relief valve discharge piping. Connect and reinstall low limit sensor. Turn on domestic water supply and electrical power. Bleed air from coil bleed petcock and recycle boiler. Boiler fill pressure is 12 PSI minimum.

TANK REPLACEMENT

The tank can be replaced by disconnecting the DHW coil as explained above and unbolting the lower pump flange bolts. Access to the tank is possible by removing the jacket lower front panel. This is done by removing the screws that hold the panel at the base and by cutting an aluminum pop rivet on each side at the top approximately 2 inches down. These rivets hold the lower front panel to the jacket back. A flat bladed tool like a putty knife is ideal for this purpose. Drive the blade down from the top in the crease between the jacket back and the lower front panel. This will cut the rivets. Remove the four screws that hold the electrical box and move it aside. The lower front panel may now be lifted up above the base and removed. When the boiler is shipped from the factory there are shipping bolts which hold the tank and the base together. The installer was instructed to remove these bolts before installing the boiler. If this was done nothing will be holding the tank in place at this time except the hydronic piping at the rear of the appliance. Remove the supply and return connections and remove the tank. Installation of the new tank is done in the reverse order. If the tank alone is being replaced it is easier to remove tank and coil together and change the coil from the old tank to the new one when both are free of the jacket.

DELAYED IGNITION

Possible Causes - Time of occurrence

- a. High lockups on LP - occurs on start-up.
- b. Gas valve regulation problem - occurs on start-up.
- c. Defective burner (flameholder) - occurs primarily on burner shutdown
- d. Natural gas orifice in LP unit - occurs on startup

a). High lock up pressures on LP fuel systems are the most common cause of delayed ignitions on Heatmaker boilers. The high LP supply pressure results from improper second stage regulator selection or a faulty regulator.

It can be detected by measuring the gas supply pressure to the unit at the inlet pressure tap on the gas valve. Use a water manometer or pressure gage with a scale reading of at least 25 in. W.C. or 15 oz/in². Install the pressure tap in the 1/8" NPTF plugged port located above the gas inlet port on the gas valve. The gas supply to the boiler must be shut off before making this connection. The Heatmaker boiler is designed to operate with supply pressures of 4-13 in. W.C. (2.3 - 7.5 oz/in²). If supply pressure exceeds 13 in. W.C. (7.5 oz/in²) with the boiler not operating it is likely that this is the cause of the delayed ignition. Lock up pressures must be measured when the boiler is not operating and preferably immediately after boiler shutdown.

b). Gas valve regulation problems can also cause delayed ignitions. To detect gas valve regulation problems it is necessary to have an inclined manometer or a Magnehelic pressure gage. The normal gas valve regulator setting is - 0.2 in. W.C. It is measured between the 1/8" NPTF plugged port marked PRESS TAP on the gas valve and the barbed fitting above the air orifice coupling.

The pressure will be about -2.5 IN. W.C. when the blower is running (prepurge) before the gas valve opens. When the gas valve is energized and the solenoid opens the pressure should rise to - 0.2 IN. W.C. This should happen smoothly without allowing the pressure to go positive (above 0 IN. W.C.). If the pressure spikes positive when the solenoid opens then the gas valve regulator is faulty and may be the cause of the delayed ignition (assuming inlet tested OK).

c). A defective burner (flameholder) can cause a delayed ignition however not often. If the gas supply pressure and the gas valve are functioning properly and the air and gas orifices are correct the burner should be inspected. To inspect, remove the blower and the burner will drop out of the bottom of the chamber. There should be no perforations other than the punched holes. When replacing the burner the insulating pad must be on the top of it. If none was on the burner when it was removed check to see if it fell off during burner removal and has stayed in the combustion chamber. Never leave an insulating pad lying in the combustion chamber as this can cause burner overheating and perforation.

NOISY OPERATION

There are two principal sources of noisy operation:

- a. Combustion - high pitched noise - whistle or hoot
- b. Boiling (kettling) - lower frequency noise which varies with temperature - moan.

a). Combustion noise occurs at any boiler discharge temperature and is heard the loudest at the flue outlet (especially on units with side wall venting). There are two basic causes for the noise, rich mixture and cross contamination. To check for a rich mixture, it will be necessary to measure the percent O² or CO² in the flue products. O² readings lower than 4½ % or CO² readings higher than 9¼% (natural gas) and 10.8% (LP) will often cause combustion noise. To eliminate the noise it will be necessary to install a smaller gas orifice so that the O² will rise above 4½% or the CO² will drop to 8½% (natural) or 9½% (LP).

Sometimes the readings are influenced by cross contamination and a check for cross contamination should be done before changing orifices if it is suspected. A strong smell from the flue products is generally an indication. Check for cross contamination using the procedure listed in the index. If there is no cross contamination, reorificing should be done.

b). Boiling (kettling) may occur at boiler discharge temperatures from 170°F to 210°F. The temperature at which it starts will vary from one installation to another. The primary cause of the problem is poor heat transfer on the inside of the boiler coil. This may be caused by foaming of antifreeze in the system or scaling from the boiler water if no antifreeze is present.

There are many manufacturers of plumbing and boiler antifreezes. Plumbing antifreezes should never be used in a boiler system because they have no antifoamants in them. Not all boiler antifreezes have an effective antifoamant either so the noise may exist with boiler antifreezes also.

The cure for the boiling noise is the same regardless of the cause. However, if antifreeze in the system is suspected of being the cause, the concentration and type should be investigated before attempting to eliminate the noise. The most effective means of cleaning the combustion coil utilizes the siphon cleaning method. Instructions for this method may be obtained from Trianco as Service Bulletin #SB-9701. Concentrations of antifreeze should be kept as low as possible because antifreeze will reduce heat transfer and efficiency.

Many times it is difficult to determine if the noise is combustion or boiling related. The best clue is when in the cycle the noise appears and if its frequency changes with boiler discharge temperature. Combustion noises always have the same frequency, however, their volume may change from the time that the burner first fires to the time that it shuts off. Boiling noises have a frequency that varies with boiler discharge temperature and sometimes they will disappear completely at higher temperatures just before the boiler goes off on limit. Vibration of the boiler pressure gage needle may also occur with boiling noises.

INSUFFICIENT HOT WATER (HW - M2 - Series Only)

Possible Cause:

- a. No Flow Restrictor
 - b. Low limit Failure
 - c. Incorrect Wiring of System Circulator
 - d. No Flow Check in System Supply
 - e. Coil Contamination
- a). The most common cause for insufficient hot water complaints results from failure to install a flow restrictor. If there is no flow restrictor water passes through the coil at a greater volume than the boiler output is capable of heating to the desired temperature rise.
- b). Failure of the low limit to operate within its normal calibration points will have the same effect as incorrect system circulator wiring.
- c). Incorrect wiring for the system circulator can also cause the problem. If the blue wire in the field wiring box is not used to control the circulator or circulators then the low limit cannot prevent boiler water temperature from dropping to a point that is insufficient to provide enough heat for the domestic hot water coil. The blue wire interrupts power to the system circulator through the priority relay R-1. R-1 is controlled by the low limit which should limit minimum tank temperature to 140°F.
- d). Flow checks in single zone systems and multizone systems with zone circulators prevent gravity circulation of heated boiler water from the transfer tank. If no flow check exists or if an existing flow check is left in the manual (open) position, heat leaves the bottom of the tank by gravity circulation. Because of stratification in the tank when the pump is off, the water around the low limit sensor will remain hot and the boiler will not replace the heat that is lost. When domestic hot water is turned on there will be a short draw of domestic hot water and then, when the unit pump comes on to start the boiler, the cold water in the bottom of the tank will be mixed with the hot water at the top and mix temperature will be too low to provide adequate domestic hot water and it will turn cold. If this is the suspected cause feel the temperature of the piping after the flow check when the heating system has not been calling for awhile. If the piping is hot, there is flow past the flow check which may be causing the problem.
- e). Coil scaling may occur in some areas of the country where there are high concentrations of minerals in the water. These minerals may cause fouling of the domestic hot water coil over an extended period of time (lime build up) or they may in rare instances cause a problem in less than a year of operation. The minerals which react quickly (mostly magnesium) in well systems cause a slime on the inside of the coil which prevents adequate heat transfer. These minerals must be filtered out by a special incoming water filter or inhibited to protect the coil and also to provide acceptable water quality. The minerals contained in public water systems which accumulate in the coil over long periods of time may be removed when necessary by flushing the coil with cleaner such as "Unlime" or "Sizzle". These products are also effective in cleaning a coil that is fouled by magnesium.

HIGH GAS CONSUMPTION

SEE ALSO CROSS CONTAMINATION

Improper burner operation caused by incorrect air/fuel ratio (CO₂ or O₂ out of the specified range) will cause high gas consumption. It is most noticeable on LP fired units with low CO₂ or high O₂, however, units operating on LP or natural gas with incorrect air/fuel ratios will not provide their best efficiency. If no combustion analyzing equipment (CO₂ or O₂) is available an indication of the air/fuel ratio can be gotten by briefly sniffing the flue gases. When running properly the Heat Maker's flue gases should have little smell. If they have a strong piercing smell the gas orifice is probably too small. Do not attempt to do reorificing without an O₂ or CO₂ kit.

SHORT CYCLING

(H-M2, HP-M2 Series Only)

SEE ALSO CROSS CONTAMINATION

Possible Causes:

- a. No system circulator - low system water flow
 - b. Small zones - high zone return temperature
- a). The most common causes of short cycling of HeatMaker H(P)-M2- Series and other low mass boilers is insufficient hydronic system water flow or small zones. With HeatMakers this is sometimes caused by the installer's failure to install a system circulator as required in the Installation and Operating Instructions.
- The result of low flow is very rapid temperature rise in the boiler. Sometimes the rise is so fast that the operating control will not operate before the safety limit operates. Boiler will reset following cool down of safety limit thermo element.
- b). Another cause of short cycling is a result of system design. If one zone in a zoned system has a very small output, the boiler will only be on for a short time (when that zone is operating alone) before the return water comes back to the boiler at a temperature which will cause the operating control contacts to open. If this situation causes very rapid cycling it may be necessary to only operate the small output zone when another zone is calling. This can be done most simply (on systems using zone valves) by disconnecting the end switch wire on the small output zone one so that the boiler will not be started unless another zone is calling. This approach eliminates the need for time consuming repiping. If the on cycles are at least 1½ minutes long then the short cycling will not be a problem.

CROSS CONTAMINATION AND COMBUSTION RELATED SHORT CYCLING

UNITS INSTALLED WITH QUICK VENT

Boiler short cycling, nuisance lockouts and objectionable flue gas odors, may be caused by leakage of flue products into the combustion air stream. This results from poorly sealed joints in the inner (3") pipe. The symptom of this problem is continual restarts without a lockout occurring. The "VALVE/FLAME" lite will be on for only a short time (but more than 6 seconds) before the post purge starts. This condition is generally seen on new installations; however, it is possible that a poorly assembled flue pipe could come apart and cause the same effect. Cross contamination can best be detected with a CO₂ analyzer (Bacharach® kit for example). Remove the stack switch tube from the "tee" fitting above the air orifice and connect the sampling tube of the analyzer to the "tee". Run boiler and check CO₂. If there is any measurable CO₂, cross contamination exists somewhere in the flue system. If the boiler will not operate long enough to get a CO₂ sample it is possible to check for cross contamination in another way. Loosen the top clamp on the air duct coupling and remove the gas balance line from the "Tee fitting". Lift up the air induction elbow and twist it to the side so that air from the space around the boiler can be drawn into the air duct coupling (do not disturb the air orifice in the coupling). Cover the air induction elbow with your hand or plug it with a rag and restart the boiler. If no short cycling occurs there is a leak in the 3" flue pipe which must be corrected. Do not leave the boiler operating in this manner. Reassemble the air duct after removing plug (rag) and connect the balance line and stack switch tubes. Disassemble flue and fix leak.

LOCK OUTS

Integrated Boiler Control Lock Outs - Possible Causes

- a. Cross Contamination
 - b. Moisture in Combustion Chamber
 - c. Gas Valve Malfunction
 - d. Poor combustion
 - e. Boiler control malfunction
 - f. Control contact failure
 - 1). Stack Switch
 - 2). Operating Control
 - g. Failure of air source
 - h. Ignitor failure
- a). If cross contamination is suspected see "Cross Contamination" and check for it. One percent CO₂ in the air duct can cause nuisance lockouts.
- b). Moisture in the combustion chamber will also cause lock outs by weakening the flame signal to the boiler control. It should be suspected if the boiler temperature does not rise above 160°F during long periods of operation. This condition can be caused by a defective thermostat in the thermostatic union of H(P)-M2-series boilers (or the omission of the thermostatic union at installation) or an improperly wired system circulator on HW-M2-series boilers. On sidewall vented units moisture can get into the combustion chamber from a flue pipe that is pitched incorrectly (back toward the boiler without a condensate trap). Quick Vented systems should always pitch down from the boiler.
- c). A defective gas valve (one that doesn't always open properly) can cause a nuisance lockout however occurrences of this are rare.
- d). A more common cause of nuisance lockouts is poor combustion. If there is an odor in the flue gases, this should be suspected. Check CO₂ or O₂ to determine if combustion is within limits. Poor combustion causes a weak flame signal to the burner control and lock outs may result.
- e). If combustion is within limits and none of the causes mentioned above seems to be the cause of the lockout it is possible that the boiler control may be defective.

SEQUENCE OF OPERATION

On a call for heat from the room thermostat on H(W)-M2 series boilers (or the low limit on the HW-M2 series), the pump operates and the boiler control is energized through the operating control, pressure switch and the safety limit. It checks to ensure that the stack switch contacts are open and then energizes the blower. The blower starts and the air pressure increases until the stack switch contacts close and the red **"PURGE"** light lights. The pump and blower continue to run and for 15 seconds the red **"PURGE"** light stays on. Following that the red **"PURGE"** light goes out, the red **"igniter"** light lights and the igniter heats for 20 seconds. At the end of the 20 seconds the red **"VALVE\FLAME"** light is lit and the gas valve is energized. For 2 seconds the valve and igniter are energized and burner will ignite. Following this the igniter is deenergized and the red **"IGNITER"** light goes out and the pump and blower continue to run and the burner operates under the supervision of the boiler control. If for any reason the full sequence is completed and the burner doesn't ignite, the sequence will be repeated after a blower "on" time of 45 seconds (30 seconds post purge and 15 seconds prepurge for the next cycle). During this part of the sequence the igniter remains on for 30 seconds and the balance of the sequence is unchanged. If no ignition occurs again a third cycle will follow with the same sequence as the second. After the third "trial for ignition" if the burner does not ignite the system will "lock out" and reset can only be accomplished by momentarily switching the power off. At the end of a heating cycle (either space heating or domestic water heating) after the gas valve is deenergized the blower will continue to run for a 30 second post purge. If normal burner operation during a heating cycle is interrupted by any of the limit controls the unit pump will continue to run and the blower will continue to operate for a 30 second post purge.

TROUBLE SHOOTING (DETAILED FLOW CHARTS ON PAGES 26-32).

If the burner "locks out" for any reason the cause will be indicated by one of the following lights.

CODE

- GREEN "POWER"** No light - no power *or* Light on - see trouble shooting section.
- RED "PURGE"** Light flashing - blower or stack switch failure or possible flue blockage.
- RED "VALVE\FLAME"** Light flashing - valve, igniter or flame sense failure (combustion related problem).

NOTE: If the stack switch contacts are closed for any reason when the blower isn't operating a sequence will not occur and after 45 seconds the control will "lock out" and the **"PURGE"** light will flash. If the stack switch contacts are open and do not close during purge period, after 5 minutes the control will lock out and the **"PURGE"** light will flash.

If the boiler does not operate, the green "power" light is on and no indicator lights are flashing, check for an open pressure switch, low limit switch (on HW-M2 series), operating control or safety limit switch on either series. For additional troubleshooting information refer to the trouble shooting flow charts on the pages that follow.

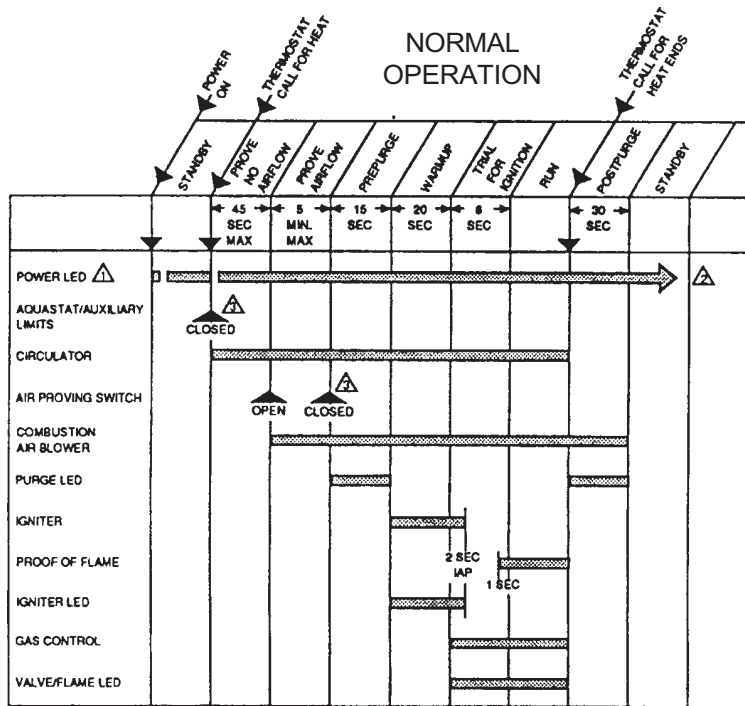

- POWER LED BLINKS ONCE WHEN 24V POWER IS APPLIED AND WHEN THERMOSTAT CALLS FOR HEAT.
- ON AS LONG AS CONTROL IS POWERED AND OPERATING PROPERLY
- IF EITHER SWITCH OPENS DURING THE RUN CYCLE, BURNER WILL STOP, FOLLOWED BY POSTPURGE. CIRCULATOR WILL RUN AS LONG AS THERMOSTAT IS CALLING FOR HEAT. BURNER IGNITION SEQUENCE WILL RESTART IF SWITCH CLOSES.

M 727

GENERAL TROUBLE SHOOTING

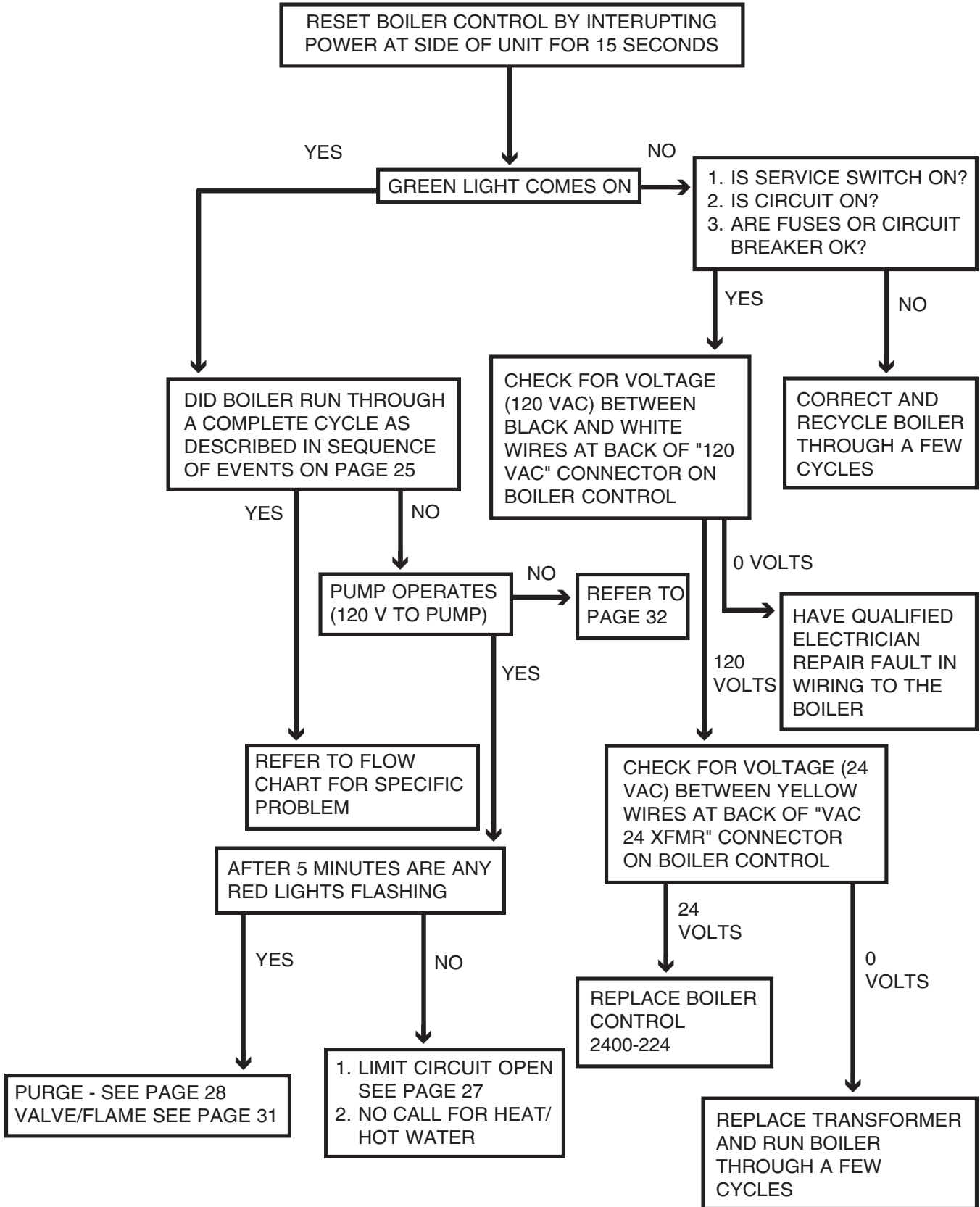

* POOR SWITCH CONTACT ON RELAYS, ZONE VALVES, OR THERMOSTATS CAN CAUSE A FLASHING GREEN LIGHT ON JOHNSON CONTROLS G856DBG - 5201.

TESTING LIMIT CIRCUIT (YOU MUST COMPLETE PAGE 26 FIRST)

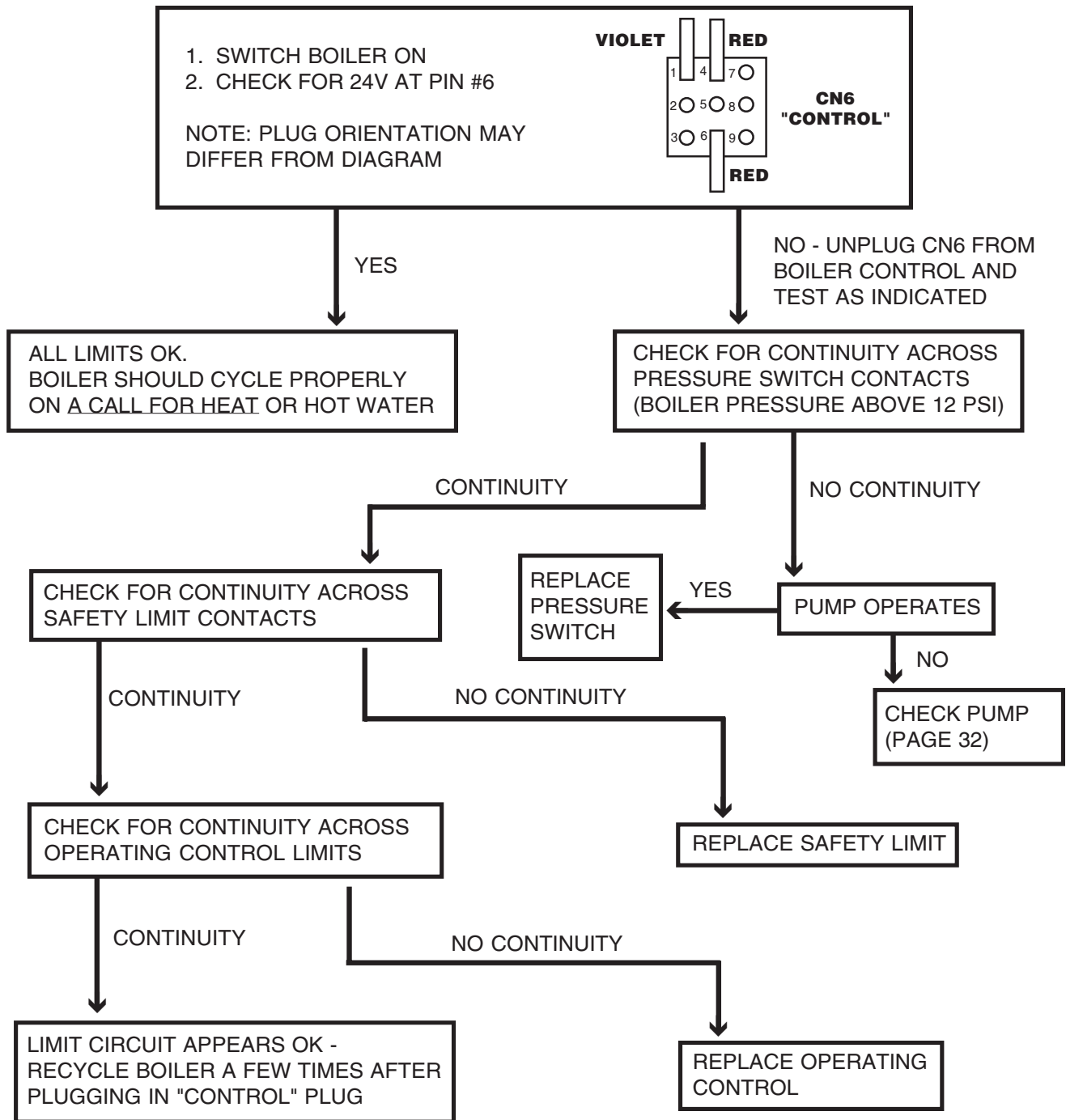

NOTE: AFTER COMPLETING LIMIT CIRCUIT TESTING, RECYCLE BOILER A FEW TIMES. IF BOILER DOES NOT RECYCLE CONNECT A JUMPER TEMPORARILY BETWEEN THE RED WIRES. IF BOILER STARTS REMOVE JUMPER AND TEMPORARILY JUMP EACH SAFETY CONTROL UNTIL THE DEFECTIVE CONTROL IS LOCATED. NEVER LEAVE A SAFETY CONTROL JUMPED.

RED "PURGE" LIGHT FLASHING (YOU MUST COMPLETE PAGE 26 FIRST)

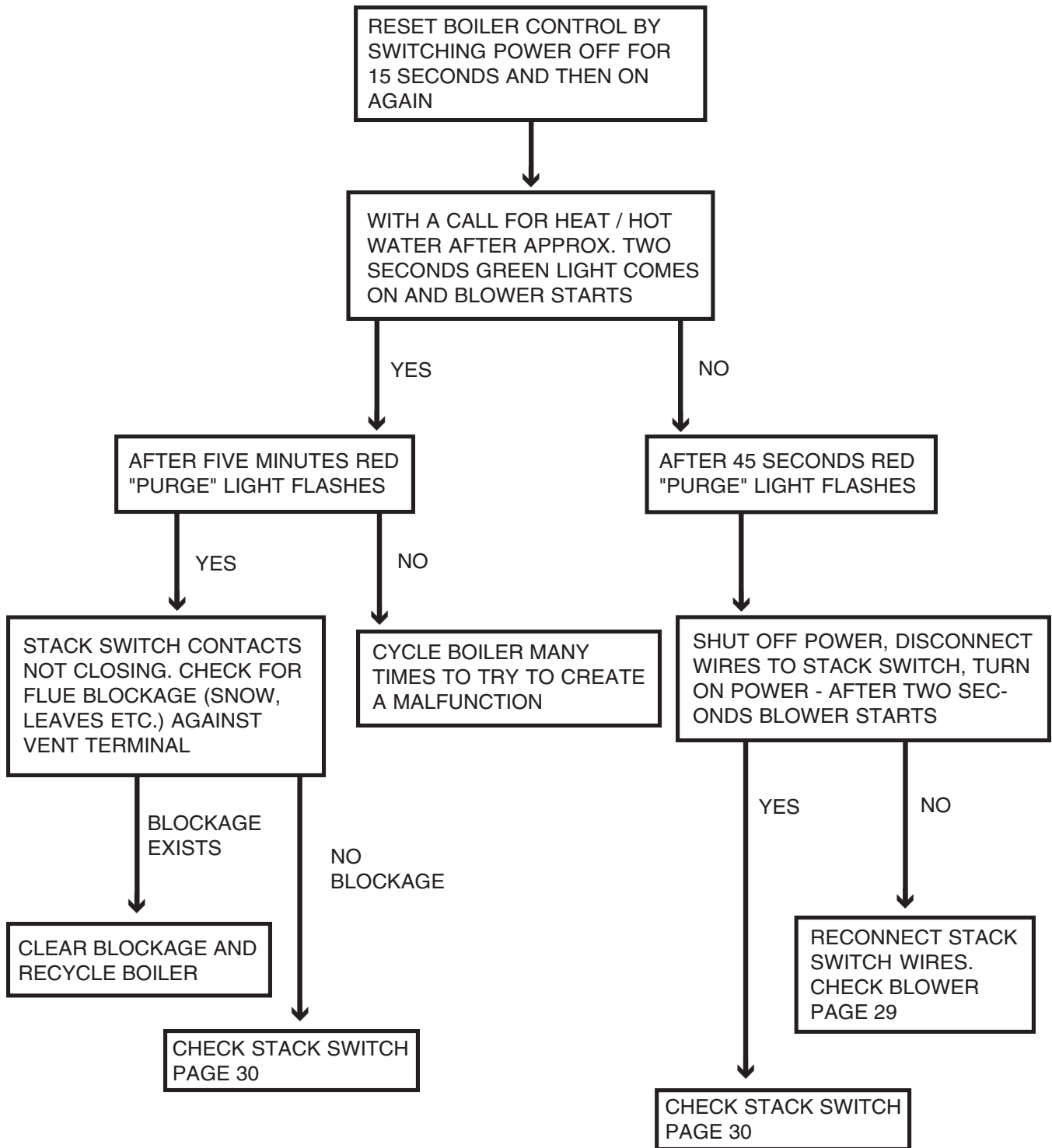

CHECKING BLOWER (YOU MUST COMPLETE PAGE 28 FIRST)

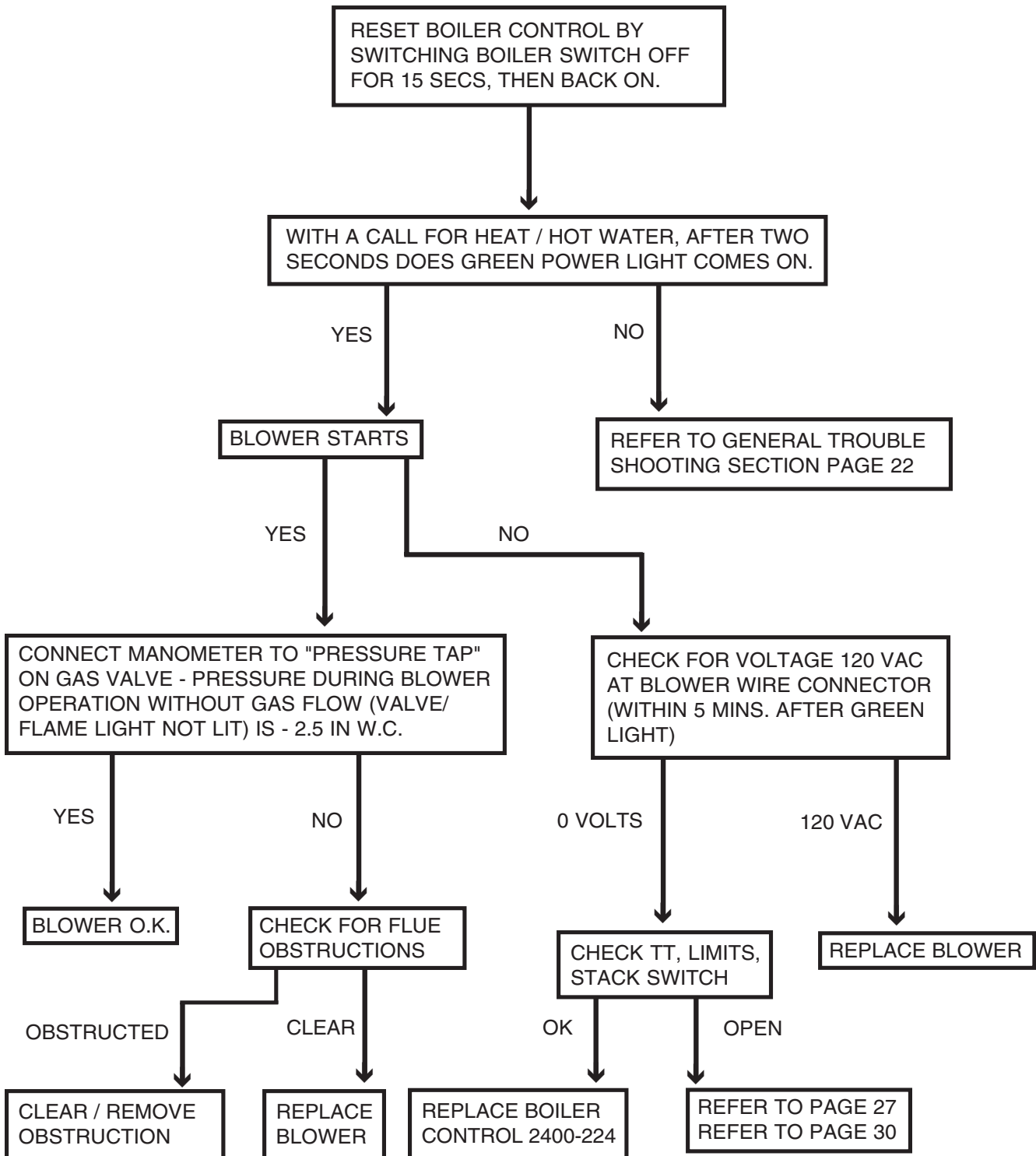

CHECKING STACK SWITCH (YOU MUST COMPLETE PAGE 29 FIRST)

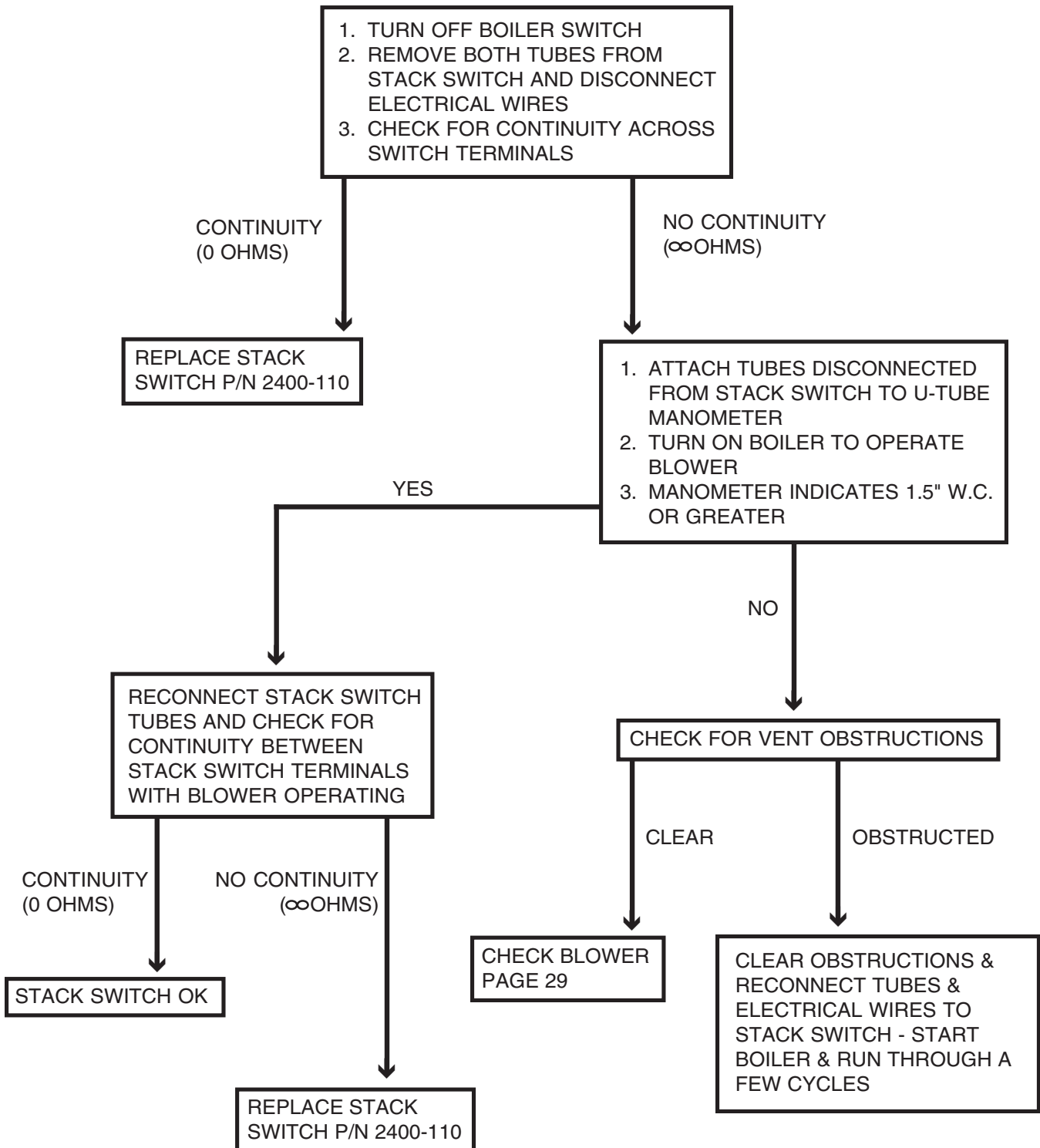

NOTE: CHECK TUBES ON STACK SWITCH FOR PROPER CONNECTIONS

RED "VALVE/FLAME" LIGHT FLASHING (YOU MUST COMPLETE PAGE 26 FIRST)

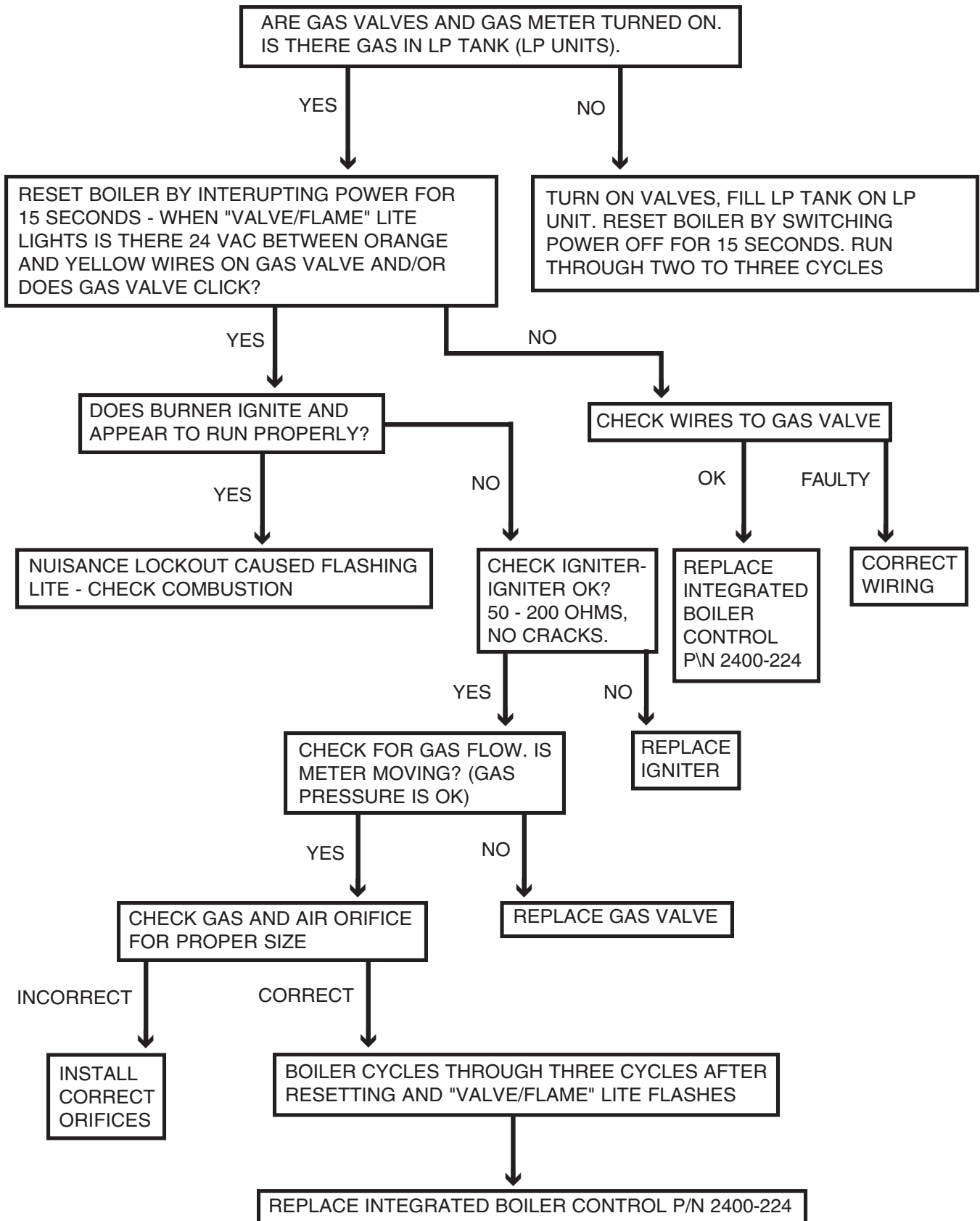

CHECKING PUMP

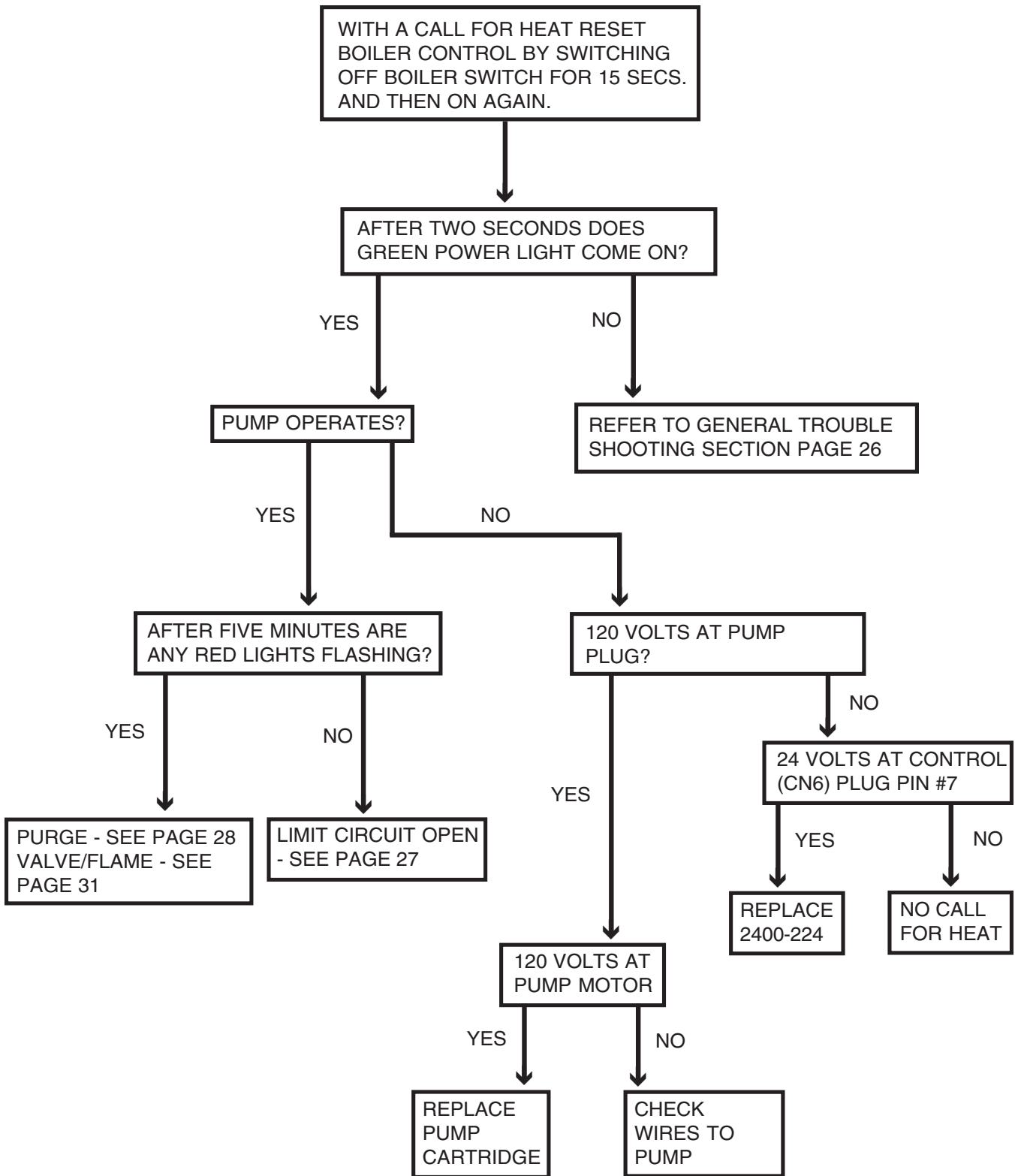

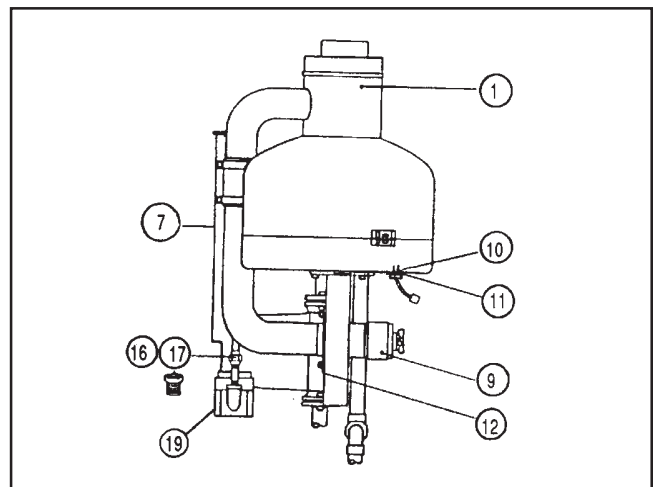
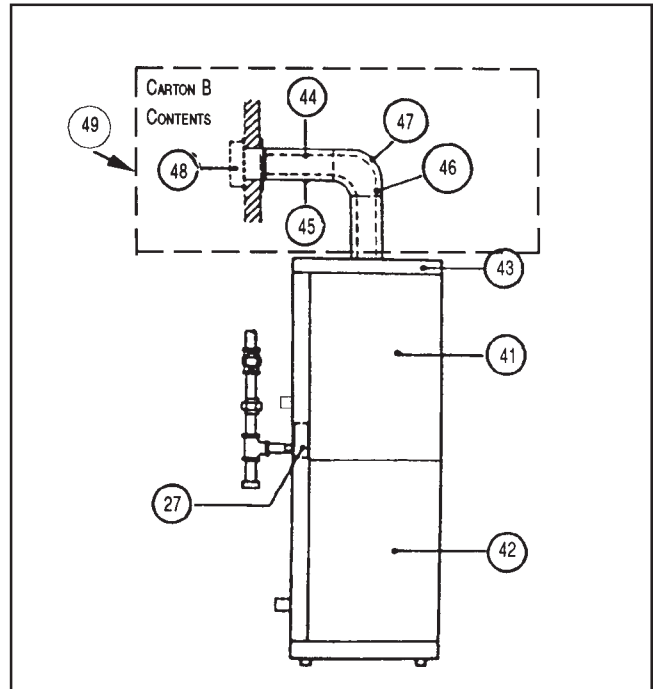
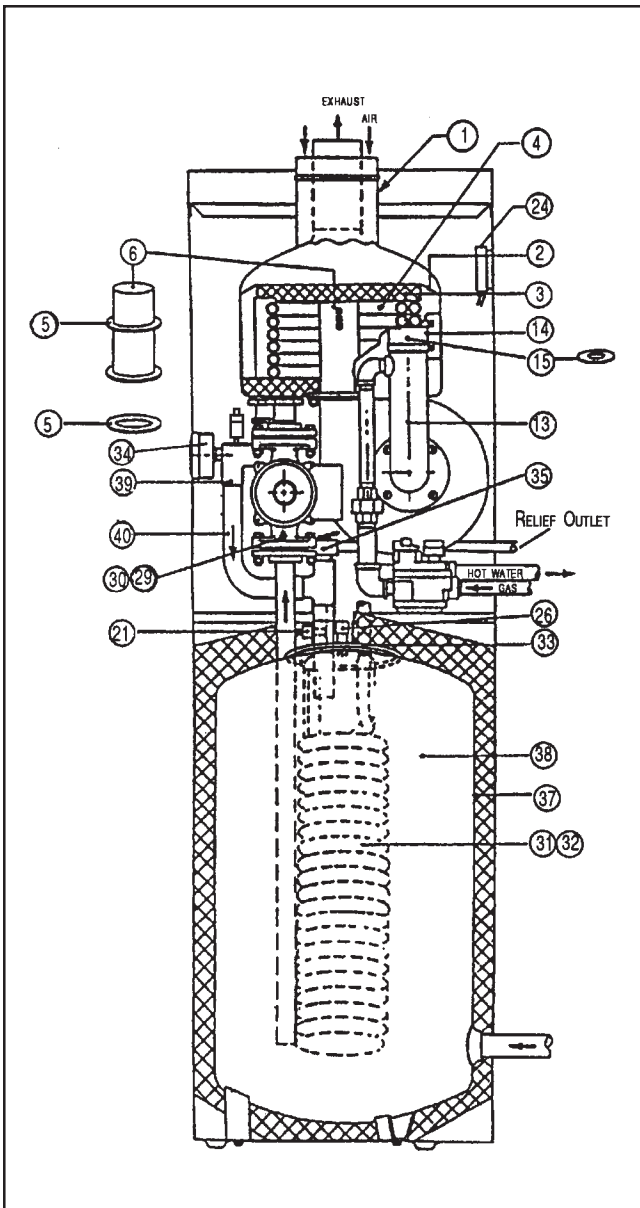
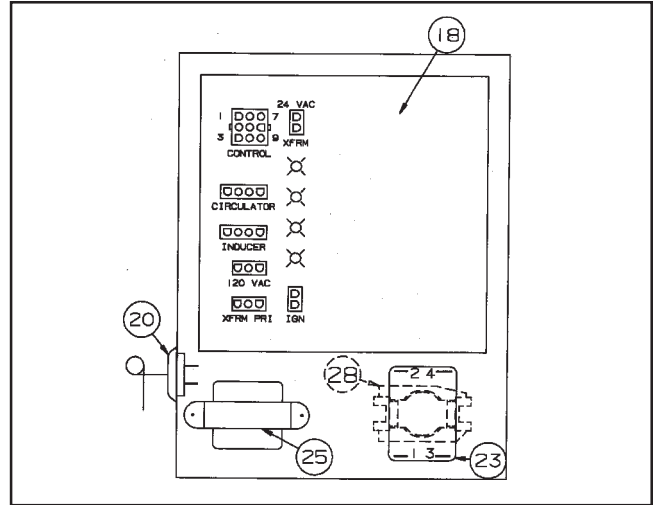
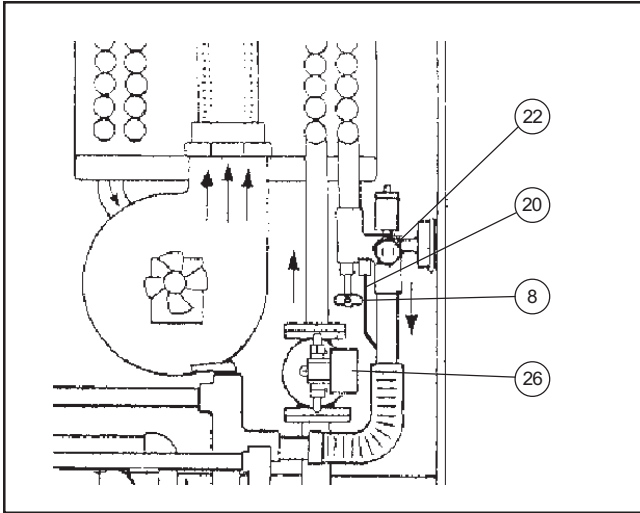

| NO. | DESCRIPTION | P / N |
|-----|---|---------------|
| 1 | Top dome for combustion chamber | 2400-038 |
| 2 | Insulation retainer | 1-428 |
| 3 | Insulation for combustion chamber coil | |
| 4 | Combustion chamber coil (H / HW / HP) | |
| 5 | Gasket, flameholder (burner / blower) | |
| 6 | Flameholder assembly, with gaskets | 2400-040 |
| 7 | Gas balance line | 2400-026 |
| 8 | Bleed line (petcock / tube assy) (H / HP) | 2400-028 |
| 9 | Blower assembly, with gaskets | 2400-002 |
| 10 | Ignitor, with gaskets | 2400-046 |
| 11 | Gasket, ignitor | gasket kit |
| 12 | Gasket, blower intake | gasket kit |
| 13 | Blower intake duct assembly | 1-236 |
| 14 | Air duct hose | 1-458 |
| 15 | Orifice, air | Specify input |
| 16 | Orifice union | 1-252 |
| 17 | Orifice, gas | Specify input |
| 18 | Boiler control | 2400-224 |
| 19 | Gas valve, neg. pressure, White Rodgers | 2400-014 |
| 20 | Safety Limit, 215° F | 2400-024 |
| 21 | Low limit Aquastat | 2400-226 |
| 22 | Operating control HW | 2400-056 |
| | Operating control H(P) | 2400-057 |
| 23 | Relay (HW-M2 series only) | 2400-010 |
| 24 | Stack Switch | 2400-110 |
| 25 | Transformer, 40VA, 120/24 VAC | 2400-006 |
| 26 | Pressure switch | 2400-106 |
| 27 | Switch, 120 volt | 1-506 |
| 28 | Time Delay Relay (H / HP) | 2400-062 |
| | Harness, wiring HW-M2 series | 1-314 |
| | Harness, wiring H-M2 series | 5-060 |
| | Gasket Kit | 2400-320 |

| NO. | DESCRIPTION | P / N |
|-----|--|----------|
| 29 | Pump, TACO 007-F4, with gaskets | 2400-004 |
| 30 | Gaskets, pump (2 each) | 1-126 |
| 31 | DHW coil (single wall), with gasket | 2400-036 |
| 32 | DHW coil (double wall), with gasket | 2400-234 |
| 33 | Gasket, DHW coil | 1-036 |
| 34 | Gauge, pressure / temperature | 2400-114 |
| 35 | Pressure relief valve (30 PSIG) | 2400-112 |
| | Thermostatic union assembly (H-M2 only) | 2400-030 |
| 37 | Transfer tank (less coil) | 2400-034 |
| | Transfer tank (less coil). Stainless Steel | 2400-238 |
| 38 | Transfer tank & coil assem. (single wall) | 2400-240 |
| | Transfer tank & coil assem. Stainless. | 2400-242 |
| 39 | Fitting, boiler discharge | 1-164 |
| 40 | Tube, boiler discharge | 1-278 |
| 41 | Jacket, front removable | 2400-256 |
| 42 | Jacket, lower front (HW-M2 only) | 2400-258 |
| 43 | Jacket, top | 2400-260 |
| 44 | Pipe, 3" flue (AL29 4C S/S) 2' - 4' | 2400-342 |
| 45 | Pipe, 5" air (Stainless Steel) 2' - 4' | 2400-336 |
| 46 | Elbow Set, 3" & 5" (AL29 4C S/S) | 2400-330 |
| 48 | Vent terminal (horizontal venting only) | 2400-276 |
| 49a | Carton B Direct Vent (Standard) | 2400-326 |
| 49b | Carton B Direct Vent (Alternate) | 2400-328 |

Installer: _____

Date of Installation: _____

Serial Number: _____

NOTES:

FOR YOUR SAFETY READ BEFORE OPERATING

WARNING: If you do not follow these instructions exactly, a fire or explosion may result causing property damage, personal injury or loss of life.

- A. This appliance does not have a pilot. It is equipped with an ignition device which automatically lights the burner. Do not try to light the burner by hand.
- B. BEFORE OPERATING smell all around the appliance area for gas. Be sure to smell next to the floor because some gas is heavier than air and will settle on the floor.
- WHAT TO DO IF YOU SMELL GAS**
- Do not try to light any appliance.
 - Do not touch any electric switch; do not use any phone in your building.
 - Immediately call your gas supplier from a neighbor's phone. Follow the gas supplier's instructions.
- If you cannot reach your gas supplier, call the fire department.
- C. Use only your hand to push in or turn the gas control knob. Never use tools. If the knob will not push in or turn by hand, don't try to repair it, call a qualified service technician. Force or attempted repair may result in a fire or explosion.
- D. Do not use this appliance if any part has been under water. Immediately call a qualified service technician to inspect the appliance and to replace any part of the control system and any gas control which has been under water.

OPERATING INSTRUCTIONS

1. STOP! Read the safety information above on this label.
2. Make sure system has been properly filled with water and thoroughly bled of air; set the thermostat to lowest setting.
3. Turn off all electric power to the appliance.
4. This appliance is equipped with an ignition device which automatically lights the burner. Do not try to light the burner by hand.

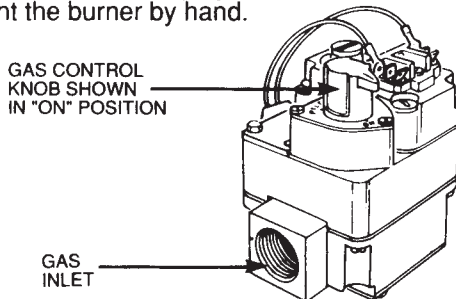

5. Remove control access panel.
 6. Push in gas control knob slightly and turn clockwise ↻ to "OFF."
- NOTE: Knob cannot be turned to "OFF" unless knob is pushed in slightly. Do not force.
7. Wait five (5) minutes to clear out any gas. Then smell for gas, including near the floor. If you smell gas, STOP! Follow "B" in the safety information above on this label. If you don't smell gas, go to the next step.
 8. Turn gas control knob counterclockwise ↻ to "ON."
 9. Replace control access panel.
 10. Turn on all electric power to the appliance.
 11. Set thermostat to desired setting.
 12. If the appliance will not operate, follow the instructions "To Turn Off Gas To Appliance" and call your service technician or gas supplier.

TO TURN OFF GAS TO APPLIANCE

1. Set the thermostat to lowest setting.
2. Turn off all electric power to the appliance if service is to be performed.
3. Remove control access panel.
4. Push in gas control knob slightly and turn clockwise ↻ to "OFF." Do not force.
5. Replace control access panel.

Figure 23. "H(P)" Wiring Diagram.

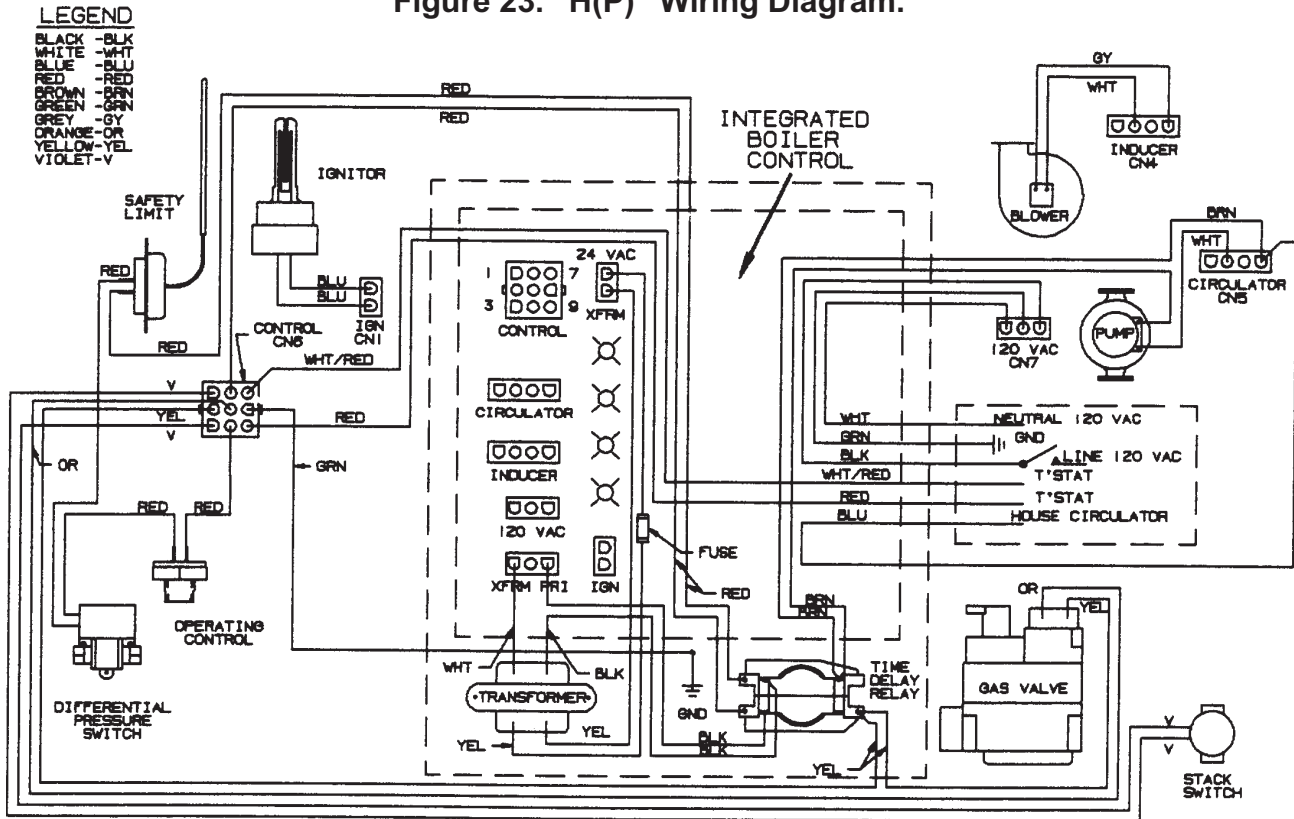

"Caution: Label all wires prior to disconnection when servicing controls. Wiring errors can cause improper and dangerous operation." Verify Proper Operation After Servicing!

Figure 24. "H(P)" Ladder Diagram.

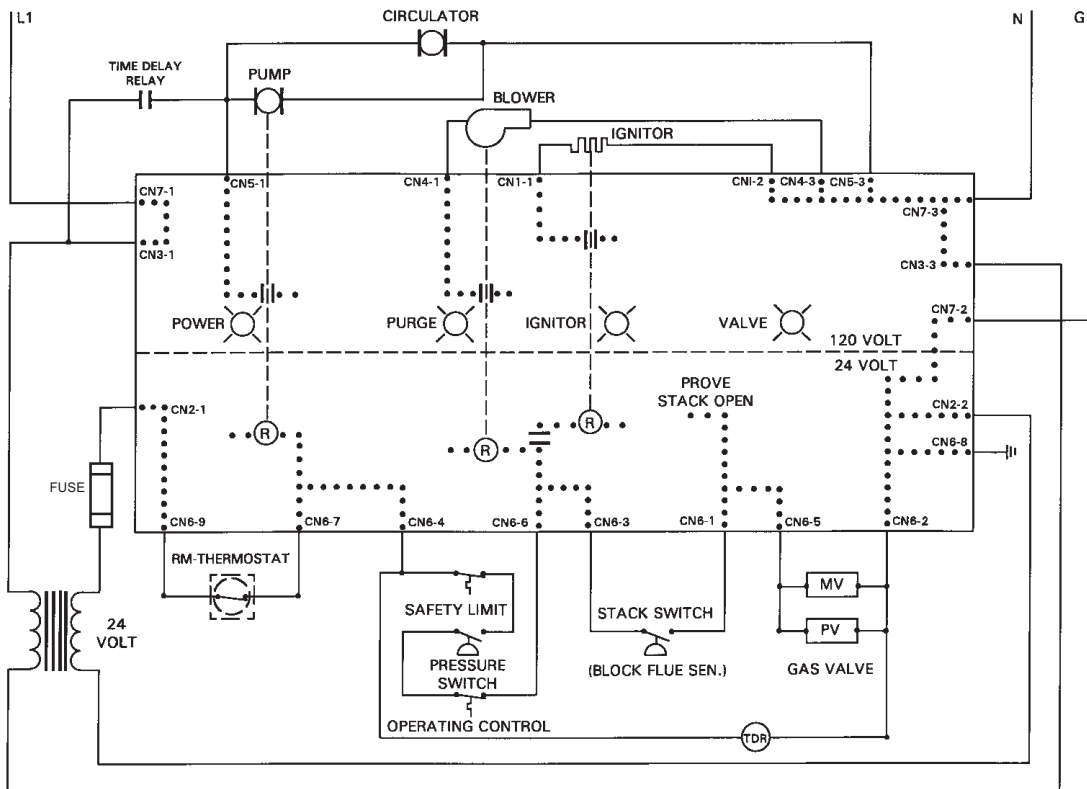
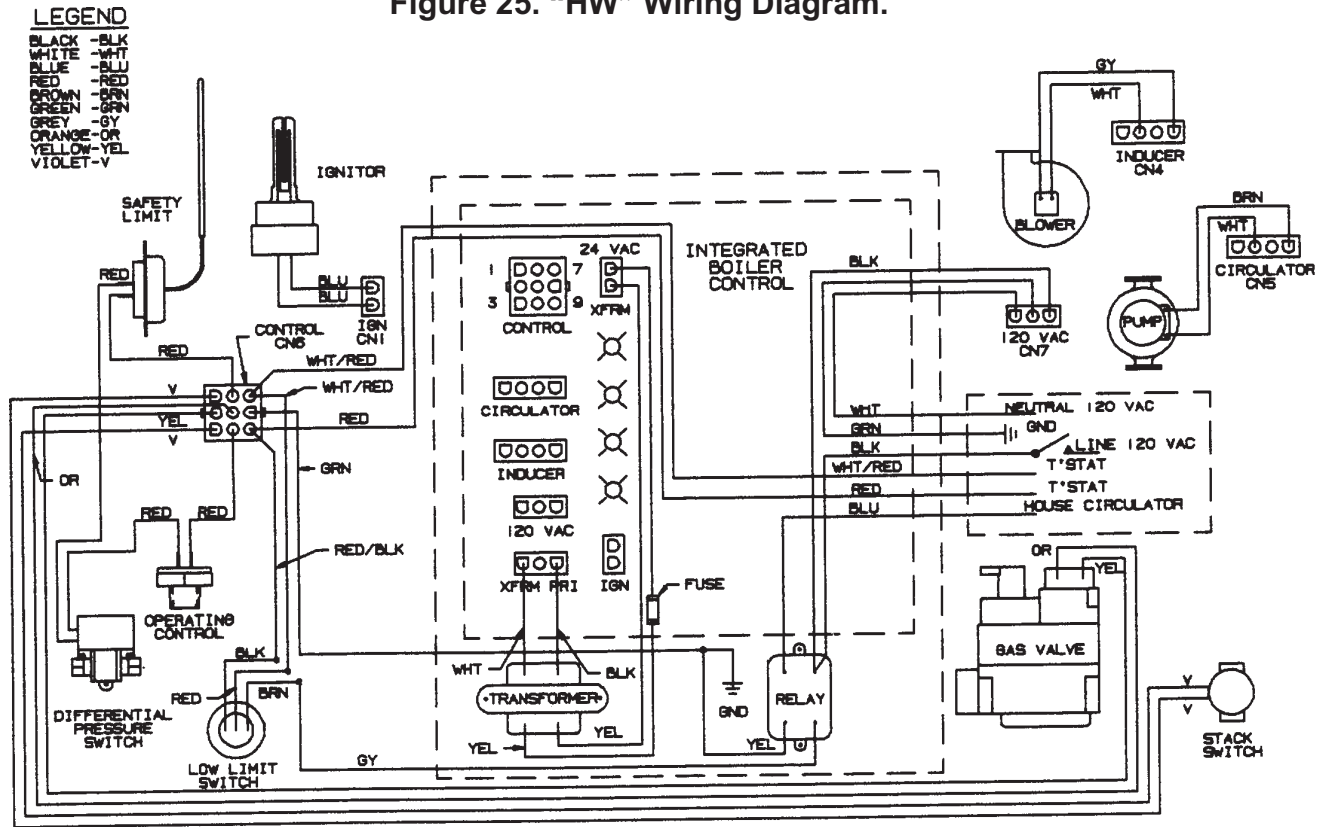
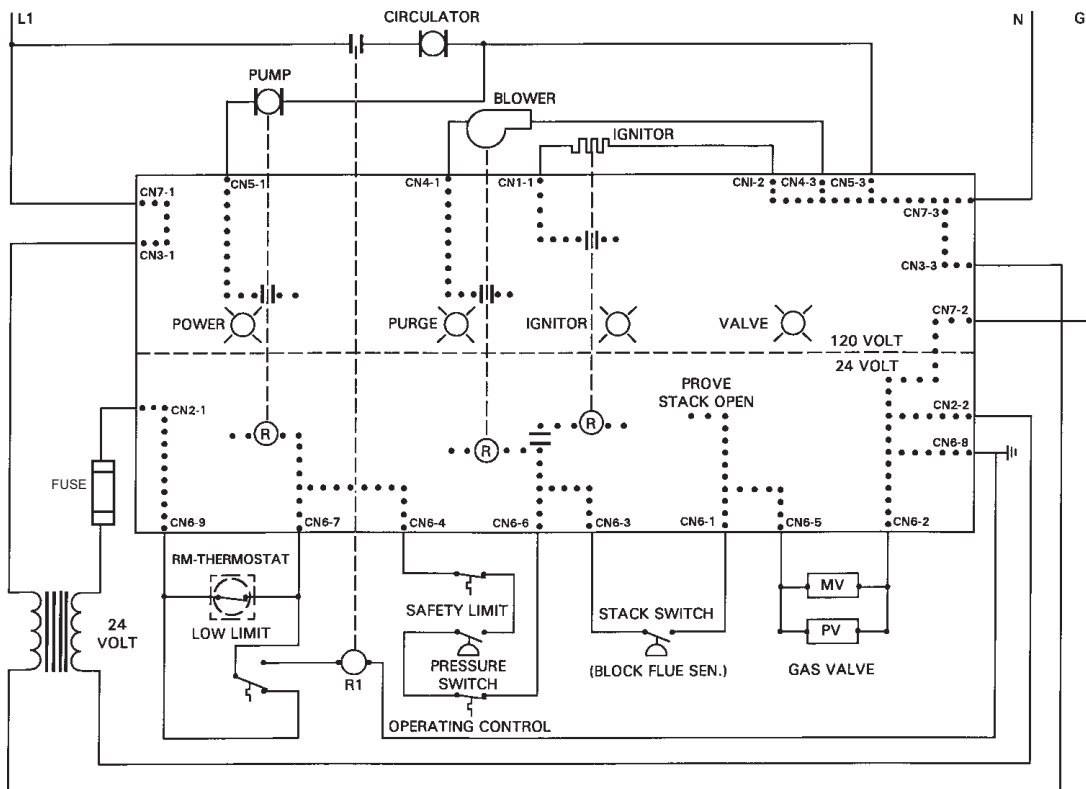

Figure 25. "HW" Wiring Diagram.



"Caution: Label all wires prior to disconnection when servicing controls. Wiring errors can cause improper and dangerous operation." Verify Proper Operation After Servicing!

Figure 26. "HW" Ladder Diagram.



Quick Reference Trouble Shooter S9301A CONTROL MODULE

NORMAL SEQUENCE

| Event | Control Function Verified | Event Confirmed |
|---|---|---|
| A. Power switch on | Integrated boiler control (S9301A) | Green "POWER" light on. Note: If internal pump is running unit may be in lockout. Reset power switch. |
| B. Prepurge (if low limit or Thermostat calling) 2 - 17) secs) | 1. Internal Pump Starts | Red "PURGE" light on. Note: If unit in purge mode without light, stack switch is not proving air flow. |
| | 2. Low limit (HW-only), operating control, safety limit, system pressure switch, stack switch | |
| | 3. Blower starts | |
| C. Igniter heats up and remains on (17 - 39 sec) | Igniter via S9301A | Red "IGNITER" light on Red "PURGE" light off Blower continues to run |
| D. Gas valve energized (37 - 43 secs) | Gas valve opens | Red "VALVE/FLAME" light on. |
| E. Ignitor off (39 sec) Gas valve energized (39 - 43+ sec) | Igniter, air & gas source | Ignitor monitors flame via flame rectification to ground |

FAILURE TO COMPLETE THIS CYCLE

| Light Event Unconfirmed | Action for Diagnosis |
|--|--|
| 1. No 120 VAC supply | 1. Read voltage between black & white wires at back of (120 VAC) plug |
| 2. Defective 24 VAC transformer | 2. Read voltage between yellow wires at back of (VAC 24XFMR) plug |
| 3. Defective S9301A module | 3. Replace S9301A part #2400-224 |
| 1. Internal pump defective or air bound | 1. Check for 120 VAC at module pins marked circulator (opposite brown and white) |
| 2. Defective low limit, operating control, safety limit or differential pressure switch | 2. Jump control wires, one control at a time to identify open circuit control, no continuity. |
| 3. Defective inducer blower | 3. Check for 120 VAC at module pins marked inducer (opposite gray and white wires) |
| Igniter does not heat up - look for heat up at ignitor base | Check for 120 VAC at pins marked IGNR (blue wires) during ignitor light "on" |
| 1. Stack switch does not confirm air flow. 2. Gas valve has short. | Check for 24 VAC between orange and yellow wires on gas valve when red "VALVE / FLAME" light is on |
| Unit transfer to purge 12-15 secs after "valve / flame" light is on and repeats sequence | See trouble shooting section under "cross contamination" & "short cycling" in service manual |

QUICK REFERENCE TROUBLE SHOOTER

FOR MORE INFORMATION SEE INDEX

A. SHORT CYCLING: Unit shuts down before reaching limit. Restarts within one minute without resetting.

1. Cross contamination in air source: remove air elbow from top of air orifice hose coupling and utilize air from space. (Do not vent both 3" and 5" pipe to chimney)
2. Wrong air or gas orifice combination for size or fuel source. (Refer to Heatmaker gas orifice chart only).
3. Limits operating intermittently or calibration out of specification.

B. HEATMAKER OVERHEATS QUICKLY: boiling noise in combustion chamber.

1. Air in combustion coil or in pump: purge system.
2. Pump failure or control failure.

C. DELAYED IGNITION: Unit starts or stops with a "pop".

1. Wrong gas orifice for fuel or air orifice size.
2. LP-Gas regulator lock up 3" or greater above run pressure: correct regulator and check gas pipe sizing against piping chart in installation manual. Set regulator for maximum run pressure of 9" W.C.
3. Remove blower and inspect flame holder (burner) for hole.
4. Check that blower flanges and gas piping are sealed.

D. OCCASIONAL LOCK OUTS: Requires interruption of power to restart.

1. Air in system causes safety limit to open. Vent air from system and determine source of air.
2. Cross contamination in direct vent piping: measure CO² in air supply above air orifice. (1% or greater will cause lock out and unit damage.)
3. Condensing of moisture in combustion chamber:
 - a. H-M2 units: No thermostatic union in system supply piping, or thermostat does not close below 160 °F.
 - b. HW-M2 units: System circulating pumps not wired to Heatmaker "blue" wire. See field wiring prints in installation manual.
 - c. Improper pitch of vent pipe allowing moisture to return to combustion chamber or vent cap installation problem.
4. Occasional failure of blower: red "PURGE" light will be flashing. May also be caused by defective contact on strap on operating control.
5. Zone control short cycling or voltage problem: Operate thermostats in various sequences to create suspect problem. Note: TACO zone valves must have isolating relay between end switch and Heatmaker.

Installer's "Leave It Right" Check List

| | | |
|-------------------|--|----------------------|
| VENTING | | √ |
| 1. | DIRECT - Horizontal, pitched down away. Vertical, units fired at 130,000 BTU only. | Pg. 9 Fig. 12 |
| 2. | CHIMNEY - Vent to lined chimney only or use 'B' Vent. See table 11-3 & 11-2. | Pg. 4, 5 |
| PIPING | | √ |
| 1. | GAS - Must be trapped, pipe down from above the unit only. | Pg. 9 Fig. 12 |
| 2. | DOMESTIC WATER - Tempering valve installed & trapped. | Pg. 9 |
| 3. | DOMESTIC WATER - Appropriate GPM flow restrictor installed. | Pg. 9 |
| 4. | HYDRONIC HEAT - Properly sized expansion tank (HW must have #30) in supply piping. | Pg. 10 |
| 5. | HYDRONIC HEAT - Auto air eliminator, system pump and flow check installed in supply. | Pg. 10 |
| 6. | HYDRONIC HEAT - Thermostatic union installed in supply on H & HP units. | Pg. 12 Fig. 16 |
| ELECTRICAL | | √ |
| 1. | BLUE WIRE (field wiring box) - Wired to power system circulator(s). | Pg. 13 Fig. 18-21 |
| 2. | THREE WIRE ZONE VALVES - (i.e. Taco, Watts, Sparco) wired with isolation relay. | Pg. 13 Fig. 20 |
| 3. | SET THERMOSTAT ANTICIPATOR - .9 amp for single loop systems or Taco Zone Valves. | Pg. 13 Fig. 18 |
| IMPORTANT | | √ |
| 1. | SHIPPING BOLTS - Removed from tank base on HW units, (see below). * | Pg. 3 |
| 2. | WARRANTY CARD - Completed and returned to T.H.I. Leave Service Manual with unit. | |



TRIANCO-HEATMAKER, Inc.
 111 York Avenue
 Randolph, Massachusetts 02368
 Telephone (781) 986-9100
 Fax (781) 986-9907

Part No. 1 - 510
 2 M - 11/19/97