



**INSTRUCTION MANUAL
MANUAL DE INSTRUCCIONES**

Model Numbers: 18DYW/271YW/441YW
No. de Modelo: 18DYW/271YW/441YW

REFRIGERATOR
(REFRIGERADOR)

CAUTION:
BEFORE USE, PLEASE READ AND FOLLOW ALL SAFETY RULES AND OPERATING
INSTRUCTIONS.

Avanti Products, A Division of The Mackle Co., Inc.
P.O. Box 520604 - Miami, Florida 33152
www.avantiproductions.com

Avanti has a policy of continuous improvement on its products and reserves the right to change material and specifications without notice.

Warranty Information

Thank you for purchasing this fine Avanti product. Please fill out this card and return it within 100 days of purchase and receive these important benefits:

➤ **Confirm your warranty:**

Your prompt product registration confirms your right to the protection available under the terms and conditions of your Avanti warranty.

➤ **Protect your product:**

We will keep the model number and date of purchase of your new Avanti product on file to help you refer to this information in the event of an insurance claim such as fire or theft.

➤ **Promote better products:**

We value your input. Your responses will help us develop products designed to best meet your future needs.

------(detach here)-----

Avanti Registration Card

Name	Model#	Serial#
Address	Date Purchased	Store/Dealer Name
City	State	Zip
Area Code	Occupation	
As Your Primary Residence, Do You:		
<input type="checkbox"/> Own <input type="checkbox"/> Rent		

Did You Purchase An Additional Warranty:

Extended Food Loss None

Reason For Choosing This Avanti Product:

Please indicate the most important factors that influenced your decision to purchase this product.

Price

Product Features

Avanti Reputation

Product Quality

Salesperson Recommendation

Friend/Relative Recommendation

Warranty

Other _____

Your Age:

under 18 18-25 26-30

31-35 36-50 over 50

Marital Status:

Married Single

Is This Product Used In The:

Home Business

How Did You Learn About This Product:

Advertising Product Features

In Store Demo Personal Demo

Other _____

Comments _____

HELP US HELP YOU...

Read this guide carefully.

It is intended to help you operate and maintain your new refrigerator properly.

Keep it handy to answer your questions. If you don't understand something or you need more help, please call:

Avanti Customer Service
800-220-5570

Keep proof of original purchase date (such as your sales slip) with this guide to establish the warranty period.

CAUTION:

**THIS REFRIGERATOR IS NOT
DESIGNED FOR THE STORAGE OF
MEDICINE OR OTHER MEDICAL
PRODUCTS.**

Write down the model and serial numbers.

You'll find them on a plate located on the bottom outside wall of the refrigerator.

Please write these numbers here:

Date of Purchase

Model Number

Serial Number

Use these numbers in any correspondence or service calls concerning your refrigerator.

If you received a damaged refrigerator, immediately contact the dealer (or builder) that sold you the refrigerator.

Save time and money. Before you call for service, check the Troubleshooting Guide. It lists causes of minor operating problems that you can correct yourself.

IF YOU NEED SERVICE

We're proud of our service and want you to be pleased. If for some reason you are not happy with the service you receive, here are some steps to follow for further help.

FIRST, contact the people who serviced your refrigerator. Explain why you are not pleased. In most cases, this will solve the problem.

NEXT, if you are still not pleased, write all the details, including your telephone number, and send to:

Customer Service
Avanti Products
10880 NW 30 Street
Miami, FL 33172

Table of Contents

Warranty Information and Registration Card	2
Help Us Help You	3
Parts and Features	5
Important Safety Instructions	6
Installation Instructions	6
Before Using Your Refrigerator	6
Installation of Your Refrigerator	6
Electrical Connection	7
Operating Your Refrigerator	8
Temperature Control	8
Using Your Ice Cube Trays	8
Care and Maintenance	8
Defrosting Your Refrigerator	8
Changing the Reversible Door	9, 10
Cleaning Your Refrigerator	11
Maintenance of Your Refrigerator	11
Vacation Time	11
Moving Your Refrigerator	11
Energy Saving Tips	11
Troubleshooting Guide	12
Service For Your Refrigerator	13
Your Avanti Products Warranty	14
18DYW/271YW/441YW Parts Breakdown	15, 16, 17
18DYW/271YW/441YW Parts List	18, 19, 20
18DYW/271YW/441YW Wiring Diagram	21
SPANISH VERSION	22, 23, 24, 25

**PARTS AND FEATURES
NOMBRES DE LAS PIEZAS**

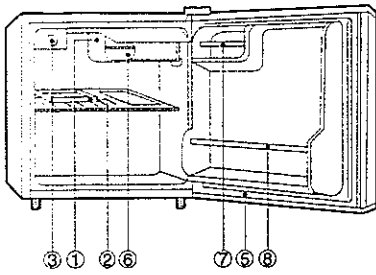

18DYW

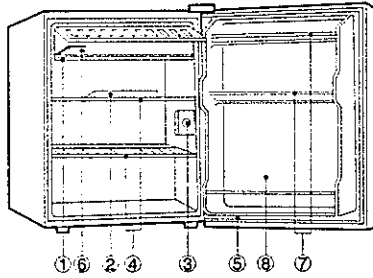

271YW

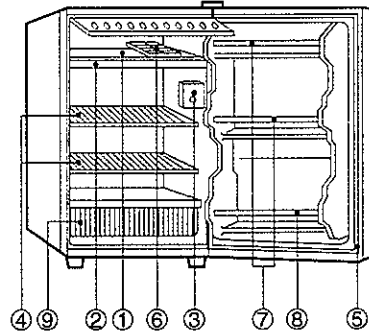

441YW

- ① Freezer/Congelador
- ② Drain Pan/ Recipiente De Deshielo (Use of Defrost Only)
- ③ Control Box/Control De Temperatura
- ④ Plastic Coated Shelf/Perillas De Plástico
- ⑤ Magnetic Door Seal/Sello Magnético De Puerta
- ⑥ Ice Cube Tray/Recipiente Para Hielos
- ⑦ Rack/Compartimiento De Multi-Usos
- ⑧ Bottle Rack/Compartimiento Para Botellas
- ⑨ Crisper/Gaveta

Important Safety Instructions

 WARNING ⚡	To reduce the risk of fire, electrical shock, or injury when using your refrigerator, follow these basic precautions:
<ul style="list-style-type: none">• Read all instructions before using the refrigerator.• DANGER or WARNING: Risk of child entrapment.• Child entrapment and suffocation are not problems of the past. Junked or abandoned appliances are still dangerous... even if they will "just sit in the garage a few days."• Before you throw away your old refrigerator or freezer : Take off the doors. Leave the shelves in place so that children may not easily climb inside.• Never allow children to operate, play with, or crawl inside the refrigerator.• Never clean refrigerator parts with flammable fluids. The fumes can create a fire hazard or explosion.• Do not store or use gasoline or any other flammable vapors and liquids in the vicinity of this or any other refrigerator. The fumes can create a fire hazard or explosion. <p style="text-align: center;">- Save these instructions -</p>	

INSTALLATION INSTRUCTIONS

➤ Before Using Your Refrigerator

- Remove the exterior and interior packing.
- Check to be sure you have all of the following parts:
 - 1 Ice cube tray.
 - 1 Drip tray.
 - Instruction manual.
- Before connecting the refrigerator to the power source, let it stand upright for approximately 2 hours. This will reduce the possibility of a malfunction in the cooling system from handling during transportation.
- Clean the interior surface with lukewarm water using a soft cloth.

➤ Installation of Your Refrigerator

- This appliance is designed to be free standing only, and should not be recessed or built-in.
- Place your refrigerator on a floor that is strong enough to support the refrigerator when it is fully loaded. To level your refrigerator, adjust the legs at the front of the refrigerator.
- Allow 5 inches of space between the back and sides of the refrigerator, which allows the proper air circulation to cool the compressor.
- Locate the refrigerator away from direct sunlight and sources of heat (stove, heater, radiator, etc.). Direct sunlight may affect the acrylic coating and heat sources may increase electrical consumption. Extreme cold ambient temperatures may also cause the refrigerator not to perform properly.
- Avoid locating the refrigerator in moist areas.
- Plug the refrigerator into an exclusive, properly installed-grounded wall outlet. Do not under any circumstances cut or remove the third (ground) prong from the power cord. Any questions concerning power and or grounding should be directed toward a certified electrician or an authorized Avanti Products service center.
- After plugging the appliance into a wall outlet, allow the unit to cool down for 2-3 hours before placing food in the refrigerator compartment.

➤ **Electrical Connection**

⚡ Warning ⚡

Improper use of the grounded plug can result in the risk of electrical shock. If the power cord is damaged, have it replaced by an authorized Avanti Products service center.

This refrigerator should be properly grounded for your safety. The power cord of this refrigerator is equipped with a three-prong plug which mates with standard three prong wall outlets to minimize the possibility of electrical shock.

Do not under any circumstances cut or remove the third ground prong from the power cord supplied.

Use of extension cords is not recommended.

This refrigerator requires a standard 115/120-volt, 60Hz electrical outlet with three-prong ground. The cord should be secured behind the refrigerator and not left exposed or dangling to prevent accidental injury.

Never unplug the refrigerator by pulling the power cord. Always grip the plug firmly and pull straight out from the receptacle.

OPERATING YOUR REFRIGERATOR

➤ Setting the Temperature Control

- To control the internal temperature, adjust the control dial according to the ambient temperature or purpose of use.
- The first time you turn the unit on, set the temperature control to "7".
- The range of the temperature control is from position "1" the warmest to "7" the coldest. After 24 to 48 hours, adjust the temperature control to the setting that best suits your needs. The setting of "4" should be correct for home or office refrigerator use.

NOTE:

- If the unit is unplugged, power lost, or turned off; you must wait 3 to 5 minutes before restarting the unit. If you attempt to restart before this time delay, the refrigerator will not start.

➤ Use of the Ice Cube Trays

- For your ice requirements, fill approximately $\frac{3}{4}$ of the tray after washing it.
- To release the ice cubes, hold the tray upside down and twist slightly at both ends until the pieces of ice fall.

CARE AND MAINTENANCE

➤ Defrosting Your Refrigerator

Defrost the refrigerator when the frost accumulated on the evaporator is about 5mm (1/5 inch) thick. Set the thermostat dial to "OFF". Remove frozen or perishable foods. Insert drip tray below the freezer compartment only for defrosting (as shown below). Defrosting usually takes a few hours. After defrosting, empty water from drip tray and return the thermostat dial to the desired position. To defrost quickly remove all foods from the refrigerator and leave the door open. Never use a knife or other metal instrument to scrape ice/frost from the evaporator.

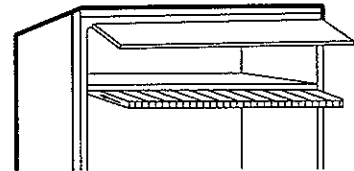

(Model 441YW only)

➤ Changing the Reversible Door

This refrigerator has been built with the door hinges on the right.
If you wish to change the opening direction, follow the instruction below:

- Unplug the refrigerator from its electrical outlet.
- Empty everything in the refrigerator, including shelves, food, etc.

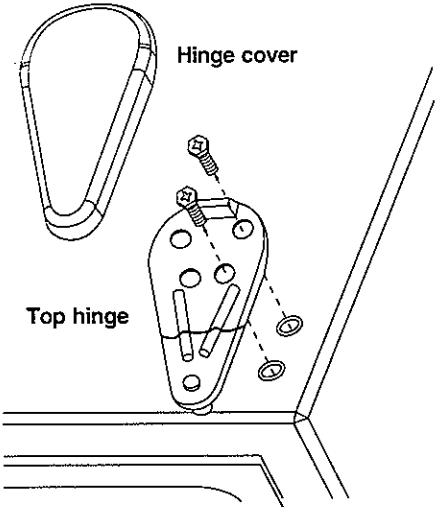
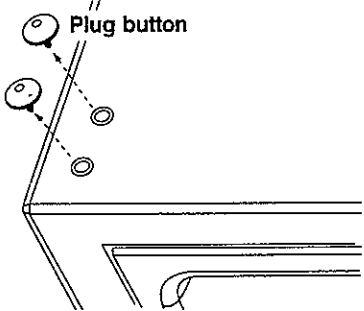
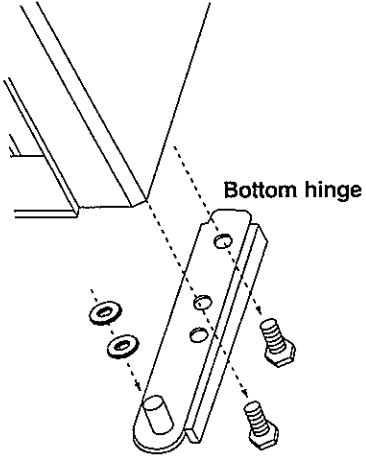
<ol style="list-style-type: none">1. Remove the hinge cover on the right top of the cabinet.2. Remove the two screws (using a ratchet tool with a 8MM socket) that hold the top hinge to the cabinet. Keep these screws for later use.3. Lift the top hinge straight up to free the pin from the socket on the top of the door.4. Lift the door and place it on a padded surface to prevent scratching it.	 <p>The diagram illustrates the first four steps of the process. On the left, a separate 'Hinge cover' is shown. On the right, a 'Top hinge' is being removed from the cabinet. Two screws are shown being unscrewed from the hinge. The hinge is then shown being lifted away from the cabinet, with a pin being freed from its socket on the top of the door.</p>
<ol style="list-style-type: none">5. Remove the plug buttons from the upper left holes as illustrated and transfer them to the uncovered holes at the right side. Be sure to press the plug buttons firmly into the holes.	 <p>The diagram shows the upper left corner of the cabinet. Three circular 'Plug buttons' are shown being moved from their original positions on the left to new positions on the right side of the cabinet. The buttons are shown being pressed into the holes.</p>
<ol style="list-style-type: none">6. Lay the cabinet on its side down on the floor. Remove the two screws that hold the bottom hinge to the cabinet using a 10MM socket. Keep these screws and washers for later use.	 <p>The diagram shows the cabinet lying on its side. A 'Bottom hinge' is being removed from the cabinet. Two screws are shown being unscrewed from the hinge. The hinge is then shown being lifted away from the cabinet.</p>

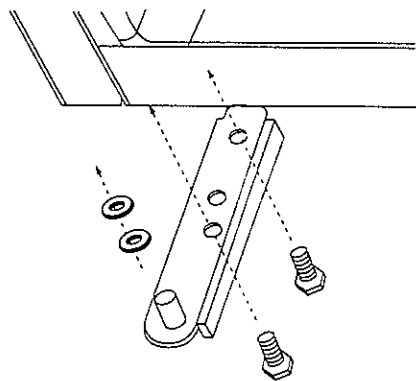
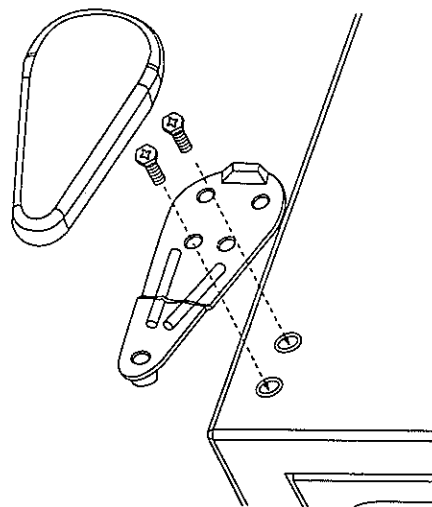
<p>7. Insert the bottom hinge at the left side using the two screws previously removed in step 6. NOTE: Do not tighten screws.</p> <p>8. Stand the cabinet.</p> <p>9. Replace the door making sure the bottom socket enters the bottom hinge pin. Be sure washers are in place.</p>	
<p>10. While holding the door in the closed position, secure the top hinge at the left side using the two screws previously removed at the beginning in step 2. Do not tighten the screws until the top of the door is leveled with the top cabinet.</p> <p>11. Replace the hinge cover.</p>	
<p>12. Tools required: -8MM & 10MM socket-ratchet -Putty knife or thin-blade screwdriver</p>	

➤ Cleaning Your Refrigerator

- Turn the temperature control to "OFF", unplug the refrigerator, and remove the food, shelves, and trays.
- Wash the inside surfaces with a warm water and baking soda solution. The solution should be about 2 tablespoons of baking soda to a quart of water.
- Wash the shelves and trays with a mild detergent solution.
- The outside of the refrigerator should be cleaned with mild detergent and warm water.
- Wring excess water out of the sponge or cloth when cleaning area of the controls, or any electrical parts.
- Wash the outside cabinet with warm water and mild liquid detergent. Rinse well and wipe dry with a clean soft cloth.

➤ Vacation Time

- **Short vacations:** Leave the refrigerator operating during vacations of less than three weeks.
- **Long vacations:** If the appliance will not be used for several months, remove all food and unplug the power cord. Clean and dry the interior thoroughly. To prevent odor and mold growth, leave the door open slightly; blocking it open if necessary.

➤ Moving Your Refrigerator

- Remove all the food.
- Securely tape down all loose items inside your refrigerator.
- Turn the leveling screws up to the base to avoid damage.
- Tape the door shut.
- Be sure the refrigerator stays secure in the upright position during transportation. Also protect outside of refrigerator with a blanket, or similar item.

➤ Energy Saving Tips

- The refrigerator should be located in the coolest area of the room, away from heat producing refrigerator or heating ducts, and out of the direct sunlight.
- Let hot foods cool to room temperature before placing in the refrigerator. Overloading the refrigerator forces the compressor to run longer.
- Be sure to wrap foods properly, and wipe containers dry before placing them in the refrigerator. This cuts down on frost build-up inside the refrigerator.
- Refrigerator storage bin should not be lined with aluminum foil, wax paper, or paper toweling. Liners interfere with cold air circulation, making the refrigerator less efficient.
- Organize and label food to reduce door openings and extended searches. Remove as many items as needed at one time, and close the door as soon as possible.

PROBLEMS WITH YOUR REFRIGERATOR?

You can solve many common refrigerator problems easily, saving you the cost of a possible service call. Try the suggestions below to see if you can solve the problem before calling the servicer.

TROUBLESHOOTING GUIDE

PROBLEM	POSSIBLE CAUSE
Refrigerator does not operate.	Not plugged in. The circuit breaker tripped or blown fuse.
Compressor turns on and off frequently.	The room temperature is hotter than normal. A large amount of food has been added to the refrigerator. The door is open too often. The door is not closed completely. The temperature control is not set correctly. The door gasket does not seal properly. The refrigerator does not have the correct clearances.
	Check to assure that the refrigerator is level.
Vibrations. The refrigerator seems to make too much noise.	The rattling noise may come from the flow of the refrigerant, which is normal. As each cycle ends, you may hear gurgling sounds caused by the flow of refrigerant in your refrigerator. Contraction and expansion of the inside walls may cause popping and crackling noises. The refrigerator is not level.
The door will not close properly.	The refrigerator is not level. The door was reversed and not properly installed. The gasket is dirty. The shelves, bins, or baskets are out of position.

SERVICE FOR YOUR REFRIGERATOR

We are proud of our customer service organization and the network of professional service technicians that provide service on your Avanti refrigerators. With the purchase of your Avanti refrigerator, you can have the confidence that if you ever need additional information or assistance, the Avanti Products Customer Service team will be here for you. Just call us toll-free.

AVANTI PRODUCTS CUSTOMER SERVICES

Product Information 800-323-5029	Whatever your questions are about our products, help is available.
Part Orders 800-220-5570	You may order parts and accessories that will be delivered directly to your home. You may order these items by personal check, money order, Master Card, or Visa.
In-Home Repair Service 800-220-5570	An Avanti Products authorized service center will provide expert repair service, scheduled at a time that is convenient for you. Our trained servicers know your refrigerator inside and out.

YOUR Avanti Products WARRANTY

Staple your sales receipt here. Proof of original purchase date is needed to obtain service under warranty.

WHAT IS COVERED
LIMITED ONE-YEAR WARRANTY

For one year from the date of purchase by the original owner, Avanti Products will, at its option, repair or replace any part of the refrigerator which proves to be defective in material or workmanship under normal use. During this period Avanti Products will provide all parts and labor necessary to correct such defects free of charge, so long as the refrigerator has been installed and operated in accordance with the written instructions in this manual. In rental or commercial use, the warranty period is 90 days. All Avanti Appliances of 3.5 cubic foot capacity or less must be brought/sent to the appliance service shop for repair.

LIMITED SECOND THROUGH FIFTH YEAR WARRANTY

For the second through the fifth year from date of original purchase, Avanti Products will provide a replacement compressor free of charge due to a failure. You are responsible for the service labor and freight charges. In rental or commercial use, the limited compressor warranty is one year and nine months. Cost to move the refrigerator to the servicers' shop and back to the user's home, as may be required, are the user's responsibility.

WHAT IS NOT COVERED

- Content losses of food due to spoilage.
- Incidental or consequential damages.
- Parts and labor costs for the following will not be considered as warranty:
 - Evaporator doors, door springs, and/or frames.
 - Inner door panels, door shelves, door rails, and/or door supports.
 - Chest refrigerator lid liners.
 - Vegetable crispers.
 - Light bulbs and/or plastic housing.
 - Plastic cabinet liners.
- Punctured evaporator that voids the warranty on the complete sealed system.
- Repairs performed by unauthorized servicers.
- Service calls that do not involve defects in material or workmanship such as customer education, door reversal, or proper installation.
- Service calls that are related to external problems, such as abuse, misuse, inadequate electrical power, accidents, fire, floods, or acts of God.
- Replacement of house fuses or resetting circuit breakers.
- Failure of the product if it is used for other than its intended purpose.
- This warranty does not apply outside the Continental U.S.A.

PARTS BREAKDOWN(18DYW)

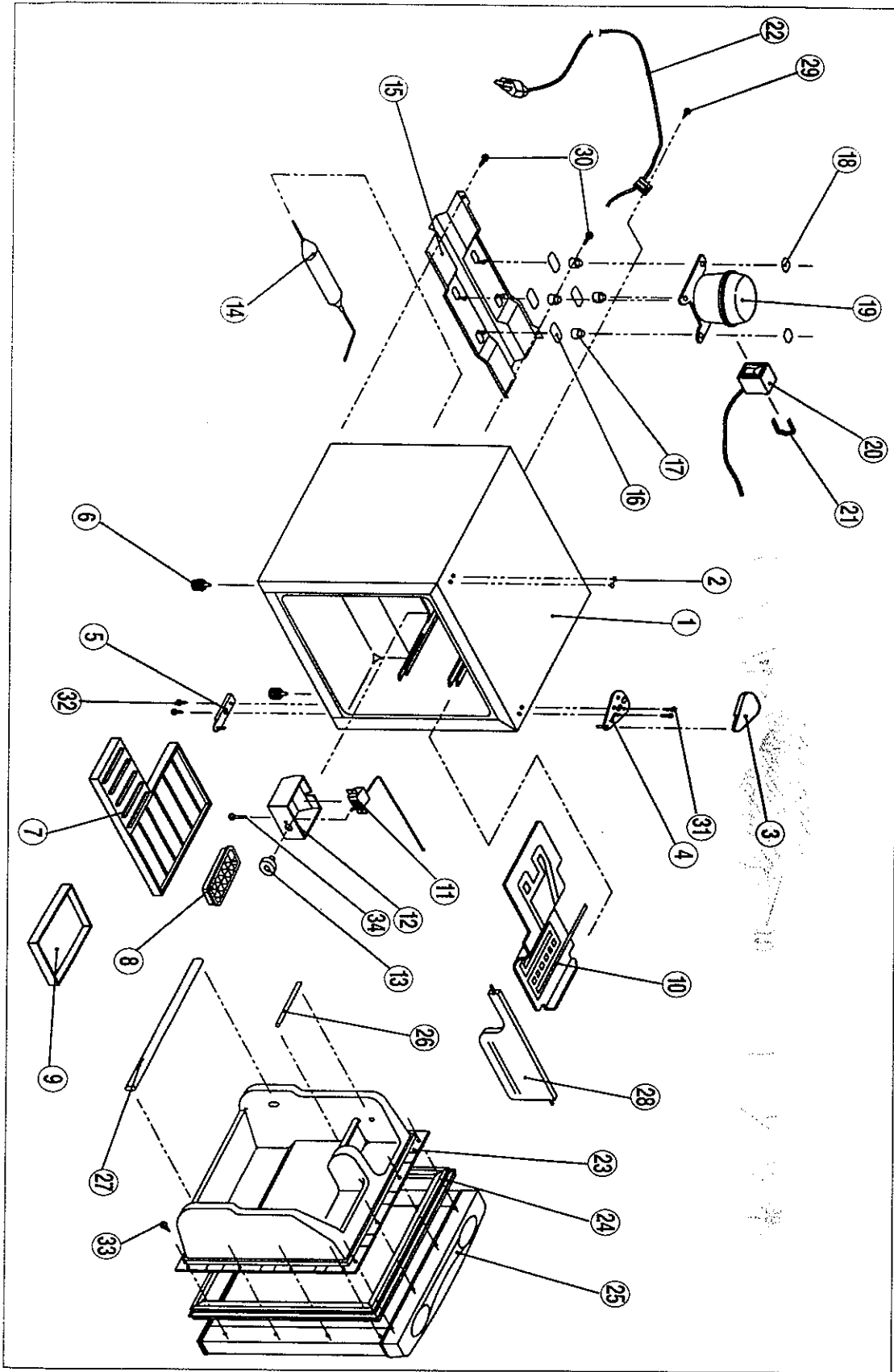

PARTS BREAKDOWN(271YW)

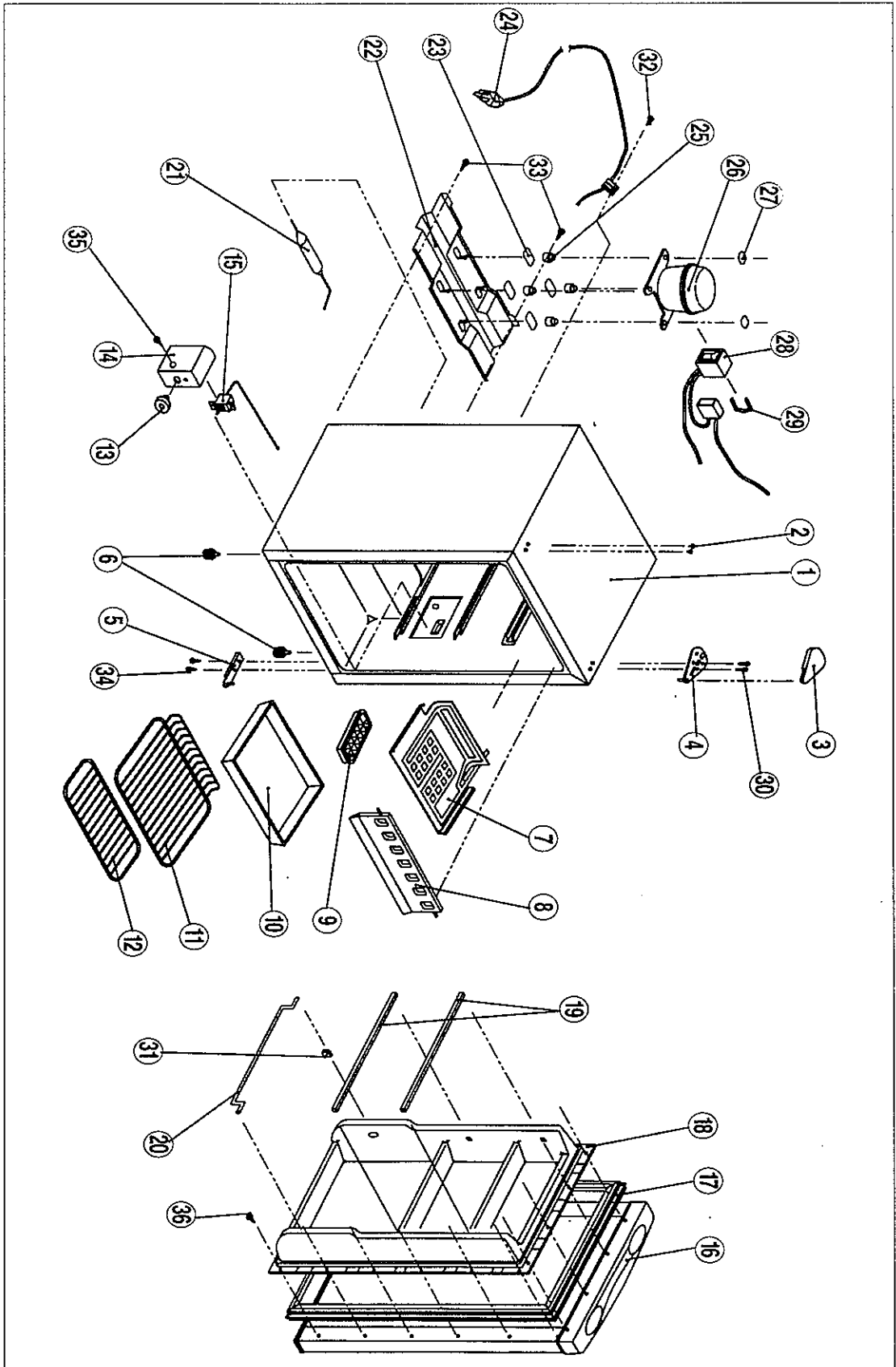

PARTS BREAKDOWN(441YW)

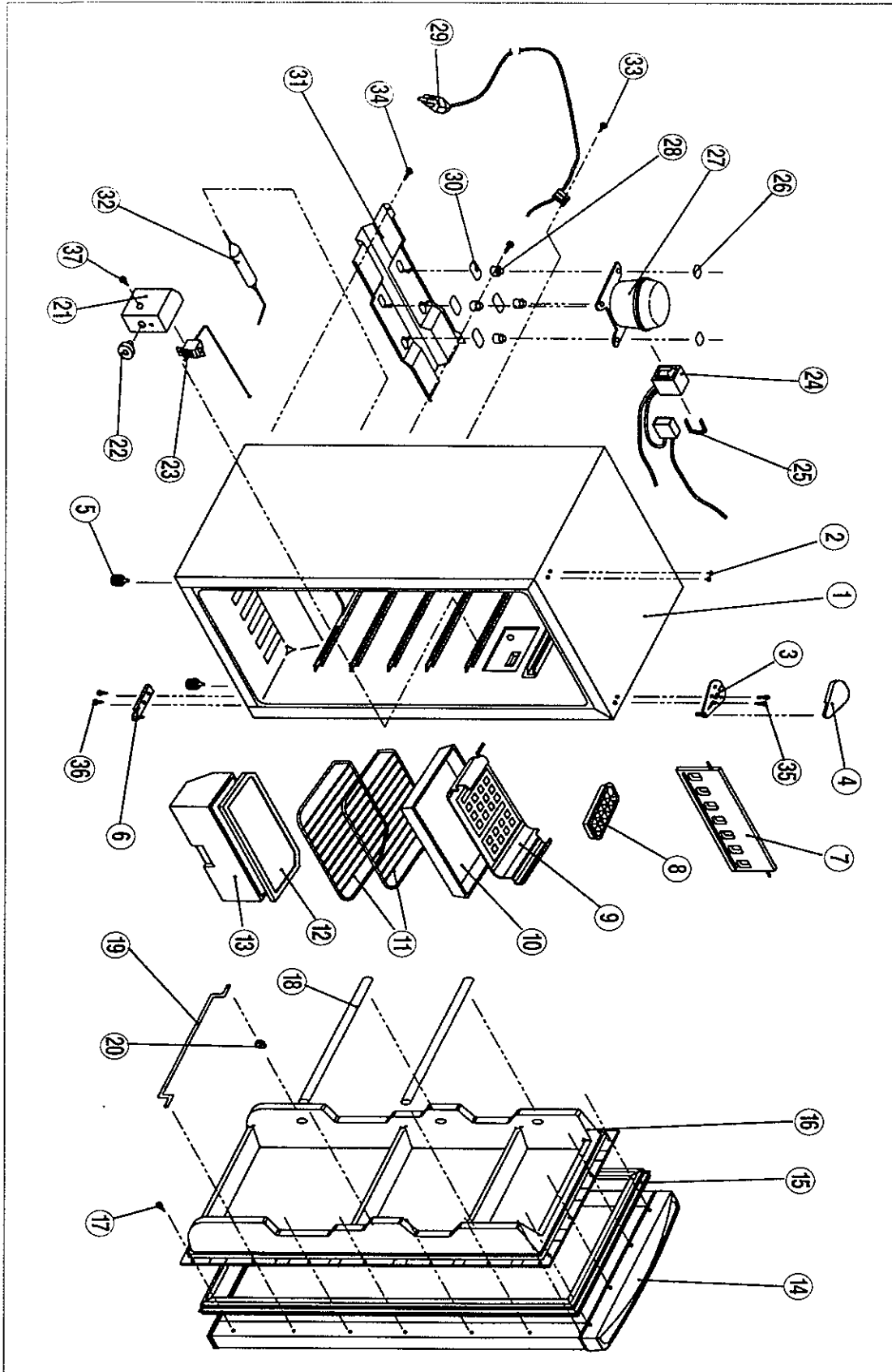

PARTS LIST(18DYW)

NO.	PART CODE	PART NAME	Q'TY	REMARK
1	PFCU00A015	CABINET URETHANE ASSEMBLY	1	
2	3010927900	CABINET HOLE CAP	2	
3	3011409400	TOP HINGE COVER	1	
4	3012910600	TOP HINGE ASSEMBLY	1	
5	3012910500	BOTTOM HINGE ASSEMBLY	1	
6	3012103300	ADJUSTABLE FOOT	2	
7	3011160910	SHELF	1	
8	4002A30420	ICE CUBE TRAY	1	
9	4004D54110	DRIP TRAY FOR DEFROSTING	1	
10	3017000220	EVAPORATOR ASSEMBLY	1	
11	3018301001	THERMOSTAT	1	
12	3010505400	CONTROL BOX	1	
13	4006D70027	CONTROL SWITCH KNOB	1	
14	3016801300	DRYER	1	
15	4016U3302E	COMPRESSOR BASE	1	
16	4001E09021	COMPRESSOR WASHER(BOTTOM)	4	
17	4001E09013	COMPRESSOR ABSORBER	4	
18	4001E09030	COMPRESSOR WASHER(TOP)	4	
19	3951105F10	COMPRESSOR	1	
20	3018108021	RELAY SWITCH ASSEMBLY	1	
21	3816100100	RELAY BAND	1	
22	4006D17101	POWER CORD ASSEMBLY	1	
23	3017408600	DOOR LINER	1	
24	3012302730	DOOR GASKET ASSEMBLY	1	
25	PFRU00A015	DOOR URETHANE ASSEMBLY	1	
26	3019004002	DOOR POCKET BAR (TOP)	1	
27	3019007010	DOOR POCKET BAR (BOTTOM)	1	
28	3011716120	FREEZING COMPARTMENT DOOR	1	
29	7112401011	TAPPING SCREW	1	
30	7122501211	TAPPING SCREW	2	
31	3016000301	MACHINE SCREW	2	
32	7147501411	TAPPING SCREW	2	
33	7112401011	TAPPING SCREW	16	
34	7112402011	TAPPING SCREW	1	

PARTS LIST(271YW)

NO.	PART CODE	PART NAME	Q'TY	REMARK
1	PFCU00B015	CABINET URETHANE ASSEMBLY	1	
2	3010927900	CABINET HOLE CAP	2	
3	3011409400	TOP HINGE COVER	1	
4	3012910600	TOP HINGE ASSEMBLY	1	
5	3012910500	BOTTOM HINGE ASSEMBLY	1	
6	3012103300	ADJUSTABLE FOOT	2	
7	3017000210	EVAPORATOR ASSEMBLY	1	
8	4016V53212	FREEZING COMPARTMENT DOOR	1	
9	4002A30420	ICE CUBE TRAY	1	
10	4004D54110	DRIP TRAY FOR DEFROSTING	2	
11	4016V55112	WIRE SHELF (TOP)	1	
12	4016V55212	WIRE SHELF (BOTTOM)	1	
13	4006D70027	CONTROL SWITCH KNOB	1	
14	3010505400	CONTROL BOX	1	
15	3018301001	THERMOSTAT	1	
16	PFRU00B015	DOOR URETHANE ASSEMBLY	1	
17	3012302720	DOOR GASKET ASSEMBLY	1	
18	3017405600	DOOR LINER	1	
19	3019004810	DOOR POCKET BAR (TOP)	2	
20	3019012120	DOOR POCKET BAR (BOTTOM)	1	
21	3016801300	DRYER	1	
22	4016U3302E	COMPRESSOR BASE	1	
23	4001E09021	COMPRESSOR WASHER(BOTTOM)	4	
24	4006D17101	POWER CORD ASSEMBLY	1	
25	4001E09013	COMPRESSOR ABSORBER	4	
26	3951105F10	COMPRESSOR	1	
27	4001E09030	COMPRESSOR WASHER(TOP)	4	
28	3018116102	RELAY SWITCH ASSEMBLY	1	
29	3816100100	RELAY BAND	1	
30	3016000301	MACHINE SCREW	2	
31	3010702000	BOTTOM VINYL COATED WIRE BAR BUSH	2	
32	7112401011	TAPPING SCREW	1	
33	7122501211	TAPPING SCREW	2	
34	7147501411	TAPPING SCREW	2	
35	7112402011	TAPPING SCREW	1	
36	7112401011	TAPPING SCREW	20	

PARTS LIST(441YW)

NO.	PART CODE	PART NAME	Q'TY	REMARK
1	PFCP00D055	CABINET URETHANE ASSEMBLY	1	
2	3010927900	CABINET HOLE CAP	2	
3	3012910600	TOP HINGE ASSEMBLY	1	
4	3011409400	TOP HINGE COVER	1	
5	3012103300	ADJUSTABLE FOOT	2	
6	3012910500	BOTTOM HINGE ASSEMBLY	1	
7	4017J53213	FREEZING COMPARTMENT DOOR	1	
8	4002A30420	ICE CUBE TRAY	1	
9	3017000202	EVAPORATOR ASSEMBLY	1	
10	4017J54111	DRIP TRAY FOR DEFROSTING	1	
11	4017J55226	WIRE SHELF	2	
12	4018R30411	VEGETABLE CRISPER COVER	1	
13	4017L30612	VEGETABLE CRISPER	1	
14	PFTT00D170	DOOR URETHANE ASSEMBLY	1	
15	3012302631	DOOR GASKET ASSEMBLY	1	
16	3017413400	DOOR LINER	1	
17	7112401011	TAPPING SCREW	22	
18	4017L37132	DOOR POCKET BAR(TOP)	2	
19	3019012100	DOOR POCKET BAR(BOTTOM)	1	
20	3010702000	DOOR POCKET BAR BUSH (BOTTOM)	2	
21	3010505400	CONTROL BOX	1	
22	4006D70027	CONTROL SWITCH KNOB	1	
23	3018301001	THERMOSTAT	1	
24	3018116102	RELAY SWITCH ASSEMBLY	1	
25	3816100100	RELAY BAND	1	
26	4001E09030	COMPRESSOR WASHER(TOP)	4	
27	3951105F10	COMPRESSOR	1	
28	4001E09013	COMPRESSOR ABSORBER	4	
29	4006D17101	POWER CORD ASSEMBLY	1	
30	4001E09021	COMPRESSOR WASHER(BOTTOM)	4	
31	3010309800	COMPRESSOR BASE	1	
32	3016801300	DRYER	1	
33	7112401011	TAPPING SCREW	1	
34	7122501211	TAPPING SCREW	2	
35	3016000301	MACHINE SCREW	2	
36	7147501411	TAPPING SCREW	2	
37	7112402011	TAPPING SCREW	1	

WIRING DIAGRAM

1. 18DYW

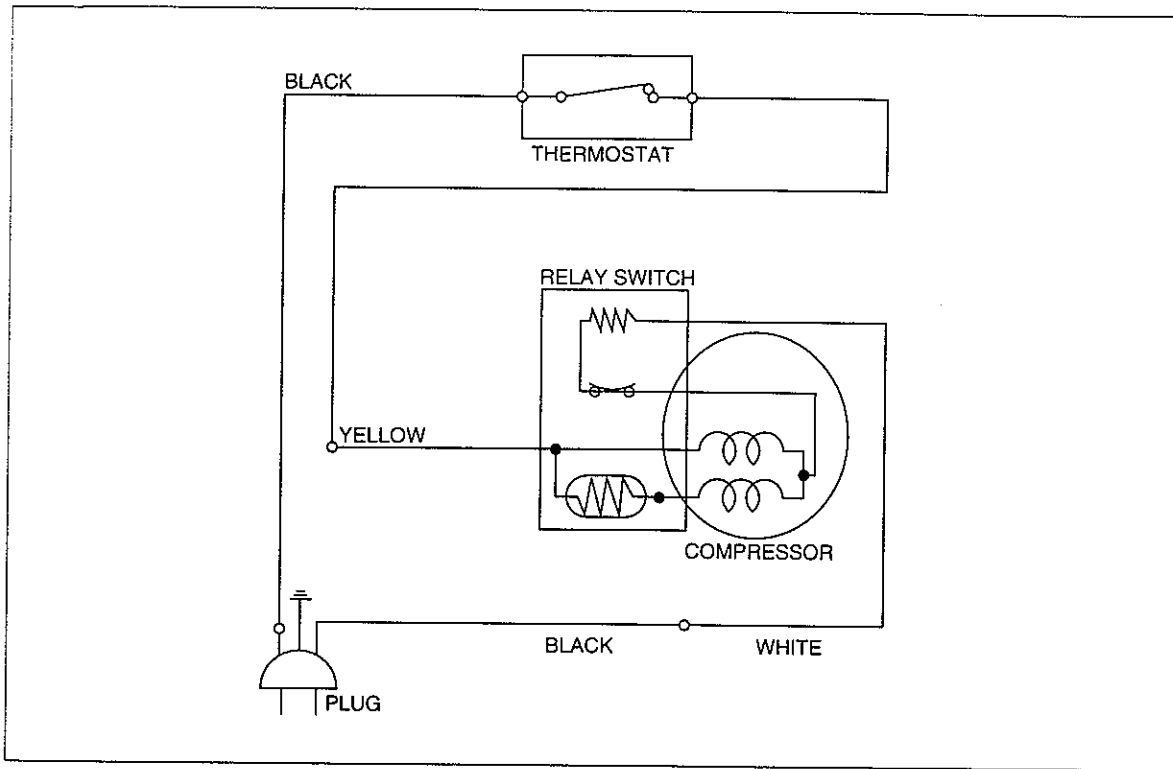

2. 271YW/441YW

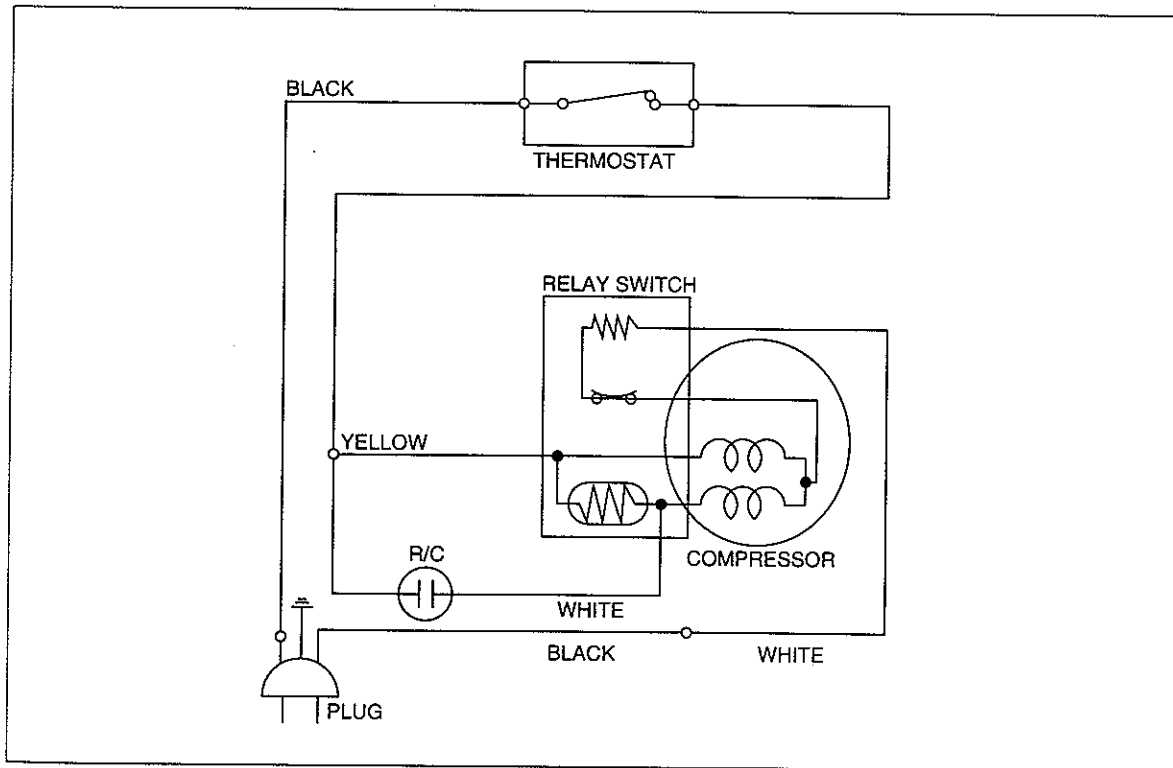

➤ **INSTALACION**

Retire los accesorios de empaque (plásticos protectores, cartón y tiras engomadas). Limpie el exterior con un trapo suave y seco, y el interior con un trapo húmedo y tibio.

➤ **UBICACION**

1. Seleccione un lugar con un piso firme y nivelado.
2. Su refrigerador requiere ventilación. Deje un espacio mínimo de 6" hacia arriba y espacio suficiente en el respaldo para permitir la circulación de aire.
3. Evite luz directa del sol o calor. La luz directa del sol puede afectar la capa de pintura. Las fuentes de calor en su proximidad causarán un consumo mayor de electricidad.
4. Para un mejor desempeño, nivele el refrigerador utilizando las patas ajustables o tornillos niveladores. Para verificar el nivel, abra la puerta hasta la mitad, debe regresar sola.

➤ **INSTRUCCIONES PARA LA CONEXION A TIERRA**

Este aparato electrodoméstico debe estar conectado a tierra. En caso de un cortocircuito eléctrico, la conexión a tierra reduce el riesgo de choque eléctrico proporcionando un cable de escape para la corriente eléctrica. Este aparato viene equipado con un cordón que posee un cable a tierra con un enchufe de conexión a tierra. Este enchufe debe estar conectado en un tomacorriente instalado correctamente y conectado a tierra.

➤ **ADVERTENCIA**

El uso inadecuado del enchufe de conexión a tierra puede resultar en un riesgo de choque eléctrico. Consulte con un electricista si no comprende bien las instrucciones de conexión a tierra o si existe alguna duda sobre si el aparato está conectado a tierra correctamente.

➤ **NO USE UN CORDON DE EXTENSION ELECTRICA**

Use un tomacorriente de pared exclusivo. No conecte su refrigerador a cordones de prolongación eléctrica o junto a cualquier otro electrodoméstico en el mismo tomacorriente de pared.

➤ **ADVERTENCIA IMPORTANTE:**

Un refrigerador vacío es una atracción muy peligrosa para los niños. Quite los sellos magnéticos, puertas o cerraduras de todo electrodoméstico que esté en uso.

➤ **OPERACION**

Enchufe el cable a la toma de corriente, que debe ser 115-120v, 10 AMP ó más. Para evitar vibraciones, la caja debe estar bien nivelada. Para encender el refrigerador, gire el control de temperatura a la posición que corresponda al enfriamiento deseado. Bajo condiciones normales mueva el control a la posición "4". De otra manera ajuste la temperatura siguiendo las indicaciones señaladas en el gráfico que sigue.

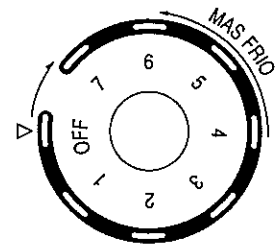

CONTROL DE TEMPERATURA

➤ COMO DESCONGELAR

Coloque el dial del termostato on "OFF" (apagado). Quite todos los alimentos congelados o que se puedan echar a perder. Mantenga la bandeja debajo del congelador como aparece, en la ilustración (modelo 441YW). El descongelado generalmente tarda pocas horas. Para descongelar rápido quite todos los alimentos del refrigerador y deje la puerta abierta. **Nunca use un cuchillo u otro instrumento metálico para rascar el hielo o la escarcha del congelador.** Luego de descongelar, vacíe el agua de la bandeja de goteo y vuelva a colocar el dial del termostato en la posición deseada.

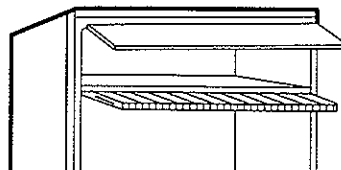

➤ USO DE LAS CUBETERAS DE HIELO

- Llene la cubetera aproximadamente hasta 3/4 de la altura después de lavarla.
- La cubetera es flexible, tuérsela para sacar los hielos.
- Si los cubos de hielo no son usados, pueden disminuir de tamaño y adquirir olores.
- Se aconseja cambiarlos cada 30 días si no se han usado.

➤ CUIDADOS EN LOS PERIODOS DE AUSENCIA

- Para cortos períodos de ausencia (menos de 21 días) el congelador podrá quedar funcionando. Coloque el botón de control de temperaturas en la posición mínima.
- En períodos de ausencia más largos, se aconseja dejar el refrigerador limpio y desconectado.
- Retire todo lo que tenga adentro del refrigerador y haga el deshielo y la limpieza general. También retire las cubeteras, limpie bien y séquelas internamente.
- Deje la puerta entreabierta para que penetre el aire y así evitar la formación de olores.

➤ ECONOMIA DE ENERGIA

- Evite dejar por mucho tiempo la puerta abierta.
- Evite aperturas frecuentes de la puerta.
- Nunca coloque alimentos calientes dentro del refrigerador. Espere que estén a una temperatura ambiental.
- Coloque el botón de control de temperaturas en la posición adecuada.

➤ SI USTED SE VA DE VACACIONES

- Saque todos los artículos del refrigerador-congelador si Ud. se va de vacaciones por un mes o más.
- Desconecte el refrigerador del tomacorriente y limpie el refrigerador bien, incluyendo la bandeja del congelador.
- Deje la puerta abierta para evitar la formación de olores, condensación o moho.

➤ SI USTED SE MUDA

- Desconecte el refrigerador del tomacorriente y limpie el refrigerador bien, incluyendo la bandeja del congelador.
- Saque todas las partes movibles y empaquételas para que no se muevan durante la transportación.
- Cierre la puerta del refrigerador y séllela con cinta adhesiva.
- Asegúrese que el refrigerador va parado durante el viaje y cúbralo con una frazada.

INSTRUCCIONES PARA INVERTIR POSICION DE LA PUERTA

El refrigerador viene equipado con la bisagra colocada en la parte derecha. Si usted desea colocar la puerta en la posición inversa haga lo siguiente:

Desconecte el refrigerador de la pared.

Vacíe el refrigerador completo incluyendo los estantes y toda las comidas, etc.

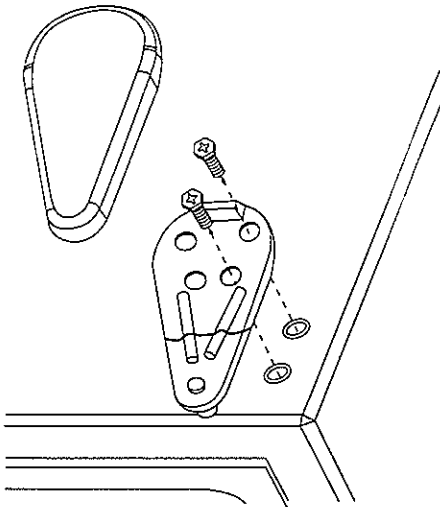
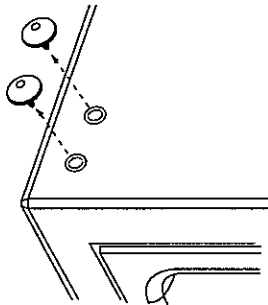
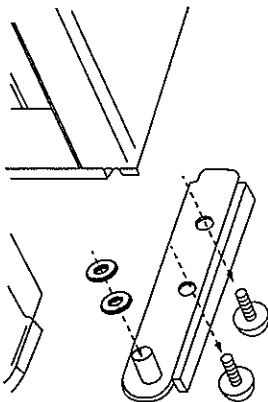
<ol style="list-style-type: none">1. Levante la tapa plástica que cubre la bisagra en la parte superior derecha del gabinete.2. Suelte los dos tornillos (usando una chicharra con un cubo de 8MM) que agarran la bisagra. Guarde los tornillos y las arandelas para utilizarlos nuevamente.3. Levante la bisagra hacia arriba para dejar libre el pin que agarra la parte superior de la puerta.4. Retire la puerta completa, levantándola despacio y colóquela en una superficie suave para que no se dañe.	 A line drawing showing a hand using a screwdriver to remove two screws from a plastic cover on the top right of a refrigerator cabinet. The cover is being lifted away, revealing the hinge mechanism and a pin. The screws and washers are shown being removed and set aside.
<ol style="list-style-type: none">5. Levante las tapas plásticas que cubren los dos huecos en la parte superior izquierda del gabinete y colóquelas en la parte derecha. Presione fuerte hacia abajo las tapas plásticas.	 A line drawing showing the top left corner of the refrigerator cabinet. Two plastic covers are being moved from their original position on the left to their new position on the right. Dashed lines indicate the movement path.
<ol style="list-style-type: none">6. Coloque el gabinete de lado contra el piso. Suelte los dos tornillos que agarran la bisagra inferior al gabinete, usando una chicharra con un cubo de 10MM.	 A line drawing showing the refrigerator cabinet lying on its side on the floor. A hand is using a screwdriver to remove two screws from the bottom hinge. The screws and washers are shown being removed and set aside.

7. Instale la bisagra inferior en la nueva posición a la izquierda utilizando los tornillos retirados en paso número 6.

8. Coloque de nuevo el gabinete en su posición normal.

9. Encaje la puerta en su nueva posición, colocando el pin en el hueco que le corresponde. No se olvide de las arandelas.

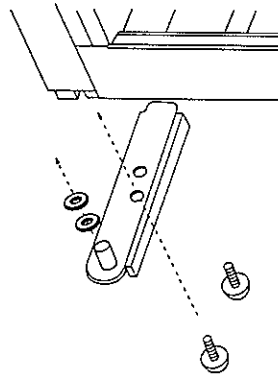

10. Aguantando la puerta en la posición cerrada, asegure la bisagra superior usando los dos tornillos retirados en paso número 2. Antes de atornillarlos fuertemente, esté seguro que la puerta está nivelada con la parte superior del refrigerador. Coloque la tapa plástica que cubre la bisagra.

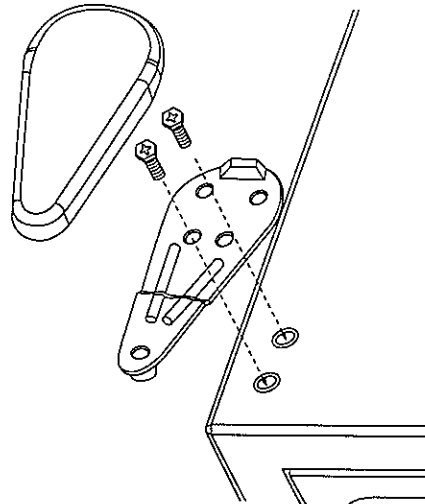

11. Coloque las tapas plásticas en los huecos descubiertos.

