



# WILBUR CURTIS COMPANY, INC.

## Water Boiler, 10 Gallon – Service Manual

### MODELS INCLUDED

- WB-10-12



**CAUTION:** Please use this setup procedure before attempting to use this appliance. Failure to follow the instructions can result in injury or the voiding of the warranty.



**CAUTION:** DO NOT connect this unit to hot water. The inlet valve is not rated for hot water.



**WARNING:** DO NOT place this water boiler closer than six [6] inches from wall. Unit must have adequate cross-ventilation.



**WARNING HOT LIQUID,** Scalding may occur. Avoid splashing.



ISO 9001:2008

WILBUR CURTIS COMPANY  
Montebello, CA 90640

### Important Safeguards/Conventions

This appliance is designed for commercial use. Any servicing other than cleaning and maintenance should be performed by an authorized Wilbur Curtis Company service technician.

- Do Not immerse the unit in water or any other liquid.
- To reduce the risk of fire or electric shock, do not open side or bottom panel. No user serviceable parts inside.
- Keep hands and other items away from hot parts of unit during operation.
- Never clean with scouring powders, bleach or harsh chemicals.

### Symbols:



**WARNINGS – To help avoid personal injury**



**Important Notes/Cautions – from the factory**



**Sanitation Requirements**

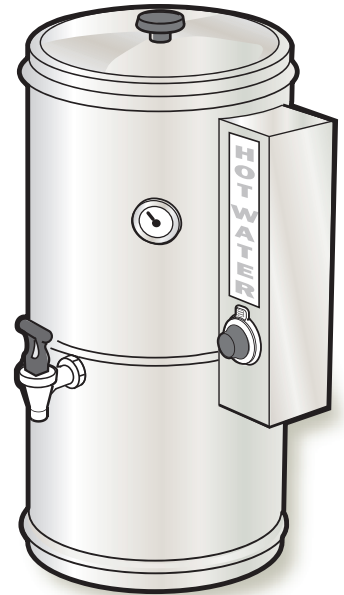

**The Curtis Water Boiler is Factory Pre-Set and Ready to Go... Right from the Carton.**

### Factory Settings:

- Water Temperature = 200°F
- Volume = 10 Gallons

### System Requirements

- Water Source: 20 – 100PSI (Min Flow Rate of 1 GPM)
- Electrical: See electrical schematic.



NSF International requires the following water connection:

1. A quick disconnect or additional coiled tubing (at least 2x the depth of the unit) so that the machine can be moved for cleaning underneath.
2. This equipment is to be installed with adequate backflow protection to comply with applicable federal, state and local codes..
3. Water pipe connections and fixtures directly connected to a potable water supply shall be sized, installed and maintained in accordance with federal, state, and local codes.

### SETUP STEPS

1. Place unit at counter height. on a firm, level base, in such a way that it can be connected to water and power supply.
2. Install the supplied water faucet on the faucet shank in front of the unit.
3. Connect water line to inlet fitting on valve. It is recommended that some type of water mineral reducing filter be used in the water line before entering the unit. Water pressure entering boiler is must be stable and provide minimum of 1 gallon per minute. Use water regulator for constant pressure. Required water pressures, 20 to 100 psi. Turn on water valve.
5. Hook-up power to the unit (refer to schematic for power requirements).
6. Turn on the circuit running power to unit. The water inlet valve will open, filling the unit. When the boiler has filled, turn on boiler at the thermostat, twisting the knob clockwise.
7. Heating tank will require 50 to 60 minutes to attain operating temperature. Thermostat indicator will light at this time.

# Illustrated Parts List

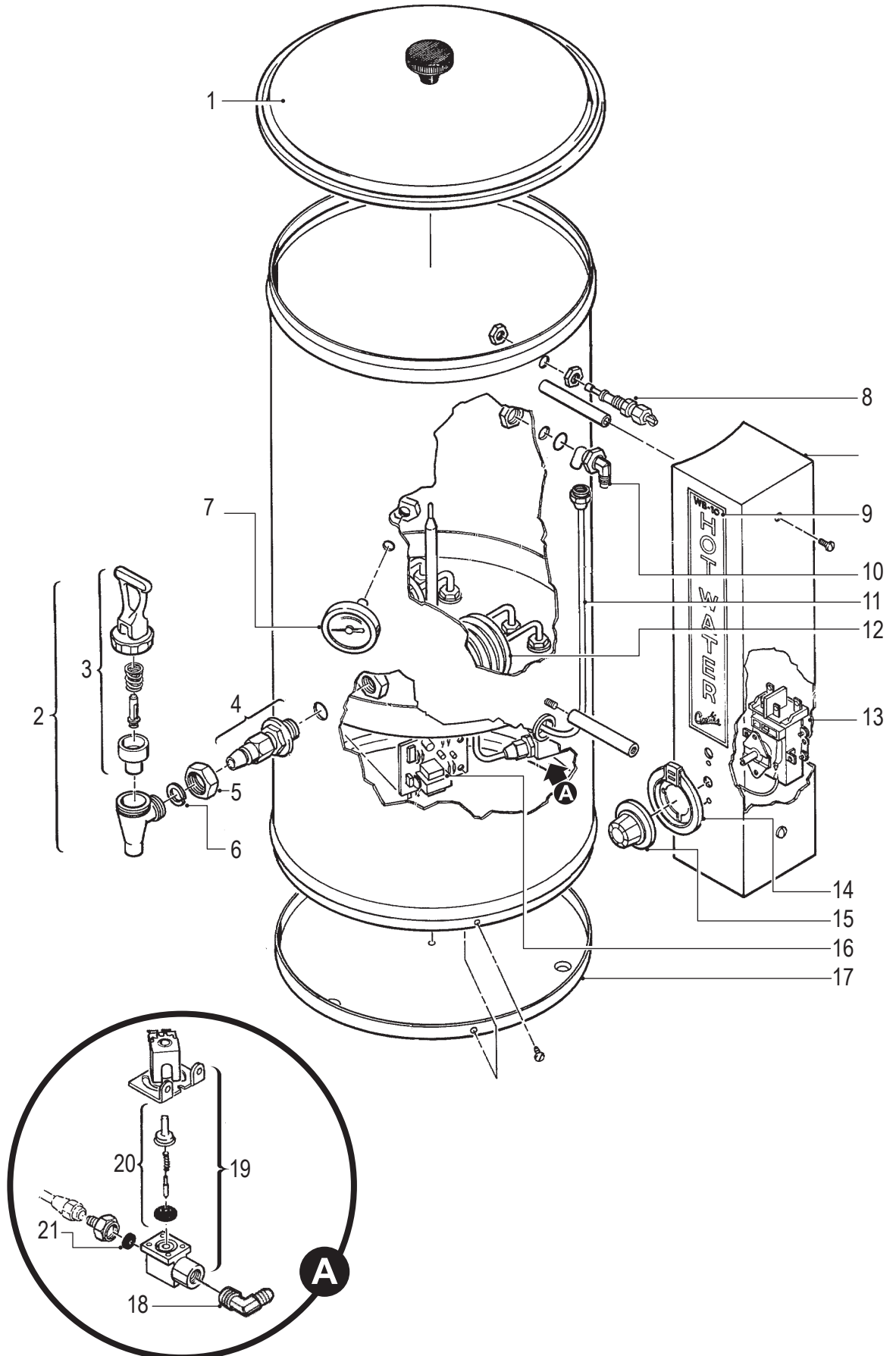

## Parts List

INDEX Nº	PART Nº	DESCRIPTION
1	WC-5602	LID WITH KNOB
2	WC-1800HW	FAUCET, "S" SERIES HOT WATER 1-1/32-14 UNS
3	WC-3705HW	KIT, FAUCET S SERIES HOT WATER
4	WC-1902	SHANK, FAUCET PLAIN W/NUTS
5	WC-1903	NUT, UNION SHANK WB-10
6	WC-1906	"C" RING .917 X .760 X .090
7	WC- 511	THERMOMETER, DIAL RU'S
8	WC-5502	PROBE, WATER LEVEL
9	WC-3914	LABEL, "HOT WATER" (WB-10)
10	WC-2966	FITTING, WATER INLET WB-10
11	WC-5386	TUBING ASSEMBLY, WATER INLET
12	WC- 922-04	ELEMENT, HEATING 3.5KW 220V W/NUTS & WSHRS
13	WC-37136	KIT, THERMOSTAT WB-10-12
14	WC-3220	BEZEL, THERMOSTAT ELECTRIC
15	WC-3217	KNOB, ELECTRIC THERMOSTAT
16	WC- 608	LEVEL CONTROL, WATER 120V
17	WC-5611	COVER, BOTTOM WB-10
18	WC-2401	ELBOW, 3/8 NPT X 1/4 FLRE PLTD
19	WC- 801	VALVE, INLET BRASS .50 GPM 120V 10W RU/WB
20	WC-3700	KIT, INLET VALVE REPAIR
21	WC- 813	FLOW WASHER, .5GPM .5" S45

## Electric Thermostat Adjustment

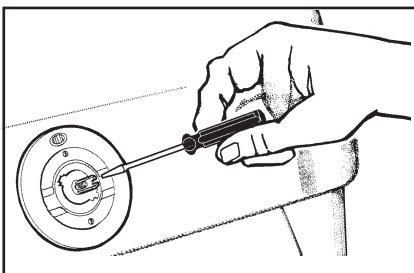

### ELECTRIC THERMOSTAT ADJUSTMENT

On electric water boilers, thermostats are set at the factory to cut off at 200°F. We do not recommend changing this. If necessary, adjustment is as follows:

1. Rotate the thermostat knob to the right to the BOIL position. Pull off the knob.
2. Locate the tiny adjustment screw, inside the stem (see figure 1). Using a small screwdriver, adjust the temperature up or down:
  - a. By turning the screw ¼ turn to the left will increase the temperature about 20°F.
  - b. Turning ¼ to the right will decrease the temperature by 20°F.
  - c. To set the thermostat precisely at 200°F, insert a thermometer probe into the water jacket through the steam hole (just under the sprayhead). Turn the screw ½ turn to the left.
  - d. When the thermometer reaches 200°F, slowly turn the adjustment screw to the right until the pilot light turns off.

# TROUBLE SHOOTING

## PROBLEM: WATER WILL NOT REFILL

POSSIBLE CAUSE	SOLUTION
1. Water line closed or clogged filter	Check the water system at your facility to make sure the line is open. Replace the water filter.
2. Valve coil burned out	Turn machine off. Disconnect wires from water inlet coil terminals and connect a power cord to the terminals. Plug cord into a 120V outlet and verify if water flows when plugged in and stops when power is disconnected. If valve fails this test, replace valve.
3. Grounded probe	When the water level gets below the probe tip, water should automatically refill the unit. If not, pull wire off the probe terminal. Water should now start flowing into the water boiler.
4. Defective water level control board	Disconnect wire from probe terminal. With a voltmeter, check voltage at the water inlet coil terminals. This should read 110-120 volts. If no voltage is present, check liquid level control (L.L.C.) board. Make sure the L.L.C. board is supplied by 120V across terminals T2 & T3. The L.L.C. board is grounded to the body of the machine by contacting the board to the mounting bracket. Make sure board is grounded here. Check for loose connections at terminals. Replace board.

## PROBLEM: WATER OVERFLOWING.

POSSIBLE CAUSE	SOLUTION
1. Defective water inlet valve	Turn power off and observe water level. If water continues to flow into the heating tank, clean or replace leaky valve.
2. Liquid level probe limed up	Disconnect wire from probe terminal. Touch the body of the heating tank with the terminal at the end of this wire. If the flow of water stops, try cleaning the probe. The probe may have to be replaced.
3. Non-grounded or loose terminal connections at liquid level control board	Liquid level control board must be securely grounded through the back of the board and the mounting bracket. Check for loose connections at the terminals. Check for voltage across the inlet valve terminals. If there is 110 to 120 volts present at the inlet valve terminals when water level is touching the probe tip, replace the L.L.C. board.

## PROBLEM: WATER DOES NOT REACH PROPER TEMPERATURE

POSSIBLE CAUSE	SOLUTION
1. Thermostat is turned OFF (or set too low)	Check the thermostat adjustment to make sure the knob is rotated clockwise to the desired temperature setting.

## PROBLEM: WATER OVERHEATS, ELEMENTS DO NOT SHUT OFF

POSSIBLE CAUSE	SOLUTION
1. Defective thermostat	Replace the thermostat. You can sometimes operate temporarily by turning the thermostat knob to off until the boiling stops.

# TROUBLE SHOOTING CONTINUED:

**PROBLEM:** WATER DOES NOT REACH PROPER TEMPERATURE

POSSIBLE CAUSE	SOLUTION
2. Defective thermostat	Replace thermostat if contacts are open when knob is fully clockwise and water temperature is less than 190° F. You will measure 120 volts (approximately) to ground from both thermostat terminals when it is ON and from only one terminal when it is OFF.
3. Heating element burned out.	<p>In this water boiler there are two elements in parallel. Failure of either will cause very slow heating. Perform the following tests:</p> <p>a. Clamp-on ammeter test: If both elements are good, you will measure about 21 amps at 240 volts, 24 amps at 208 volts or 29 amps at 120 volts. If you measure only 10 to 12 amps, check the current to each element to identify the defective part.</p> <p>b. Ohmmeter or continuity test: Disconnect all power by unplugging unit. Disconnect one terminal to measure each element. They should each have continuity or measure about 20 ohms.</p>

## ELECTRICAL SCHEMATIC DUAL VOLTAGE 120V/220V

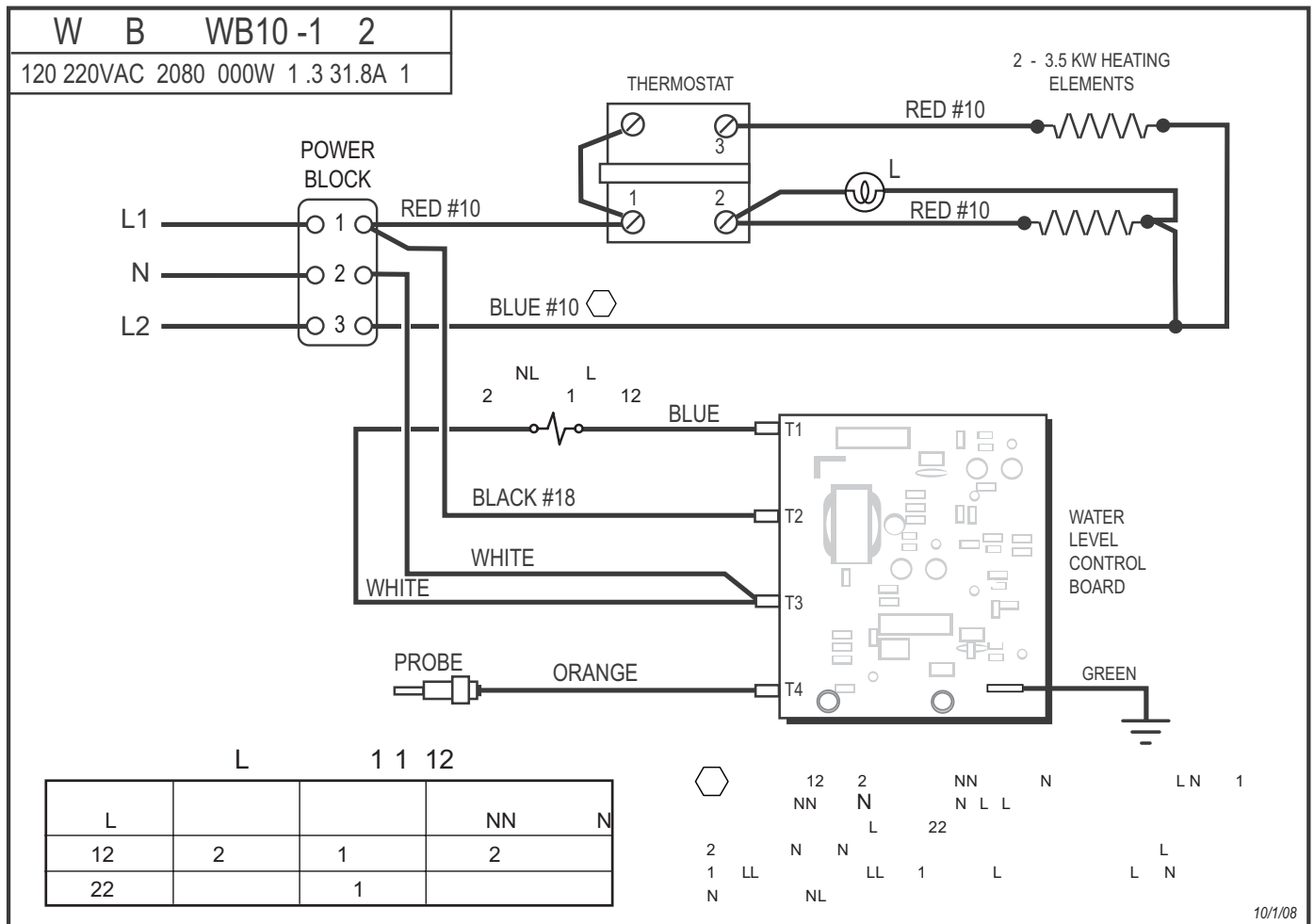

# ELECTRICAL SCHEMATIC 220V

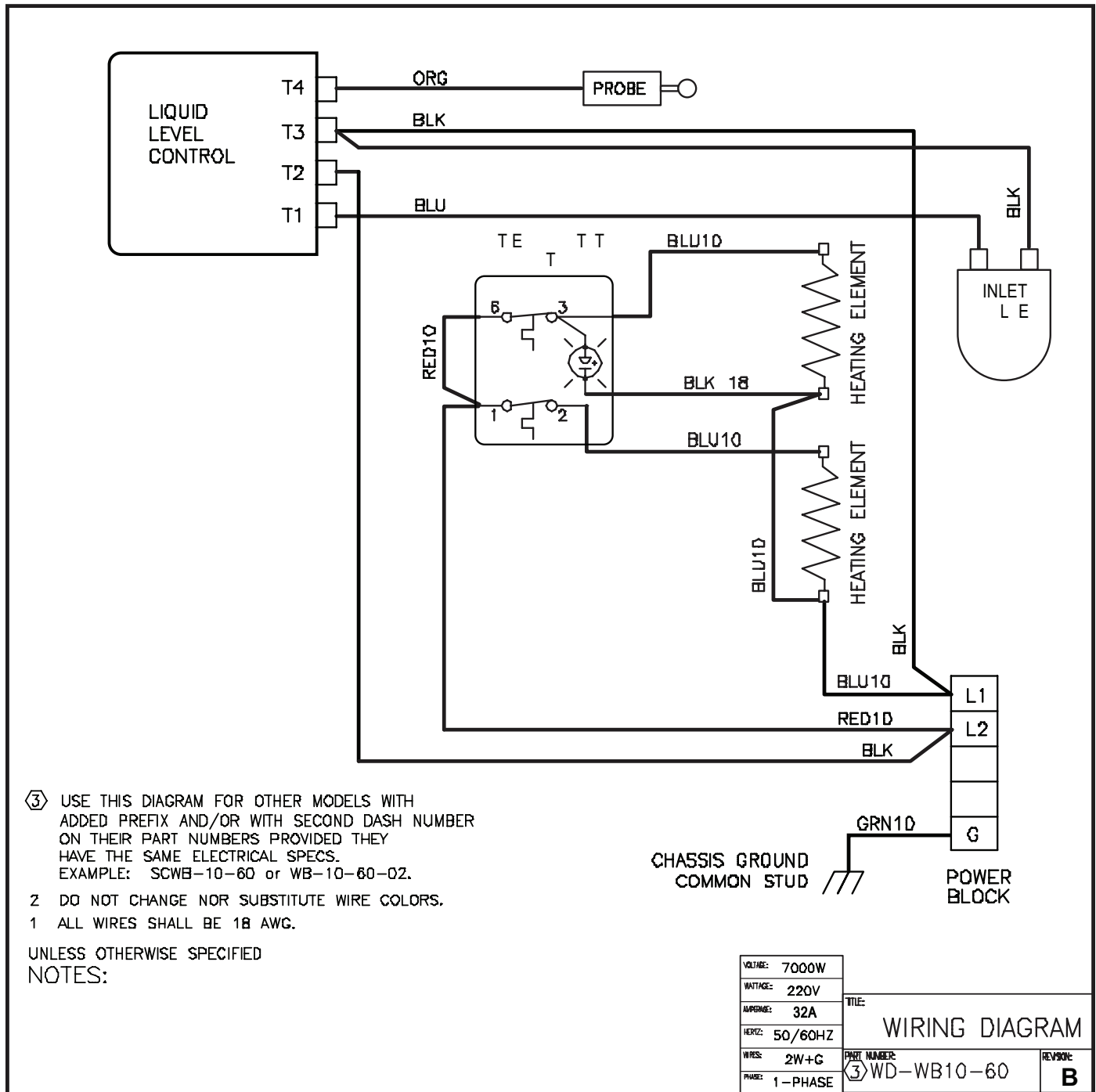

***This page intentionally left blank.***

## Product Warranty Information

The Wilbur Curtis Company certifies that its products are free from defects in material and workmanship under normal use. The following limited warranties and conditions apply:

- 3 Years, Parts and Labor, from Original Date of Purchase on digital control boards.
- 2 Years, Parts, from Original Date of Purchase on all other electrical components, fittings and tubing.
- 1 Year, Labor, from Original Date of Purchase on all electrical components, fittings and tubing.

Additionally, the Wilbur Curtis Company warrants its Grinding Burrs for Forty (40) months from date of purchase or 40,000 pounds of coffee, whichever comes first. Stainless Steel components are warranted for two (2) years from date of purchase against leaking or pitting and replacement parts are warranted for ninety (90) days from date of purchase or for the remainder of the limited warranty period of the equipment in which the component is installed.

All in-warranty service calls must have prior authorization. For Authorization, call the Technical Support Department at 1-800-995-0417. Effective date of this policy is April 1, 2003.

Additional conditions may apply. Go to [www.wilburcurtis.com](http://www.wilburcurtis.com) to view the full product warranty information.

### CONDITIONS & EXCEPTIONS

The warranty covers original equipment at time of purchase only. The Wilbur Curtis Company, Inc., assumes no responsibility for substitute replacement parts installed on Curtis equipment that have not been purchased from the Wilbur Curtis Company, Inc. The Wilbur Curtis Company will not accept any responsibility if the following conditions are not met. The warranty does not cover and is void under the following circumstances:

- 1) **Improper operation of equipment:** *The equipment must be used for its designed and intended purpose and function.*
- 2) **Improper installation of equipment:** *This equipment must be installed by a professional technician and must comply with all local electrical, mechanical and plumbing codes.*
- 3) **Improper voltage:** *Equipment must be installed at the voltage stated on the serial plate supplied with this equipment.*
- 4) **Improper water supply:** *This includes, but is not limited to, excessive or low water pressure, and inadequate or fluctuating water flow rate.*
- 5) **Adjustments and cleaning:** *The resetting of safety thermostats and circuit breakers, programming and temperature adjustments are the responsibility of the equipment owner. The owner is responsible for proper cleaning and regular maintenance of this equipment.*
- 6) **Damaged in transit:** *Equipment damaged in transit is the responsibility of the freight company and a claim should be made with the carrier.*
- 7) **Abuse or neglect (including failure to periodically clean or remove lime accumulations):** *Manufacturer is not responsible for variation in equipment operation due to excessive lime or local water conditions. The equipment must be maintained according to the manufacturer's recommendations.*
- 8) **Replacement of items subject to normal use and wear:** *This shall include, but is not limited to, light bulbs, shear disks, "O" rings, gaskets, silicone tube, canister assemblies, whipper chambers and plates, mixing bowls, agitation assemblies and whipper propellers.*
- 9) **Repairs and/or Replacements** *are subject to our decision that the workmanship or parts were faulty and the defects showed up under normal use. All labor shall be performed during regular working hours. Overtime charges are the responsibility of the owner. Charges incurred by delays, waiting time, or operating restrictions that hinder the service technician's ability to perform service is the responsibility of the owner of the equipment. This includes institutional and correctional facilities. The Wilbur Curtis Company will allow up to 100 miles, round trip, per in-warranty service call.*

**RETURN MERCHANDISE AUTHORIZATION:** *All claims under this warranty must be submitted to the Wilbur Curtis Company Technical Support Department prior to performing any repair work or return of this equipment to the factory. All returned equipment must be repackaged properly in the original carton. No units will be accepted if they are damaged in transit due to improper packaging. **NO UNITS OR PARTS WILL BE ACCEPTED WITHOUT A RETURN MERCHANDISE AUTHORIZATION (RMA). RMA NUMBER MUST BE MARKED ON THE CARTON OR SHIPPING LABEL.** All in-warranty service calls must be performed by an authorized service agent. Call the Wilbur Curtis Technical Support Department to find an agent near you.*



WILBUR CURTIS CO., INC.

6913 Acco St., Montebello, CA 90640-5403 USA

Phone: 800/421-6150 ♦ Fax: 323-837-2410

♦ Technical Support Phone: 800/995-0417 (M-F 5:30A - 4:00P PST) ♦ E-Mail: [techsupport@wilburcurtis.com](mailto:techsupport@wilburcurtis.com)

♦ Web Site: [www.wilburcurtis.com](http://www.wilburcurtis.com)

**FOR THE LATEST SPECIFICATION INFORMATION GO TO [WWW.WILBURCURTIS.COM](http://WWW.WILBURCURTIS.COM)**