



Please refer to the Lancer web site (www.lancercorp.com) for information relating to Lancer Installation and Service Manuals, Instruction Sheets, Technical Bulletins, Service Bulletins, etc.

INSTALLATION AND SERVICE MANUAL

LANCER SERIES 4500

IBD25

<u>PART NO.</u>	<u>DESCRIPTION</u>
85-4528H	ICE BEVERAGE DISPENSER, 25 INCH WIDE, 8V, 115V/60Hz
85-4538H	ICE BEVERAGE DISPENSER, 25 INCH WIDE, 8V, 230V/50-60Hz
85-4425H	ICE DISPENSER, 25 INCH WIDE, 115V/60Hz
85-4435H	ICE DISPENSER, 25 INCH WIDE, 230V/50-60Hz

SPECIFICATIONS

DIMENSIONS

HEIGHT:	34.0 Inches	(864 mm)
WIDTH:	25.0 Inches	(635 mm)
DEPTH:	30.5 Inches	(775 mm)

TOTAL ICE CAPACITY:	210 Pounds	(95.45 kg)
DISPENSABLE ICE CAPACITY:	170 Pounds	(77.27 kg)
COUNTER WEIGHT (WITHOUT ICE):	250 Pounds	(113.64 kg)
SHIPPING WEIGHT:	285 Pounds	(129.55 kg)

ELECTRICAL

VOLTAGE:	<u>115</u>	<u>230</u>
AMPS:	3.6	1.8
Hz:	60	50/60



WARNING

THIS UNIT IS EQUIPPED WITH AUTOMATIC AGITATION. IT MAY ACTIVATE UNEXPECTEDLY. DO NOT PLACE HANDS, OR FOREIGN OBJECTS IN THE ICE STORAGE COMPARTMENT.

WHEN UNIT IS BEING SERVICED, CLEANED, OR SANITIZED, UNPLUG DISPENSER FROM THE POWER SOURCE.

NOTE

Lancer does not recommend the use of shaved, flake, nugget, or pellet ice in the dispenser. Dispenser will only operate with cube ice.

This manual supersedes Installation and Service Manual 28-0417/01, Dated 03/10/04, and is being published on the Lancer Web Site only.



6655 LANCER BLVD. • SAN ANTONIO, TEXAS 78219 USA • (210) 310-7000

FAX SALES

- NORTH AMERICA – 210-310-7245 • INTERNATIONAL SALES – 210-310-7242 • CUSTOMER SERVICE – 210-310-7242 •
- LATIN AMERICA – 210-310-7245 • EUROPE – 32-2-755-2399 • PACIFIC – 61-8-8268-1978 •
- FAX ENGINEERING: • 210-310-7096 •

- "Lancer" is the registered trademark of Lancer •
- Copyright — 2006 by Lancer, all rights reserved. •

DATE: 02/15/06
P.N. 28-0417/02

TABLE OF CONTENTS

SPECIFICATIONS.....	Cover
TABLE OF CONTENTS	1
1. INSTALLATION	1
1.1 RECEIVING.....	1
1.2 UNPACKING	1
1.3 SELECTING COUNTER LOCATION.....	1
1.4 INSTALLING THE DISPENSER.....	2
1.5 ADJUSTING THE ICE FLOW REGULATOR (230 VOLT UNITS ONLY).....	3
2. CLEANING AND SANITIZING INSTRUCTIONS	4
2.1 GENERAL INFORMATION	3
2.2 REQUIRED CLEANING EQUIPMENT.....	4
2.3 DAILY CLEANING	5
2.4 ICE BIN CLEANING – START UP AND MONTHLY	4
2.5 CLEANING AND SANITIZING BEVERAGE COMPONENTS - FIGAL SYSTEMS.....	4
2.6 CLEANING AND SANITIZING BEVERAGE COMPONENTS - BAG-IN-BOX SYSTEMS.....	6
3. TROUBLESHOOTING.....	6
3.1 PUSH CHUTE AND NOTHING HAPPENS.....	7
3.2 PUSH CHUTE, TRAP DOOR OPENS BUT MOTOR DOES NOT RUN	7
3.3 PUSH CHUTE, MOTOR RUNS BUT TRAP DOOR DOES NOT OPEN	7
3.4 PUSH CHUTE, TRAP DOOR OPENS, MOTOR RUNS, BUT NO ICE DISPENSES.....	7
3.5 VALVES DO NOT OPERATE	6
3.6 WATER IN ICE BIN	7
4. LIGHT EMITTING DIODES	6
5. AUTOMATIC AGITATION AND LOW ICE ALARM CONTROL.....	8
6. ILLUSTRATIONS, PARTS LISTINGS, AND WIRING DIAGRAMS, IBD25.....	9
6.1 DECALS AND LABELS, IBD25.....	9-10
6.2 PLUMBING DIAGRAM.....	10
6.3 FINAL ASSEMBLY, POST-MIX IBD AND ICE DISPENSER, IBD25.....	11-12
6.4 FAUCET PLATE AND ICE CHUTE SUB-ASSEMBLY, POST-MIX, IBD25	13-14
6.5 ELECTRICAL BOX AND GEAR MOTOR SUB-ASSEMBLY, POST-MIX, IBD25.....	15-16
6.6 WIRING DIAGRAM - 115V/60HZ, SERIES 4500 IBD	17
6.7 WIRING DIAGRAM - 230V/50-60HZ, SERIES 4500 IBD	18
6.8 AGITATION - CONTROLS, EXPANDED VIEW	19

1. INSTALLATION

1.1 RECEIVING

Each unit is completely tested under operating conditions and thoroughly inspected before shipment. At time of shipment the carrier accepts the unit, and any claim for damage must be made with the carrier. Upon receiving units from the delivering carrier, carefully inspect carton for visible indication of damage. If damage exists, have carrier note same on bill of lading and file claim with carrier.

1.2 UNPACKING

- A. Set shipping carton upright on the floor.
- B. Cut band and remove.
- C. Open top of carton and remove interior packing.
- D. Lift carton up and off of the dispenser.
- E. Remove wood shipping base from the bottom of the dispenser. (Support dispenser while removing shipping base to prevent damage to the dispenser.)

1.3 SELECTING COUNTER LOCATION

WARNING

THIS APPLIANCE MUST BE EARTHED. THIS DISPENSER MUST BE ELECTRICALLY GROUNDED TO AVOID DANGER TO THE OPERATOR. THE POWER CORD PROVIDED HAS A THREE PRONG GROUNDED PLUG. IF A THREE HOLE GROUNDED ELECTRICAL OUTLET IS NOT AVAILABLE, USE AN APPROVED METHOD OF INSURING A PROPER GROUND TO THE DISPENSER.

- A. Select a location close to a properly grounded electrical outlet, convenient to an open type drain, and access for soda, water, and syrup lines.

1. If at all possible, location should be away from direct sunlight or other heat sources.
 2. Connecting lines may be run through access in back of the unit or extend down through a counter cut out.
 3. The counter must support the weight of the dispenser, ice, and possibly an ice maker. Total weight may exceed 800 pounds (363.6 kg).
- B. Unit may be installed directly on the countertop or on legs supplied with the unit. If installed directly on the counter, the unit must be sealed to the countertop. ***If an ice maker is to be mounted on top of dispenser, do not install dispenser on legs.***

NOTE

Water pipe connections and fixtures directly connected to a potable water supply must all be sized, installed, and maintained according to Federal, State, and Local laws.

The water supply **must** be protected by means of an air gap, a backflow prevention device (located upstream of the CO₂ injection system) or another approved method to comply with NSF standards. A backflow prevention device must comply with ASSE and local standards. *It is the responsibility of the installer to ensure compliance.*

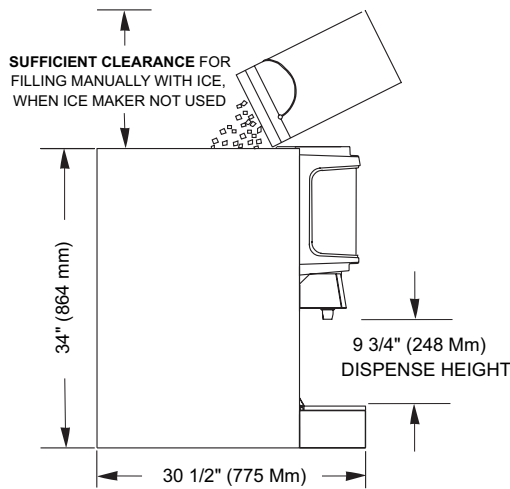

NOTE:
Please refer to specific icemaker model for proper air intake/exhaust ventilation with Lancer units.

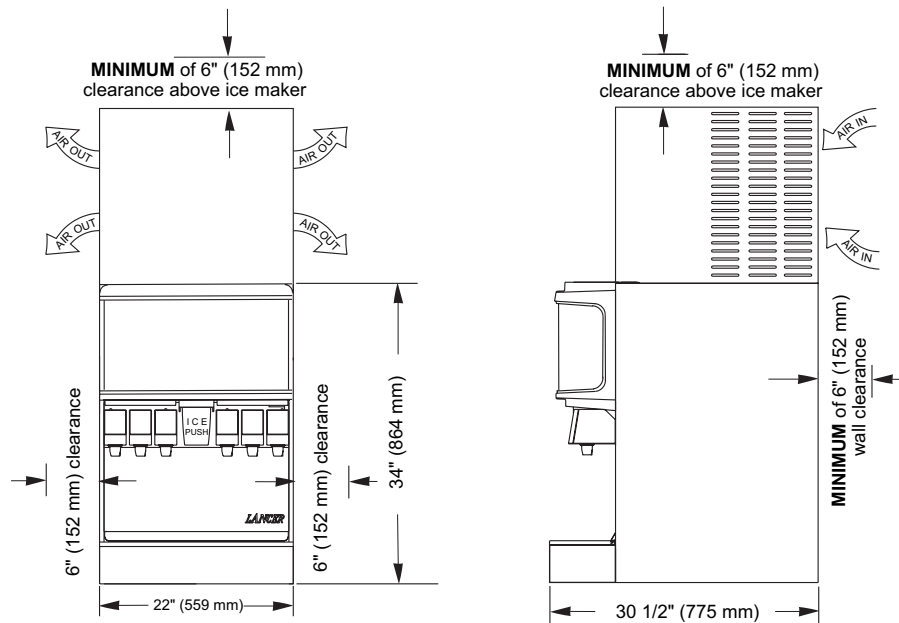

Figure 1

- C. Location must insure sufficient clearance on sides, top and back of unit is provided for ventilation and air circulation (see Figure 1).
- D. Additionally, if an ice maker is not top mounted on the unit, sufficient clearance should be provided [a minimum of 16 inches (406 mm) is recommended] to allow filling the unit with ice

from a five (5) gallon (19 liter) container (see Figure 1).

1.4 INSTALLING THE DISPENSER

- A. Remove Cup Rest, Drip Tray, Splash Plate, and Top Cover.
- B. Remove Cover Plate at rear of unit if not a through the counter installation.
- C. Connect soda and water supply lines to 3/8 inch barb fittings at the front of the unit. Check for leaks. (If dispenser is to operate with all soda valves, connect water line into one of the soda supply lines.)
- D. Connect syrup supply lines to the 3/8 inch barb inlet fittings at the front of the unit. Check for leaks.
- E. Uncoil drain hose from Cold Plate drain and extend to an open type drain.
- F. Install Drip Tray and extend hose to open type drain.
- G. Both drain lines must be insulated with a closed cell insulation. Insulation must cover the entire length of the drain hose, including fittings. The drain should be installed in such a manner that water does not collect in sags or other low points, as condensation will form.
- H. Install Cup Rest and Splash Plate.
- I. Connect Power Cord to grounded electrical outlet.
- J. Test Motor operation by pushing Ice Chute.
- K. Clean and sanitize dispenser (see Section 2).
- L. Fill unit approximately half full with ice. Push Chute and check for ice delivery.
- M. Finish filling unit with ice.
- N. Install Top Cover.

NOTE

Lancer does not recommend the use of shaved, flake, nugget, or pellet ice in the dispenser. Dispenser will only operate with cube ice.

- O. Set brix ratio for beverage dispensing valves according to manufacturer's instructions.

IMPORTANT NOTICE

WHEN INSTALLING AN ICEMAKER ON AN IBD UNIT, A BIN THERMOSTAT OR OTHER MEANS OF CONTROLLING THE ICE LEVEL MUST BE INSTALLED. FAILURE TO DO SO COULD RESULT IN DAMAGE TO THE DISPENSING MECHANISM AND VOID THE WARRANTY.

DURING THE AUTOMATIC AGITATION CYCLE AND/OR WHILE DISPENSING ICE, THERE MUST BE ADEQUATE ROOM BETWEEN THE TOP OF THE ICE LEVEL AND THE BOTTOM OF THE ICEMAKER SO THAT THE ICE CAN MOVE WITHOUT OBSTRUCTION.

CONTACT YOUR ICEMAKER SUPPLIER FOR INFORMATION ON PROPER BIN THERMOSTAT.

1.5 ADJUSTING THE ICE FLOW REGULATOR (230 VOLT UNITS ONLY) (SEE FIGURE 2)

*The Regulator Door Assembly (PN 82-2904) can regulate the dispensed ice flow. Installation of an Ice Flow Regulator is **NOT** necessary for the dispensing of ice. This IBD unit will dispense ice unrestricted.*

- A. Remove Bin Lids.
- B. Adjust Ice Regulator to desired position by turning the nut screw clockwise to close, or counter clockwise to open, with the use of a nut driver or a socket wrench (see Figure 2).

NOTE

Total adjustment: 1/2 inch.

- C. Reinstall bin lids.

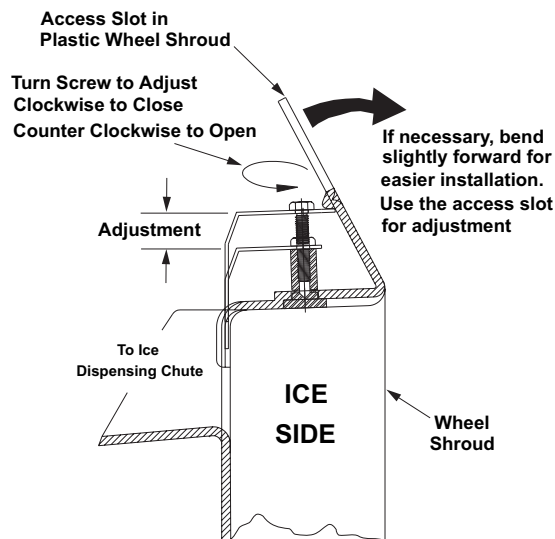

CUT AWAY VIEW
Figure 2

2. CLEANING AND SANITIZING INSTRUCTIONS

2.1 GENERAL INFORMATION

- A. Lancer equipment (new or reconditioned) is shipped from the factory cleaned and sanitized in accordance with NSF guidelines. This equipment must be cleaned and sanitized after installation is complete, and the operator of the equipment must provide continuous maintenance as required by this manual and/or state and local health department guidelines to ensure proper operation and sanitation requirements are maintained.

NOTE

The cleaning and sanitizing procedures provided herein pertain to the Lancer equipment identified by this manual. If other equipment is being cleaned, follow the guidelines established for that equipment.

- B. Cleaning and sanitizing should be accomplished only by trained personnel. Sanitary gloves are to be used during cleaning and sanitizing operations. Applicable safety precautions must be observed. Instruction warnings on the product being used must be followed.
- C. Water lines are not to be disconnected during the cleaning and sanitizing of syrup lines to avoid contamination.
- D. Do **NOT** use strong bleaches or detergents. They tend to discolor and/or corrode various materials.
- E. Do **NOT** use metal scrapers, sharp objects, steel wool, scouring pads, abrasives, solvents, etc., on the dispenser.
- F. Do **NOT** use hot water above 140°F (60°C). This may damage certain materials.

2.2 REQUIRED CLEANING EQUIPMENT

- A. Cleansers (for example, Ivory Liquid, Calgon, etc.) mixed with clean, potable water at a temperature of 90 to 110 degrees Fahrenheit should be used to clean equipment. The mixture ratio, using Ivory Liquid, is one (1) ounce of cleanser to two (2) gallons of water. A minimum of five (5) gallons of cleaning mixture should be prepared. Any equivalent cleanser may be used as long as it provides a caustic based, non-perfumed, easily rinsed mixture containing at least two (2) percent sodium hydroxide (NaOH). Rinsing must be thorough and use clean, potable water which is also at a temperature of 90° to 110°F.

NOTE

Extended lengths of product lines may require that an additional volume of cleaning solution be prepared.

- B. Sanitizing solutions should be prepared in accordance with the manufacturer's written recommendations and safety guidelines. The solution must provide 200 parts per million (PPM) available chlorine. A minimum of five (5) gallons of sanitizing solution should be prepared. Any sanitizing solution may be used as long as it is prepared in accordance with the manufacturer's written recommendations and safety guidelines, and provides 200 parts per million (PPM) available chlorine. Sanitizing solution is to be purged from line(s) and equipment by flushing with product only until there is no after taste. *Do not rinse with water.*

NOTE

Please note that a fresh water rinse cannot follow sanitization of equipment. Purge only with the end use product until there is no after taste in the product. *This is an NSF requirement.*

Extended lengths of product lines may require that an additional volume of sanitizing solution be prepared.

- C. Other:
- (1) Clean cloth towels.
 - (2) Bucket.
 - (3) Small brush (PN 22-0017) - included with installation kit.
 - (4) Extra nozzle.
 - (5) Sanitary gloves.

2.3 DAILY CLEANING

- A. Using a mild detergent solution, clean Top Cover and all exterior stainless steel surfaces. Clean exterior of dispensing valves and ice chute. Remove Cup Rest, clean Drip Tray and Cup Rest, and replace Cup Rest. Wipe clean all splash areas using a damp cloth soaked in cleaning solution. Clean beverage valves as specified by the valve manufacturer.

2.4 ICE BIN CLEANING - START UP AND MONTHLY

- A. Disconnect Dispenser from power source.
- B. Remove Top Cover.
- C. Remove Agitator Pin from Agitator Shaft. Slide Agitator Shaft rearward out of Motor Shaft and pull out of rear Bearing to remove.
- D. Remove Dispensing Wheel from Motor Shaft by sliding rearward.
- E. Remove Dispensing Wheel Shroud.
- F. Remove Splash Plate Assembly by lifting it up and out from the dispenser face.
- G. Using cleaning solution, described in Section 2.2, and a clean cloth or soft brush, clean all removable parts, sides of Ice Bin, Ice Chute, and surface of aluminum casting.
- H. Repeat Step G for all exterior surfaces of the dispenser.
- I. Using hot water, thoroughly rinse away the cleaning solution.
- J. Wearing sanitary gloves, soak a clean cloth towel in sanitizing solution, described in Section 2.2, and wash all surfaces of removable parts, sides of Ice Bin, Ice Chute, and surface of aluminum casting.
- K. Repeat Step J for all metal and plastic surfaces (*but not labels*) of the dispenser exterior.
- L. Wearing sanitary gloves, reassemble all removable parts.
- M. Fill Unit with ice and replace Top Cover.

NOTE

Lancer does not recommend the use of shaved, flake, nugget, or pellet ice in dispensers not properly equipped to do so.

- N. Reconnect Dispenser to power source.

2.5 CLEANING AND SANITIZING BEVERAGE COMPONENTS - FIGAL SYSTEMS

NOTE

Extended lengths of product lines may require more time for flushing and rinsing lines than stated below.

- A. Disconnect syrup lines from syrup containers (for example, quick disconnects, figal containers, etc.).
- B. Connect hose half of syrup line to a syrup tank filled with clean, potable, room temperature water. Connect CO₂ supply hose to tank and pressurize.
- C. Activate valve until water is dispensed. Flush and rinse line and fittings for a minimum of 60 seconds to remove all traces of residual product.

WARNING

TO AVOID POSSIBLE PERSONAL INJURY OR PROPERTY DAMAGE, DO NOT ATTEMPT TO REMOVE SYRUP TANK COVER UNTIL CO₂ PRESSURE HAS BEEN RELEASED FROM TANK.

- D. Disconnect CO₂ supply hose from the water filled syrup tank.
- E. Following the instructions as described in Section 2.2 above, mix appropriate amount of cleaning solution. Fill a tank with this solution. Connect hose half of syrup line to the tank. Connect CO₂ supply hose to tank and pressurize.
- F. Activate valve and draw cleaning solution through lines for a minimum of 60 seconds. This will ensure line is flushed and filled with cleaning solution. Allow line to stand for at least 30 minutes.
- G. Disconnect CO₂ supply hose from the tank.
- H. Connect hose half of syrup line to a tank filled with clean, potable, water at a temperature of 90° to 110°F. Connect CO₂ supply hose to tank and pressurize.
- I. Activate valve to flush and rinse line and fittings for a minimum of 60 seconds to remove all traces of cleaning solution. Continue rinsing until testing with phenolphthalein shows that the

- rinse water is free of residual detergent.
- J. Disconnect CO₂ supply hose from the tank.
- K. Following the instructions as described in 2.2 above, mix appropriate amount of sanitizing solution. Fill a tank with this solution. Connect hose half of syrup line to the tank. Connect CO₂ supply hose to tank and pressurize.
- L. Activate valve and draw sanitizing solution through line for a minimum of 60 seconds. This will ensure line is flushed and filled with sanitizing solution. Allow line to stand for at least 30 minutes.
- M. Disconnect CO₂ supply hose from the tank.
- N. Reconnect syrup lines to syrup containers (for example, quick disconnects, figal containers, etc.) and ready unit for operation.
- O. Draw drinks to refill lines and flush the sanitizing solution from the dispenser.

NOTE

Please note that a fresh water rinse cannot follow sanitization of equipment. Purge only with the end use product until there is no after taste in the product.

- P. Test dispenser in normal manner for proper operation. Taste dispensed product to ensure there is no off-taste. If off-taste is found, additional flushing of syrup system may be required.
- Q. Repeat cleaning, rinsing, and sanitizing procedures for each valve and each circuit.

2.6 CLEANING AND SANITIZING BEVERAGE COMPONENTS - BAG-IN-BOX SYSTEMS

NOTE

Extended lengths of product lines may require more time for flushing and rinsing lines than stated below.

- A. Disconnect syrup quick disconnect coupling from syrup packages and connect coupling to a bag valve removed from an empty Bag-in-Box (BIB) package.
- B. Place syrup inlet line in a clean container filled with clean, potable, room temperature water.
- C. Activate valve until water is dispensed. Flush and rinse line and fittings for a minimum of 60 seconds to remove all traces of residual product.
- D. Following the instructions as described in 2.2 above, mix appropriate amount of cleaning solution in a clean container. Place syrup inlet line in container filled with cleaning solution.
- E. Activate valve and draw cleaning solution through lines for a minimum of 60 seconds. This will ensure line is flushed and filled with cleaning solution. Allow line to stand for at least 30 minutes.
- F. Place syrup inlet line in a clean container filled with clean, potable, water at a temperature of 90° to 110°F.
- G. Activate valve to flush and rinse line and fittings for a minimum of 60 seconds to remove all traces of cleaning solution. Continue rinsing until testing with phenolphthalein shows that the rinse water is free of residual detergent.
- H. Following the instructions as described in 2.2 above, mix appropriate amount of sanitizing solution in a clean container. Place syrup inlet line in container filled with sanitizing solution.
- I. Activate valve and draw sanitizing solution through line for a minimum of 60 seconds. This will ensure line is flushed and filled with sanitizing solution. Allow line to stand for at least 30 minutes.
- J. Remove bag valve from quick disconnect coupling and reconnect syrup inlet line to syrup package. Ready unit for operation.
- K. Draw drinks to refill lines and to flush the chlorine sanitizing solution from the dispenser.

NOTE

Please note that a fresh water rinse cannot follow sanitization of equipment. Purge only with the end use product until there is no after taste in the product. This is an NSF requirement.

- L. Test dispenser in normal manner for proper operation. Taste dispensed product to ensure there is no off-taste. If off-taste is found, additional flushing of syrup system may be required.
- M. Repeat cleaning, rinsing, and sanitizing procedures for each valve and each circuit.

3. TROUBLESHOOTING

TROUBLE	CAUSE	REMEDY
3.1 Push Chute and nothing happens.	A. Dispenser not connected to power source. B. Microswitch defective. C. Wiring Harness not plugged in. D. PC Board defective.	A. Connect Dispenser to power source.* B. Replace Microswitch.* C. Plug in Wiring Harness.* D. Replace PC Board.*
3.2 Push Chute, Trap Door opens but Motor does not run.	A. Wiring Harness not plugged in. B. PC Board defective. C. Motor defective.	A. Plug in Wiring Harness.* B. Replace PC Board.* C. Replace Motor.*
3.3 Push Chute, Motor runs but Trap Door does not open.	A. Solenoid not connected to PC Board. B. Solenoid defective. C. PC Board defective.	A. Connect Solenoid to PC board.* B. Replace Solenoid.* C. Replace PC Board.*
3.4 Push Chute, Trap Door opens, Motor runs, but no ice dispenses.	A. Dispenser is out of ice. B. Agitator Pin is missing or damaged.	A. Fill unit with ice. B. Replace Agitator Pin.
3.5 Valves do not operate.	A. Keyswitch is off. B. Transformer tripped. C. Unit not plugged in.	A. Turn Keyswitch on. B. Reset Transformer. C. Plug in Dispenser.*
3.6 Water in Ice Bin.	A. Coldplate Drain is obstructed. B. Drain Hose is kinked.	A. Remove Drain Hose and 90 degree. fitting to obtain access to Drain. B. Replace Drain Hose.

* Light Emitting Diodes (LEDs) are provided on the PC Board to aid in troubleshooting electrical difficulties. Referring to the wiring diagram included in this manual (also affixed to the electrical box cover), the following information in Section 4 can be obtained from the LEDs.

4. LIGHT EMITTING DIODES (LEDS)

4.1 LED D3

This light is on when the ice dispense switch is activated. If the chute is depressed and the light does not turn on, check to see if the wire harness is connected or if the dispense switch is defective.

4.2 LED D4

This light is used on units with lid interlock switches. On the 4500 series ice-beverage dispenser, this light should always be lit. If it is not, check the Lid Interlock Jumper (black wire with 4 pin white connector).

4.3 LED D5

This light is on when +5VDC is present at the circuit board. It should be lit whenever the unit is connected to a power source. If the light is off, check to see if the internal circuit breaker on the transformer has tripped. If it has tripped, it can be reset by depressing the switch on the top of the transformer.

4.4 LED D6

This light is on when +32VDC is present at the circuit board. It should be lit whenever the unit is connected to a power source. If the light is off, check to see if the internal circuit breaker on the transformer has tripped. If it has tripped, it can be reset by depressing the switch on the top of the transformer.

4.5 LED D7

This light flashes when there is no ice between the sensors in the ice bin. If the bin is empty and the light is not flashing, check all wiring harnesses.

4.6 LED D8

This light is on when the solenoid is activated. When the chute is depressed, this light should turn on. If it does not, check to see if the solenoid leads are connected to the PC board or damaged, check continuity of solenoid. Replace if defective.

4.7 LED D9

This light is on when the motor is activated. When the chute is depressed, this light should turn on. If it does not, check to see if the motor harness is connected to the PC board or damaged, check continuity of motor harness and motor. Replace if defective.

5. AUTOMATIC AGITATION AND LOW ICE ALARM CONTROL

WARNING

THIS UNIT IS EQUIPPED WITH AUTOMATIC AGITATION. IT MAY ACTIVATE UNEXPECTEDLY. DO NOT PLACE HANDS, OR FOREIGN OBJECTS IN THE ICE STORAGE COMPARTMENT.

WHEN UNIT IS BEING SERVICED, CLEANED, OR SANITIZED, UNPLUG DISPENSER FROM THE POWER SOURCE.

Each Series 4500 ice beverage dispenser is equipped with automatic agitation for the ice bin. The unit is shipped with timing set at two (2) seconds ON every 60 minutes. Referring to the tables on the wiring diagram included in this manual (also affixed to the electrical box cover), the automatic agitation timing can be changed as follows. A set of DIP switches is provided to control the timing and low ice control.

5.1 DIP#1

This switch controls the low ice indicator light. With the switch in the ON position, the light operates when a low ice condition exists. In the OFF position, the light is turned off. The unit is shipped with the light switch in the ON position.

5.2 DIP#2

This switch controls the low ice audible alarm. With the switch in the ON position, the alarm operates when a low ice condition exists. In the OFF position, the alarm is turned off. The unit is shipped with the alarm switch in the OFF position.

5.3 DIP#3 & #4

These switches control the ON time for automatic agitation. By referring to the table and setting the switches as shown, ON times from one (1) second to four (4) seconds [in one (1) second increments] can be obtained. EXAMPLE: For three (3) second ON time, switch 3 should be in the ON position, and switch 4 should be in the OFF position. The unit is shipped with two (2) seconds ON time.

5.4 DIP#5 through #8

A. These switches control the OFF time for automatic agitation. By referring to the table and setting the switches as shown, OFF times from 10 minutes to 150 minutes (in 10 minute increments) can be obtained. EXAMPLE: For 40 minute OFF time, switch 5 should be in the OFF position, switch 6 should be in the ON position, switch 7 should be in the OFF position, and switch 8 should be in the OFF position. The unit is shipped with 60 minute OFF time.

B. To turn the agitation completely off, set switches 5 through 8 all OFF.

NOTES

6. ILLUSTRATIONS, PARTS LISTINGS AND WIRING DIAGRAMS, IBD25

6.1 DECALS AND LABELS, IBD25

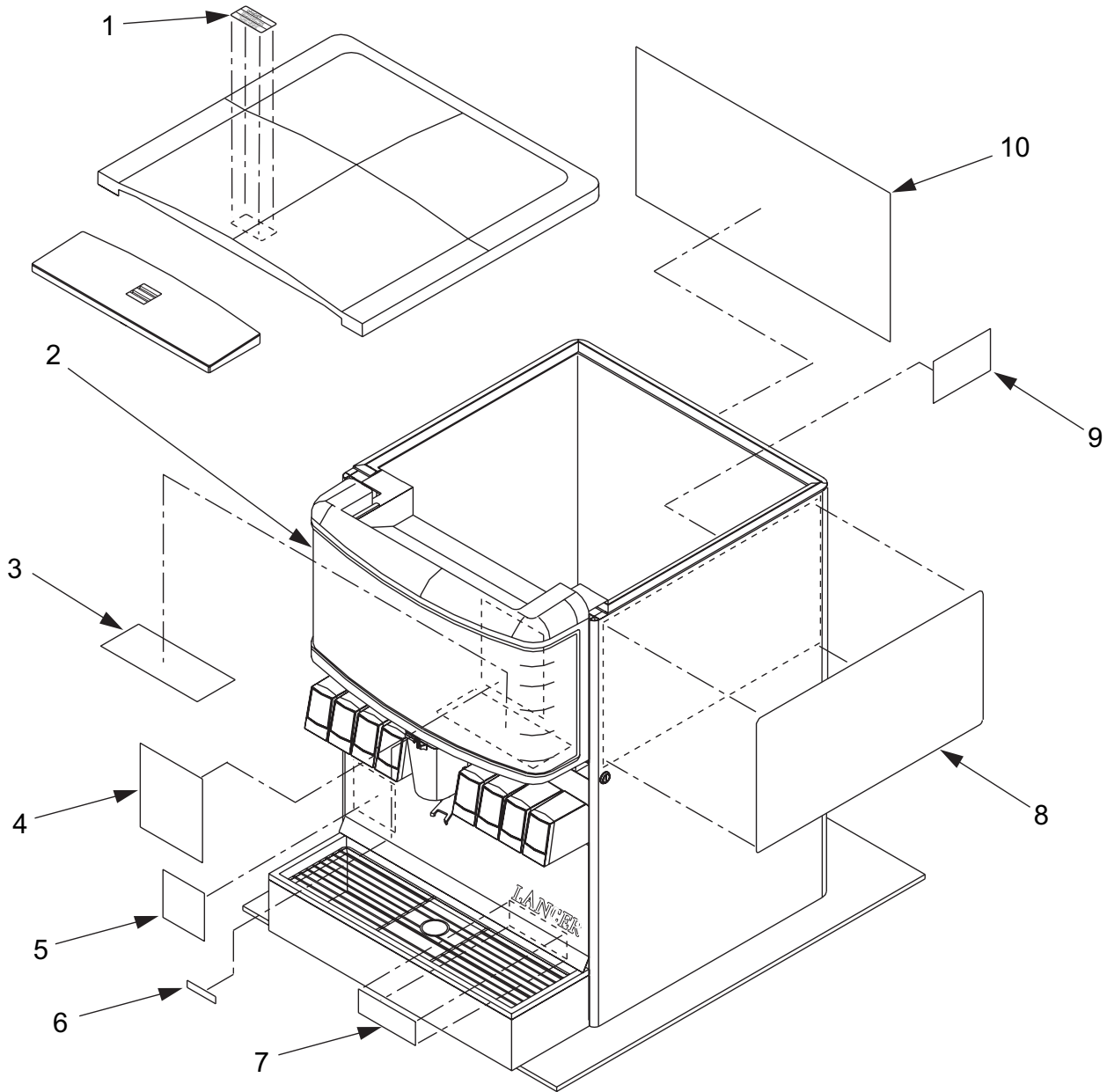

6.1 DECALS AND LABELS, IBD25 (CONTINUED)

<u>Item</u>	<u>Part No.</u>	<u>Description</u>	<u>Item</u>	<u>Part No.</u>	<u>Description</u>
-	85-4528H-100	IBD25H, Series 4500, 115V/60Hz, 8 LEV ®	R 5	06-2226	Label, Plumbing Diagram, IBD25 (See Section 6.2)
-	85-4538H-100	IBD25H, Series 4500, 230V,/50-60Hz, 8 LEV ®	6	06-1522	Label, Low Ice, IBD
1	06-1139	Label, Warning, Lid, IBD	7	06-1207	Label, Cold Plate Cleaning, IBD
2	06-2117/01	Panel, Graphic, IBD25, Round	8	06-2058/01	Decal, Wrapper, Side, IBD, Round
3	06-1184/01	Label, Cleaning, Merchandiser	9	06-1183	Label, Cleaning, Hopper, IBD
R 4	06-1182/04	Label, Wiring Diagram, 115V, IBD (See Section 6.6)	10	06-2118/01	Decal, Wrapper, Back, IBD25, Round
R -	06-1521/02	Label, Wiring Diagram, 230V, IBD (See Section 6.7)	-	12-0193	Ice Out Indicator
			-	27-0068,	Lens, Clear, Marquee
			-	27-0071,	Diffuser, Marquee

R in margin indicates change or revision

6.2 Plumbing Diagram

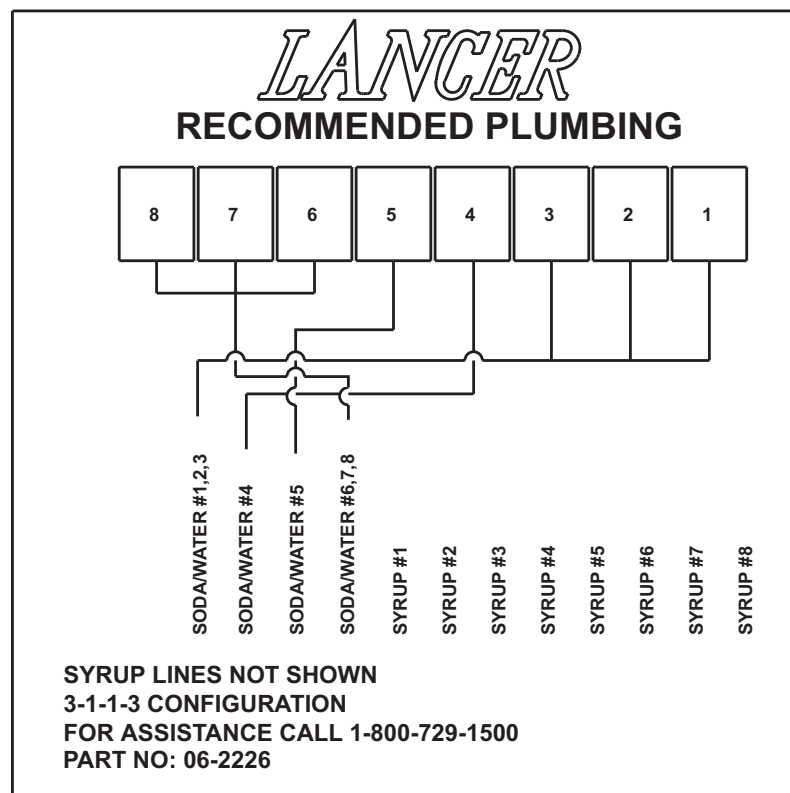

6.3 FINAL ASSEMBLY, POST-MIX IBD AND ICE DISPENSER, IBD25

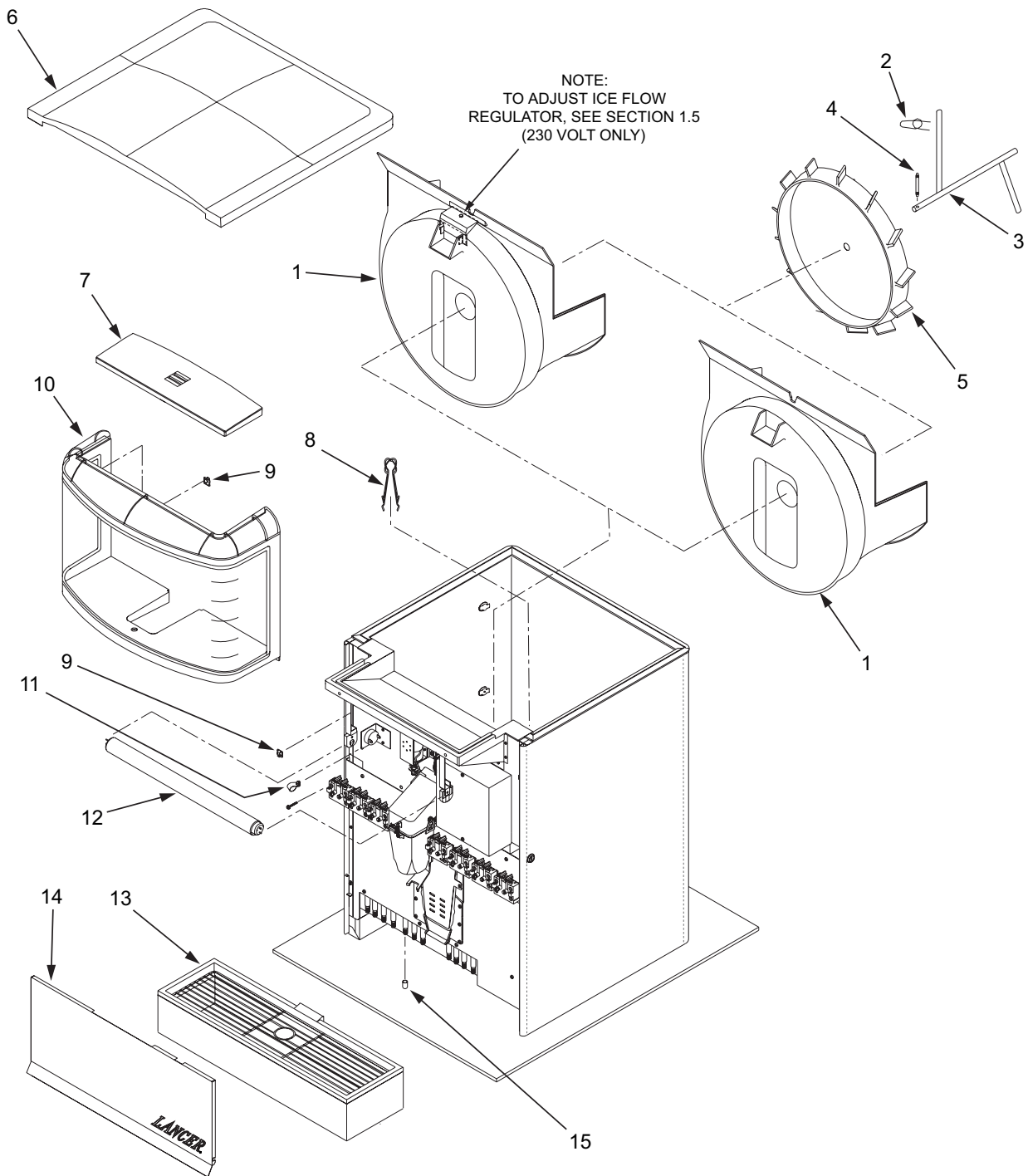

6.3 FINAL ASSEMBLY, POST-MIX IBD AND ICE DISPENSER, IBD25 (CONTINUED)

<u>Item</u>	<u>Part No.</u>	<u>Description</u>
-	85-4528H	IBD25H, Series 4500, 115V/60Hz, 8 Valve
-	85-4538H	IBD25H, Series 4500, 230V/50-60Hz, 8 Valve
R 1	05-1658/01	Wheel Shroud Assy, IBD25, Mod (115V)
R -	82-2705	Wheel Shroud Assy, IBD25, Mod (230V Only)
R 2	03-0368	Retainer, RUE-14-S
R 3	23-1373	Agitator Assy, HEX, IBD (115V)
R -	23-1355	Agitator Assy, IBD, (230V Only)
R 4	10-0762	Pin, Agitator, IBD, Single Retainer
R 5	82-3556	Dispensing Wheel Assy, HEX, IBD (115V)
R -	82-3413	Dispensing Wheel Assy, IBD (230V Only)
6	05-1659	Lid, Back, IBD25, Round
7	05-1476	Lid, Front, IBD, Round
8	23-1038/01	Drain, Spider, IBD
9	03-0300	Wire Clip, Adhesive
10	82-2706	Merchandiser Assy, IBD25
11	03-0049	Clip, Cord
12	12-0146/01	Lamp, 18 Inch, 15W, T8
13	82-2707-SP	Drip Tray Assy, IBD, 25 Inch Wide (Before December 30, 2003)
--	82-3186-SP	Drip Tray Assy, IBD, 25 Inch Wide (After December 30, 2003)
14	30-7517/01	Plate, Splash, IBD, 25 Inch Wide (Before December 30, 2003)
--	30-8625	Plate, Splash, IBD, 25 Inch Wide (After December 30, 2003)
15	04-0559	Cap, Protective, Vinyl, VC-375-8

R in margin indicates change or revision

6.4 FAUCET PLATE AND ICE CHUTE SUB-ASSEMBLY, POST-MIX, IBD25

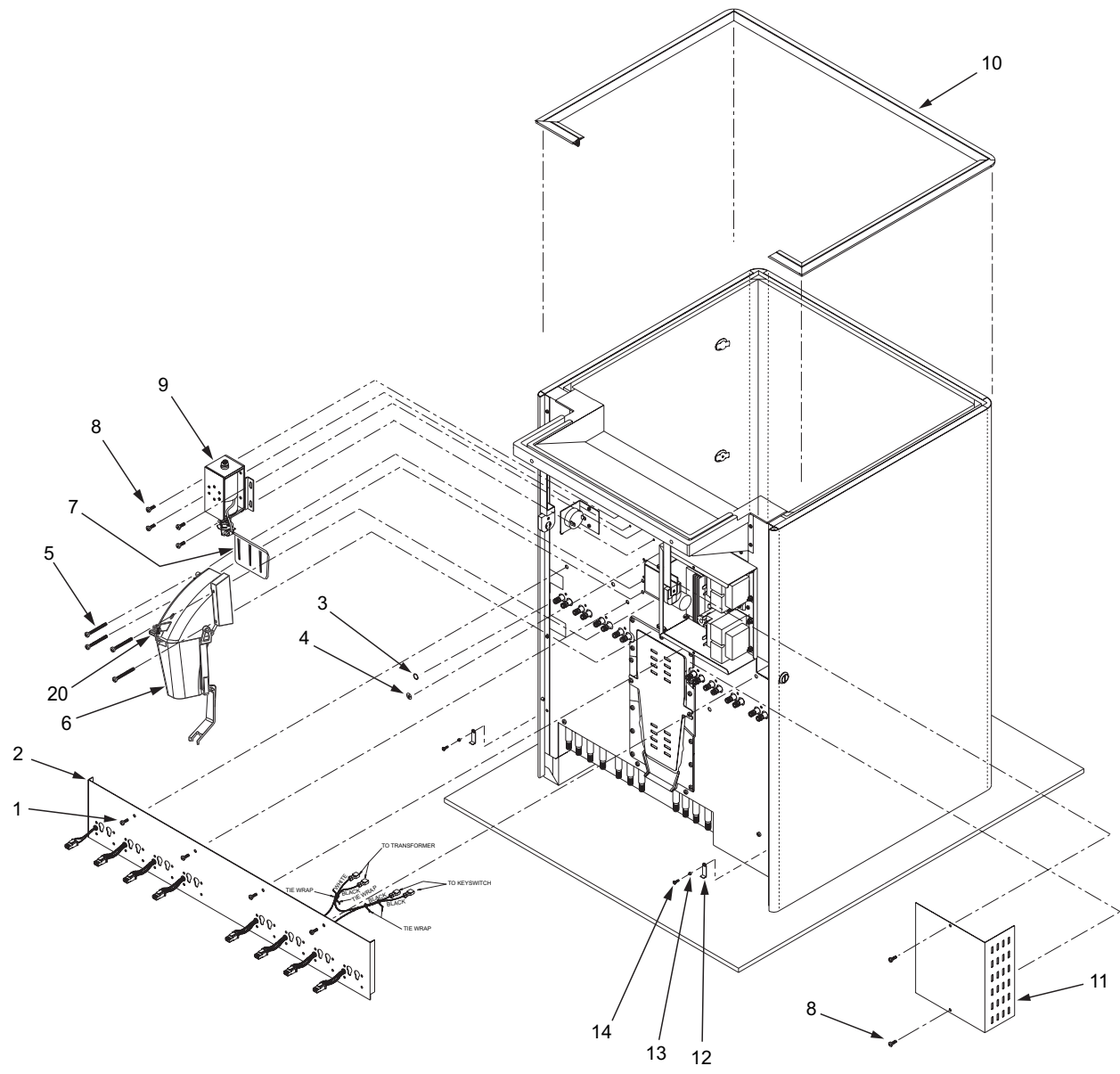

6.4 FAUCET PLATE AND ICE CHUTE SUB-ASSEMBLY, POST-MIX, IBD25 (CONTINUED)

<u>Item</u>	<u>Part No.</u>	<u>Description</u>	<u>Item</u>	<u>Part No.</u>	<u>Description</u>
-	85-4528H	IBD25H, Series 4500, 115V/60Hz, 8 Valve	R 10	82-2704	Trim Assy, IBD25, Round
-	85-4538H	IBD25H, Series 4500, 230V/50-60Hz, 8 Valve	11	30-5876/01	Cover, Electrical Box, IBD
1	04-0308	Screw, 10 - 32 X 0.438	R 12	30-6145	Lock, Drip Tray, IBD
2	82-2703	Faucet Plate Assy, IBD25	R 13	10-0364	Spacer, Drip Tray Lock, IBD
R 3	02-0005	O-Ring, 2-010	R 14	04-0529	Screw, 8 - 32 x 0.750, PH
R 4	06-0877	Label, Ground	R 15	10-0732	Shaft, ice Chute Door
R 5	04-0553	Screw, 10 - 24 X 1.75, LG	R 16	05-0359	Bushing, Shaft
R 6	82-3538	Chute Assy, Printed, Small Dispenser, IBD	R 17	03-0113	Ring, Retaining (5144-12)
R 7	05-0928/01	Trap Door, IBD	R 18	05-0546	Lever, Door
R 8	04-0504	Screw, 8 - 18 x 0.375, PHD	R 19	03-0205	Ring, Retaining (5304-25)
R 9	82-1566/01	Solenoid Assy	R 20	12-0244	Ice Door Switch
R A	03-0086	Ring, Retaining (5304-18)			
R B	04-0328	Washer, Rubber			
R C	04-0327	Washer, Flat			
R D	12-0195	Solenoid, D-90			
R E	30-5165	Bracket, Solenoid			
R F	23-1380	Plunger Assy			
R G	10-0496	Pin, Solenoid Assy			
R H	03-0110	Spring, Solenoid			
R I	03-0111	Ring, Retaining (5133-62)			
R J	10-0353	Linkage, Door, IBD			
R K	04-0320	Screw, 8 - 32 x. 0.187, PHD			

R in margin indicates change or revision

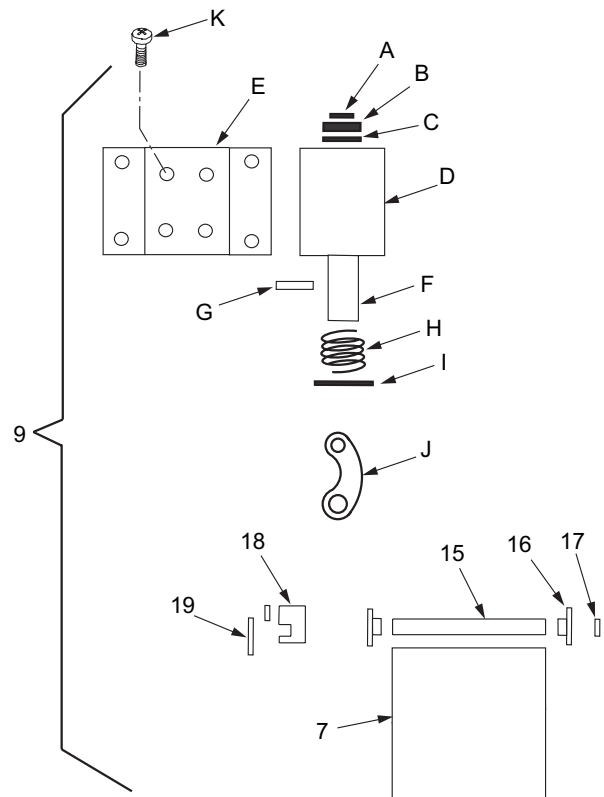

6.5 ELECTRICAL BOX AND GEAR MOTOR SUB-ASSEMBLY, POST-MIX, IBD25

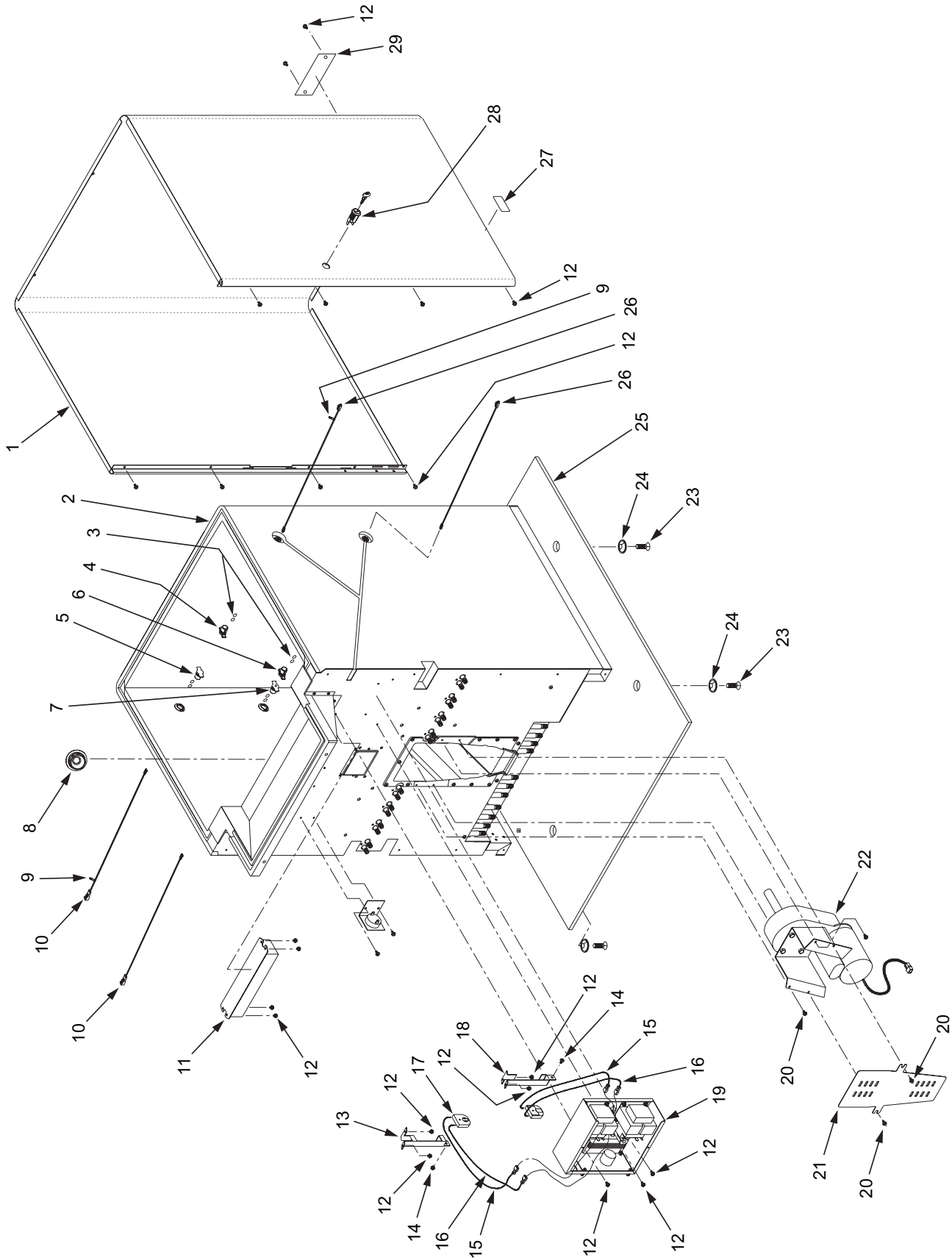

6.5 ELECTRICAL BOX AND GEAR MOTOR SUB-ASSEMBLY, POST-MIX, IBD25 (CONTINUED)

Item	Part No.	Description
-	85-4528H	IBD25H, Series 4500, 115V/60Hz, 8 Valve
-	85-4538H	IBD25H, Series 4500, 230V/50-60Hz, 8 Valve
1	30-7153	Wrapper Assy, IBD25, Round (Before December 30, 2003)
--	30-8628	Wrapper Assy, IBD25, Round (After December 30, 2003)
2	82-2701H	Tank Assy, Foamed, IBD25
R 3	02-0155	O-Ring, 2-015
4	05-1858	Body, Emitter, Sensor, Plug
5	05-1859	Body, Detector, Sensor, Plug
6	52-2352	Emitter Assy, Sensor
7	52-2353	Detector Assy, Sensor
8	02-0406	Seal, Shaft, Motor, IBD
9	06-2488	Label, Ice Link Tag, IBD
10	52-2450	Harness Assy, Detector, IBD
11	52-2122	Ballast Assy, Long Lead, 230V, IBD
12	04-0504	Screw, 8 - 18 x 0.375
13	30-6153	Bracket, Left, Light, IBD
14	04-0237	Screw, 8 - 32 x 0.250
15	52-1584	Harness Assy, Light, Black
16	52-1583	Harness Assy, Light, White
17	11-0295	Socket, 660W/600V MAX
18	30-6152	Bracket, Right, Light, IBD
R 19*	82-1529/02	Electrical Box Assy, IBD, 115V*
R -**	82-2017/02	Electrical Box Assy, IBD, 230V**
R -	52-1527	Power Cord Assy, 115V
R -	52-2006	Power Cord Assy, 230V
20	04-0069	Screw, 10 - 16 X 0.500
21	30-6147	Cover, Motor, IBD
R 22	82-3688	Drive Assy, Motor, HEX, IBD, 115V
-	82-2018	Drive Assy, Motor, IBD, 230V
23	04-0203	Screw, 3/8 - 16 X 1.00, FHD
24	07-0211	Washer, Shipping Base
25	90-0985	Shipping Board, IBD, 25 Inch Wide
26	52-2449	Harness Assy, Emitter, IBD
27	06-1580	Label, Patent
R 28***	12-0097	Switch, Key Lock***
29	30-7113	Cover, Cutout, Wrapper, IBD
R -	05-1555	Rear Bearing (Not Shown)

R REF Ballast Assy Components (Not Shown)

R --	12-0104	Starter, 115VAC, 14-20 WA
R --	12-0194	Starter, Base

R REF Electrical Box Assy Components (Not Shown)

R *--	52-1436/05	PCB Assy, Available as Spare Part
R *--	25-0039	120V-24V Transformer, Available as Spare Part
R *--	25-0047	75VA-24V Transformer, Available as Spare Part
R **--	25-0040	220V-24V Transformer, Available as Spare Part
R ***--	81-0126	Key, Available as Spare Part

R in margin indicates new or revised data

6.6 WIRING DIAGRAM - 115V/60HZ, SERIES 4500 IBD

WIRING DIAGRAM FOR LANCER ICE DISPENSER WITH LOW ICE SENSING (TYP)

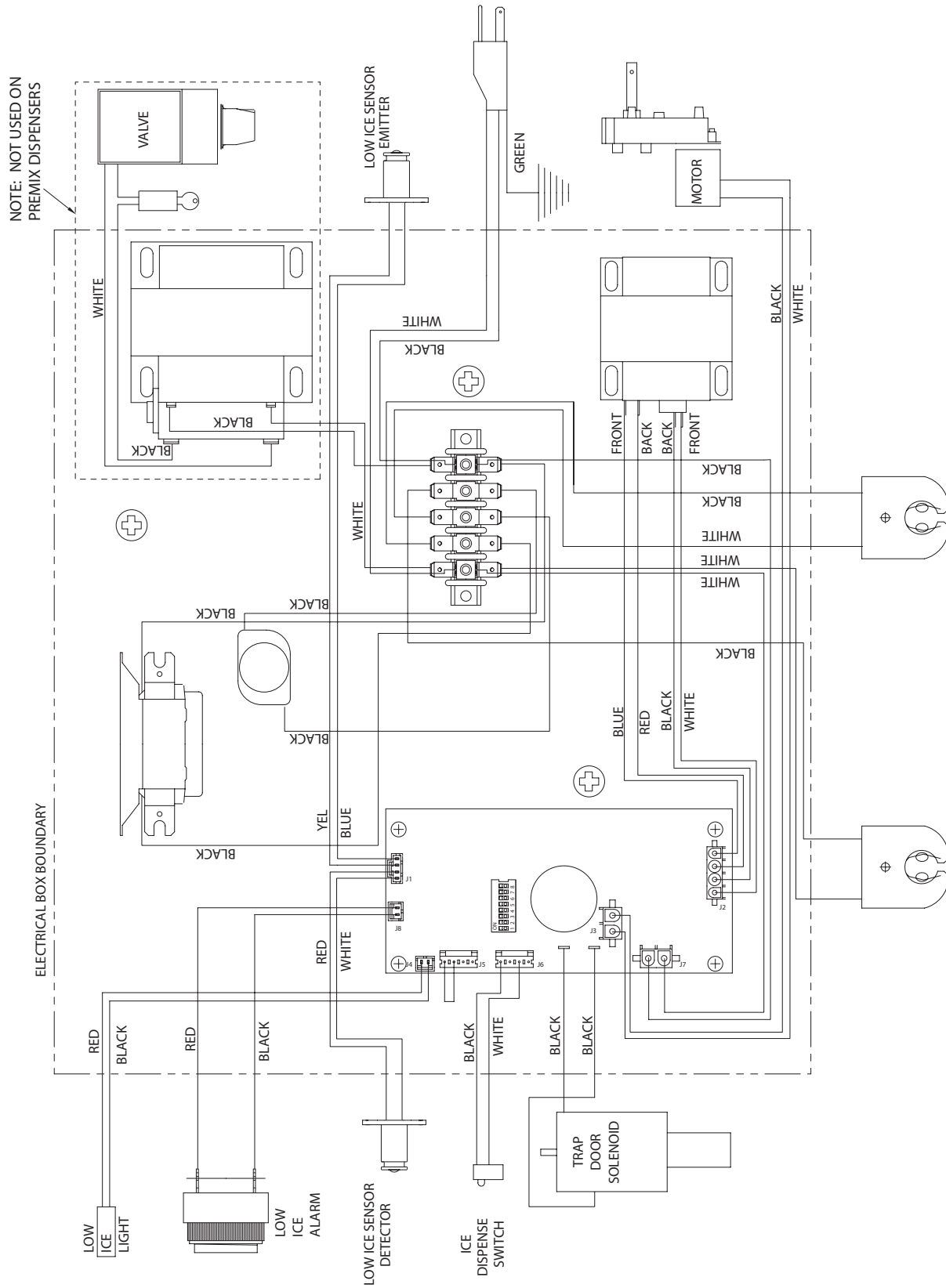

6.7 WIRING DIAGRAM - 230V/50-60HZ, SERIES 4500 IBD

WIRING DIAGRAM FOR LANCER ICE DISPENSER WITH LOW ICE SENSING (TYP.)

