



NPB-70

Service Manual
Portable Bedside Capnograph



Portable Handheld Capnograph

Service Manual

Notice: Purchase of this instrument confers no express or implied license under any Oridion Medical patent or Nellcor Puritan Bennett patent to use the instrument with any accessory that is not manufactured or licensed by Oridion Medical 1987 Ltd.

The following are registered trademarks of Oridion Medical 1987 Ltd.: Microstream and FilterLine.

Capnography covered by one or more of the following U.S. patents and foreign equivalents: 4,755,675; 5,063,275; 5,300,859; 5,657,750.

TABLE OF CONTENTS

List of Figures
List of Tables

Section 1: Introduction	1-1
1.1 Manual Overview	1-1
1.2 Warnings, Cautions, and Notes	1-1
1.2.1 Warning.....	1-1
1.2.2 Caution.....	1-1
1.2.3 Note.....	1-1
1.3 Product Description	1-2
Section 2: Required Equipment	2-1
2.1 Required Equipment	2-1
Section 3: Cleaning	3-1
3.1 Cleaning	3-1
3.1.1 Procedure.....	3-1
Section 4: Service Mode	4-1
4.1 Introduction	4-1
4.2 Service Level 1	4-1
4.2.1 Information Screen.....	4-1
4.2.2 Event Messages Screen	4-1
4.2.3 Interface Test Screen.....	4-2
4.2.4 Accessing Service Mode and Service Level 1 ...	4-3
4.3 Service Level 2	4-5
4.3.1 Default Alarm Limits.....	4-7
4.3.2 Default Settings.....	4-8
4.3.3 Flow Calibration	4-9
Section 5: Troubleshooting	5-1
5.1 Introduction	5-1
5.2 Who Should Perform Repairs	5-1
5.3 Repair Level Supported	5-1
5.4 How to Use This Section	5-1
5.5 Obtaining Replacement Parts.....	5-1
5.6 Troubleshooting Guide	5-2
Section 6: Flow Calibration Check	6-1
6.1 Introduction	6-1
6.2 Flow Rate Check	6-1
6.3 Flow Calibration Process	6-2
Section 7: Disassembly Guide	7-1
7.1 Introduction	7-1
7.2 Opening the Handheld Capnograph Case.....	7-2
7.3 Replacing the CO ₂ Board	7-4
7.4 Replacing the Pump Assembly	7-5
7.5 Replacing the Flow System	7-6
7.5.1 Replacing the lines to the pump.....	7-7
7.5.2 Replacing the lines to the solenoid	7-8
7.6 Replacing LCD and 7-Segment Display	7-10
7.6.1 Replacing the LCD.....	7-10
7.6.2 Replacing the 7-Segment Display.....	7-10

7.7	Replacing Housing Components	7-11
7.7.1	ON/OFF Button and Gas outlet.....	7-11
7.7.2	Keypads	7-11
7.7.3	Front Cover	7-11
7.7.4	Rear Cover.....	7-11
7.8	Updating Software Version	7-12
Section 8: Electrical Safety Tests.....		8-1
8.1	Electrical Safety Tests	8-1
Section 9: Periodic Maintenance.....		9-1
9.1	Periodic Maintenance	9-1
Section 10: Performance Verification		10-1
10.1	Flow System Leak Check	10-1
10.1.1	Flow System Leak Check Procedure.....	10-1
10.2	Performance Verification Procedure.....	10-2
Section 11: Packing For Shipment.....		11-1
11.1	General Instructions.....	11-1
11.2	Packing Handheld Capnograph in Original Carton.....	11-1
11.3	Packing in a Different Carton.....	11-1
Section 12: Specifications.....		12-1
12.1	Physical	12-1
12.1.1	Size	12-1
12.1.2	Weight.....	12-1
12.1.3	Noise Emission	12-1
12.2	Environmental.....	12-1
12.2.1	Temperature.....	12-1
12.2.2	Relative Humidity	12-1
12.2.3	Pressure and Altitude.....	12-1
12.3	Safety Standards	12-1
12.4	Performance	12-2
12.5	Power Specifications	12-3
12.5.1	External Power Source	12-3
12.5.2	Internal Power Source.....	12-3
12.6	Components and User interface	12-3
12.6.1	Displays.....	12-3
12.6.2	Controls and Indicators	12-3
12.6.3	Connections	12-3
Section 13: Spare Parts.....		13-1
13.1	Spare Parts List	13-1
Glossary of Terms		

LIST OF FIGURES

1-1	Handheld Capnograph.....	1-2
1-2	LCD Screen and 7-Segment Digital Display.....	1-2
7-1	Removing the Battery Pack	7-2
7-2	Removing Mounting Screws	7-3
7-3	Separating Rear and Front Covers.....	7-3
7-4	Replacing CO ₂ Board and Housing Components.....	7-4
7-5	Replacing the Pump	7-5
7-6	Flow System	7-6
7-7	Main Line	7-7
7-8	Exhaust Line	7-7
7-9	Lines to Solenoid (Zeo line, Input line 1, Input line 2	7-8
7-10	Zero line.....	7-9
7-11	Replacing LCD and 7-Segment Display	7-10
7-12	Replacing EPROM.....	7-12
10-1	Leak Test Jig Connection	10-1
10-2	Initialization Screen.....	10-2
10-3	Measuring Mode	10-2
10-4	Quick Guide	10-3
10-5	Connecting the monitor to Printer/PC with Communication Adapter Kit	10-9
11-1	Packing the NPB-75 in Original Packing	11-2

LIST OF TABLES

4-1	Accessing Service Mode and Changing Parameter Settings.....	4-3
4-2	Accessing Service Level 2.....	4-5
4-3	Changing Default Alarm Limits	4-7
4-4	Changing Default Settings	4-8
4-5	Accessing Flow Calibration.....	4-9
5-1	Troubleshooting Guide	5-2
5-2	Advisory Message	5-4
5-3	Event Messages	5-5
6-1	Flow Calibration	6-2
10-1	CO ₂ Calibration Check.....	10-3
10-2	Calibration Process.....	10-6
10-3	Calibration Process -Troubleshooting.....	10-7
10-4	Accessing Handheld Capnograph Print Functions	10-10
13-1	Spare Parts List	13-1

SECTION 1: INTRODUCTION

- 1.1 Manual Overview
 - 1.2 Warnings, Cautions, and Notes
 - 1.3 Product Description
-

1.1 MANUAL OVERVIEW

This manual contains information for servicing the Handheld Capnograph (the monitor). Only authorized service personnel should service this product. The Handheld Capnograph Operator's Manual is an integral part of the service procedures. Before servicing the monitor, read the Operator's Manual carefully for a thorough understanding of how to operate the unit.

Only use the tools and test equipment as specified in this manual. Only use original spare parts available from your local distributor.

<p>Warning: Incorrect procedures may harm the patient, or damage the monitor.</p>
--

1.2 WARNINGS, CAUTIONS, AND NOTES

1.2.1 Warning

A warning precedes an action that may result in injury or death to the patient or user. Warnings are boxed and highlighted in boldface type.

1.2.2 Caution

A caution precedes an action that may result in damage to, or malfunction of, the monitor. Cautions are highlighted in boldface type.

1.2.3 Note

A note gives information that requires special attention.

1.3 PRODUCT DESCRIPTION

The device is a Handheld Capnograph that continuously monitors end tidal carbon dioxide (EtCO₂) and respiratory rate. The monitor is for attended monitoring only and must be used in the continuous presence of a qualified healthcare provider. It is intended for use in any environment where continuous, noninvasive monitoring of these parameters is desired, including hospital and mobile use (when protected from excessive moisture such as direct rainfall).

The monitor is intended for use on adult, pediatric, and infant/neonatal patients.



Figure 1-1: Handheld Capnograph

The monitor is operated using a four-key keypad. Measurements are displayed on the front panel on the 7-segment LED digital displays (LED) and on the Liquid Crystal graphic display (LCD) as shown in Figure 1-2. Refer to the Handheld Capnograph Operator’s Manual for complete operating instructions.

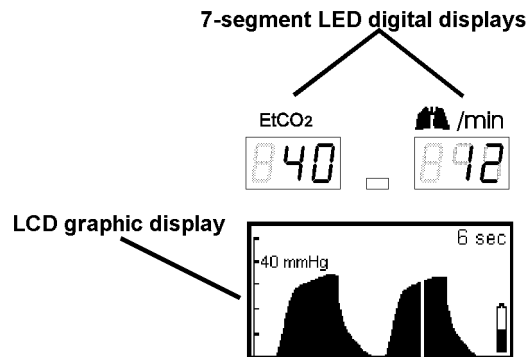

Figure 1-2: LCD Screen and 7-Segment Digital Display

SECTION 2: REQUIRED EQUIPMENT

2.1 Required Equipment

2.1 REQUIRED EQUIPMENT

You will need the following equipment to disassemble, replace parts, check, adjust, or calibrate the monitor.

Note: For ordering spare parts, contact your local distributor.

For Disassembly and Reassembly:

- Phillips-head screwdriver (medium)
- IC Extractor for PLCC socket
- Threadlocker glue e.g. Loctite® 222 super screw lock

For Calibration, Checks and Adjustments:

- Calibration Gas (5% CO₂ in air)
- FilterLine or FilterLine H and a connecting means
- Leak Test Jig
- Vacuum manometer with a range of 0-500 mBar
e.g. MPL-3200-DM, Digital Manometer MicroPneumatic Logic, Inc.
- Communication Adapter Kit (only necessary to verify print and PC functions)
- Seiko DPU-414 printer (only necessary to verify print functions)
- External power supply
- Handheld Capnograph Operator's Manual
- Flow Meter e.g. Top Track Mass Flow Meter,
model: 822-13-OV1-PV1-V1, Sierra Instruments, Inc.

Warning: Observe ESD (electrostatic discharge) precautions when handling, adjusting or performing any procedure with the monitor internal components.

SECTION 3: CLEANING

3.1 Cleaning

3.1 CLEANING

Always clean the outer surface of the monitor before servicing.

Warning: Always wear latex or surgical gloves when cleaning or servicing the Handheld Capnograph monitor after hospital use.

Warning: Do not allow liquids to drip inside the housing.

Warning: Do not clean internal components.

Warning: Do not use cleaning materials based on: phenols, halogen producing compounds, strong organic acids, or oxygen producing compounds.

3.1.1 Procedure

1. Unplug the unit from AC mains supply.
2. With a damp cloth, gently wipe the outer case of the monitor with a disinfectant based on aldehyde, alcohol or quaternary ammonium producing compounds.

SECTION 4: SERVICE MODE

- 4.1 Introduction
 - 4.2 Service Level 1
 - 4.3 Service Level 2
-

4.1 INTRODUCTION

The monitor supports a service mode built into the instrument's firmware. The architecture of the monitor's service mode divides the service mode into two levels as described in the sections below.

- Service Level 1
- Service Level 2

To access the service mode (levels 1 and 2), refer to Tables 4-1 and 4-2.

4.2 SERVICE LEVEL 1

The Service Level 1 provides information and tools on three service screens to test and calibrate specific functions without disassembling the monitor.

- Information Screen
- Event Messages Screen
- Interface Test Screen

From these display screens the service technician can check the operating hours counter and event messages, test the Human Interface functions (HMI), set the light detection threshold, adjust the LCD contrast middle point and do a calibration check and a calibration process, if necessary. Refer to Table 4-1.

4.2.1 Information Screen

The information screen displays the monitor's serial CO₂ board number, the number of operating hours, and the CO₂ board's software version.

4.2.2 Event Messages Screen

The monitor automatically performs a series of built-in tests (BITs) at start-up and during operation to check sub-systems and modules for errors. The event messages screen lists the last five event messages, the time each occurred relative to the unit's operating hours, and a recommended service action. There are two event messages and each has a specific response as follows:

Event Message:	Action:
CO ₂ board	Replace COboard
Flow	Replace Flow System and/or Pump Refer to Section 5: <i>Troubleshooting</i>

Note: To exit the service mode and save event messages, turn off the monitor. Event messages will be erased when exiting the service mode by a long press of .

4.2.3 Interface Test Screen

The interface test screen shows four parameters (listed below) that provide tools for the user to test, adjust, and calibrate the unit's interfacing systems.

- HMI Test
- Light Detector
- Contrast Cal. (Calibration)
- CO₂ Calib. (Calibration)

4.2.3.1 HMI Test

When the **HMI Test** is turned on, the monitor performs a self-test of the following sub-systems:

- Buzzer (sounds for one second)
- LCD graphic screen shows a checkerboard pattern
- 7-segment digital display (8s scroll left to right)
- Alarm bar (lights red, yellow, off)
- Backlight (turns on and off)
- Alarm silence indicator (light turns on and off)

When the HMI test is completed the status field returns automatically to "OFF".

4.2.3.2 Light Detector

The **Light Detector** parameter allows the service technician to set the threshold value of the phototransistor. The default value is 1 and the range is from 1 to 5 with 1 as the most sensitive (backlight on at all times) and 5 as the least sensitive (backlight off). The threshold value should be set according to the lighting conditions of the working environment. A higher threshold value saves on battery power consumption.

Note: When the monitor's power management is set to **Low**, the backlight is off.

4.2.3.3 Contrast Cal. (calibration)

The **Contrast Cal.** gives the service technician the option to change the middle point default value of the contrast intensity of the LCD.

Table 4-1 describes how to change the contrast cal. settings.

4.2.3.4 CO₂ Calib. (calibration)

The **CO₂ Calib.** allows the service technician to perform a calibration check and calibration process to ensure the accuracy of the monitor. Section 10: *Performance Verification* describes the calibration check and calibration process procedure.

4.2.4 Accessing Service Mode and Service Level 1.

Table 4-1 describes how to access the service mode, change parameter settings and how to change **Contrast Cal.** settings.

Table 4-1: Accessing Service Mode and Changing Parameter Settings















Objective	Action	Response
To access Service Mode	During self-test, press and hold simultaneously  and 	Self-test occurs and the Information Screen appears:   
To access Event Messages	long press 	
To access Interface Test Screen	long press 	
To change the parameter setting or value	short press 	

Table 4-1: Accessing Service Mode and Changing Parameter Settings (Continued)

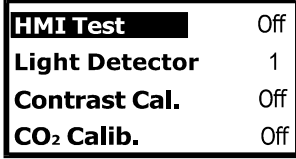
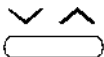
<p>To move to the next parameter (moving to the next parameter accepts and saves changed values)</p>	<p>short press</p> 	<table border="1"> <tr> <td>HMI Test</td> <td>On</td> </tr> <tr> <td>Light Detector</td> <td>1</td> </tr> <tr> <td>Contrast Cal.</td> <td>Off</td> </tr> <tr> <td>CO₂ Calib.</td> <td>Off</td> </tr> </table>	HMI Test	On	Light Detector	1	Contrast Cal.	Off	CO₂ Calib.	Off
HMI Test	On									
Light Detector	1									
Contrast Cal.	Off									
CO₂ Calib.	Off									
<p>To change Contrast Cal. setting to set</p>	<p>short press</p> 	<table border="1"> <tr> <td>HMI Test</td> <td>Off</td> </tr> <tr> <td>Light Detector</td> <td>1</td> </tr> <tr> <td>Contrast Cal.</td> <td>Set</td> </tr> <tr> <td>CO₂ Calib.</td> <td>Off</td> </tr> </table>	HMI Test	Off	Light Detector	1	Contrast Cal.	Set	CO₂ Calib.	Off
HMI Test	Off									
Light Detector	1									
Contrast Cal.	Set									
CO₂ Calib.	Off									
<p>To start Contrast Cal.</p>	<p>short press</p> 	<p>“Contrast Cal.” flashes.</p>								
<p>To Adjust Contrast Cal. middle point</p>	<p>press</p>  <p>until desired setting is reached. (Pressing on the left lightens the screen, and pressing on the right darkens the screen.)</p>	<p>Screen lightens or darkens</p>								
<p>To accept new setting</p>	<p>short press</p> 	<table border="1"> <tr> <td>HMI Test</td> <td>Off</td> </tr> <tr> <td>Light Detector</td> <td>1</td> </tr> <tr> <td>Contrast Cal.</td> <td>Off</td> </tr> <tr> <td>CO₂ Calib.</td> <td>Off</td> </tr> </table>	HMI Test	Off	Light Detector	1	Contrast Cal.	Off	CO₂ Calib.	Off
HMI Test	Off									
Light Detector	1									
Contrast Cal.	Off									
CO₂ Calib.	Off									
<p>To reset and return to measuring mode (automatically erasing the event messages memory)</p>	<p>long press</p> 	<table border="1"> <tr> <td>Reset. Please wait...</td> </tr> </table>	Reset. Please wait...							
Reset. Please wait...										
<p>To exit service mode from any service screen without erasing the event messages memory</p>	<p>Turn off the monitor</p>									

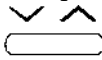
4.3 SERVICE LEVEL 2

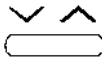
The Service Level 2 gives the service technician tools on three service screens:

- Default Alarm Limits
- Default Settings
- Flow Calibration

To access this service level, the service technician must enter a valid password (1627), refer to Table 4-2.

Note: The password should not be disclosed to avoid unauthorized setting of parameters.

Table 4-2: Accessing Service Level 2







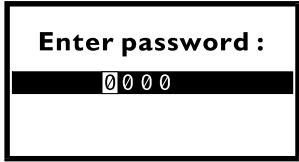
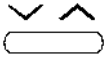
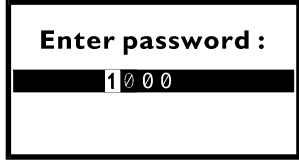

Objective	Action	Response
To access Service Level 2	After entering the service mode long press x3 	Password Screen appears 
Enter Password: 1627		
Enter the 1st digit	short press (right) x1  Pressing on the right arrow scrolls the numbers up, the left arrow scrolls the numbers down.	
Move to the next digit	short press 	
Enter the 2nd digit	short press (right) x6 	
Repeat the same procedure as above for the next two digits (2, 7).		

Table 4-2: Accessing Service Level 2 (Continued)

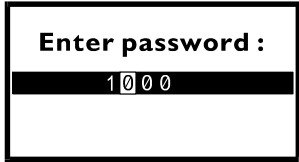
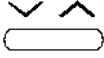
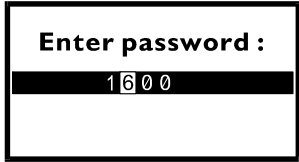
Objective	Action	Response
To access the Alarm Limits Menu after entering last password digit	short press 	
In case you entered a wrong digit		
To restart password validation process	long press 	
To reset and return to measuring mode (automatically erasing event messages)	long press 	
To exit service mode and save event messages	Turn off the monitor.	

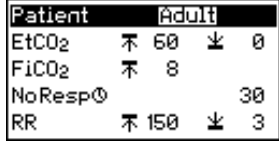
4.3.1 Default Alarm Limits

The service technician can change the default alarm limits for either patient mode (Adult or Neonatal).

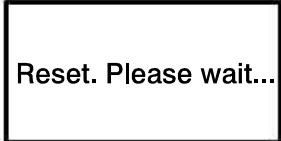



The monitor has the following alarms with adjustable level settings:

- EtCO₂ high and low levels (mmHg)
- FiCO₂ high level (mmHg)

Refer to Table 4-3 for changing the settings of the above mentioned parameters.

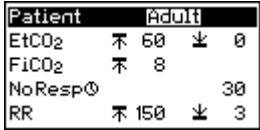
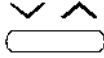
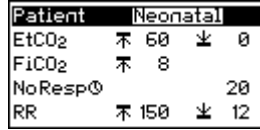
Warning: Changing default settings will permanently change the user's start up value and should be verified with the responsible clinical personnel.

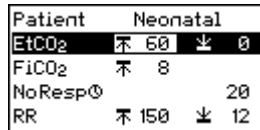
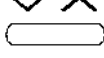
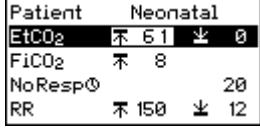
Table 4-3: Changing Default Alarm Limits

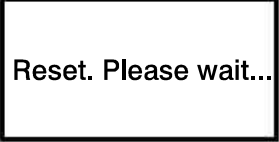
Objective	Action	Response
To access the Alarm Limits Menu after entering last password digit	short press 	
To change the patient mode	short press 	
To access a new parameter	short press 	
To change the value	short press 	
To reset and return to measuring mode	long press 	
To exit service mode and save event messages	Turn off the monitor.	

4.3.2 Default Settings







The service technician can change two default settings (refer to Table 4-4):

- 3 Min Alert
- BTPS (body temperature, pressure, saturation)

When the **3 min Alert** is **ON**, the unit will beep every three minutes to remind the user that an alarm (or all alarms) are set to **OFF**.

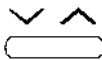
When BTPS is **ON**, the CO₂ value is corrected for this factor.

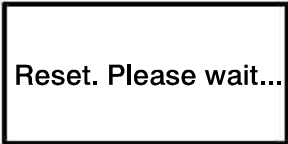
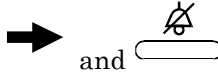
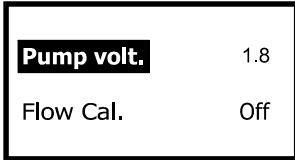
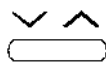
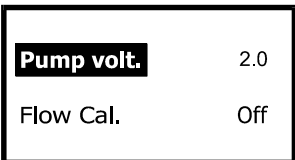

Table 4-4: Changing Default Settings

Objective	Action	Response
To access the <i>Default Settings Menu</i> (after accessing the <i>Alarm Limits Menu</i>)	long press 	
To change the setting	short press 	
To access BTPS parameter (and save the changed setting)	short press 	
To reset and return to measuring mode	long press 	
To exit service mode and save event messages	Turn off the monitor.	

4.3.3 Flow Calibration

The Flow Calibration screen allows the service technician to perform flow calibration after flow adjustment and/or pump or flow system replacement, refer to Table 4-5.

Table 4-5: Accessing Flow Calibration

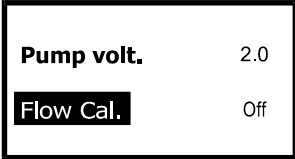
Objective	Action	Response
To access the Flow Calibration screen	At any screen after the password long press simultaneously 	
To change the parameter setting or value	short press 	
To move to the next parameter (and save the changed setting)	short press 	

SECTION 5: TROUBLESHOOTING

- 5.1 Introduction
 - 5.2 Who Should Perform Repairs
 - 5.3 Repair Level Supported
 - 5.4 How to Use This Section
 - 5.5 Obtaining Replacement Parts
 - 5.6 Troubleshooting Guide
-

5.1 INTRODUCTION

This section provides information for troubleshooting for the monitor isolating a failure of the monitor.

5.2 WHO SHOULD PERFORM REPAIRS

Only qualified service personnel should remove and replace components of the monitor. If your facility does not have qualified service personnel, contact your local distributor.

5.3 REPAIR LEVEL SUPPORTED

The monitor has the following replaceable components: CO₂ board, Flow System, Pump Assembly, Housing Components, LCD, 7-segment displays and Software Assembly.

The procedures for disassembling and replacing the above mentioned components are described in Section 7: *Disassembly Guide*.

5.4 HOW TO USE THIS SECTION

Failures of the Housing Components; front cover, rear cover, gas outlet, ON/OFF button and keypads, are determined by visually inspecting these components for cracks or deformations, and checking for mechanical failures.

Use the *Troubleshooting Guide* in Section 5.6 to isolate failures of the CO₂ board, Flow System, Pump Assembly, LCD and 7-segment displays. Once a failure has been isolated, refer to Section 7: *Disassembly Guide* for instructions for removing and replacing a component of the monitor.

5.5 OBTAINING REPLACEMENT PARTS

Your local distributor provides technical assistance information and replacement parts. Refer to parts by the part name listed in Section 13: *Spare Parts*.

5.6 TROUBLESHOOTING GUIDE

If you encounter a problem that cannot be resolved through a visual inspection, refer to Table 5-1 which provides a list of symptoms, probable causes, and recommended actions to correct the problem. It is recommended that corrective actions be performed in the order presented. For a symptom that is not listed in Table 5-1, contact your local distributor.

If an Advisory message is displayed on the LCD, refer to Table 5-2 for the indicated failure and corrective action. Caution messages appear on the display screen followed by !! and Advisory messages are followed by !.

Check in the Service Mode for any Event Messages and refer to Table 5-3 for the indicated failure and corrective action.

Table 5-1: Troubleshooting Guide

Symptom	Probable Cause	Corrective Action
The unit does not turn on when the ON/OFF button is switched ON when the unit is operated with batteries.	The battery pack is missing or is installed incorrectly.	Check if there is a battery pack in the monitor, if not, place one in the monitor. Be sure the battery pack is installed correctly.
	The battery pack's charge is low.	Install a fully charged battery pack; charge the empty battery pack.
	The battery pack's contacts are defective.	Install a new battery pack and check the monitor functions.
	The contacts for the battery pack on the CO ₂ board are defective or a CO ₂ board component has failed.	Connect the monitor to mains line power and if the monitor functions, replace the CO ₂ board.
The unit does not turn on when the ON/OFF button is switched ON when the monitor is connected to mains power.	The ON/OFF button has a mechanical defect.	Inspect the button for cracks, deformations or other damage. Replace with a new button.
	A CO ₂ board component has failed.	Replace with a new CO ₂ board.

Table 5-1: Troubleshooting Guide (Continued)

Symptom	Probable Cause	Corrective Action
The unit does not turn on when the ON/OFF button is switched ON when the monitor is connected to mains power.	The wall socket is not receiving power or is defective.	Check the wall socket for power supply or mechanical defects. If necessary, use a different wall socket.
	The AC adapter is defective.	Replace with new AC adapter.
	A CO ₂ board component has failed.	Replace with a new CO ₂ board.
One or more buttons on the upper or lower keypad do not work.	The keypad is defective.	Inspect the keypad for cracks, deformations or other damage. Replace with a new keypad.
	A CO ₂ board component has failed.	Replace with a new CO ₂ board.
No information is displayed on the LCD.	The contrast default value is set too low or high.	Check the contrast value in the Service Mode using the Contrast Cal. option and correct accordingly.
	An LCD component has failed.	Replace with a new LCD.
	A CO ₂ board component has failed.	Replace with a new CO ₂ board.
LCD Backlight does not come on when the monitor is placed in a dark environment.	The Power Management option is set at LOW .	Refer to the Handheld Capnograph Operator's manual to change the Power Management option to NORMAL or HIGH .
	An LCD component has failed.	Replace with a new LCD.
	A CO ₂ board component has failed.	Replace with a new CO ₂ board.

Table 5-1: Troubleshooting Guide (Continued)

Symptom	Probable Cause	Corrective Action
7-Segment Display does not light when the unit is functioning.	The Power Management option is set at LOW .	Refer to the Handheld Capnograph Operator's manual to change the Power Management option to NORMAL or HIGH .
	A 7-Segment display has failed.	Replace with new 7-Segment display.
	A CO ₂ board component has failed.	Replace with a new CO ₂ board.
Beeper does not beep.	One or more of the Alarm Silence options has been turned OFF .	Turn the respective alarm ON . Refer to the Handheld Capnograph Operator's manual.
	A CO ₂ component has failed.	Replace with a new CO ₂ board.

Table 5-2: Advisory Message

Message	Probable Cause	Corrective Action
Check Unit !	A CO ₂ board component has failed.	Check Event Messages screen in Service Mode.

Table 5-3: Event Messages

Event Message	Probable Cause	Corrective Action
CO2 board	- Component Failed	- Replace CO2 board
Flow	- Loose connections - Kinks or twists in tubing - Flow system blocked - Pump Malfunction - A CO2 board component has failed	- Inspect all tubing ends for loose connections and ensure tight connections - Straighten kinks and undo any twists in the tubing. - Check flow rate and if necessary change Flow System, refer to Section 6: <i>Flow Calibration Check</i> - Replace pump - Replace with a new CO2 board

SECTION 6: FLOW CALIBRATION CHECK

- 6.1 Introduction
 - 6.2 Flow Rate Check
 - 6.3 Flow Calibration Process
-

6.1 INTRODUCTION

Perform a Flow Calibration Check after replacing the Flow System and/or Pump. Flow Calibration Check includes Flow Rate Check and Flow Calibration Process.

6.2 FLOW RATE CHECK

To perform the Flow Rate Check, follow the steps below:

1. Connect the FilterLine to the Handheld Capnograph.
2. Turn on the monitor.
3. Connect the other end of the FilterLine to the Flow meter gas outlet.
4. Access the Flow Calibration screen of the Service Mode, refer to Section 4.3.3: *Flow Calibration*.
5. Check that the Flow Meter reading is 50 ± 5 ml/min. (at sea level)

If the Flow Meter reading is 50 ± 5 ml/min:

- 5a Perform Flow Calibration Process, refer to Section 6.3: *Flow Calibration Process*.

If the Flow Meter reading is not 50 ± 5 ml/min:

- 5b Change the pump voltage value until the flow rate displayed in the flow meter is 50 ± 5 ml/min, refer to Section 4: *Service Mode, Table 4-5: Accessing Flow Calibration*.

- 5c Perform Flow Rate Check

- 5d Perform Flow Calibration Process.

If you cannot set the flow rate to 50 ± 5 ml/min after adjusting the pump voltage value:

- 5e Change the Flow System, refer to Section 7.5: *Replacing the Flow System*.

- 5f Perform Flow Rate Check

- 5g Perform Flow Calibration Process.

If after changing the Flow System you still cannot set the flow rate display in the flow meter to 50 ± 5 ml/min:

- 5h Change the Pump, refer to Section 7.4: *Replacing the Pump*.

- 5i Perform Flow Rate Check

- 5j Perform Flow Calibration Process.

6.3 FLOW CALIBRATION PROCESS

To perform the Flow Calibration Process, refer to Table 6-1.

Table 6-1: Flow Calibration









Objective	Action	Response
To access Flow Calibration screen	Simultaneously long press  and 	
To select Flow Cal.	short press 	
To start Calibration	short press  short press 	 
Wait until either a Fail or Pass message is displayed		
If FAIL is displayed	Replace Flow System and/or Pump (refer to Section 5: <i>Troubleshooting</i>) and repeat above procedure	
If PASS is displayed	Exit Service Mode	

Table 6-1: Flow Calibration(Continued)

Objective	Action	Response
To reset and return to measuring mode	long press 	
To exit service mode and save event messages	Turn off the monitor	

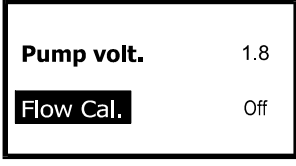
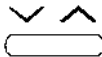
SECTION 7: DISASSEMBLY GUIDE

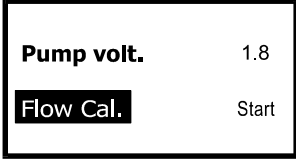
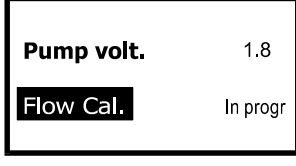
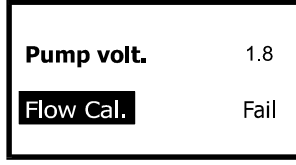
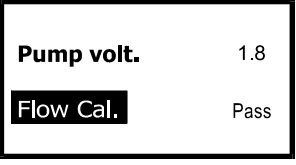
- 7.1 Introduction
 - 7.2 Opening the Handheld Capnograph Case
 - 7.3 Replacing the CO₂ Board
 - 7.4 Replacing the Pump Assembly
 - 7.5 Replacing the Flowing System
 - 7.6 Replacing the LCD and 7-Segment Display
 - 7.7 Replacing the Housing Components
 - 7.8 Updating the Software Version
-

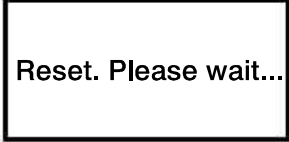
7.1 INTRODUCTION

The monitor can be disassembled and the following components can be replaced:

- CO₂ board
- Pump Assembly
- Flow System
- Housing components
- EPROM
- Liquid Crystal Display (LCD)
- 7-segment displays

Caution: Observe ESD (electrostatic discharge) precautions when disassembling and reassembling the monitor and when handling any of its components.

Use the following procedures to disassemble the monitor and replace parts as needed. Reassemble the monitor in reverse order. The manufacturer recommends that you follow the disassembly procedure in the order presented.

Note: After replacing the Flow System and/or Pump, perform a flow calibration check as described in Section 6: *Flow Calibration Check*.

Note: After reassembling any part of the monitor, be sure to complete the performance verification as described in Section 10: *Performance Verification*.

7.2 OPENING THE HANDHELD CAPNOGRAPH CASE

1. Be sure the monitor is disconnected from mains power and remove the battery pack from the monitor; push the release button at the bottom of the monitor and pull out the battery pack as shown in Figure 7-1.

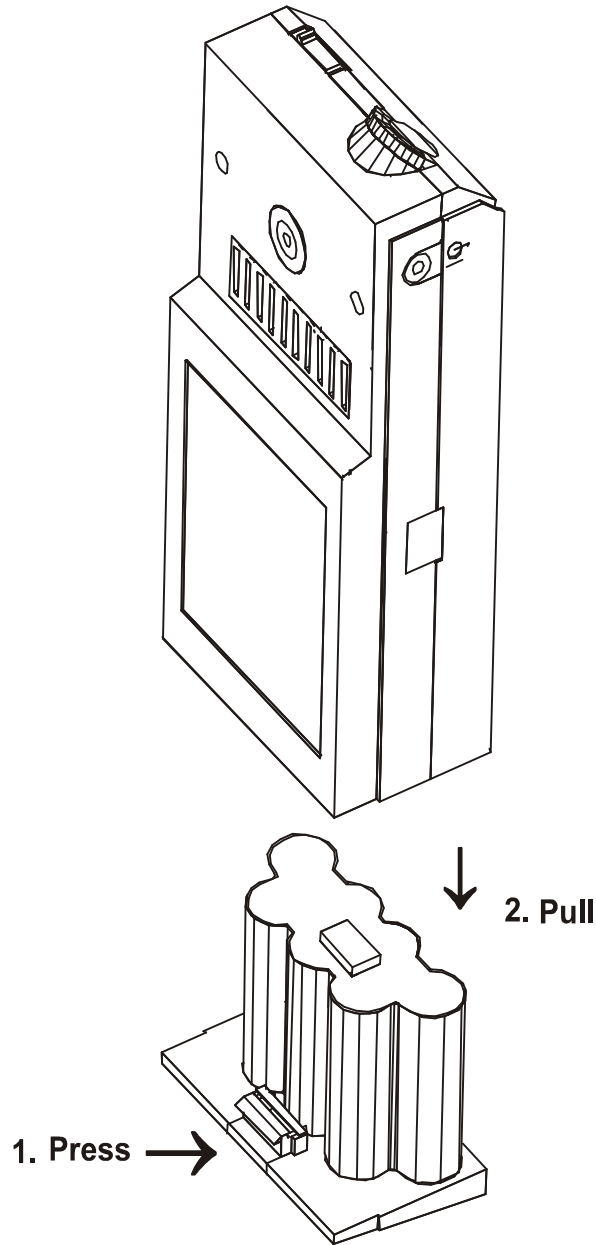

Figure 7-1: Removing the Battery Pack

2. Place the monitor on a clean, dry nonabrasive surface with the back of the monitor facing up.
3. Remove the two bottom and two back mounting screws from the rear panel of the monitor as shown in Figure 7-2.

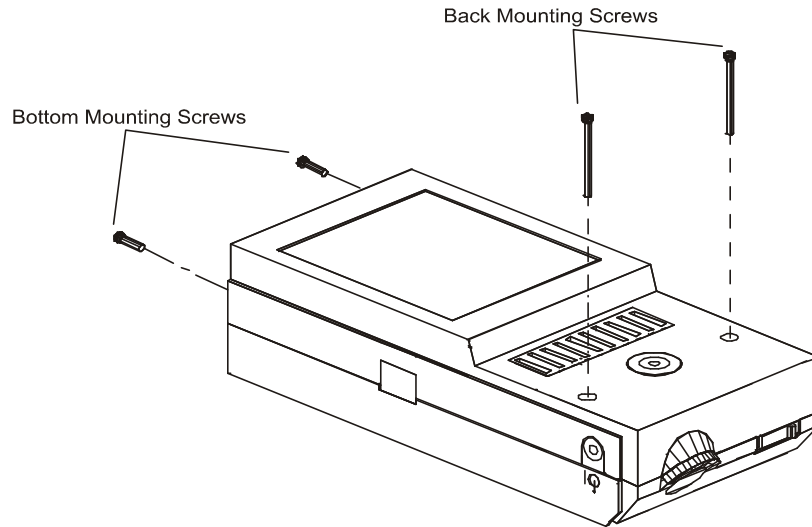

Figure 7-2: Removing Mounting Screws

4. Carefully lift the rear case cover up as shown in Figure 7-3.

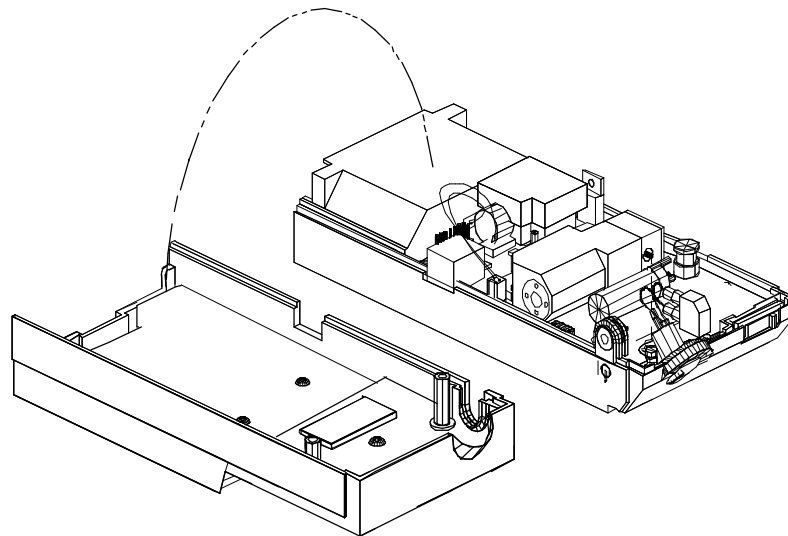

Figure 7-3: Separating Rear and Front Covers

7.3 REPLACING THE CO₂ BOARD

1. Open the monitor case as described in Section 7.2.
2. Remove the two CO₂ board mounting screws.
3. Remove the CO₂ connector screw from the CO₂ input connector.
4. Remove the ON-OFF button and save for reassembly.
5. Remove the gas outlet from the tubing and save for reassembly.
6. Remove the CO₂ board and replace with a new CO₂ board and reassemble in reverse order.

Warning: The scrubber on the CO₂ board is a lithium based compound. Follow local governing ordinances for disposal.

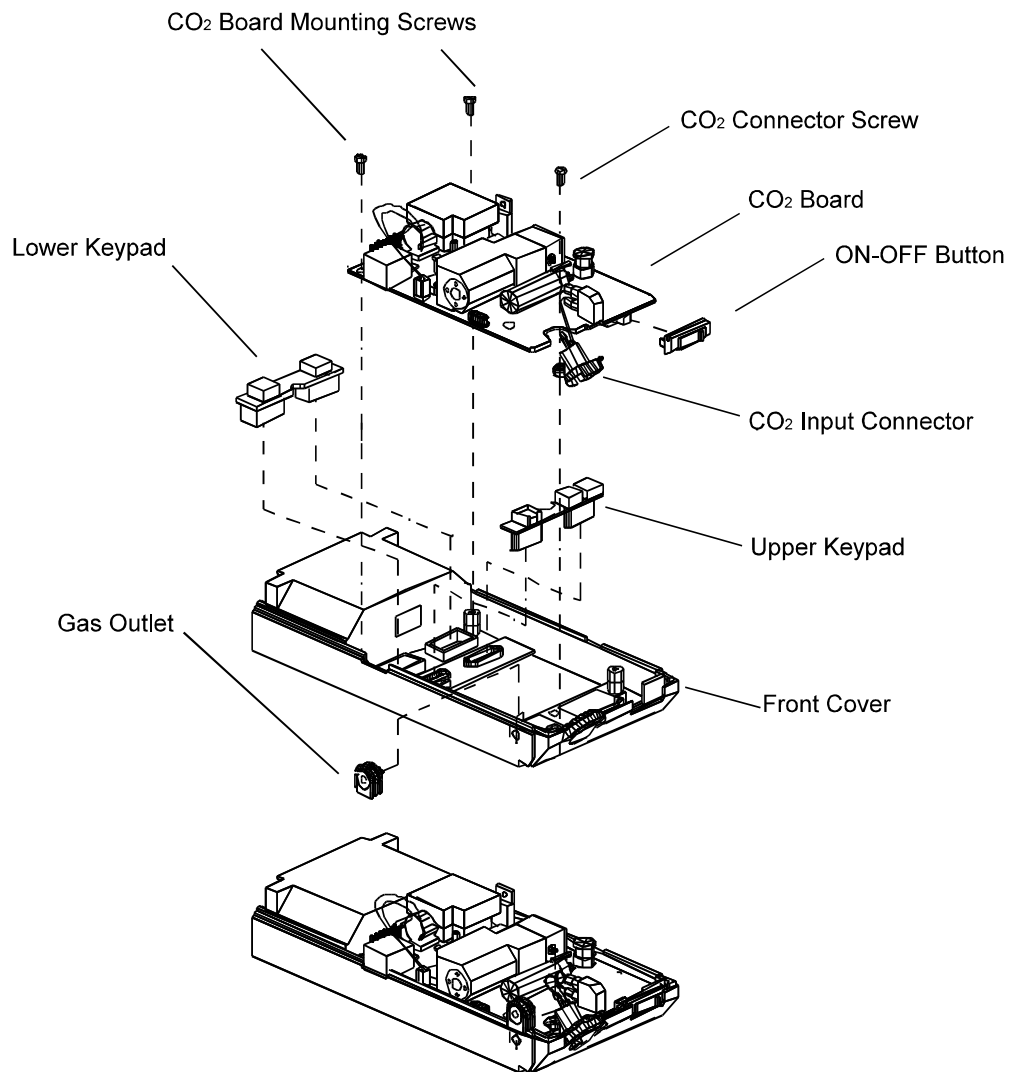

Figure 7-4: Replacing CO₂ Board and Housing Components

7.4 REPLACING THE PUMP (REFER TO FIGURE 7-5)

1. Open the monitor case described in Section 7.2.
2. Remove the damping cover from the pump.
3. Locate the two tubings, Main line and Exhaust line, connected to the pump, refer to Figure 7-6.
4. Locate the purple Main line restrictor and the green Exhaust line restrictor.
5. Disconnect both tubings from their restrictors.

Note: Both restrictors must remain with their flow system lines attached to the CO₂ board.

6. Disconnect the pump connector from it's CO₂ board socket.
7. Remove the CO₂ board from the front cover, refer to Section 7.3.
8. Unscrew and remove the pump mounting screws.
9. Remove the lower damping and damping holder.
10. Remove the pump and the upper damping .
11. Place the new Pump.
12. Reassemble the unit, using the new assembly parts, in reverse order.

Note: Before replacing the pump mounting screws, first dip them into Loctite[®] glue or any other threadlocker glue. Carefully twist the screws into the lower damping, gently pressing against the CO₂ board..

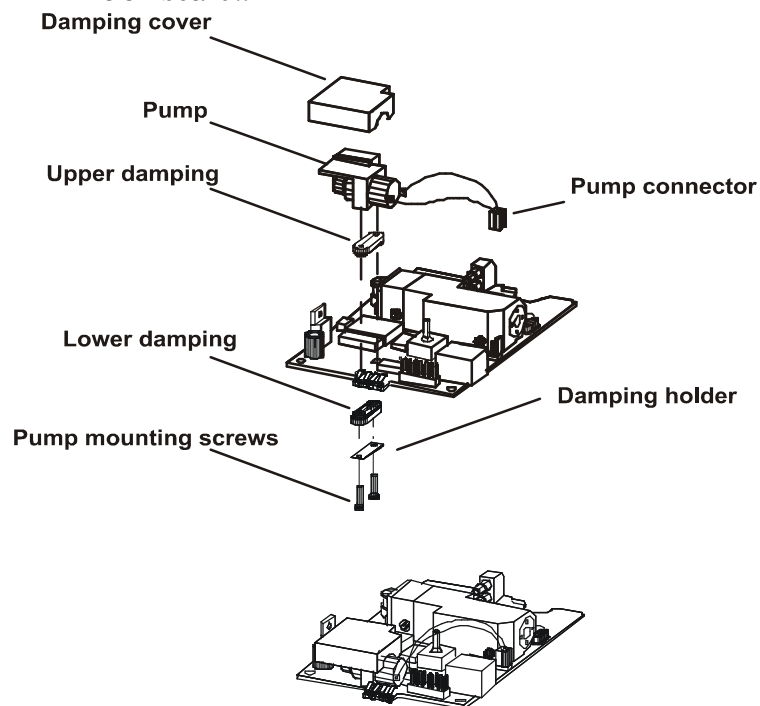

Figure 7-5: Replacing the Pump

7.5 REPLACING THE FLOW SYSTEM

1. Open the monitor case as described in Section 7.2.

The Flow System has 5 lines, refer to Figure 7-6.

Two lines go from the pump:

- Main line
- Exhaust line

Three lines go from the solenoid :

- Zero line
- Input Line1
- Input Line2

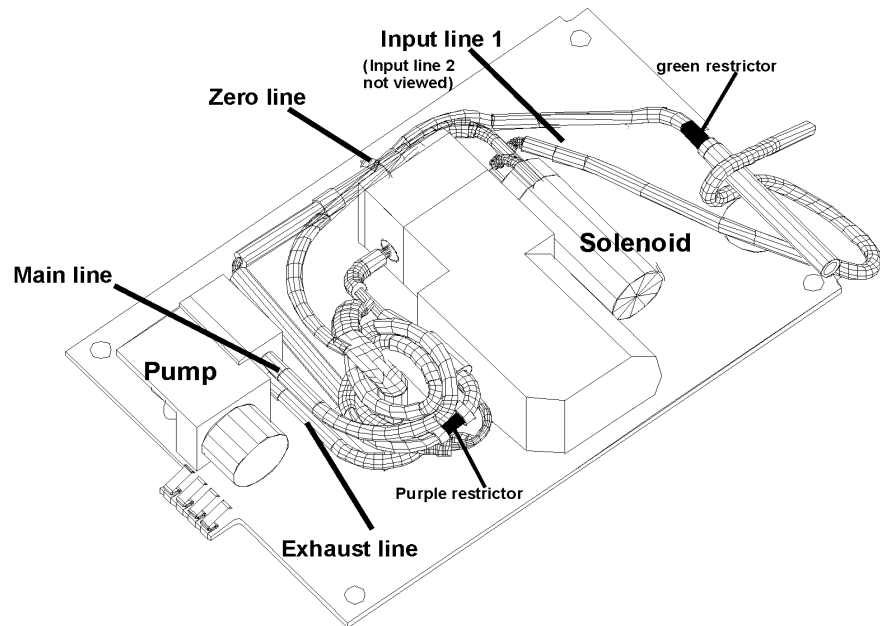

Figure 7-6: Flow System

7.5.1 Replacing the lines to the pump

7.5.1.1 Replacing the Main line (Refer to Figure 7-7)

1. Locate the purple restrictor.
2. Carefully disconnect the main line from the tubing connected to the pump, leaving the purple restrictor in the main line.
3. Remove the tubing from the CO₂ sensor.
4. Remove the tubing from the pressure sensor.

Note: When replacing the main line, in order to fit the main line on the board without twists and kinks, coil the tubing around the pressure sensor (refer to Figure 7-8).

5. Reassemble the new Main line in reverse order.

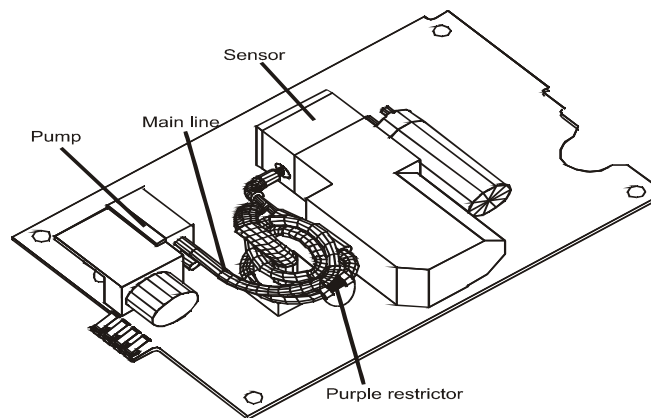

Figure 7-7: Main line

7.5.1.2 Replacing the Exhaust line (Refer to Figure 7-8)

1. Locate the green restrictor.
2. Carefully disconnect the Exhaust line, at the green restrictor, from the tubing connected to the pump. Leave the green restrictor in the exhaust line.
3. Reassemble the new Exhaust line in reverse order.

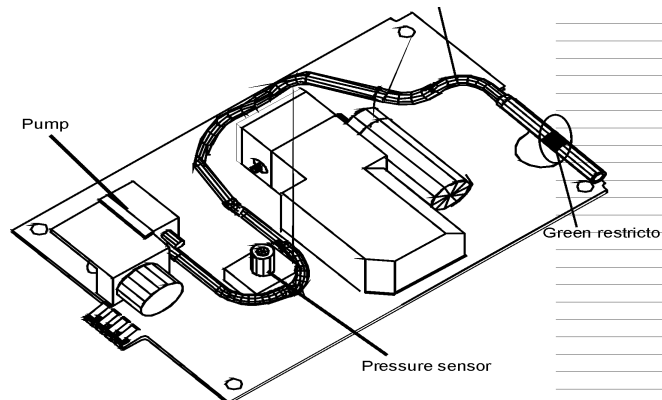

Figure 7- 8: Exhaust line

7.5.2 Replacing the lines to the solenoid (Refer to Figure 7-9)

7.5.2.1 Removing lines to the solenoid

1. Carefully disconnect the Zero line from the solenoid.

Warning: The scrubber on the Zero line is a lithium based compound. Follow local governing ordinances for disposal.

2. Remove Input line 1 from the solenoid and the other end from the FilterLine input connector.
3. Remove Input line 2 from the solenoid and the other end from the sensor connector.

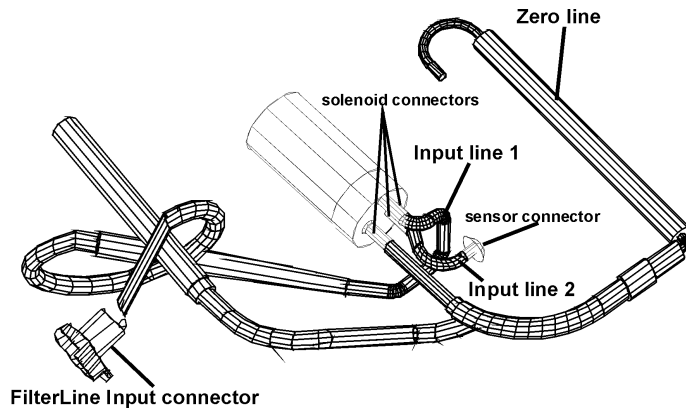

Figure 7-9: Lines to Solenoid (Zero line, Input line 1, Input line 2)

7.5.2.2 Reassembly of the new solenoid lines.

1. Attach the new Input line 1 to the upper solenoid connector.
2. Locate the lower solenoid connector which is closest to the sensor and attach the new Input line 2 to this connector.
3. Bring the Input line 2 tubing over Input line 1, and attach to the sensor connector.
4. Lead the Input line 1 under the FRS cables (connected to the FilterLine input connector, not viewed in Figure 7-9) and connect to the FilterLine input tubing connector.
5. Connect the Zeroline to its solenoid connector and place the scrubber close to the pump under the coiled main line tubing, refer to Figure. 7-10.

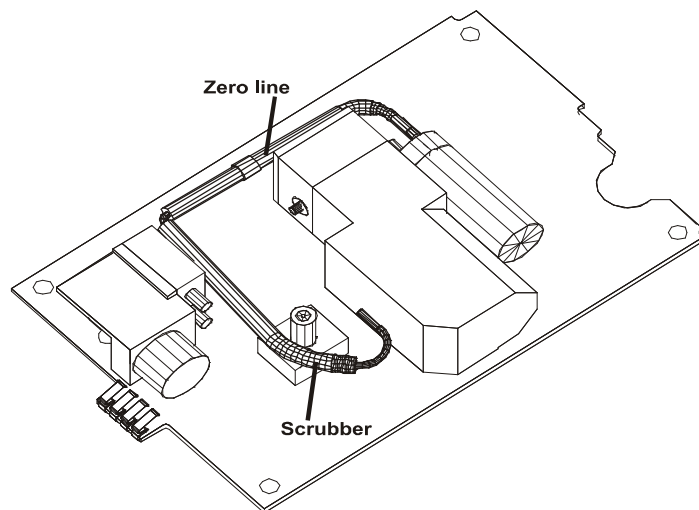

Figure 7-10: Zero line

7.6 REPLACING LCD AND 7-SEGMENT DISPLAY (REFER TO FIGURE 7-11)

7.6.1 Replacing the LCD

1. Remove the CO₂ board as described in 7.3.
2. Unscrew and remove the four LCD mounting screws.
3. Carefully remove the LCD and replace with a new LCD.

7.6.2 Replacing the 7-Segment Display

1. Remove the CO₂ board as described in Section 7.3.
2. Carefully remove the faulty 7-segment display from its socket and replace with a new 7-segment display. Note the correct orientation of the 7-segment display when replacing it.

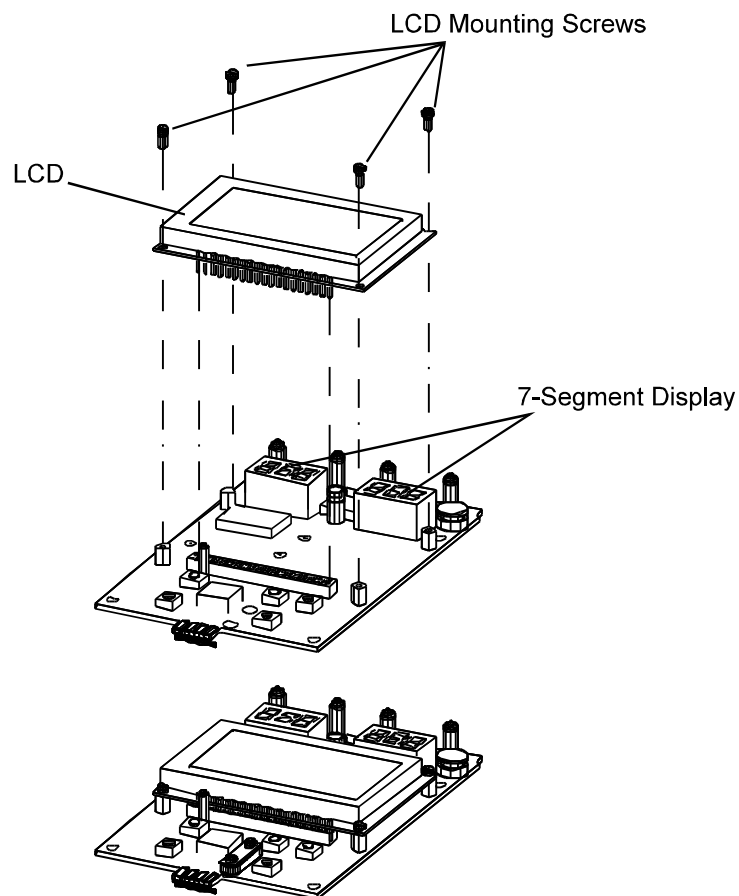

Figure 7-11: Replacing LCD and 7-Segment Display

7.7 REPLACING HOUSING COMPONENTS

The Housing kit includes the following replaceable components:

- Front cover
- Rear cover
- ON/OFF switch
- Upper Keypad (Alarm silence button and Contrast/Value change button)
- Lower Keypad (Print/Home button and Next/Menu button)
- Gas outlet
- Screws
- Washers

Note: When reassembling the monitor after replacing any part, be sure to follow the disassembly steps in reverse order.

7.7.1 ON/OFF Button and Gas Outlet (Figure 7-4)

1. Open the monitor as described in Section 7.2.
2. Remove the gas outlet from the tubing and replace with a new gas outlet.
3. Remove the ON/OFF button from the CO₂ board as described in Section 7.3 and replace with a new button.

7.7.2 Keypads (Figure 7-4)

1. Open the monitor as described in Section 7.2.
2. Remove the CO₂ board as described in Section 7.3.
3. Remove the old keypad. When replacing the new keypad, be sure the icons are facing the correct direction, refer to Figure 1-1.

7.7.3 Front Cover (Figure 7-4)

1. Open the monitor as described in Section 7.2.
2. Remove the CO₂ board as described in Section 7.3.
3. Remove the keypad and ON/OFF button. Place them in the new front cover. When replacing the keypad, be sure the icons are facing the correct direction, refer to Figure 1-1.
4. Place the CO₂ board in the new cover.

7.7.4 Rear Cover (Figure 7-3)

1. To replace the rear cover, open the monitor as described in Section 7.2. and replace the old rear cover with a new rear cover.

7.8 UPDATING SOFTWARE VERSION

Caution: Observe ESD (electrostatic discharge) precautions when disassembling and reassembling the monitor and when handling any of the components of the monitor.

1. Open the monitor as described in Section 7.2.
2. Remove the EPROM from its socket (on the CO2 board) using an IC extractor, refer to Figure 7-12.
3. Insert the new EPROM.

Note: When replacing the EPROM, be sure it is positioned correctly.

Note: When operating the monitor for the first time after updating the software version, the warm-up and the self-test periods will be longer than usual.

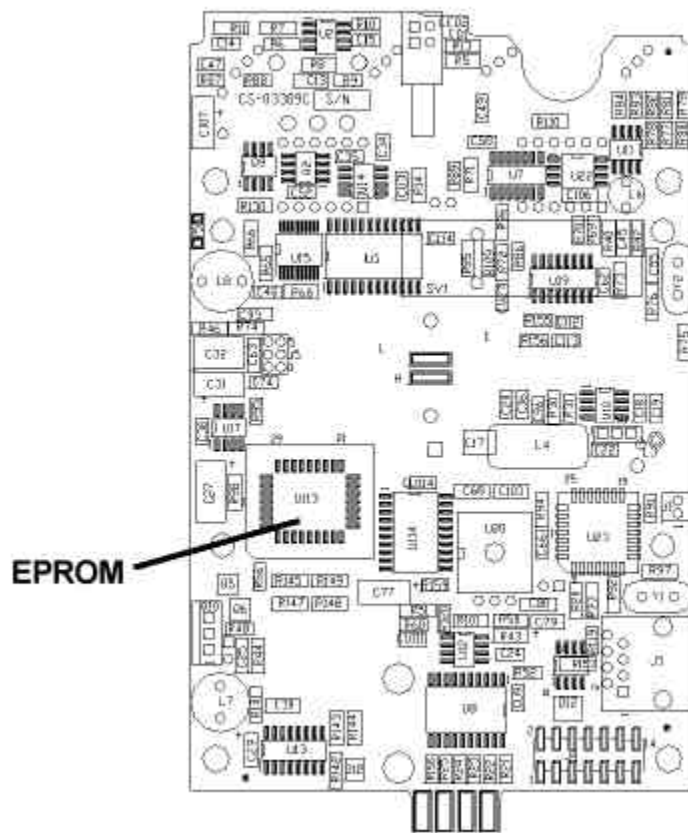

Figure 7-12: Replacing EPROM

SECTION 8: ELECTRICAL SAFETY TESTS

8.1 Electrical Safety Tests

8.1 ELECTRICAL SAFETY TESTS

Do not return the monitor to the user until the conditions in the following “Warning” statement are met.

Warning: After servicing the monitor, always verify product performance per the procedures in Section 10: *Performance Verification* and perform any safety tests required by local regulatory bodies or mandated by your institution.

SECTION 9: PERIODIC MAINTENANCE

9.1 Periodic Maintenance

9.1 PERIODIC MAINTENANCE

Periodic maintenance is recommended according to operating hours (refer to section 4.2 "Service Level 1"):

The Pump and Flow System should be replaced every 7,000 operating hours.

For replacing the pump, refer to section 7.5 "Replacing the Pump".

For replacing the flow system, refer to section 7.6 "Replacing the Flow System".

The monitor should be returned to the manufacturer for periodic maintenance every 14,000 operating hours.

SECTION 10: PERFORMANCE VERIFICATION

- 10.1 Flow System Leak Check
 - 10.2 Performance Verification Procedure
-

The performance of the monitor must be verified after all service procedures. Perform all procedures in this section to verify the correct functioning of the monitor.

10.1 FLOW SYSTEM LEAK CHECK

Perform the Flow System Leak Check after all service procedures described in this manual.

10.1.1 Flow System Leak Check Procedure

1. Connect the vacuum manometer to the Leak Test Jig as shown in Figure 10-1.

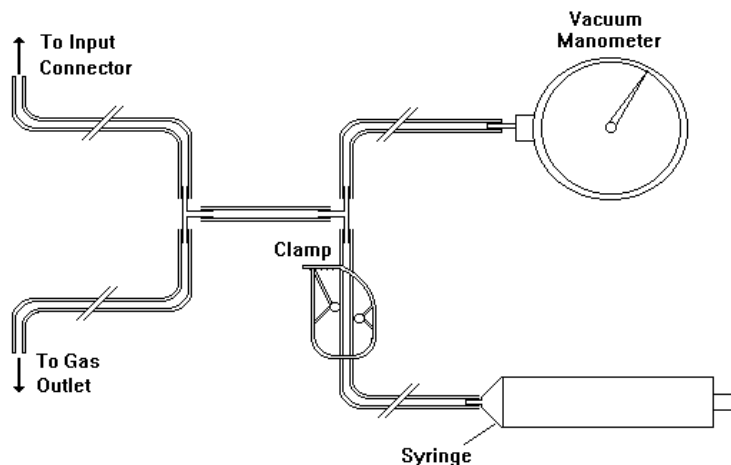

Figure 10-1: Leak Test Jig Connection

2. Open the Leak Test Jig clamp and empty the syringe's contents.
3. Connect the open-ended tubing (as shown in Figure 10-1) of the Leak Test Jig to the Gas Outlet of the monitor.
4. Connect the other open-ended tubing of the Leak Test Jig to the CO₂ input connector.
5. Pull the syringe valve out until the pressure drops (as displayed on the vacuum manometer) to approximately -300 mBar (or equivalent) and close the clamp.
6. Wait 30 seconds.
7. The change in reading should be less than 20 mBar (or equivalent).

8. If the reading drops more than 20 mBar, there is a leak in the flow system.
 - Open the unit.
 - Check for loose fittings and if any are found, reconnect them.
 - Repeat the above process (steps 1-7).
 - If the reading continues to show a drop of more than 20 mBar, replace the Flow System, refer to Section 7-5.

10.2 PERFORMANCE VERIFICATION PROCEDURE

Verify the performance of the monitor using the following procedure.

1. Connect the monitor to mains supply using the AC adapter.
2. Connect the FilterLine to the monitor.
3. Turn **ON** the monitor.
4. The Initialization Screen appears and the Self-Test bar fills, refer to Figure 10-2.
5. Verify that an audio tone sounds. This verifies proper operation of the Alarm interfacing. Check that the LEDs on the alarm bar turn red, yellow and then off. The 7-segment display shows 8s moving from left to right.
6. After initialization, the monitor automatically goes to Measuring Mode. The message **CO₂ Warmup** appears on the Silent Advisory Message area, refer to Figure 10-3.
7. After CO₂ Warmup, verify that the message changes to **Ready**.



Figure 10-2:
Initialization Screen

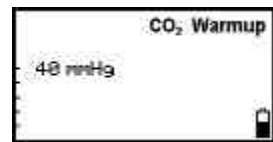

Figure 10-3: Measuring Mode

Note: If BTPS is on, then the message will read **BTPS ON-Ready**.

8. Disconnect the FilterLine and verify that the message **FilterLine** is displayed on the Silent Advisory Message Area and verify that the pump stops.
9. Reconnect the FilterLine and verify that the message **FilterLine** disappears and the pump is operating.

- Verify that all buttons on the unit work properly. Refer to the Quick Guide for their applications, see Figure 10-4.







Quick Guide		
Power On	Short Press	Long Press
	Changes Displays / Selects Parameters	Accesses Menus
	Event Mark	Home / Erase Trend
	Changes Values / Contrast	Quick Scroll
	Sound ON / OFF	Accesses Alarm Menu
 + 	Data Transfer ON / OFF	

Figure 10-4: Quick Guide

- Verify the CO₂ Calibration Check process functions. Follow the procedure as described below. When completed, return to the Measuring Mode screen.

CO₂ Calibration Check

Caution: Do not check CO₂ values from the measuring mode if the BTPS setting is ON (factory default). This mode corrects the CO₂ value for BTPS. The calibration check mode disables this correction.

In order to ensure accuracy, a CO₂ calibration check needs to be done once a year. Calibration gas and a FilterLine are needed for this procedure. Start the process from the Interface Test Screen (refer to Table 4-2) as follows in Table 10-1.

Note: Connect the FilterLine to the monitor before starting CO₂ Calibration Check. Use the calibration kit (5% gas in air and connecting means) supplied and approved by Oridion Medical 1987 Ltd.

Note: If the CO₂ Calibration Check is performed on a battery powered device, ensure that the batter is fully chaged prior to calibration

Table 10-1: CO₂ Calibration Check

Objective	Action	Result								
Access CO ₂ Calib.	short press (x3) 	<table border="1"> <tr> <td>HMI Test</td> <td>Off</td> </tr> <tr> <td>Light Detector</td> <td>1</td> </tr> <tr> <td>Contrast Cal.</td> <td>Off</td> </tr> <tr> <td>CO₂ Calib.</td> <td>Off</td> </tr> </table>	HMI Test	Off	Light Detector	1	Contrast Cal.	Off	CO₂ Calib.	Off
HMI Test	Off									
Light Detector	1									
Contrast Cal.	Off									
CO₂ Calib.	Off									

Table 10-1: CO₂ Calibration Check (Continued)







Objective	Action	Result
Change option to Start .	short press 	
	No action required	
	No action required	
Prepare for Cal. Check	Connect the FilterLine to the calibration gas.	
Check the measured values shown in Vol% in the EtCO ₂ digital display.	Press the gas valve for 15 seconds until the readings stabilize.	
<p>Calibration is not required if the measured value is the same as the concentration of the calibration gas ($\pm 0.3\%$ Vol.%) e.g. Concentration of calibration gas used is 5% (CO₂); the measured value should be between 4.7%-5.3%, therefore, calibration is not required.</p>		
To reset and return to measuring mode (automatically erasing event messages)	long press 	

Table 10-1: CO₂ Calibration Check (Continued)

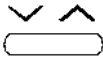
Objective	Action	Result
To exit service mode and save event messages	Turn off the monitor.	
If the reading is outside these limits, calibration is required. Refer to Table 10-2 for the Calibration Process procedure.		

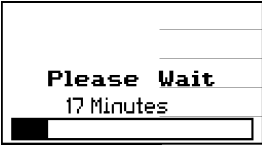
Calibration Process

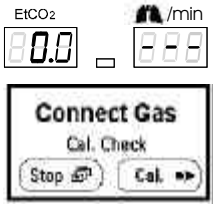
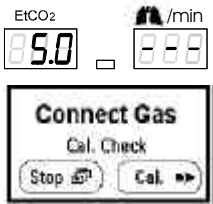
If calibration is required, perform the Calibration Process (after performing Calibration Check) as shown in Table 10-2

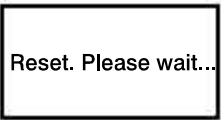
Table 10-2: Calibration Process









Objective	Action	Result
To start Calibration Process after calibration check.	No action required.	
To activate Calibration Process.	long press →	
To adjust the display value to the gas concentration you are using.	short press 	
To start calibration.	Press the gas valve and long press →	
	Continue pressing the gas valve until the Disconnect Gas appears.	
Monitor performs an internal calculation.	Disconnect Gas from the FilterLine.	
Calibration succeeded.	No action required.	

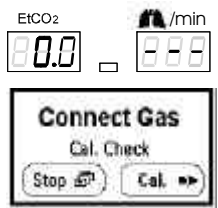

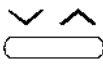
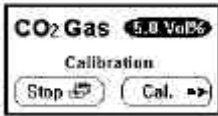
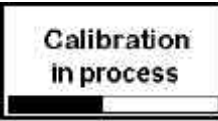
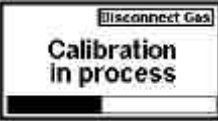
Table 10-2: Calibration Process (Continued)

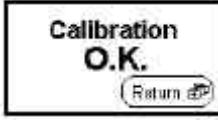
Objective	Action	Result
Return to calibration check mode.	long press 	
To reset and return to measuring mode	long press 	
To exit service mode and save event messages	Turn off the monitor.	

Calibration Errors

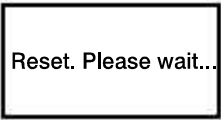
Table 10-3 describes calibration problems that can occur, the message displayed and the corrective action.

Table 10-3: Calibration Process - Troubleshooting

Message	Possible Causes	Action
	<ul style="list-style-type: none"> Gas concentration does not match the concentration value selected in the first calibration screen. Problems with gas sampling Flow system problems (purging, blockage or no FilterLine) 	Check setup, correct probable causes, and recalibrate unit as above.
	<ul style="list-style-type: none"> CO₂ Sensor problem Calibration process exceeds 3 minutes 	<ul style="list-style-type: none"> Contact your local distributor. Restart. If the problem persists, contact your local distributor.

- Disconnect the monitor from the AC mains supply. Verify the unit continues to work from its battery pack and the battery icon appears

on the lower right corner of the display.

13. Reconnect the monitor to mains power with the AC adapter. Verify that the unit functions, and the plug icon appears.

Note: If the battery pack has a low charge level, the battery icon will appear instead of the plug. The battery icon will fill indicating the battery charging process.

To verify printing functions:

14. Adjust the printer to the following communication settings:

Input	Serial
Data Length	8 bits
Parity Settings	None
Baud	9600 bps
15. Using the Communication Adapter Kit, connect the printer to the monitor, refer to Figure: 10-5.

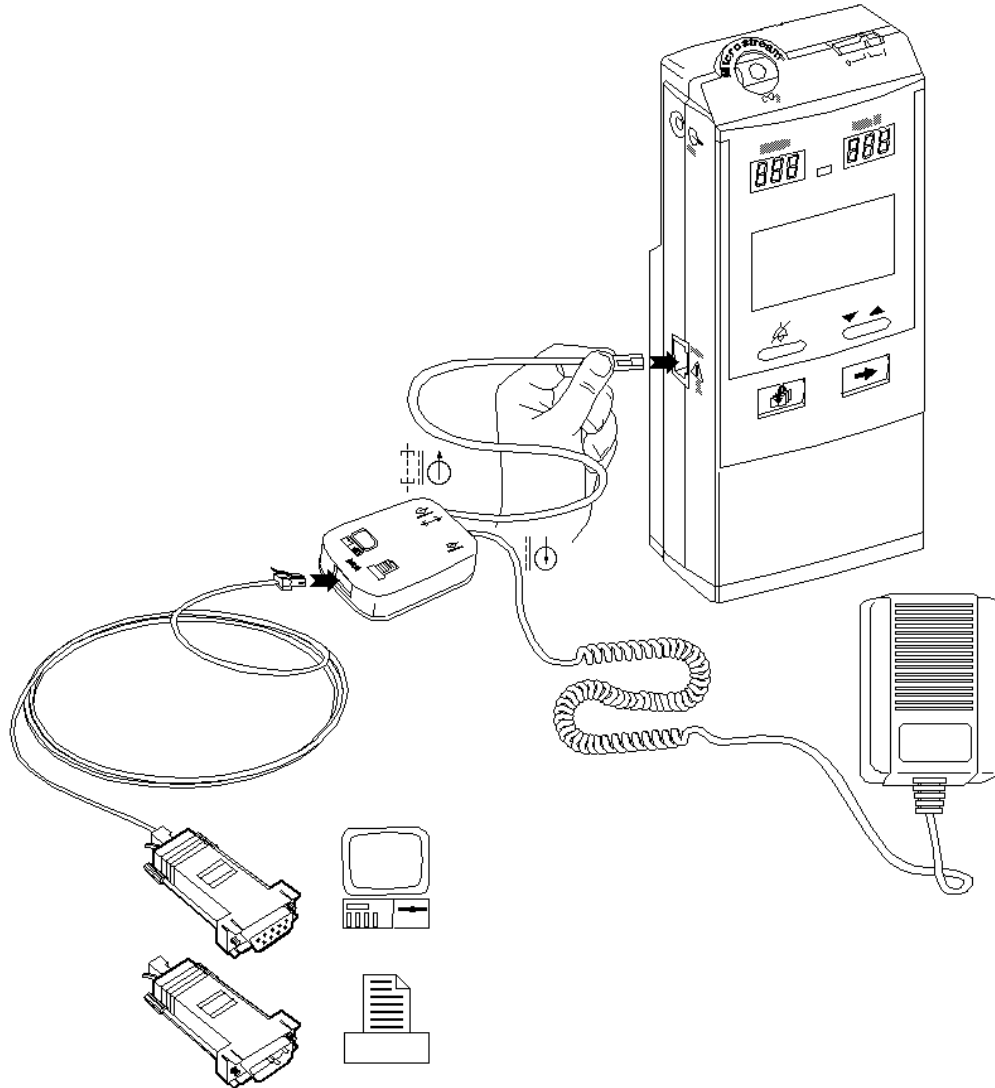
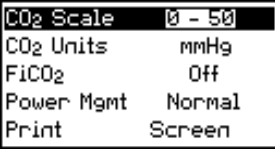
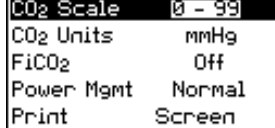

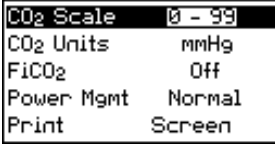

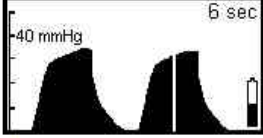

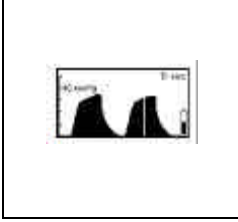

Figure 10-5: Connecting the monitor to Printer/PC with Communication Adapter Kit

16. Turn the printer **ON** and select on-line mode.

17. Access the monitor print functions as described in Table 10-4 below:

Table 10-4: Accessing Handheld Capnograph Print Functions

Objective	Action	Result
To access the <i>Instrument Setup</i> menu (first access the <i>Alarm Limits</i> menu from any measuring display)	long press (x2) ➔	
To select Print	short press (x4) ➔	
Be sure the Print option shows Screen ; if it doesn't, change to the Screen option	short press 	
To return to Measuring Mode	long press 	
To print	long press simultaneously  and ➔	 (printout)

SECTION 11: PACKING FOR SHIPMENT

- 11.1 General Instructions
 - 11.2 Packing Handheld Capnograph in Original Carton
 - 11.3 Packing in a Different Carton
-

11.1 GENERAL INSTRUCTIONS

To ship a monitor or one of its components for any reason, follow the instructions in this section. Failure to follow the instructions in this section may result in loss or damage not covered by any applicable manufacturer warranty.

Pack the monitor or component(s) carefully. If available, use the original carton and packing materials and follow the instructions in “Packing monitor in Original Carton.” If the original shipping carton and material are not available, use other suitable shipping materials and container and follow the instructions in “Packing in a Different Carton.”

Prior to shipping the monitor or a component, contact your local representative for a Returned Material Authorization (RMA) number. Mark the shipping carton and any shipping forms with the RMA and the monitor’s serial number.

Caution: Observe ESD (electrostatic discharge) precautions when packing any monitor components.

11.2 PACKING HANDHELD CAPNOGRAPH IN ORIGINAL CARTON

If the original carton and packing material are available, repack the monitor as follows. (Refer to Figure 11-1.)

1. Place the unit in a plastic bag. Place it into the corresponding space, in the original foam padding, with the front panel facing up.
2. Place the foam padding cover over the top of the unit.
3. Seal the carton with packing tape.
4. Label the carton with the correct shipping address, return address and RMA number.

11.3 PACKING IN A DIFFERENT CARTON

If the original carton and packing material are not available or if shipping any monitor component not in its original carton:

1. Place the monitor in a plastic bag or component in a plastic anti-static bag.
2. Locate a corrugated cardboard shipping carton (approximately the size of the monitor or component) with at least 200 pounds per square inch (psi) bursting strength.
3. Fill the bottom of the carton with at least 2 inches of packing material.

Section 11: Packing For Shipment

4. Place the bagged monitor or component on the layer of packing material and fill the box completely with packing material such that there is at least 2 inches of packing material around all sides of the item.
5. Seal the carton with packing tape.
6. Label carton with shipping address, return address and RMA number.

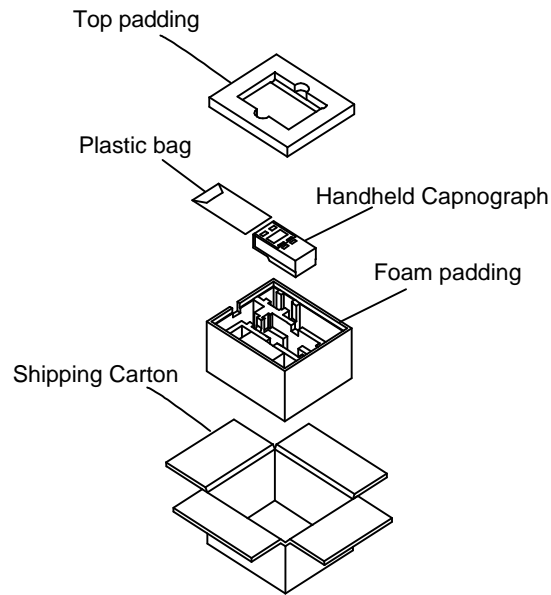

Figure 11-1: Packing the Handheld Capnograph in Original Packing

SECTION 12: SPECIFICATIONS

- 12.1 Physical
 - 12.2 Environmental
 - 12.3 Safety Standards
 - 12.4 Performance
 - 12.5 Power Specifications
 - 12.6 Components and User Interface
-

12.1 PHYSICAL

12.1.1 Size

206 mm H x 88 mm W x 53 mm D (8.11”H x 3.46” W x 2.06”D)

12.1.2 Weight (including battery pack)

750 grams (1.66 lb.)

12.1.3 Noise Emission

maximum 45 dB(a)

12.2 ENVIRONMENTAL

12.2.1 Temperature

Operating	0°C to 45°C (32°F to 113°F)
Storage	-35°C to 70°C (-31°F to 158°F)

12.2.2 Relative Humidity

10 to 95% (noncondensing)

12.2.3 Pressure and Altitude (for operating and storage).

Pressure	430 mmHg to 795 mmhg
Altitude	-380m to 4,570m (-1,250 ft. to 15,000 ft)

12.3 SAFETY STANDARDS

The monitor was designed to comply with EN60601-1/1990, A1/1993, A2/1995, EN60601-1-1/1992, A1/1996, UL 2601-1 and CSA 22.2 No. 601.1-M90, EN864/1997.

12.4 PERFORMANCE

Sampling Rate	50 ±7.5 ml/min
CO₂ Range	0-99 mmHg (0-13.2 kPa and 0-13.0 Vol%) at sea level
Accuracy EtCO ₂ readings	<p>Accuracy From power-up until steady state is reached, the CO₂ reading accuracy is: 0 - 38 mmHg: (+ 4 mmHg) 39 - 99 mmHg: (+ 12% of reading)</p> <p>The CO₂ reading reaches its steady state accuracy 20 minutes after power up. 0 - 38 mmHg: (+ 2 mmHg) 39 - 99 mmHg: (+5% of reading + 0.08% for every 1 mmHg above 40mmHg)</p> <p>Equivalent values for kPa and Vol% Frequency Response: 0-150 breaths/min.</p>
Respiration Rate	
Warm-up Time	30 seconds (typical)
Frequency Response	EtCO ₂ accuracy is maintained up to 80 breaths/min. (For maintaining accuracy for respiration rate over 60 bpm, use the neonatal mode.) From 81 to 150 bpm accuracy is ±12%, if the EtCO ₂ is higher than 18.8 mmHg in neonatal mode.
System Response Time (delay time)	2.45 seconds (typical), 2.9 seconds maximum
Ambient Pressure	Compensated internally - automatic
Alarms	EtCO ₂ high*, EtCO ₂ low*, FiCO ₂ high*, No Breath message

* The accuracy of these alarms is the same as the accuracy of the EtCO₂ readings.

12.5 POWER SPECIFICATIONS

12.5.1 External Power Source

12V DC Medical Grade Adapter

12.5.2 Internal Power Source

Ni-MH Rechargeable Battery Pack 7.2V 2.1 A/h (intended for continuous operation)

Operating Time (fully charged)	Between 3 and 6 hours, depending on power management. These values reflect the performance of a new battery; age and usage will degrade capacity.
Recharging Period	Approximately 4.5 hours internal recharging
Charger Type	Internal

12.6 COMPONENTS AND USER INTERFACE

12.6.1. Displays

Graphic LCD display	(128 x 64 dots) with LED backlight dimension 75 mm x 53 mm.
Two numeric fields	3 digits each, using 7-segment LED dimension 22mm x 14 mm.
Two-color alarm bar	yellow, red

12.6.2 Controls and Indicators

Front Panel	ON/OFF switch; Alarm Silence button; Contrast/ Value change button; Event/Home button; Next/ Menu button.
--------------------	---

12.6.3 Connections

Front Panel	CO ₂ Input connector
Rear Panel	Clamp connector
Side Panel	Power Supply/Communication Adapter Port, Gas output connector

SECTION 13: SPARE PARTS

13.1 Spare Parts List

13.1 SPARE PARTS LIST

Spare parts are shown below in Table 13-1. For spare part numbers contact your local distributor.

Table 13-1: Spare Parts List

Item	Description
1	CO ₂ board - includes electronic board, sensor, pump and scrubber, solenoid, LCD, 7-segment display, flow system, CO ₂ input connector, software EPROM and screws.
2	Software Assembly - includes EPROM chip and last updated software version.
3	Housing Kit - includes front cover, rear cover, ON/OFF button, keypads, gas outlet, screws
4	7-Segment Digital Display (x2)
5	LCD Assembly - Graphic Display Screen and PC driver
6	Calibration Gas (5% CO ₂ in air) and FilterLine
7	Leak Test Jig - vacuum test accessories
8	Communication Adapter Kit
9	Battery Pack
10	Pump Assembly
11	Flow System

GLOSSARY OF TERMS

BIT:	Built in Tests.
BTPS:	Body Temperature, Pressure and Saturation Compensation. Where Body Temperature is <i>assumed 37°C with vapor pressure 47mmHg</i> The Calculations are made according to: $P_{CO_2} = F_{CO_2} \times (P_b - 47)$ Where: F_{CO_2} is the Fractional concentration of CO ₂ in Dry gas, $F_{CO_2} = \% CO_2 / 100$ P_b = the ambient pressure P_{CO_2} = the partial pressure of CO ₂ at BTPS
EPROM:	Erasable Programmable Read Only Memory.
ESD:	Electrostatic Discharge.
EtCO₂:	End Tidal Carbon Dioxide: amount of CO ₂ present at the end of the exhalation.
FiCO₂:	Fractional Inspired Carbon Dioxide: amount of CO ₂ present during inhalation.
FRS:	FilterLine Recognition Safeguard.
LCD:	Liquid Crystal Display.
HMI:	Human Machine Interface.
Respiration Rate:	Number of respiratory cycles (inhalation and exhalation) per minute.
7-segments LED:	Graphic display of seven segments of light emitter diodes.
Solenoid:	2-way electro-pneumatic valve controlling the directional flow either from the patient or from the CO ₂ Scrubber (during Autozero).
Scrubber:	Lithium compound CO ₂ absorber.

NELLCOR

Tyco Healthcare Group LP
Nellcor Puritan Bennett Division
4280 Hacienda Drive
Pleasanton, CA 94588 USA

Authorized Representative
Tyco Healthcare UK LTD
154 Fareham Road
Gosport PO13 0AS, U.K.

