

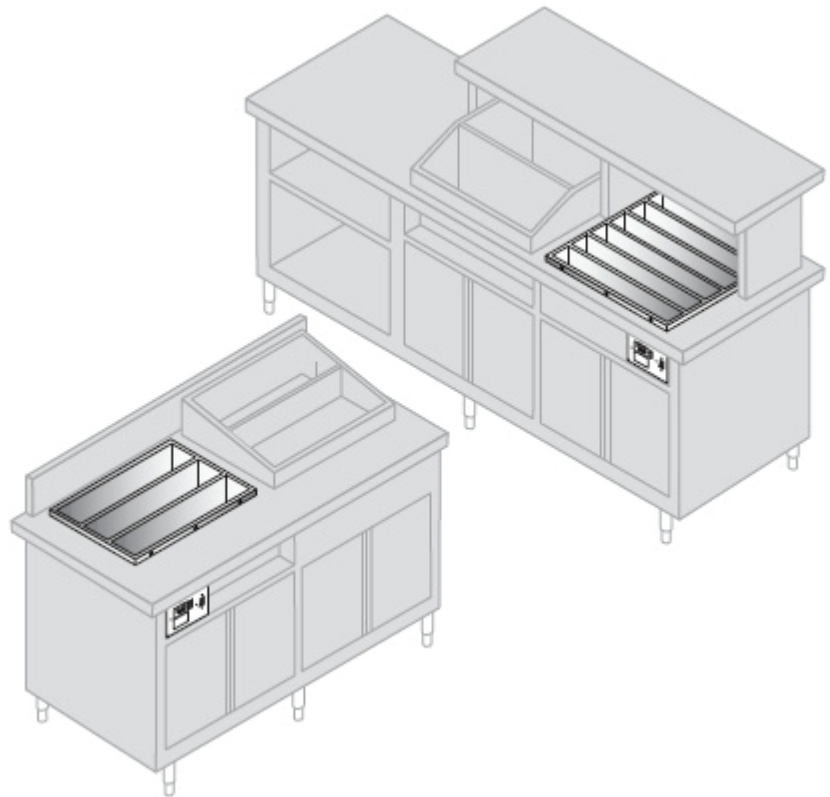

# Service Manual

## DRY CHANNEL

### MODELS HDC3/HDC6



**Please read this manual completely before attempting to install, operate or service this equipment**

This document is prepared for trained Duke service technicians. It is not to be used by anyone not properly qualified to perform these procedures.

This Service Manual is not all encompassing. If you have not been trained on servicing this product, be sure to read the manual completely before attempting servicing. Be sure all necessary tools, test equipment, and skills are available. Those procedures for which you do not have the proper skills and test equipment must be performed only by a qualified Duke trained service technician.

---

*This manual is Copyright © 2011 Duke Manufacturing Company. All rights reserved.  
Reproduction without written permission is prohibited. Duke is a registered  
trademark of the Duke Manufacturing Company.*

## Duke Manufacturing Company

2305 N. Broadway  
St. Louis, MO 63102  
Phone: 314-231-1130  
Toll Free: 1-800-735-3853  
Fax: 314-231-5074  
[www.dukemfg.com](http://www.dukemfg.com)

## IMPORTANT WARNING AND SAFETY INFORMATION

### WARNING

READ THIS MANUAL THOROUGHLY BEFORE OPERATING, INSTALLING, OR PERFORMING MAINTENANCE ON THE EQUIPMENT.

### WARNING

FAILURE TO FOLLOW INSTRUCTIONS IN THIS MANUAL CAN CAUSE PROPERTY DAMAGE, INJURY OR DEATH.

### WARNING

DO NOT STORE OR USE GASOLINE OR OTHER FLAMMABLE VAPORS OR LIQUIDS IN THE VICINITY OF THIS OR ANY OTHER APPLIANCE.

### WARNING

DO NOT OPERATE THIS EQUIPMENT WITHOUT PROPERLY PLACING AND SECURING ALL COVER AND ACCESS PANELS.

### CAUTION

Observe the following:

- Provide and maintain adequate minimum clearances from all walls and combustible materials.
- Provide and maintain adequate clearance for air openings.
- Keep the equipment area free and clear of combustible material.
- Operate equipment only on the type of electricity indicated on the specification plate.
- Retain this manual for future reference.

# TABLE OF CONTENTS

IMPORTANT SAFETY INSTRUCTIONS.....	2
INTRODUCTION.....	4
GENERAL.....	4
MODEL DESIGNATIONS.....	5
MAIN FEATURES.....	6
RELAY BOX.....	6
CONTROL DISPLAY.....	6
COMPONENT REPLACEMENT.....	7
TOOLS REQUIRED.....	7
CONTROL DISPLAY.....	7
CONTROL BOARD OR MYLAR COVER.....	7
RELAY BOX.....	8
Main Power On/Off Switch.....	8
Solid State Relays.....	9
24 Volt Step-Down Transformer.....	9
CHANNEL ASSEMBLY.....	10
TESTING AND TROUBLESHOOTING.....	11
COMPONENT TESTING.....	11
Primary Power Check.....	11
Fault Conditions.....	11
24 Volt Step-Down Transformer.....	12
Heater Element and Hi-Limit Thermostat.....	12
RTD.....	13
SEQUENCE OF OPERATION.....	14
TROUBLESHOOTING CHART.....	15
WIRING DIAGRAM.....	16

# INTRODUCTION

## GENERAL

The Duke HDC3 Dry Channel unit maintains the factory set point temperature on 3 channels (front, back, and center). The Duke HDC6 Dry Channel unit maintains the factory set point temperature on 6 channels. Each channel has an A and B zone. The Main Power On/Off Switch is located on the Relay/Control Box (herein after referred to as Relay Box). A display panel will cycle through the temperature of each channel followed by fault messages if a fault is detected.

The display temperature will be the average of the two zones.

**Figure 2. Channels and Zones**

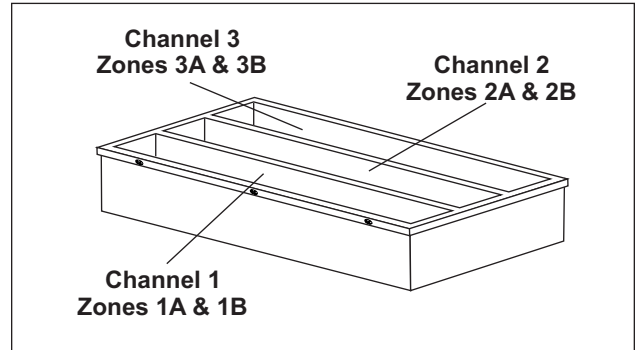

Pressing the ON button on the Control Display activates the display. Pressing the up arrow will cycle through the six temperature zones, displaying the actual temperatures. Pressing the down arrow will cycle through the set point temperature for each channel. The factory set point temperature is 275°F. The HEAT ON LED will indicate an activated relay in any zone. The READY LED is activated when all zones reach the set point temperature. A fault message will be displayed to indicate any zone that does not reach the set point temperature within 45 minutes of power up.

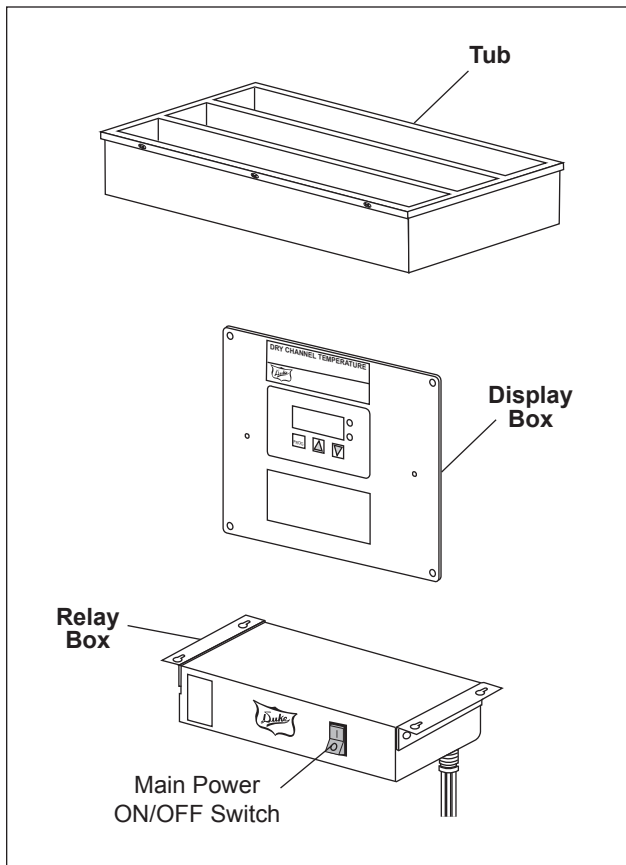

**Figure 1. Dry Channel Major Components**

**Figure 3. Control Display**

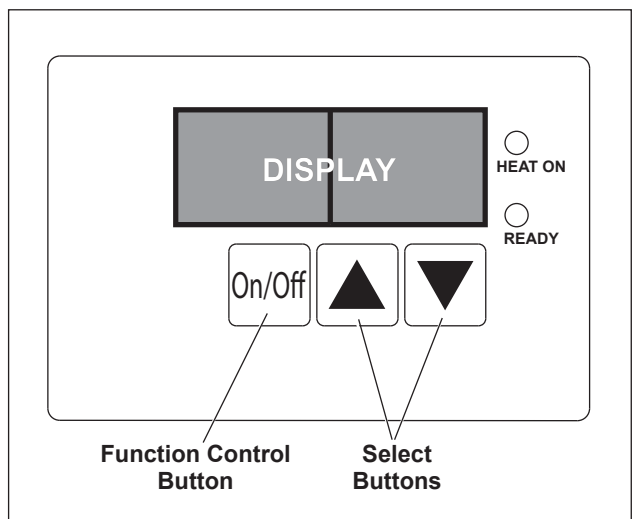

**MODEL DESIGNATIONS**

The following chart lists the different model designations and provides information on the weight and electrical requirements.

**TABLE 1. MODEL SPECIFICATIONS**

<b>MODEL NO.</b>	<b>SHIPPING WT.</b>	<b>ELECTRICAL SPECIFICATIONS</b>
HDC3-37.5-208	160 lbs (59.7 kg)	208VAC, 10.1A, 2100W, 50/60Hz
HDC-37.5-240	160 lbs (59.7 kg)	240VAC 8.8A, 2100W, 50/60Hz
HDC6-37.5-208	315 lbs (117.6 kg)	208VAC, 20.1A, 4200W, 50/60Hz
HDC6-37.5-240	315 lbs (117.6 kg)	240VAC, 17.5A, 4200W, 50/60Hz



## MAIN FEATURES

### RELAY BOX

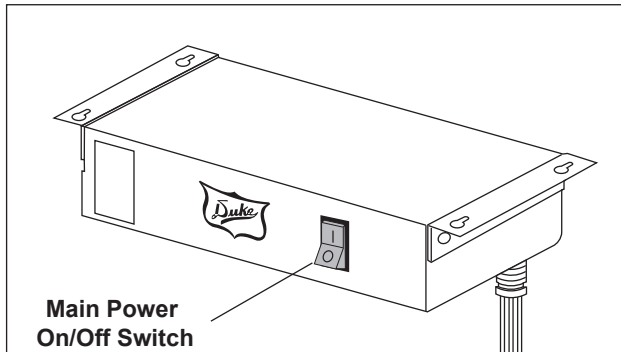

**Figure 4. Relay Box**

The Main Power On/Off Switch is located on the lower right side of the Relay Box. This is a lighted double pull single throw (DPST) switch rated at 20 Amperes. The Relay Box houses a 24 Volt Step-Down Transformer and six Solid State Relays (SSR).

### CONTROL DISPLAY

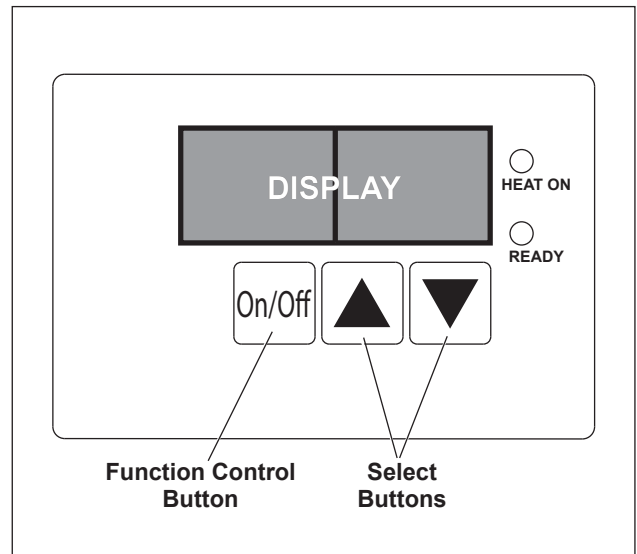

**Figure 5. Control Display**

The display provides a readout of actual temperature, set point temperature and fault conditions.

The control board inside the Control Display maintains the temperature of all three channels.

Each channel has an A & B zone. The control board monitors each zone's temperature and activates a relay to supply power to the heater for that zone. When the ON/OFF button is pressed, the display cycles through the temperature of each channel. If a fault is detected, the fault code is displayed. The displayed temperature will be the average of the two zones associated with that channel.

## COMPONENT REPLACEMENT



### WARNING:

**BEFORE ANY REPLACEMENT PROCEDURE BEGINS, THE HDC3/ HDC6 MUST BE ISOLATED FROM THE POWER SOURCE TO PREVENT POSSIBLE ELECTRICAL SHOCK.**

### TOOLS REQUIRED

The only tools required are normal hand-tools.

### CONTROL DISPLAY

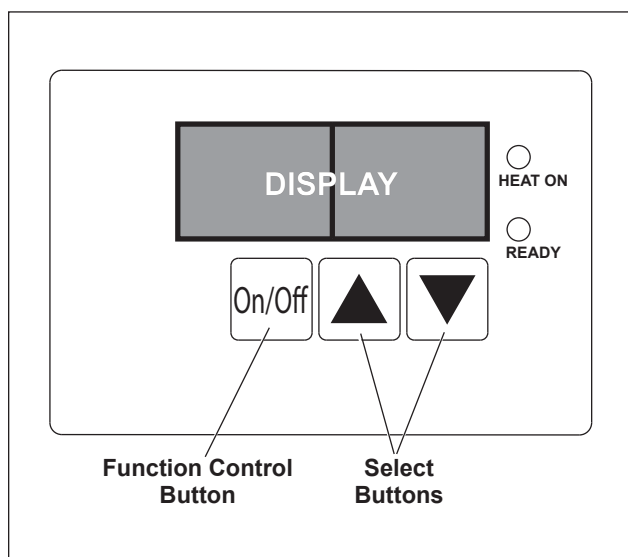

**Figure 6.** Control Display

The location of the Control Display will vary by application and cabinet choice. It is mounted from the front and is held in place by four screws.

1. Place the Main Power On/Off Switch in the off position.
2. Disconnect the Dry Channel unit from its power source. Use proper Lockout/Tagout procedures.
3. Remove the four screws securing the Control Display and move it away from mounting surface.

4. If the Control Display is to be completely removed, tag and disconnect the wires.
5. Remove Control Display.
6. Reverse the procedure to install Control Display.

**NOTE:** The following Control Display component removal is based on the Control Display having already been removed from its mounting surface.



### WARNING:

**BEFORE ANY REPLACEMENT PROCEDURE BEGINS, THE HDC3/ HDC6 MUST BE ISOLATED FROM THE POWER SOURCE TO PREVENT POSSIBLE ELECTRICAL SHOCK.**

### CONTROL BOARD OR MYLAR COVER

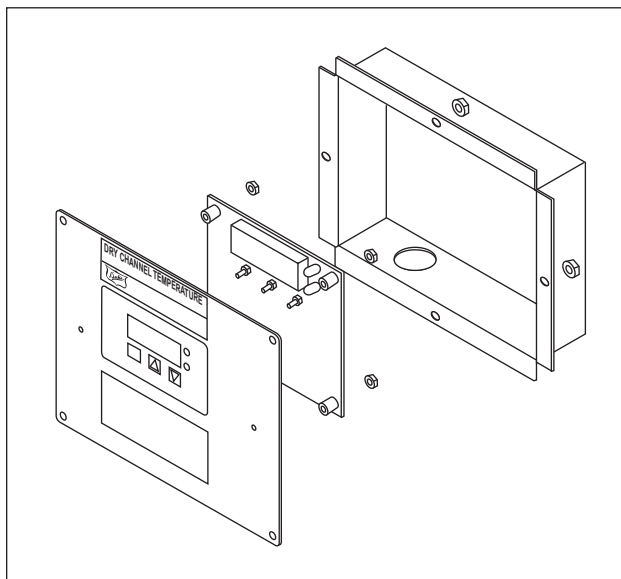

**Figure 7.** Exploded View of Control Display

1. With the Control Display removed from its mounting surface, tag and disconnect wires.
2. Remove the four cover retaining nuts.

3. Remove the Control Board nuts from the four studs.
4. Reverse the procedure to install a new Control Board or Mylar Cover.

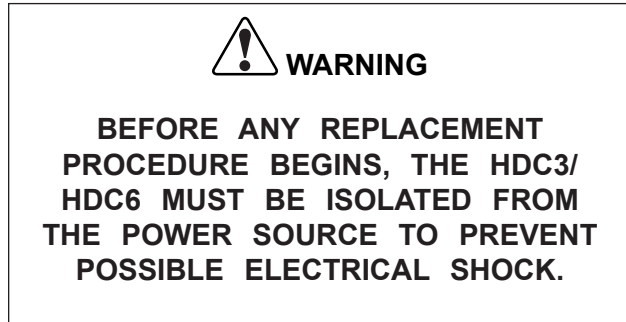

**RELAY BOX**

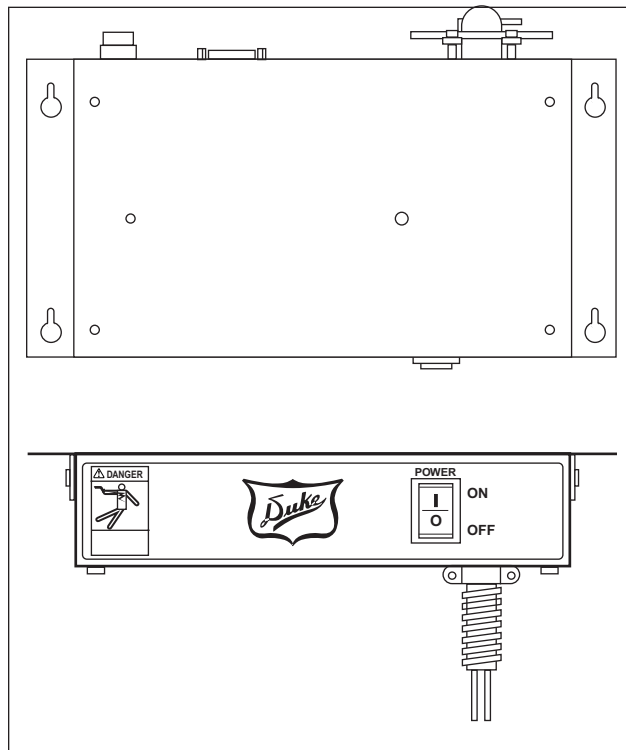
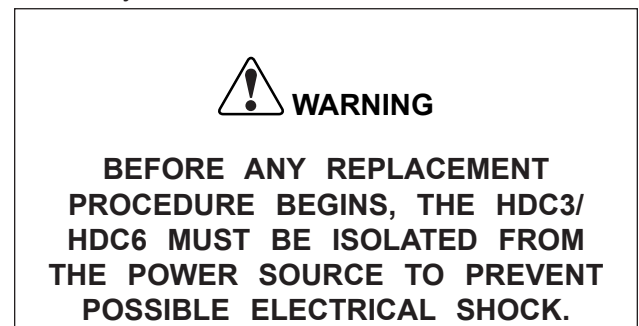

**Figure 8. Relay Box**

Typically the Relay Box is mounted on the bottom of the Dry Channel Tub on the right side. The actual location may vary based on installation application or cabinet configuration used.

1. Place the Main Power On/Off Switch in the off position.

2. Remove the Dry Channel unit from its power source. Use proper Lockout/Tagout procedures.
3. Remove the four screws securing the Relay Box to its mounting surface.
4. If complete Relay Box is to be replaced, tag and disconnect wires.
5. Remove Relay Box.
6. Reverse procedure to assemble and install Relay Box.



**NOTE:** The following Relay Box component removal and replacement assumes the Relay Box has already been removed from the Dry Channel unit.

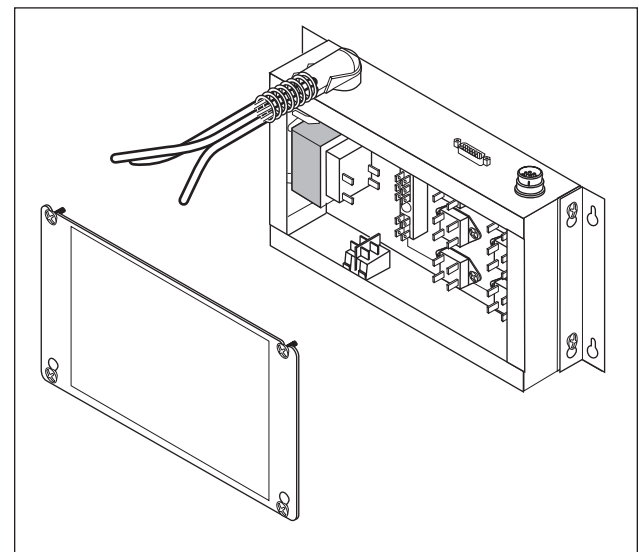

**Figure 9. Exploded View of Relay Box**



### Main Power On/Off Switch

1. Remove the four screws securing the Relay Box cover. Set the cover aside for reuse.
2. Tag and disconnect the Main Power On/Off Switch wires.
3. Squeeze the Main Power On/Off Switch retaining springs and push the switch out through the front of the box.
4. Reverse this procedure to install a new Main Power On/Off Switch.



**WARNING**

**BEFORE ANY REPLACEMENT PROCEDURE BEGINS, THE HDC3/ HDC6 MUST BE ISOLATED FROM THE POWER SOURCE TO PREVENT**

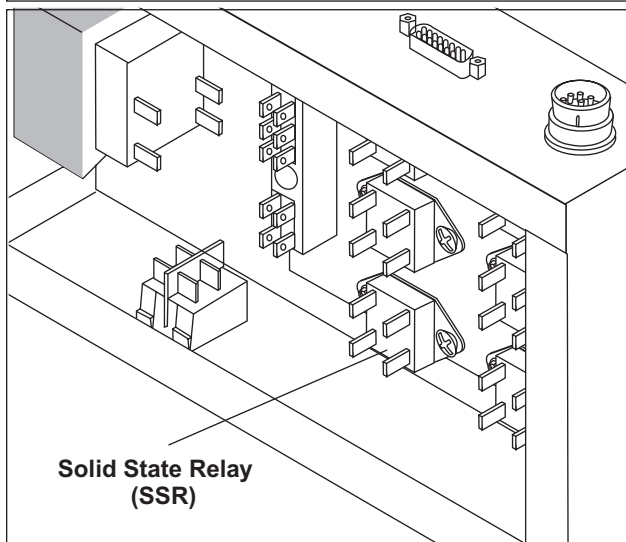

**POSSIBLE ELECTRICAL SHOCK.**

### Solid State Relays (SSR)

**Figure 10.** *View of SSR*

1. Using a Multimeter, determine which SSR has failed.
2. Tag and disconnect the wires from the faulty SSR.

3. Remove the two screws that attach the SSR to the board and remove the faulty SSR.

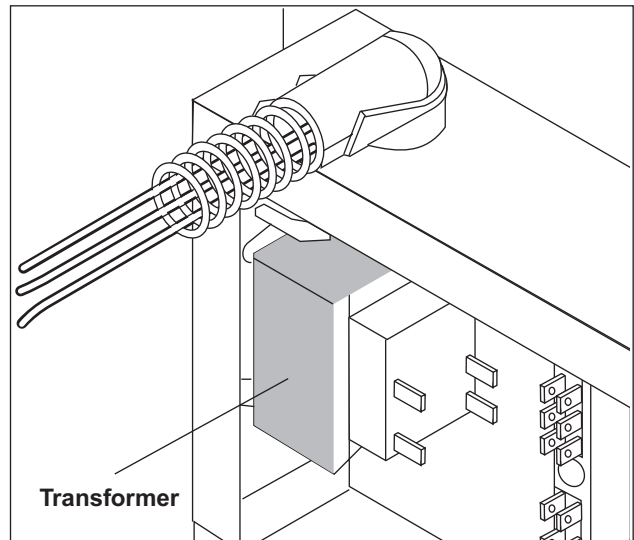

4. Reverse procedure to install a new SSR.

### 24 Volt Step-Down Transformer

**Figure 11.** *Step-Down Transformer 208/240V Primary, 24V Secondary*



**WARNING**

**BEFORE ANY REPLACEMENT PROCEDURE BEGINS, THE HDC3/ HDC6 MUST BE ISOLATED FROM THE POWER SOURCE TO PREVENT POSSIBLE ELECTRICAL SHOCK.**

1. Using a multimeter test the 24 Volt Step-Down Transformer to determine whether or not it is the reason for the failure.
2. Tag and disconnect wires from Transformer.
3. Remove four nuts attaching Transformer to studs on the relay box body and remove Transformer.
4. Reverse this procedure to install a new 24 Volt Step-Down Transformer.

## CHANNEL ASSEMBLY

A heating zone consists of a Heater Element, Hi-Limit Thermostat and an RTD. These components are embedded in a foil wrap that is attached to the bottom of each Channel Assembly. The foil wrap is not serviceable in the field. The entire Channel Assembly must be replaced in the event of a failure.

1. Set the Main Power On/Off Switch to the Off position.
2. Disconnect the Dry Channel unit from its power source. Use proper Lockout/Tagout procedures.
3. Remove six screws (three on each side) attaching the channel top frame to the tub.

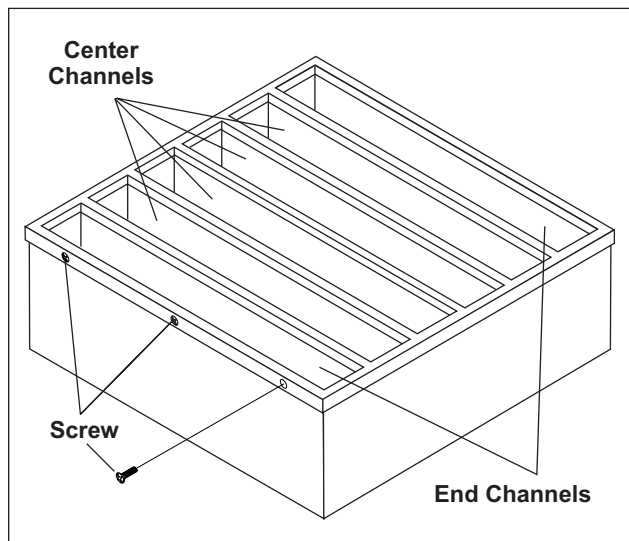

**Figure 12.** *HDC6 Channel Configuration*

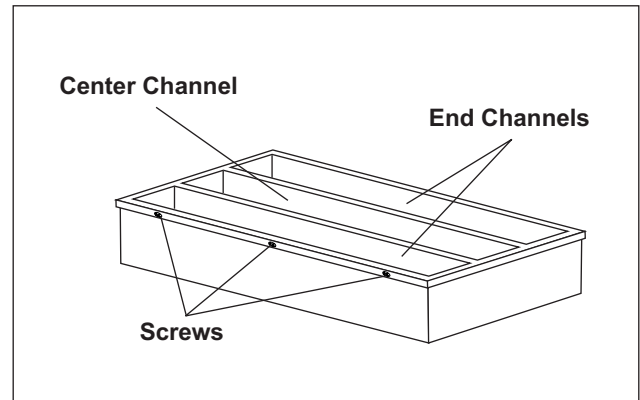

**Figure 13.** *HDC3 Channel Configuration*

4. Carefully lift the Channel Assembly out, taking care not to damage wire connections.
5. Tag and disconnect the wires from the foil wrap on the Channel Assembly to the Control Board.
6. Reverse this procedure to install a new Dry Channel Assembly.

**NOTE:** The End Channels are a different assembly from the Center Channels. Install the appropriate channel assembly in its position in the tub.

7. Return the Dry Channel unit to service and check for proper operation.

## TESTING AND TROUBLESHOOTING

### COMPONENT TESTING

Most component testing can be performed using a Digital Multimeter.

**NOTE:** When a continuity test is being performed, the HDC3/HDC6 must be isolated from the power source to prevent damage to the test equipment.

### Primary Power Check

**CAUTION:** Input voltage source must match voltage indicated on dataplate. Voltage should be 208 or 240 VAC depending upon the application.



1. Check the input voltage source for correct measurement of 208 or 240 VAC. If input voltage is not present, check for open circuit breakers or fuses supplying the input power.
2. Measure the voltage across the input terminals on the Main Power On/Off Switch. Voltage should be the same as input voltage source. If voltage is not present, check power source and power cord.
3. Set the Main Power On/Off Switch to on and check for source voltage across the switch output terminals. If voltage is not present replace switch.
4. Measure voltage across primary of 24 Volt Step-Down Transformer. If voltage is not present, check wiring. If input voltage is present, the primary power check is complete.

### Fault Conditions

Fault conditions are indicated on the Control Display.

1. **High Temperature Fault** – For a High Temperature Fault the display will show “HIX”, where X indicates the channel (“F” for front, “C” for center, and “b” for back). A buzzer will sound for one second every 30 seconds. The operator can cancel this alarm by pressing any button on the Control Panel. The alarm will reactivate after 20 minutes if the problem has not been rectified. Both relays for the channel will be turned off while the fault exists.
2. **Low Temperature Fault** – For a Low Temperature Fault the display will show “LOX”, where X indicates the channel (“F” for front, “C” for center, and “B” for back). A buzzer will sound for one second every 30 seconds. The operator can cancel this alarm by pressing any button on the Control Panel. The alarm will reactivate after 20 minutes if the problem has not been rectified.
3. **Probe Open/Short** – For a Probe Open/ Short Fault the display will show “PRX”, where X indicates the channel (“F” for front, “C” for center and “B” for back). The operator can cancel this alarm by pressing any button on the Control Panel. The alarm will reactivate after 20 minutes if the problem has not been rectified. The relays for both zones of the channel with a probe fault will be turned off while the fault exists. The control will display 000°F for the temperature of the channel with the fault condition.

### 24 Volt Step-Down Transformer

The 24 Volt Step-Down Transformer (Transformer) is located in the Relay Box.



**WARNING**

**USE EXTREME CARE WHEN PERFORMING THIS TEST. MEASUREMENTS ARE PERFORMED ON CIRCUITS WITH VOLTAGE APPLIED.**

1. Set the Main Power On/Off Switch to the off position.
2. Remove Relay Box cover.

**CAUTION:** Ensure that primary of Transformer is correctly connected for input voltage source.



3. Set voltmeter to AC and select a range to measure the 208/240 VAC input voltage level.
4. Attach voltmeter across Transformer primary terminals.
5. Set the Main Power On/Off Switch to on. Measure voltage across the Transformer primary. Voltage should be the same as the input voltage source. If no voltage is present, check wiring to Transformer.

6. If correct voltage is present at primary, measure the secondary voltage.
7. If the secondary voltage is near 24 VAC, Transformer is operating properly. If voltage is low or 0 VAC, disconnect wire from Transformer secondary and recheck secondary voltage. If voltage is still near 0 VAC, replace Transformer.
8. If voltage is now near 24 VAC, a short exists somewhere else in the circuit. Further trouble isolation testing is required.

### Heater Element and Hi-Limit Thermostat

Check the Heater Element and Hi-Limit Thermostat by measuring the resistance of the Heater Element. To access the Heater Element, follow the procedure described in the CHANNELASSEMBLY paragraph in the COMPONENT REPLACEMENT section.

1. Remove the suspect Channel Assembly from the Dry Channel Tub.
2. Disconnect the wires to the Channel Assembly to be tested.
3. Connect an ohmmeter across the heater leads and verify that the resistance is approximately 124Ω between one end of the Heater Element and the Hi-Limit Thermostat. The resistance across both heat elements should be approximately 248Ω
4. Replace Dry Channel Assembly if the Foil Wraps tests open.

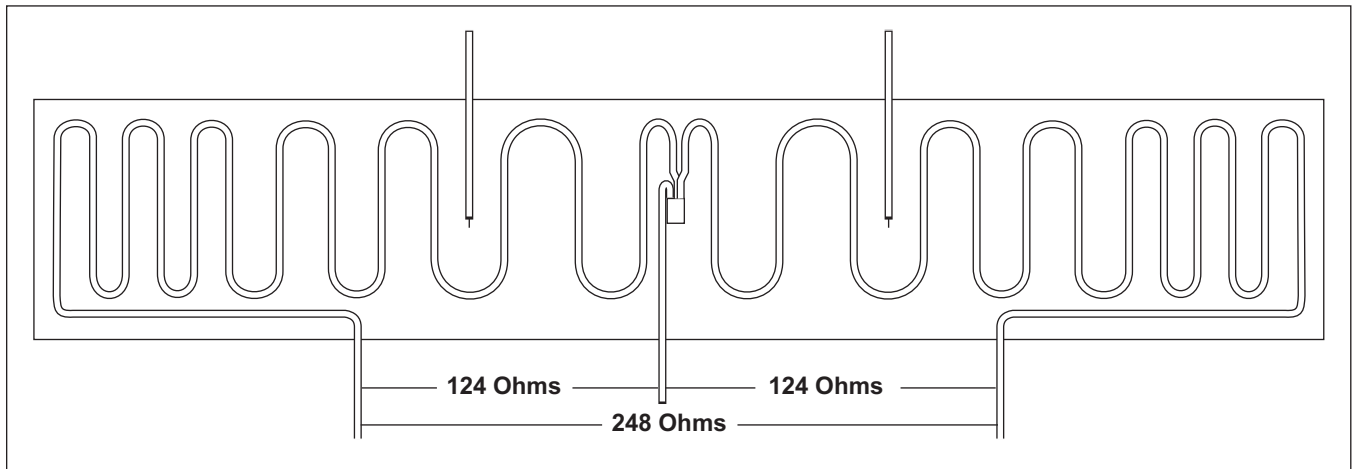

**Figure 14. Foil Wrap Heater Configuration**

**RTD**

Check the RTD Thermocouple by measuring the resistance between the two lead wires. There are two RTD probes in each Foil Wrap. To access the RTD, follow the procedure described in the CHANNEL ASSEMBLY paragraph in COMPONENT REPLACEMENT section.

1. Disconnect the RTD wires.

2. Connect an ohmmeter across the RTD leads and verify that the resistance is approximately  $1000\Omega$  at ambient room temperature.
3. Check both RTDs in the Channel Assembly.
4. Replace the Dry Channel Assembly if an RTD is defective.

Refer to the Wiring Diagram.

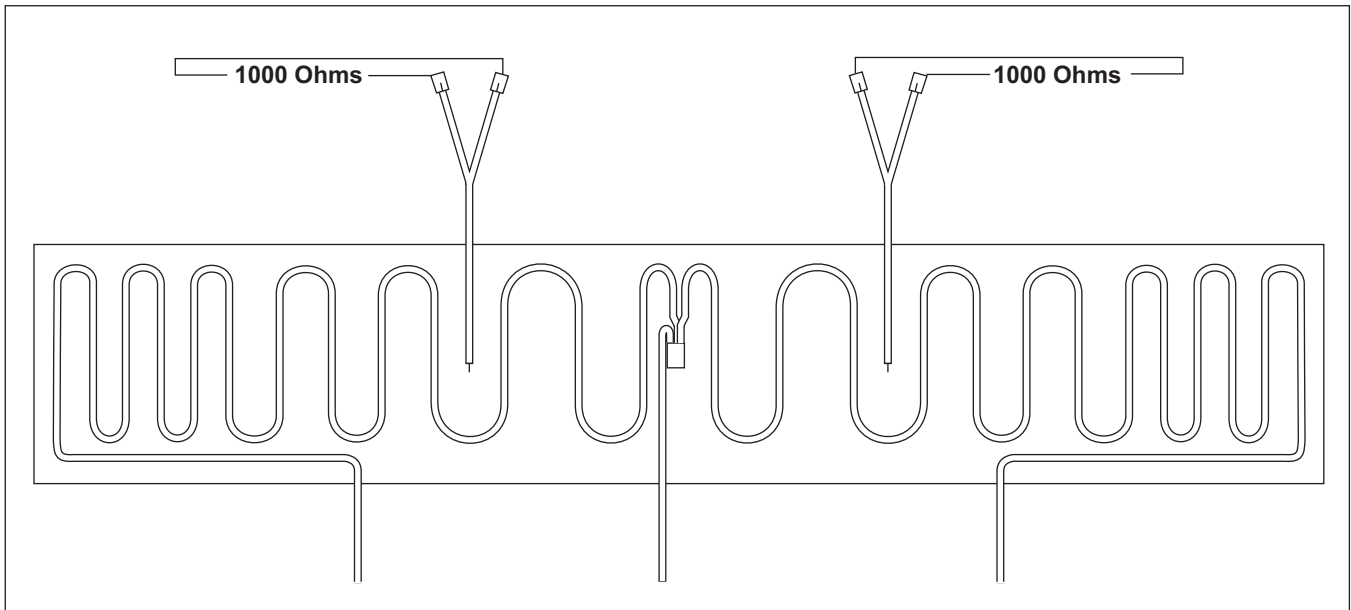

**Figure 15.** Foil Wrap with RTD Connectors

## SEQUENCE OF OPERATION

1. Plug HDC3/HDC6 unit into the proper line source per the dataplate on the unit.
2. Set the Main Power On/Off Switch to on.
3. Line voltage is applied through the Main Power On/Off Switch to the following:
  - a. To the primary of the 24 Volt Step-Down Transformer.
  - b. Through a junction box to one side of each of the six Hi-Limit Thermostats.
  - c. Through each element and to one side of each respective SSR.
4. The secondary of the Transformer provides 24 VAC to the Control Display, allowing the Control Board to power on.
5. The Control Board provides a reference set point temperature and monitors the channel heat level through the RTD's. If the channel temperature is less than the set point temperature for a given channel, the SSR for that channel is activated.
6. Voltage is routed through the SSR to the other side of each Heater Element causing the Heater Element to operate through the normally closed Hi-Limit Thermostat and begin raising the temperature of the channel.
7. When the heat reaches the set point temperature (normally set at 275°F), the SSR for that channel is turned off disconnecting the Heater Element.
8. If the SSR does not shut off and the temperature continues to rise, the Hi-Limit Thermostat opens at 375°F cutting off power to the Heater Element. At the same time the Control Board provides a "High Temp Fault" indication to the display and turns off both SSRs to the faulty channel. An alarm is sounded every 30 seconds. The operator can cancel this alarm by pressing any button on the Control Panel. If the fault has not been corrected, the alarm will reactivate in 20 minutes.
9. The temperatures measured by the RTD's, are routed to the Control Display. Each zone's temperature within the channel will be displayed when the up button is pressed.
10. The set point temperature for each channel can be displayed by pressing the down button.

## TROUBLESHOOTING

SYMPTOM	CAUSE	REMEDY
Heating Elements do not heat.	Unit not plugged in	Plug unit in to proper power outlet.
	Main Power On/Off Switch not in on position	Move the Main Power On/Off Switch to on position.
	Faulty Control Board	Replace Control Board.
One Heating Element does not heat.	Defective Heating Element or Hi-Limit Thermostat	Check resistance across Heating Element and Hi-Limit Thermostat. It should be around 124Ω. Replace Channel Assembly if test fails.
	Defective RTD	Check resistance across RTD at ambient room temperature. Resistance should be approximately 1000Ω. Replace Channel Assembly if test fails.
	Defective SSR	Replace SSR.
	Defective Control Board	Replace Control Board.
Heating Elements operating but no indication on the Display Box.	Defective Display Board	Replace the Display Board.



# WIRING DIAGRAM

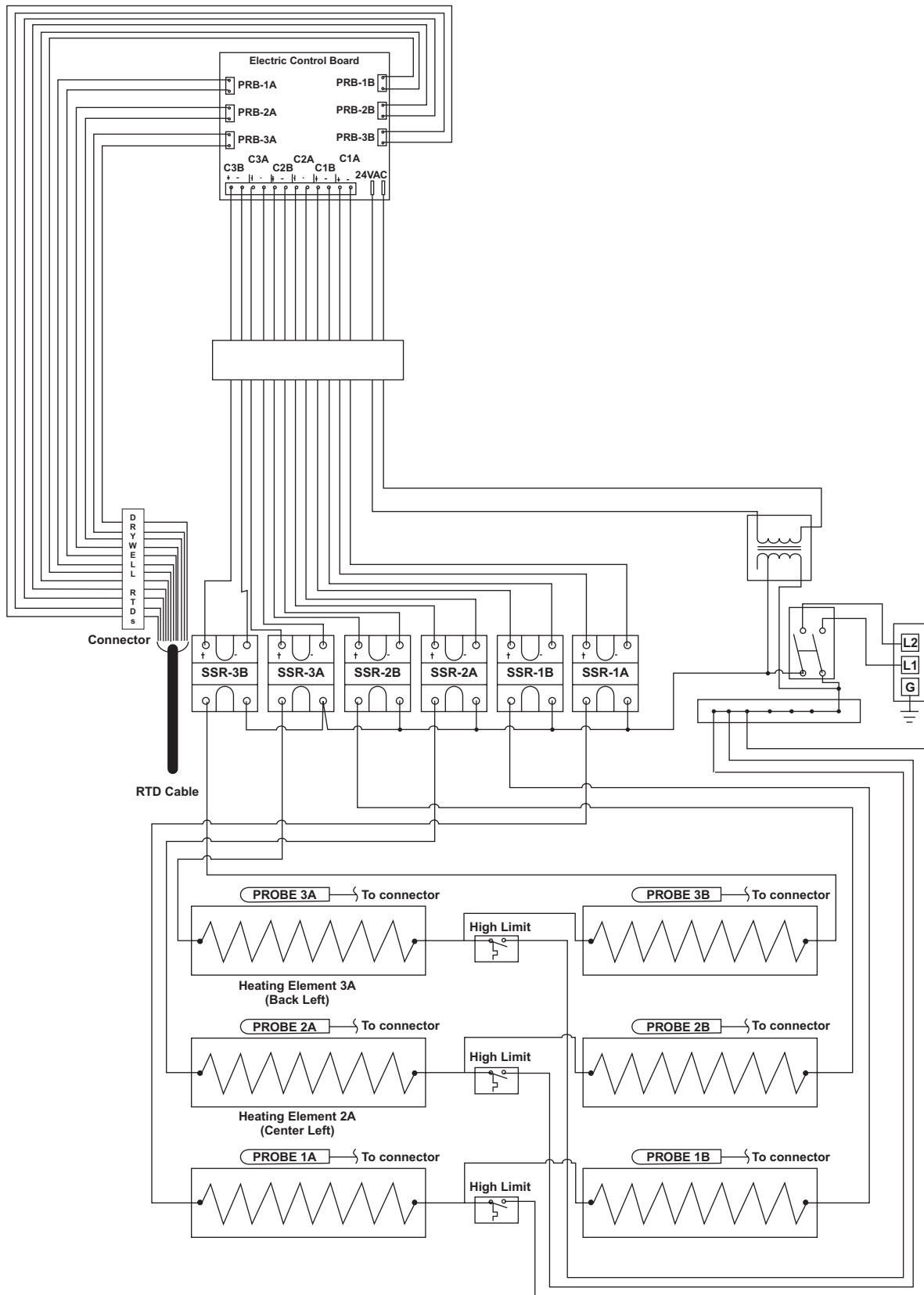





**NOTES:**



**NOTES:**



**NOTES:**



## **Duke Manufacturing Company**

**2305 N. Broadway  
St. Louis, MO 63102  
Phone: 314-231-1130  
Toll Free: 1-800-735-3853  
Fax: 314-231-5074  
[www.dukemfg.com](http://www.dukemfg.com)**