

# ALLEN & HEATH



## **WARNING – HIGH VOLTAGES**

Power Supply Unit (PSU) work should only be carried out by qualified personnel.

We recommend that you use an approved Allen & Heath service centre for all power supply work.

Please contact your local Allen & Heath distributor for more details.

<http://www.allen-heath.com/>

**ALLEN  
&  
HEATH**

**WZ20:8:2**

**20 INPUT 8 TRACK RECORDING CONSOLE**

**SERVICE  
MANUAL**

**PUBLICATION AP2933**

# INTRODUCTION

The information presented in this manual is intended for competent technical personnel to carry out service and product support for the *MixWizard WZ 20:8:2*. We assume that the reader is familiar with the related electronic theory and audio terminology, and is able to carry out basic servicing, fault-finding and repair of audio equipment of this type. Service personnel should also be familiar with audio systems, mains earthing and power requirements, as well as handling precautions.

For further information on the operation and application of the *MixWizard WZ 20:8:2* please refer to the **USER GUIDE** publication AP2932 supplied with each console.

Whilst we believe the information in this manual to be reliable we do not assume responsibility for inaccuracies. We also reserve the right to make changes in the interest of further product development.

# SERVICE AND TECHNICAL SUPPORT

Under normal conditions the *MixWizard WZ 20:8:2* does not require user maintenance or internal calibration. Any service work required should be carried out by qualified technical personnel only.

We are able to offer further product support through our worldwide distribution network. To help us provide the most efficient service please would you quote the console serial number in any communication regarding this product.

## SAFETY WARNING !

Mains electricity is dangerous and can kill. Mains voltage is present within the unit. Do not remove any covers with mains connected. Do not carry out any work within the unit while it is powered. High voltage components are insulated for safety but should not be touched with power applied. The mains voltage setting is indicated on the on the rear panel next to the mains socket. Check that this matches your local mains supply. Check your mains wiring and earthing before switching on.

### DO NOT REMOVE THE MAINS EARTH CONNECTION!

**The chassis is always connected to mains earth.** Audio 0V connects to the chassis internally. Should problems be encountered with ground loops operate the audio ground lift switches on other equipment connected to the unit or disconnect the cable screens at one end. Refer to the section on 'EARTHING' in the User Guide.

# CONTENTS

INTRODUCTION, SERVICE AND TECHNICAL SUPPORT .....	2
TECHNICAL DESCRIPTION .....	3
SPECIFICATION & CONNECTIONS .....	4
DIMENSIONS FOR FLIGHTCASING, INSTALLING THE CONSOLE .....	5
REMOVING THE CONNECTOR CIRCUIT BOARD .....	6-7
REMOVING A MONO or STEREO INPUT, LEFT or RIGHT CIRCUIT BOARD .....	8-9
INTERNAL LINK OPTIONS .....	10-11
ORDERING A CONSOLE, SPARE PARTS & ASSEMBLIES .....	12-14
FRONT & REAR PANELS .....	15
TRANSFORMER & POWER WIRING .....	16-17
MONO INPUT CIRCUIT BOARD COMPONENT IDENT .....	AG2894
MONO INPUT CIRCUIT DIAGRAM .....	C2894
STEREO INPUT CIRCUIT BOARD COMPONENT IDENT .....	AG2937
STEREO INPUT CIRCUIT DIAGRAM .....	C2937
LEFT CIRCUIT BOARD COMPONENT IDENT .....	AG2938
LEFT CIRCUIT BOARD CIRCUIT DIAGRAM sheet 1 .....	C2938
LEFT CIRCUIT BOARD CIRCUIT DIAGRAM sheet 2 .....	C2938
RIGHT CIRCUIT BOARD COMPONENT IDENT .....	AG2939
RIGHT CIRCUIT BOARD CIRCUIT DIAGRAM sheet 1 .....	C2939
RIGHT CIRCUIT BOARD CIRCUIT DIAGRAM sheet 2 .....	C2939
CONNECTOR CIRCUIT BOARD COMPONENT IDENT .....	AG2940A
CONNECTOR CIRCUIT BOARD CIRCUIT DIAGRAM sheet 1 .....	C2940A
CONNECTOR CIRCUIT BOARD CIRCUIT DIAGRAM sheet 2 .....	C2940A
CONNECTOR CIRCUIT BOARD CIRCUIT DIAGRAM sheet 3 .....	C2940A
CONNECTOR CIRCUIT DAUGHTER BOARD COMPONENT IDENT .....	AG2940B
CONNECTOR CIRCUIT DAUGHTER BOARD CIRCUIT DIAGRAM .....	C2940B
BLOCK DIAGRAM .....	34

# TECHNICAL DESCRIPTION

The ALLEN & HEATH *MixWizard WZ 20:8:2* is a dedicated 8-track rack mount or desk standing mixer with 8 mono inputs and 6 stereo inputs. All mono input channels have a 4 band 2-sweep EQ with 6 individual aux sends and Direct output. The 6 stereo inputs have a 2 band EQ with 2 stereo cue/aux sends and 2 mono aux sends. The 8 tape return inputs have individual level and pan controls with a stereo cue facility. In addition the *MixWizard WZ 20:8:2* also has extensive talkback facilities and an internal 1kHz sinewave oscillator for level checking. The internal power supply unit is located in the rotating connector module.

## CONSTRUCTION

---

All metal chassis for 19" rack mount in 10U space. Comprises a 16swg steel front panel housing individual channel circuit assemblies interconnected by means of soldered copper wire busbars. The connectors are housed in a rotating connector module for either rack or desk mounted applications. Access to the channel internal assemblies is by removal of the 18swg folded steel base. Access to the connectors and power supply components is by removal of the rear cover of the connector module without the need to remove the console base. The channel assemblies may be removed for servicing.

## THE CIRCUIT COMPONENTS

---

The *MixWizard WZ 20:8:2* is manufactured using high performance industry standard linear op-amp and discrete semiconductor circuit devices. In particular the switches and potentiometers have proven to be durable and problem free. When operated correctly the normal performance of the unit introduces no noticeable audio signal degradation.

## AUDIO INPUTS AND OUTPUTS

---

All XLR connector inputs and outputs are balanced (differential) with high impedance inputs and low impedance outputs. To use these with unbalanced equipment the -ve signal should be linked to 0V in the cable or input connector. All unbalanced connections are line level 3-pole TRS ¼" jack sockets. All outputs are low impedance and thus capable of driving several high impedance inputs simultaneously. All inputs and outputs are in phase.

## THE PFL SYSTEM

---

The console PFL switches send pre-fade signals to the PFL mix bus. These signals are switched with 4053 CMOS gates located on the RIGHT circuit board (PCB No: AG2939). The supply for the 4053 is  $\pm 8V$  DC and is derived locally from the  $\pm 16V$ . The gates are switched when a PFL switch is selected.

## EARTHING THE AUDIO SYSTEM

---

The console chassis is connected to mains earth via the mains power cable. Console audio 0V is also connected to chassis.

**FOR SAFETY REASONS NEVER REMOVE THE EARTH WIRE FROM THE MAINS PLUG.**

Multiple earth paths cause earth (ground) loops which may result in audible hum and interference. These may be avoided by making sure that there is only one path to earth from each piece of equipment, disconnecting audio cable screens at one end if necessary.

## INTERCONNECTIONS

---

Where possible use balanced connections for the CHANNEL inputs, AUX/CUE SENDS, and both L/R outputs to minimise noise pick-up. Avoid running audio cables near to mains or lighting cables, thyristor dimmer units or power supplies etc. These may cause audible hum and buzz. The use of low impedance sources significantly reduces interference pick-up. Check the cables for correct wiring to avoid problems with phase reversal and unreliable connection. The *MixWizard WZ 20:8:2* follows the convention for XLR pin 2 and jack tip = signal hot (+).

**ALWAYS USE BALANCED CABLES WHEN CONNECTING TO PHANTOM POWERED MICROPHONES.**

**WHEN USING NON-PHANTOM POWERED OR UNBALANCED MICROPHONES OR UNBALANCED LINE SOURCES, MAKE SURE THAT THE +48V IS DISABLED TO PREVENT ACCIDENTAL DAMAGE.**

**INDIVIDUAL CHANNELS CAN HAVE +48V DISABLED, REFER TO THE LINK OPTIONS SECTION IN THE USER GUIDE OR SERVICE MANUAL.**

If ground loops cause problems, connect the cable screen at one end only. Balanced outputs may be connected to unbalanced inputs and vice versa by linking the signal cold (-) to 0V ground.



# DIMENSIONS

The diagrams below give the dimensions for flightcasing the console.

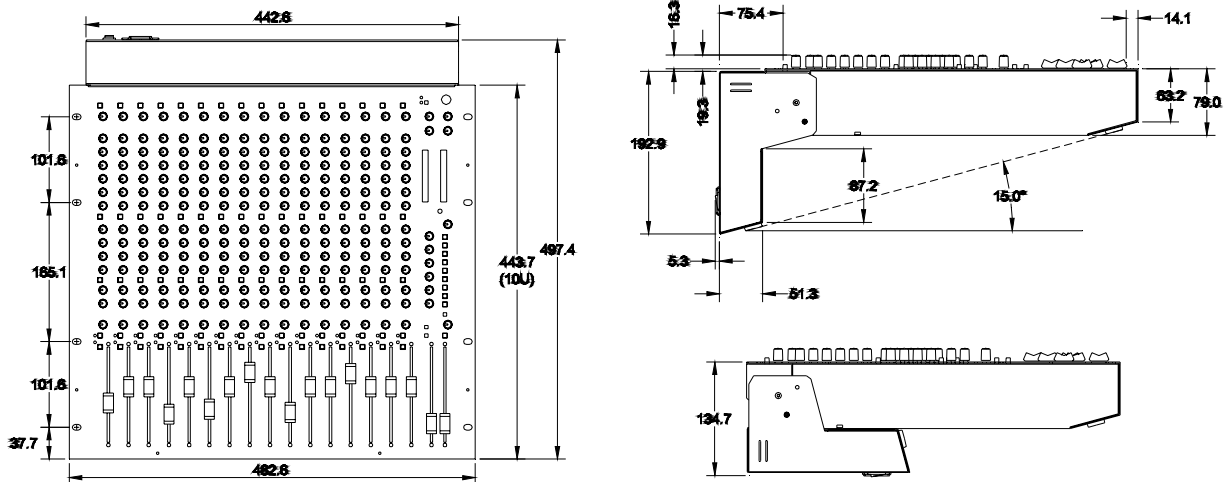

## INSTALLING THE CONSOLE

The *MixWizard Series* features the ALLEN & HEATH Quick Change Connector (QCC) system. The rear connector module may be hinged and locked into either of two positions: **Rear connectors** for desktop operation with the control panel sloped at a convenient 15 degrees, or **Underside connectors** for 19" rack mounting in a compact 10U space. The connector position can be easily changed at any time to fit your application.

To change the position remove the crosshead locking screw on each side, swing the connector pod into position, and refit the two screws.

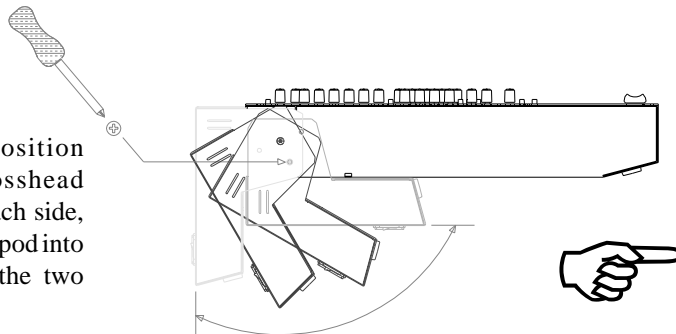

**Do not transport or carry the console with the locking screws removed.**

**Do not attempt to remove the connector pod from the console.**

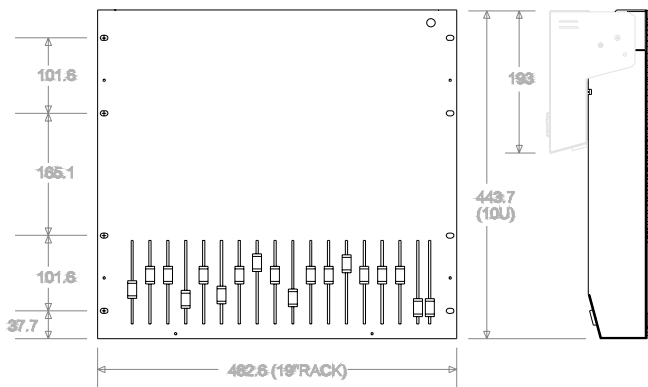

### 19" Rack Mounting

Mount the console in the rack using 4x M6 bolts each side for maximum strength. We recommend you fit the bolts with plastic cup washers to protect the panel, and they look good... These should be available from the supplier of the rack unit or a good hardware store.

### Desktop Operation

The console is fitted with rubber feet to ensure it does not slip or scratch the work surface. The control panel is angled at 15 degrees for operating convenience.

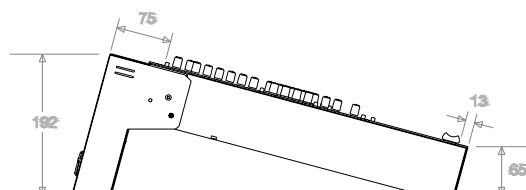

## REMOVING THE CONNECTOR CIRCUIT BOARD ASSEMBLY

Before beginning any service work, remove all power to the unit and disconnect any signal cables where necessary. The rotating connector module must be set for desk top operation to gain access to the cover screws. It is not necessary to disconnect the connector module from the main unit. Service work is best carried out with the unit inverted on a clean work surface suitably covered to protect the mixer cosmetics. Ensure adequate lighting and use the correct tools. Access to the connector circuit board options can be achieved without the complete removal of the circuit board.

- 1.) Working from the rear of the console remove screws (A) fixing the XLR connectors to the panel and using a 12mm Nutdriver, remove jack nuts (B). Also remove the 2 screws indicated.

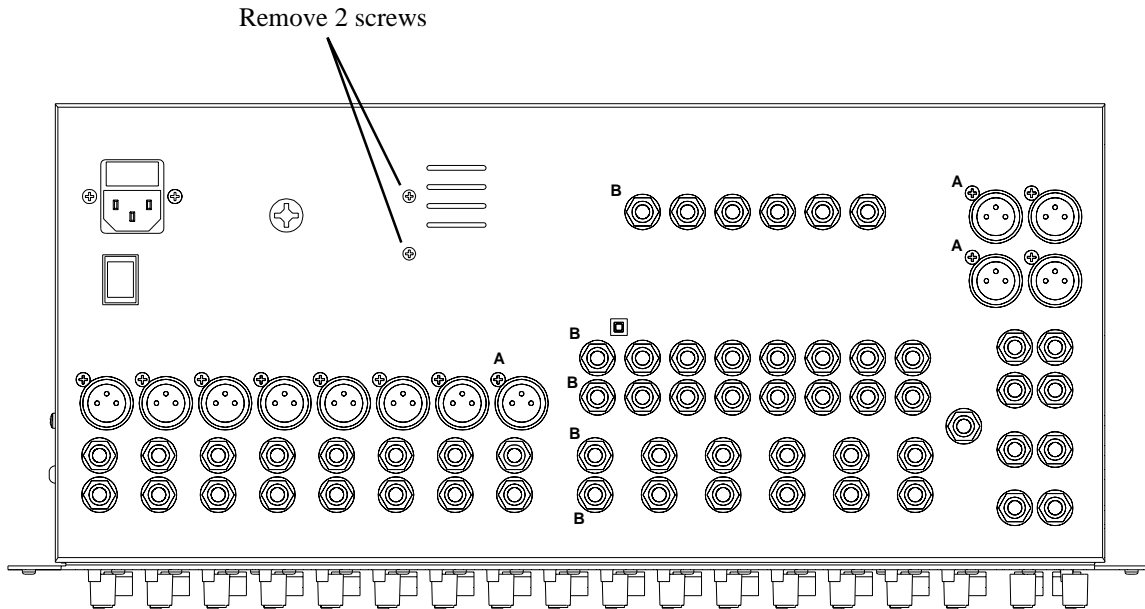

- 2.) With the unit inverted, remove the 4 connector cover screws (C) and remove the cover.

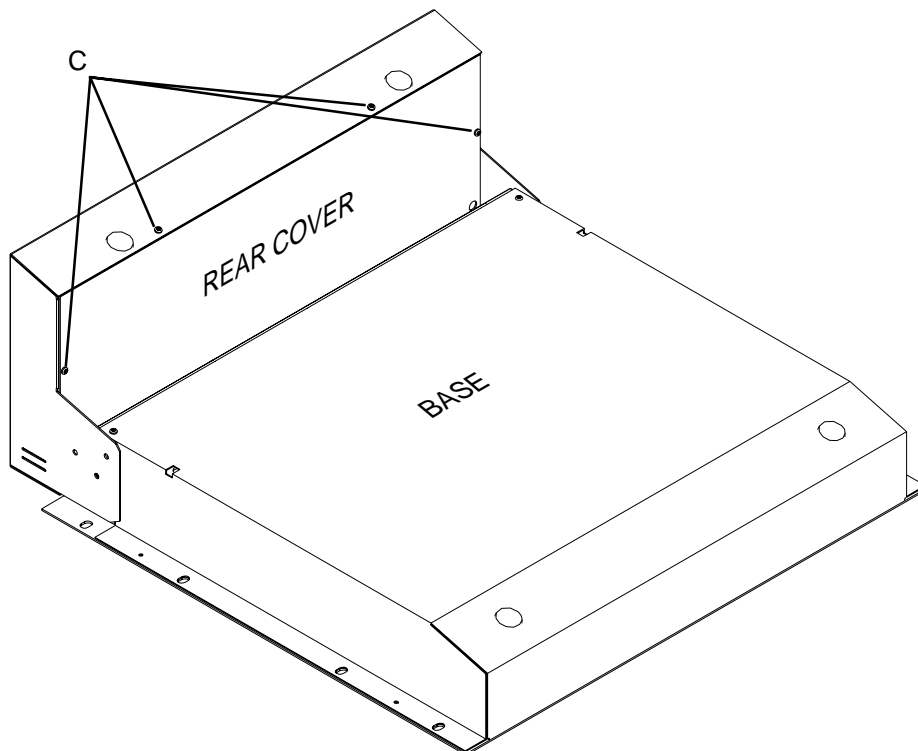

Access to the connector circuit board options can be achieved at this stage by carefully easing the circuit board assembly from the rear panel with the harnesses still connected. It is not necessary to completely remove the circuit board assembly to change the options. Refer to the section INTERNAL LINK OPTIONS for more details.

## To completely remove the connector circuit board assembly

- 4.) First remove the base cover of the main unit to gain more access. Refer to 2 and 3 in the section REMOVING AN INPUT, LEFT or RIGHT CIRCUIT BOARD for details on the removal of the base cover.
- 5.) Cut the cable ties along the bottom edge of the connector circuit board fixing the harness to the connector circuit board assembly and lift the circuit board assembly from the chassis.
- 6.) Then carefully disconnect the ribbon cable and the 4 flexible flat cables plugged into the circuit board assembly.
- 7.) Before desoldering the wires connected to the circuit board, make a note of their colour and locations.
- 8.) The circuit board can now be completely removed from the chassis.

When all service work is complete, remove all debris such as solder, component legs and wire clippings from inside the console and check your work carefully before reassembly. To refit the connector circuit assembly follow the above procedure in reverse order. Make sure all harnesses are correctly aligned and plugged on. Test for correct operation.

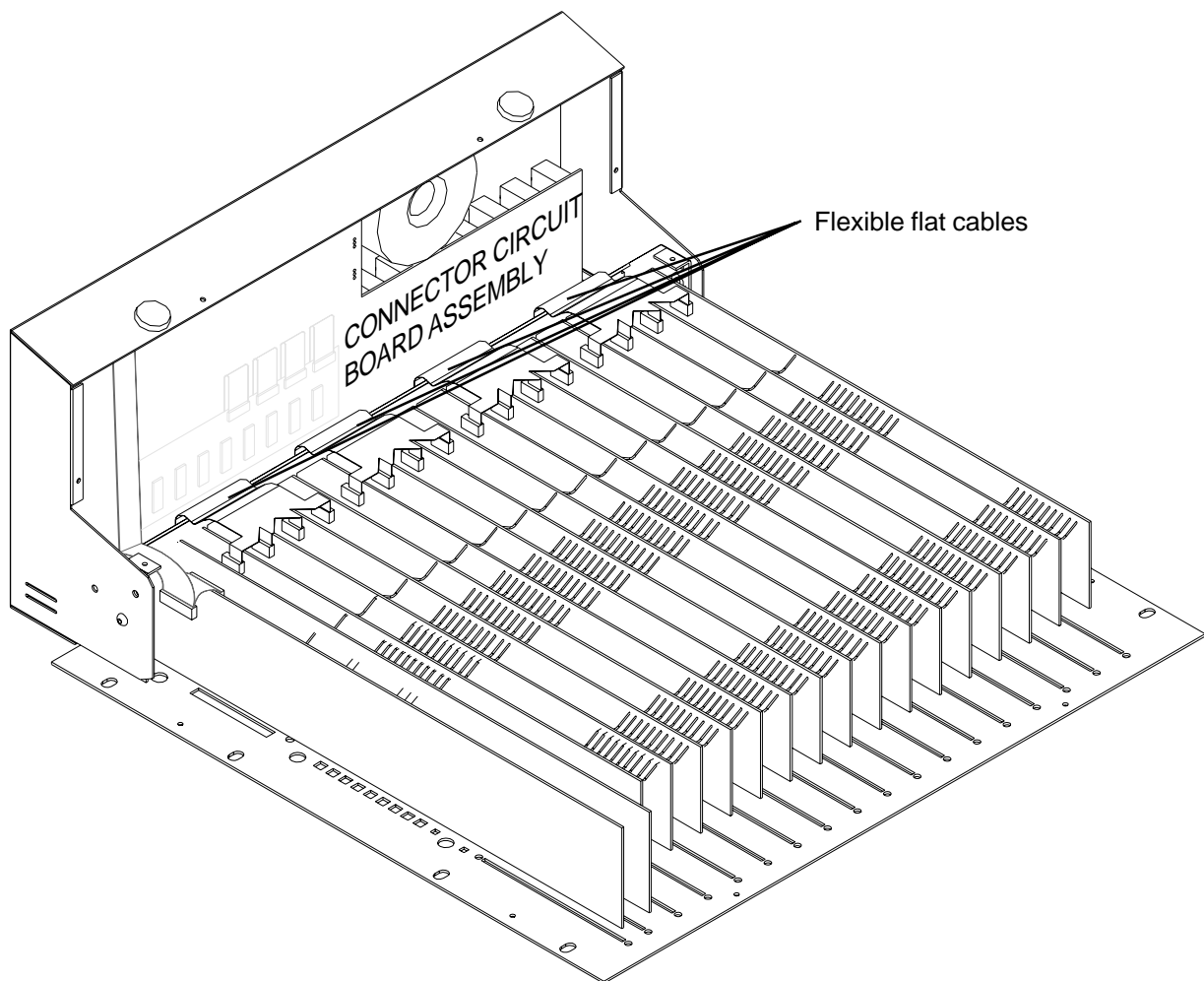

Unit inverted with the base and connector cover removed.



## REMOVING AN INPUT, LEFT or RIGHT CIRCUIT BOARD ASSEMBLY

Before beginning any service work, remove all power to the unit and disconnect any signal cables where necessary. The rotating connector module must be set for desk top operation to gain access to the cover. Service work is best carried out with the unit inverted on a clean work surface suitably covered to protect the mixer cosmetics. Ensure adequate lighting and use the correct tools. Access to the channel circuit board options can be achieved without the removal of the circuit board.

- 1.) If completely removing a circuit board assembly, pull off the knobs and remove the pot nuts and fader screws from the circuit assembly to be removed. The switch caps can remain in place. If removing the LEFT circuit board assembly remove the nut on the headphone socket.
- 2.) Working from the front of the mixer remove screws and nuts (A) fixing the base cover to the front panel.

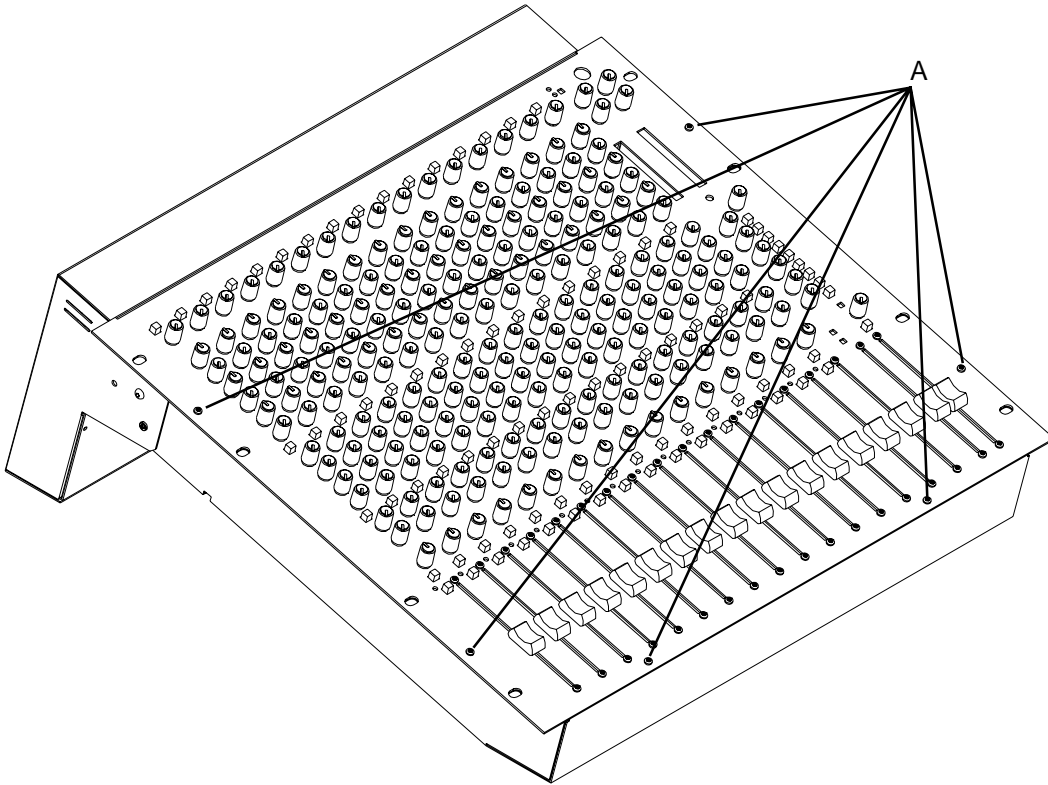

- 3.) With the unit inverted, remove the 2 remaining screws (B) in the base cover and remove the base.

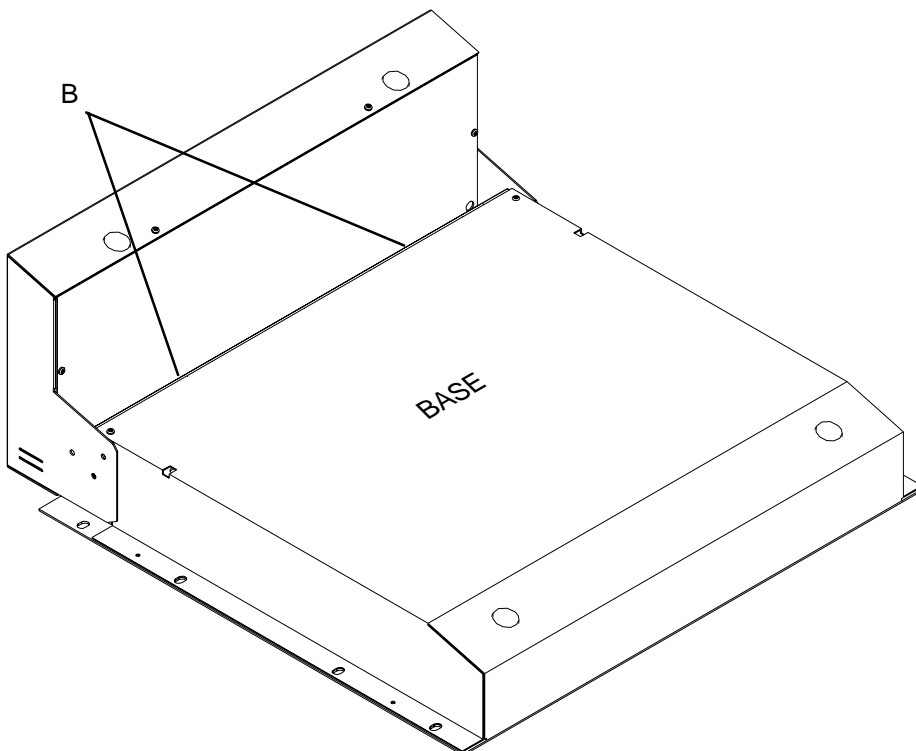

Access to the input channel circuit board options can be achieved at this stage by carefully cutting and resoldering the link options as necessary. It is not necessary to completely remove the circuit board assembly to change the options. Refer to the section INTERNAL LINK OPTIONS for more details.

### To completely remove a circuit board assembly

- 4.) Identify the circuit board assembly to be removed and then cut the buss wires half way between each circuit board. Disconnect the flexible flat cable (C) plugged into the connectors mounted along the edge of the circuit board. If removing the LEFT or RIGHT circuit board assembly, the ribbon cable (D) and flexible flat cable (E) will have to be carefully unplugged as well.
- 5.) The circuit board can now be removed.

When all service work is complete, remove all debris such as solder, component legs and wire clippings from inside the console and check your work carefully before reassembly. To refit the circuit assembly follow the above procedure in reverse order. Make sure all harnesses are correctly aligned and plugged on. Test for correct operation.

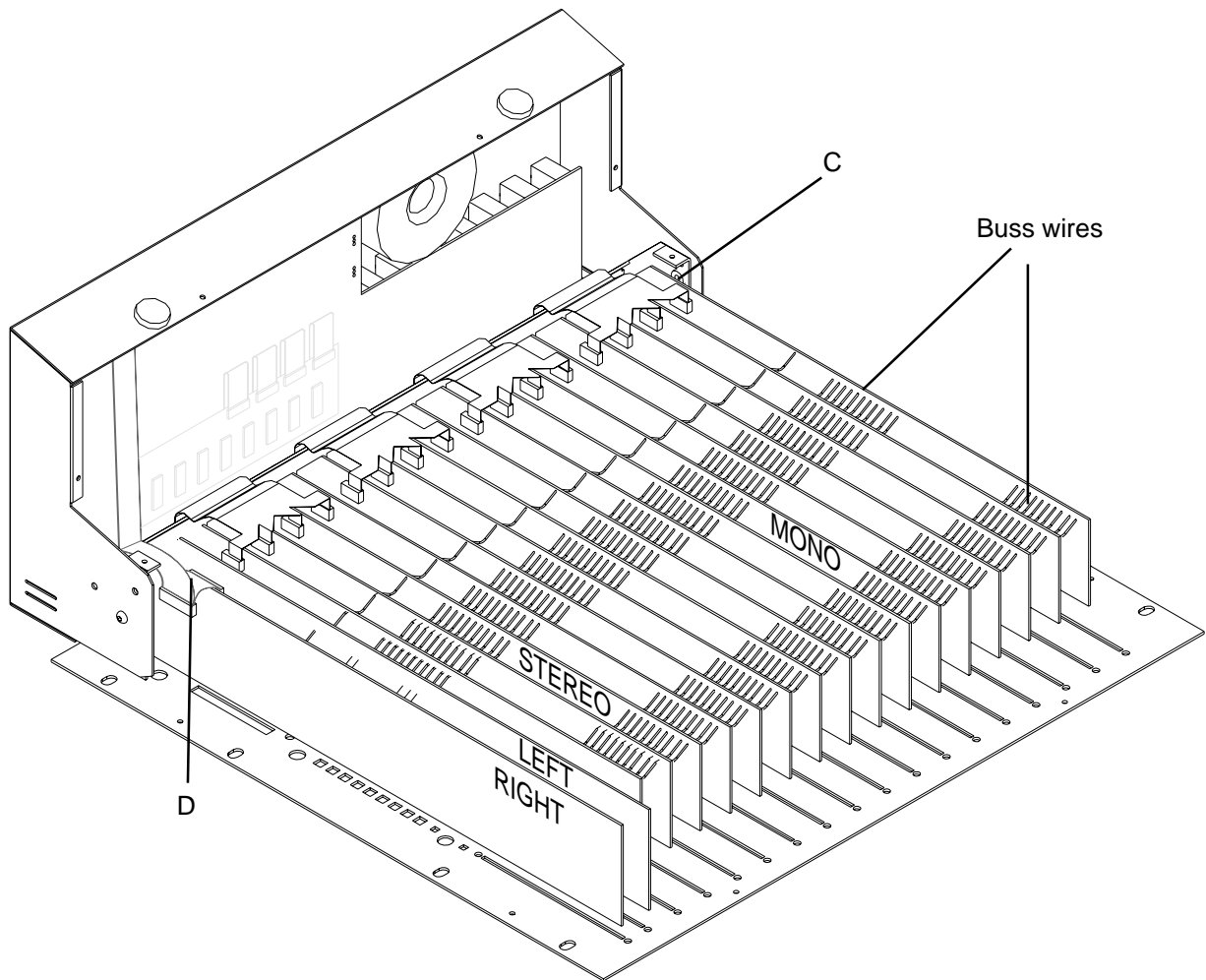

Unit inverted with the base and connector cover removed.

Cut each wire  
in the centre

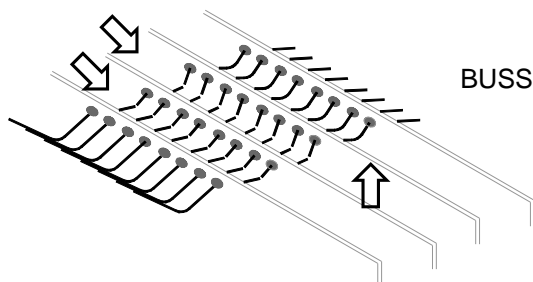

BUSS WIRES

Overlap  
and  
solder

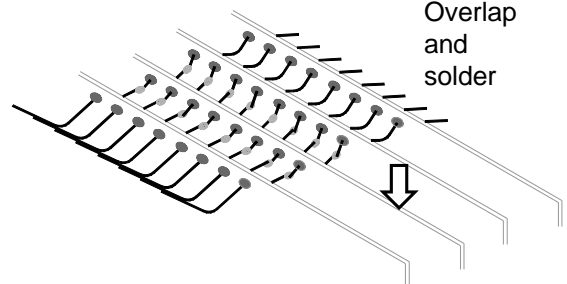

# INTERNAL LINK OPTIONS

The console is set to satisfy most applications that should be encountered. However, the following internal link options are offered to provide alternative settings for those applications that may require them. Access to the options requires the removal of the rear covers depending on which option settings are to be altered. Refer to the section for removing circuit board assembly on which the link option is located. Some options involve the cutting of circuit board tracks and soldering of circuit board links and should only be carried out by competent technical personnel. Further information is available from **ALLEN & HEATH** if required.

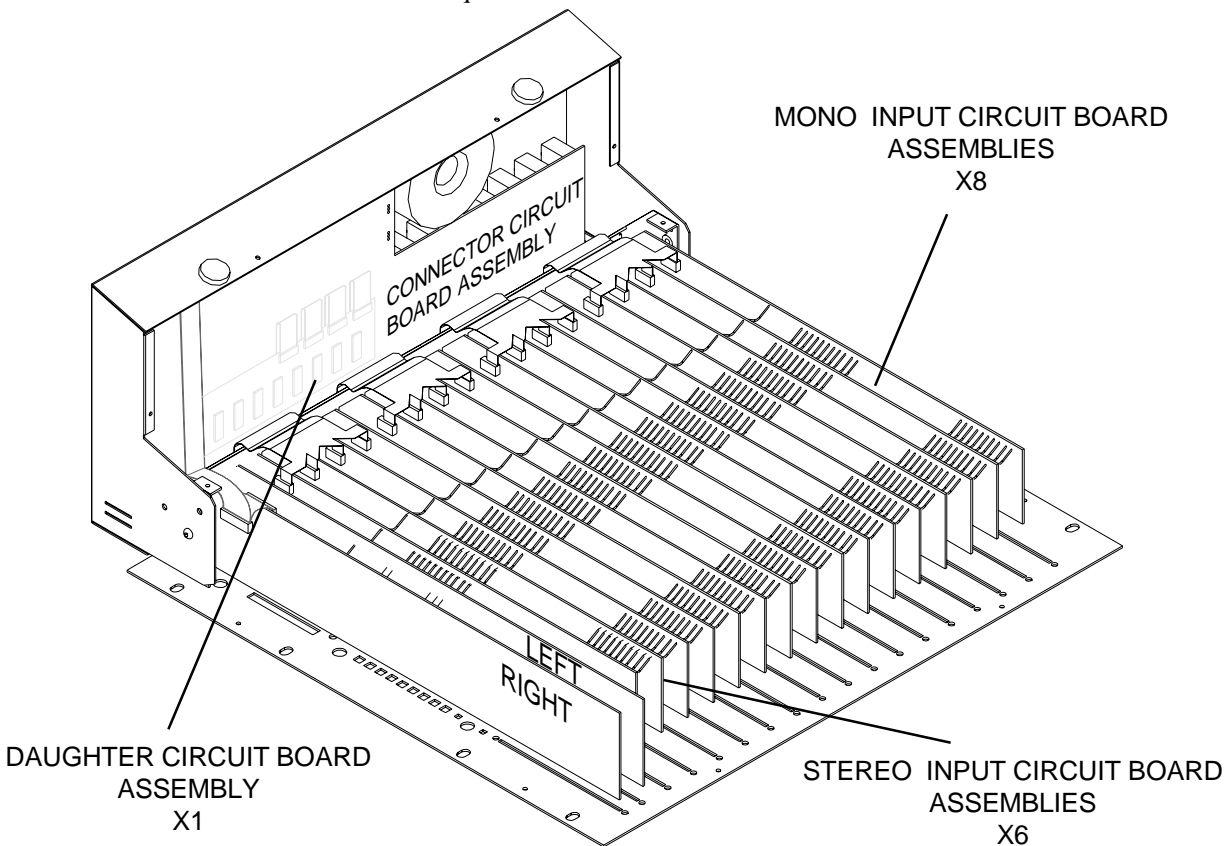

Unit inverted with the base and connector cover removed.

## Channel Pre-Fade Aux Send Options

The pre-fade sends are set post-EQ and post-ON as standard. However, link options on each channel assembly allow pre-EQ and/or pre-ON if required. Refer to the diagram below.

## Channel Direct Output Source

The direct outputs are sourced post-fader as standard. A link option is available per channel to select a pre-fade source. Refer to the diagram below.

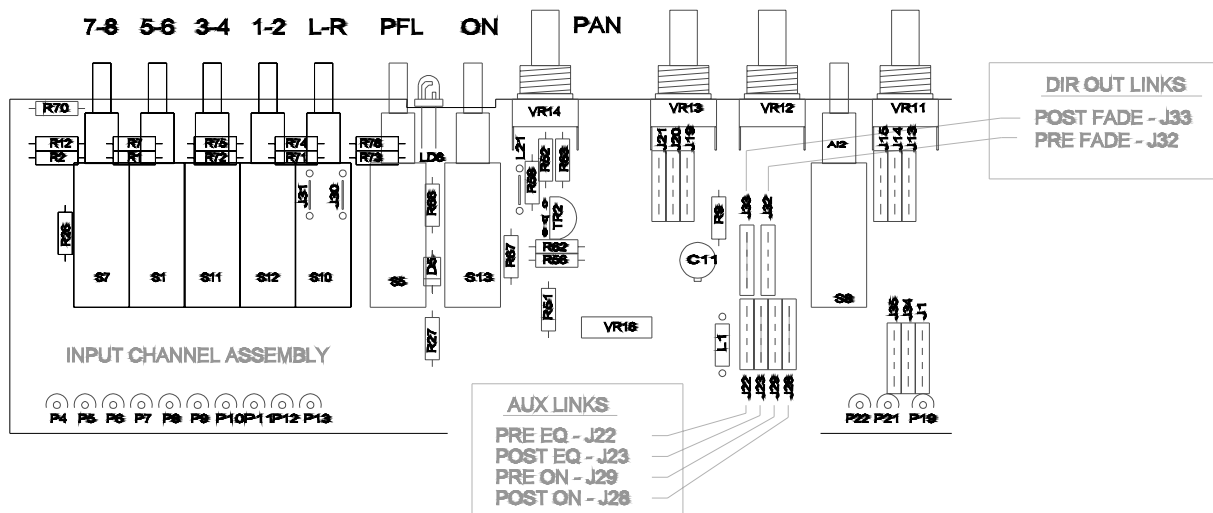

## Phantom Power Disable

It is perfectly safe to connect non-phantom powered sources such as dynamic microphones to powered XLR sockets providing that **balanced leads and sources are used**. The +48V supply is current limited through 6.8k ohm resistors to each XLR to prevent damage. However, you can disable phantom power to selected channels by cutting out links on the rear connector circuit assembly.

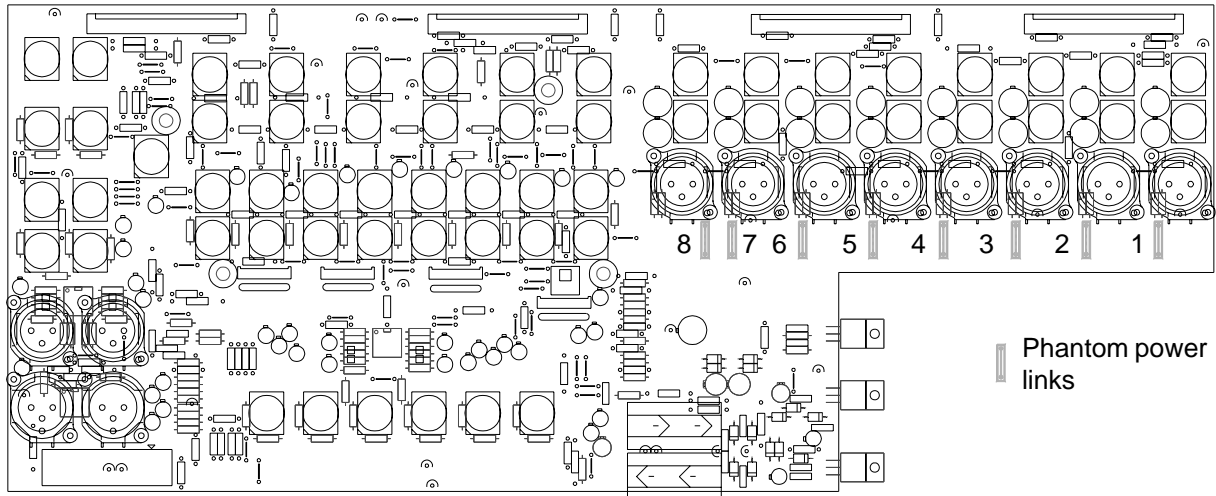

Connector circuit board assembly.  
component side view

## 2 Track 1 & 2 Track 2 Input Sensitivity

Both 2 track inputs can be set for nominal high level +4dBu operation or low level -10dBV operation as is common with much of the external equipment available today. The factory default setting for 2 track 1 is nominal high level +4dBu operation and for 2 track 2 the factory default setting is low level -10dBV operation. Most outboard equipment includes output level adjustment but if you wish to change the input sensitivity, the rear connector circuit board assembly can be reconfigured.

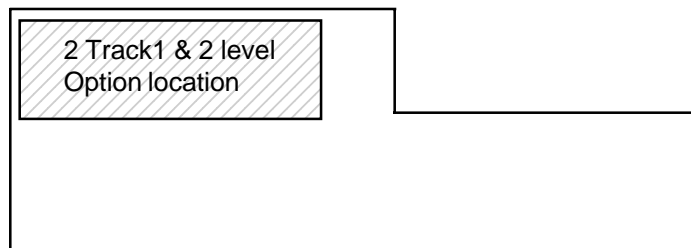

Connector circuit board assembly  
trackside view

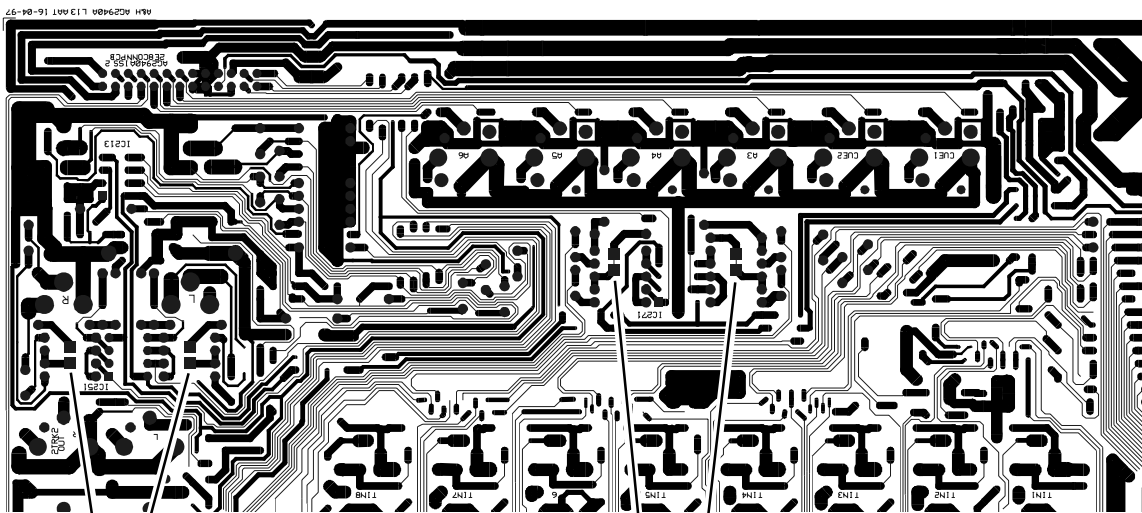

Solder link between square pads for -10dBV operating level on 2 Track 1.

Cut tracks between square pads for +4dBu operating level on 2 Track 2.

# ORDERING SPARE PARTS

## ORDERING A CONSOLE

To order a new console unit please specify the model number and AC mains voltage required.

MODEL	DESCRIPTION	ORDER CODE
<i>MixWizard 20:8:2</i>	8 Mono + 6 Stereo Input channels	WZ 2082/volts
<i>MixWizard 16:2</i>	16 Mono Input channels	WZ 1602/volts

## MANUALS AND SUPPORT DOCUMENTATION

DESCRIPTION	ORDER CODE
<i>MixWizard 20:8:2</i> User Guide	AP2932
<i>MixWizard 20:8:2</i> Service Manual	AP2933
<i>MixWizard 20:8:2</i> Brochure	AP2941

## SERVICE TOOLS

The tools required to service the *MixWizard* range of products are standard to an electronics service workshop and are easily obtainable. The following items are necessary for disassembly and service access:

1-point Crosshead screwdriver (M3, 4AB)	AT0004
2-point Crosshead screwdriver (M4, 6AB)	AT0002
11mm AF Nutdriver (potentiometer nuts, headphone socket nuts)	
12mm AF Nutdriver (jack nuts)	

## ORDERING AN ASSEMBLY

The following assemblies for the *MixWizard 20:8:2* are supplied fully tested. Please quote the description and order code for the part required.

Printed circuit (PCB) assemblies:

Mono Input PCB assembly	002-257
Stereo Input PCB assembly chans 13/14, 15/16	002-258
Stereo Input PCB assy chans 9/10, 11/12, 17/18, 19/20	002-270
Left PCB assembly	002-259
Right PCB assembly	002-260
Connector & Daughter PCB assembly	002-261

IDC connector harnesses:

<i>MixWizard WZ 20:8:2</i>	26 way Master harness	AL2978
----------------------------	-----------------------	--------

## ORDERING A SPARES KIT

It is recommended that the spares kit order code **002-247** is held and maintained by the service agent to enable in-field service repairs to the *MixWizard WZ 20:8:2* independent of the ALLEN & HEATH factory. Commonly available items such as resistors, capacitors, tools and soldering equipment are not included. The contents of the kit is listed below. Individual spare parts may be ordered. Please quote the description and order code for the part required.

DESCRIPTION	ORDER CODE	QTY
-------------	------------	-----

### Fixings:

Screw 4AB x 5/16" Pan Pozi Black	AB0057	10
Screw M2.5 x 4mm Pan Pozi Black	AB2944	10
Screw M3 x 4mm Pan Pozi Black	AB0233	10
Screw M3 x 8mm Pan Pozi Black	AB0073	5
Screw M3 x 6mm TT Pan Pozi Black	AB0071	5
Screw M3 x 10mm CSK Pozi Black	AB0093	5
Screw M3 x 10mm Pan Pozi Black	AB0076	5
Screw M3 x 12mm Pan Pozi Black	AB0078	5
Nylock Nut M3	AB0102	5

### Knobs and caps:

Knob Yellow & Grey 11mm D	AJ2079	10
Knob Dark Grey & Grey 11mm D	AJ2078	10
Knob Green & Grey 11mm D	AJ2077	10
Knob Blue & Grey 11mm D	AJ2075	10
Knob Brown & Grey 11mm D	AJ2080	10
Knob Red & Grey 11mm D	AJ2074	10
Knob L./blue & Grey 11mm D	AJ2076	10
Fader Knob 11mm White+Black line	AJ8078	10
Fader Knob 11mm Yellow+White line	AJ8080	5
Fader Knob 11mm Blue+Black line	AJ8081	5
Button 5.5mm Square Grey	AJ0363	10
Button 5.5mm Square Red	AJ0364	10
Button 5.5mm Square White	AJ0373	10

### Faders, Potentiometers, switches, and connectors:

10KD fader 100mm	AI8108	5
10KD x 2 fader 100mm	AI8116	5
20KK (203K)	AI8003	5
20KB (203B) centre click	AI8004	5
200KC x 2 (204C)	AI8005	5
20KB x 2 (203B 14mm wide)	AI8006	5
20KK x 2 (203K 14mm wide)	AI8007	5
10KAC x 2 (103KAC 14mm wide)	AI8008	5
5KD reverse (502RD)	AI8111	5
5KB (502B)	AI8112	5
Pot Nut 9mm	AB8050	10
Switch 2PCO Latching	AL0162	5
Jack Socket Vert PCB+nut (IN, INSERTS, ST1/2)	AL8082	10
Jack Socket Vertical PCB + nut	AL8114	10
Jack Socket Headphone	AL0328	1
XLR 3 Pin Female Vertical PCB Mount	AL2410	5
XLR 3 Pin Male Vertical PCB Mount	AL2411	5

### LEDs and Semiconductors:

LED 3mm T1 Yellow	AE0084	5
LED 3mm T1 Green	AE0085	5
LED 3mm T1 Red	AE0086	5
LED Bar Rectangular 8Green/3Yellow/1Red	AE2701	2
Transistor 2N4403 PNP	AE0273	5
Transistor BC214C PNP	AE0031	2
Transistor BC549 NPN	AE0020	2
IC TL072CP Dual Op Amp	AE0046	5
IC NE5532N OP-AMP	AE0221	1
IC LM339N Quad Comparator	AE0071	2
IC CMOS 4053B	AE0117	3
IC SSM2142P Balanced output driver	AE0302	-

## **POWER SUPPLY:**

Mains lead IEC-2pin EURO	AH0205	-
Mains lead IEC-3pin UK	AL0206	-
Mains lead IEC-3pin US (C33)	AL0323	-
Mains Fuse 20mm T315mA (UK,EU)	AL0349	5
Mains Fuse 20mm T630mA (USA,CAN)	AL0297	5
Transformer 30VA	AM0918	-
IC Adjustable Regulator 783 (+48V DC)	AE0214	2
IC Regulator 7815 (+15V DC)	AE0047	2
IC Regulator 7915 (-15V DC)	AE0048	2
Insulating kit TO220	AA0693	2

## **Miscellaneous:**

<b>MixWizard WZ 16:2</b> Packing assembly	002-245	-
<b>MixWizard WZ 20:8:2</b> Packing assembly	002-271	-
Flex cable 39 way 200mm	AH2900	2
Flex socket 39 way straight	AL2902	-
Flex socket 8 way 90deg	AL2901	-

# FRONT & REAR PANELS

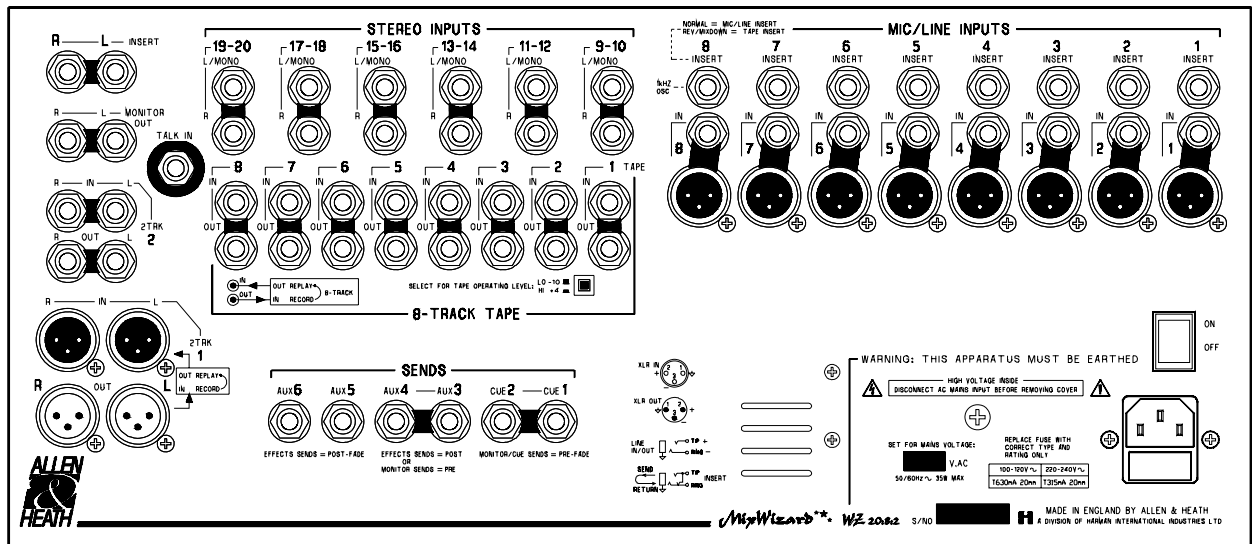
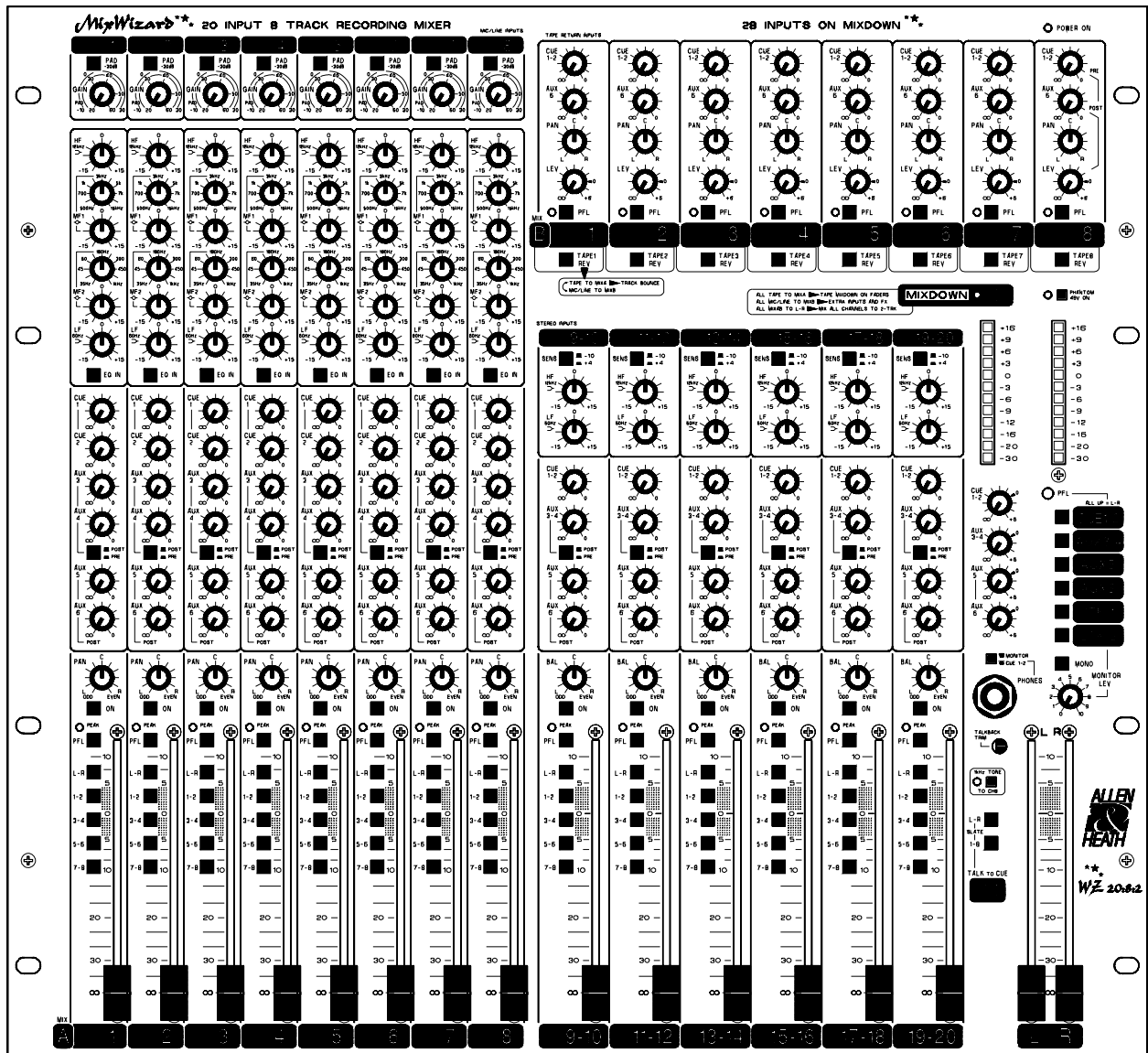



## 2e TRANSFORMER - MAINS WIRING

SLEEVED & UNCONNECTED.

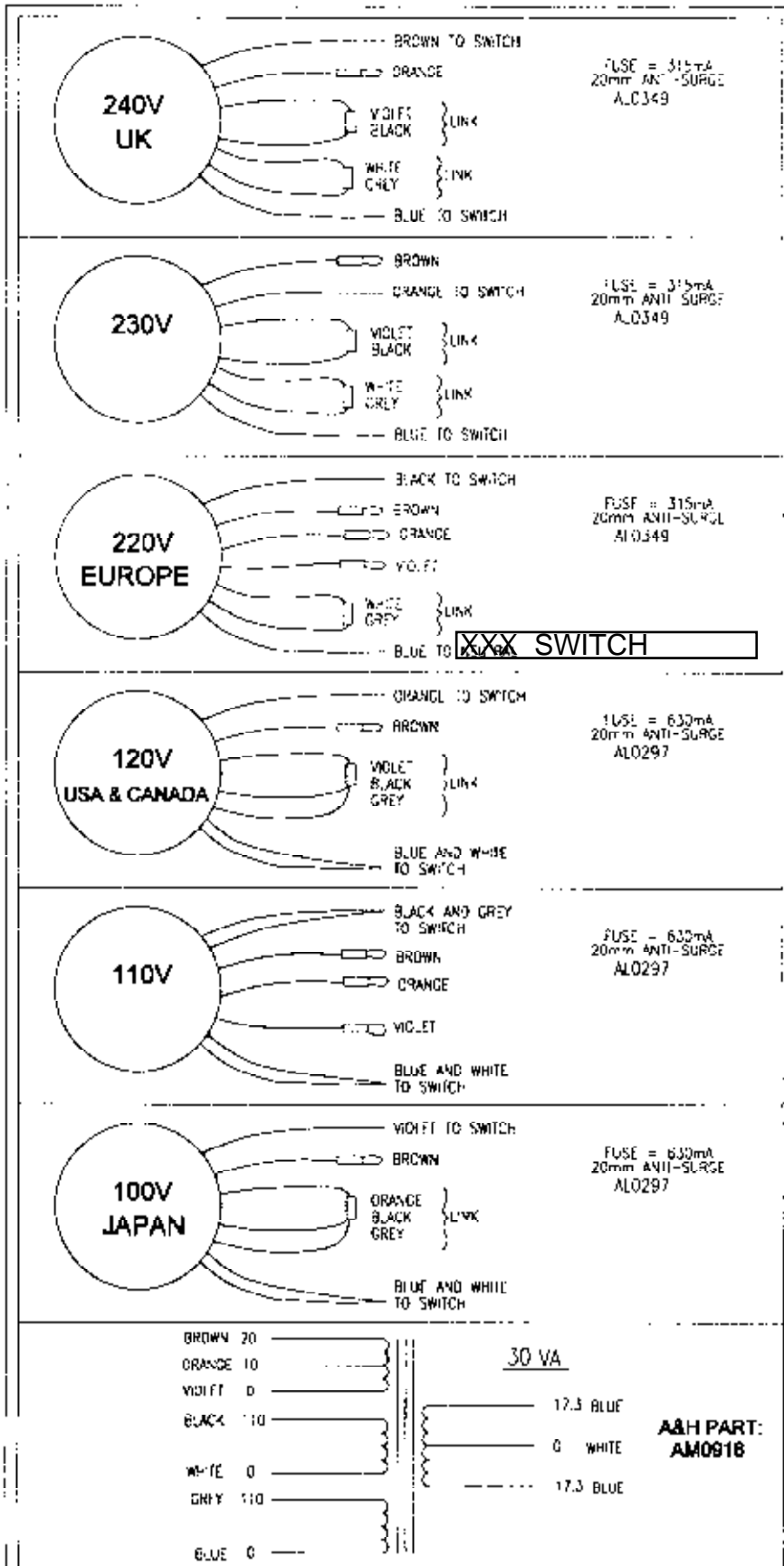



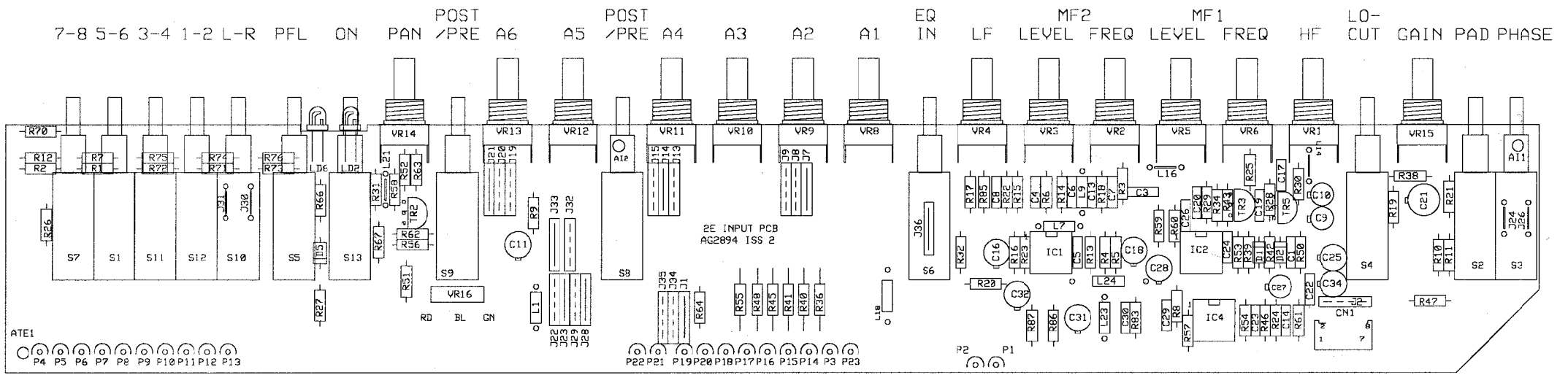

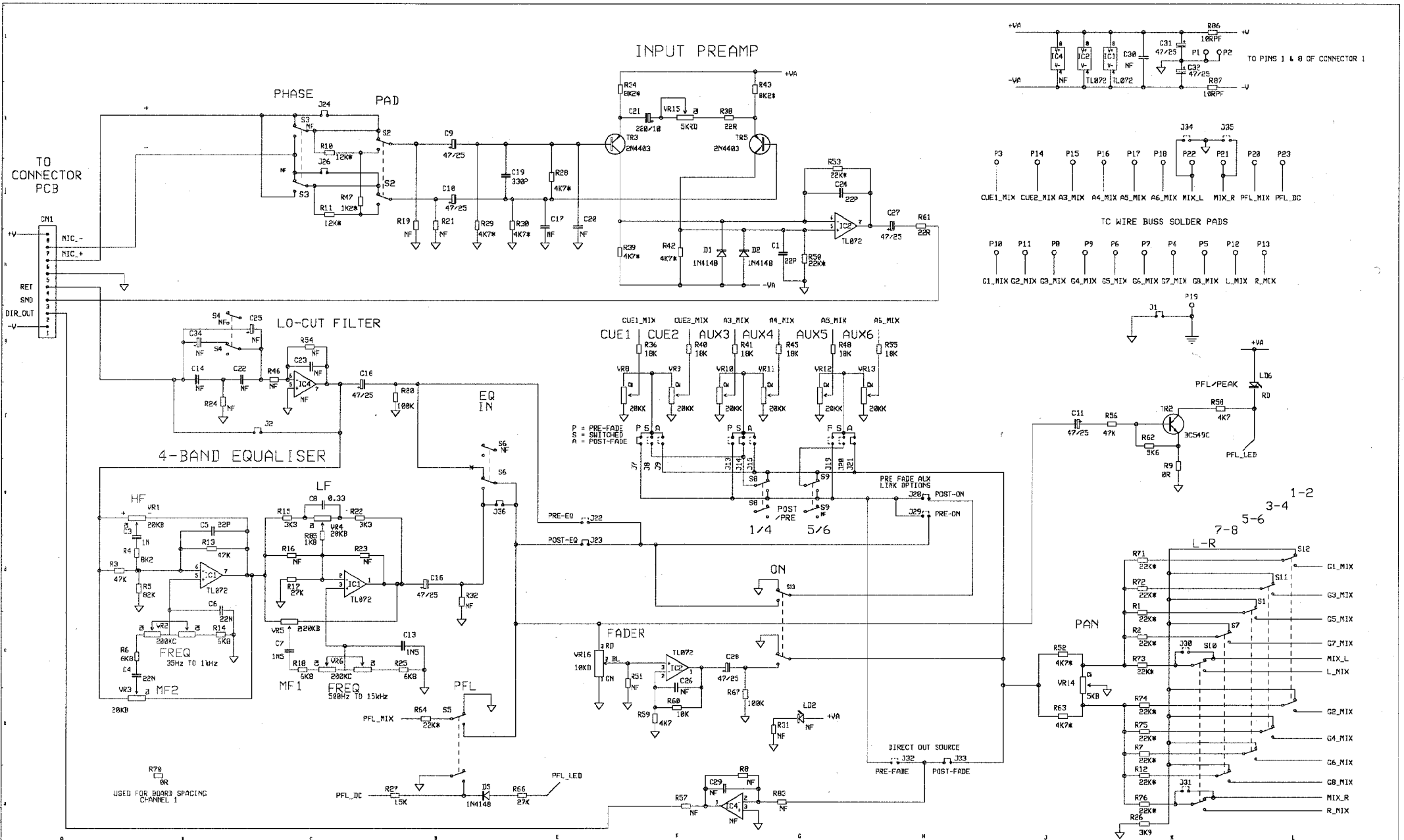

ISS.	REVISION	BY DATE	NOTES
A	ORIGIN	DWD 01/04/97	1. RESISTORS MARKED # ARE 1% ALL OTHERS ARE 5% UNLESS OTHERWISE MARKED
1	PRODUCTION	DWD 18/04/97	2. ELECTROLYTIC CAPACITORS ARE µF UNLESS OTHERWISE MARKED 3. DO NOT MODIFY THIS CCT. WITHOUT REFERENCE TO OTHER WIZARD INPUT CCTS.

UNIT TITLE	MANUFACTURED IN (ENGLAND BY)
2E-8	ALLEN & HEATH
R/G334	DRAWING No. C2894
ISSUE 1	1

DRAWING TITLE	ISSUE	PCB TYPE
INPUT CIRCUIT DIAGRAM	1	AG2894



100-001

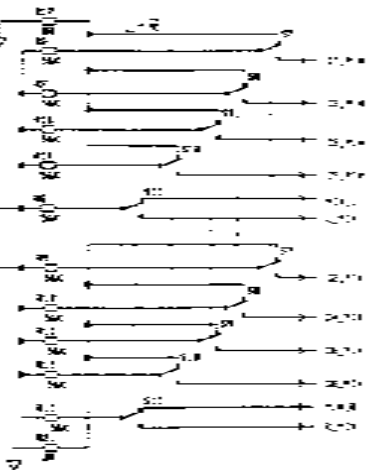
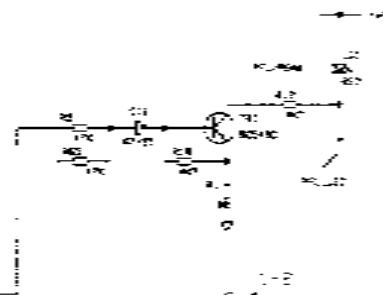
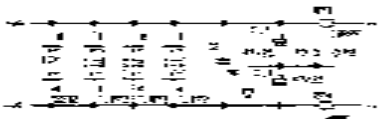

100-002

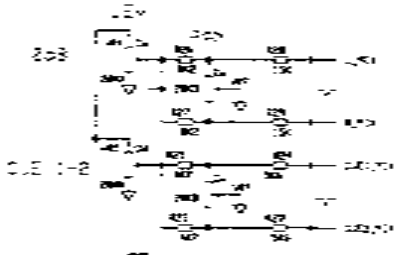
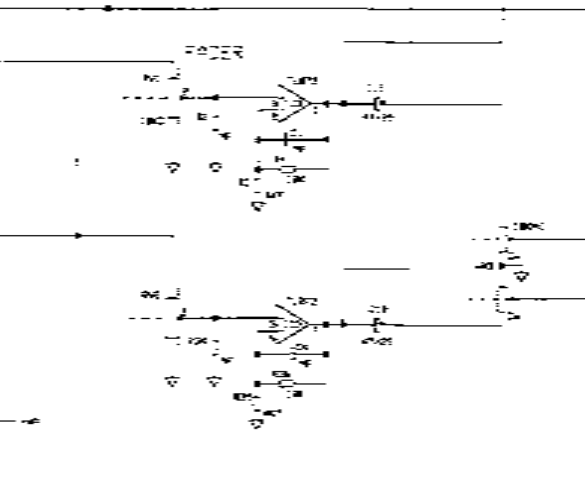
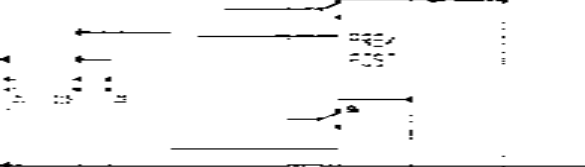
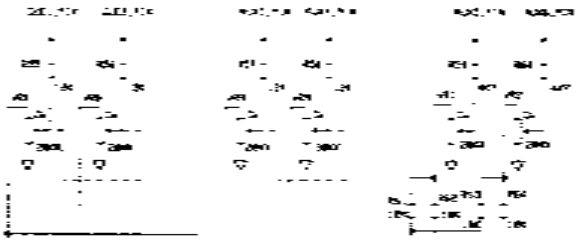

100-003

100-004

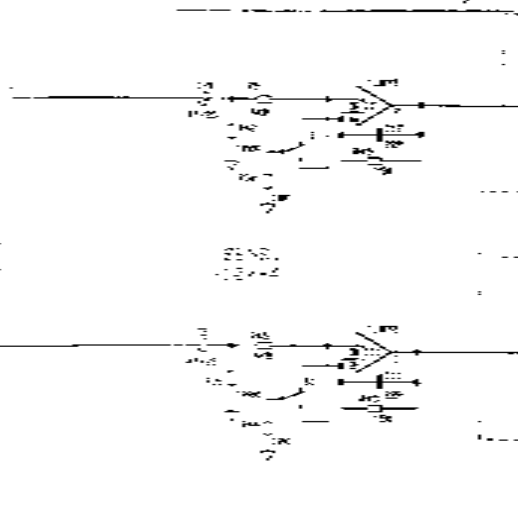

100-005

100-006

100-007

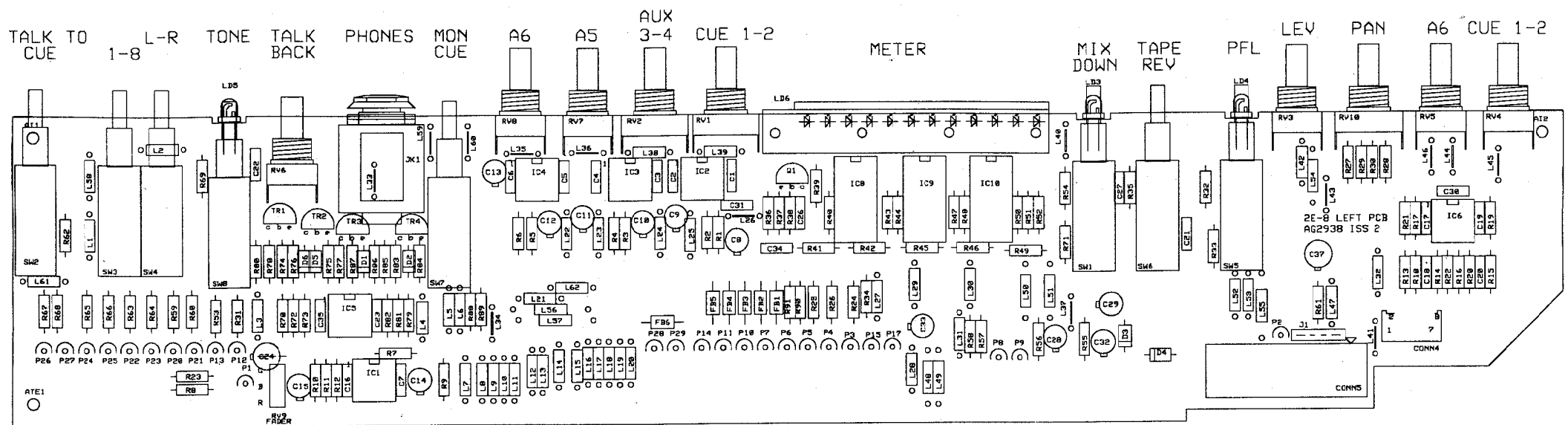

RE-DO LEFT PCB  
A62938 ISS 2

CONN4

CONNS

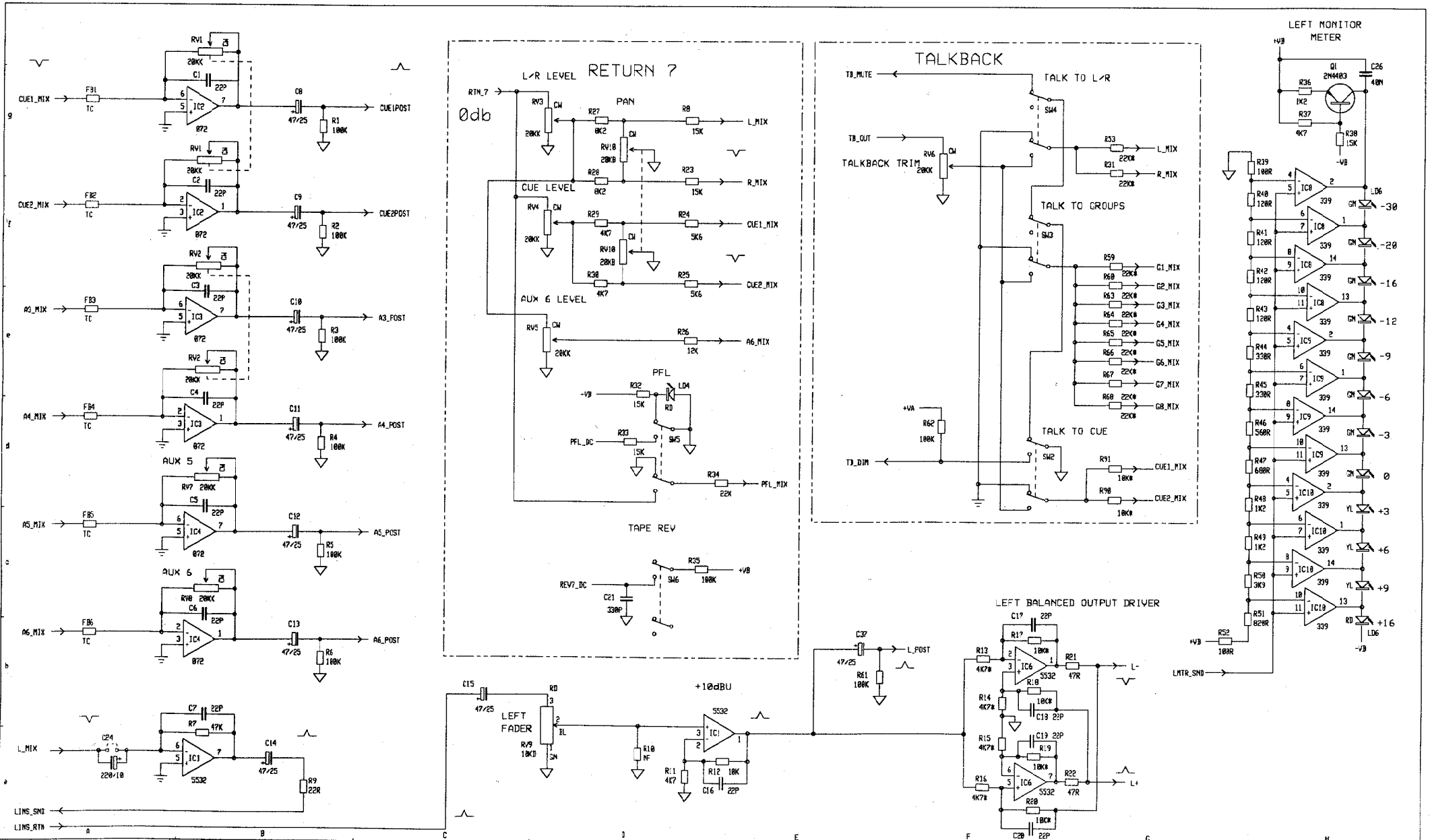

ISS.	REVISION	BY	DATE	NOTES
A	ORIGIN	ARJ	7-3-97	1. RESISTORS MARKED $\mu$ ARE 1% ALL OTHERS ARE 5% 1/4W UNLESS OTHERWISE MARKED 2. ELECTROLYTIC CAPACITORS ARE $\mu$ F-VOLTS
1	PRODUCTION	DRP	16-4-97	
2	C24 ADDED; CONN4 L-, L+ PINS SWAPPED	DRP	15-5-97	

UNIT TITLE	2E-8	MANUFACTURED IN ENGLAND BY	RC316
DRAWING TITLE	LEFT PCB	SHEET 1 OF 2	
		DRAWING No.	C2938
		ISSUE	2

DRAWING No. C2938		ISSUE 2	A2
-------------------	--	---------	----



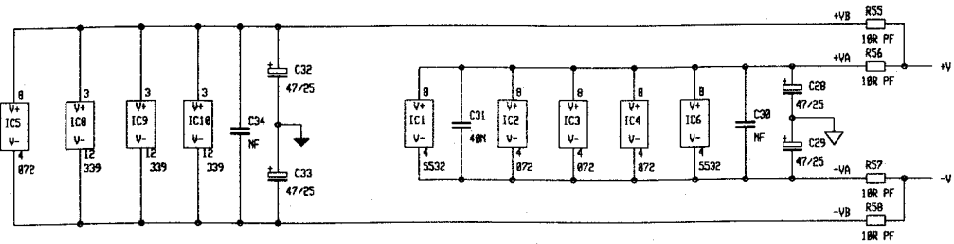

- G1\_MIX — P20
- G2\_MIX — P21
- G3\_MIX — P22
- G4\_MIX — P23
- G5\_MIX — P24
- G6\_MIX — P25
- G7\_MIX — P26
- G8\_MIX — P27
- L\_MIX — P13
- R\_MIX — P12
- MIX\_L — P28
- MIX\_R — P29

TC BUS

- CUE2\_MIX — P4
- CUE1\_MIX — P3
- A3\_MIX — P5
- A4\_MIX — P6
- A5\_MIX — P7
- A6\_MIX — P18
- PFL\_MIX — P11
- PFL\_DC — P15
- P14

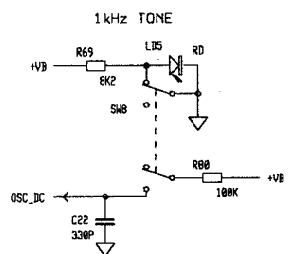
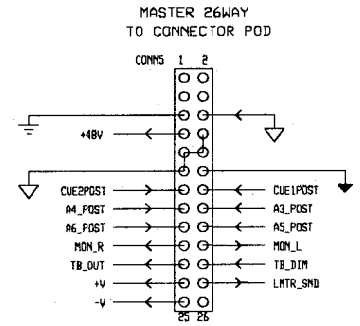
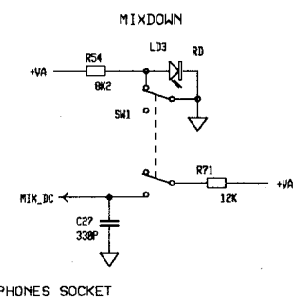
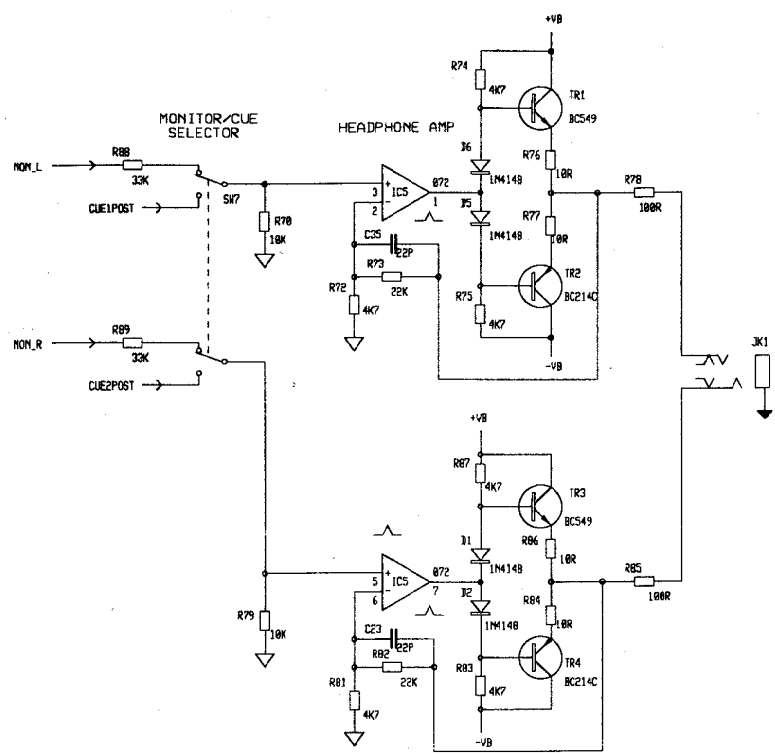
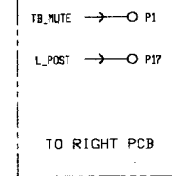

8WAY TO CONNECTOR PCB

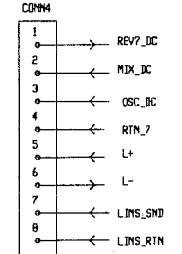

ISS.	REVISION	BY	DATE	NOTES
A	ORIGIN	ARJ	7-3-97	1. RESISTORS MARKED * ARE 1% ALL OTHERS ARE 5% 1/4W UNLESS OTHERWISE MARKED
1	PRDUCTION	DRP	15-4-97	
2	C24 ADDED CONN4 L-,L+ PINS SWAPPED	DRP	15-5-97	2. ELECTROLYTIC CAPACITORS ARE 16V/VOLTS

UNIT TITLE	2E-8	SHEET 2 OF 2
DRAWING TITLE	LEFT PCB	

MANUFACTURED IN ENGLAND BY	ALLEN & HEATH	RG316
DRAWING No.	C2938	ISSUE 2

MONITOR

LEVEL MONO 2TK2 A6 A3-4 PFL RIGHT MONITOR METER PHANTOM TAPES PFL LEV PAN A6 CUE1-2  
2TK1 A5 CUE1-2 +48V ON REV POWER ON

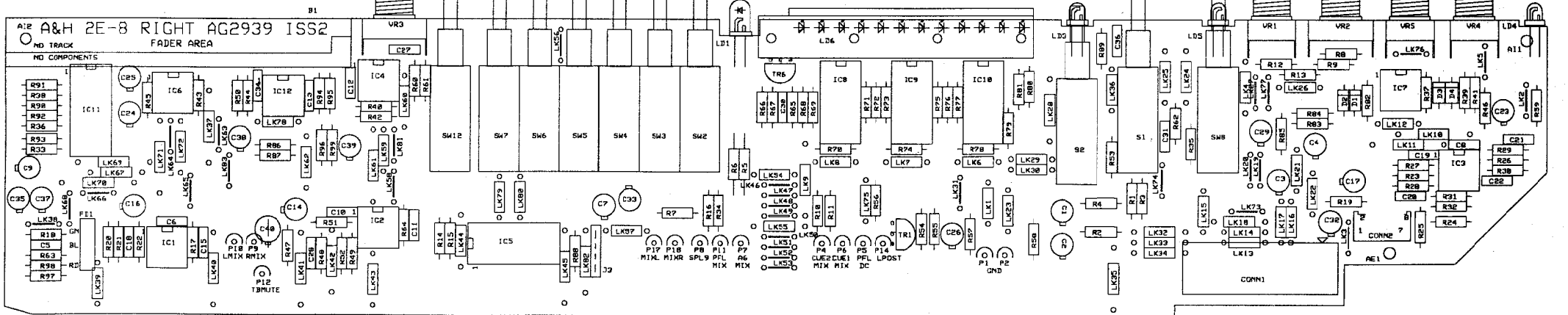

# POWER SUPPLY FILTERING

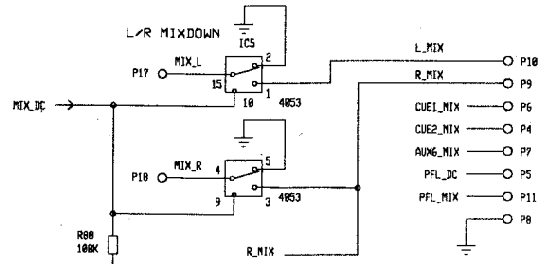
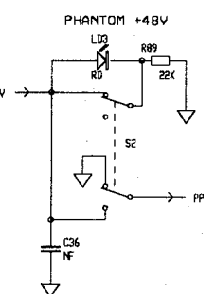
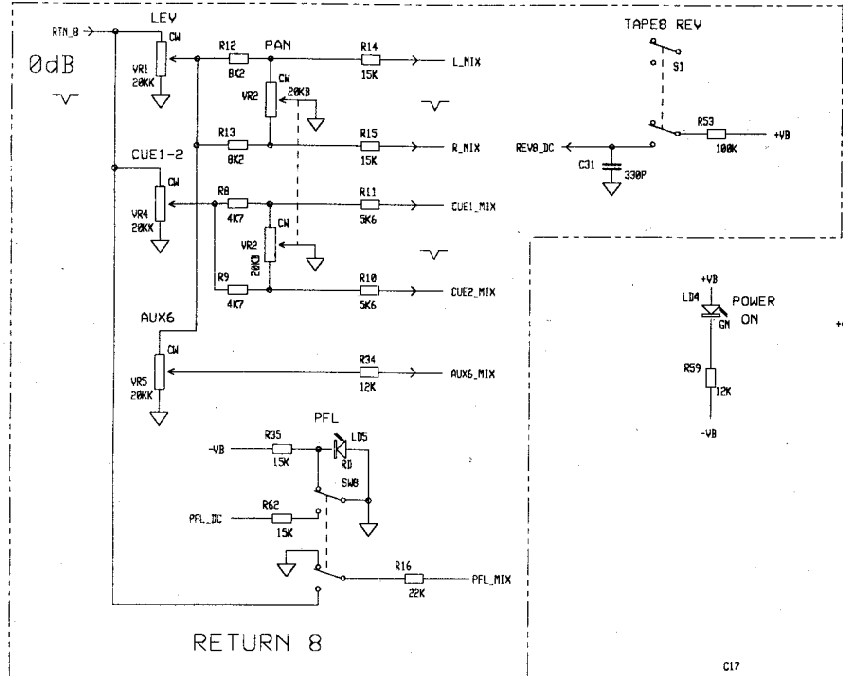
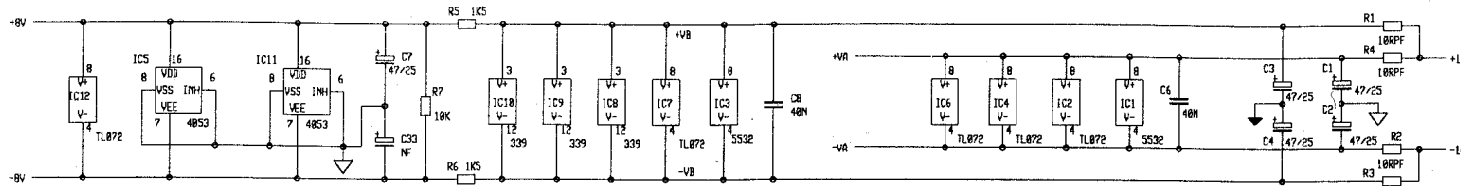

## TC BUS

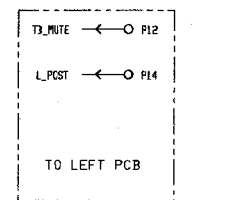

## RIGHT BALANCED OUTPUT DRIVER

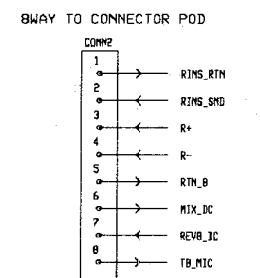
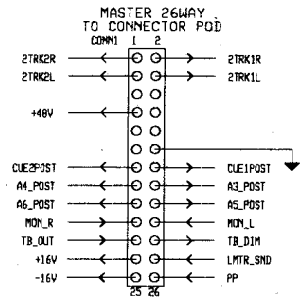
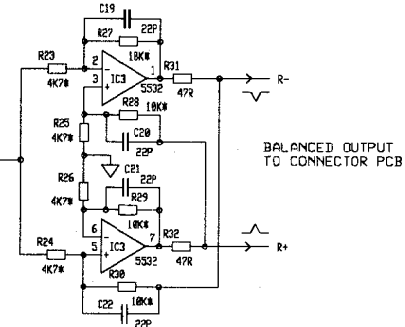

ISS.	REVISION	BY	DATE	NOTES
1	ORIGIN PRODUCTION	ARJ	27/3/97	1. RESISTORS MARKED * ARE 1% ALL OTHERS ARE 5% 1/4W UNLESS OTHERWISE MARKED 2. ELECTROLYTIC CAPACITORS ARE µF/VOLTS
2	C40 ADDED	DLP	11/4/97	
	IC12 PAR WAS+ & -VA	DRP	16/5/97	

UNIT TITLE  
**2E-8** PAGE 1 OF 2

DRAWING TITLE  
**RIGHT PCB**

MANUFACTURED IN ENGLAND BY  
**ALLEN & HEATH**

DRAWING No. **C2939** ISSUE **2**

REF ID: A2

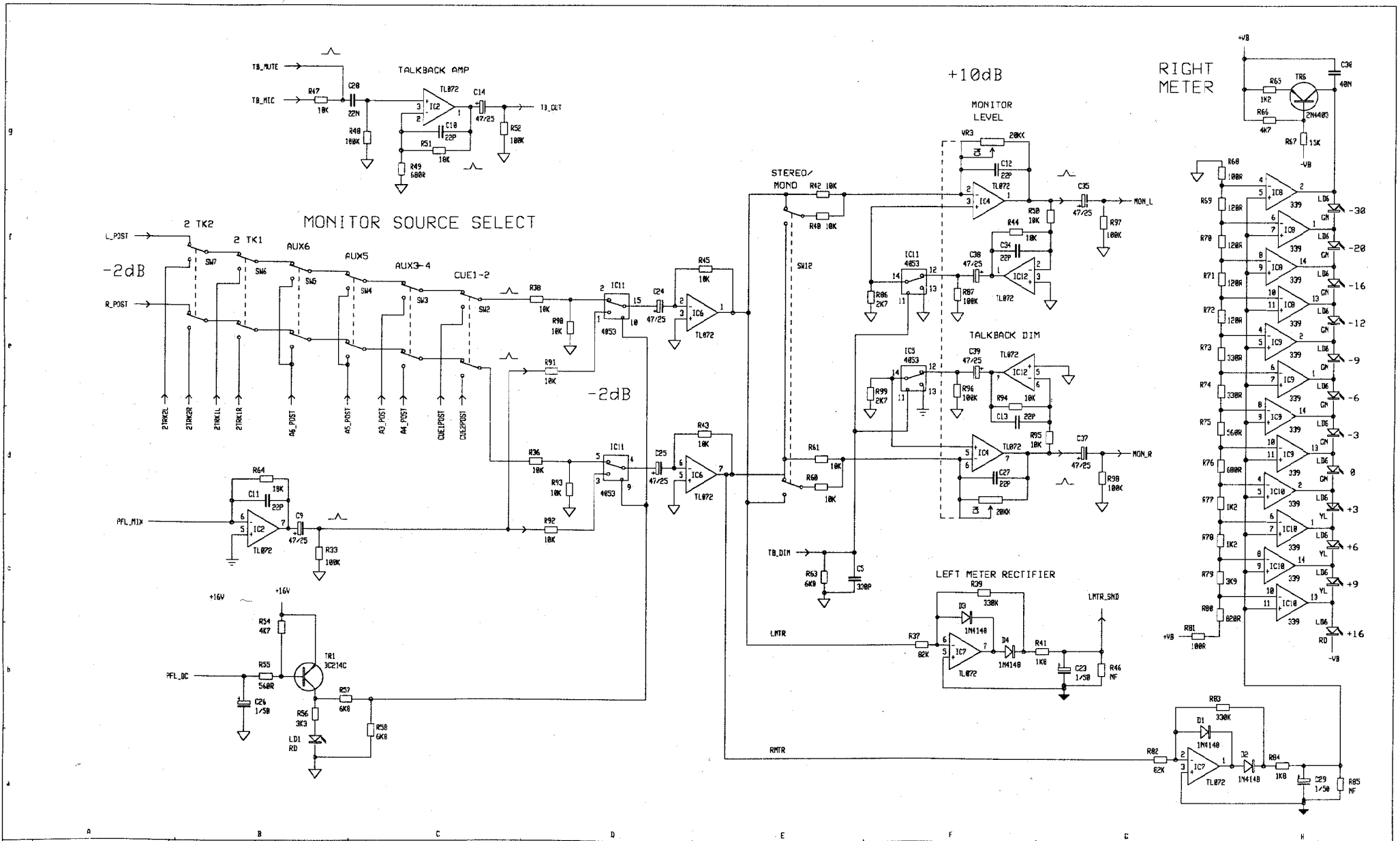

JSS.	REVISION	BY	DATE
1	ORIGIN	ARJ	27/3/97
2	PRODUCTION	DLP	11/4/97
	C40 ADDED	DRP	16/5/97
	IC12 PWR WAS+ & -VA		

NOTES

- RESISTORS MARKED \* ARE 1% ALL OTHERS ARE 5% 1/4W UNLESS OTHERWISE MARKED
- ELECTROLYTIC CAPACITORS ARE  $\mu$ F/VOLTS

UNIT TITLE  
 2E-8 PAGE 2 OF 2

DRAWING TITLE  
 RIGHT PCB

MANUFACTURED IN ENGLAND BY  
 ALLEN & HEATH  
 RG334

DRAWING No. C2939 ISSUE 2

CH 19 CH 17 CH 15 CH 13 CH 11 CH 9 CH 8 CH 7 CH 6 CH 5 CH 4 CH 3 CH 2 CH 1  
 CH 20 CH 18 CH 16 CH 14 CH 12 CH 10

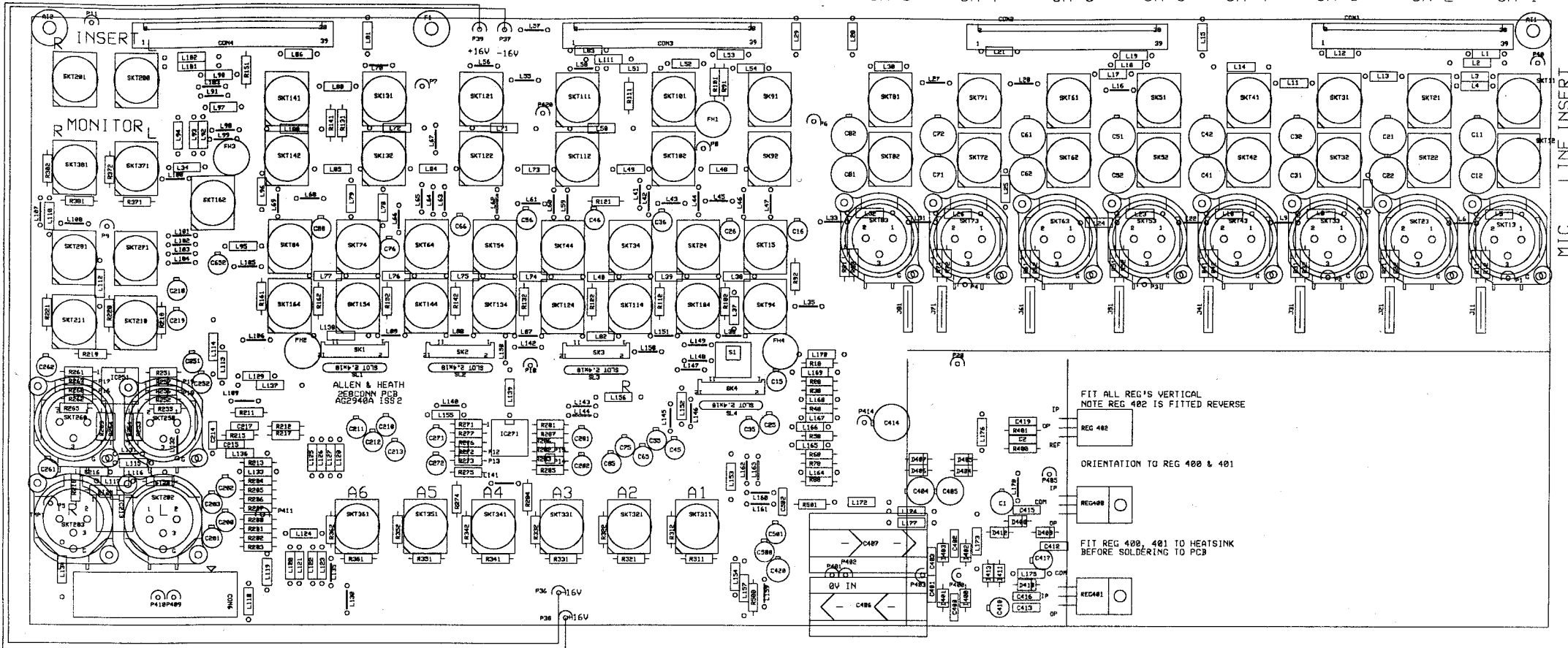

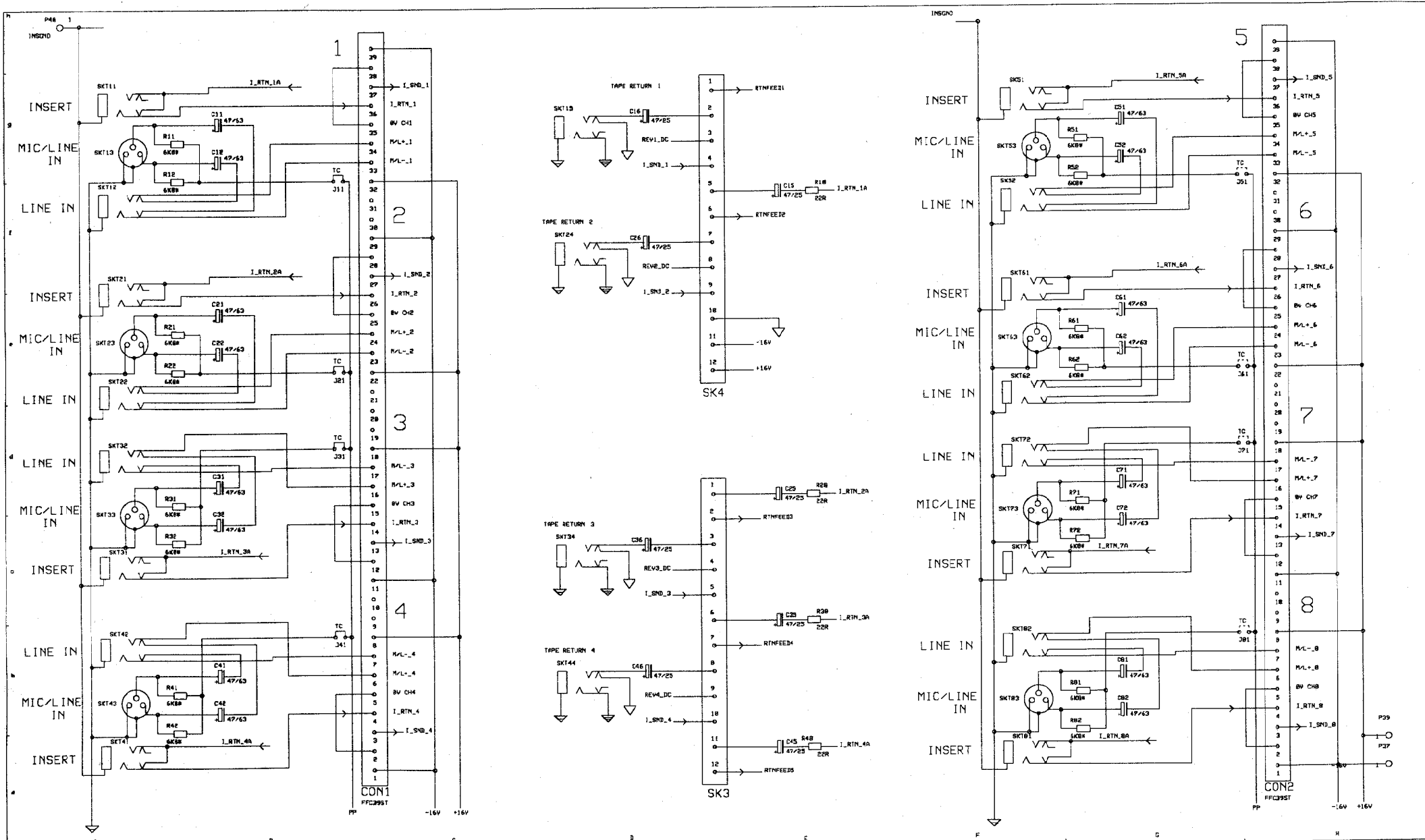

ISS.	REVISION	BY	DATE	NOTES	UNIT TITLE	MANUFACTURED IN ENGLAND BY
1	ORIGIN PRODUCTION	AAT	03-04-97	1. RESISTORS MARKED R ARE 1% ALL OTHERS ARE 5% 1/4W UNLESS OTHERWISE MARKED	2E8	ALLEN & HEATH
2	PHASE CORRECTION	AAT	16-04-97		DRAWING TITLE	DRAWING No.
3	PHANTOM PWR MOD	DWD	27-05-97	2. ELECTROLYTIC CAPACITORS ARE µF/VOLTS	CONNECTOR/PSU PCB	C2940A
					PCB TYPE AC2940A	ISSUE 3
						A2

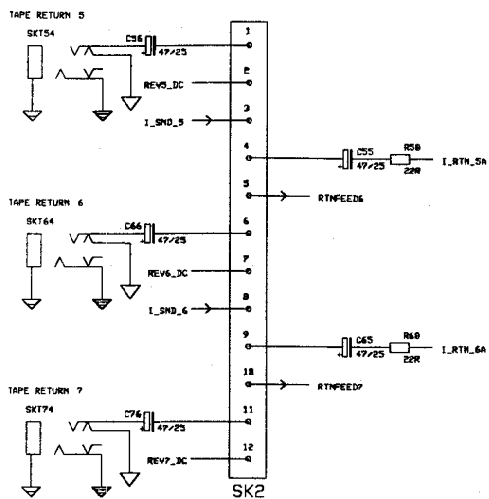

### BALANCED OUTPUT

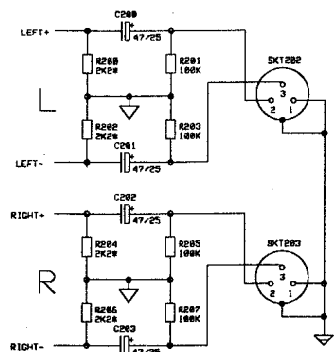

### 2 TRACK 1 IN

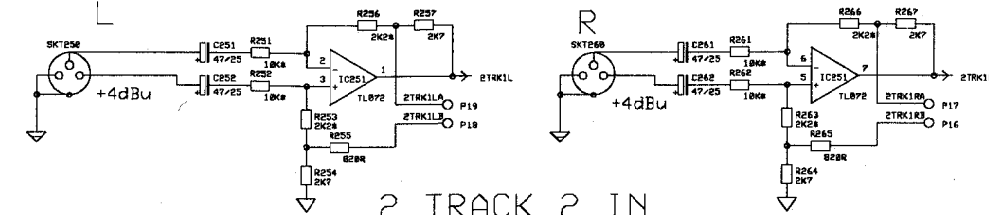

### 2 TRACK 2 IN

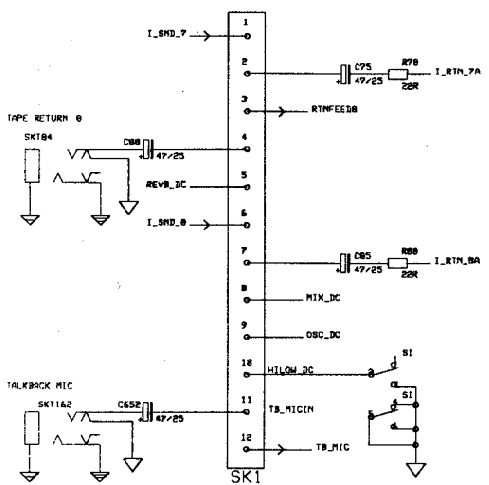
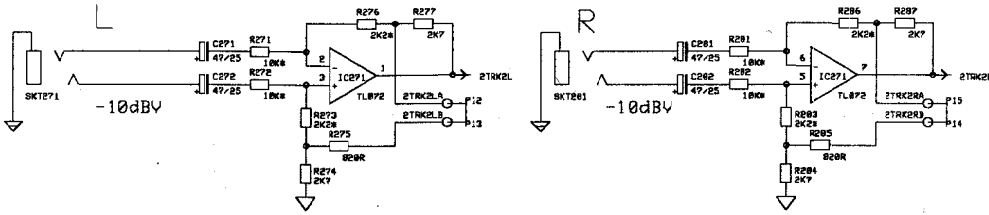

### L & R INSERT

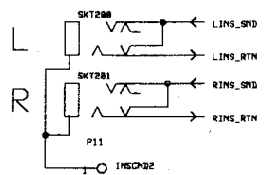

### MONITOR

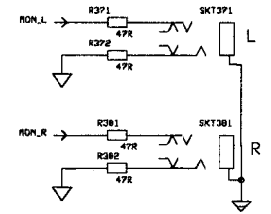

### CUE 1-2

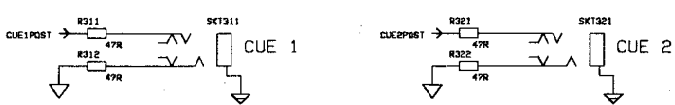

### AUX OUT 3-6

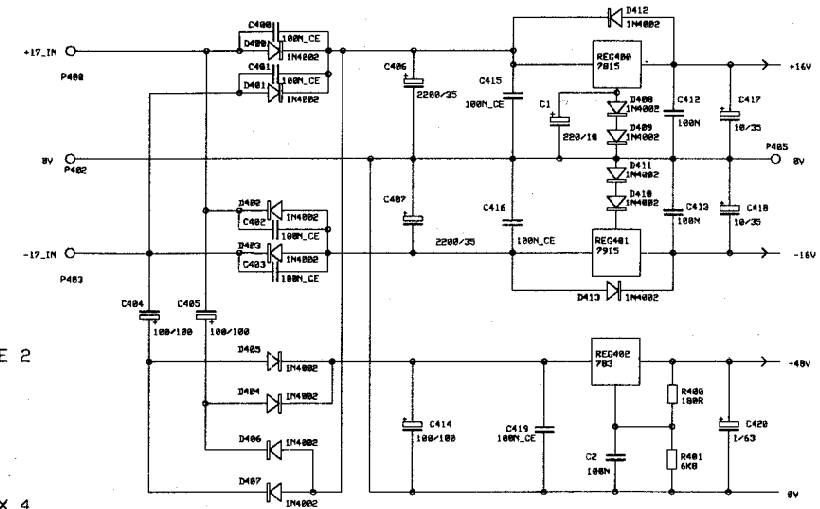
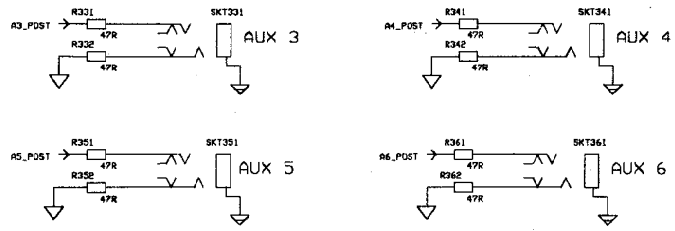

### EDGE PIN

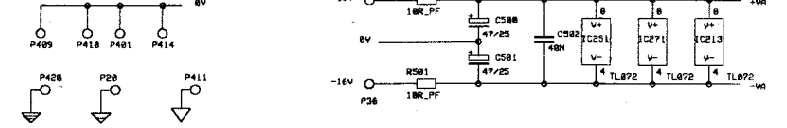

ISS.	REVISION	BY	DATE
A	ORIGIN	AA1	03-04-97
1	PRODUCTION	AA1	16-04-97
2	PHASE CORRECTION	AA1	22-05-97
3	PHANTOM PWR MOD	DWD	27-05-97

NOTES

- RESISTORS MARKED # ARE 1% ALL OTHERS ARE 5% 1/4W UNLESS OTHERWISE MARKED
- ELECTROLYTIC CAPACITORS ARE µF/VOLTS

UNIT TITLE: 2E8  
 DRAWING TITLE: CONNECTOR/PSU PCB  
 PCB TYPE: AG2940A

MANUFACTURED IN ENGLAND BY  
 ALLEN & HEATH  
 DRAWING No. C2940A ISSUE 3

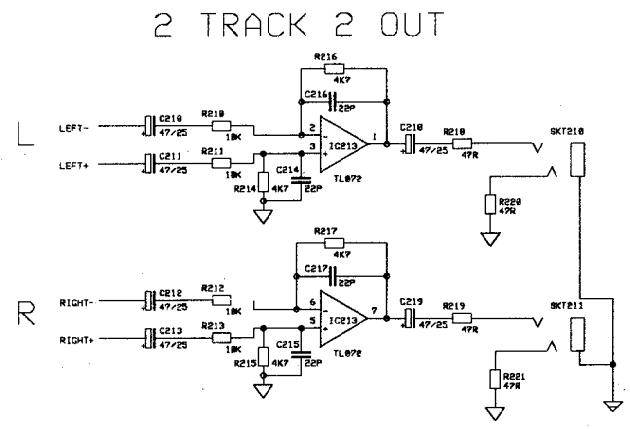
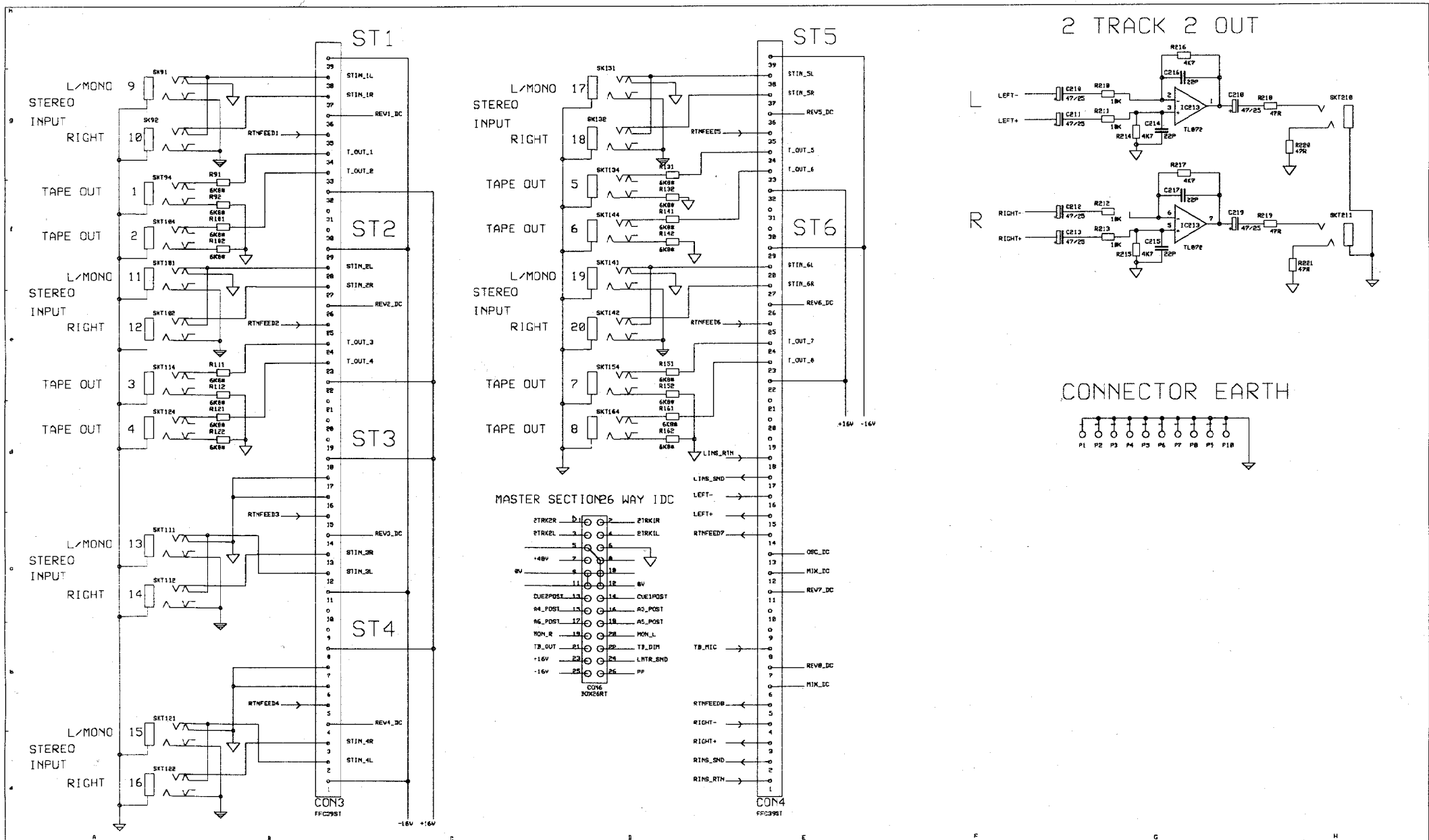

CONNECTOR EARTH

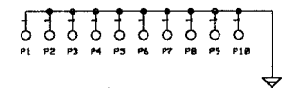

MASTER SECTION 26 WAY IDC

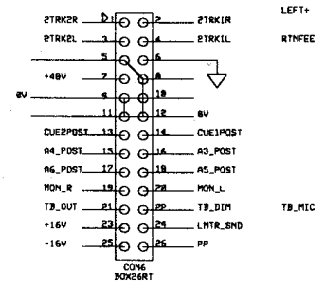

ISS.	REVISION	BY	DATE	NOTES
A	ORIGIN	AAT	03-04-97	
1	PRODUCTION	AAT	16-04-97	
2	PHASE CORRECTION	AAT	22-05-97	
3	PHANTOM PWR MOD	DWD	27-05-97	

1. RESISTORS MARKED \* ARE 1%  
 ALL OTHERS ARE 5% 1/4W UNLESS OTHERWISE MARKED

2. ELECTROLYTIC CAPACITORS ARE µF/VOLTS

UNIT TITLE 2E8

DRAWING TITLE CONNECTOR/PSU PCB

PCB TYPE AG2940A

MANUFACTURED IN ENGLAND BY ALLEN & HEATH

DRAWING No. C2940A ISSUE 3





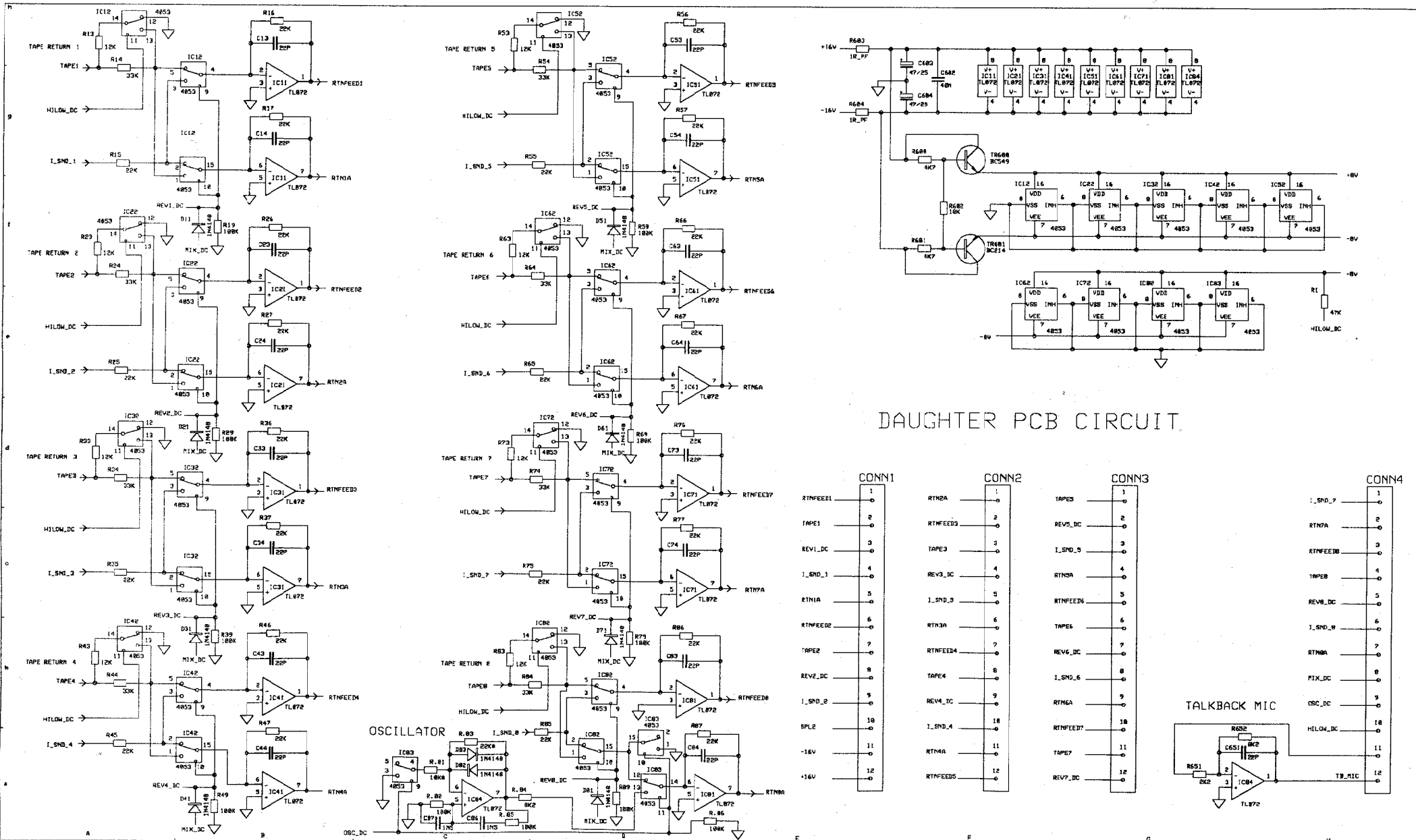

DAUGHTER PCB CIRCUIT

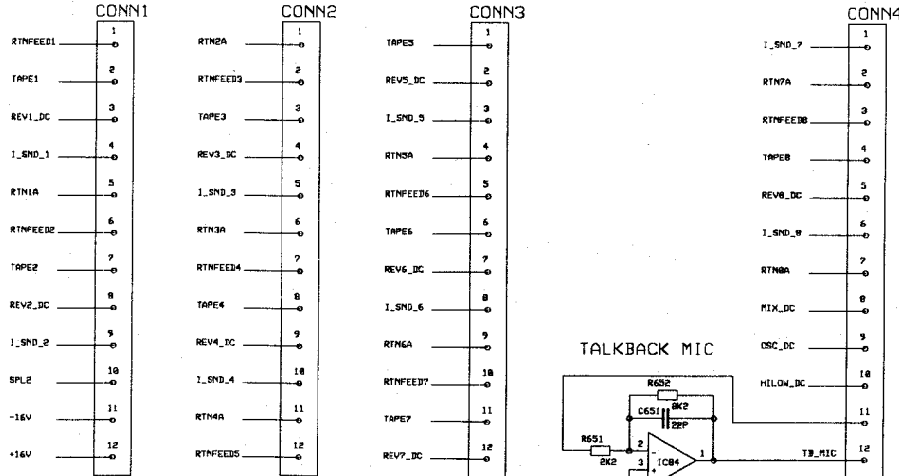

ISS.	REVISION	BY	DATE	NOTES	UNIT TITLE	MANUFACTURED IN ENGLAND BY
A	ORIGIN PRODUCTION	AAI	04-04-97	1. RESISTORS MARKED R ARE 1% ALL OTHERS ARE 5% 1/4W UNLESS OTHERWISE MARKED	2E8	ALLEN & HEATH
1	VALUE CHANGE/ RE-PACKED IC'S	AAI	17-04-97	2. ELECTROLYTIC CAPACITORS ARE AF-VOL'S	CONNECTOR PCB	
		ARJ	29-4-97		PCB TYPE AG2940B	DRAWING No. C2940B ISSUE 1

# BLOCK DIAGRAM

