

EX4500 & EX6100



Installation and Service Manual

Please fill in for future reference:

MODEL: _____

SERIAL NUMBER: _____

DATE PURCHASED: _____

* Please fill out the warranty registration card in this manual.

EasyPro
EX4500
S/N: XXXX-XXXXXX

Same label
example for
EX6100

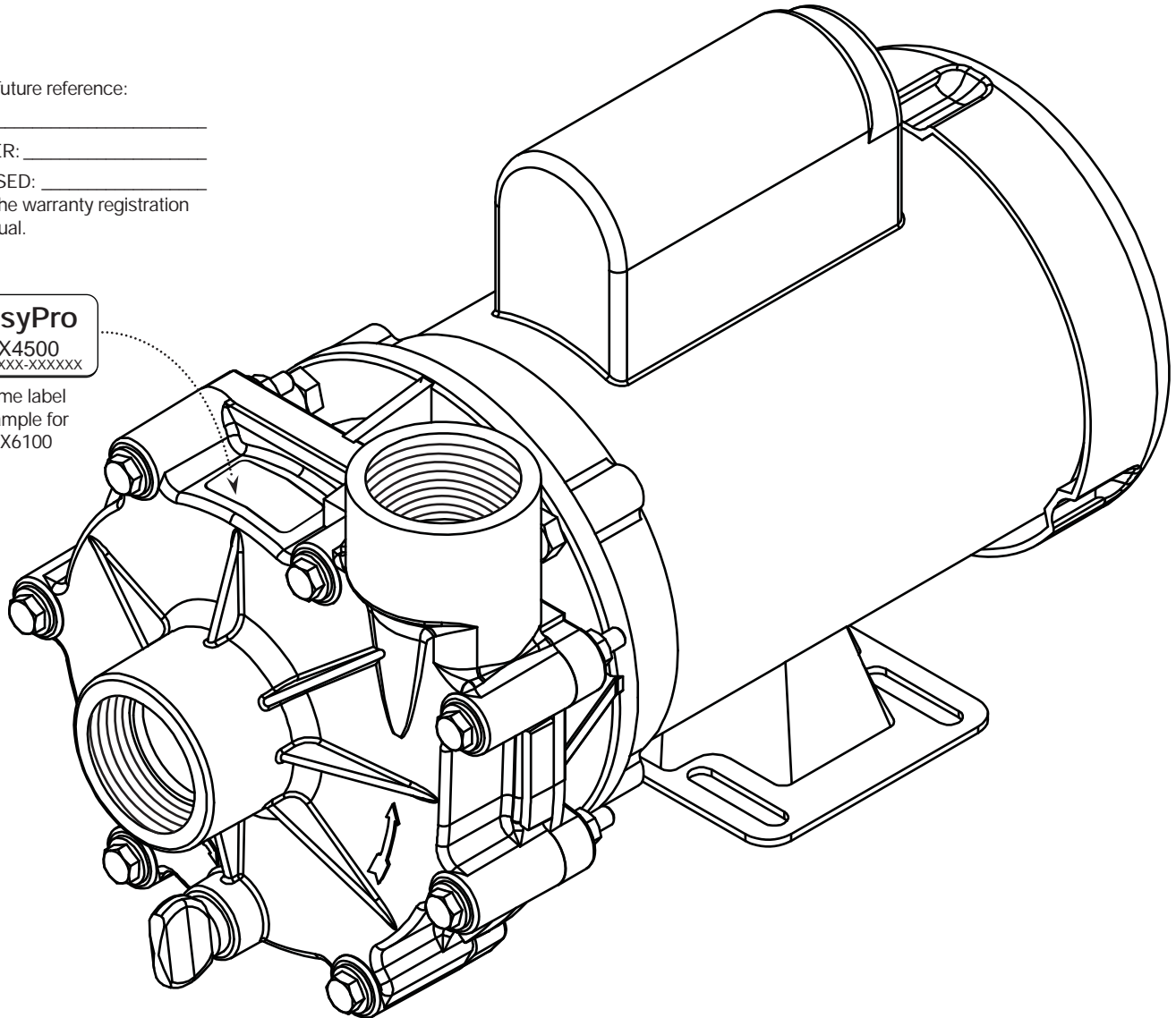

TYPE: STRAIGHT CENTRIFUGAL
MOTOR: NEMA C Face, 56J
HORSEPOWER: 1/8, 1/6, 1/4, 1/3 (1750 RPM)
VOLTAGE: 115/230

INLET: 1 1/2" FNPT
DISCHARGE: 1 1/2" FNPT
MATERIAL: 40% Glass-Filled
Polypropylene

HARDWARE: STAINLESS STEEL
ACCESORIES: 90 CUBIC INCH STRAINER BASKETS (1 1/2" & 2"),
SWING Check ValveS (1 1/2", 2", 3")
500 CUBIC INCH STRAINER BASKETS
(1 1/2", 2", 3")

WARNING: Please read completely before you install or operate your new pump! This is an external "out-of-pond" pump!
It is NOT submersible! Do NOT allow this pump to become submerged! Never run dry! Max. case pressure.- 65 PSI!



Reliability You Can Count On!

© 2010 EasyPro, Inc

Pg. 1

EX4500 & EX6100

We congratulate you on your choice of the EX4500/EX6100 Centrifugal Pump! It has been carefully designed using the advantages of today's technology and carefully constructed to give you the dependability of yesterday. To insure proper performance, we urge you to carefully follow the instructions in this manual. If you have any questions, call your nearest distributor or EasyPro for assistance.

INSTALLATION

Please read carefully! When properly installed the EX Series Pump will provide dependable trouble-free service.

1. Locate the pump as near the water source as possible. A flooded suction situation is preferred. The pump is not self-priming, therefore, if the fluid level is below the pump, a swing check valve must be installed and the pump primed prior to start-up. (Figure 2)
2. Mount motor base to a secure, immobile foundation.
3. Use only plastic fittings on both the intake and discharge ports. Seal pipe connections with Teflon™ paste. These fittings should be self-supported and in neutral alignment with each port. (i.e. Fittings must not be forced into alignment which may cause premature line failure or damage to the pump volute.) For non-flooded installations, a strainer basket and check valve are recommended.
4. Never restrict the intake. Keep both input and discharge lines as free of elbows and valves as possible. Always use pipe of adequate diameter. This will reduce friction losses and maximize output.
5. This pump is not self-priming! It must not be run dry! We recommend a flooded suction installation. Please read carefully! When properly installed, the pump will provide dependable, trouble-free service.

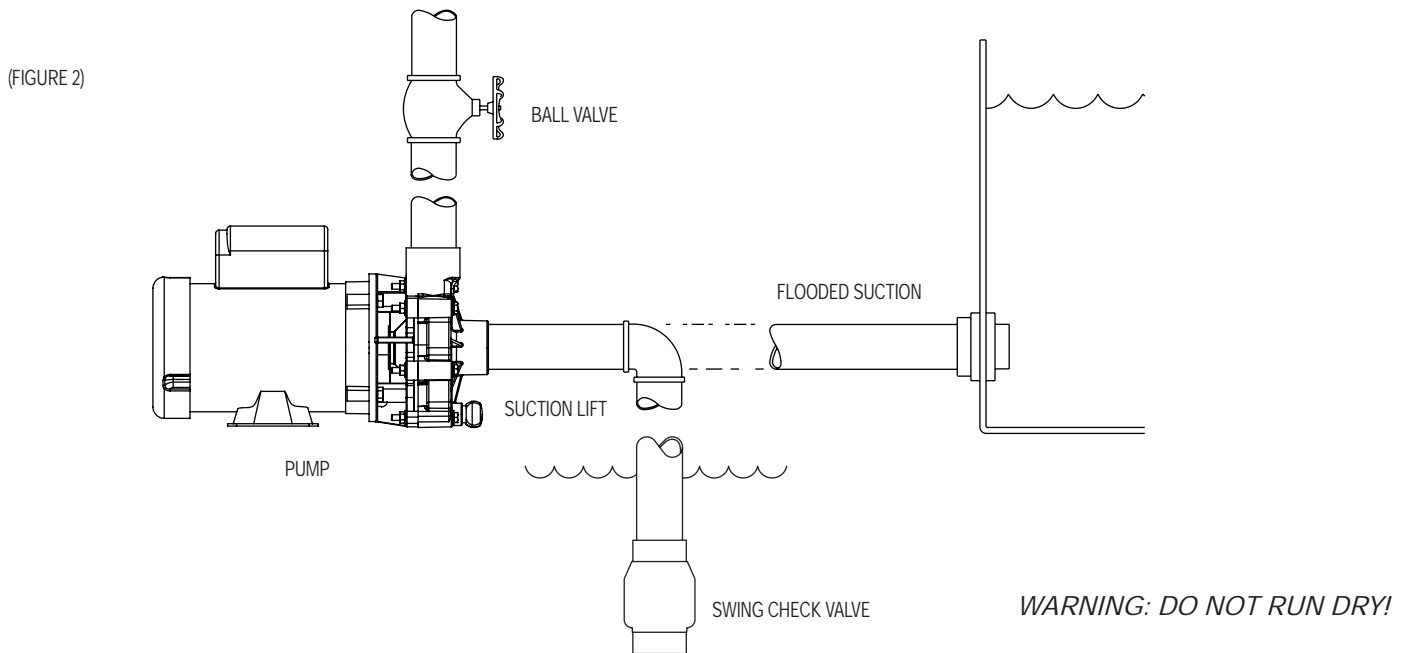

 **WARNING: ALWAYS SHUT OFF ELECTRICAL POWER BEFORE INSTALLATION AND / OR SERVICING THIS PUMP! ALL ELECTRICAL WIRING SHOULD MEET STATE AND LOCAL ORDINANCES. IMPROPER WIRING MAY NOT ONLY BE A SAFETY HAZARD BUT MAY PERMANENTLY DAMAGE THE MOTOR AND/OR PUMP! 230V 50 HZ MOTORS AVAILABLE - CONTACT YOUR SUPPLIER FOR INFORMATION.**

ELECTRICAL HOOK-UP

1. Check that supply voltages match the motor's requirements.
2. Check motor wiring and connect, according to instructions on motor, to match supply voltage.
3. Power cord should be protected by conduit or by cable and be of proper gauge. It should be no longer than necessary.
4. Power should be drawn directly from a box with circuit breaker protection or with a fused disconnect switch.



EX4500 & EX6100

PUMP END ASSEMBLY

1. Clean and inspect all pump parts (O-ring, seal seats, motor shaft, etc.).
2. Apply sealant to the bracket bore ID wall and around the seal case - follow sealant mfg. instructions. We recommend using Gas-gacinch®. Silicone sealant can also be used.
3. Press carbon graphite seal into bracket while taking care not to damage carbon graphite face.
4. Place slinger (rubber washer) over motor shaft and mount bracket to motor.
5. Carefully, lubricate the seal seat elastomer OD and impeller hub ID with water. Press the seal seat into the impeller hub making certain that the ceramic is in evenly — the sealing surface should be parallel with the impeller hub.
6. Carefully lubricate carbon-graphite and ceramic sealing surfaces with CLEAN water. Do not use silicon lubricants or grease!
7. Assemble bracket to motor with four M-bolts
8. Thread impeller onto shaft and tighten! If required, remove motor end-cap and use a screwdriver on the back of motor shaft to prevent shaft rotation while tightening. Replace motor end cap.
9. Seat large O-ring in volute slot and assemble volute to bracket with seven 1/4-20 x 2 3/4" hex cap screws, washers and nuts. Tighten in a cross pattern (30 in-lbf).
10. Install drain plug with its O-ring in volute drain hole.
11. Before operating pump, allow a proper cure time for the sealant used in step 2.

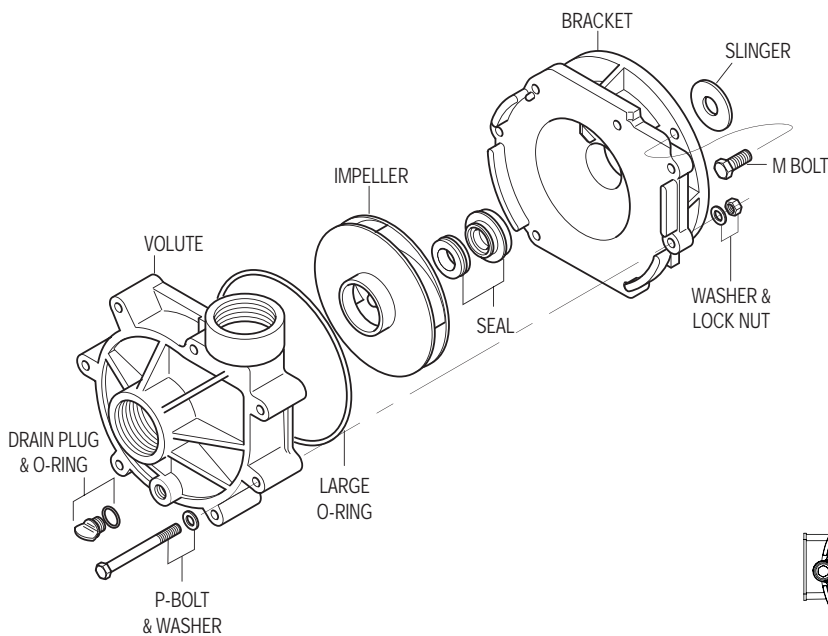

DESCRIPTION	MDM P/N
DRAIN PLUG	1000.110 LG
O-RING, DRAIN PLUG	E014B70
VOLUTE	K000.070 LG
LARGE O-RING	1000.061
IMPELLER	1000.05__*
SEAL - BRASS	1000.0415
SEAL - SS316	1000.0414
BRACKET	K000.030 LG
SLINGER	1000.010V
HARDWARE KIT	1000.502

Note: These part numbers are only for standard models within the EX series. Consult factory for impeller part number.

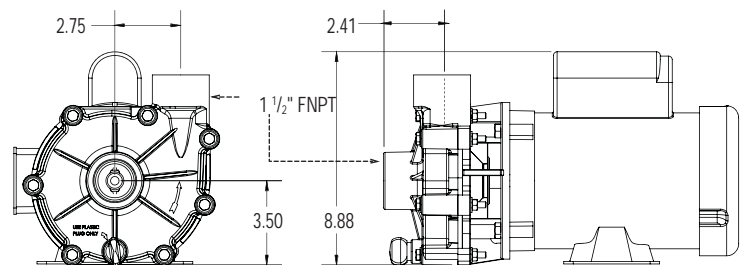

MOTOR ILLUSTRATION IS FOR REFERENCE ONLY.

DISASSEMBLY

1. Shut off power to motor before disconnecting any electrical wiring from the back of the motor.
2. Disassemble volute from bracket by removing the seven 1/4" - 20 threads per inch x 2 3/4" hex cap screws.
3. Remove cap covering shaft at back of motor and with a large screwdriver, prevent shaft rotation while unscrewing impeller.
4. Remove ceramic piece from impeller. (If you are replacing the seal)
5. Detach bracket from motor.
6. Remove carbon-graphite seal from bracket by pressing out from the back. Do not dig out from the front! (If you are replacing the seal)



EX4500 & EX6100

MAINTENANCE

Lubrication

Motor - Permanently Lubricated ball bearings - no service required.

Rotary Seal - Requires no lubrication after assembly.

**The pump must be drained before servicing or if stored below freezing temperatures. Periodic replacement of seals may be required due to normal carbon wear.*

Symptom	Problem	Resolution
No Flow	Insufficient Prime	Prime system with water and purge all air from suction piping.
		Install check valve.
	Insufficient Power	Verify power supply and connection from panel to pump.
		Verify proper voltage. Some models are dual voltage (115/230).
	Flow Restriction	Ensure valves are open.
		Ensure plumbing is clear, including suction strainers, check valves, etc.
Verify check valve orientation and direction of permitted flow.		
Air leak	Clean out leaves or other debris from basket strainer (if applicable).	
Air leak	Fix air leaks at fittings, connections, strainer basket etc. This typically occurs on the intake side.	
System Incompatibility	Verify hydraulic compatibility: i.e. pump & pipe are sized for the system.	
Low Flow	Air leak	Fix air leaks at fittings, connections, strainer basket etc. This typically occurs on the intake side.
	System Incompatibility	Verify hydraulic compatibility: i.e. pump & pipe are sized for the system.
	Insufficient Power	Verify power supply and connection from panel to pump.
		Verify proper voltage. Some models are dual voltage (115/230).
	Flow Restriction	Ensure valves are open.
		Ensure plumbing is clear, including suction strainers, check valves, etc.
	Insufficient Prime	Clean out leaves or other debris from basket strainer (if applicable).
		Prime system with water and purge all air from suction piping.
	Cavitation	Verify airtight plumbing on the suction plumbing especially fittings!
Clean out leaves or other debris from basket strainer (if applicable).		
Increase pipe size where possible.		
Sporadic Operation	Insufficient Power	Decrease suction pipe length, reduce the number of elbows, etc.
		Verify hydraulic compatibility: i.e. pump and pipe are sized for the system.
	Poor Ventilation	Verify power supply and connection from panel to pump.
Excessive Noise	Cavitation	Verify proper voltage. Some models are dual voltage (115/230).
		Ensure adequate airflow over motor to prevent overheating.
		Verify airtight plumbing on the suction plumbing especially fittings!
		Clean out leaves or other debris from basket strainer (if applicable).
		Increase pipe size where possible.
	Insufficient Power	Decrease suction pipe length, reduce the number of elbows, etc.
		Verify hydraulic compatibility: i.e. pump and pipe are sized for the system.
	Flow Restriction	Verify power supply and connection from panel to pump.
		Verify proper voltage. Some models are dual voltage (115/230).
Ensure valves are open.		
Flow Restriction	Flow Restriction	Ensure plumbing is clear, including suction strainers, check valves, etc.
		Verify check valve orientation and direction of permitted flow.

EASYPRO LIMITED WARRANTY

This product is warranted to the initial purchaser to be free of defects in materials and workmanship at the time of initial purchase and for a period of 18 months. In the event this product malfunctions within 18 months from the date of purchase, the sole obligation of EasyPro, Incorporated (hereinafter referred to as EP) will be to repair the unit or replace with an equivalent new or factory refurbished unit at EP's discretion, subject to the following conditions:

- You MUST call EP for a return authorization (RA#) number prior to returning, pumps returned without an RA# will be refused.
- The malfunction is proved attributable to a defect in materials or workmanship, including repairs performed under this warranty. Malfunction for any other reason — including but not limited to misuse, negligence, accident, tampering with parts, incorrect wiring, improper installation — will not be remedied under this warranty.
- EP specifically does not guarantee chemical compatibility, and expressly does not warrant units from any problems caused by chemical attack or failure due to incompatibility of fluid being pumped with pump materials of construction.
- All warranty repairs must be performed by EP or an EP authorized company. Purchaser must retain the purchase receipt and present it with this certificate as proof of ownership and entitlement to warranty repairs. Unauthorized repairs will not be compensated by EP, are not the responsibility of EP, and if such repairs damage the product, such damages are not remedied under this warranty.
- Purchaser shall bear all shipping, packing and insurance costs and all other costs, excluding labor and parts necessary to effectuate repairs under this warranty.

- Periodic check-ups are not covered by this warranty.
- This warranty is in lieu of all other express warranties which now or hereafter might otherwise arise with respect to this product. Any and all limited warranties, including the warranties of merchantability and fitness for particular purpose, shall have no greater duration than the duration period of the express written warranty applicable to this product, and shall terminate automatically the expiration of such duration period. Some states do not allow limitations on how long an implied warranty lasts, so the above limitation may not apply to you. No action shall be brought for breach of any implied or express warranty after one year subsequent to the expiration of the duration period of the express written warranty.
- Incidental and consequential damages caused by malfunction, defect, or otherwise, and with respect to breach of any express or implied warranty, are not the responsibility of EP, and, to the extent permitted by law, are hereby excluded both for property damage and, to the extent not unconscionable, for personal injury damage. Some states do not allow the exclusion or limitation of incidental or consequential damages, so the above limitation or exclusion may not apply to you.
- This warranty does not apply to any malfunction arising out of any application of this product other than normal use, unless such application is upon request specifically approved in writing by EP.
- The provisions of this warranty are severable and if any provision shall be deemed invalid, the remaining provisions shall remain in full force and effect.
- Rights under this warranty are not assignable without the express prior consent in writing by EP and, regardless of the terms of such consent in writing, such assignee shall have no greater rights than his assignor had against EP.

Name: _____
 Address: _____
 City: _____ State: _____ Zip: _____
 Model: _____ Serial Number: _____
 Date purchased: _____ Where purchased: _____



EasyPro Pond Products
 4385 East 110th, Grant, MI 49327
 800-448-3873 • 231-834-5537 fax
 www.EasyProPondProducts.com

Activate your warranty by filling out this form and mailing to EasyPro Pond Products

Gasgacinch® is a registered trademark of Porter Manufacturing. Noryl® is a registered trademark of the General Electric Company. Teflon® is a registered trademark of DuPont Company.

Reliability You Can Count On!

© 2010 EasyPro, Inc

Page 4

