

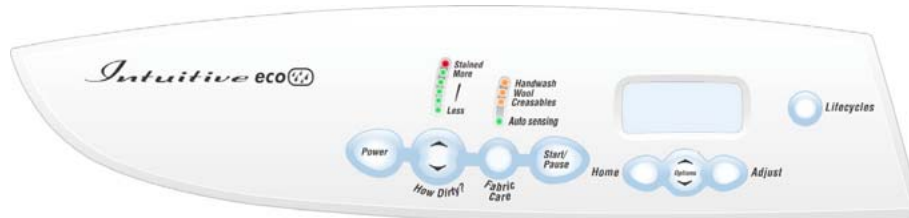

**ELECTRONIC WASHING MACHINE
GWL11 / IWL12 / IWL15
PHASE 6 Series 11 / 12 120v 60Hz
Supplementary manual to be used
in conjunction with
GWL03 Service Manual – 426348
(including a complete new set of
DETAILED FAULT CODES)**



FISHER & PAYKEL**ELECTRONIC WASHING MACHINE- MODELS
GWL11****IWL12****IWL15****plus fault codes for GWL03, GWL08, GWL10**

- November 2002: Repaginated (simplified page numbers) and alterations to sections 12 and 13.7
- March 2003: Added new fault code (66), user warnings and diagnostics table (16.3).
- May 2004: Added new model variant (IWL12) throughout relevant sections of manual.
- October 2005: Added new model variant (IWL15) throughout relevant sections of manual.

Fisher & Paykel Appliances
 78 Springs Road, East Tamaki,
 Auckland, New Zealand
 PO Box 58-732, Greenmount,
 Auckland, New Zealand
 Phone 00 64 9 273 0640,
 Fax 00 64 9 273 0649

Fisher & Paykel Appliances Inc.
 27 Hubble, Irvine
 California 92618
 USA
 Phone 1-888-9FNP-USA or
 (1-888-936-7872),
 Fax 949-790-8911

CONTENTS

12. WHAT PHASE, SIZE & MODEL IS YOUR SMARTDRIVE ?	4
13. SPECIFICATIONS	5
13.1 Finish	5
13.2 Dimensions	5
13.3 Maximum Capacity (Full Load) (AS 2040)	5
13.4 Water consumption per fill with clothes load using the Bern Clothes Washer Study	5
13.5 Water fill temperature (Approximate Factory Settings)	6
13.6 Wash Motor	6
13.7 Pump Motor 120V AC 60Hz (SELNI)	6
13.8 Water Valves	6
13.9 Thermistor	6
13.10 Basket Speed	6
13.11 Water Conservation Rating	6
13.12 Fabric Softener Dispenser	7
13.13 Electric Supply	7
13.14 Use and Care Compact Disc	7
13.15 Diverter Valve	7
13.16 Lid Lock	7
14. INTRODUCTION	8
14.1 Electronics	8
14.2 Stand by mode	8
14.3 Water Temperature Sensing	8
14.4 Water Valves	9
14.5 Stator	9
14.6 Pump	10
14.7 Lid-Lock	11
15. SIZE SETTING MODE FOR SERIES GWL11 / IWL12 / IWL15	12
15.1 Size setting – GW	12
15.2 Size Setting - IW	13
16. DIAGNOSTIC MODE	13
16.1 GW (Ecosmart)	13
16.2 IW (Intuitive)	14
16.3 SmartDrive Diagnostic Table - GW Only	15
16.4 User Warnings - GW	15
16.5 Data Display - IW	20
16.6 Drain Pump Test - GW & IW	21
16.7 Water Valve Test - GW & IW	22
16.8 Restart Feature – GW	22
16.9 Recycle Feature – GW	24
17. WIRING DIAGRAM	26
18. READINGS FROM MODULE	27
Pump/Motor	27
RPS	27
Display	27
Therm	27
Lid Lock / OOB	27
Diverter Valve	27
19. DETAILED FAULT CODES	28
FAULT DESCRIPTIONS	29

12. WHAT PHASE, SIZE & MODEL IS YOUR SMARTDRIVE ?

PHASE	YEAR	FRONT PANEL COLOURS	MODEL NUMBERS	MOTOR CONTROLLER	COMPONENTS	MODEL TYPES
PHASE 6 Series 11 (GW)	2002	Pale blue panel, blue & white buttons.	GWL11	Brown, aircooled	Inlet valves 24v 64 ohms.	ecosmart (recirc),
Series 12 (IW Eco)	2004	Opaque green panel with white raised buttons and LCD screen	IWL12	GW & IW have a thermistor in the mixing chamber.	Stator 16 ohms per winding.	Intuitive eco (recirc)
	2005	White panel with blue raised buttons and LCD screen	IWL15		Lid lock 73 ohms Selni pump 7 ohms. (all @ 20°C) 68 °F	

DISPLAY TYPE	IDENTIFIER
US 120V	Green background favourite, permanent press wool washables, softener rinse
IW Intuitive	White with LCD display,

SIZE	CAPACITY	DIMENSIONS
Large	(8 kg) 17.6lb	650 x 650 x (1020 – 1060 h) 25 ½ in. x 25 ½ in x (40 in – 41.¾in h)

Note: Phase 6 machines are a maximum of 1.5 inches (lid to floor) higher than phases 4 and 5.

13. SPECIFICATIONS

13.1 Finish

Cabinet Pre-paint (Polyester)
 Touch-Up Paint: White #503086
 Lid ABS Co-injected, one piece
 Console ABS with ABS insert for display control
 Inner bowl stainless steel grade 430T
 Outer bowl Polypropylene
 Agitator Polypropylene
 Top Deck Polypropylene

13.2 Dimensions

GWL11 / IWL12 / IWL15

Height to lid

Open	(1410 mm – 1440 mm)	55.5 in – 56.6 in
Closed	(950 mm – 980 mm)	37.4 in – 38.5 in
Height to console	(1010 mm – 1050 mm)	39.7 in – 41.3 in
Width	(650 mm)	25.5 in
Depth	(650 mm)	25.5 in

Note: Exact height of the SmartDrive is dependent on how far the feet are inserted into the base of the machine.

“L” models

Inlet hose length	(1200 mm) 47.2 in
Weight:	
Packed	(57.5 kg) 126.5 lb
Unpacked	(51.0 kg) 112 lb

13.3 Maximum Capacity (Full Load) (AS 2040)

Dry Weight (8kg) 17.6 lb

13.4 Water consumption per fill with clothes load using the Bern Clothes Washer Study

Load Size (lb)	Total H2O gal
1	9.4
3	18.9
5	24.5
7	24.6
9	29.2
11	34.9
13	34.6
15	34.3

13.5 Water fill temperature (Approximate Factory Settings)

	GW / IW
Hot	(60°C) 140° F
Hot / Warm	(50°C) 122° F
Warm	(40°C) 104° F
Warm / Cold	(35°C) 95° F
Cold Plus	(20°C) 68° F
Cold	Supply temperature

Recommended hot water inlet temperature 65°C (Max) 149°F

13.6 Wash Motor

Electronically commutated direct drive 3 Phase brushless DC Motor

Motor Resistance per Phase 16 ohms @ (20°C) 68°F

13.7 Pump Motor 120V AC 60Hz (SELNI)

Thermal cut-out fitted

Flow Rate (24 litres per minute) 6.3 gal / min

Pump motor resistance 7 ohms @ (20°C) 68°F

13.8 Water Valves

24 Volts DC

Digital Valve Resistance 64 ohms @ (20°C) 68°F
Flow Rate (10 litres per min) 2.6 gal/min

Proportional Valve Resistance 64 ohms @ (20°C) 68°F
Flow Rate (16 litres per min) 4.2 gal/min

Operating pressures Maximum 1034 kPa (150 PSI) 1034 kPa
Minimum 20 kPa (5 PSI) 34 kPa

Low flow can affect the digital valve (Hot) and create seating problems with the seal.

13.9 Thermistor

NTC-type temperature sensor Resistance 10,000 ohms @ (25°C) 77°F

13.10 Basket Speed

Fast Spin 1,000 RPM

Medium Spin 700 RPM

Slow 300 RPM

Stir Speed 25 RPM

13.11 Water Conservation Rating

GWL11 - AAA

IWL12 - AAAA

IWL15 - AAAA

13.12 Fabric Softener Dispenser

Dosage 75cc

13.13 Electric Supply

Operating Voltage 110/120V AC 60Hz

Maximum Current 7.0 amps

13.14 Use and Care Compact Disc

PN 420350 Compact Disk GWL11-IWL12 US

USA Replaces video on GWL 10

PN 420353 Compact Disk IWL15

13.15 Diverter Valve

Resistances 0.7K Ω to 2.5K Ω

13.16 Lid Lock

PN 420036P

Resistance range 73 ohms +/- 5 ohms

PN 420429

Resistance range 63 ohms +/- 10% @ 20°C (68°F)

Normally low voltage, potentially 230V if harness is grounded on the cabinet!

14. INTRODUCTION

MODEL: GWL11 Ecosmart / IWL12 - IWL15 Intuitive Eco

This Service Supplement contains information on the Product Specifications, Diagnostic Mode and the Detailed Fault Codes for Phases 4, 5 and 6, being Series 8, 10 and Series 11 / 12 machines respectively.

14.1 Electronics

The electronics for Series 11 / 12 are air-cooled in the same way as the Phase 5 (series 10) machine. This has changed from being water cooled as in earlier models. This has been made possible by changes to the stator winding which allows a lower current through the electronics and the use of the latest low loss, semi-conductor-switching device.

Electronic modules are **not inter-changeable** between models. The different modules for the different models can be identified by their colour. **L03** (green), **L08** phase 4 modules (yellow) and **L10**, phase 5 GW modules are grey. The new **L11/L12/L15**, phase 6 modules, GW are coloured brown.

GW/IW p/n 420094,



**Motor controller
&
GW display**



GW & IW Motor controller



**Motor controller
&
IW display**

It is important not to mix the different coloured modules as they are not compatible and the washing machine will not work.

The latest module is similar to the series 10 module. The difference is that the terminals are pushed on sideways at the top of the module.

The Series 11 / 12 module now has a 7 position connection for the display and a 4 position connection for the Lid Lock / OOB.

14.2 Stand by mode

If a Series 11 / 12 machine has not received any instructions for 10 to 15 minutes after being switched on at the power point or after completing the cycle, it will automatically go into a low power Stand By mode, same as the Series 10 SmartDrive. Before entering the Diagnostic or Option Adjustment modes, the machine must be taken out of the Stand By mode. To do this, the power button will have to be pressed on and off or the machine turned off and on at the power point.

14.3 Water Temperature Sensing

The thermistor for sensing water temperature in the ecosmart is located in the inlet chamber and is available as a separate spare part under part number 479164P. See specifications for the temperature / resistance readings.

14.4 Water Valves

The Series 11 / 12 machines use different water valves to the Series 8 and 10 machines. The valves are essentially the same (24 volts) but now have **US standard threads** which are **not interchangeable** with previous models of SmartDrive washing machines, especially the early LO3's which are 12V with posilock connectors.

It is suggested when replacing a valve to use the same part number or superseded number, leaking may occur if unlike threads are attached to inlet hoses.

The terminals are the "RAST 2.5" system. Extra care must be taken to ensure these connections are plugged in squarely to avoid damage to the terminals.

There are two types of coil orientations possible on these valves, however the fittings are identical. When removing the harness plug from the valve, a small retaining clip must be released. The series 8 and 10 machines have these valves with the retaining clip located on the solenoid behind the plug. Harness removal is a blind action.

14.5 Stator

The stator resistance of the Phase 6 is 16 ohms per phase, same as the previous phase 5, which changed to allow for a lower current through the electronics. This stator is **not interchangeable** with the previous models and can be identified by smaller terminal connections. The rotor has not changed and can be used for all models of SmartDrive.

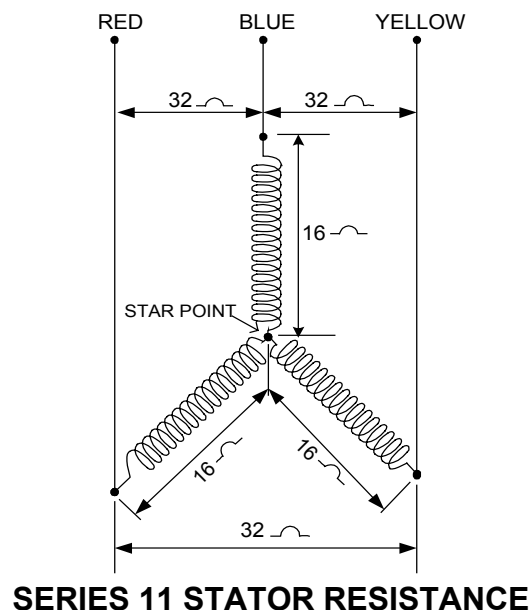

14.6 Pump

The pump now uses a vortex impellor, which reduces the operating sound levels at the end of the drain cycle. The new pump is a dedicated 110V 60Hz Selni pump. The way the pump is controlled has changed. During the drain cycle the pump is stopped and started quickly every 10 / 15 seconds.

The pulsing on and off of the drain pump only occurs when the basket is floated.

Changing the factory setting (GW Machine only):

Pulsing can be turned off if a higher head height is required (**7 feet max**), however the possibility of pump blockage and Suds lock increases, which in turn affects the required head height.

Enter "**SIZE SETTING**" mode (**TEMP UP and POWER**) this should be familiar when changing modules and or displays.

The **REGULAR** cycle button toggles between having this feature disabled or enabled.

The **REG LED** shows the current status, when the **LED is on** in this mode the **pulsing is disabled**. No other settings will be affected by this change and the setting will be saved in eeprom. Power off in the same manner as with size setting to retain the setting.

If dual pumps were to be fitted, this feature should be used where the intermediate head height is above 5 feet. The pulsing function is most effective in standard head height situations (up to 6 feet).

Note:

If the pump has blocked/jammed and the thermal overload has gone open circuit, just remove the blockage from the pump. The module and the pump should still be okay. If the pump windings are **water damaged**, the pump will quickly overheat and cut off again. The pump must be replaced in this case. (If the pump shorted to earth, it is possible that the module could short out on series 10 machines). Series 11 should not have this problem. The pump is not powered through the motor controller as with the phase 5 products. Series 11 phase 6 machines do not utilise the pump to dump energy. This change also reduces the potential for failure.

It is important to check the pump windings thoroughly for water damage. It is possible for the resistance of a water-damaged pump to be normal, however the inductance of the pump can change causing it to overheat and cut out. There are new fault codes in the system that now relate to the pump circuit and its extended function.

14.7 Lid-Lock

On the Series 11 /12 SmartDrive there is now a lid lock. During the spin and drain out part of the cycle prior to spray rinsing, the lid will lock down until the completion of the spin. Once the spin has completed, the lock will release and the lid can be opened. The Lid Lock LED will illuminate when locked.

A lock icon will be displayed on the IW model when the lid lock is activated.

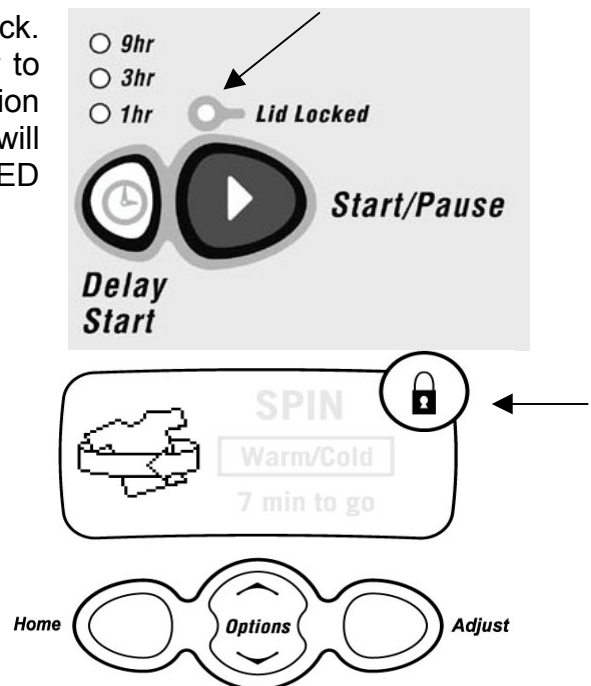

If the lid lock fails in the closed position the removal process is as follows:

The locked lid can be lifted on the sides enough to allow the lid buffers to be removed. This will allow the screws holding down the top deck to be unscrewed. The top deck can then be lifted up, removing the lid lock screw will allow the lid lock housing to be replaced. Un-clip the clear cap from the housing and disconnect the Rast connection. Clip the new housing in and re-assemble.

If the harness is damaged, replacing it requires the following method.

Remove the lid from the top deck assembly. The Console will then need to be removed to access the wiring connection to the motor controller if the wiring loom is replaced. This harness is also part of the harness to the OOB switch and the motor controller will need to be lifted to remove and replace it. Remember to secure the wire into the retainers under the top deck, or damage may occur during operation.

Note:

If the power supply is cut during the spin cycle, the machine will keep the lid locked until the rotor has ceased to turn (3 to 15 secs). Only then will it release the lock, the motor is acting like a generator and allows the lock to stay energised under the baskets inertia via the motor controller. In a brown out situation the machine will restart at the start of whatever cycle it was doing and continue the wash. The lid lock would then be reactivated if it happened to be on a spin cycle.

15. SIZE SETTING MODE FOR SERIES GWL11 / IWL12 / IWL15

15.1 Size setting – GW

The difference between the GW Series 11 and previous GW machines is the position of the **Power** button. The sequence for sizing the modules is the same.

It is important to set the size switch setting into the Motor Controller's memory whenever a replacement Motor Controller and or IW Display Module is fitted to SmartDrive. Failure to do this will result in SmartDrive faulting with fault code 9 (Size switch error).

Accessing size setting mode is the best way to check the size for GW. The size setting of SmartDrive may be checked in Diagnostic mode for all phases.

To set the size switch turn the power on at the power point and off at the console. Press and hold the **TEMPERATURE UP** button then press the **POWER** button. SmartDrive will give 4 short beeps and the pattern of LEDs will change.

- Press **SPIN SPEED UP** button, the **SPIN HOLD** LED is on for (8.0kg) **17.6lb** (650mm wide). 25.5 in
- Press **POWER** to exit this mode.

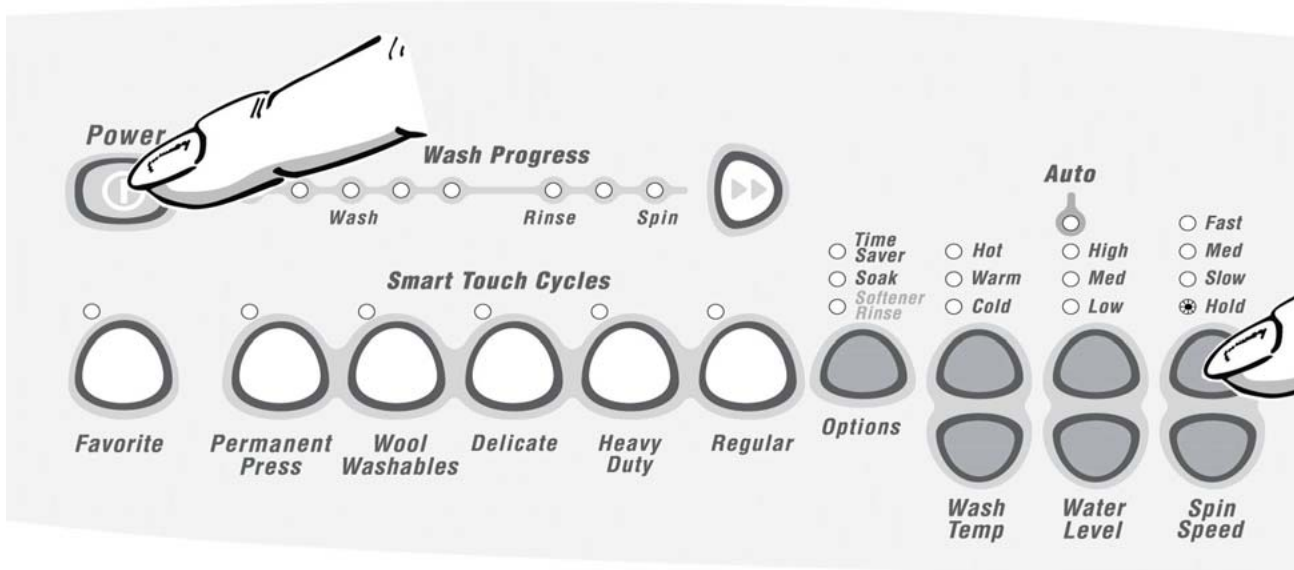

If the size setting is wrong SmartDrive will have the following settings incorrect: -

- The Auto Water Levels chosen by SmartDrive may be wrong.
- The High Water Level may be wrong by as much as 1.5 in.
- The flow rate for inlet water, normally (3 litres or 0.8 gal per minute), may be set incorrectly.
- The wash profile controls the strength of the agitator. This could result in poor wash performance or splash over.
- Water saver settings.

15.2 Size Setting - IW

To set the size, turn the power on at the power point and off at the console. Press and hold the **FABRIC CARE** button, then press the **POWER** button. This will present a set of options in the LCD screen.

The LCD screen has within it a number of options. Push the **Adjust** button to highlight 650mm (L). Pushing the **POWER** button will lock the "size" into the module's memory.

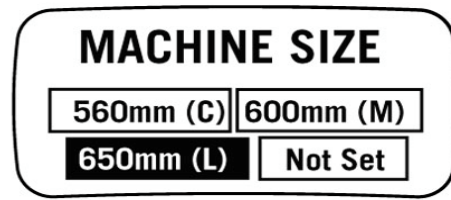

16. DIAGNOSTIC MODE

16.1 GW (Ecosmart)

Turn the power on at the power point but off at the machine. Press and hold the **WASH TEMP DOWN** button and then the **POWER** button until the machine gives 2 short beeps and lights up. Release buttons when the beeps indicate diagnostic mode has been entered.

Note: The power button is relocated to the left of the panel but central to the console, not on the right hand side as with all previous GW SmartDrive machines.

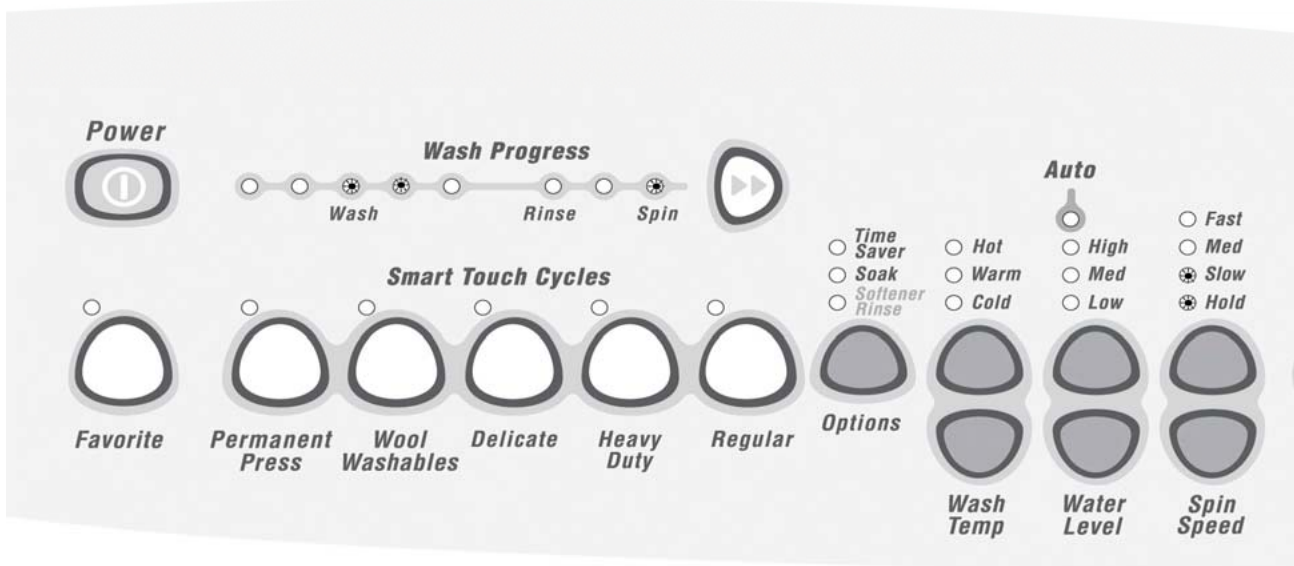

Last fault can be found by pressing the **SPIN SPEED UP** button three times. The **HOLD** and **SLOW** lights should be illuminated. Binary can then be read from the wash progress lights. Fault code 49 is shown above, $32 + 16 + 1 = 49$ which is a cold water valve fault.

Binary code is read from the **Wash Progress** lights.

128	64	32	16	8	4	2	1
0	0	0	0	0	0	0	0

16.2 IW (Intuitive)

The **DIAGNOSTIC MODE** in the **IW** (Intuitive) incorporates both tests for the drain pump and the water valves, and also the data display mode (see section 16.5).

To enter the **DIAGNOSTIC MODE**, turn the power on at the power point and off at the console. Press and hold the **LIFECYCLES** button and then the **POWER** button.

The machine will give 2 short beeps and the LCD screen will go blank. Then press **OPTIONS** for data retrieval.

Note: Make sure that the buttons are released after the beeps, or the machine will turn itself out of the diagnostic mode.

16.3 SmartDrive Diagnostic Table - GW Only

To use this table, firstly enter Diagnostic Mode. The different levels of information can be extracted by using the Spin Speed up and down buttons.

Diagnostic Mode	Spin Speed LEDs				Diagnostic Info Displayed
	Fast	Med	Slow	Hold	
0	OFF	OFF	OFF	OFF	Last User Warning Number
1	OFF	OFF	OFF	ON	Last User Warning Cycle Position
2	OFF	OFF	ON	OFF	HVDC setting (used by auto WL sense agitate)
3	OFF	OFF	ON	ON	Fault Code at last fault (if within the last 8 cycles)
4	OFF	ON	OFF	OFF	OOB status
5	OFF	ON	OFF	ON	Cycle count at last fault (low byte)
6	OFF	ON	ON	OFF	Cycle count at last fault (high byte)
7	OFF	ON	ON	ON	Cycle position at last fault
8	ON	OFF	OFF	OFF	Water Temp (deg C)
9	ON	OFF	OFF	ON	Cycle count (low byte)
10	ON	OFF	ON	OFF	Cycle count (high byte)
11	ON	OFF	ON	ON	Motor speed (rpm/10)
12	ON	ON	OFF	OFF	Water Level
13	ON	ON	OFF	ON	EEPROM version number
14	ON	ON	ON	OFF	Software Version number
15	ON	ON	ON	ON	(F&P development use only)

16.4 User Warnings - GW

There are a number of warnings, which are generally caused by the user or poor installation. The user generally can correct these warnings. SmartDrive signals user warnings by flashing LEDs and a rippling set of 5 beeps repeated every 6 seconds. This is the same tone that is heard when SmartDrive is first plugged into the mains power. Some warnings are indicated by the wash progress LEDs flashing and no user warning tone, (Restart or Recycle mode). Most of this information is available to the user in the 'Use and Care Manual'

16.4.1 Insufficient Hot Water (Hot Water LED flashing)

This warning is indicated by the hot water LED flashing. SmartDrive will also be making a rippling set of 5 beeps repeated every 6 seconds. The hot water is not connected or the water temperature is too low. NB. This warning mode does not cause the product to PAUSE.

1. Check that the hot water is connected and that the tap is turned on. If your product is set for 'controlled cold' hot water may still be required for a cold wash.
2. Check that the water temperature is not too low. The water temperature may need to be 60°C (140°F) for a hot wash.
3. Check that the hot water inlet is not connected to the cold water supply.
4. Check that the filter on the hot inlet hose is not blocked.
5. Motor Controller.(Phase 1 to 4). Thermistor (Phase 5). The temperature sensor has failed. Replace motor controller.(Phase 1 to 4) Check the resistance of the thermistor. Resistance is 12.5k ohms at 20°C (68°F). Replace if faulty. (Phase 5).
6. Check the size is set correctly.

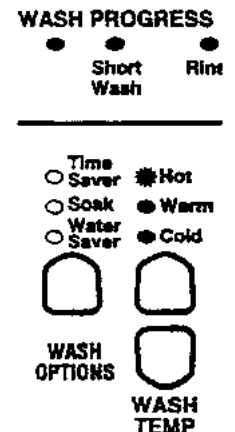

NB. It is possible to get this warning when washing with cold water if the cold wash temperature is set at 20°C (68°F) or more. Wash temperatures may be adjusted, see section 7.1.

16.4.2 Insufficient Cold Water (Cold Water LED flashing)

This warning is indicated by the cold water LED flashing. SmartDrive will also be making a rippling set of 5 beeps repeated every 6 seconds and the product will be paused. The cold water is not connected or the flow rate is too low.

1. Check that the cold water is connected and that the tap is turned on.
2. Check that the flow rate is not too low. The product requires a minimum flow rate of 3 litres per minute. Check that the filter on the cold inlet hose is not blocked. If the installation has a flow rate below 5 litres per minute the flow may be improved by using large bore inlet hoses p.n. 426123.
3. Taps may be connected the wrong way round.
4. Cold water temperature exceeds 35°C (95°F). NB. Phase 2-4. If cold water temperature exceeds 40°C (140°F) high purge motor controllers are available. Contact your Technical Representative.
5. **Phase 1-4.** Motor Controller. The temperature sensor has failed. Replace motor controller.
6. **Phase 5.** Thermistor. Check the resistance of the thermistor. Resistance is 12.5k ohms at 20°C (68°F). Replace if faulty.
7. Check the size is set correctly.

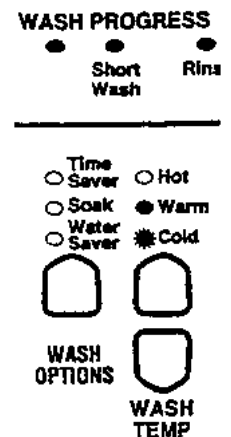

16.4.3 No Water (Both Hot and Cold Water LEDs flashing)

This warning is indicated by the cold and hot water LEDs flashing. SmartDrive will also be making a rippling set of 5 beeps repeated every 6 seconds and the product will be paused.

1. Check that the taps are turned on.
2. Check that the inlet hoses are connected.
3. Check that the flow rate is not too low. The product requires a minimum flow rate of 3 litres per minute. Check that the filters on the inlet hose are not blocked. If the flow rate is always low then fit large bore inlet hoses.
4. Check that the hot water is connected and that the tap is turned on. If your product is set for 'controlled cold' hot water may still be required for a cold wash.
5. Siphoning. Check the drain hose is not installed too low and is siphoning.
6. Check the size is set correctly.

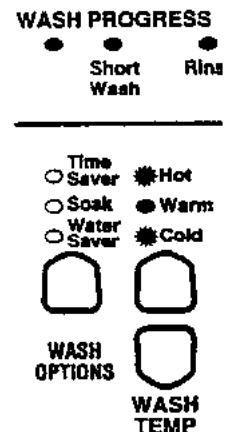

16.4.4 Overloaded Product (High Water LED flashing)

This warning is indicated by the high water LED flashing. SmartDrive will also be making a rippling set of 5 beeps repeated every 6 seconds and the product will be paused. The product is overloaded.

1. Check that the product is not overloaded. This is more likely on a smaller size product. Also it may be that the user has selected the wrong water level this is more likely to be a LW or MW, which only has 3 water levels.
2. Check that the rotating bowl assembly is not jammed to the agitator with any foreign object that may be caught under the agitator skirt.
3. Check that the clutch teeth are not locked together with dirt, detergent or lint. Check that the teeth are not broken.

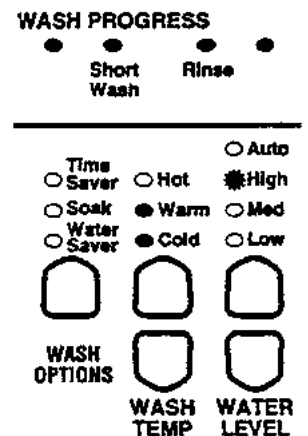

16.4.5 Out of Balance (First Rinse or Final Spin and Current Spin Speed LED is flashing)

This warning is indicated by a rinse or spin LED and the current spin speed LED flashing. SmartDrive will also be making a rippling set of 5 beeps repeated every 6 seconds and the product will be paused.

1. Generally this can be caused by a large load. SmartDrive will normally manage to redistribute the load and spin. Under exceptional circumstances the user may need to redistribute the wash load manually once the bowl is stationary.
2. Check that SmartDrive is correctly installed, is level and does not wobble.
3. Check the bias spring is fitted between the wrapper and the outer bowl.
4. Check the OOB lever, switch and bracket.
5. Check the switch operates correctly with a multimeter. Resistance should be less than 2 ohms.
6. Check the suspension is not catching or bouncy.
7. Check both balance rings on the inner bowl contain water.
8. The Motor Controller, (Display for Phase 1) should only be replaced if fault code 43.

16.4.6 Suds (First Rinse LED is flashing or Final Spin LED is flashing)

This warning is indicated by a rinse or spin LED flashing. SmartDrive will also be making a 'rippling sound of 5 beeps repeating every 6 seconds' and the product will be paused. Too much Detergent has been used and SmartDrive has a suds build up.

1. This is generally caused by too much detergent. Wait for suds to dissolve then rinse clothes using a deep rinse.
2. Check that the pump is not partially blocked, or that the drain hose is not kinked.

16.4.7 User Warnings – IW

The Intuitive Eco is capable of diagnosing its own problems and if it has a problem it will beep and display a message telling the customer what is wrong. If it is a problem that the customer is capable of solving it will give a musical series of beeps every 5 seconds (the same sound the machine makes when it is turned on at the wall) and will display one of the following messages.

Note: The musical series of beeps is the same sound the washer makes when its turned on at the wall.

IF YOUR INTUITIVE BEEPS FOR HELP

My load is OUT OF BALANCE
Wash load is out of balance. Ensure the machine is stationary and manually redistribute the load. Check machine is level.
I am not getting any HOT WATER
Hot water supply is not hot enough to maintain the wash temperature you have selected. Select a lower wash temperature. Inlet hose screens may be blocked. There may be a kink in the hose. Hot tap has not been turned on. Inlet hoses connected to the wrong taps.
I am not getting any COLD WATER
Cold tap has not been turned on. Inlet hose screens may be blocked. There may be a kink in the hose. Inlet hoses connected to the wrong taps. Cold water temperature exceeds recommended limits. The flow rate of the supply water is too slow.
I am not getting any WATER
The taps have not been turned on. Inlet hose screens may be blocked. The hoses may be kinked. The drain hose is too low or the drain hose is pushed into the standpipe too far and the water is siphoning out of the machine. The flow rate of the supply water is too slow.
I am OVERLOADED
The machine is overloaded and can not agitate. Ensure the machine is stationary. Remove items until the remaining ones can move freely, or select a higher water level. Check the machine is not syphoning.
I have TOO MANY SUDS
The machine has a suds build-up. (Too much detergent may have been used for the amount of soil in the load).

Wait for suds to dissolve (about 20 minutes).
Rinse clothes using a deep rinse.

I can't LOCK THE LID

Make sure the lid is closed.
Press START PAUSE.
If the symptom persists call your Fisher and Paykel Dealer or Authorised Service Centre.

16.4.8 Demonstration Mode (GW & IW) - All LEDs flashing in patterns

These features are designed for in store demonstration purposes. SmartDrive can draw attention to itself with a selection of flashing LEDs. In this mode SmartDrive cannot be started.

GW: To Select DEMONSTRATION MODE press and hold the **ADVANCE** button, then press the **POWER** button.

During the DEMONSTRATION display the LEDs will alternate between all on, LEDs flashing, and all LEDs off. To return SmartDrive to normal operation, the mains supply must be switched off. Some Phase 1-3 displays may inadvertently go into this mode if affected by condensation.

IW: Press **START/PAUSE** and hold down then press **POWER**

The Demo Mode scrolls through a series of text, advertising the various features of the product, while flashing the LEDs. The backlighting of the LCD display also flashes for the first few seconds to attract attention.

It then shows several samples of the animations used during the wash, before repeating.

If any of the keys are pressed, Demo Mode stops, and the displays changes to normal "on" mode, to allow the user to navigate around the menus, as they would normally if using the product. In this mode the machine will not allow a normal cycle to start (it will raspberry if Start/Pause is pushed).

After 30 seconds without a key press, the display automatically reverts back to Demo Mode again.

To exit the Demo Mode the power has to be turned off at the wall and then back on.



16.5 Data Display - IW

To enter the **DATA DISPLAY** screens, push the **LIFECYCLES** button again. This will enable the out of balance switch to be tested, as well as giving access to the Detailed Fault Codes and User Warning Faults. One of three displays will appear in the screen. Use the buttons on the bottom of the display screen to toggle between these displays. Options, up or down.

The **Warning Status** screen will display the last **USER WARNING FAULT** that occurred and will show at what part of the cycle it occurred.

The User Warning Faults are as follows:

- No Taps
- Overloaded
- Out Of Balance
- Over Suds or water still in the machine during spin
- No Hot Water
- No Cold Water
- Agitate Overloaded

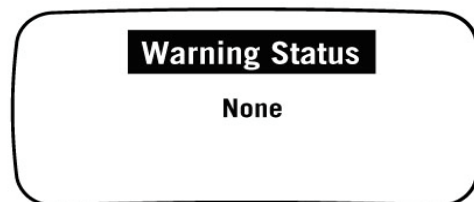

The **Machine Status** screen displays the status of the diverter and the out of balance switch. It also displays the size setting of the machine, and the thermistor temperature.

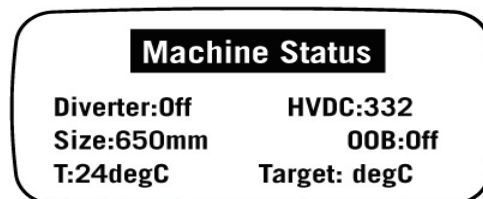

HVDC is for on line testing in the factory.
Target temp is the temperature selected.
T is the actual temp of the inlet chamber water.

The **Fault Status** screen will display a code for the last fault that has occurred in the machine. It will also display how many cycles ago that the fault occurred, and at what part of the cycle.

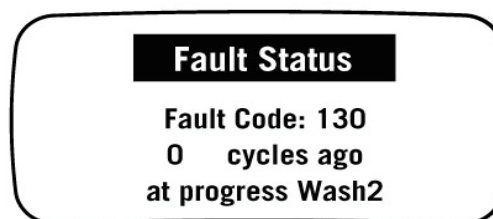

See Detailed Fault Codes for servicing tips.



The fault code number can now be checked in the detail fault codes, to ascertain what repairs may be necessary.

16.6 Drain Pump Test - GW & IW

GW

The **Regular** button activates the pump when in diagnostic mode. Enter diagnostics using the same sequence as previous phases. The **Power** button is in the middle of the console, not on the right hand side as with series 8 and 10 machines!

For testing the pump, the **Regular** button (ecosmart) will activate the regular light, which in turn activates the pump. Pressing the button activates the pump. Pressing the button again de-activates the pump.

IW

The **Fabric Care** button turns the drain pump on or off when in diagnostic mode.

Note: This feature can be helpful if the bowl is still full of water.

16.7 Water Valve Test - GW & IW

GW

The water valves are activated in diagnostic mode. Pressing the **Temp up** button for **Hot valve** (digital) and **Temp down** button for **Cold valve** (proportional) as with previous models.

Pressing each button once will activate the valve. To de-activate the valve, press the same button again. **Caution: Do not leave the machine unattended when either or both valves are operating.** This is also good to use when installing machines. It takes the shock out of the fittings and seals and allows checks for leaks on the inlet hoses both machine end and tap end.

IW

The water valves are activated when in diagnostic mode. Pressing the **How Dirty** down button will turn the Cold water valve on. Pressing the **How Dirty** up button will turn the hot water valve on. You need to hold the buttons down to keep the water entering the machine. This is also good to use when installing machines as it takes the shock out of the fittings and seals and allows checking for leaks on the inlet hoses, both machine end and tap or super-tub end.

16.8 Restart Feature – GW

For GW Restart setting, enter **Diagnostics Mode** with the power off at the machine but on at the wall outlet. Press and hold the **Wash Temp down** button and then press the **Power** button. 2 beeps will be heard when this mode has been entered successfully.

An illuminated LED on **low water level** will indicate the **Restart feature is activated**. Using the low water level button this feature can be disabled for servicing and quick fault diagnosis, or enabled when returning to the customer.

To make sure the phase 6 module retains the restart feature (when it has been disabled for service reasons), press and hold the **Advance button** down at the same time when pressing the **Water level** down button. A long beep will acknowledge the setting has been retained in EE prom. **Power** off to retain selection as with size switching.

When the machine is first turned on:

1. If **none** of the **5 left most green wash progress LED's** are **on**, the restart feature is **on**.
2. If all **5 of the left most green wash progress LED's** **flash**, the restart feature is **off** and SmartDrive will not restart automatically if a minor fault occurs during normal usage.

With the RESTART feature on:

1. If a fault occurs in the machine, the diagnostic system will detect it. However, instead of displaying a fault code immediately, the machine will try to RESTART.
2. If the fault was only of a temporary nature, the machine will restart and finish the cycle.
3. If there is a continuous fault the machine will try to RESTART a number of times. This process could take up to 8 minutes depending on the type of fault. After this, if the machine still cannot restart, the fault code is displayed and the machine will beep continuously.

NOTE - This feature is designed as a service aid only and should be left ON in the customer's home. To return to normal operation, and to reset the RESTART feature to the factory setting, switch the machine off at the wall or disconnect from the mains supply.

16.8.1 Restart Feature – IW

IW Restart setting can be accessed when in diagnostic mode, pressing the **Options** button will bring up the **Control Option** screen. The LCD screen will display the following:

The machine leaves the factory with the RESTART set to the ON position (as shown here), which is indicated in the screen by the word RESTART highlighted. To turn the RESTART feature OFF, push the **Home** button. This will remove the highlight from the word RESTART. When the machine is being serviced, it is more convenient to turn the RESTART feature OFF. This will allow any fault in the system to show up immediately.

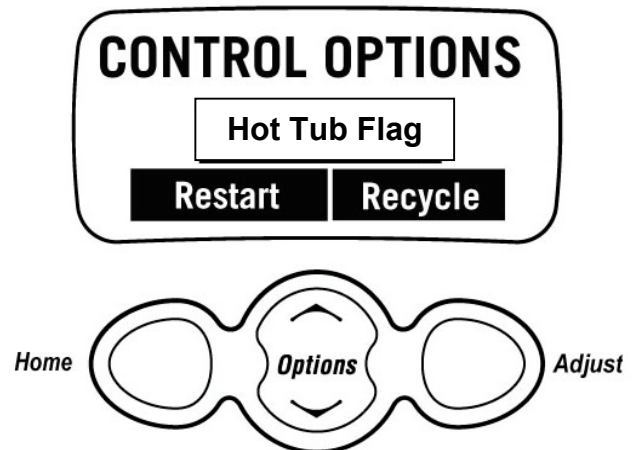

With the RESTART feature on:

1. If a fault occurs in the machine, the diagnostic system will detect it. However, instead of displaying a fault code immediately, the machine will try to RESTART.
2. If the fault was only of temporary nature, the machine will restart and finish the cycle.
3. If there is a continuous fault the machine will try to RESTART a number of times. This process could take up to 8 minutes depending on the type of fault. After this, if the machine still cannot restart, the fault code is displayed and the machine will beep continuously.

Whether or not the RESTART feature is on is indicated during normal use of the machine as follows:

1. If none of the 5 green "**HOW DIRTY**" LED's are on, the RESTART feature is on.
2. If the 5 green "**HOW DIRTY**" LED's are flashing, the RESTART feature is off.

NOTE - This feature is designed as a service aid only and should be left ON in the customer's home. To return to normal operation, and to reset the RESTART feature to the factory setting, switch the machine off at the wall or disconnect from the mains supply.

16.9 Recycle Feature – GW

At the end of servicing, the machine may require an extended test where the machine can be left to complete a number of wash cycles. By turning on the RECYCLE feature the machine will continuously repeat the wash cycle until the RECYCLE feature is turned off.

To activate or deactivate the RECYCLE feature: Enter diagnostic mode, the WATER LEVEL UP button toggles this feature on and off. If the Medium Water Level LED is on the RECYCLE feature is on, if the Medium Water Level LED is off the RECYCLE feature is off.

Whether or not the RECYCLE feature is on is indicated during normal use of the machine as follows:

When the machine is first turned on:

1. If **none** of the **3 right most wash progress LED's** are **on**, the recycle feature is **off**.
2. If all 3 of the **right most wash progress LED's flash**, the recycle feature is **on** and SmartDrive will continuously recycle.

NOTE - This feature is designed as a service aid only and should be OFF in the customer's home. To return to normal operation, and to return the recycle feature to the factory setting, switch the machine off at the wall or disconnect from the mains supply.

16.9.1 Recycle Feature - IW

In the Control Option mode (as for setting the RESTART feature), pushing the **Adjust** button to highlight the word RECYCLE will toggle this feature on and off. At the end of servicing, the machine may require an extended test where the machine can be left to complete a number of wash cycles. By turning on the RECYCLE feature the machine will continuously repeat the wash cycle until the RECYCLE feature is turned off.

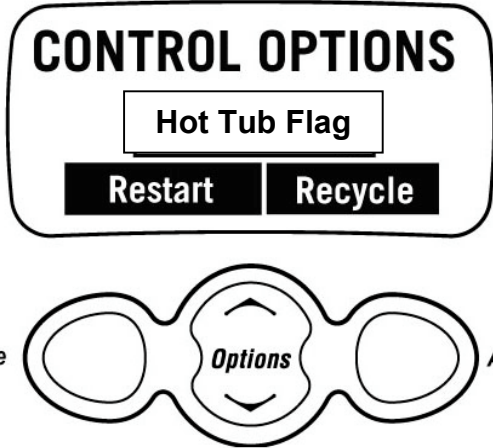
<p>Whether or not the RECYCLE feature is on is indicated during normal use of the machine as follows:</p> <p>When the machine is first turned on:</p> <ol style="list-style-type: none"> 1. If none of the Fabric Care LED's are on, the recycle feature is off. 2. If all of the Fabric Care LED's flash, the recycle feature is on. 	
---	--

NOTE - This feature is designed as a service aid only and should be OFF in the customer's home. To return to normal operation, and to return the recycle feature to the factory setting, switch the machine off at the wall or disconnect from the mains supply.

16.9.2 Hot Tub Flag – GW & IW

If the machine has been filled with the hot water valve utilised (ie. warm or hot fill) and has not had a cold rinse; the electronics will not allow the machine to spin up to its full speed of 1000 RPM. It will only allow the spin speed to reach 700 RPM.

To allow the machine to spin up to 1000 rpm, restart the machine at cold rinse and this will reset the Tub flag detecting.

GW

The **Softener Rinse** LED will be on when the **Diagnostic Mode** is selected if the spin speed is restricted to 700 rpm. To clear this flag press the **Wash Option** button below the **Softener Rinse** LED.

IW

To remove this flag, enter the Control Option mode and push the **Options Up** button to take the black shading out of the box **Hot Tub Flag**, or put the machine through a complete final rinse.

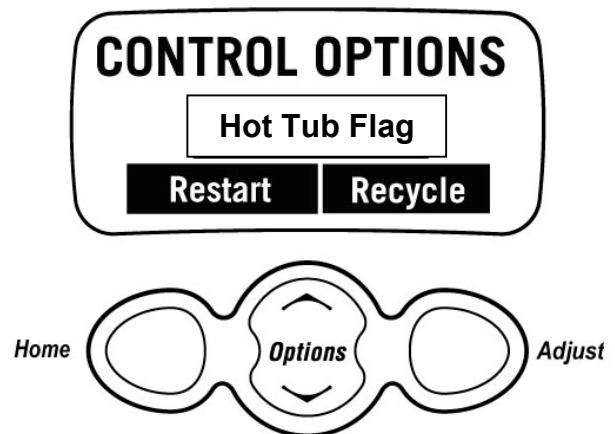

NOTE: The drain pump test, water valve test, restart, recycle and hot tub flag features can be accessed from any level in the diagnostic mode.

17. WIRING DIAGRAM

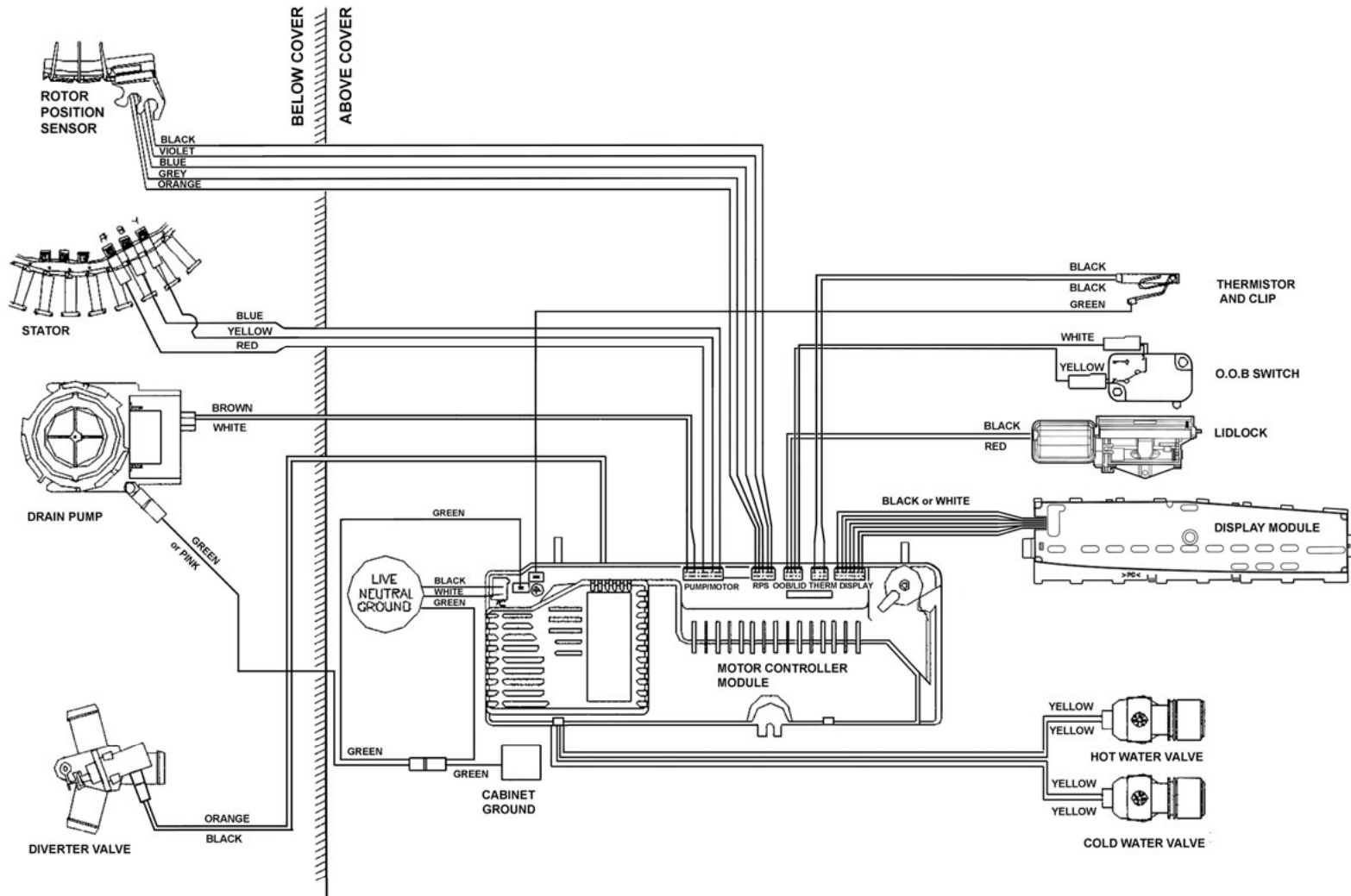

©Fisher & Paykel Appliances, 2004

18. READINGS FROM MODULE

Expected Readings on 120V Motor Controller

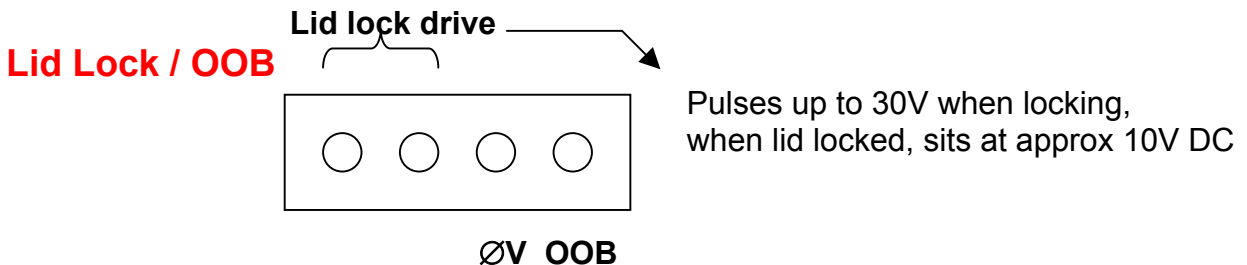
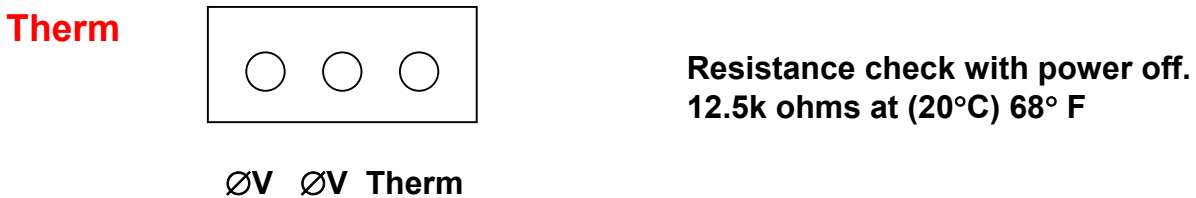
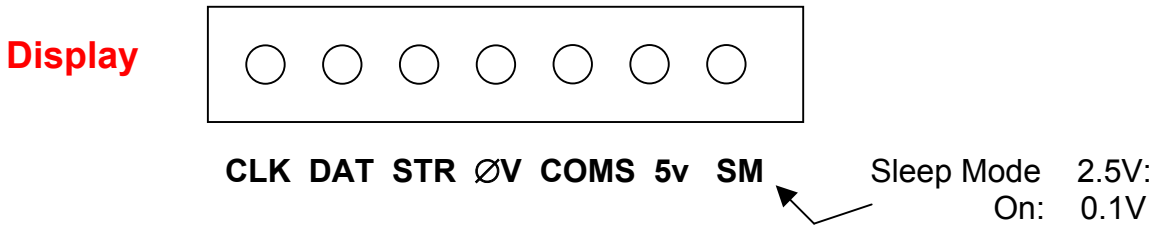
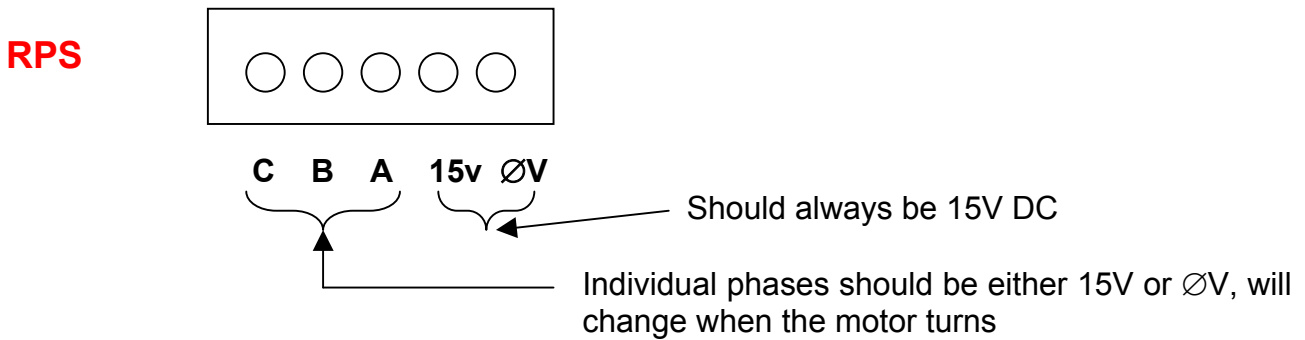
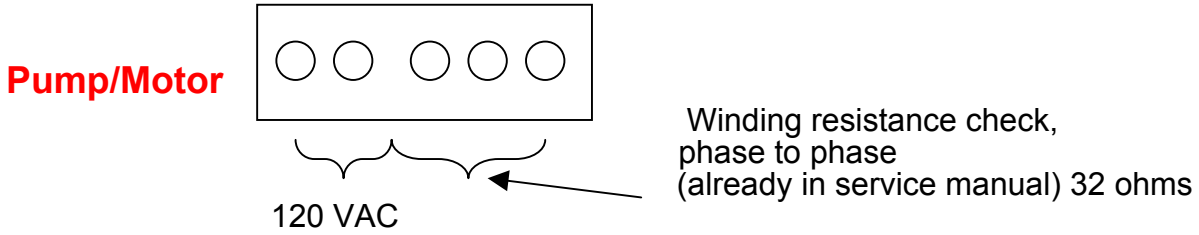

Diverter Valve

Approx 100 V AC when on, across the terminals, not strictly AC, rectified mains
Fluke meters read approx 100 V AC or 220 V DC (rms) depending on meter.

19. DETAILED FAULT CODES

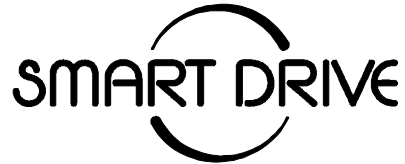

DETAILED FAULT CODES FOR MODELS

Phase 3	GWL03
Phase 4	GWL08
Phase 5	GWL10
Phase 5 IW	IWL10
Phase 6	GWL11
Phase 6 IW	IWL12 / IWL15

INTRODUCTION

The format for fault description in this booklet follows the Primary, Secondary, Tertiary and Quaternary fault source system. These sources have mostly been arranged in order of most likely source of fault, but in some cases the sequence has been modified to aid the servicing procedure.

It should be noted that the fault source **Pump System** includes the pump and drain hose assembly.

Fault code shows the last recorded fault. Always confirm fault.

FAULT DESCRIPTIONS

1. **(00000001) Phase 1 - Display Module Fault**
 Phase 2 to 6 - Motor Controller Module Fault
 The Motor Controller Module (Display for phase 1) has encountered an error when writing to an Eeprom address.
Primary Source: Motor Controller module. (Display Module for Phase 1)
Action: Replace Motor Controller module. (Display Module for Phase 1)

2. **(00000010) Phase 1 - Display Module Fault**
 Phase 2 to 4 - Motor Controller Module Fault
 An error has been encountered when trying to read the pressure sensor.
Primary Source: Motor Controller module. (Display Module for Phase 1)
Action: Replace Motor Controller module. (Display Module for Phase 1)

3. **(00000011) Phase 1 to 6 Motor Controller Module Fault**
 The Motor Controller Module has found a memory error.
Primary Source: Motor Controller module.
Action: Replace Motor Controller module.

4. **(00000100) Phase 1 - Communications Fault**
 The Motor Controller has had difficulty communicating with the Display Module
Primary Source: Motor Controller module.
Action: 1. Turn off at the wall and on again after 5 seconds and try again.
 2. If still faulty, replace the Motor Controller
 3. Replace Display Module. If the new Display Module corrects the fault, then refit the original Motor Controller.

5. **(00000101) Phase 1 - Communications Fault**
 The Display Module has had difficulty communicating with the Motor Controller.
Primary Source: Display Module.
Action: Turn off at the wall and on again after 5 seconds and try again.
 1. Check connections of the 12 way harness for bad contacts, corrosion etc.
 2. Check for moisture in the console area. Dry out if necessary
 2. If still faulty, replace the Display Module
 3. If still faulty, replace the Motor Controller. If the new Motor Controller corrects the fault, then refit the original Motor Controller.

6. **(00000110) Phase 1 – Display Module Fault**
 Phase 2 – 4 Motor Controller Module Fault
 The Motor Controller module (Display Module for Phase 1) has received an incorrect signal from the pressure sensor.
Primary Source: Motor Controller module. (Display Module for Phase 1)
Action: Replace Motor Controller module. (Display Module for Phase 1)

7. (00000111) Phase 1 to 6 - Display Module Fault

The Display module has found a memory fault.

Primary Source: Display Module.

Action: Replace Display module.

8. (00001000) Phase 1 - Display Module Fault

The Display micro has not been able to start up correctly.

Primary Source: Display Module.

Action: Turn off at the wall and on again after 5 seconds and try again. If still faulty replace the Display Module.

9. (00001001) Phase 1 to 6 Size Switch Error

The Display size switch setting does not match that stored in the memory.

Primary Source: Display Module Phase 1,2 & 3.

Action:

If the Display module for Phase 1, 2 or 3 has just been inserted into a console housing, then check that the two size switch plungers accurately locate onto the console housing. If this fault has appeared during normal operation of the machine, check for condensation damage, check the size switch or replace the Display module.

Secondary Source: Motor Controller module.

Action Phase 1, 2 &3:

If the Motor Controller module has been changed from one size machine to another, then the size switch settings in the memory will have to be reset. This can be done by entering and exiting the Option Adjustment mode. Push and hold START/PAUSE then push POWER button.

Action Phase 4 Series 8, Phase 5 Series 9 / 10 & Phase 6 Series 11:

Reselect the size of the machine by using the SIZE SETTING MODE. Push and hold the WATER TEMP UP button then press the POWER button. To select the size of the machine, push the temperature up button until the cold LED is on for 5kg machines, push the water level up button until the low water level LED is on for the 6kg machines, push the SPIN SPEED UP button until the hold LED is on for 7kg machines.

10. (00001010) Phase 1 to 6 Temperature Sensor (Thermistor) Error

The temperature sensor may be open circuit or the ambient temperature is below minus (10°C) 50° F. This fault is only applicable in the Intuitive Washer and the GW models.

Primary Source: Thermistor.

Action: Replace Thermistor.

11. (00001011) Phase 1 to 6 - Pressure Sensor Fault

While measuring the water level, the Motor Controller micro has detected a negative pressure. Reconnecting the pressure tube to the pressure sensor while the bowl has been partly filled with water may have caused this.

Primary Source: Pressure Tube.

Action:

- 1) Check bowl is fully pumped out. Remove pressure tube from pressure sensor, clear pressure tube of any water and reconnect tube.
- 2) If fault is still present, replace the Motor Controller module.(Display Module Phase 1)

12. (00001100) Phase 1 to 6 - Flood Protection Error

The Motor Controller module has found the water level to be above the flood level and tried to pump the excess water out. (Under extremely high flow rate conditions the machine may overflow during the "top-up" routine in agitate.) After pumping for 30 seconds, it has been unable to lower the water level below the flood level. Either the water valves have stuck on and are letting water in at a flow rate that is higher than the pump can handle, or the pump is blocked and can't remove the excess water.

Primary Source: Water Valves.

Action:

If the water valves are on continuously, check that the water valves turn off mechanically (remove power from machine).

Secondary Source: .Pump system

Action:

Check pump for blockage and drain hose for correct height and kinking

Tertiary Source: Motor Controller module. (Display Module Phase 1)

Action:

If water valves are being driven on electrically, replace Motor Controller module. (Display Module Phase 1)

13. (00001101) Phase 1 – Pump Fault

The Display module has detected that the pump is on when it should be off.

Action:

1. The pump is fitted with a thermal cut out device. Check if this device has been activated. If it has wait until the pump cools down before restarting. Check for any pump blockage and condition of pump before attempting to restart. ie. pump seizure.
2. Check for open circuit pump windings. Check the resistance of the pump.
3. Check the pump harness or the connectors for an open circuit.
4. Replace the Display Module.

14. (00001110) Phase 1 – Pump Connection Fault

The Display Module has detected that the pump is not on when it should be.

Primary Source – Pump

Action:

1. The pump is fitted with a thermal cut out device. Check if this device has been activated. If it has wait until the pump cools down before restarting. Check for any pump blockage and condition of pump before attempting to restart. ie. pump seizure.
2. Check for open circuit pump windings. Check the resistance of the pump.
3. Check the pump harness or the connectors for an open circuit.
4. Replace the Display Module.

15. (00001111) Phase 1 – Display Module Fault

The Display Module has read an incorrect voltage on the pump circuit

Primary Source: Display Module

Action:

Replace the Display Module.

Note: If SmartDrive is running at well below its rated supply voltage and the pump has operated for more than 4 seconds at the voltage this fault will also appear.

17 – 20. (00010xxx) Phase 1 – Display / Motor Controller out of Sequence

22 – 23. (000101xx) Phase 1 – Display / Motor Controller out of Sequence

Primary Source: The Display Module and Motor Controller are running out of sequence.

Action:

Turn the SmartDrive off at the wall and then back on again in 5 seconds. Restart.

If the fault persists, disable auto restart feature and retest. A new fault code will appear, carry out actions necessary to fix this new fault.

25. (00011001) Phase 5 IW – LCD Initialisation Error

The Intuitive Display has detected a problem with the LCD. Liquid Crystal Display

Primary Source: IW Display Module

Action: Replace IW Display Module

28 – 30. (000111xx) Phase 1 – Display / Motor Controller out of Sequence

Refer to fault code 17

32. (00100000) Phase 1 – Pump Circuit Error

The Display Module has detected that the pump is on when it is off.

Primary Source: Display Module

Action:

1. Check for moisture in the console area.
2. Replace the Display Module.

33. (00100001) Phase 1 – Water Valve Fault

The Module has detected a water valve fault.

Primary Source: Water Valve connection

Action: Check that both valves are connected up properly.

Secondary Source: Water Valve coil faulty

Action:

1. Check the valve coils are not open circuit.
2. Replace Display Module if the valve coils are not faulty.

34. (00100010) Phase 1 – Brake Resistor Fault

The circuit that controls the braking of the motor is faulty.

Primary Source: Motor Controller

Action: Replace Motor Controller

Secondary Source: Display Module

Action: Replace the Display Module

If the Display Module corrects the fault, then refit the original Motor Controller.

35. (00100011) Phase 1 – MC Reset Error

The Display Module has sent a false signal to the Motor Controller.

Primary Source: 12 way Harness Connection.

Action: Check the 12 way harness connection between the display Module and the Motor Controller.

Secondary Source: Display Module

Action: Replace the Display Module.

36. (00100100) Phase 1 to 6 - Water Leak Fault

The Motor Controller module has needed to top up the water level more than 4 times during agitate. This is excessive, as normally only one or two top ups are required to replace the air that has escaped from a full load during agitate. The most likely cause is that the machine is siphoning. The other alternative is that the machine has developed a leak.

Primary Source: Pump System.

Action

- 1) Check the height of the drain hose outlet. Minimum 33.4 in (850mm), Maximum 47 in (1200mm).
- 2) Check that the hose guide is fitted and check that the hose does not protrude more than (20mm) $\frac{3}{4}$ in beyond the guide.

Secondary Source: Mechanical.

Action:

- 1) Check the pressure tube connections on the Tub and Motor Controller module.
- 2) Check that the drive shaft seal and the pump housing seal have not developed a leak.

Tertiary Source: Motor Controller module.(Display Module Phase1)

Action: Replace Motor Controller module.(Display Module Phase 1)

37. (00100101) Phase 1 to 6 - Pump Blocked Error (No change in the water level)

While draining, the water level reading from the pressure sensor has not changed for over 3 minutes. There are three likely reasons for this fault. One is that the drain hose or the pressure switch hose has been squashed or kinked and the pump out rate has been dramatically reduced. The second possibility is that the pump is partially or fully blocked. The third is that the pump is not operating due to Motor Controller module, wiring or pump failure. This fault could also appear if the machine is pumping to an unusually high head of drain hose or into an extended length of drain hose. The Fourth possibility is a diverter valve fault or blockage, water level is not altering as the diverter is stuck in the recirculation mode, giving the module the appearance the pump is not lowering the water level.

Primary Source: Pump System.

Action:

- 1) Check that the drain hose has not been kinked.
- 2) Check the length of the drain hose and try to reduce the length if excessively long. A 39 inch (1 metre) extension hose of the same diameter fitted to the existing drain hose is the maximum allowable length.
- 3) Check for open circuit windings in the pump. (**Note:** Pumps are fitted with a thermal cut-out, which will reset on cooling.)
- 4) If the Tub is empty of water, remove the pump from the pump housing and check that it is not blocked. Also check the drain hose is not blocked.
- 5) If the Tub contains water, then service the pump from the top of the machine by removing the top deck and Basket. Bail out the water, remove the pump cap and hood and clear the restriction.

Secondary Source: Wiring.

Action:

- 1) Check the pump harness is connected correctly to the pump.
- 2) Check continuity of the pump harness.

Tertiary Source: Motor Controller module.

Action:

Activate the pump by operating the machine in spin mode. Check the pump is rotating. If it is not operating, and Primary and Secondary checks have been performed, then replace the Motor Controller module.

Note: Consider fitting Pump Hood Kit (WM013). If (5kg) 11lb SmartDrive fit splash guard to pump.

Quaternary Source: Diverter Valve failure (Phase 5 and 6 Eco's)

Action:

Check the diverter valve, see fault code 51

38. (00100110) Phase 1 to 6 - Pressure Sensor Fault

The Motor Controller module has recorded a water level of empty while it is agitating. The water level must have been greater than empty for the machine to enter the agitate mode initially. The most likely cause of this fault is that the pressure sensor hose has been severed or fallen off during agitate. Alternatively the pressure sensor may be faulty.

Primary Source: Mechanical.

Action:

Check that the pressure tube is intact and has not been cut.

Secondary Source: Motor Controller module. (Display Module Phase 1)

Action:

Replace the Motor Controller module if the pressure tube shows no sign of being faulty. (Display Module Phase 1)

39. (00100111) Phase 1 to 6 - Pressure Tube Fault

The probable cause of this fault is that the pressure tube has become blocked or kinked or has fallen off completely. Alternatively the pressure sensor may be faulty.

Primary Source: Mechanical.

Action:

Check that the pressure tube is intact and not blocked with water or dirt and is not kinked.

Secondary Source: Motor Controller module.(Display Module Phase 1)

Action:

Replace the Motor Controller module.(Display Module Phase 1)

40. (00101000) Phase 1 to 6 - Bowl Dis-engage Fault

While carrying out a Basket check, the Motor Controller module has found that the basket is not engaged even though the pressure sensor indicates that the Tub is empty. The Motor Controller module continues to check for 2 minutes, after which time it displays this fault. The first two areas to check are the clutch and the pressure tube. If these two appear correct, then the fault could be in the pressure sensor in the Motor Controller module.

Primary Source: Mechanical.

Action:

- 1) Check that there are no clothes or other foreign objects preventing the clutch from re-engaging. Excessive suds can stop the basket rotating.
- 2) If the machine is empty of water, carry out a clutch disassembly procedure and check the spline drive.
- 3) Next check that the pressure tube has not come off and that it is not kinked.

Secondary Source: Motor Controller module.(Display Module Phase 1)

Action:

Replace Motor Controller module.(Display Module Phase 1)

41. (00101001) Phase 1 to 6 - Temperature Sensor Fault (Thermistor)

The temperature sensor is measuring temperatures above 110°C. The fault is probably due to a short circuit in the sensor line. (Only in the Intuitive Washer and the GW Models.)

Primary Source: Thermistor (Phase 5 and 6) Motor Controller (Phase 1 to 4)

Action: Phase 1

1. Check connections of the 12 way harness
2. Check for moisture in the console area
3. Replace Motor Controller.
4. Replace Display Module, if the new display fixes the fault then refit the original Motor Controller.

Phase 2 to 4

Change Motor Controller module.

Phase 5 and 6**Action:**

1. Check the connection from the thermistor the Motor Controller
2. Check the resistance of the thermistor, should read 12.5k ohms at (20 degrees C) 68° F. Replace if faulty.

3. Replace the Motor Controller module.

42. (00101010) Phase 1 – Rotor Fault

Primary Source: The Motor Controller has had some confusing information feedback.

Action: Turn off SmartDrive at the wall and back on again after 5 seconds. Restart.

43. (00101011) Phase 1 to 6 - OOB Switch Fault

The Motor Controller module has found that the signal returning from the out of balance switch indicates that the switch is permanently on or the harness to it is disconnected.

Primary Source: Mechanical.

Action:

- 1) Check that the out of balance switch is free to move.
- 2) Check that no harnesses are blocking switch movement.
- 3) Check that the switch operates correctly when activated. Replace the switch if suspect.
- 4) If the out of balance micro switch shows signs of corrosion, replace the switch and switch harness, and fit a condensation kit to the console area if not incorporated in the top deck.
- 5) Check the level of the machine and also the bias spring.

Secondary Source: Wiring.

Action:

Check the harness to the switch is connected correctly. The terminals should be connected to the normally closed position. If the harness terminals show signs of corrosion, then fit a new harness.

Tertiary Source: Motor Controller module.(Display Module Phase1)

Action:

Replace Motor Controller module.(Display Module Phase 1)

44. (00101100) Phase 2 to 6 - Water in Tub during Spin

The Motor Controller has sensed a water level in the Tub during spin. This may be caused by a slow pump out rate due to a partial blockage in the pump hose or pump.

Primary Source: Pump System.

Action:

- 1) Check that the drain hose is not squashed or kinked.
- 2) Check the length of the drain hose and try to reduce the length if excessively long. A 39 inch (1 metre) extension hose of the same diameter fitted to the existing drain hose is the maximum allowable length.
- 3) If the Tub is empty of water, remove the pump from the pump housing and check that it is not blocked. Also check that the drain hose is not blocked.
- 4) If the Tub contains water, then service the pump from the top of the machine by removing the top deck and basket. Bail out the water, remove the pump cap and hood and clear the pump of any obstruction.
- 5) Check that water is not siphoning back into the machine when the pump turns off when the spin speed reaches 700 rpm

Secondary Source: Motor Controller module.

Action:

Replace Motor Controller module.

45. (00101101) Phase 5 Display Memory Check Fault

On power up, the display has checked its memory against a known reference and found differences.

Primary Source: Display Module.

Action: Replace Display Module.

46. (00101110) Phase 5 IW – Display EEPROM Check

The Intuitive Display has detected a problem with its internal EEPROM.

Primary Source: IW Display Module

Action: Replace IW Display Module

47. (00101111) Phase 2 and 3 - Basket Dis-engage Fault

While carrying out a Basket check, the Motor Controller module has found that the basket is not engaged even though the pressure sensor indicates that the Tub is empty. The Motor Controller module continues to check for 2 minutes. During this time the module has not been able to determine a valid tub status and so displays this fault. This fault differs from fault code 40 in that a valid tub status could not be determined. The first two areas to check are the clutch and the pressure tube. If these two appear correct, then the fault could be with the pressure sensor in the Motor Controller module.

Primary Source: Mechanical.

Action:

- 1) Check that there are no clothes or other foreign objects preventing the clutch from re-engaging.
- 2) Next check that the pressure tube has not come off and that it is not kinked.

Secondary Source: Motor Controller module.

Action:

Replace Motor Controller module, if the above checks out without fault.

48. (00110000) Phase 2 to 6 - Hot and Cold Valve Faulty

The Motor Controller module has measured voltages from the valve diagnostic circuit that indicate both the hot and cold valves are faulty. The most likely cause is that the valve harnesses have not been connected correctly or the valve is open circuit.

Primary Source: Wiring.

Action:

Check the valve harnesses are correctly fastened to the valves or the pins are not bent backwards.

Secondary Source: Water Valves.

Action:

Check the valve coils are not faulty (open circuit).

Tertiary Source: Motor Controller module.

Action:

Replace the Motor Controller module.

49. (00110001) Phase 2 to 6 - Cold Valve Faulty (proportional)

The Motor Controller module has measured a voltage from the valve diagnostic circuit that indicates the cold valve is faulty. The most likely cause is that the valve harness has not been connected correctly or the valve is open circuit. See fault code 48 for service procedure.

50. (00110010) Phase 2 to 6 - Hot Valve Faulty (digital)

The Motor Controller module has measured a voltage from the valve diagnostic circuit that indicates the hot valve is faulty. The most likely cause is that the valve harness has not been connected correctly or the valve is open circuit. See fault code 48 for service procedure.

Note: Phase 5 can give a fault code 50 when the SmartDrive powers off while spinning. There will actually be no fault if this has happened.

51. (00110011) Phase 5 and 6 Eco - Diverter Valve Fault

Primary: The motor controller has registered a drop in water level in the recirculation phase of the wash cycle, water is being drained instead of recirculated. Or water has been sprayed onto the valve from an external source and caused the solenoid to blow.

Action:

Turn the power off at the machine but leave the power on at the wall, then measure the voltage across the terminals of the wax actuator, if a reading of 120V is achieved the motor controller has failed due to the valve and both will need to be replaced.

Secondary: Check for blockage in the valve itself or a broken hinge mechanism.

52. (00110100) Phase 5 and 6 Eco - Diverter Top-up Fault

More than 6 attempts to top-up the water level in the tub, this then signifies the valve has not closed and is diverting to drain, or the top-up was not increasing quick enough suggesting the valve has a blockage and is also draining.

Primary Source: Diverter valve

Action: Remove the diverter valve and check for blockages or broken hinge mechanism.

Secondary Source: Wax Solenoid

Action:

Check the resistance of the wax solenoid, also look for corrosion on the terminals (greenie deposit) resistance range will be between 0.7k Ω and 2.5k Ω . Values are dependant on ambient temp and when the valve was last actuated. Anything outside of these values should be automatically replaced.

53. (00110011) Phase 2 to 6 - Rotor Position Sensor Step Fail

The motor controller has attempted a motor step test and has found that the motor has not stepped in the correct direction. It has detected that the motor is connected and that the motor drive is operational. The rotor position sensing system is at fault here.

Primary Source: Wiring.

Action:

Check the Rotor Position Harness for continuity and that the connectors are correctly to the Rotor Position Sensor and the Motor Controller.

Secondary Source: Rotor Position Sensor

Action:

Check the Rotor Position Sensor patterns with a RPS Tester, if faulty fit a new Rotor Position Sensor.

Tertiary Source: Motor Controller module.

Action:

Replace the Motor Controller module as the sensing circuitry may be faulty.

54. (00110110) Phase 2 to 6 - Motor/Motor Controller module Step Fail

The Motor Controller module has attempted a motor step test and has found that the motor has not stepped in the correct position. The Motor Controller module has detected that there is no current. This indicates that either the motor is not connected or the Motor Controller module motor drive is faulty.

Primary Source: Wiring.

Action:

Check the continuity of the motor harness and that the connectors are correctly applied to the motor and Motor Controller module.

Secondary Source: Motor.

Action:

Check continuity of motor phases. Check the bridge terminal on the stator is not open circuit or burnt. Replace the stator.

Tertiary Source: Motor Controller module.

Action:

Replace Motor Controller module.

55. (00110111) Phase 3 to 6 – System Step Fail

Primary Source: Rotor Position Sensor

Action:

1. Check Motor and Rotor Position Sensor wiring
2. Check Rotor Position Sensor with RPS Tester

56. (00111000) Phase 4 to 6 - Basket Check No Valid Fault

While carrying out a basket check, the machine has not been able to determine a valid basket status and so the Display flags this fault. This fault differs from fault 40 in that a valid basket status could not be determined.

Phase 4 & 6

Primary Source: Loading.

Action:

Remove items until the remaining ones can move freely, or rearrange the load so that the clothes are evenly distributed around the basket, or select a higher water level. If the load was to one side of the basket or too heavy it can be possible for the agitator to bind in one direction when trying to sense basket float.

Secondary Source: Mechanical.

Action:

1. Check the machine is not syphoning.
2. Check that there are no clothes or other foreign objects preventing the clutch from re-engaging, and that there aren't any defects with the clutch mechanism.
3. Next check that the pressure tube has not come off and that it is not kinked.

Tertiary Source: Rotor Position Sensor.

Action:

Replace the Rotor Position Sensor.

Quaternary Source: Motor Control Module.

Action:

Replace the Motor Control Module.

- 57. (00111001) Phase 4 to 6 - Brown Out During Display EEPROM Write Fault**
The Display has requested the Motor Controller module to perform an EEPROM write. Prior to writing, the Motor Controller has tested the 15 Volt supply and found that it is below the safety level for writing EEPROM and has reported this to the Display. This may be due to transients at the time of writing or due to a faulty Motor Controller module.
Primary Source: Motor Controller module.
Action:
Replace Motor Controller module.
- 58. (00111010) Phase 4 to 5 - Pressure Transducer at Maximum Adjustment Fault**
When the pause or delay start is pressed to start the machine, the Display has checked the memory and found the count greater than expected.
Primary Source: Motor Controller module.
Action:
Replace Motor Controller module.
- 59. (00111011) Phase 4 to 5 - I D Out of Range Fault**
When the pause or delay start is pressed to start the machine, the Display checked the physical ID and found it was out of range.
Primary Source: Display module.
Action:
Replace Display module.
- 60. (00111100) Phase 4 to 6 - Motor Control Memory Check Fault**
On power up, the Motor Controller module has checked its memory against a known reference and found differences.
Primary Source: Motor Controller module.
Action:
Replace Motor Controller module.
- 61. (00111101) Phase 4 - Brown Out During Motor Controller EEPROM Write Fault**
The Motor Controller module has been attempting to perform an internal EEPROM write. Prior to writing, the Motor Controller has tested the 15 volt supply and found that it is below the safety level for writing EEPROM and has reported this to the display.
Primary Source: Motor Controller module.
Action:
Replace Motor Controller module.
- 62. (00111110) Phase 5 - Pump Over Current**
The Motor Controller module has detected an excessive pump current.
Primary Source: Pump.
Action:
Replace Pump.
Secondary Source: Motor Controller module.
Action:
Replace Motor Controller module.

- 63. (00111111) Phase 5 - Pump Comms Error**
 The Motor Controller module has detected an internal communications problem between its main control system and the pump control system.
Primary Source: Motor Controller module.
Action:
 Replace Motor Controller module.
- 64. (01000000) Phase 5 and 6 - Pressure Transducer (Ptx) error frequency < 66 kHz**
 The Motor Controller module has received signals from the water level sensor (Ptx) below normal frequency values.
Primary Source: Motor controller module.
Action: Replace Motor Controller module.
- 65. (01000001) Phase 5 and 6 - Pressure Transducer (Ptx) error frequency > 90 kHz**
 The Motor Controller module has received signals from the water level sensor (Ptx) above normal frequency values.
Primary Source: Motor Controller module.
Action:
 Replace Motor Controller module.
- 66. (01000001) Pressure Transducer Error [Ptx Frequency > 90 kHz]**
Note: this supersedes Fault code 65 from V41 Motor controller code onwards.
 The Motor Control module has received signals from the water level sensor (Ptx) above normal frequency values.
Primary Source: Motor Control module
Action: Replace Motor Control module
- 81. - 95. (0101xxxx) Phase 2 to 3 – Display/ Motor Controller. See fault code 106**
- 104. (01101000) Phase 2 to 6 See fault code 106**
- 105. (01101001) Phase 2 to 6 Comms Error Time out**
 These faults are reported when the Display module detects an error in the communications between the Display module and the Motor Controller.
 Note: If the product is an IW the wrong Motor Controller may have been fitted.
 Replace with a compatible part.
Primary Source: Display Module
Action: Replace Display Module
Secondary Source: Motor Controller
Action: Replace Motor Controller
Tertiary Source: Rotor Position Sensor (Phase 5 and 6)
Action: Replace Rotor Position Sensor, if this corrects the fault refit the original Display or Motor Controller.
- 106. (01101010) Phase 2 to 3 - Display to Motor Controller module Communications Errors (Phase 6 IW also)**
 These faults are reported when the Display module detects an error in the communications between the Display module and the Motor Controller module.
Primary Source: Display module.

Action:

Replace Display module.

Secondary Source: Motor Controller module.

Action:

Replace Motor Controller module. If the new Motor Controller module corrects the fault, refit the original Display module.

107. (01101011) Phase 2 to 6 - Motor Controller module Reset Error

The Display Module has detected that the Motor Controller module has reset when it should not have. This can be due to a Motor Controller module supply disturbance or microprocessor failure.

Primary source: Motor Controller module.

Action: Replace Motor Controller module.

108. (01101100) Coms CRC error Phase 6 IW Display only See fault code 106**127. (01111111) Phase 5 – Machine Set up Error**

The display module has been fitted to the wrong model, size and or phase machine! eg. Phase 5 Display cannot be fitted to a Phase 4 Motor Controller! The colour of the modules is a good indicator, part numbers are also very important.

130. (10000010) Phase 1 to 6 Single Rotor Position Sensor Error

The Motor Controller has found an error in the pattern received from the Rotor Position Sensor. Likely causes of this fault are a bad connection on the harness between the Rotor Position Sensor and the Motor Controller, or a faulty Rotor Position Sensor.

Primary Source: Wiring.

Action:

- 1) Check for corrosion on the edge connector of the Rotor Position Sensor and the Motor Controller module connector.
- 2) Check the contacts on the rotor positional sensor end of the hall harness to see if any have been damaged. (Each set of contacts in the socket has two wipers. If the distance between these wipers varies between different contacts, replace the rotor positional sensor harness).

Secondary Source: Rotor Position Sensor.

Action:

Check the Rotor Position Sensor with an R.P.S. tester. Replace if faulty.

Tertiary Source: Motor Controller module.

Action:

Replace Motor Controller module.

131. (10000011) Phase 1 to 6 - Repetitive Rotor Position Sensor Error

This fault is similar to fault number 130 above but differs slightly in that it is a continuous condition. See fault code 130 for service procedure.

132. (10000100) Phase 1 to 4 - Single Current Trip

The Motor Controller has detected excess current in the motor or electronic switches. This fault has occurred momentarily.

Primary Source: Wiring.

Action: Check the wiring connections from the Motor Controller to the Stator and the Rotor Position Sensor.

Secondary Source: Motor.

Action

- 1) Measure/check the motor harness, connectors and motor for shorts. This can be done by taking a resistance measurement between phases of the motor harness at the Motor Control module end. Nominal resistance should be around 12.2 ohm for Phase 2, 3 & Phase 4. For Phase 5 and 6 SmartDrive the nominal resistance should be around 32 ohms.
- 2) Check the Rotor Positional Sensor, Stator brass bridge terminal point and associated harness for water, mechanical damage or corrosion.

Tertiary Source: Motor Controller module.

Action

If all the above show no signs of fault then replace the Motor Controller module. Also check for water leaks from the cooling chamber or valves that could possibly come in contact with the Motor Controller and fix the leak before replacing with new Motor Controller module.

133. (10000101) Phase 1 to 4 - Repetitive Current Trip

The Motor Controller has detected excess current in the motor or electronic switches. This fault is a more severe occurrence than Fault Number 132 but has identical fault sources and fault service procedure.

134. (10000110) Phase 4 - Single Current Trip & Rotor Position Error

The Motor Controller module has detected an excessive motor current and a Rotor Position Sensor error simultaneously. See fault codes 130 and 132 for service procedure.

136. (10001000) Phase 1 to 6 - Motor Stall

The Motor Controller has been unable to start the motor. Possible causes of this fault are: Faulty motor harness, faulty or jammed motor, seized bearings or seals, faulty Motor Controller module, faulty Rotor Position Sensor or harness.

Primary Source: Wiring.

Action:

Measure / check the motor harness, connectors and motor for discontinuity. This can be done by taking a resistance measurement between phases of the motor harness at the Motor Controller module end. Nominal resistance should be around 12.2 ohm for Phase 2,3 & Phase 4. For Phase 5 and 6 onwards the nominal resistance should be around 32 ohms.

Secondary Source: Motor.

Action:

- 1) Check free rotation of the agitator and basket by rotating by hand. Bearings and seals may be seized.
- 2) Check the Rotor Position Sensor and associated harness for water, mechanical damage or corrosion.

Tertiary Source: Motor Controller module.

Action:

If the primary and secondary checks pass inspection then replace the Motor Controller module.

144. (10010000) Phase 1 – Motor Controller Software Trap

The Motor Controller has developed a fault.

Primary Source: – Motor Controller

Action:

1. Power off for 5 seconds and try again.
2. Check connections between the Display Module and the Motor Controller
3. Replace Motor Controller

160. (10100000) Phase 1 to 6 – Basket Engaged

The basket has re-engaged itself during agitate. Possible causes for this are a leak in the air bell, the basket is over-loaded with clothes, or the clutch has jammed or is fouled with a foreign object.

Primary Source: Mechanical.

Action:

- 1) Check that the rotating basket assembly is not jammed to the agitator with any foreign object that may be caught under the agitator skirt.
- 2) Check that the clutch teeth are not locked together with dirt, lint, etc.
- 3) Make sure the basket is not overloaded with too many clothes.
- 4) If none of the above appear to be at fault, then check the air bell at the bottom of the basket for leaks.

Secondary Source: Motor Controller module. (Phase 1 to 4 only)

Action:

If the machine is empty of water at fault it is possible that the pump circuit is faulty and has caused a pump out during wash. This would cause the basket to re-engage during agitate and the Motor Controller module to display this fault. Replace Motor Controller module.

161. (10100001) Phase 2 to 6 - Hardware / EEPROM Supply Mismatch

The Motor Controller checks the hardware configuration (ie. 110v or 230v) against its EEPROM table on power up. Should there be a mismatch, this error is flagged.

Primary Source: Motor Controller module.

Action: Replace Motor Controller module.

162. (10100010) Phase 3 to 5 - Brake Deceleration Time-out Fault

During the brake mode, the Motor Controller has detected that the basket has not come to a stop in the permitted time once dropping below 100rpm. This fault has been installed for software testing only.

163. (10100011) Phase 4 to 6 - Valve Reset Pin Connect Fault

The Motor Controller has sensed the PCB connection is open circuit. The cold valve cannot operate with this condition.

Primary Source: Motor Controller module.

Action:

Replace Motor Controller module.

164. (10100100) Phase 4 to 5 - Brake Function Time-out Fault

This fault indicates that the Motor Controller has been attempting to brake for 20 seconds. As all spin loads should come to rest within 10 seconds, something has gone wrong during the brake to prevent the basket stopping in time.

Primary Fault: Wiring.

Action:

Measure / check the motor harness, connectors and motor for continuity. This can be done by taking a resistance measurement between phases of the motor harness at the Motor Controller module end. Nominal resistance should be approximately

12.2 ohms for Phase 2,3 & Phase 4. For Phase 5 SmartDrives the nominal resistance should be approximately 32 ohms.

Secondary Source: Motor Controller module (Phase 4) RPS (Phase 5).

Action:

Replace Motor Controller module (Phase 4) or Rotor Position Sensor (Phase 5).

192. (1100000) Phase 4 to 5 - Motor PWM Reset Pin Connect Fault

The Motor Controller has sensed an open circuit between pins 30 and 31. The motor cannot operate with this condition.

Primary Source: Motor Controller module.

Action:

Replace Motor Controller module.

230. (11100110) Phase 6 - EEPROM Value out of Range

Wrong version detected

Primary Fault: Motor controller is the wrong version

Action: Change motor controller

231. (11100111) Phase 6 - MW GW Link Error

Component has failed on the display board.

Primary Fault: Display Module fault

Action: Replace Display module

232. (11101000) Phase 6 - COMMS Timeout 5 Sec

IW only problem, either the Display or motor controller has not responded in time.

Primary Fault: Display

Action: Replace Display

Secondary Fault: Motor controller

Action: Replace Motor controller

233. (11101001) Phase 6 - EEPROM Read Error

Problem reading the EEPROM data coming from the Motor controller

Primary Fault: Motor controller faulty

Action: Replace Motor controller

234. (11101010) Phase 6 - Lid Lock Open Circuit

Check Harness to Lid Lock and connections at the motor controller and lid lock ends.

Primary Fault: Connector to the harness, either end could be at fault.

Action: Replace Harness.

Secondary Source: Lid Lock has failed to be activated.

Action: Replace Lid Lock housing.

Tertiary Source: **Motor Controller has not responded to the Lid Lock being activated**

Action: Check the lid has a Tang and is fitted correctly to activate the Lid Lock, if this is all in order the motor controller must be at fault and needs to be replaced.

235. (11101011) Phase 6 - Lid Lock Short Circuit

Lid Lock fault, not activated when instructed to by the motor controller

Primary Fault: Lid Lock mechanism has jammed or failed

Action: Check resistance across the connections, should be around **73 ohms**, if not within **5 ohms** replace the Lid Lock.

236. (11101100) Phase 6 - Incompatible EEPROM Version

Failure to start and fault immediately displayed

Primary Fault: Motor controller is the wrong one.

Action: Replace motor controller.

237. (11101111) Phase 6 - Temperature Sensor Error

The electronics have picked up a continuity problem, same as fault code 10 or 41.

Primary Fault: The sensor has failed either in the harness or connection to the thermistor.

Action: Replace the Thermistor (temperature sensor)

Secondary Source: Motor controller has failed to read the temperature, check connections.

Action: Replace motor controller if connections look fine and the fault still occurs.

238. (11101110) Phase 6 - Lid Lock Fail In-Line Test (1)

Final on line tests, final check before going to the field.

239. (11101111) Phase 6 - Lid Lock Fail In-Line Test (2)

Final on line tests, final check before going to the field

240. (11110000) Phase 6 - Hall Out Of Order. RPS Fault

Same as previous Hall Error faults, just an extra fault code for phase 6, see code 130,131 for directions.

241. (11110001) Phase 6 - Function Time Out

Display crashed

Primary Fault: Display has failed

Action: Replace Display Module

Secondary Fault: Motor controller has failed

Action: Replace Motor controller

242. (11110010) Phase 6 - OOB Hit Greater than Max for 5 Sec

Out Of Balance warning to the user, additional fault code for Phase 6

Primary Fault: Machine has detected the Tub movement to be excessive or the Micro switch is permanently on or harness to it is disconnected.

Action: See fault code 43 for details.

243. (1110011) Phase 6 - Stepper Test Failure

Rotor Position Sensor Fault, the motor controller has attempted a motor step test and found the motor has not stepped to the correct position.

Primary Fault: Wiring

Action: See Fault code 53 and 54.

NOTES