

BMR FCR05, FCR07

Power factor correction controller

User and service manual



version 3.2

Content

1. Control and signal elements.....	3
2. Device description.....	4
3. Instruction manual for connection and operation.....	4
4. Description of the function.....	5
5. Installation of the device.....	6
6. Controller parameter setting.....	8
6.1. Target $\cos\phi$ setting (CoS).....	10
6.2. Current transformer ratio setting (Itr).....	10
6.3. Automatic detection of compensation stages (Aut).....	10
6.4. Deceleration of regulation at over compensation (Sht).....	10
6.5. Manual setting of compensation stages (StP).....	10
6.6. Discharging time (dit).....	11
6.7. Delay for disconnection (diP).....	11
6.8. Fixed capacitor stages (FSt).....	11
6.9. Connection configuration (Con).....	11
6.10. Regulation to average or instantaneous power factor ($_CS$).....	12
6.11. Averaging time for APFR (tAC).....	12
6.12. Recording of number of operations and maximum values (CSt).....	12
6.13. De-compensation steps settings (EIC).....	13
6.14. Alarms.....	13
6.15. Configuration of RS485 communication port.....	14
6.16. Password for entering configuration mode (Cod).....	14
6.17. Restart (rES).....	14
7. Displayed values.....	15
7.1. $\cos\phi$	15
7.2. Apparent current.....	16
7.3. Voltage.....	16
7.4. Powers.....	16
7.5. De-compensation delay.....	16
7.6. Step operation number and time.....	16
8. Manual operation.....	16
9. Alarm notification.....	16
10. Technical features.....	18

1. Control and signal elements

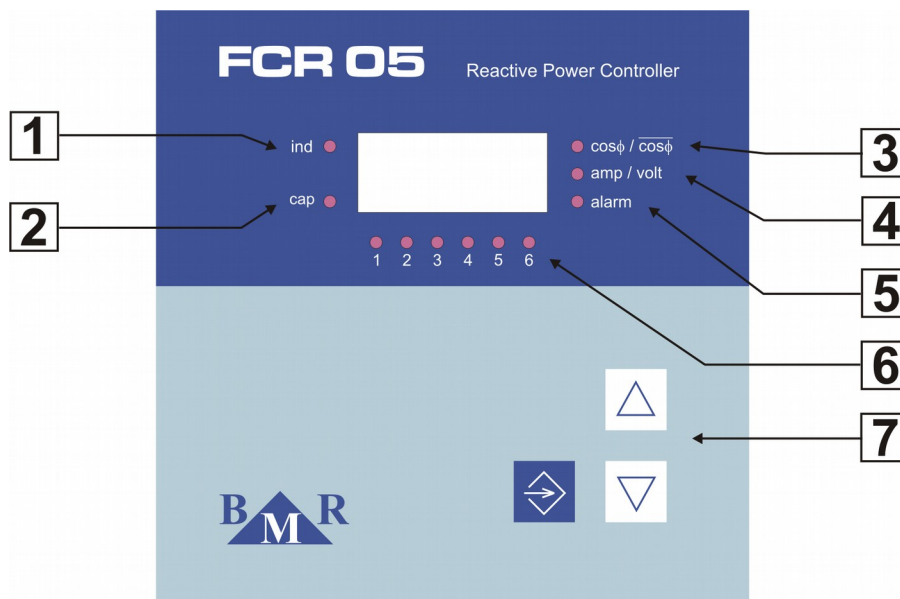

Picture 1. Description of front control panel

1. **LED ind** – it is ON in the case of inductive $\cos\phi$
2. **LED cap** – it is ON in the case of capacitive $\cos\phi$
3. **LED cosF** – it is ON when instantaneous or average value of $\cos\phi$ is shown on the display
4. **LED amp/volt** – it is ON when value of measured current/voltage is shown on the display
5. **LED alarm** – it is ON when alarm is present
6. **LED STAGES** – those LEDs indicate status of each stage individually
7. Buttons for regulator control

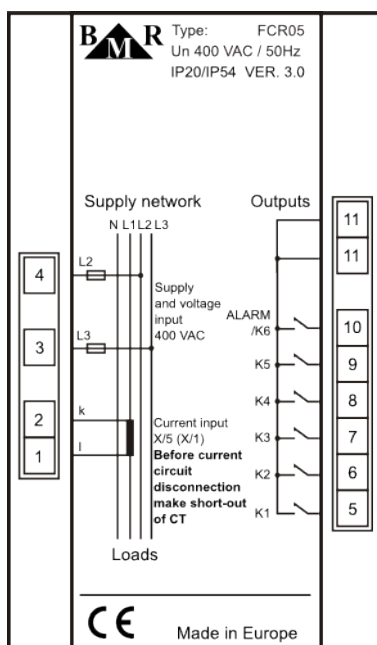

Picture 2. Device terminal connection

2. Device description

Power factor correction regulator FCR05 and FCR07 are designed for reactive power control in low and medium voltage grids 50/60 Hz. FCR05 and FCR07 allows to control compensation cabinets with 6 (FCR05) respective 8 (FCR07) contactor steps.

FCR05 and FCR07 controllers do not have independent alarm output but the last step can be set as an alarm output and this case it is not used for capacitor step operation but only for alarm purposes.

FCR05 and FCR07 controller measures also following parameters:

Parameter	Display	Maximum
Instantaneous $\cos\phi$, average $\cos\phi$ (capacitive, inductive)	•	
Measuring voltage	•	•
Current in the measured phase	•	•
Apparent three-phase power	•	•
Active three-phase power	•	•
Reactive three-phase power	•	•
Allowed reactive power	•	•
Odd current harmonics (1 ... 19) in %	•	•
Total harmonic distortion of current THDI	•	•
Odd voltage harmonics (1 ... 19) in %	•	•
Total harmonic distortion of voltage THDU	•	•
Number of connections of each stage	•	
Total time of step usage of each step	•	
Temperature	•	

Table 1. Measured and displayed parameters

Power factor correction controllers FCR05 and FCR07 are produced in following variants.

Regulator variant	Number of all stages	Supply and measuring voltage	Panel mounting	DIN rail mounting
FCR05	6	400 VAC	•	
FCR07	8	400 VAC	•	
FCR05DL	6	400 VAC		•
FCR08DL	8	400 VAC		•
FCR05V230	6	230 VAC	•	
FCR07V230	8	230 VAC	•	
FCR05DLV230	6	230 VAC		•
FCR08DLV230	8	230 VAC		•

Table 2. Controller variants according to power supply and measuring voltage

3. Instruction manual for connection and operation

Default parameters are set to the device in production, according to the table 1. Supply voltage has to be taken from regulated network, because it is used also for voltage measuring circuit. Value of this supply voltage is on the product label. Current for current measuring circuit can be take from any phase. By default the connection of the regulator is that voltage is connected between phase L2 – L3 and current transformer to the phase L1. The connection of device is shown at picture 5 and 6.

Commissioning procedure:

1. Make connection according to connection diagram at picture 5 or 6.
2. Connect supply voltage. In the case that the value of current is lower than 5 mA, the display will show '---'. If not, the display will show instantaneous value of power factor.
3. Hold button **SET** for at least 5 seconds. After that device will switch to the service menu and on the display will appear parameter **CoS**.
4. By pressing the button **SET** once again display will show target $\cos\phi$. Setting the targeting values of $\cos\phi$ is done via buttons **▲** (+) and **▼** (-).
5. Confirmation of the set value **CoS** is done by pressing the button **SET**.
6. Press the button **▲** until the parameter **ltr** will appear on the display. This parameter means transformer ratio of

current transformer.

7. Press the button **SET** and on the display will appear set value of transformer ratio (default value is 1).
8. Using the buttons **▲**, **▼** set known value of transformer ratio.
9. By pressing button **SET** confirm set value. On the display will appear again the parameter **Itr**.
10. Now again, by using the buttons **▲**, **▼** move to the parameter **Aut** and by pressing button **SET** confirm it. Via button **▲** switch to the value **on** and via button **SET** confirm set value. Device automatically perform phasing of measured voltage, current and detection of connected compensation stages. All parameters will be saved to the internal memory. When the detection is finished, parameter **Aut** will be automatically changed to the value **off**.
11. Verify if detection of power of all stages was done correctly. Press button **SET** for time of 5 seconds to enter service mode. By pressing button **▲** move to the parameter **StP**. Press again button **SET** and **LED 1** of first stage will turn On. Another pressing the button **SET** will make the value of the power of the first stage be shown on the display. If the value is not correct, it should be changed by pressing buttons **▲**, **▼** until the correct value. In the case of capacitor stage, **LED cap**, placed at the left side of display, has to light. If the power is correct press again button **SET** and on the display will appear again parameter **StP**. Via button **▲** move to another stage and **LED 2** will turn On. Repeat the same procedure the same way like for the first stage. Following the same control or setting of all stages should be done. At the end press button **SET** until value of power factor will appear on the display.
12. If everything is set correctly, on the display is shown real instantaneous value of power factor. Regulator FCR05 or FCR07 is ready for operation.

Other parameters may remain on having the default values, that were made by the manufacturer. In the case that further changes are necessary, the user should follow detailed manual given in chapter 6.

4. Description of the function

Device digitizes measured phase to phase voltage between two phases and current in the measured phase. Then, from those values, parameters like: power factor, effective values of voltage and current, harmonic distortion of voltage and current, are being counted. Calculation of the needed compensation power is done by using the value of allowed reactive power, which is set in the device in the form of requested power factor. According to its size, regulator will switch on or switch off appropriate capacitor stages.

Within the scope of each power level, regulator uses method of circle switching. All the time connects this stage at appropriate power level which was switched off for longest time. Everything is made so that regulator will reach optimal compensation in one regulation cycle with minimum number of switched stages.

The regulator makes harmonics analysis of current and voltage up to 19th harmonics and counts THD factor of voltage and current.

5. Installation of the device

Regulators FCR05 and FCR07 (except variant for DIN rail) is designed in metal box, which provides perfect EMC shielding. Controller's design also provides panel mounting, into the hole 91 x 91 mm. The connection of the wires is from the back side of regulator, to the terminal box. Measuring and auxiliary voltages are being taken from supply voltage, which must be protected by fuse 6 A.

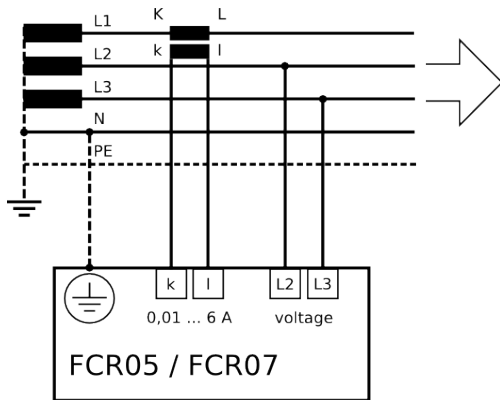

Picture 3: Connection of measuring circuits

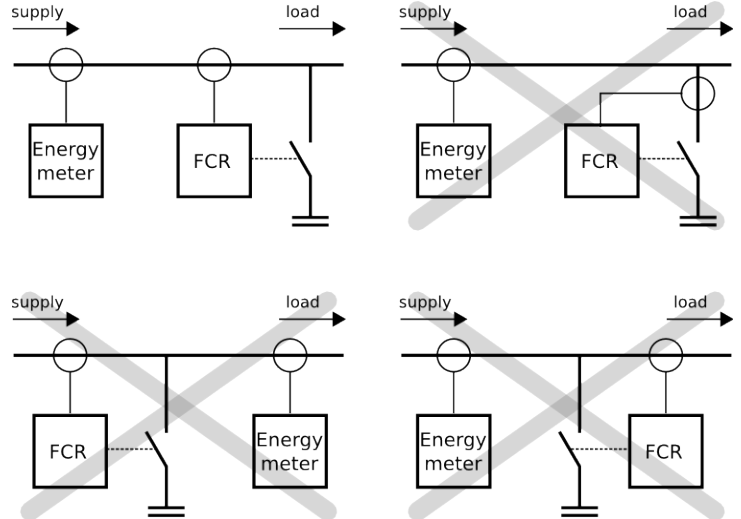

Picture 4: Position of FCR12 controller in the system

Location of the current transformer has to allow both current of the load and the current of the capacitor to be measured together. Correct location is shown on the picture 4 as well as examples of wrong location.

The complete connection is shown at the picture 5. There is only one rule that should be considered. Stages with the same power have to be connected side by side. For example:

1 st stage	2 nd stage	3 rd stage	4 th stage	5 th stage	6 th stage
6,25 kVAr	6,25 kVAr	12,5 kVAr	-	25 kVAr	25 kVAr

However, ranging the powers in accordance is not necessary. There could be even gaps between particular power levels. For example, stages 1 and 2 could be connected, then stage 3 disconnected, stages 4 and 5 connected and so on.

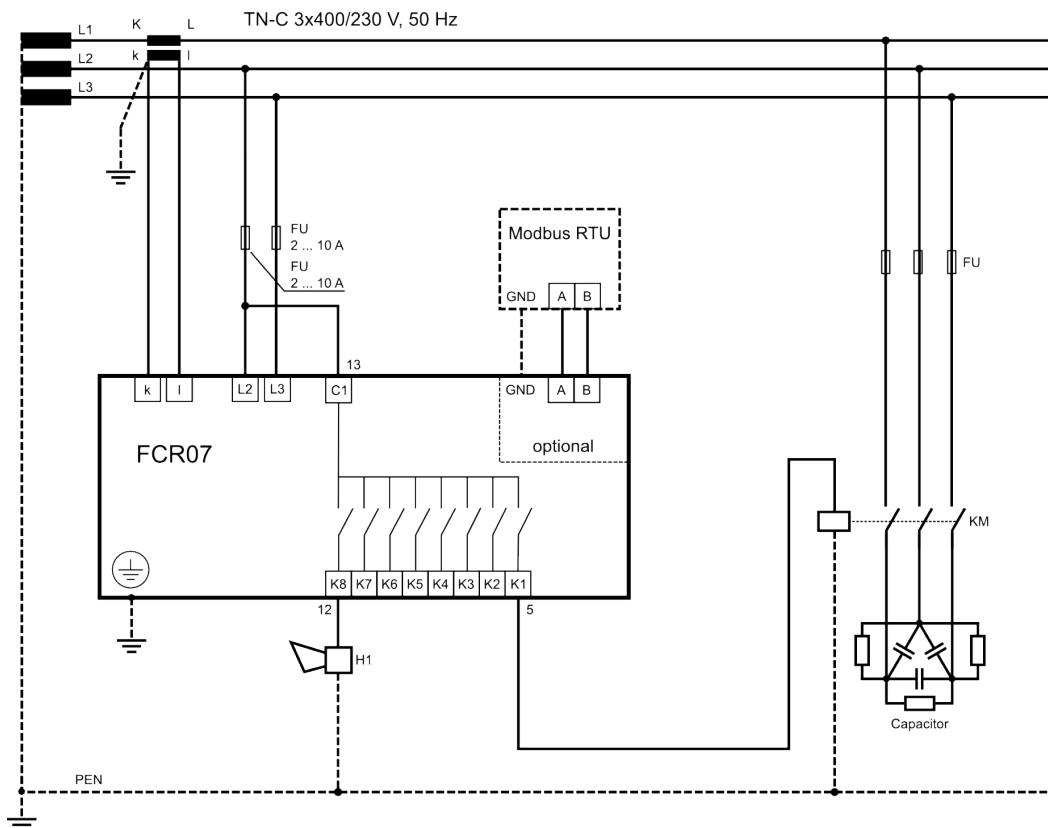

Picture 5. Connection of FCR07 controller for standard supply voltage 400 VAC

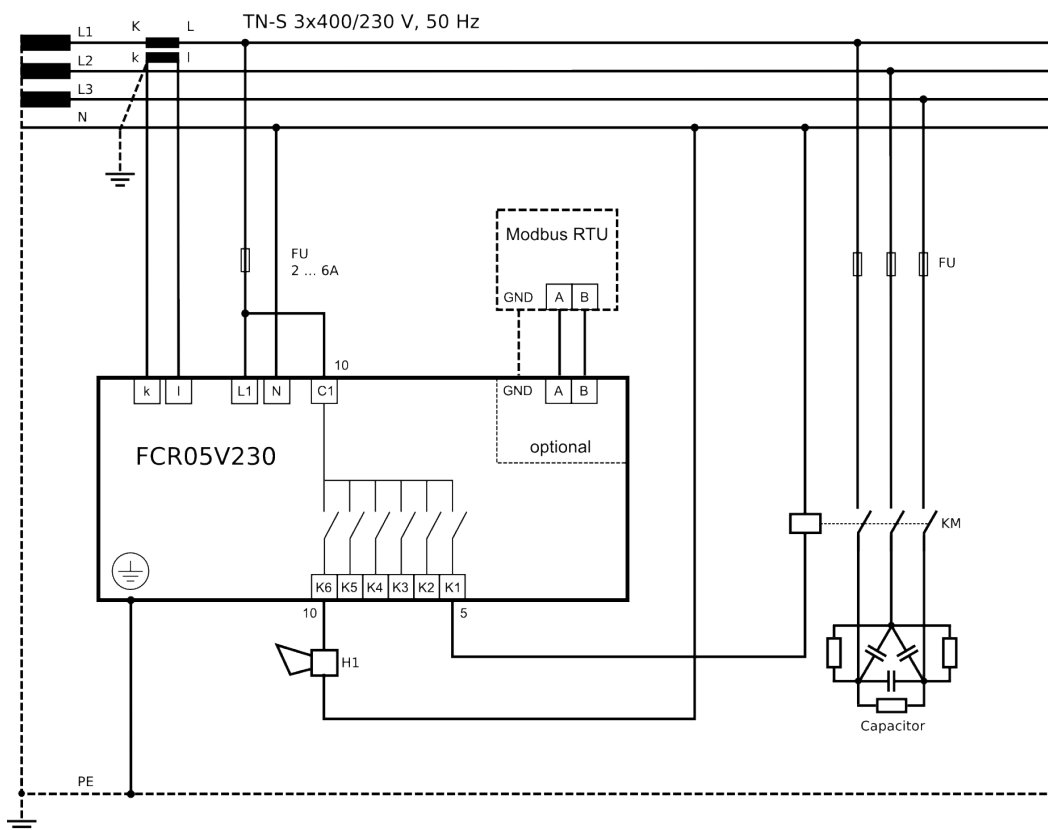

Picture 6. Connection of FCR05V230 controller for supply voltage 230 VAC

6. Controller parameter setting

Considering various usage of controllers FCR05 and FCR07, there is a number of programmable parameters. For easy start, regulator is set to default parameters, made by manufacturer. Set parameters are stated in the following table.

For fast start, the parameters that should necessary be set are $\cos\phi$ and transformer ratio of current transformer. Eventually, transformer ratio of voltage transformer could also be set. Further more, there are also other parameters that could be set, in accordance to the customer request.

In order to avoid any unwanted reprogramming of the device, it is possible to protect access to service mode by setting the three digits password. By default, new controller does not have any password protection activated. It is recommended to activate password protection after setting all parameters. After the protection has been activated, it is possible to see all set parameters, but not to change any of them.

For checking respective setting set parameters follow those instructions:

1. Press the button **SET** for 5 seconds. Device switches to the service mode and parameter **CoS** will appear on the display. This is a symbol of parameter whose currently set value will appear after another pressing of button **SET**.
2. Via buttons **▲**, **▼** is possible to set the requested value of specified parameter.
3. By pressing the button **SET** again, regulator will save changed value to the internal memory and on display symbol of the set parameter will appear again. Via buttons **▲**, **▼** it is possible to move to another parameter (see the table below).
4. If the offered parameter is not the one, which is requested to be modified, follow via buttons **▲**, **▼** to the requested parameter.
5. Regulator turns back automatically from service mode after 1 minute without any keyboard action, or by repeated pressing of button **SET** during returning from parameter value setting.

Important

While service mode is activated, device is not regulating. Controller will not react to the power factor changes, neither to the changes of other monitored variables. Alarm output will not operate as well.

Parameter	Description	Factory setting	Setting range
CoS	target $\cos\phi$	ind 0,98	0,80 cap. ... 0,80 ind. in steps of 0,01
Itr	current transformer ratio	1	1 ... 999 in steps of 1
Utr	voltage transformer ratio	1	1 ... 300 in steps of 1
Aut	automatic detection of compensation stages	oFF	on / oFF
SHt	deceleration of regulation in the case of over-compensation	60	0 ... 999 s in steps of 1 s
StP	manual setting of compensation stages	0	999 kVAr C ... 999 kVAr L in step of 0,1kvar
dIt	discharging time for contactor stage	30	5 ... 900 s in step of 5 s or overdrive of 50 s
dIP	delay for disconnection of contactor stage	15	5 ... 900 s in step of 5 s or overdrive of 50 s
rSt	number of circuit closing of contactor stage	999	1 ... 999 (x100 operations)
FSt	fixed capacitor stages	Aut	Aut / oFF / on
Con	connection configuration	90	0° ... 330° in steps of 30°
orP	reactive power offset for regulation	0	999 kVAr C ... 999 kVAr L
_CS	regulation to the average power factor	on	on / oFF / Aut – off regulates on instant. $\cos\phi$
tAC	averaging time for APFR regulation	60	15, 30, 45, 60 minutes
CSt	saving the step operations and maxim to non volatile memory	oFF	on / oFF
EIC	activation of inductive steps for de-compensation	oFF	on / oFF
uLA	under-voltage alarm	oFF	on / oFF
uL	voltage trigger value for an alarm activation	0	0 ... 750 V
tuL	minimum event duration for an alarm activation	0	0 ... 900 s
ouL	alarm event disconnects compensation steps	oFF	on / oFF

uHA	over-voltage alarm	oFF	on / oFF
uH	voltage trigger value for an alarm activation	0	0 ... 750 V
tuH	minimum event duration for an alarm activation	0	0 ... 900 s
ouH	alarm event disconnects compensation steps	oFF	on / oFF
ILA	under-current alarm	oFF	on / oFF
IL	current trigger value for an alarm activation	0	0 ... 5 A
tIL	minimum event duration for an alarm activation	0	0 ... 900 s
oIL	alarm event disconnects compensation steps	oFF	on / oFF
IHA	over-current alarm	oFF	on / oFF
IH	current trigger value for an alarm activation	0	0 ... 8 A
tIH	minimum event duration for an alarm activation	0	0 ... 900 s
oIH	alarm event disconnects compensation steps	oFF	on / oFF
CoA	alarm for $\cos\phi$, that is permanently over set limits	oFF	on / oFF
_Co	$\cos\phi$ level value for an alarm activation	0	0,80 cap. ... 0,80 ind.
tCo	minimum event duration for an alarm activation	0	0 ... 900 s
oCo	alarm event disconnects compensation steps	oFF	on / oFF
HuA	alarm of voltage harmonic distortion	oFF	on / oFF
Hdu	THDU trigger value for an alarm activation	0	0 ... 50 %
tHu	minimum event duration for an alarm activation	0	0 ... 900 s
oHu	alarm event disconnects compensation steps	oFF	on / oFF
HIA	alarm of current harmonic distortion	oFF	on / oFF
HdI	THDI trigger value for an alarm activation	0	0 ... 300 %
tHI	minimum event duration for an alarm activation	0	0 ... 900 s
oHI	alarm event disconnects compensation steps	oFF	on / oFF
otA	alarm for high ambient temperature	oFF	on / oFF
tEA	temperature level for alarm	55	10 ... 80°C
ttE	minimum event duration for an alarm activation	0	0 ... 900 s
otE	alarm event disconnects compensation steps	oFF	on / oFF
rSA	alarm for exceeding of maximum number of step closing	oFF	on / oFF
tEV	temperature level for ventilator start	35	10 ... 80°C
Id	device ID number in RS485 network	0	0 ... 255
bAu	communication speed for data transmission	0	0 ... 38,4 kBd
PAr	communication control by parity checking	oFF	oFF / on / on_o
Man	manual mode activation		
Cod	password for access to SET mode	000	any three digits number 001 ... 999
rES	reset to the factory setting	-	

Table 3. Configuration menu

Note

Overdrive is activated by permanent pressing of button ▲ or ▼.

6.1. Target $\cos\phi$ setting (CoS)

Press the button **SET** at least for 5 second for entering service mode. On the display will appear parameter symbol **CoS**. After another pressing of button **SET** display will show set value. Via buttons **▲**, **▼** set new requested value in the limits from 0,8 inductive to 0,8 capacitive. Another pressing of button **SET** saves new value to the memory and on display it will appear again symbol **CoS**.

6.2. Current transformer ratio setting (ltr)

If service mode is activated, move by buttons **▲**, **▼** to the parameter **ltr**. After pressing button **SET**, the set value will appear on the display. Via buttons **▲**, **▼** is possible to change value of transformer ratio. Another press of button **SET** saves new value to the memory and on display, symbol **ltr** will appear again.

It is important to have in mind that the value which is set, is ratio itself. It means that, for example, if primary nominal current of transformer is 50 A and secondary is 5 A then set parameter value is **ltr** = 10.



Caution

Measurement range of the current inputs is from 5 mA to 6 A. Maximum of the adjustable current transformer ratio is 5000 / 5 A. If the secondary current value rises over 5,3 A, alarm will start, in the case it is enabled.

6.3. Automatic detection of compensation stages (Aut)

Another parameter in the menu is function **Aut**. After pressing of button **SET**, the display will show **off**. Via buttons **▲**, **▼** change to the value **on**. After the pressing of button **SET** automatic detection will start to detect connected stages. The symbol **Con** will appear on the display, and first capacitor stage will be switched on and off 6 times in the cycle of 20 seconds.

Detection of controller connection to the system is followed by detection of power of connected capacitor stages. During detection, the measured values of each stage are shown on the display. Measured values are being rounded on 0,5 kvar. After the detection is finished, the regulator will switch parameter **Aut** back to **off**.



Important

*In some cases controller is not able to make automatic detection and in place of measured power shows zeros. It can happen in places with very fast changes of network parameters, where measured values will not be correct. In this case regulator shows **Er1** and it is necessary to set parameters manually, after detailed network measurements.*

6.4. Deceleration of regulation at over compensation (Sht)

This parameter is represented by symbol **Sht**. This function is used for slowing down the regulation during over-compensation. At under-compensation regulation is slowed down according to average power factor. This function assures reduction of switch on/off operation of contactor stages. After pressing the button **SET**, display will show set value of deceleration. By buttons **▲**, **▼** it is possible to change value and button **SET** saves this into the memory. Current situation of regulation deceleration during over-compensation is shown under parameter **Sht**, in the menu of measured values.

6.5. Manual setting of compensation stages (StP)

Entering the parameter **StP** by pressing button **SET** will open sub menu, where it is necessary to select the step, which is going to be set by capacitor power value. Via buttons **▲**, **▼** select the appropriate step. The step is signalized by green LED of the step number. By pressing button **SET** the value of the step will appear on display. Via buttons **▲**, **▼** change the value (LED ind and LED cap inform about definition of the capacitor or de-compensation reactor operated by controller output) and confirm it by button **SET**. Via buttons **▲**, **▼** select another step and follow the same procedure until all steps are set. After setting of all steps, keep pressing button **SET** until display will show **StP** and all step LED's will be off.

Maximum value of the step is 999 kVAR of inductive and capacitive type. Since the display has only three segments to show the values up to 99,9 kVAR are shown with one decimal place. Values over 100 kVAR are shown as a integer although step is still in 0,1 kVAR.

For activation of de-compensation steps study the parameter **EIC**.

6.6. Discharging time (dit)

For setting the absorption of steps, parameter **dit** is available in the menu. By this parameter, it is possible to set, for each step separately, suitable time for capacitor discharge. Discharging time can be set from 5 to 900 seconds. Default factory setting value is 30 seconds.

6.7. Delay for disconnection (diP)

This parameter is represented on the display by symbol **diP**. It is the minimum time for contactor step operation. If during this time the request for disconnection of the step comes the step will not be disconnected until the **diP** time is counted down. It is possible to be set from 5 to 900 seconds.

6.8. Fixed capacitor stages (FSt)

On the display it is represented by symbol **FSt**. This parameter allows to set steps as a fixed ones. The regulator is not counting those steps for regulation cycle. Each step can stay in three working modes.

- **Aut** – stage is normally regulated by controller
- **oFF** – always off (status indication LED blinks red)
- **on** – always on (status indication LED blinks green)

6.9. Connection configuration (Con)

Parameter **Con** defines mutual position between voltage and current measuring circuits in the three-phase network. According to controller supply and measuring voltage variant the correction angle differs.

Table 4 shows all possible combination and its correction angles of voltage and current measuring circuits for 400V variant of controllers FCR05 and FCR07.

Current transformer location and position		Line voltage					
		L1 (4) - L2 (3)	L2 (4) - L1 (3)	L2 (4) - L3 (3)	L3 (4) - L2 (3)	L3 (4) - L1 (3)	L1 (4) - L3 (3)
L1	k (2) - l (1)	210°	30°	90°	270°	330°	150°
	l (1) - k (2)	30°	210°	270°	90°	150°	330°
L2	k (2) - l (1)	330°	150°	210°	30°	90°	270°
	l (1) - k (2)	150°	330°	30°	210°	270°	90°
L3	k (2) - l (1)	90°	270°	330°	150°	210°	30°
	l (1) - k (2)	270°	90°	150°	330°	30°	210°

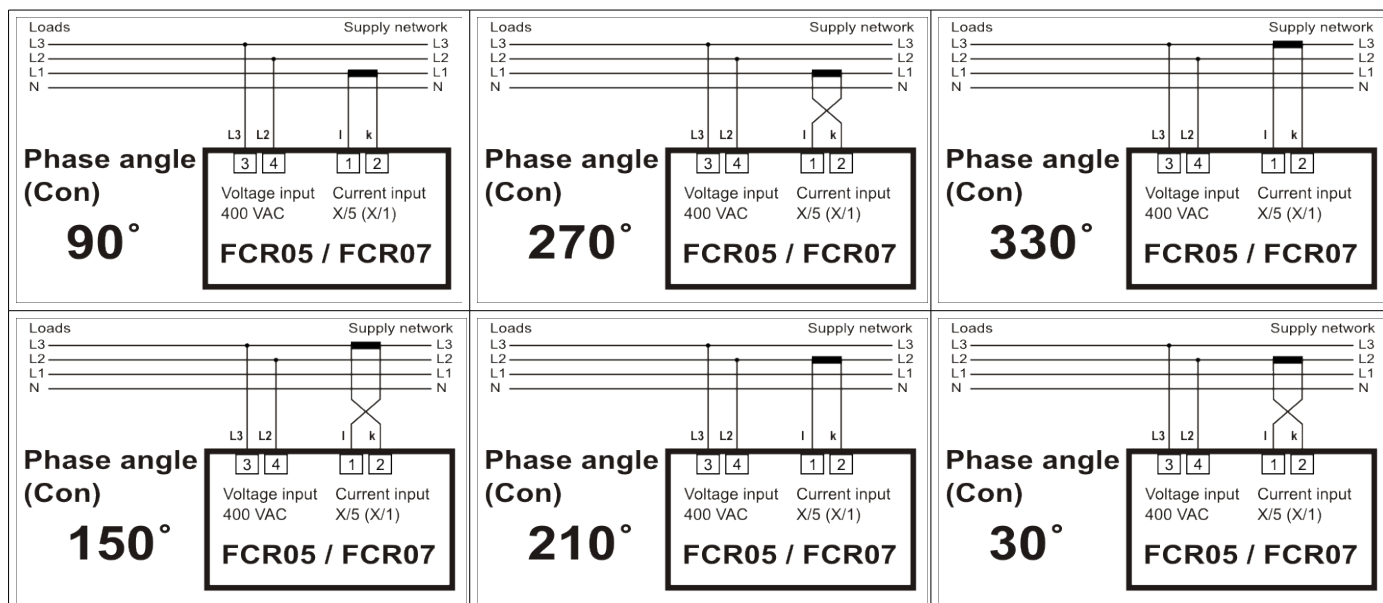

Table 4. Phase shift setting for supply and measuring voltage 400 V AC

Table 5 shows all possible combinations of voltage and current measuring circuits for 230V connection of FCR05V230 and FCR07V230 controller variant.

Current transformer location and position		Phase voltage					
		L1 (4) - N (3)	N (4) - L1 (3)	L2 (4) - N (3)	N (4) - L2 (3)	L3 (4) - N (3)	N (4) - L3 (3)
L1	k (2) - I (1)	180°	0°	60°	240°	300°	120°
	I (2) - k (1)	0°	180°	240°	60°	120°	300°
L2	k (2) - I (1)	300°	120°	180°	0°	60°	240°
	I (2) - k (1)	120°	300°	0°	180°	240°	60°
L3	k (2) - I (1)	60°	240°	300°	120°	180°	0°
	I (2) - k (1)	240°	60°	120°	300°	0°	180°

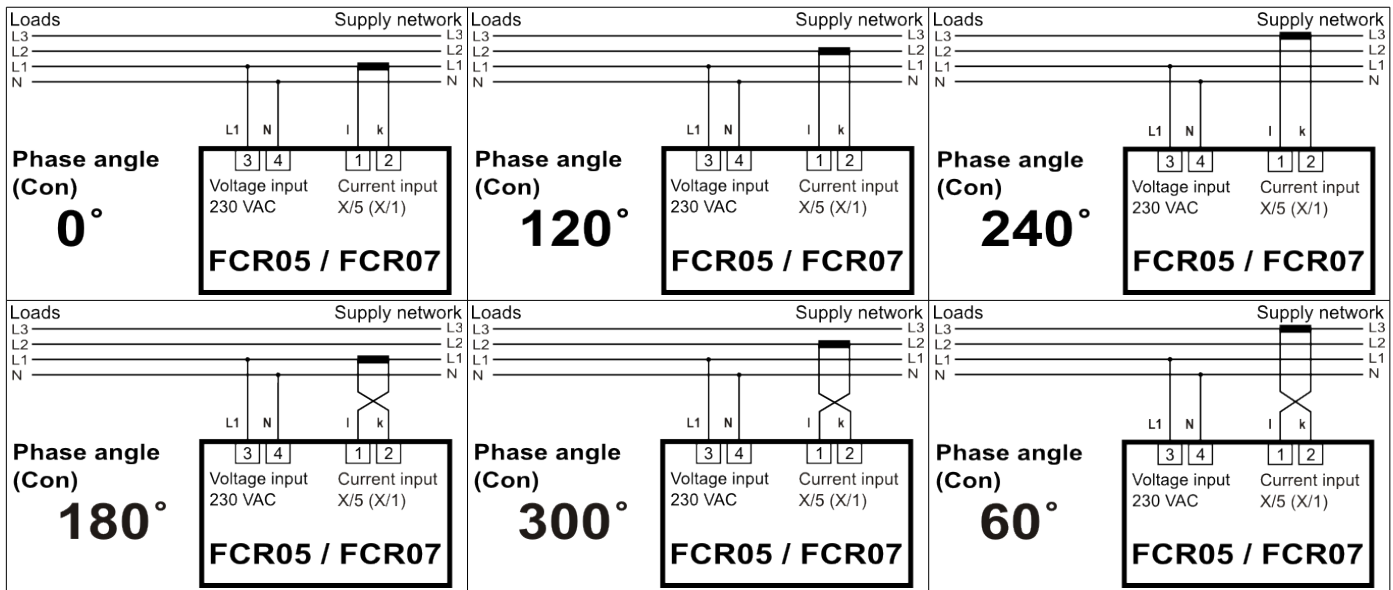

Table 5. Phase shift setting for supply and measuring voltage 230 V AC

6.10. Regulation to average or instantaneous power factor (_CS)

This setting defines if regulator will regulate slow contactor stages to average or instantaneous power factor. If the set value is **on** then usage of contactor stages is affected by average power factor. If the set value is **off** then regulation is performed only according to instantaneous power factor. In configuration mode move via button **▲**, **▼** to the item **_CS**. After pressing of button **SET** display will show set value **on** / **off** / **Aut**. Via buttons **▲**, **▼** it is possible to change this value. Another pressing of button **SET** saves new value into the regulator memory.



Caution

Option **Aut** is a modification for Lithuanian market where there is not defined any area for $\cos\varphi$ (for example 0,96 ... 1) but strict limit $\cos\varphi = 1$. With enabled option **Aut**, controller is regulating symmetrically according to parameter **SHt**.

6.11. Averaging time for APFR (tAC)

This setting defines half-period of average $\cos\varphi$ calculation. There are available four times for average $\cos\varphi$ calculation (15, 30, 45 and 60 minutes). Default value of period for average $\cos\varphi$ calculation is 30 minutes which refers to half-period set from factory on 15 minutes. It is suitable for most of applications.

After entering selected parameter currently set value of time period will appear. Via buttons **▲**, **▼** it is possible to change this value. Another pressing of button **SET** saves new value into the regulator memory.

6.12. Recording of number of operations and maximum values (CSt)

Activation of this parameters allows the controller to save maximums (the minimum value of frequency is being recorded as well) of measured values into internal memory.

Monitoring of measured parameters is being done in real time but recording to non volatile memory is done 3 times per 24 hours. Before recording the maximum (minimum) into the memory, this value is kept in standard operating memory. In the case that power supply is lost before recording to non volatile memory the maximum (minimum) values will be lost.

6.13. De-compensation steps settings (EIC)

For application where there is a need of de-compensation by reactors it is necessary enable inductive steps setting in parameter **EIC**. If the parameter is set on yes then particular step powers can be set in inductive or capacitive power.

De-compensation by reactor steps is possible be done in two solutions. For application where there is only capacitive load the all steps may be based on de-compensation reactors. For application where there is inductive load which time to time turns to capacitive load the only compensation one step of controller can be based on de-compensation reactor and rest of steps can be based on capacitors. This case the appropriate de-compensation power will be tuned by combination of de-compensation reactor and capacitor steps.

6.14. Alarms

To allowed controller FCR05 or FCR07 to use last step as an alarm output the last step power (6th for FCR05 or 8th for FCR07) has to be set on 0. If it is set for some power value the alarm will be just informative without action on last step of controller.

During normal operation alarm output is opened. If there is activated an alarm by an event the alarm output will switch on.

Individual events, which activate alarm event can be defined in setting mode by four particular settings. Each alarm event that is requested has to be enabled at first. After that the value of trigger that activated alarm has to be set and also duration of event presence. Last setting option is an alarm event influence on disconnection of compensation outputs.

Following table shows a list of available alarm events.

Code	Description
ULA	Under-voltage alarm
UHA	Over-voltage alarm
ILA	Low-current alarm
IHA	Over-current alarm
CoA	Under compensation alarm
HuA	THDU alarm
HIA	THDI alarm
otA	Temperature alarm
rSA	Alarm from maximum allowed step connection



Note

Alarm output is switched on for 1 minute. After that it is switched off.

Temperature alarm is a special alarm which behaves in two levels. If this alarm is activated, alarm output contact is used for ventilator control and cannot be used for any other alarm event indication. Output contact closes when temperature measured by controller goes over level set in parameter **tEV**. In this case, all alarm events are only shown on the display without output contact action. Second level which disconnects all compensation stages and gives alarm event on display is defined by parameter **tEA**.



Caution

*If the **otA** alarm is enabled then alarm output is used for ventilator control. All other alarms are then only informative without feedback on the alarm output.*

6.15. Configuration of RS485 communication port

Following parameters relate to configuration of serial communication for RS485 port (MODBUS communication protocol).

- **Id** – defines the number of device in the RS485 network and can be set from 1 ... 255
- **bAU** – defines communication speed between the FCR controller and PC. Default value is 0.
- **PAr** – by default it is set to **oFF** and it can be changed to even (**on**) or odd (**on_o**)

6.16. Password for entering configuration mode (Cod)

Thanks to password is possible to protect regulator against unauthorized configuration. Without proper password knowledge it is possible only see set parameters but not to change them. Password is set as four digit number. In configuration mode move via buttons ▲, ▼ to the parameter **Cod**. After pressing of button **SET** display will show “- - -”. First dash from left side is blinking. Via button ▲ set number from 0 ... 9 and confirm by button ▼. Now second dash is blinking and first set number lights on the display. Keep the same procedure until last number is set. By pressing of button **SET**, password for entering configuration mode is saved into the memory. From this moment it is necessary, for each change, type password in order to enter configuration mode. Otherwise any change will not be accepted.

Password protection can be deactivated by the same way as password activating but by entering the code “000”.

6.17. Restart (rES)

This function restores default configuration. It is last item in the menu and it is represented on the display by symbol **rES**. Press the button **SET** and keep it. At the same time press the button ▼. LED of capacitor stages will turn on and then slowly will start to go down. This cycle will repeat two times. After that, the display will show instantaneous value of power factor. Factory setting will be restored.



Important

After restart, it is necessary to set device again or perform auto detection.

7. Displayed values

Value choice, which will be shown on the display is independent on the operation of the regulator itself. It is possible to change it at any time. LED on the right side of display identifies sort of shown value.

Shown values are sorted to levels so that values in one level are closely related. For switching between particular levels use button ▲ and for changing screens within one level use button ▼. Splitting of shown values to the levels is clear from following list. For returning to the instantaneous $\cos\phi$ represented by symbol **CoS** press button **SET**.

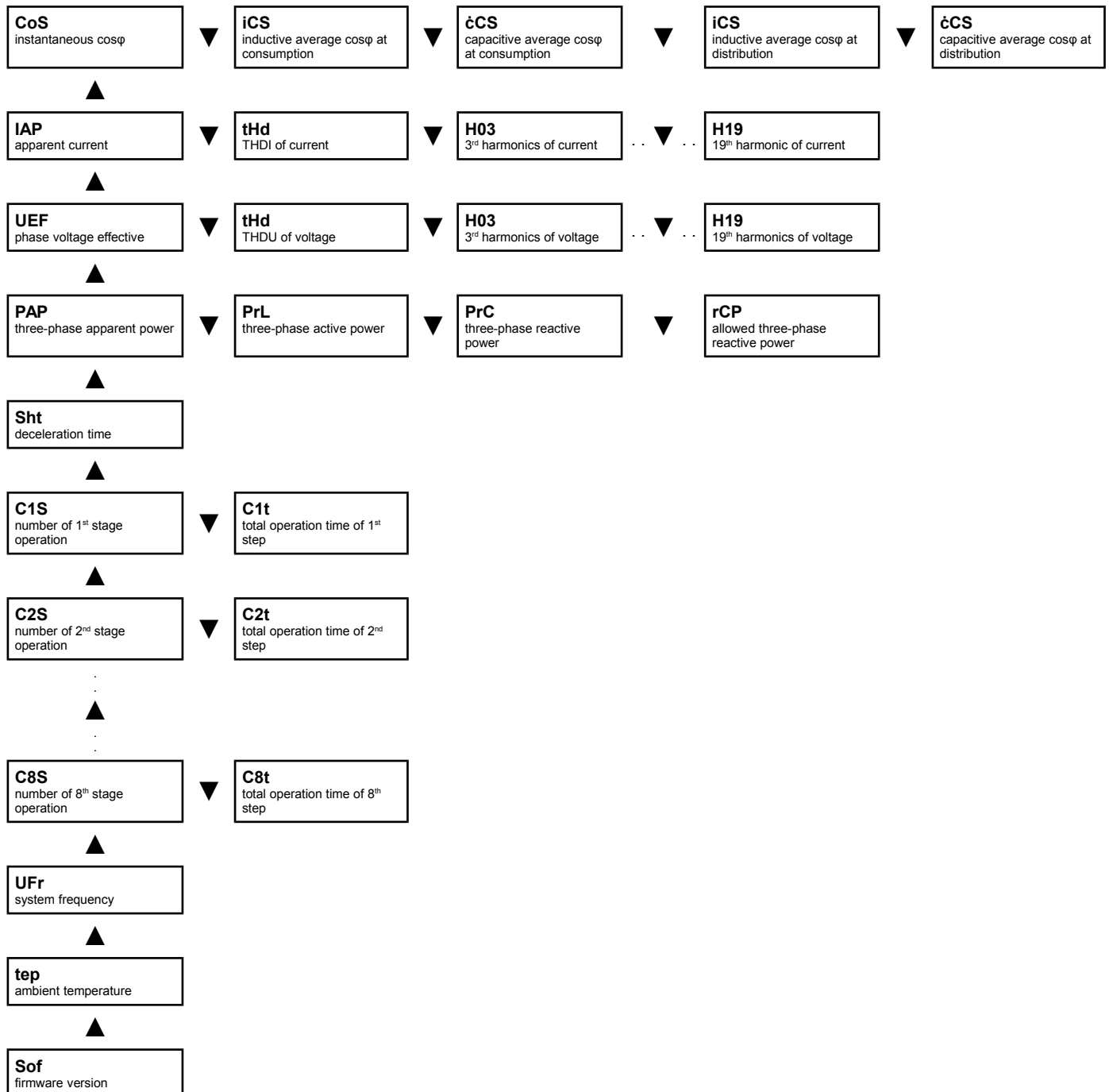

7.1. Cosφ

Displaying the $\cos\phi$ is default indication. This value will appear on display after supply voltage connection and if in current input the current flow is ≥ 5 mA. Red LED on the left side of display marked as **ind** and **cap** indicates if

measured power factor is in inductive or capacitive area. If measuring current drops below 5 mA, then regulator disconnects all stages and on the display will appear "-- --".

By button ► it is possible move to average inductive power factor indication. At first, the display will show symbol **iCS** and then after 1 second numeric value will be shown. Following the same procedure it is possible to move to average capacitive power factor represented by symbol **ĉCS**.

7.2. Apparent current

Pressing of button ▲ will move to another level - apparent current. Symbol **IAP** will appear on the display for 1 second. After that, the display will show effective value of apparent current on primary side of current transformer, assuming that correct transformer ratio is set in configuration mode, under the parameter **ltr**.

Another value in this level is current harmonic distortion factor. After pressing the button ►, the display will show symbol **tHd**, which will be replaced after 1 second by actual measured value. For getting information about maximum value or erasing it, follow the same procedure as described above.

7.3. Voltage

This level is exactly the same as previous level, but for line voltage.

7.4. Powers

Monitoring level of power show following information about three-phase powers.

PAP – three phase apparent power in kVA

PrL – three phase active power in kW

PLC – three-phase reactive power in kVAr

rCP – allowed reactive power for the reached $\cos\varphi$ in kVAr

7.5. De-compensation delay

This parameter **Sht** shows actual remaining time (seconds) to regulation action during over-compensation. Displayed value is decreased each second by square of true control deviation and requested power factor value.

7.6. Step operation number and time

Number of step operations is divided to the 6 for FCR05 (8 for FCR07) independent levels. For the first step, the display will show symbol **C1S** and after it disappears the number of first step operation number will be displayed. By pressing the button ▼ the symbol **C1t** will show and after this the total time of usage of the step will be shown. The time is in hours.

By simultaneous pressing of buttons ▼ and **SET** this information can be erased.

8. Manual operation

Switching the regulator to the service mode and entering the parameter **Man** will activate the manual regulation of compensation steps. On the display, symbol **St1** will be shown for 1 second. After that, it will be replaced by actual value, which blinking (manual mode indication). Button ▲ allows to change stage status with respecting the set discharging time and delay for stage disconnection. It means that if the stage was disconnected, pressing the button ▲ will switch the stage on. If the stage was connected, the same button will switch the stage off. For another stage selection press button ▼. After pressing this button, the display will show for 1 second symbol **St2**, representing another stage. The whole procedure is the same like for the previous stage. By pressing the button **SET**, manual mode can be deactivated.

9. Alarm notification

If at least one of enabled alarm events appeared, then alarm output relay No. 6 for FCR05 (output relay No. 8 for FCR07) will be switched on for 1 minute and LED with label **alarm** will blink on the display. This LED will also blink after the alarm event disappears, until it gets cancelled by button **SET**. Alarm notification doesn't have any influence to regulator behaviour.

The symbol of alarm sort is shown on the display after pressing of button **SET**. Symbol of the event that caused the alarm will appear on the display. Another pressing the button **SET** will cancel shown alarm. If more alarm events happened, another event symbol will appear on the display. By keeping the same procedure, it is possible to follow till last alarm event is not cancelled. In the displayed values mode it is possible to find out which values of alarm events activated alarm. Alarm event symbols are the same as symbols used during alarm setting in service mode.

10. Technical features

Parameter	Value
Supply voltage / measuring voltage	400 V AC (+10%,-15%) 230 V AC (+10%,-15%)
Frequency	50 / 60 Hz
Current range	0,005 ... 6 A
Measurement accuracy of current input	± 0,2%
Measurement accuracy of voltage input	± 0,5%
THDU and THDI accuracy	(U>10%Un) ±5% / (I>10%In) ±5%
Phase error for I > 3% In	± 3° (otherwise ±1°)
Power consumption	< 3,2 VA
Output channels number	6 or 8
Switching power of alarm output	250 VAC / 5 A
Switching power of relay contacts	250 VAC / 5 A
Range of targeted power factor	0,8 ind. ... 0,8 cap.
Range of adjustable step reactive power	999 kVAr ind. 999 kVAr cap.
Re-connection delay of step	5 ... 900 s
Switching off delay of step	5 ... 900 s
Compensation steps value setting	manually / automatically
Communication port	RS485 (optional)
Communication protocol	MODBUS RTU
Communication speed	9600 ... 38400 Bd
Temperature limit	-40°C ... +70°C
Front panel	97 mm x 97 mm (5 DIN modules for FCR05DL/07DL)
Panel cutout	91 mm x 91 mm
Site depth	55 mm
Weight	0,65 kg (including packaging)
Protection degree	IP20 rear cover / IP54 front panel
Standards	EN 61010-1, EN50081-1, EN50082-1