

# ***CHAPTER 1***

## ***GENERAL INFORMATION***

Model Identification .....	1.1
Serial Number Location .....	1.1
Specifications - General .....	1.2
Publication Numbers .....	1.3
Paint Codes .....	1.3
Standard Torque Specifications .....	1.4
Lubricant and Maintenance Part Numbers .....	1.4
Torque Conversion Table .....	1.5-1.6
Decimal Equivalent Chart .....	1.7
Unit of Measure Conversion Table .....	1.8
Tap Drill Charts .....	1.9
Glossary of Terms .....	1.10-1.11
Inspection Schedule .....	1.12
Vehicle Inspection .....	1.13-1.15
Transmission Lubrication .....	1.16
Throttle Operation / Air Screw Adjustment .....	1.17
Idle Speed Adjustment .....	1.18
Throttle Cable Adjustment .....	1.18-1.19
Oil Pump Adjustment / Bleeding .....	1.20
Oil Pump Troubleshooting .....	1.21
Fuel System .....	1.22-1.23
Compression Test .....	1.24
Air Filter Service .....	1.24
Wheels and Tires .....	1.25-1.26
Alignment .....	1.27-1.28



## **MODEL IDENTIFICATION**

The machine model number must be used with any correspondence regarding warranty or service.

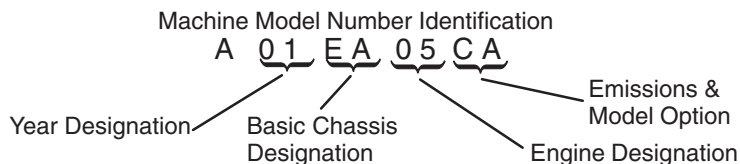

## **VIN IDENTIFICATION**

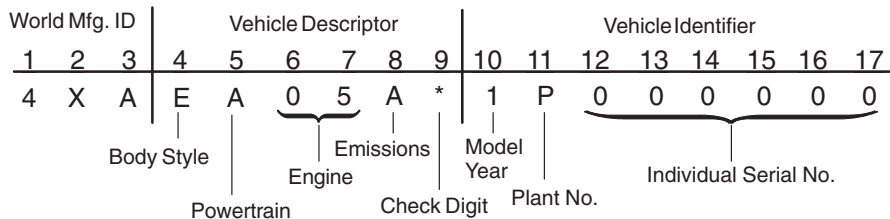

\* This could be either a number or a letter

## **ENGINE SERIAL NUMBER LOCATION**

Whenever corresponding about an engine, be sure to refer to the engine model number and serial number. This information can be found stamped on the transmission section located by the transmission oil fill plug(A).

## **MACHINE SERIAL NUMBER LOCATION**

The machine model number and serial number are important for vehicle identification. The machine serial number is stamped on the front of the frame tube(B).

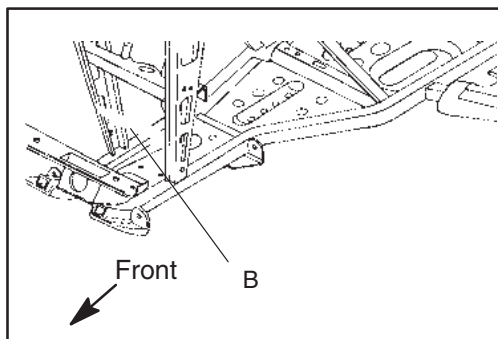
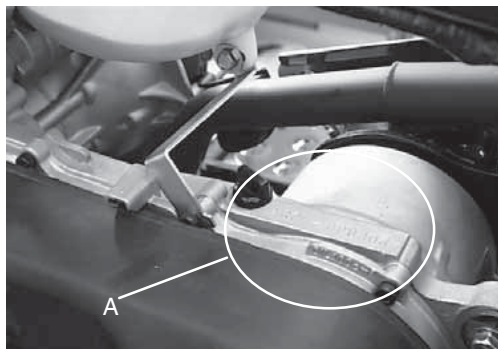

## GENERAL INFORMATION

### SPECIFICATIONS

MODEL	SCRAMBLER 50	SCRAMBLER 90	SPORTSMAN 90
ENGINE TYPE	2-Stroke Horizontal	2-Stroke Horizontal	2-Stroke Horizontal
NUMBER OF CYLINDERS	1	1	1
DISPLACEMENT	49.3 cc	89.2 cc	89.2 cc
BORE AND STROKE	1.58x1.54" (40x39.2 mm)	2.05x1.65" (52x42 mm)	2.05x1.65" (52x42 mm)
COMPRESSION RATIO	6.8:1	5.8:1	5.8:1
ALTERNATOR OUTPUT	70 Watts @ 4000 RPM	70 Watts @ 4000 RPM	70 Watts @ 4000 RPM
IGNITION TIMING	14° @ 1500 RPM	16° @ 1500 RPM	16° @ 1500 RPM
MAX. TORQUE	4 ft.lbs (5.4 Nm) @ 6000 RPM	6.5 ft.lbs (8.82 Nm) @ 6000 RPM	6.5 ft.lbs (8.82 Nm) @ 6000 RPM
CARBURETOR	Mikuni AM3 with automatic choke	Mikuni AM7 with automatic choke	Mikuni AM7 with automatic choke
STARTING	Electric/Kick Start	Electric/Kick Start	Electric/Kick Start
BATTERY	12N4-3B, 4 milliamp	12N4-3B, 4 milliamp	12N4-3B, 4 milliamp
LUBRICATION	Oil Injection	Oil Injection	Oil Injection
OIL CAPACITY	1.057 Quarts (1 Liter)	1.057 Quarts (1 Liter)	1.057 Quarts (1 Liter)
TRANSMISSION	Automatic (C.V.T. System)	Automatic (C.V.T. System)	Automatic (C.V.T. System)
FRONT SUSPENSION	A-arm with 2" (5 cm) Travel	A-arm with 2" (5 cm) Travel	A-arm with 2" (5 cm) Travel
REAR SUSPENSION	Single Shock/Swing Arm with 2" (5 cm) Travel	Single Shock/Swing Arm with 2" (5 cm) Travel	Single Shock/Swing Arm with 2" (5 cm) Travel
FRONT BRAKE	Drum	Drum	Drum
REAR BRAKE	Drum	Drum	Drum
PARKING BRAKE	Mechanical Lock	Mechanical Lock	Mechanical Lock
FRONT TIRES	16x8-7	18x7-7	19x7-8
REAR TIRES	16x8-7	18x7-7	18x9.5-8
TIRE PRESSURE	2 psi	2 psi	2 psi
OVERALL DIMENSIONS	54x34x34.7" (137.1x86.4x88.1 cm)	56.1x34x36.1" (142.4x86.3x91.8 cm)	57.6x34.4x36.6" (146.3x87.4x93 cm)
WHEELBASE	35.4" (90 cm)	35.4" (90 cm)	37.8" (96 cm)
TURNING RADIUS	74.8" (190 cm)	98.4" (250 cm)	98.4" (250 cm)
SEAT HEIGHT	22.5" (57 cm)	24.5" (62 cm)	24.5" (62 cm)
GROUND CLEARANCE	3" (8 cm)	4" (10 cm)	5" (12 cm)
DRY WEIGHT	211.6 lbs. (96 kg)	233.7 lbs. (106 kg)	238.1 lbs. (108 kg)
MAX. LOAD	100 lbs. (45.4 kg)	160 lbs. (72 kg)	190 lbs. (86 kg)
FUEL REQUIREMENTS	87 Octane Unleaded	87 Octane Unleaded	87 Octane Unleaded
FUEL CAPACITY	1.32 Gallons (5 Liters)	1.32 Gallons (5 Liters)	1.32 Gallons (5 Liters)
FRONT RACK CAPACITY	N/A	N/A	10 lbs. (4.54 kg)*
REAR RACK CAPACITY	N/A	N/A	20 lbs. (9.08 kg)*

\* Check owner's manual for loading requirements and restrictions.

**PUBLICATION NUMBERS**

Year	Model	Model No.	Owner's Manual PN	Parts Manual PN	Parts Micro Fiche PN	Service Manual
2001	Scrambler 50	A01EA05CA	9916424	9916426	9916427	9916576
2001	Sportsman 90	A01FA09CA	9916424	9916762	9916763	9916576
2001	Scrambler 90	A01EA09CA	9916424	9916432	9916433	9916576

When ordering service parts be sure to use the correct parts manual.

**PAINT CODES**

PAINTED PART	COLOR DESCRIPTION	DITZLER NUMBER	POLARIS NUMBER
2001 Scrambler 50 Springs	Fire Red	72060	P-093
2001 Sportsman 90 Springs	Fire Red	72060	P-093
2001 Scrambler 90 Springs	Fire Red	72060	P-093

FRAME COLOR - (All) P067 Medium Gloss Black 9440 / 8520147.

Order direct from Midwest Industrial Coatings (763-942-1840). Mix as directed.

## GENERAL INFORMATION

### STANDARD TORQUE SPECIFICATIONS

The following torque specifications are to be used as a general guideline. There are exceptions in the steering, suspension, and engine areas. Always consult the exploded views in each manual section for torque values of fasteners before using standard torque.

FASTENER	TORQUE (ft.lbs. / in.lbs.)	TORQUE (Nm)
5 mm bolts and nuts	39-52 in.lbs.	4.5-6 Nm
6 mm bolts and nuts	69-104 in.lbs.	8-12 Nm
8 mm bolts and nuts	13-18 ft.lbs.	18-25 Nm
10 mm bolts and nuts	22-29 ft.lbs.	30-40 Nm
12 mm bolts and nuts	36-43 ft.lbs.	50-60 Nm
4 mm screws	22-30 in.lbs.	2.5-3.4 Nm
5 mm screws	30-43 in.lbs.	3.5-5 Nm
6 mm Hex bolts	87-121 in.lbs.	10-14 Nm
8 mm Hex bolts	17-22 ft.lbs.	24-30 Nm
10 mm Hex bolts	25-32 ft.lbs.	35-45 Nm

### POLARIS PREMIUM LUBRICANT AND MAINTENANCE PRODUCT PART NUMBERS

Part No.	Description
<b>Engine Lubricant</b>	
2870791	Fogging Oil
2871098	Premium 2 Cycle Engine Oil (Quart)
2871097	Premium 2 Cycle Engine Oil (Gallon)
2871240	Premium 2 Cycle Engine Oil (2.5 Gallon)
2871566	Premium 2 Cycle Engine Oil (16 Gallon)
2871385	Premium 2 Cycle Engine Oil (30 Gallon)
2871240	Premium 2 Cycle Engine Oil (55 Gallon)
2871721	Premium Gold 2 Cycle Synthetic Lubricant (Quart)
2871722	Premium Gold 2 Cycle Synthetic Lubricant (Gallon)
<b>Gearcase / Transmission Lubricants</b>	
2871477	Premium Synthetic Gearcase Lubricant (1 Gal.)
2871478	Premium Synthetic Gearcase Lubricant (12 oz.. bottle)
2870465	Oil Pump for Gearcase Oil
<b>Grease / Specialized Lubricants</b>	
2871322	Premium All Season Grease (3 oz.. cartridge)
2871423	Premium All Season Grease (14 oz.. cartridge)
2871460	Starter Drive Grease
2871312	Grease Gun Kit
2871329	Nyogel™ Grease
<b>Additives / Sealants / Thread Locking Agents / Misc.</b>	
2871326	Premium Carbon Clean 12 oz..
2870652	Fuel Stabilizer 16 oz..

## TORQUE CONVERSIONS

## Newton Meter to Pound Foot and Pound Inch

Nm	lb ft	lb in	Nm	lb ft	Nm	lb ft
1	0.74	8.65	49	36.14	97	71.55
2	1.48	17.30	50	36.88	98	72.28
3	2.21	25.95	51	37.62	99	73.02
4	2.95	34.60	52	38.36	100	73.76
5	3.69	43.26	53	39.09	101	74.50
6	4.43	51.91	54	39.83	102	75.24
7	5.16	60.56	55	40.57	103	75.97
8	5.90	69.21	56	41.31	104	76.71
9	6.64	77.86	57	42.04	105	77.45
10	7.38	86.51	58	42.78	106	78.19
11	8.11	95.16	59	43.52	107	78.92
12	8.85	103.81	60	44.26	108	79.66
13	9.59	112.46	61	44.99	109	80.40
14	10.33	121.11	62	45.73	110	81.14
15	11.06		63	46.47	111	81.87
16	11.80		64	47.21	112	82.61
17	12.54		65	47.94	113	83.35
18	13.28		66	48.68	114	84.09
19	14.01		67	49.42	115	84.82
20	14.75		68	50.16	116	85.56
21	15.49		69	50.89	117	86.30
22	16.23		70	51.63	118	87.04
23	16.96		71	52.37	119	87.77
24	17.70		72	53.11	120	88.51
25	18.44		73	53.84	121	89.25
26	19.18		74	54.58	122	89.99
27	19.92		75	55.32	123	90.72
28	20.65		76	56.06	124	91.46
29	21.39		77	56.80	125	92.20
30	22.13		78	57.53	126	92.94
31	22.87		79	58.27	127	93.68
32	23.60		80	59.01	128	94.41
33	24.34		81	59.75	129	95.15
34	25.08		82	60.48	130	95.89
35	25.82		83	61.22	131	96.63
36	26.55		84	61.96	132	97.36
37	27.29		85	62.70	133	98.10
38	28.03		86	63.43	134	98.84
39	28.77		87	64.17	135	99.58
40	29.50		88	64.91	136	100.31
41	30.24		89	65.65	137	101.05
42	30.98		90	66.38	138	101.79
43	31.72		91	67.12	139	102.53
44	32.45		92	67.86	140	103.26
45	33.19		93	68.60	141	104.00
46	33.93		94	69.33	142	104.74
47	34.67		95	70.07	143	105.48
48	35.40		96	70.81	144	106.21

**TORQUE CONVERSIONS**

**Newton Meter to Pound Foot and Pound Inch**

<b>Nm</b>	<b>lb ft</b>
145	106.95
146	107.69
147	108.43
148	109.16
149	109.90
150	110.64
151	111.38
152	112.12
153	112.85
154	113.59
155	114.33
156	115.07
157	115.80
158	116.54
159	117.28
160	118.02
161	118.75
162	119.49
163	120.23
164	120.97
165	121.70
166	122.44
167	123.18
168	123.92
169	124.65
170	125.39
171	126.13
172	126.87
173	127.60
174	128.34
175	129.08
176	129.82
177	130.56
178	131.29
179	132.03
180	132.77
181	133.51
182	134.24
183	134.98
184	135.72
185	136.46
186	137.19
187	137.93
188	138.67
189	139.41

<b>Nm</b>	<b>lb ft</b>
190	140.14
191	140.88
192	141.62
193	142.36
194	143.09
195	143.83
196	144.57
197	145.31
198	146.04
199	146.78
200	147.52
201	148.26
202	149.00
203	149.73
204	150.47
205	151.21
206	151.95
207	152.68
208	153.42
209	154.16
210	154.90
211	155.63
212	156.37
213	157.11
214	157.85
215	158.58
216	159.32
217	160.06
218	160.80
219	161.53
220	162.27
221	163.01
222	163.75
223	164.48
224	165.22
225	165.96
226	166.70
227	167.44
228	168.17
229	168.91
230	169.65
231	170.39
232	171.12
233	171.86
234	172.60

<b>Nm</b>	<b>lb ft</b>
235	173.34
236	174.07
237	174.81
238	175.55
239	176.29
240	177.02
241	177.76
242	178.50
243	179.24
244	179.97
245	180.71
246	181.45
247	182.19
248	182.92
249	183.66
250	184.40
251	185.14
252	185.88
253	186.61
254	187.35
255	188.09
256	188.83
257	189.56
258	190.30
259	191.04
260	191.78
261	192.51
262	193.25
263	193.99
264	194.73
265	195.46
266	196.20
267	196.94
268	197.68
269	198.41
270	199.15
271	199.89
272	200.63



**DECIMAL EQUIVALENTS**

1/64	.....	.0156	
1/32	.....	.0312	1 mm = .0394"
3/64	.....	.0469	
1/16	.....	.0625	
5/64	.....	.0781	2 mm = .0787"
3/32	.....	.0938	
7/64	.....	.1094	3 mm = .1181"
1/8	.....	.1250	
9/64	.....	.1406	
5/32	.....	.1563	4 mm = .1575"
11/64	.....	.1719	
3/16	.....	.1875	5 mm = .1969"
13/64	.....	.2031	
7/32	.....	.2188	
15/64	.....	.2344	6 mm = .2362"
1/4	.....	.25	
17/64	.....	.2656	7 mm = .2756"
9/32	.....	.2813	
19/64	.....	.2969	
5/16	.....	.3125	8 mm = .3150"
21/64	.....	.3281	
11/32	.....	.3438	9 mm = .3543"
23/64	.....	.3594	
3/8	.....	.375	
25/64	.....	.3906	10 mm = .3937"
13/32	.....	.4063	
27/64	.....	.4219	11 mm = .4331"
7/16	.....	.4375	
29/64	.....	.4531	
15/32	.....	.4688	12 mm = .4724"
31/64	.....	.4844	
1/2	.....	.5	13 mm = .5118
33/64	.....	.5156	
17/32	.....	.5313	
35/64	.....	.5469	14 mm = .5512"
9/16	.....	.5625	
37/64	.....	.5781	15 mm = .5906"
19/32	.....	.5938	
39/64	.....	.6094	
5/8	.....	.625	16 mm = .6299"
41/64	.....	.6406	
21/32	.....	.6563	17 mm = .6693"
43/64	.....	.6719	
11/16	.....	.6875	
45/64	.....	.7031	18 mm = .7087"
23/32	.....	.7188	
47/64	.....	.7344	19 mm = .7480"
3/4	.....	.75	
49/64	.....	.7656	
25/32	.....	.7813	20 mm = .7874"
51/64	.....	.7969	
13/16	.....	.8125	21 mm = .8268"
53/64	.....	.8281	
27/32	.....	.8438	
55/64	.....	.8594	22 mm = .8661"
7/8	.....	.875	
57/64	.....	.8906	23 mm = .9055"
29/32	.....	.9063	
59/64	.....	.9219	
15/16	.....	.9375	24 mm = .9449"
61/64	.....	.9531	
31/32	.....	.9688	25 mm = .9843
63/64	.....	.9844	
1	.....	1.0	

**CONVERSION TABLE**

Unit of Measure	Multiplied by	Converts to
ft. lbs.	x 12	= in. lbs.
in. lbs.	x .0833	= ft. lbs.
ft. lbs.	x 1.356	= Nm
in. lbs.	x .0115	= kg-m
Nm	x .7376	= ft.lbs.
kg-m	x 7.233	= ft. lbs.
kg-m	x 86.796	= in. lbs.
kg-m	x 10	= Nm
in.	x 25.4	=mm
mm	x .03937	= in.
in.	x 2.54	= cm
mile (mi.)	x 1.6	= km
km	x .6214	= mile (mi.)
Ounces (oz)	x 28.35	= Grams (g)
Fluid Ounces (fl. oz.)	x 29.57	= Cubic Centimeters (cc)
Cubic Centimeters (cc)	x .03381	= Fluid Ounces (fl. oz.)
Grams (g)	x 0.035	= Ounces (oz)
lb.	x .454	= kg
kg	x 2.2046	= lb.
Cubic inches (cu in)	x 16.387	= Cubic centimeters (cc)
Cubic centimeters (cc)	x 0.061	= Cubic inches (cu in)
Imperial pints (Imp pt)	x 0.568	= Liters (l)
Liters (l)	x 1.76	= Imperial pints (Imp pt)
Imperial quarts (Imp qt)	x 1.137	= Liters (l)
Liters (l)	x 0.88	= Imperial quarts (Imp qt)
Imperial quarts (Imp qt)	x 1.201	= US quarts (US qt)
US quarts (US qt)	x 0.833	= Imperial quarts (Imp qt)
US quarts (US qt)	x 0.946	= Liters (l)
Liters (l)	x 1.057	= US quarts (US qt)
US gallons (US gal)	x 3.785	=Liters (l)
Liters (l)	x 0.264	= US gallons (US gal)
Pounds - force per square inch (psi)	x 6.895	= Kilopascals (kPa)
Kilopascals (kPa)	x 0.145	= Pounds - force per square inch (psi)
Kilopascals (kPa)	x 0.01	= Kilograms - force per square cm
Kilograms - force per square cm	x 98.1	= Kilopascals (kPa)
$\pi (3.14) \times R^2 \times H$ (height)		= Cylinder Volume

°C to °F:  $9 (°C + 40) \div 5 - 40 = °F$

°F to °C:  $5 (°F + 40) \div 9 - 40 = °C$

**SAE TAP DRILL SIZES**

Thread Size	Drill Size	Thread Size	Drill Size
#0-80	3/64	1/2-13	27/64
#1-64	53	1/2-20	29/64
#1-72	53	9/16-12	31/64
#2-56	51	9/16-18	33/64
#2-64	50	5/8-11	17/32
#3-48	5/64	5/8-18	37/64
#3-56	45	3/4-10	21/32
#4-40	43	3/4-16	11/16
#4-48	42	7/8-9	49/64
#5-40	38	7/8-14	13/16
#5-44	37	1-8	7/8
#6-32	36	1-12	59/64
#6-40	33	1 1/8-7	63/64
#8-32	29	1 1/8-12	1 3/64
#8-36	29	1 1/4-7	1 7/64
#10-24	24	1 1/4-12	1 11/64
#10-32	21	1 1/2-6	1 11/32
#12-24	17	1 1/2-12	1 27/64
#12-28	4.6mm	1 3/4-5	1 9/16
1/4-20	7	1 3/4-12	1 43/64
1/4-28	3	2-4 1/2	1 25/32
5/16-18	F	2-12	1 59/64
5/16-24	I	2 1/4-4 1/2	2 1/32
3/8-16	O	2 1/2-4	2 1/4
3/8-24	Q	2 3/4-4	2 1/2
7/16-14	U	3-4	2 3/4
7/16-20	25/64		

**METRIC TAP DRILL SIZES**

Tap Size	Drill Size	Decimal Equivalent	Nearest Fraction
3 x .50	#39	0.0995	3/32
3 x .60	3/32	0.0937	3/32
4 x .70	#30	0.1285	1/8
4 x .75	1/8	0.125	1/8
5 x .80	#19	0.166	11/64
5 x .90	#20	0.161	5/32
6 x 1.00	#9	0.196	13/64
7 x 1.00	16/64	0.234	15/64
8 x 1.00	J	0.277	9/32
8 x 1.25	17/64	0.265	17/64
9 x 1.00	5/16	0.3125	5/16
9 x 1.25	5/16	0.3125	5/16
10 x 1.25	11/32	0.3437	11/32
10 x 1.50	R	0.339	11/32
11 x 1.50	3/8	0.375	3/8
12 x 1.50	13/32	0.406	13/32
12 x 1.75	13/32	0.406	13/32

### GLOSSARY OF TERMS

**ABDC:** After bottom dead center.

**ACV:** Alternating current voltage.

**Alternator:** Electrical generator producing voltage alternating current.

**ATDC:** After top dead center.

**BBDC:** Before bottom dead center.

**BDC:** Bottom dead center.

**BTDC:** Before top dead center.

**CC:** Cubic centimeters.

**Center Distance:** Distance between center of crankshaft and center of driven clutch shaft.

**Chain Pitch:** Distance between chain link pins (No. 35 = 3/8" or 1 cm). Polaris measures chain length in number of pitches.

**CI:** Cubic inches.

**Clutch Buttons:** Plastic bushings which transmit rotation of the clutch to the movable sheave in the drive and driven clutch.

**Clutch Offset:** Drive and driven clutches are offset so that drive belt will stay nearly straight as it moves along the clutch face.

**Clutch Weights:** Three levers in the drive clutch which relative to their weight, profile and engine RPM cause the drive clutch to operate.

**Condenser/Capacitor:** A storage reservoir for DC voltage.

**Crankshaft Run-Out:** Run-out or "bend" of crankshaft measured with a dial indicator while crankshaft is supported between centers on V blocks or resting in crankcase. Measure at various points especially at PTO.

**DCV:** Direct current voltage.

**Dial Bore Gauge:** A cylinder measuring instrument which uses a dial indicator. Good for showing taper and out-of-round in the cylinder bore.

**Electrical Open:** Open circuit. An electrical circuit which isn't complete.

**Electrical Short:** Short circuit. An electrical circuit which is completed before the current reaches the intended load. (i.e. a bare wire touching the chassis).

**End Seals:** Rubber seals at each end of the crankshaft.

**Engagement RPM:** Engine RPM at which the drive clutch engages to make contact with the drive belt.

**ft.:** Foot/feet.

**Foot Pound:** Ft. lb. A force of one pound at the end of a lever one foot in length, applied in a rotational direction.

**g:** Gram. Unit of weight in the metric system.

**gal.:** Gallon.

**HP:** Horsepower.

**ID:** Inside diameter.

**in.:** Inch/inches.

**Inch Pound:** In. lb. 12 in. lbs. = 1 ft. lb.

**kg/cm<sup>2</sup>:** Kilograms per square centimeter.

**kg-m:** Kilogram meters.

**Kilogram/meter:** A force of one kilogram at the end of a lever one meter in length, applied in a rotational direction.

**l or ltr:** Liter.

**lbs/in<sup>2</sup>:** Pounds per square inch.

**Left Side:** Always referred to based on normal operating position of the driver.

## GLOSSARY OF TERMS

**m:** Meter/meters.

**Mag:** Magneto.

**Magnetic Induction:** As a conductor (coil) is moved through a magnetic field, a voltage will be generated in the windings. Mechanical energy is converted to electrical energy in the stator.

**mi.:** Mile/miles.

**mm:** Millimeter. Unit of length in the metric system. 1mm = approximately .040".

**Nm:** Newton meters.

**OD:** Outside diameter.

**Ohm:** The unit of electrical resistance opposing current flow.

**oz.:** Ounce/ounces.

**Piston Clearance:** Total distance between piston and cylinder wall.

**psi.:** Pounds per square inch.

**PTO:** Power take off.

**PVT:** Polaris Variable Transmission (Drive Clutch System)

**qt.:** Quart/quarts.

**RPM:** Revolutions per minute.

**Regulator:** Voltage regulator. Regulates battery charging system output at approx. 14.5 DCV as engine RPM increases.

**Reservoir Tank:** The fill tank in the liquid cooling system.

**Resistance:** In the mechanical sense, friction or load. In the electrical sense, ohms. Both result in energy conversion to heat.

**Right Side:** Always referred to based on normal operating position of the driver.

**RPM:** Revolutions per minute.

**Secondary Clutch:** Driven clutch on chaincase or jackshaft.

**Seized Piston:** Galling of the sides of a piston. Usually there is a transfer of aluminum from the piston onto the cylinder wall. Possible causes: 1) improper lubrication; 2) excessive temperatures; 3) insufficient piston clearance; 4) stuck piston rings.

**Stator Plate:** The plate mounted under the flywheel supporting the battery charging coils.

**TDC:** Top dead center. Piston's most outward travel from crankshaft.

**Volt:** The unit of measure for electrical pressure of electromotive force. Measured by a voltmeter in parallel with the circuit.

**Watt:** Unit of electrical power. Watts = amperes x volts.

**WOT:** Wide open throttle.

**INSPECTION SCHEDULE**

Service Item	Initial Service (After two weeks)	Monthly	Every 6 Months	Yearly
Air Cleaner		C		
Fuel Filter			I	
Fuel/Oil Lines		I		
Battery		I		I
Brake Shoes			I	
Spark Plug			I	
Chain Lubrication		I		
Steering Lubrication		I		
Carburetor			C	
Throttle Control		I		
Tire Pressure		I		
Fasteners		T		
Gear Oil	R			R

R = Replace    C = Clean    T = Tighten    I = Inspect

**NOTE:** Inspection schedules are for reference only. If the vehicle is used often, more frequent inspections will be required.

## VEHICLE INSPECTION

### Front Brake

1. Each front brake has a cable connected to the right hand brake lever.

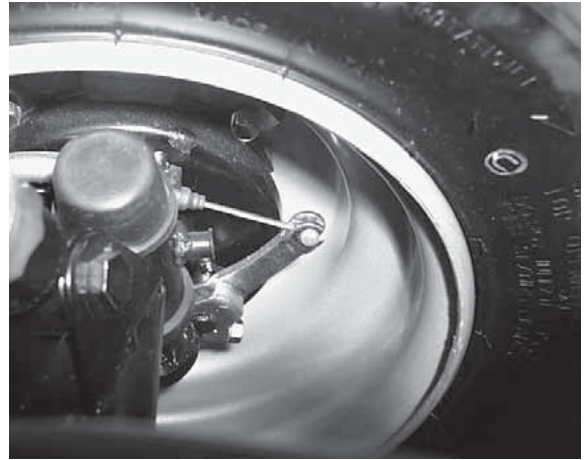

2. Loosen the adjuster nuts at the right hand brake lever. Turn the cable adjuster until the proper brake setting is achieved. Tighten nuts.

#### Front Brake Lever Free Play:

.40-.80" (10-20 mm)

#### Front Brake Lever Travel:

50 cc = 1 1/8" (28 mm)  
90 cc = 1 3/4" (45 mm)



### Rear Brake

3. The rear brake is operated using the left hand brake lever. To adjust the rear brake setting, turn the rear brake adjuster nut until brake is set to specification.

#### Rear Brake Lever Free Play:

.40-.80" (10-20 mm)

#### Rear Brake Lever Travel:

50 cc = 1 1/8" (28 mm)  
90 cc = 2 1/2" (65 mm)



### VEHICLE INSPECTION

#### Chain Adjustment

1. Remove the rear cover and loosen the four bearing housing bolts.

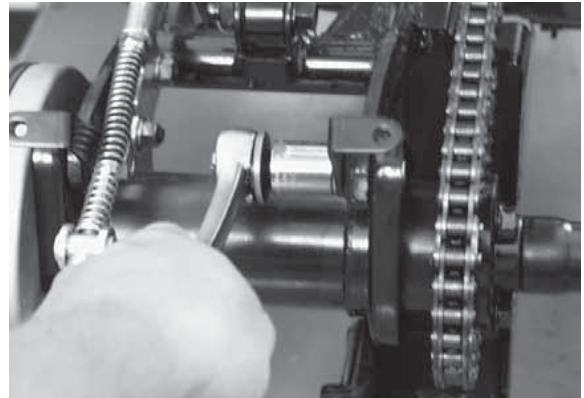

2. Loosen the chain adjuster lock nut. Turn the chain adjuster clockwise until chain is set to specification. Tighten the chain adjuster lock nut to specification.

**Chain Tension Specification:**

**3/8-3/4" (10-20 mm) Deflection**

**Chain Adjuster Lock Nut Torque:**

**84 in.lbs (9.4 Nm)**

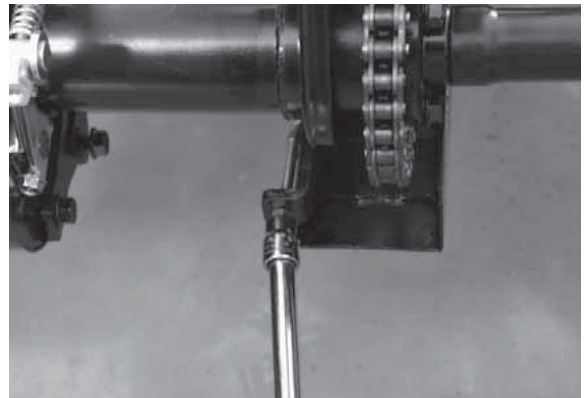

3. Tighten the four bearing housing bolts to specification. Re-install rear cover.

**Bearing Housing Bolt Torque:**

**43 ft.lbs (60 Nm)**

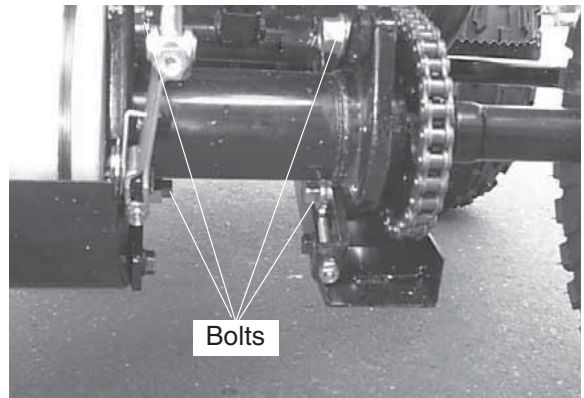

#### Lubrication

4. Lubricate grease fittings on spindles monthly with Polaris All Season Grease, or more frequently if used often.

**Polaris Premium All Season Grease  
14 oz. PN 2871423**

**Grease Gun Kit PN 2871312**





## VEHICLE INSPECTION

### Front Shocks and Springs

1. Inspect the front shocks and springs to ensure proper function. If the shock is leaking oil, replace. The spring preload can be adjusted on the Sportsman 90 by turning the adjuster nut. Inspect the A-arm and weldments for any sign damage.

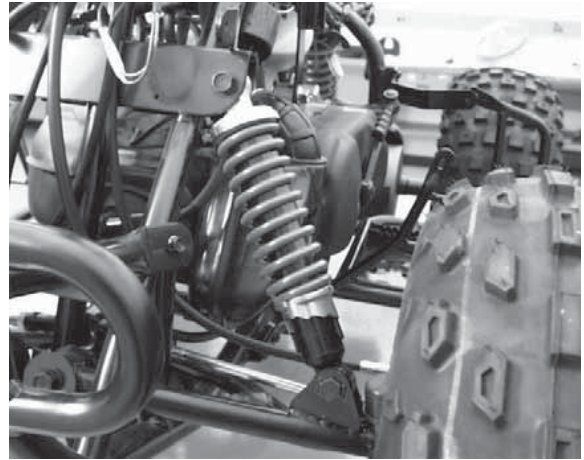

### Rear Shock and Spring

2. Inspect the rear shock and spring to ensure proper function. If the shock is leaking oil, replace. Inspect the swing arm and weldments for any sign of damage.

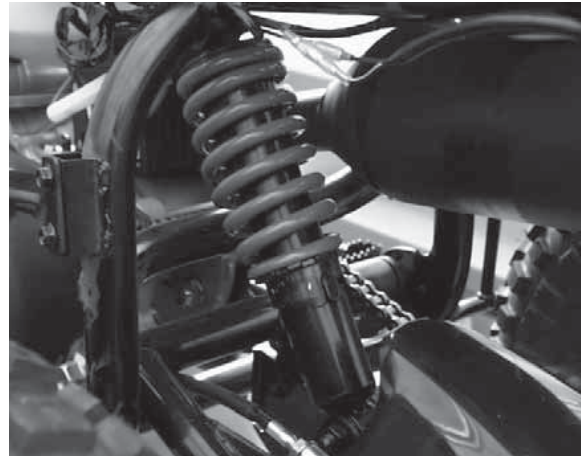

### Wheel Nuts

3. Inspect the front and rear wheel nuts for tightness. Re-torque wheel nuts monthly to specification.

**Wheel Nut Torque:**

**22-29 ft.lbs (30-40 Nm)**



### TRANSMISSION LUBRICATION

The transmission lubricant level should be checked and changed in accordance with the maintenance schedule.

Be sure vehicle is level before proceeding.

Check vent hose to be sure it is routed properly and unobstructed.

Follow instructions on following pages to check / change transmission lubricant.

#### TRANSMISSION SPECIFICATIONS

*Specified Lubricant:*

Polaris Premium Synthetic Gearcase Lubricant  
PN 2871477 (Gallon) PN 2871478 (12 oz..)

*Capacity:* . . . . . 10 fl.oz. / 300 ml

*Operating Range:* 1/2" (12.7 mm) below  
tip of dipstick.

*Drain Plug Torque:*

14 ft. lbs. (19.4 Nm)

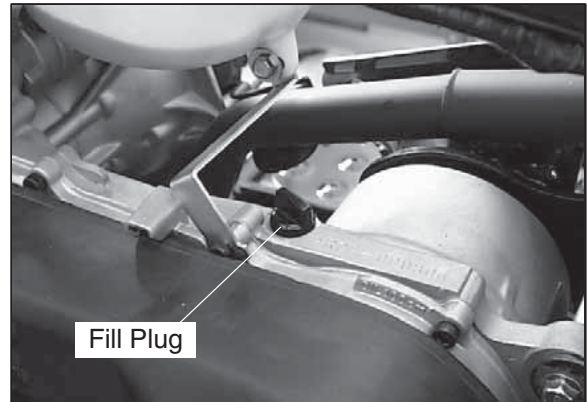

To check the level:

1. Remove fill plug and wipe clean.
2. Reinstall fill plug completely, remove and check the level. Add the proper lubricant as required to bring level into operating range. Operating range is 1/2" (12.7 mm) below the tip of the dipstick.

To change lubricant:

1. Place a drain pan beneath the transmission oil drain plug area.
2. Remove the drain plug and wipe the magnetic end clean to remove accumulated metallic filings.
3. After the oil has drained completely, install a new sealing washer and install the drain plug. Torque to 14 ft. lbs. (19.3 Nm).
4. Add the proper lubricant through the fill plug hole. Do not overfill.
5. Check for leaks.

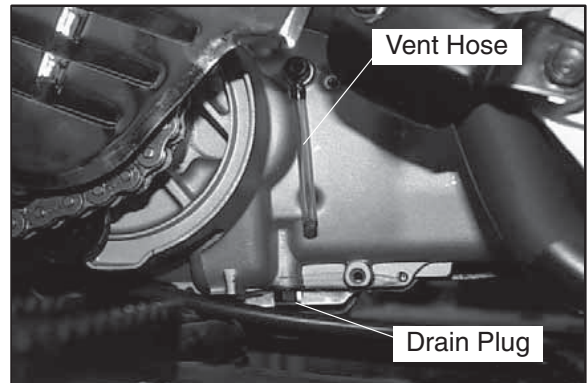

## THROTTLE OPERATION

Check for smooth throttle opening and closing in all handlebar positions. Throttle lever operation should be smooth and lever must return freely without binding.

1. Start the engine and let it idle.
2. Turn handlebars from full right to full left. If idle speed increases at any point in the turning range, inspect throttle cable routing and condition.
3. Replace the throttle cable if worn, kinked, or damaged.

## AIR SCREW ADJUSTMENT

1. Turn carburetor air screw in (clockwise) until lightly seated. Back screw out the specified number of turns.

**Air Screw Adjustment:**

**1.5 Turns Out from Lightly Seated**

2. Warm up the engine to operating temperature (about 10 minutes).
3. Set idle speed to 600 RPM.

**NOTE:** Adjusting the air screw may affect idle speed. Always check throttle cable freeplay after adjusting idle speed and adjust if necessary.

4. Turn the screw in (to richen) or out (to lean) the mixture. Adjust air screw for best throttle response and smooth idle.
5. Re-adjust idle speed if necessary.

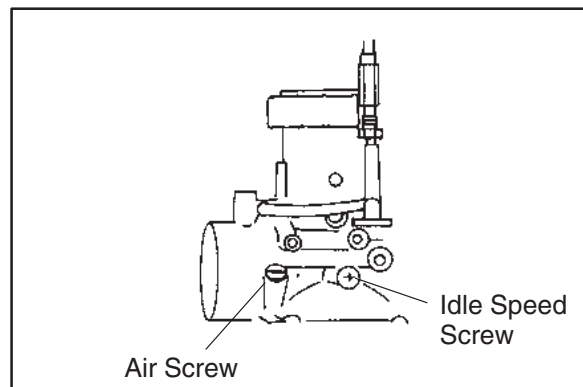

### IDLE SPEED ADJUSTMENT

1. Start engine and warm it up thoroughly.
2. Adjust idle speed by turning the idle adjustment screw in (clockwise) to increase or out (counterclockwise) to decrease RPM. (Refer to Ill. at right).

**NOTE:** Adjusting the idle speed affects throttle cable freeplay and electronic throttle control (ETC) adjustment. Always check throttle cable freeplay after adjusting idle speed and adjust if necessary.

**Idle Speed:**

**600 ± 200 RPM**

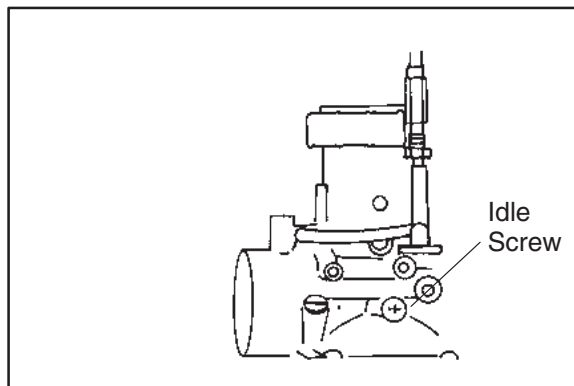

### THROTTLE CABLE / ELECTRONIC THROTTLE CONTROL (ETC SWITCH) ADJUSTMENT

1. Slide boot off throttle cable adjuster and jam nut.
2. Set parking brake.
3. Start engine and set idle to specified RPM.

**NOTE:** Be sure the engine is at operating temperature. See Idle Speed Adjustment.

4. Loosen lock nut on in-line cable adjuster (Ill. 1).
5. Turn cable adjuster out until engine RPM begins to increase.
6. Turn cable adjuster back in until throttle lever has 1/16" (.16 cm) of travel before engine RPM increases.

**NOTE:** Be sure ETC switch plunger is held inward by throttle cable tension (see ill. 2).

7. Tighten lock nut securely and slide boot completely in place to ensure a water-tight seal.

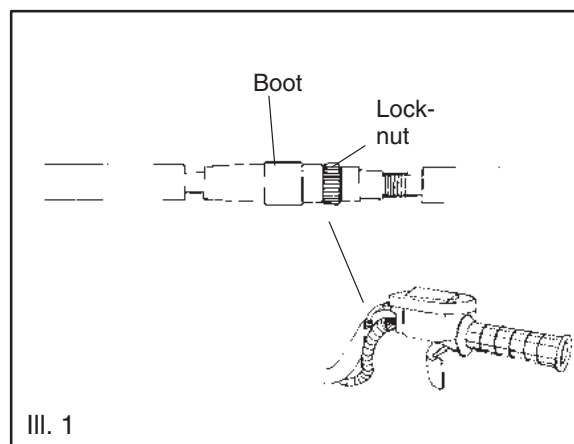

Ill. 1

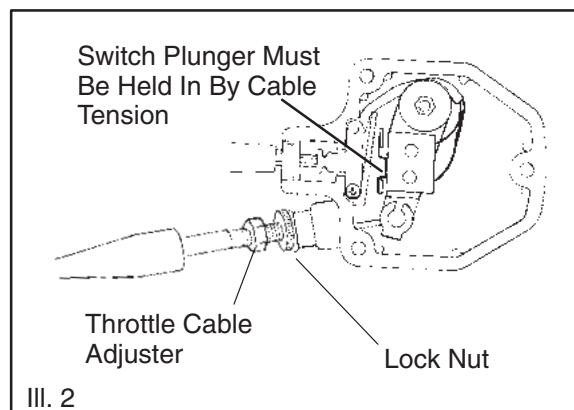

Ill. 2

## THROTTLE CABLE / ELECTRONIC THROTTLE CONTROL (ETC SWITCH) ADJUSTMENT, CONT.

**NOTE:** Whenever throttle cable adjustments are made, always check oil pump adjustment and re-adjust if necessary.

- Turn handlebars from left to right through the entire turning range. If idle speed increases, check for proper cable routing. If cable is routed properly and in good condition, repeat adjustment procedure.

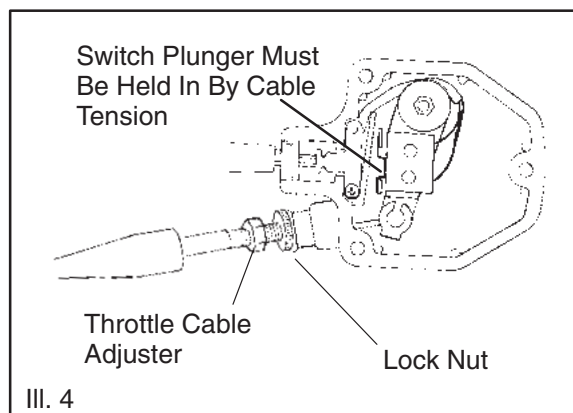
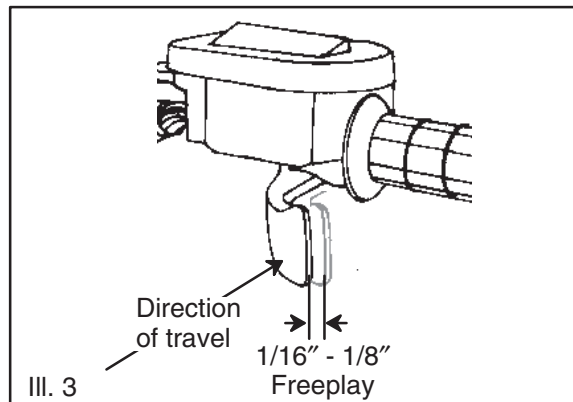

### OIL PUMP ADJUSTMENT PROCEDURE

1. Before adjusting the oil pump, check engine idle RPM and set to specification. Adjust if necessary.
2. Check and adjust throttle lever free play (ETC switch).
3. Apply parking brake.
4. Remove fan shroud.
5. Start the engine and let it idle.

**CAUTION:** Keep away from moving fan.

6. Place very slight pressure on the throttle lever until all freeplay is removed from throttle cable to carburetor (to the point where the carb slide is just starting to rise and engine RPM begins to increase).
7. Expose oil pump adjuster. Loosen lock nut and turn adjuster in or out until all freeplay is removed from oil pump cable (the point where the oil pump arm is just starting to move off of its stop).

**NOTE:** The pump stop keeps the pump arm from rotating any farther down than the idle position so no visual alignment of marks is necessary.

8. Replace oil pump adjuster covers.

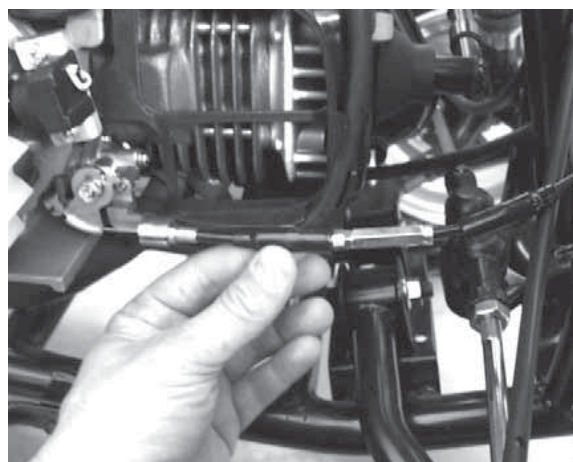
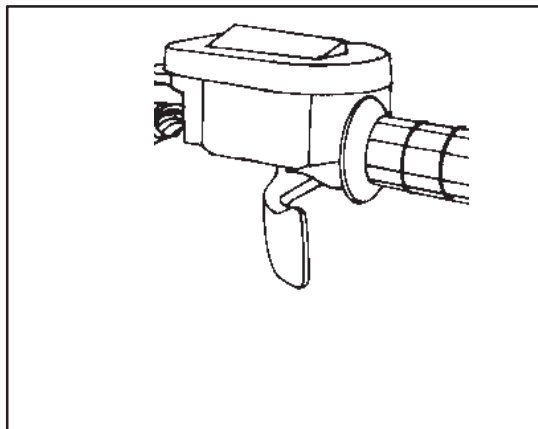

### OIL PUMP BLEEDING PROCEDURE

1. Fill the oil reservoir with Polaris injector oil.
2. Loosen the pump bleed screw one full turn. Allow oil to flow from the bleed screw for five to ten seconds. Tighten bleed screw. **CAUTION:** Never run the engine with the bleed screw loose. Loss of oil will cause serious engine damage.
3. Start the engine and turn the oil pump lever or reel to its full up (open) position. Allow engine to idle with the lever in this position for ten to twenty seconds to make sure all air is out of the system.

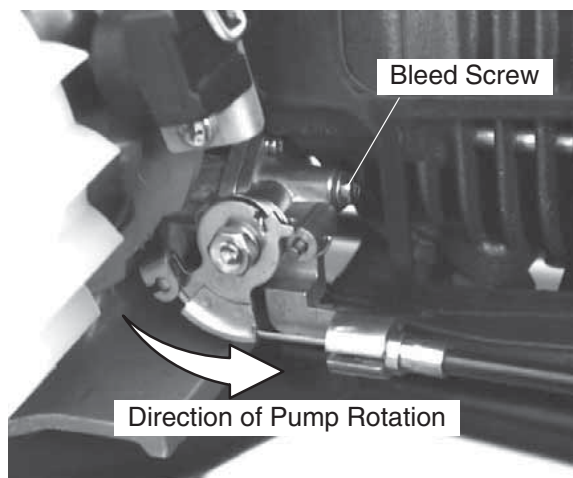

## OIL PUMP TROUBLESHOOTING PROCEDURE

To verify oil delivery to engine, proceed as follows:

1. Premix fuel in tank at a 40:1 fuel/oil ratio.
2. With the oil reservoir full and the pump bled, remove the oil delivery line from the intake manifold.
3. Test the oil delivery check valve with a low pressure pump and gauge.
4. Start engine and lift oil pump lever to full open position.
5. Oil should pulse from the delivery line every few seconds. If it does not, suspect one of the following:
  - A. Oil line plugged
  - B. Oil tank vent line restricted
  - C. Oil line leaking or blocked
  - D. Faulty oil pump or drive mechanism
  - E. Air in oil Lines
  - F. Insufficient/Improper oil in oil tank

### FUEL SYSTEM

#### ⚠ WARNING

*Gasoline is extremely flammable and explosive under certain conditions.*

- ⚠ Always stop the engine and refuel outdoors or in a well ventilated area.
- ⚠ Do not smoke or allow open flames or sparks in or near the area where refueling is performed or where gasoline is stored.
- ⚠ Do not overfill the tank. Do not fill the tank neck.
- ⚠ If you get gasoline in your eyes or if you swallow gasoline, see your doctor immediately.
- ⚠ If you spill gasoline on your skin or clothing, immediately wash it off with soap and water and change clothing.
- ⚠ Never start the engine or let it run in an enclosed area. Gasoline powered engine exhaust fumes are poisonous and can cause loss of consciousness and death in a short time.
- ⚠ Never drain the float bowl when the engine is hot. Severe burns may result.

### FUEL LINES

1. Check fuel lines for signs of wear, deterioration, damage or leakage. Replace if necessary.
2. Be sure fuel lines are routed properly and secured with cable ties. **CAUTION:** Make sure lines are not kinked or pinched.
3. Replace all fuel lines every two years.

### VENT LINES

1. Check fuel tank, oil tank, carburetor, battery and transmission vent lines for signs of wear, deterioration, damage or leakage. Replace every two years.
2. Be sure vent lines are routed properly and secured with cable ties. **CAUTION:** Make sure lines are not kinked or pinched.

### FUEL FILTER

The fuel filter should be replaced in accordance with the Periodic Maintenance Chart or whenever sediment is visible in the filter.

1. Shut off fuel supply at fuel valve.
2. Remove line clamps at both ends of the filter.
3. Remove fuel lines from filter.
4. Install new filter and clamps onto fuel lines.
5. Turn fuel valve ON.
6. Start engine and inspect for leaks.





## CARBURETOR DRAINING

The carburetor float bowl should be drained periodically to remove moisture or sediment from the bowl, or before extended periods of storage.

**NOTE:** A drain plug is located on the side of the float bowl.

1. Turn fuel valve to the off position.
2. Place a clean container beneath the bowl drain spigot or bowl drain hose.
3. Loosen drain screw and allow fuel in the float bowl and fuel line to drain completely.
4. Inspect the drained fuel for water or sediment.
5. Tighten drain screw.
6. Turn fuel valve to "on".
7. Check for fuel leaks.
8. Start engine and re-check for leaks.

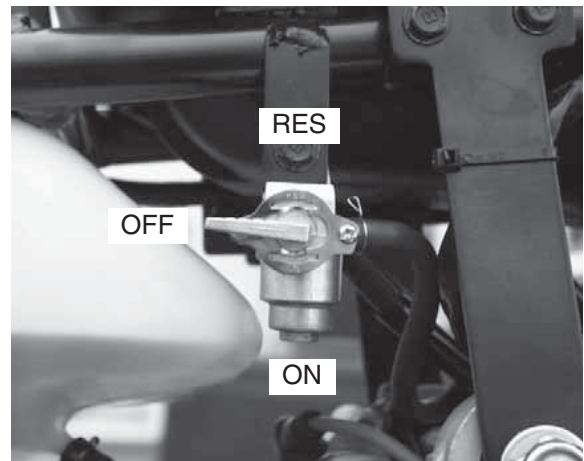
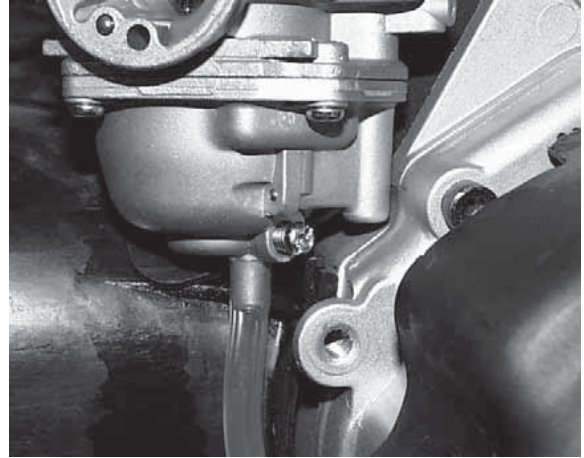

### COMPRESSION TEST

1. Remove spark plug and install compression tester.
2. Connect high tension lead to a good ground on engine.
3. Open throttle and crank engine until maximum reading is obtained (approximately 3-5 revolutions).

#### **Cylinder Compression**

**Service Limit      115 PSI**

### AIR FILTER SERVICE

1. Remove three (3) screws on the airbox. Slide carburetor boot clamp off of carburetor.
2. Remove the airbox cover to expose the filter element.
3. Carefully wash the element in soapy water and dry it. Replace filter if necessary.
4. Lightly grease the sealing surfaces of the air filter cover. Install cover.
5. Install three (3) screws and boot clamp.

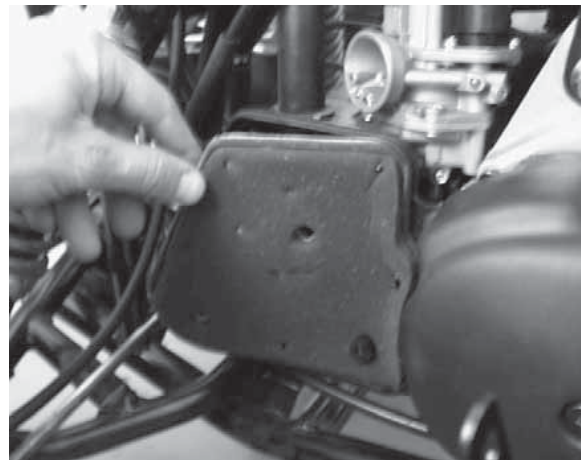
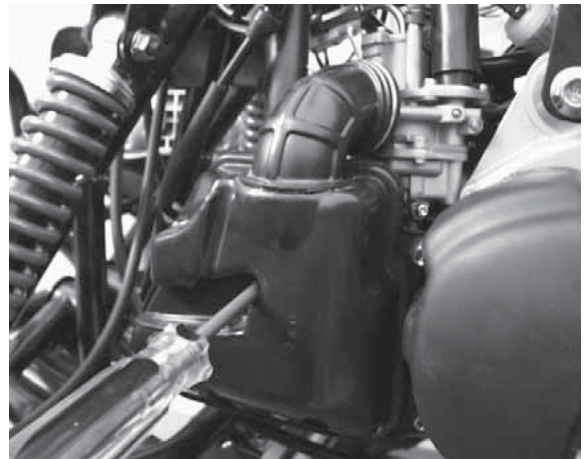

## WHEELS

Inspect all wheels for runout or damage. Check wheel bolts and ensure they are tight. Do not over tighten the wheel bolts.

## WHEEL, HUB, AND SPINDLE TORQUE TABLE

Item	Specification
Front Wheel Bolts	22-29 Ft. Lbs. (30-40 Nm)
Rear Wheel Bolts	22-29 Ft. Lbs. (30-40 Nm)
Front Spindle Nut	42-45 Ft. Lbs. (58-62 Nm)
Rear Hub Retaining Nut	78-81 Ft. Lbs. (108-112 Nm)

## WHEEL REMOVAL FRONT OR REAR

1. Stop the engine and lock the parking brake.
2. Loosen the wheel bolts slightly.
3. Elevate the side of the vehicle by placing a suitable stand under the footrest frame.
4. Remove the wheel nuts and remove the wheel.

## WHEEL INSTALLATION

1. With the transmission in gear and the parking brake locked, place the wheel in the correct position on the wheel hub. Be sure the valve stem is toward the outside and rotation arrows on the tire point toward forward rotation.
2. Attach the wheel nuts and finger tighten them.
3. Lower the vehicle to the ground.
4. Securely tighten the wheel nuts to the proper torque listed in the table above.

**CAUTION:**

If wheels are improperly installed it could affect vehicle handling and tire wear.

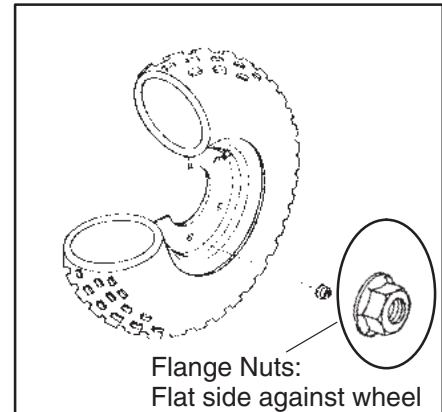

## GENERAL INFORMATION

### TIRE PRESSURE

Tire Pressure Inspection (PSI - Cold)	
Front	Rear
2	2

### TIRE INSPECTION

#### CAUTION:

Maintain proper tire pressure. Refer to the tire pressure warning decal applied to the vehicle.

Improper tire inflation may affect ATV maneuverability.

When replacing a tire always use original equipment size and type.

The use of non-standard size or type tires may affect ATV handling.

#### Tire Tread Depth

Always replace tires when tread depth is worn to 1/8" (3 mm) or less.

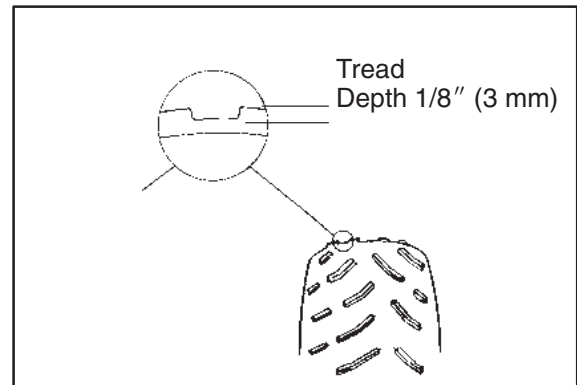

## ⚠ WARNING

Operating an ATV with worn tires will increase the possibility of the vehicle skidding easily with possible loss of control.

Worn tires can cause an accident.

Always replace tires when the tread depth measures 1/8" (.3 cm) or less.

### FRAME, NUTS, BOLTS, FASTENERS

Periodically inspect the torque of all fasteners in accordance with the maintenance schedule. Check that all cotter pins are in place. Refer to specific fastener torques listed in each chapter.

**TOE ALIGNMENT - METHOD 1: STRAIGHTEDGE OR STRING**

Be sure to keep handlebars centered. See note below.

**NOTE:** String should just touch side surface of rear tire on each side of machine.

Measure from string to rim at front and rear of rim.

Rear rim measurement should be 1/16" to 1/8" (.2 to .3 cm) more than front rim measurement.

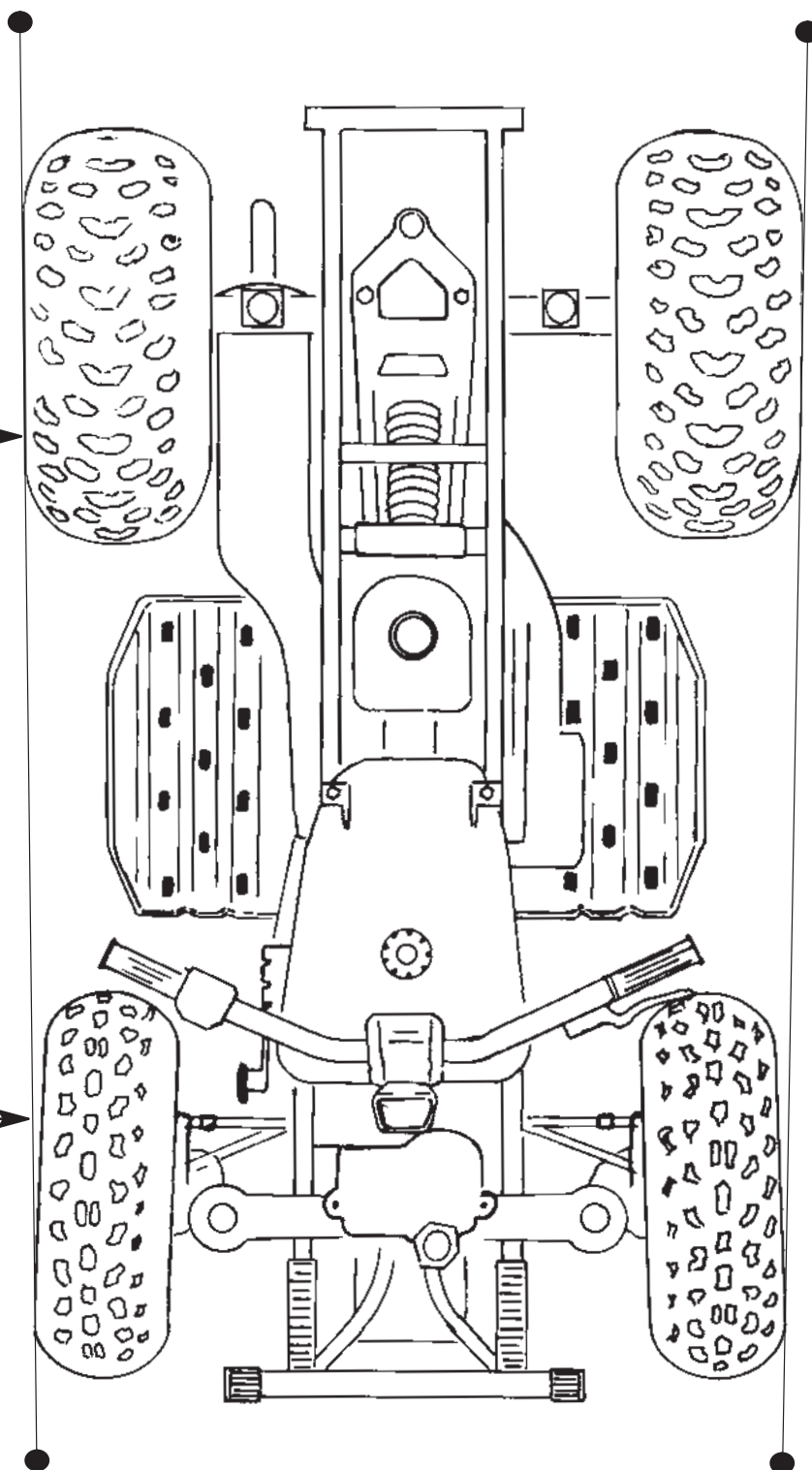

**NOTE:** The steering post arm (frog) can be used as an indicator of whether the handlebars are straight. The frog should always point straight back from the steering post.

### TOE ALIGNMENT - METHOD 2 CHALK

1. Place machine on a smooth level surface.
2. Set handlebars in a straight ahead position and secure handlebars in this position. **NOTE:** The steering frog can be used as an indicator of whether the handlebars are straight. The frog should always point straight back from the steering post.
3. Place a chalk mark on the face of the front tires approximately 10" (25.4 cm) from the floor as close to the hub/axle center line as possible. **NOTE:** It is important that both marks be equally positioned from the ground in order to get an accurate measurement.
4. Measure the distance between the marks and record the measurement. Call this measurement "A".
5. Rotate the tires 180° by moving vehicle forward or backward. Position chalk marks facing rearward, even with the hub/axle centerline.
6. Again measure the distance between the marks and record. Call this measurement "B". Subtract measurement "B" from measurement "A". The difference between measurements "A" and "B" is the vehicle toe alignment. The recommended vehicle toe tolerance is 1/8" to 1/4" (.3 to .6 cm) toe out. This means the measurement at the front of the tire (A) is 1/8" to 1/4" (.3 to .6 cm) wider than the measurement at the rear (B).

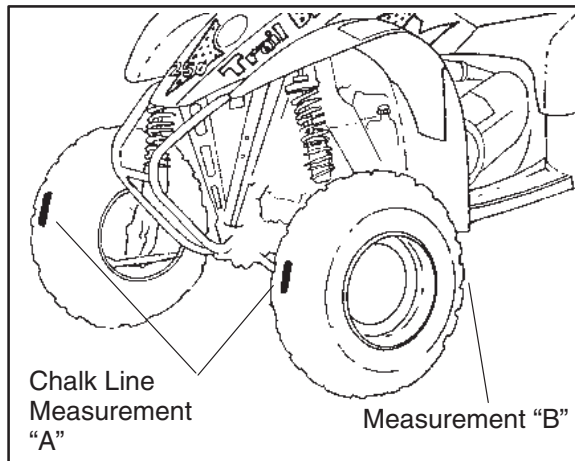

### TOE ALIGNMENT ADJUSTMENT

1. If toe alignment is incorrect, measure the distance between vehicle center and each wheel. This will tell you which tie rod needs adjusting. **NOTE:** Be sure handlebars are straight ahead before determining which tie rod(s) need adjustment.

**CAUTION:** During tie rod adjustment it is very important that the following precautions be taken when tightening tie rod end jam nuts. If the rod end is positioned incorrectly it will not pivot, and may break.

#### To adjust toe alignment:

Hold tie rod end to keep it from rotating.

Loosen jam nuts at both end of the tie rod.

Shorten or lengthen the tie rod until alignment is as required to achieve the proper toe setting as specified in Method 1 (1/16" to 1/8") or Method 2 (1/8" to 1/4").

When the tie rod end jam nuts are tightened, be sure to hold tie rod ends so they are parallel with the steering arm or the steering frog, respectively, to prevent rod end damage.

2. After alignment is complete, torque jam nuts to 33-40 ft. lbs. (45-55 Nm).

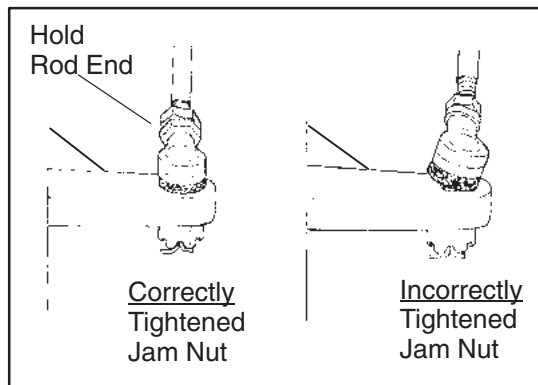

# ***CHAPTER 2***

## ***ENGINE***

Torque Specifications .....	2.1
Special Tools, Engine .....	2.1
Engine Installation Notes .....	2.2
Engine Disassembly .....	2.3-2.12
Engine Inspection .....	2.13-2.15
Cylinder Honing .....	2.16
Crankshaft Runout Inspection .....	2.17
Engine Assembly .....	2.18-2.16
Spark Plug Fouling .....	2.27
Engine Troubleshooting .....	2.28-2.29





## TORQUE SPECIFICATIONS

TORQUE SPECIFICATIONS	
Fastener	Torque
Carburetor Adaptor	20 in.lbs (2.25 Nm)
Crankcase	86 in.lbs (10 Nm)
Intake Manifold Bolts	108 in.lbs (12 Nm)
Cylinder Head Nuts	14 ft.lbs (19 Nm)
Drive Clutch Nut	29 ft.lbs (39 Nm)
Driven Clutch Nut Torque	25 ft.lbs (34 Nm)
Transmission Cover Bolts	84 in.lbs (9.5 Nm)
Flywheel	25 ft.lbs (34 Nm)
Oil Drain Bolt (Transmission)	14 ft.lbs (19 Nm)
Oil Pump Bolts	43 in.lbs (5 Nm)
Fan Housing	84 in.lbs (9.5 Nm)
Fan Bolts	84 in.lbs (9.5 Nm)
Stator Plate	84 in.lbs (9.5 Nm)
Starter Motor Bolts	84 in.lbs (9.5 Nm)
Spark Plug	11 ft.lbs (15 Nm)

## SPECIAL TOOLS

PART NUMBER	DESCRIPTION
0450697	Crankshaft Removal Tool (TE0210)
0450698	Flywheel Puller (TE040)
0450699	Oil Pump Drive Gear Removal Tool (TE041)
0450700	Crankcase Separating Tool (TE310)

### **ENGINE INSTALLATION NOTES**

#### **General Items**

1. Install previously removed components using new gaskets, seals, and fasteners where applicable.
2. Perform regular checks on fluid levels, controls, and all important areas on the vehicle as outlined in the daily pre-ride inspection checklist.

#### **Exhaust**

1. Replace exhaust gaskets. Seal connections with high temp silicone sealant.
2. Check to be sure all springs are in good condition.

#### **Engine Break In Period**

Engine Break-In Period is defined as the first 10 hours of engine operation, or 2 full tanks of fuel.

1. Use only Polaris Premium 2 cycle engine oil. Never substitute or mix oil brands. Serious engine damage can result.
2. Use fuel with a minimum octane of 87 (R+M)/2 method.

## ENGINE DISASSEMBLY

### Fan Cover and Cylinder Air Shroud

1. Remove the fasteners on fan cover.

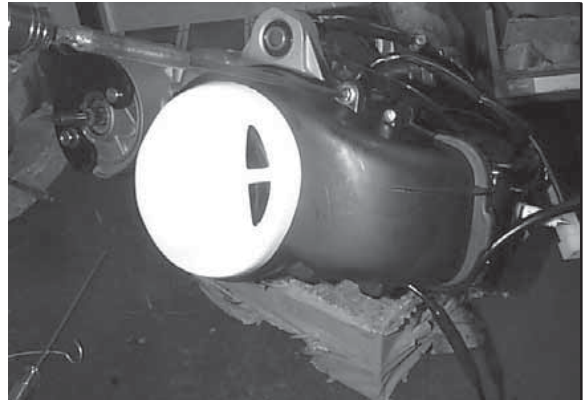

2. Remove cylinder air shroud and deflector.

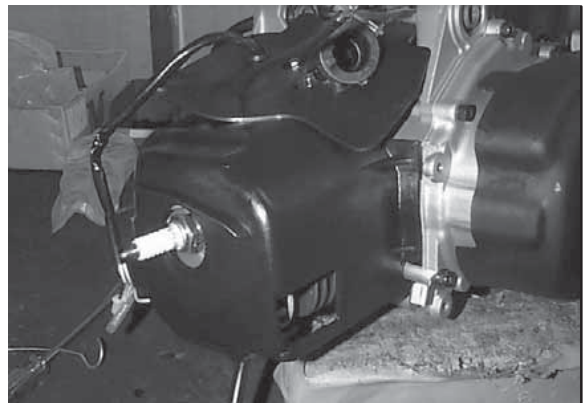

3. Loosen bolts securing fan and remove fan.

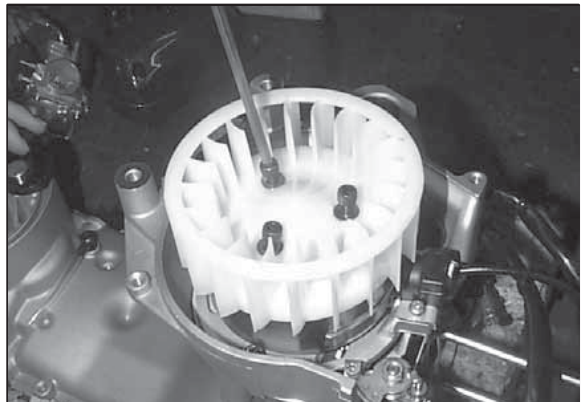

### Starter Motor

4. Remove starter motor.

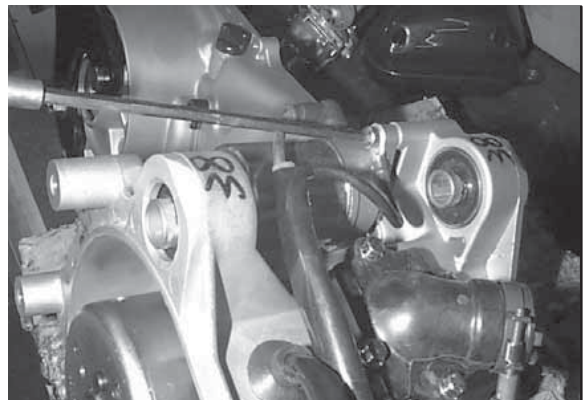

## ENGINE DISASSEMBLY, CONT.

### Inlet and Fuel System

- Slide air box-to-carburetor air clip out of the way and remove air duct.

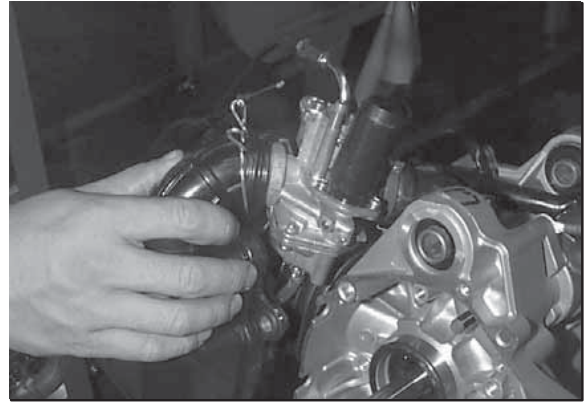

- Loosen carburetor adaptor screw and remove carburetor.

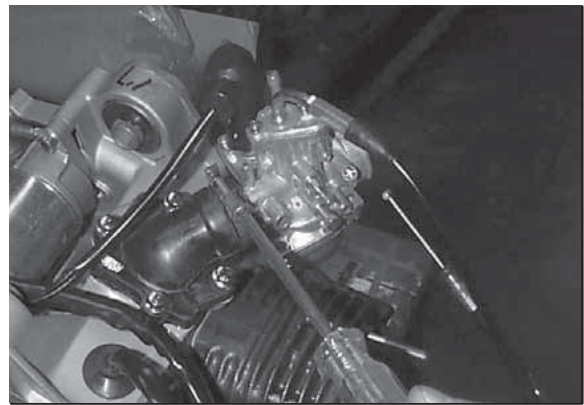

- Remove bolts securing the intake manifold. Remove intake manifold and reed valve.

**NOTE:** Remove any remaining gasket material from the reed valve housing and crankcase. Always replace the reed valve gasket when removing.

**NOTE:** Check the condition of the reed. If petals look damaged in any way, replace.

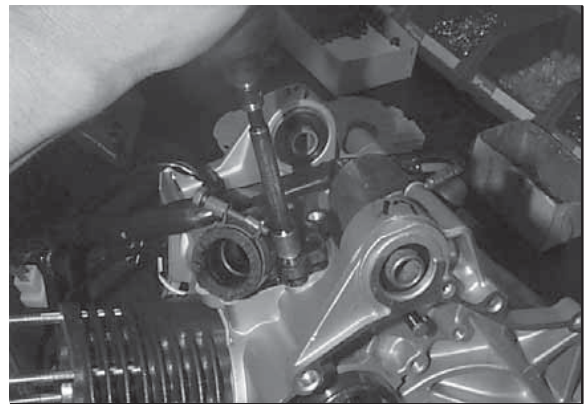

### Muffler, Cylinder and Cylinder Head

- Remove spark plug. Check the electrode for carbon and wear. Spark plug gap should be .024-.028" (.6-.7 mm).

**Spark Plug Gap:**

**.024-.028" (.6-.7 mm)**

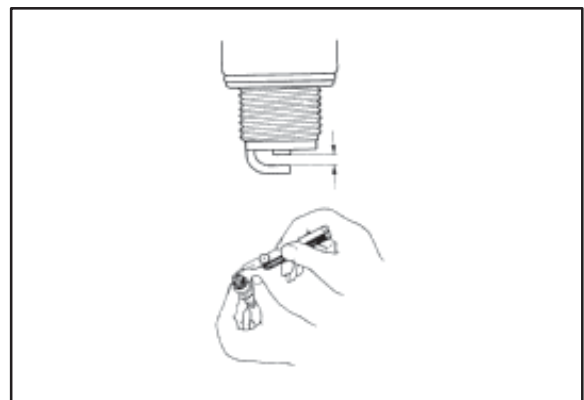

## ENGINE DISASSEMBLY, CONT.

9. Remove cylinder head nuts and remove cylinder head. Clean the head using parts washer solvent.

**NOTE:** Always replace head gasket with new.

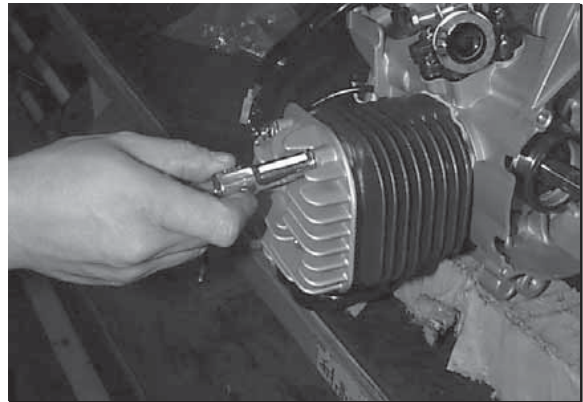

10. Remove cylinder. Clean the carbon from the cylinder walls and ports using parts washer solvent. Inspect the cylinder walls for signs of scoring.

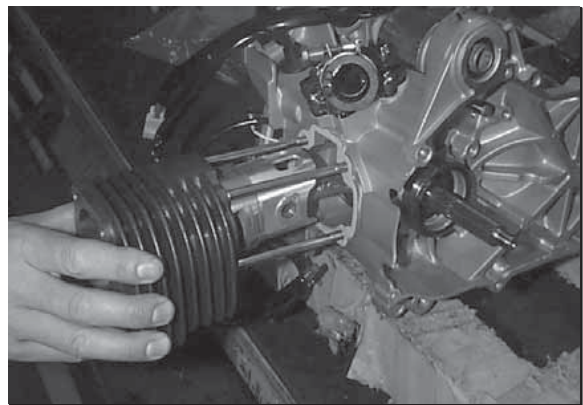

### **Piston Pin, Piston and Rings**

11. Remove piston pin circlips.



12. Remove piston pin and piston. Use care not to damage piston or pin. Inspect piston for scoring.



### ENGINE DISASSEMBLY, CONT.

13. Carefully remove piston rings so no damage is done to the ring lands. Discard rings and replace with new.

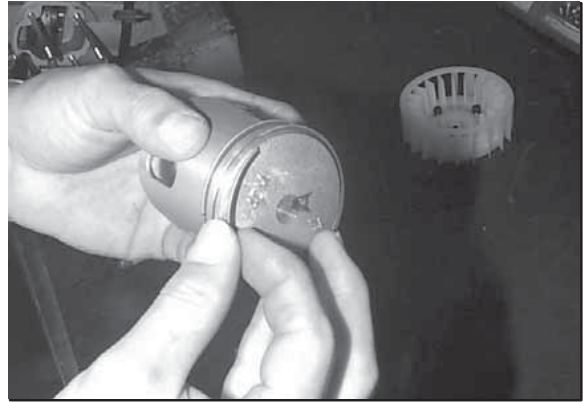

14. Remove small end bearing from connecting rod.

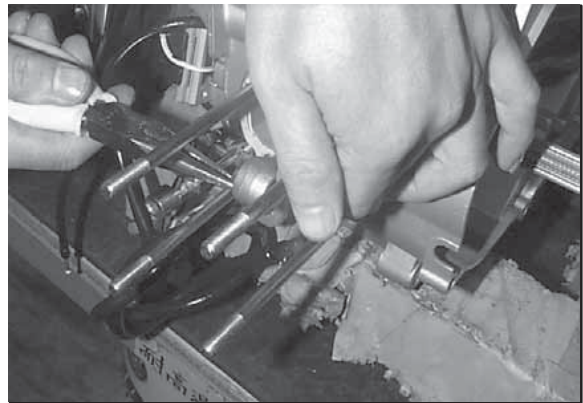

#### **Transmission System**

15. Loosen and remove all bolts, protectors, carburetor tube bracket, and cover (Scrambler 50). Remove gasket and discard.

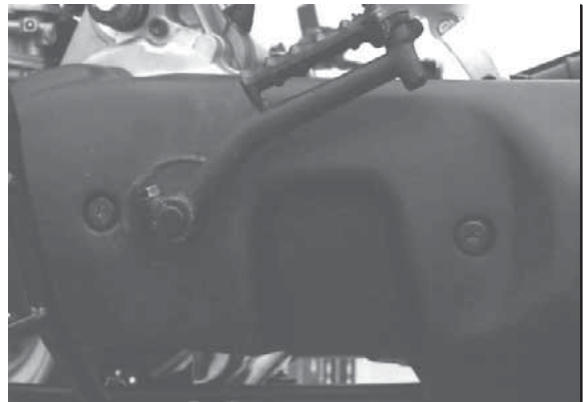

## ENGINE DISASSEMBLY, CONT.

16. Remove kick starter, bolts, grommets, protectors, filter, and remove carburetor tube bracket and crankcase cover (Sportsman 90 and Scrambler 90). Remove gasket and discard.

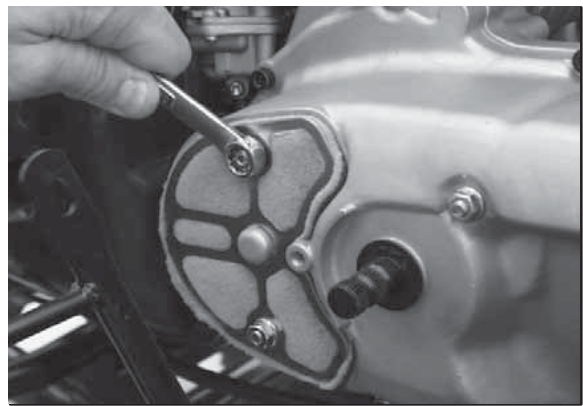
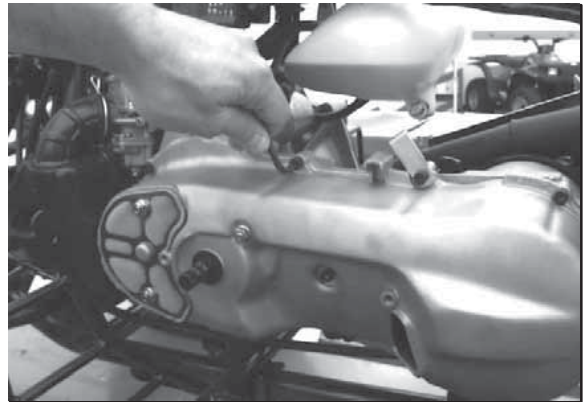

17. Remove drive clutch nut.

18. Remove one-way clutch washer.

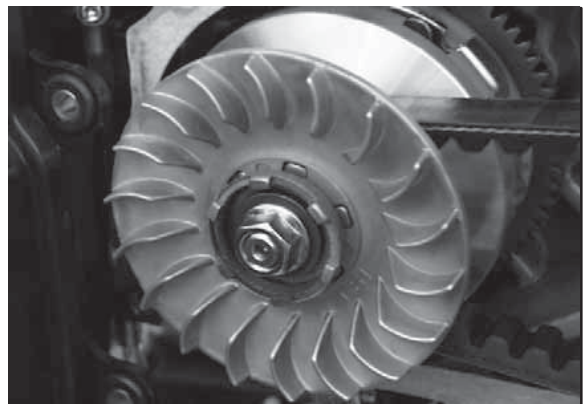

19. Remove the primary fixed sheave and claw washer.

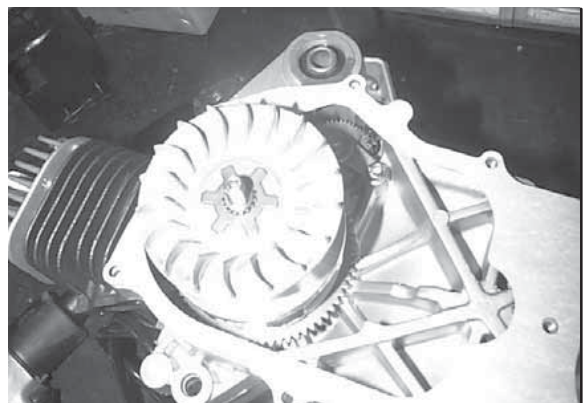

### ENGINE DISASSEMBLY, CONT.

20. Remove belt.

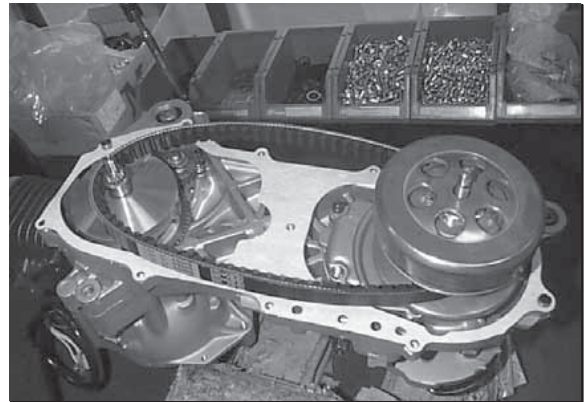

21. Remove primary clutch sheave.

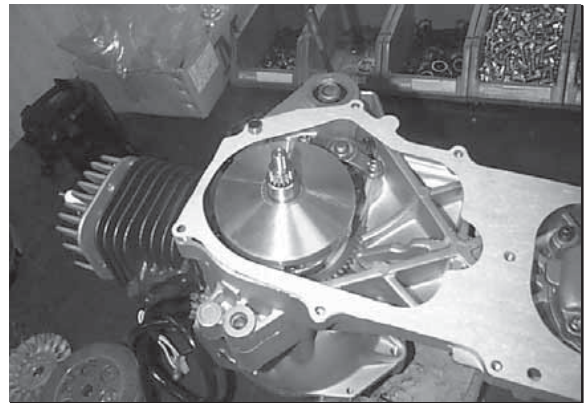

22. Remove the nut on driven clutch and remove clutch assembly.

**NOTE:** Be careful not to lose the oil ring upon removal.



#### Starter Clutch Set

23. Remove idle gear bolts.

24. Remove the plate, shaft pin, washers, and idle gear.

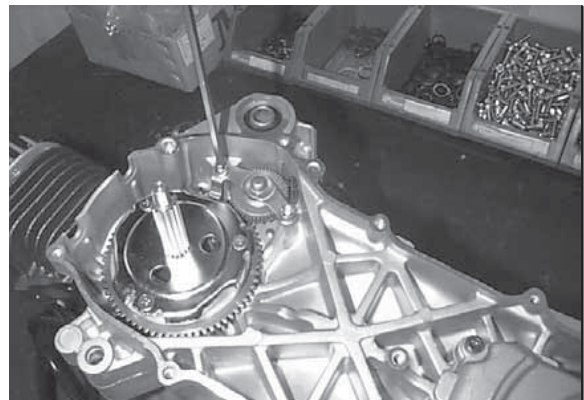



## ENGINE DISASSEMBLY, CONT.

25. Remove the starter clutch, starter gear, needle bearing, and washer.

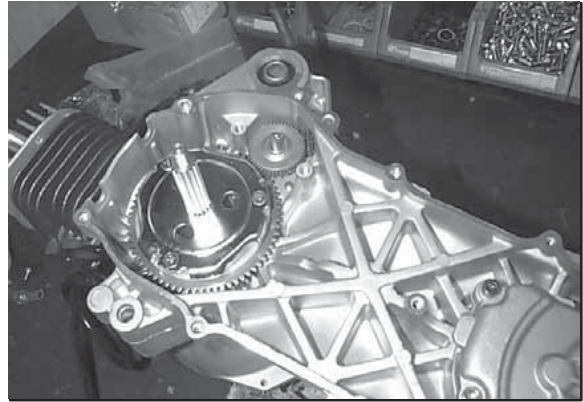

### Driven Shaft Assembly

26. Drain the oil from gear case.

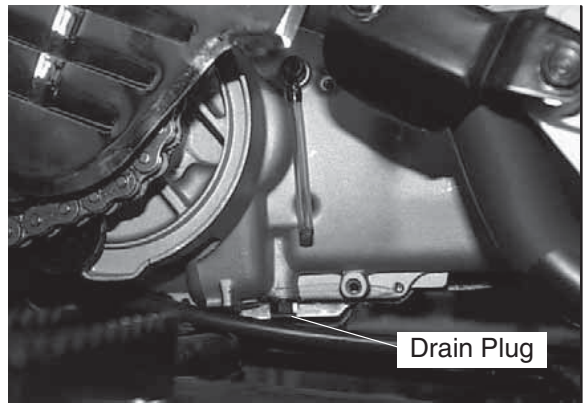

27. Remove transmission cover and gasket.

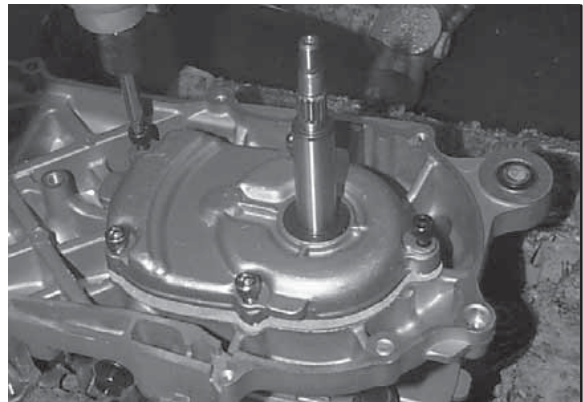

28. Remove the driven clutch shaft components and shaft assembly.

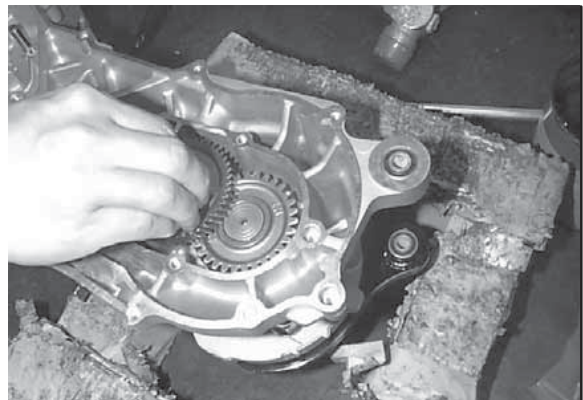

### ENGINE DISASSEMBLY, CONT.

#### Stator Assembly

29. Remove flywheel nut and washer.

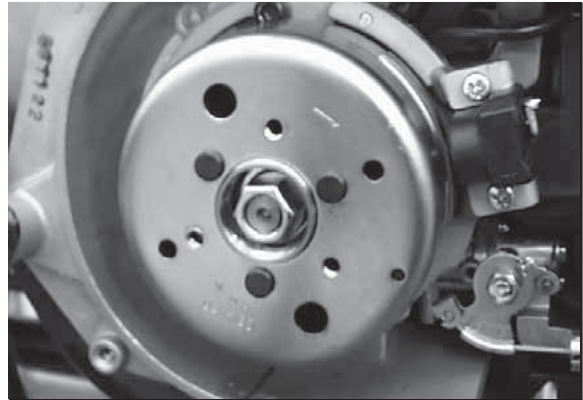

30. Remove the flywheel using flywheel puller.

**Flywheel Puller:**

**PN 0450698**

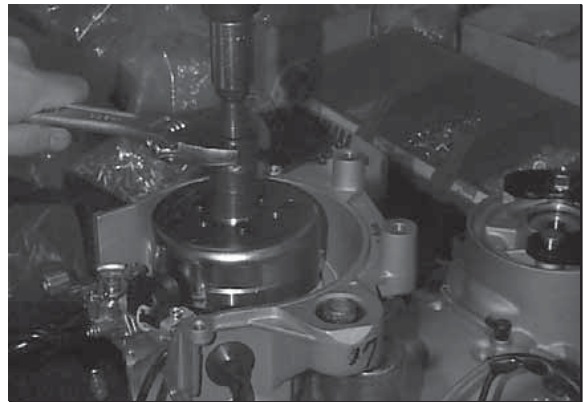

31. Scribe an alignment mark on the stator backing plate and the crankcase for proper alignment upon engine assembly. Remove stator assembly.

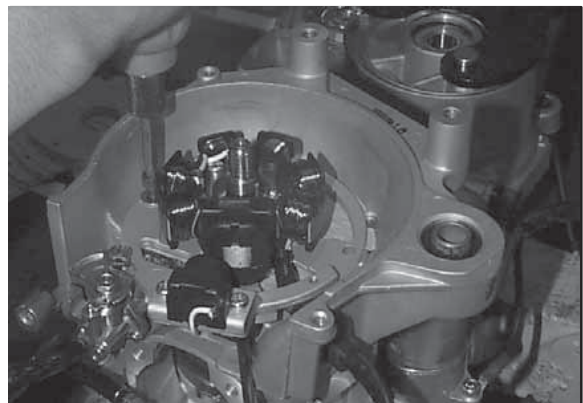

## ENGINE DISASSEMBLY, CONT.

### Oil Pump

32. Remove stator gasket, clean the area thoroughly. Loosen bolts and remove the oil pump.

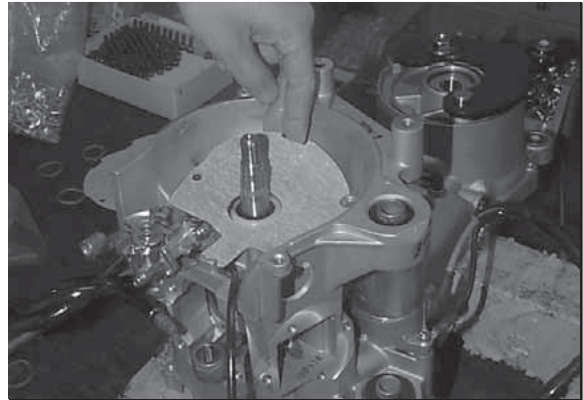

33. Remove external circlips and use a special tool to remove the oil pump drive gear.

**Oil Pump Drive Gear Removal Tool:**

**PN 0450699**

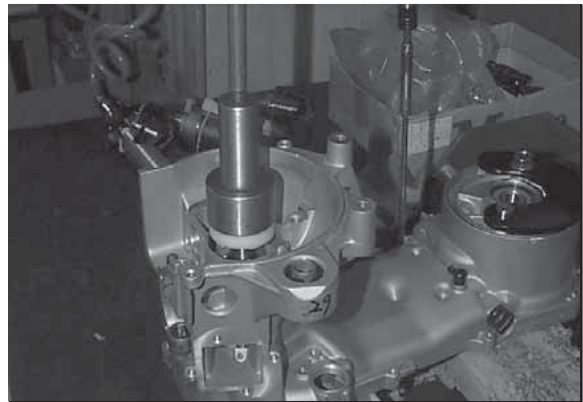

34. Loosen the bolts and remove the bracket.

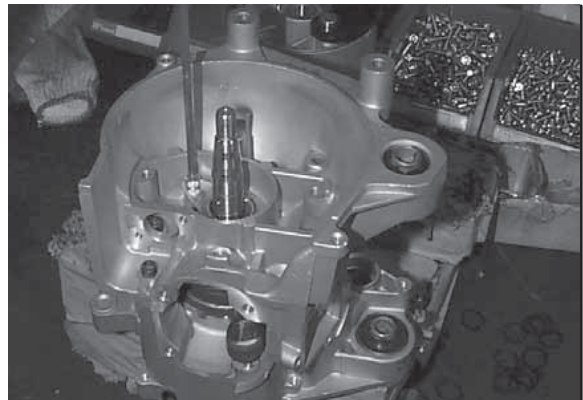

## ENGINE DISASSEMBLY, CONT.

### Crankcase

35. Remove all crankcase bolts. Use a special tool to disassemble the right and left crankcase halves.

**Crankcase Separating Tool:**

**PN 0450700**



36. Use a special tool to remove the crankshaft.

**Crankshaft Removal Tool:**

**PN 0450697**



37. Remove the external snap ring on the output shaft bearing and remove the oil seal.



## ENGINE INSPECTION PROCEDURES

### Cylinder Head Inspection

1. Inspect the surface of the cylinder head for warpage. Clean all gasket residue completely from sealing surface. Use a feeler gauge and straight edge. Measure the gap six(6) different ways as shown in illustration at left. Normal gap should be .002" (0.05 mm) or less. If gap is excessive, resurfacing head or replacement is needed.

**Cylinder Head Warp  
Service Limit:  
.002" (0.05 mm)**

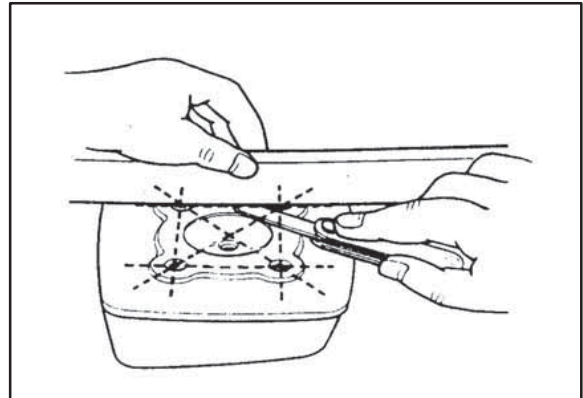

### Cylinder Inspection

2. Inspect the surface of the cylinder for warpage. Clean all gasket residue completely from sealing surface. Use a feeler gauge and straight edge. Measure the gap six(6) different ways as shown in illustration at left. Normal gap should be .002" (0.05 mm) or less. If gap is excessive, resurfacing cylinder or replacement is needed.

**Cylinder Warp  
Service Limit:  
.002" (0.05 mm)**

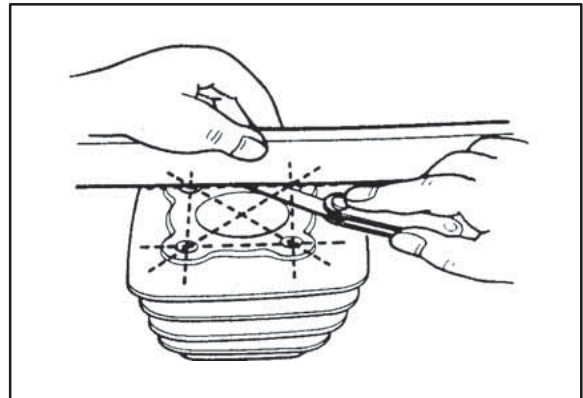

3. Inspect the cylinder walls for damage or scoring. The cylinder bore must be de-glazed whenever new piston rings are installed. If cylinder wear or damage is excessive, it will be necessary to oversize the cylinder using a new oversize piston and rings. See **Honing to Oversize** in this chapter. Inspect cylinder for out of round.

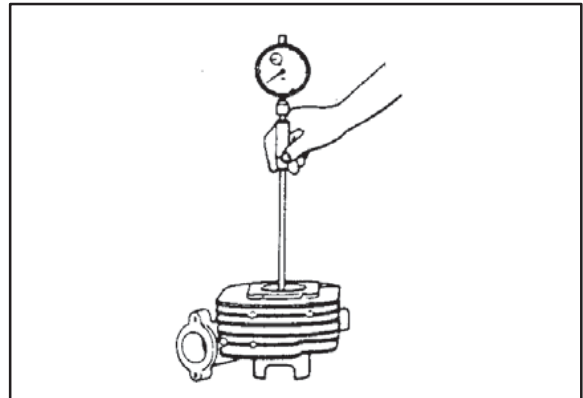

### Piston Inspection

4. Inspect the piston for scoring or cracks in piston crown or pin area. Excessive carbon buildup below the ring land is an indication of piston, ring, or cylinder wear. If damage is excessive, replace piston. Piston-to-cylinder clearance should not exceed .0047" (0.12 mm). Measure the piston 5/8" (15 mm) from bottom. Then measure inside diameter of cylinder. The difference between these measurements should not exceed .0047" (0.12 mm).

**Piston to Cylinder Clearance:  
.0047" (0.12 mm)**

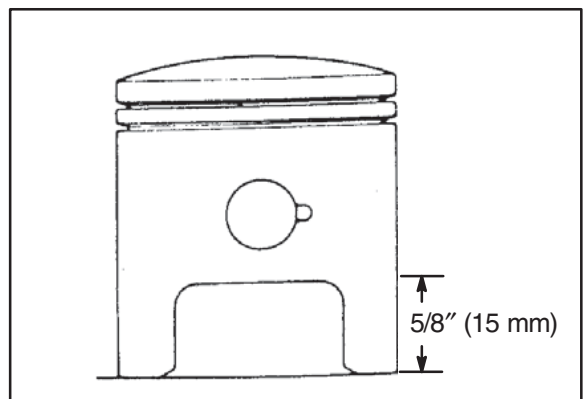

## ENGINE INSPECTION PROCEDURES, CONT.

### Piston Ring Installed Gap

1. Position piston ring 1/2" (1.3 cm) from the top of the cylinder using the piston to push it squarely into place. Measure installed gap with a feeler gauge at both the top and bottom of the cylinder. Replace rings if the installed end gap exceeds the service limit.

**Piston Ring Installed Gap**  
**Service Limit:**  
**.030" (0.75 mm)**

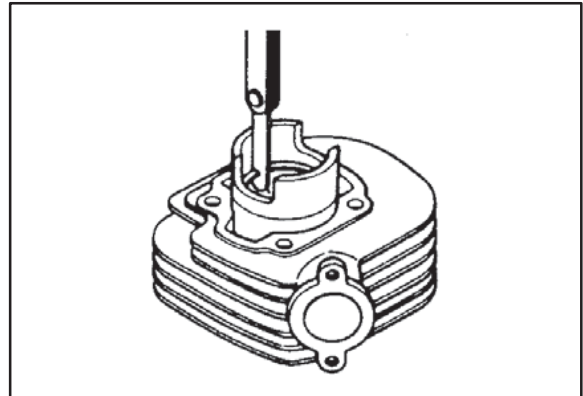

### Piston Pin Hole Inspection

2. Using a telescoping gauge or similar bore gauge, measure the inside diameter of the piston pin hole on both sides of the piston. Replace if diameter exceeds .395" (10.03 mm)

**Piston Pin Hole**  
**Service Limit:**  
**.395" (10.03 mm)**

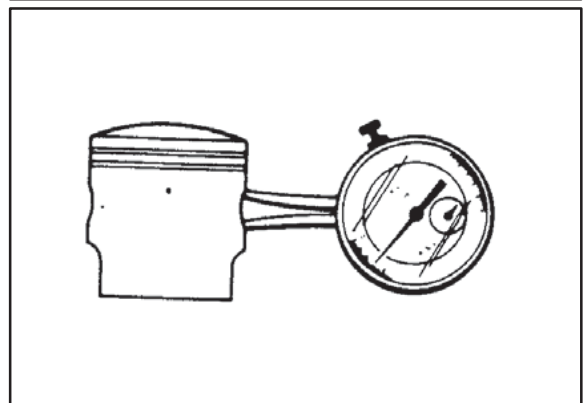

### Piston Pin Inspection

3. Inspect the surface of the piston pin for damage. Measure the diameter of the piston pin in three areas with a micrometer. The service limit for the piston pin is .393" (9.980 mm).

**Piston Pin**  
**Service Limit:**  
**.393" (9.980 mm)**

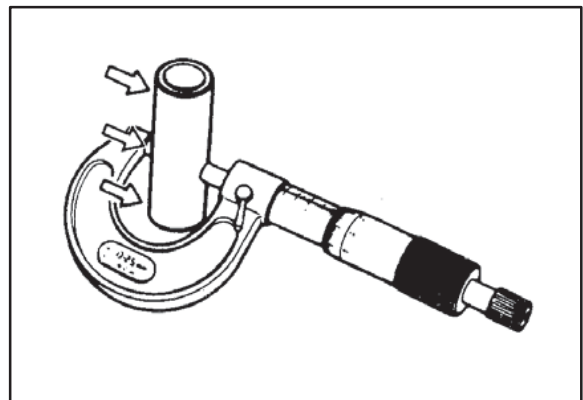

### Connecting Rod Inspection

4. Inspect the inner surface of the small end of the connecting rod for wear or damage. Oil and install needle bearing and pin in connecting rod. Rotate pin slowly and check for rough spots or any resistance to movement. Replace both pin and bearing if there is any resistance to rotation. Measure the inner diameter of the small end of the connecting rod. The service limit is .553" (14.04 mm.)

**Connecting Rod Small End**  
**Service Limit**  
**.553" (14.04 mm)**

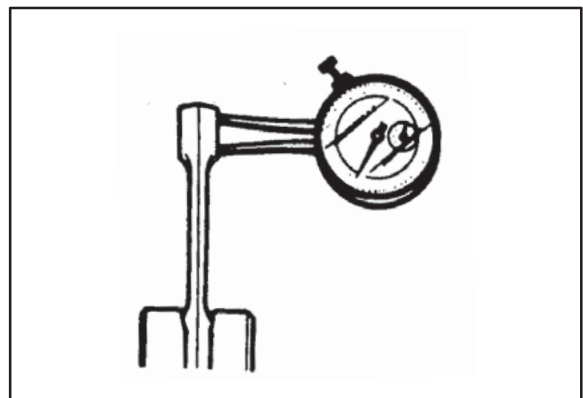

## ENGINE INSPECTION PROCEDURES, CONT.

### Reed Valve Inspection

1. Measure the air gap between fiber reed and reed block as shown. The air gap should not exceed .015" (.40 mm). If clearance is excessive DO NOT attempt to reverse the reeds to reduce the air gap. *Always replace them if damaged.* Check each fiber reed for stress marks or missing material.

**Reed Valve Air Gap**  
**Service Limit:**  
**.015" (0.4 mm)**

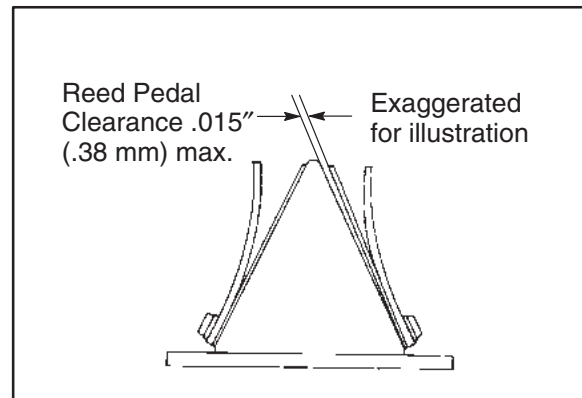

### Clutch Cover and Brake Lining

2. Inspect the condition of the clutch cover. Measure the inside diameter of the cover using a caliper. The inner diameter service limit is 4.43" (112.5 mm). Inspect the condition and diameter of the brake lining. The service limit of the lining is .039" (1.0 mm). If either of these measurements exceeds the limit, replace the clutch cover.

**Clutch Cover Inner Diameter**  
**Service Limit: 4.43" (112.5 mm)**

**Brake Lining**  
**Service Limit: .039" (1.0 mm)**

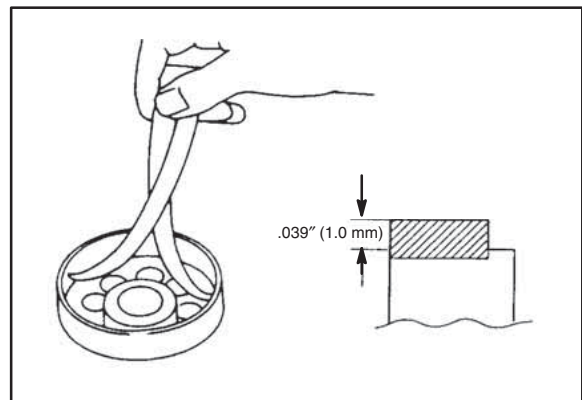

### Compression Spring

3. Use a vernier caliper to inspect the length of the compression spring. With the spring at full extension, the measurement should be no less than 2.74" (69.7 mm). If out of specification, replace spring.

**Compression Spring**  
**Service Limit:**  
**2.74" (69.7 mm)**

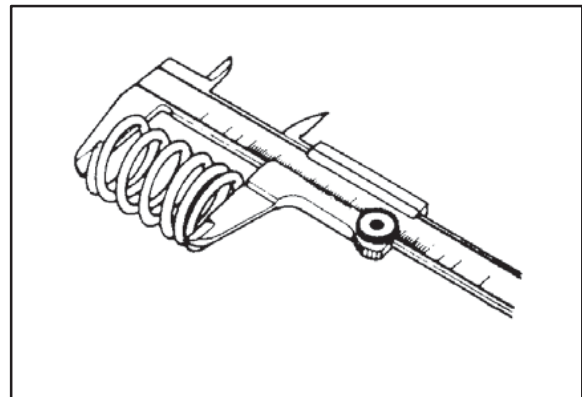

### Belt Inspection

4. Inspect the surface of the drive belt for uneven wear or grease deposits. Using a vernier caliper, measure the width of the belt. The service limit of the belt is .626" (15.9 mm). If the width of the belt is less than the service limit, or if the belt is worn, glazed or hourglassed, replace.

**Drive Belt Width**  
**Service Limit**  
**.626" (15.9 mm)**

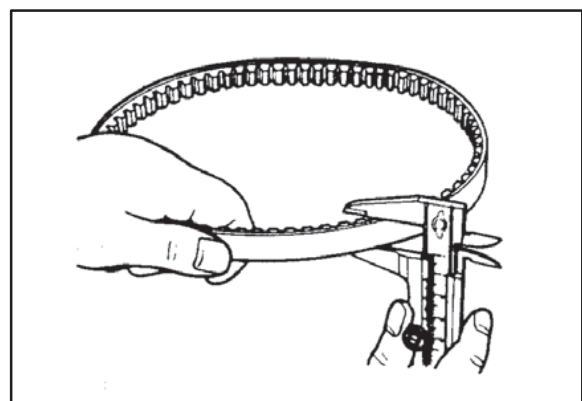

### CYLINDER HONE SELECTION/HONING PROCEDURE

Selecting a hone which will straighten as well as remove material from the cylinder is very important. Using a common spring loaded finger type glaze breaker for honing is never advised. Polaris recommends using a rigid hone or arbor honing machine which also has the capability of oversizing.

Cylinders may be wet or dry honed depending upon the hone manufacturer's recommendations. Wet honing removes more material faster and leaves a more distinct pattern in the bore.

**CAUTION:**

### HONING TO OVERSIZE

If cylinder wear or damage is excessive, it will be necessary to oversize the cylinder using a new oversize piston and rings. This may be accomplished by either boring the cylinder and then finish honing to the final bore size, or by rough honing followed by finish honing.

For oversize honing always wet hone using honing oil and a coarse roughing stone. Measure the piston (see piston measurement) and rough hone to the size of the piston. Always leave .002 - .003" (.05 - .07 mm) for finish honing. Refer to piston-to-cylinder clearance specifications on page 2.13 before honing. Complete the sizing with fine grit stones to provide the proper cross-hatch finish and required piston clearance.

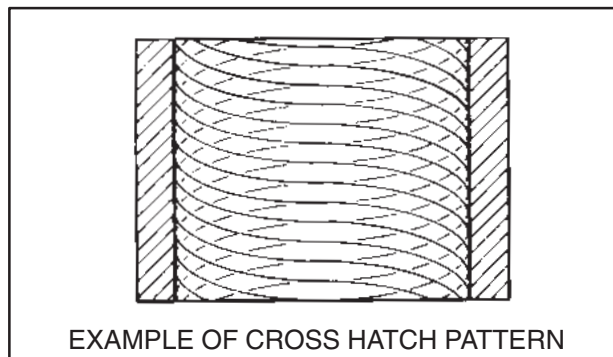

A finished cylinder should have a cross-hatch pattern to ensure piston ring seating and to aid in the retention of the fuel/oil mixture during initial break in. Hone cylinder according to hone manufacturer's instructions, or these guidelines:

- Use a motor speed of approximately 300-500 RPM, run the hone in and out of the cylinder rapidly until cutting tension decreases. Remember to keep the hone drive shaft centered (or cylinder centered on arbor) and to bring the stone approximately 1/2" (1.3 cm) beyond the bore at the end of each stroke.
- Release the hone at regular intervals and inspect the bore to determine if it has been cleared, and to check piston fit. **NOTE:** Do not allow cylinder to heat up during honing. The thinner areas of the liner around the ports will expand causing uneven bore.
- After honing has been completed inspect all port opening areas for rough or sharp edges. Apply a slight chamfer to all ports to remove sharp edges or burrs, paying particular attention to the corners of the intake and exhaust ports.

**IMPORTANT:**

### CLEANING THE CYLINDER AFTER HONING

It is very important that the cylinder be thoroughly cleaned after honing to remove all grit material. Wash the cylinder in a solvent, then in hot, soapy water. Pay close attention to areas where the cylinder sleeve meets the aluminum casting (transfer port area). Use electrical contact cleaner if necessary to clean these areas. Rinse thoroughly, dry with compressed air, and oil the bore immediately with Polaris 2 Cycle Lubricant.



## CRANKSHAFT RUNOUT

Lubricate the bearings and clamp the crankshaft securely in the holding fixture. Refer to the illustrations below.

**Crankshaft Alignment Fixture  
PN 2870569**

1. If the runout of the crankshaft is more than .004" (.100mm) on the MAG side, or .006" (.150mm) on the PTO side, the crankshaft must be replaced.

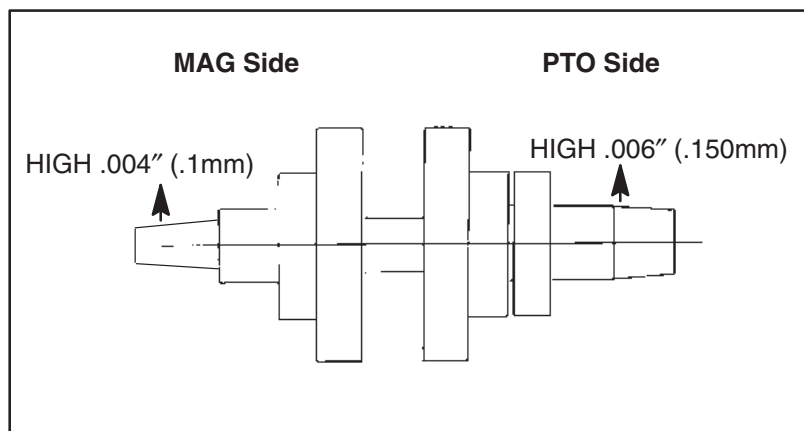

## ENGINE ASSEMBLY

### Crankcase

1. Install a new output shaft oil seal and replace the snap ring.

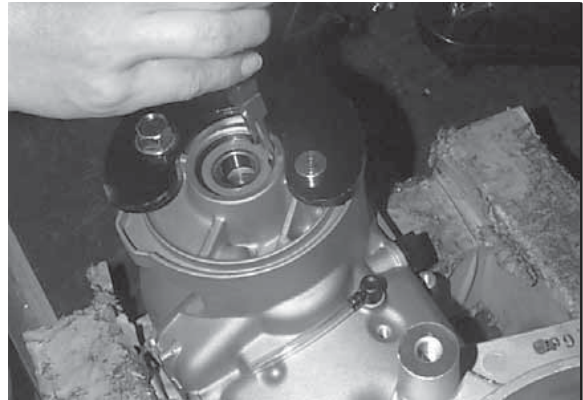

2. Install the crankshaft in one of the crankcase halves. Install a new crankcase gasket and install the other side of the crankcase. Torque the crankcase bolts to specification.

**Crankcase Bolt Torque:**

**86 in.lbs. (10 Nm)**

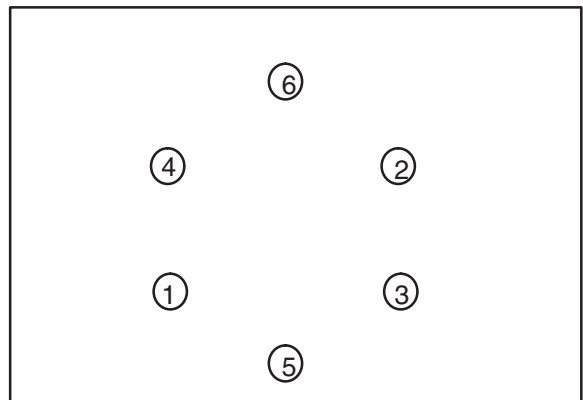

3. Install the oil pump bracket inside the MAG side of the crankcase.

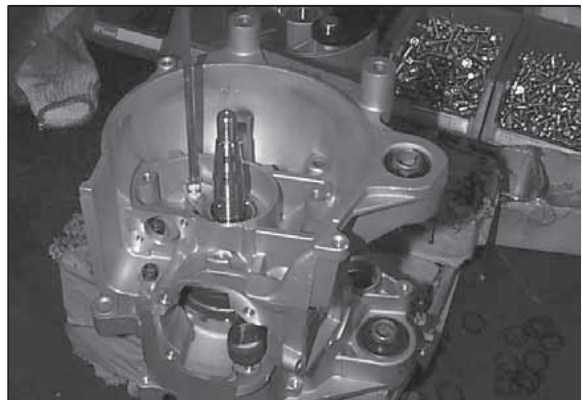

4. Install the oil pump drive gear and new external circlips.

## ENGINE ASSEMBLY

5. Make sure oil pump area is clean. Install oil pump and torque to specification. Install new stator gasket.

**Oil Pump Bolt Torque:**

**43 in.lbs. (5 Nm)**

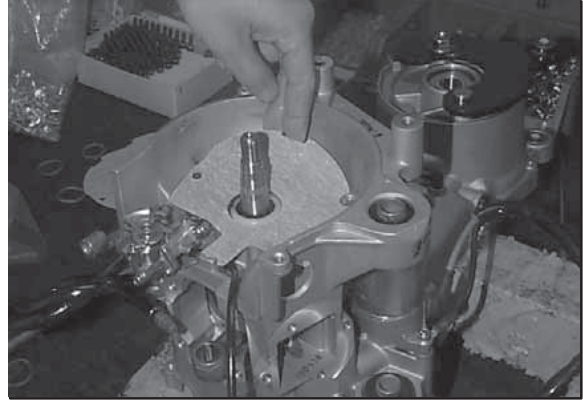

6. Install stator. Torque bolts to specification.

**Stator Mounting Bolt Torque:**

**84 in.lbs. (9.5 Nm)**

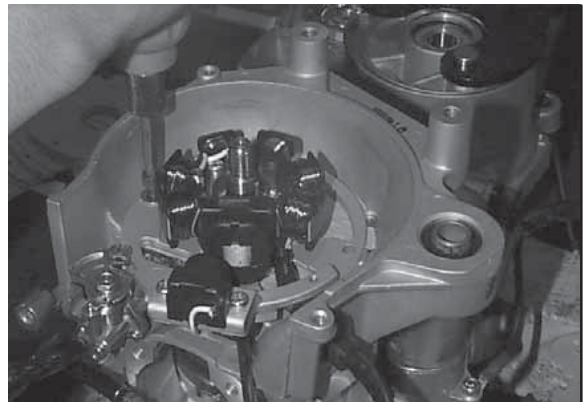

7. Inspect flywheel key for damage. Replace if necessary. Install flywheel and torque to specification.

**Flywheel Nut Torque:**

**25 ft.lbs. (34 Nm)**

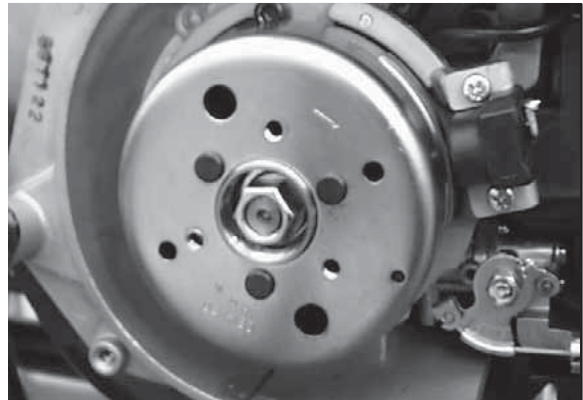

8. Install driven clutch shaft components and shaft assembly.

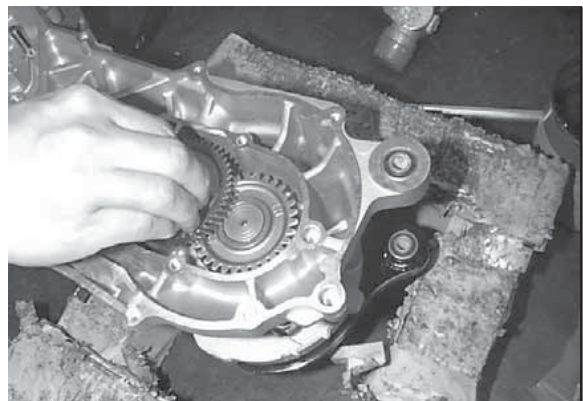

### ENGINE ASSEMBLY

9. Install new transmission cover gasket and install transmission cover. Torque bolts to specification.

**Transmission Cover Bolt Torque:**

**84 in.lbs. (9.5 Nm)**

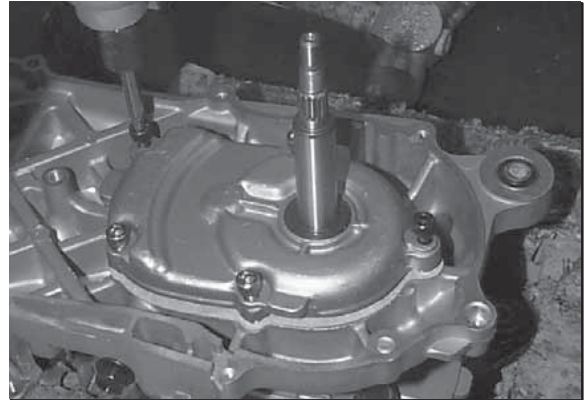

10. Add the specified amount of oil to the transmission gear case. Inspect for leaks.

**Gear Case Oil Specification:**

**10 fl.oz. (300 ml)**

**Polaris Premium Synthetic  
Gearcase Lubricant:  
PN 2871477 (Gallon)  
PN 2871478 (12 oz.)**



11. Install the starter clutch, starter gear, needle bearing, and washer.

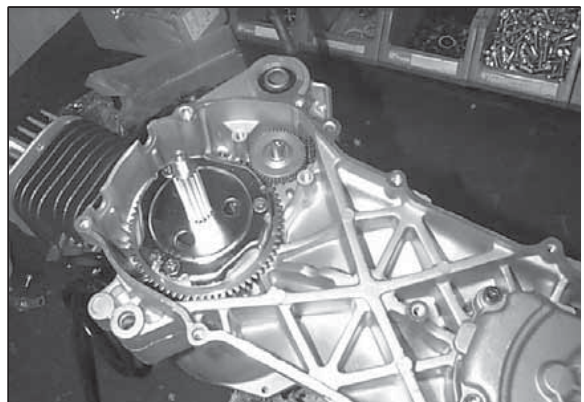

12. Install the plate, shaft pin, washers, and idler gear.

13. Install idle gear bolts and torque to specification.

**Idler Gear Bolt Torque:**

**84 in.lbs. (9.5 Nm)**

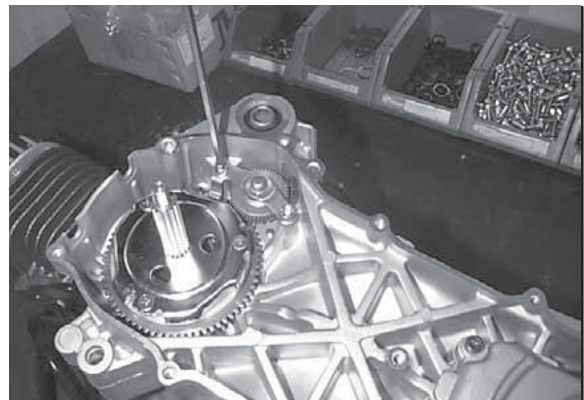

## ENGINE ASSEMBLY

14. Install oil ring, driven clutch, and driven clutch nut on output shaft. Torque nut to specification

**Driven Clutch Nut Torque:**

**25 ft.lbs. (34 Nm)**



15. Install primary clutch sheave.

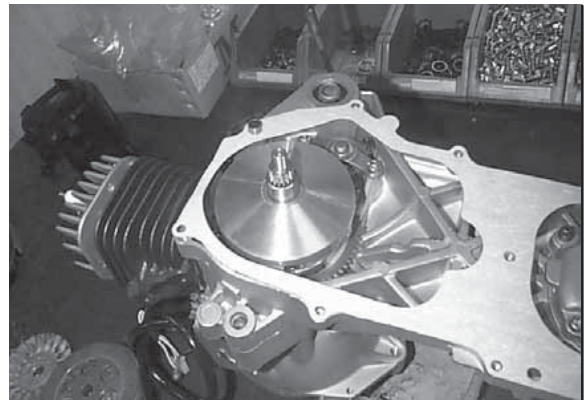

16. Install drive belt.

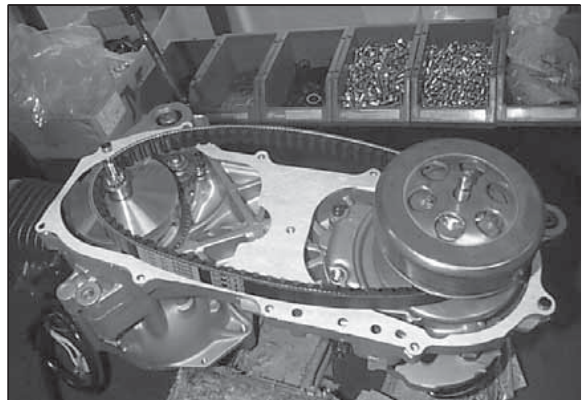

17. Install the primary fixed sheave and claw washer.

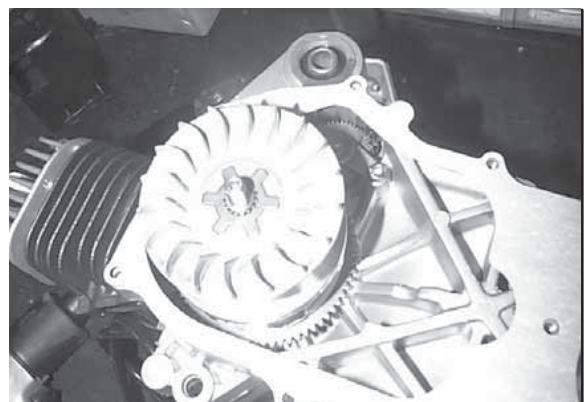

### ENGINE ASSEMBLY

18. Install drive clutch bolt and torque to specification.

**Drive Clutch Nut Torque:**

**29 ft.lbs. (39 Nm)**

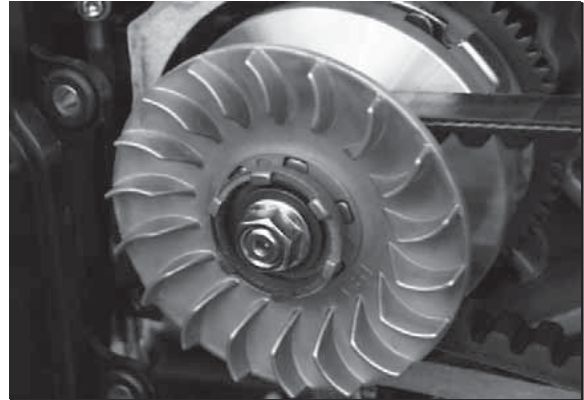

19. Install new gasket, bolts, grommets, protectors, filter and install carburetor tube bracket and crankcase cover (Sportsman 90 and Scrambler 90). Torque cover bolts to specification.

**Transmission Cover Bolt Torque:**

**84 in.lbs. (9.5 Nm)**

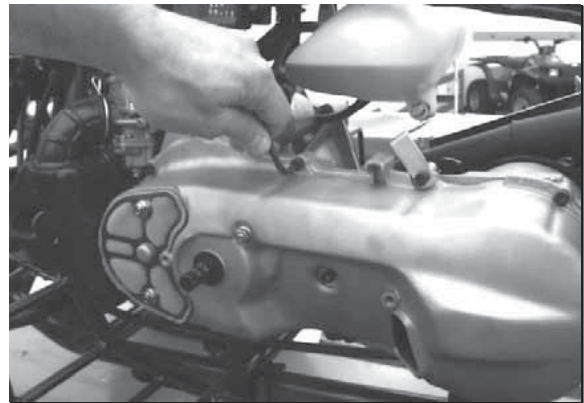
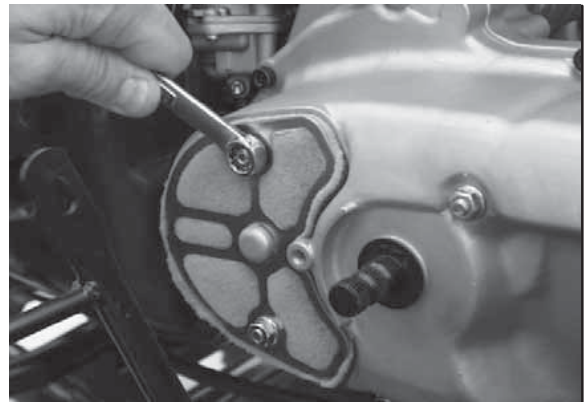

20. Install new gasket, bolts grommets, protectors, filter, and install carburetor tube bracket and cover (Scrambler 50). Torque cover bolts to specification.

**Transmission Cover Bolt Torque:**

**84 in.lbs. (9.5 Nm)**

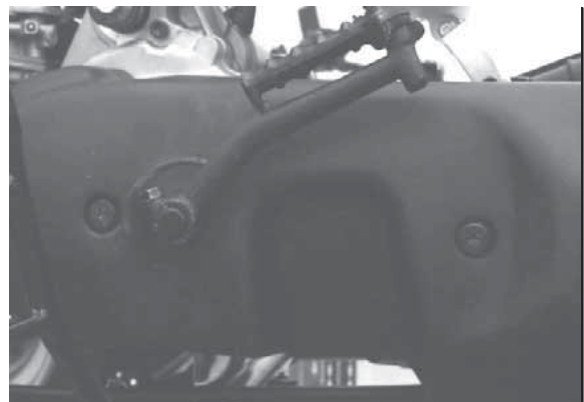

## ENGINE ASSEMBLY

21. Install small end bearing into connecting rod.

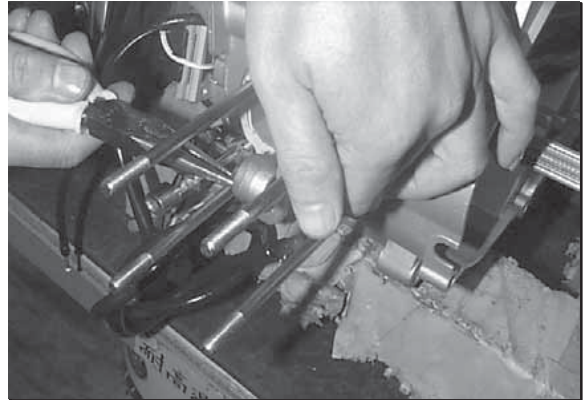

22. Carefully install new piston rings so no damage is done to the piston or ring lands.

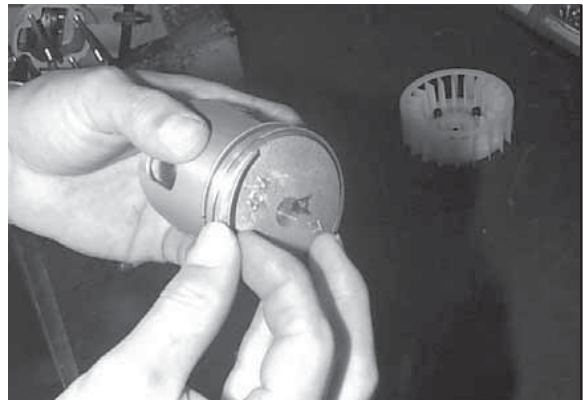

23. Install new base gasket and carefully install new piston and piston pin. Use care not to damage parts.



24. Install new circlips.



### ENGINE ASSEMBLY

25. Make sure cylinder is clean and free of debris. Install cylinder carefully making sure the piston rings are in the correct position.

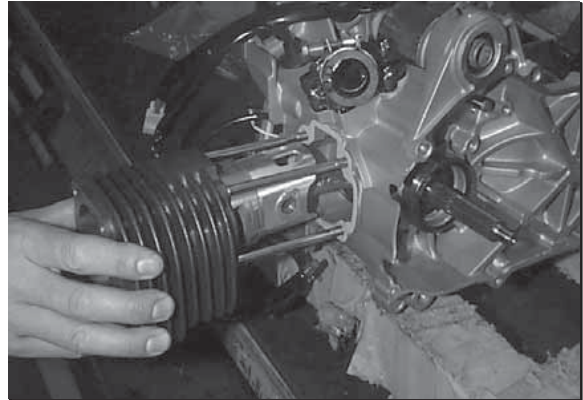

26. Install a new head gasket and install head. Torque the cylinder head in a criss-cross pattern to specification.

**Cylinder Head Nut Torque:**

**14 ft.lbs. (19 Nm)**

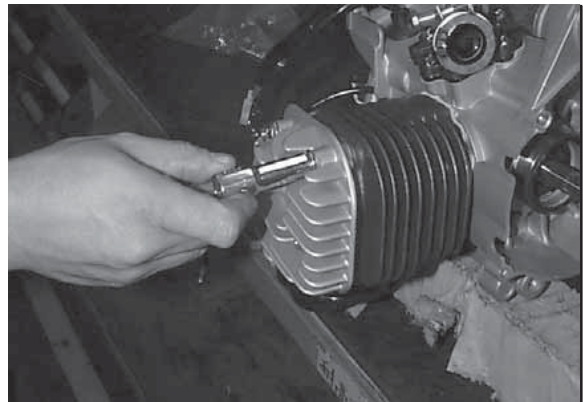

27. Install new spark plug. Spark plug gap should be .024-.028" (.6-.7 mm).

**Spark Plug Gap:**

**.024-.028" (.6-.7 mm)**

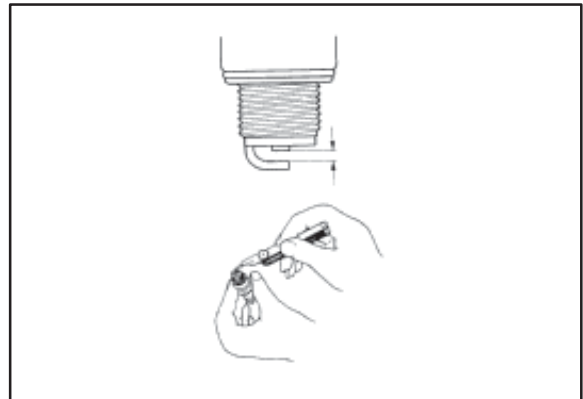

28. Install intake manifold and reed valve. Install bolts securing the intake manifold. Torque to specification.

**NOTE:** Remove any remaining gasket material from the reed valve housing and crankcase. Always replace the reed valve gasket when removing.

**NOTE:** Check the condition of the reed. If petals look damaged in any way, replace.

**Intake Manifold Bolt Torque:**

**108 in.lbs. (12 Nm)**

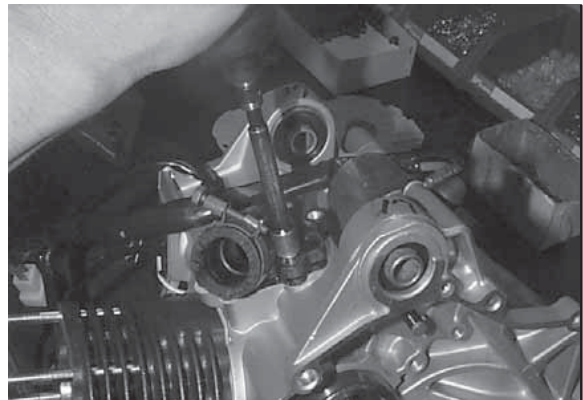



## ENGINE ASSEMBLY

29. Install carburetor and tighten the carburetor adaptor screw to specification.

**Carburetor Adaptor Screw Torque:**  
**20 in.lbs. (2.25 Nm)**

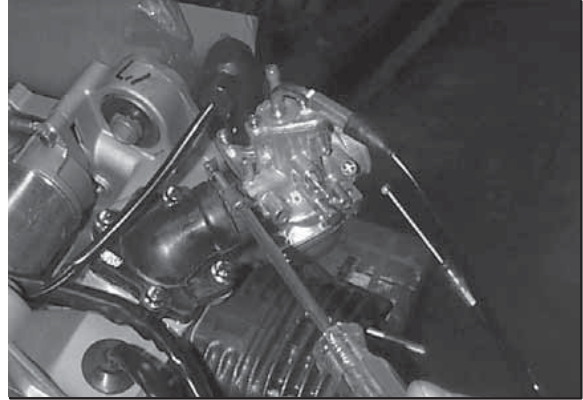

30. Install air duct to carburetor.

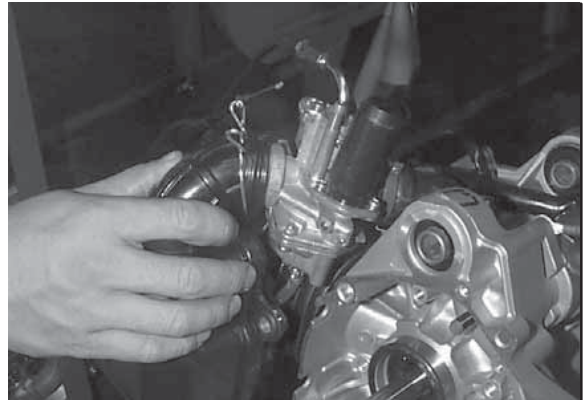

31. Install starter motor. Torque bolts to specification.

**Starter Motor Bolt Torque:**  
**84 in.lbs. (9.5 Nm)**

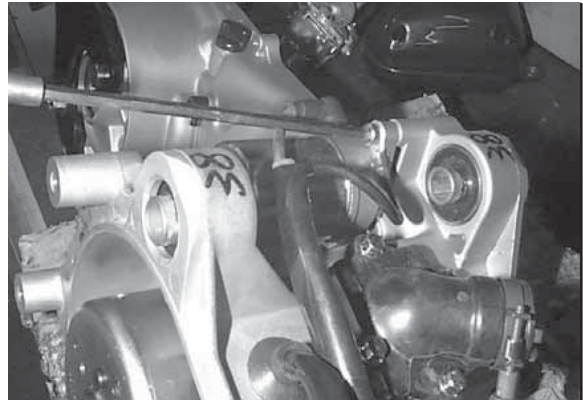

32. Install fan. Torque fan bolts to specification.

**Fan Bolt Torque:**  
**84 in.lbs. (9.5 Nm)**

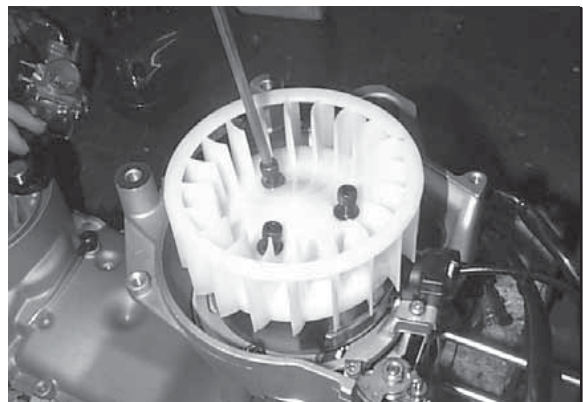

### ENGINE ASSEMBLY

33. Install cylinder air shroud and deflector.

**Cylinder Air Shroud and Deflector  
Screw Torque:**

**84 in.lbs. (9.5 Nm)**

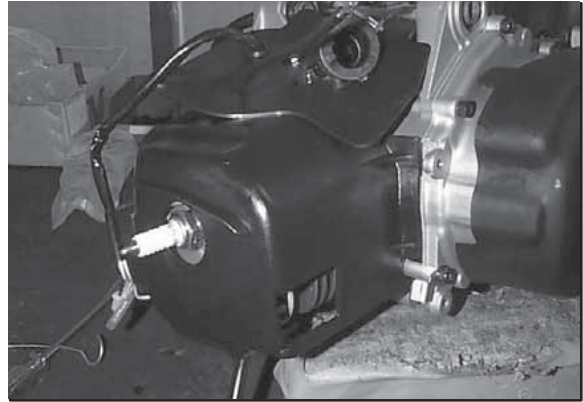

34. Install fasteners on fan cover and torque bolts to specification.

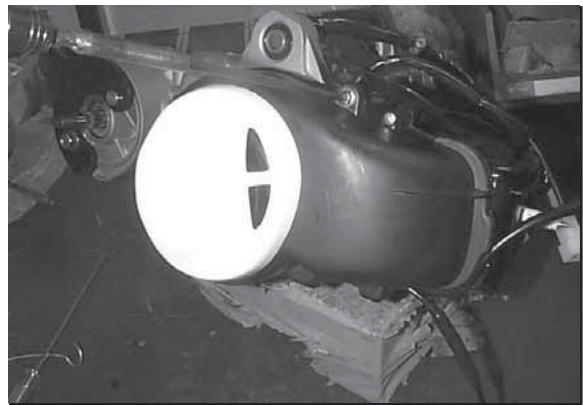

## **SPARK PLUG FOULING**

- Spark plug cap loose or faulty
- Choke cable adjustment or plunger/cable sticking
- Foreign material on choke plunger seat or plunger
- Incorrect spark plug heat range or gap
- Carburetor inlet needle and seat worn or leaking
- Jet needle and/or needle jet worn or improperly adjusted
- Excessive carburetor vibration (loose or missing needle jet locating pins)
- Loose jets in carburetor or calibration incorrect for altitude/temperature
- Incorrect float level setting
- PVT system calibrated incorrectly or components worn or mis-adjusted
- Fuel quality poor (old) or octane too high
- Low compression
- Restricted exhaust
- Weak ignition (loose coil ground, faulty coil, stator, or ETC switch)
- ETC switch mis-adjusted
- Restricted air filter (main or pre-cleaner) or breather system
- Improperly assembled air intake system
- Restricted engine breather system
- Oil contaminated with fuel
- Restricted oil tank vent

## TROUBLESHOOTING

### **Engine Turns Over But Fails to Start**

- No fuel
- Dirt in fuel line or filter
- Fuel will not pass through fuel valve
- Fuel pump inoperative/restricted
- Tank vent plugged
- Carb starter circuit
- Engine flooded
- Low compression (high cylinder leakage)
- No spark (Spark plug fouled)

### **Engine Does Not Turn Over**

- Dead battery
- Starter motor does not turn
- Engine seized, rusted, or mechanical failure

### **Engine Runs But Will Not Idle**

- Restricted carburetor pilot system
- Carburetor misadjusted
- Choke not adjusted properly
- Low compression
- Crankcase breather restricted

### **Engine Idles But Will Not Rev Up**

- Spark plug fouled/weak spark
- Broken throttle cable
- Obstruction in air intake
- Air box removed (reinstall all intake components)
- Incorrect or restricted carburetor jetting
- Incorrect ignition timing
- Restricted exhaust system

### **Engine Has Low Power**

- Spark plug fouled
- Cylinder, piston, ring, wear or damage (check compression)
- PVT not operating properly
- Restricted exhaust muffler
- Dirty carburetor

### **Piston Failure - Scoring**

- Lack of lubrication
- Dirt entering engine through cracks in air filter or ducts

## **TROUBLESHOOTING, CONT**

### **Excessive Smoke and Carbon Buildup**

- Excessive piston-to-cylinder clearance
- Worn rings, piston, or cylinder
- Air filter dirty or contaminated

### **Low Compression**

- Cylinder head gasket leak
- Cylinder or piston worn
- Piston rings worn, leaking, broken, or sticking

### **Backfiring**

- Fouled spark plug or incorrect plug or plug gap
- Carburetion faulty - lean condition
- Exhaust system air leaks
- Ignition system faulty:
  - Spark plug cap cracked/broken
  - Ignition coil faulty
  - Ignition or kill switch circuit faulty
  - Ignition timing incorrect
  - Sheared flywheel key
- Poor connections in ignition system
- System wiring wet
- Lean condition

### **Overheating**

- Lean mixture (restricted jets, vents, or fuel valve)
- Dirt in cooling fins
- Ignition timing misadjusted
- Spark plug incorrect heat range



# ***CHAPTER 3***

## ***FUEL SYSTEM/CARBURETION***

Fuel System Warnings .....	3.1
Carburetor Operation .....	3.2
Float System .....	3.2
Pilot Jet / Pilot Air Screw / Air/Fuel Mixture .....	3.3
Jet Needle / Needle Jet / Throttle Opening .....	3.4
Throttle Valve / Main Jet .....	3.5
Pilot System .....	3.6
Slide Cutaway / 1/8-3/8 Throttle .....	3.7
Jet Needle / Needle Jet / 3/8-3/4 Throttle .....	3.8
Main System / 3/4 to Full Throttle .....	3.9
Fuel Delivery .....	3.10
Vent Systems / Float Height .....	3.11
Needle and Seat Leakage Test .....	3.11
Carburetor Float Bowl Draining .....	3.12
Carburetor Exploded View .....	3.13
Troubleshooting .....	3.14-3.15











## **FUEL SYSTEM**

**⚠ WARNING**

*Gasoline is extremely flammable and explosive under certain conditions.*

-  Always stop the engine and refuel outdoors or in a well ventilated area.
-  Do not smoke or allow open flames or sparks in or near the area where refueling is performed or where gasoline is stored.
-  Do not overfill the tank. Do not fill the tank neck.
-  If you get gasoline in your eyes or if you swallow gasoline, see your doctor immediately.
-  If you spill gasoline on your skin or clothing, immediately wash it off with soap and water and change clothing.
-  Never start the engine or let it run in an enclosed area. Gasoline powered engine exhaust fumes are poisonous and can cause loss of consciousness and death in a short time.
-  Never drain the float bowl when the engine is hot. Severe burns may result.

### CARBURETOR OPERATION

The function of a carburetor is to produce a combustible air/fuel mixture by breaking fuel into tiny particles in the form of vapor, to mix the fuel with air in a proper ratio, and to deliver the mixture to the engine. A proper ratio means an ideal air/fuel mixture which can burn without leaving an excess of fuel or air. Whether the proper mixture ratio is maintained or not is the key to efficient engine operation.

The engine of a vehicle is operated under a wide range of conditions, from idling with the throttle valve remaining almost closed, to full load or maximum output with the throttle valve fully opened. In order to meet the requirements for the proper mixture ratio under these varying conditions, a low speed fuel system, or pilot system, and a main fuel system are provided in these type of carburetors.

This carburetor has varying operations depending upon varying driving conditions. It is constructed of a float system, pilot system, main system, and starter system or initial starting device.

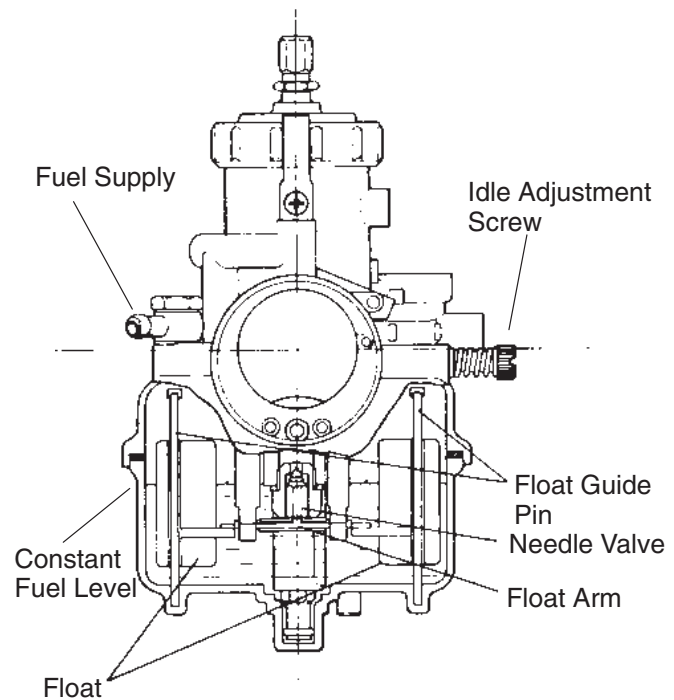

### FLOAT SYSTEM

The float system is designed to maintain a constant height of gasoline during operation. When the fuel flowing from the fuel pump into the float chamber through the needle valve reaches the constant fuel level, the floats rise. When the buoyancy of the float and the fuel pressure of the fuel pump balance, the needle valve seals the orifice in the needle seat, preventing further fuel delivery, and the level of fuel in the bowl remains relatively constant.

The fuel level in the bowl assists in controlling the amount of fuel in the fuel mixture. Too high a level allows more fuel than necessary to leave the nozzle, enriching the mixture. Too low a level results in a leaner mixture, since not enough fuel leaves the nozzle. Therefore, the predetermined fuel level should not be changed arbitrarily.

## PILOT JET

From idling to low speeds, the fuel supply is metered by the pilot jet. There are several air bleed openings in the sides of the pilot jet which reduce the fuel to mist. The number stamped on the jet is an indication of the amount of fuel in cc's which passes through the jet during a one minute interval under a given set of conditions.

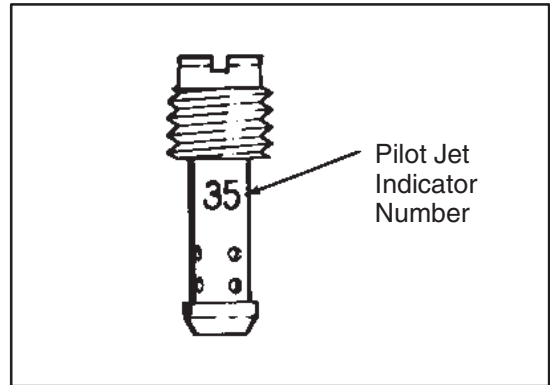

## PILOT AIR SCREW

The pilot air screw controls the fuel mixture from idle to low speeds. The tapered tip of the air screw projects into the air passage leading to the pilot jet air bleeds. By turning the screw in or out, the cross sectional area of the air passage is varied, in turn varying the pilot jet air supply and changing the mixture ratio.

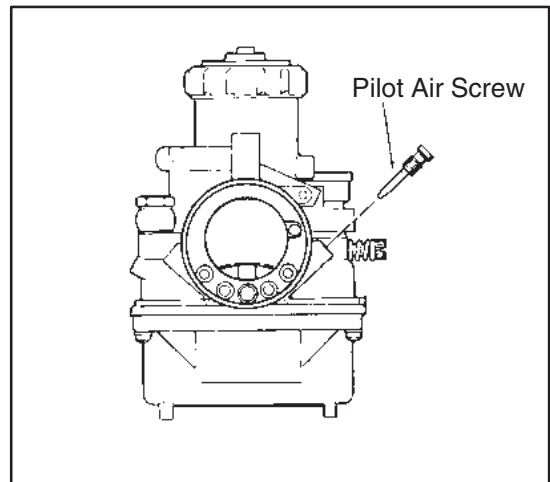

## AIR/FUEL MIXTURE RATIO

A carburetor with a piston type throttle valve is also called a variable venturi type carburetor. In this type of carburetor, the needle jet and jet needle serve to control a proper air/fuel mixture ratio at the medium throttle valve opening (between 1/4 and 3/4 opening). Having the proper needle jet and jet needle has a major impact on engine performance at partial load.

The jet needle tapers off at one end and the clearance between the jet needle and the needle jet increases as the throttle valve opening gets wider. The air/fuel mixture ratio is controlled by the height of the "E" ring inserted into one of the five slots provided in the head of the jet needle. The chart at right shows the variation of fuel flow based on the height of the "E" ring.

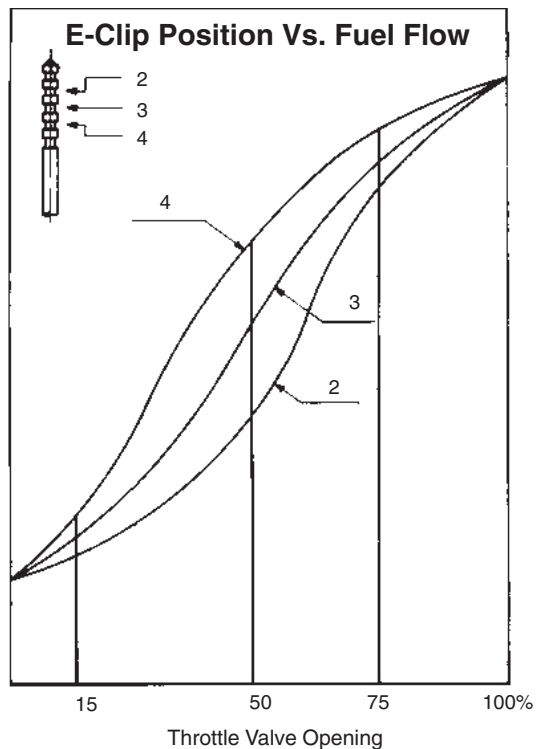

## JET NEEDLE

The jet needle has five adjustment grooves cut into the upper portion, and is tapered from approximately the middle of the needle to the lower end. The top is fixed to the center of the throttle valve by the needle clip, and the tapered end extends into the needle jet. Fuel flows through the space between the needle jet and jet needle. This space does not vary until the throttle reaches the 1/4 open point. At that time the tapered portion of the needle begins to move out of the jet, affecting fuel flow as the opening enlarges. If the needle clip is changed from the standard position to a lower groove, the needle taper starts coming out of the jet sooner, resulting in a richer mixture. Moving the clip higher produces a leaner mixture. If the taper is worn due to vibration, fuel flow may be significantly affected.

## NEEDLE JET

The needle jet works in conjunction with the jet needle to regulate fuel flow rate. An air bleed opening in the side of the needle jet brings in air measured by the air jet. This air initiates the mixing and atomizing process inside the needle jet. Mixing is augmented by a projection at the needle jet outlet, called the primary choke. The letter number code stamped on the jet indicates jet inside diameter.

## THROTTLE OPENING VS. FUEL FLOW

In a full throttle condition the cross sectioned area between the jet needle and the needle jet is larger than the cross sectioned area of the main jet. The main jet therefore has greater control over fuel flow.

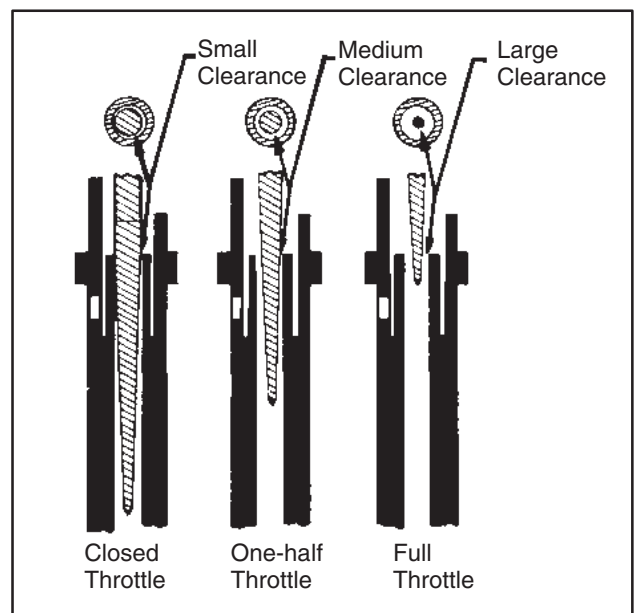
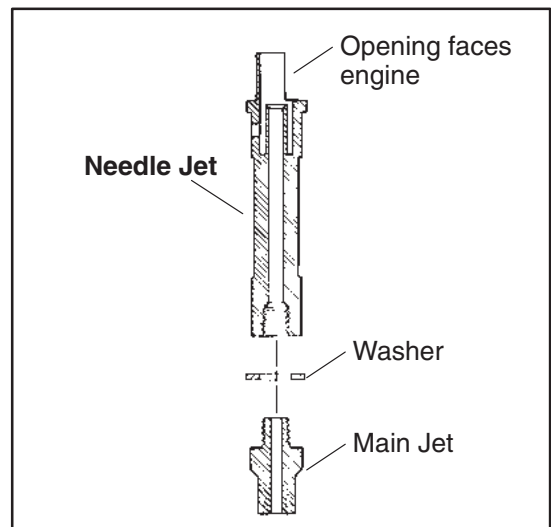
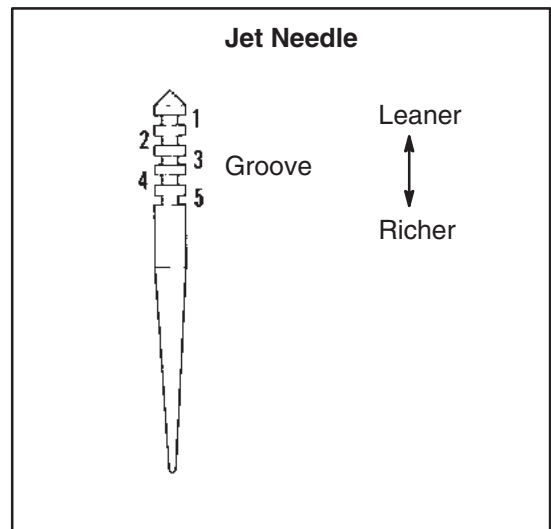

## THROTTLE VALVE

The throttle valve controls the rate of engine air intake by moving up and down inside the main bore. At small throttle openings, air flow control is performed chiefly by the cutaway. By controlling air flow the negative pressure over the needle valve is regulated, in turn varying the fuel flow.

The throttle valves are numbered 1.0, 1.5, 2.0, etc., according to the size of the cutaway. The higher the number, the leaner the gasoline/air mixture.

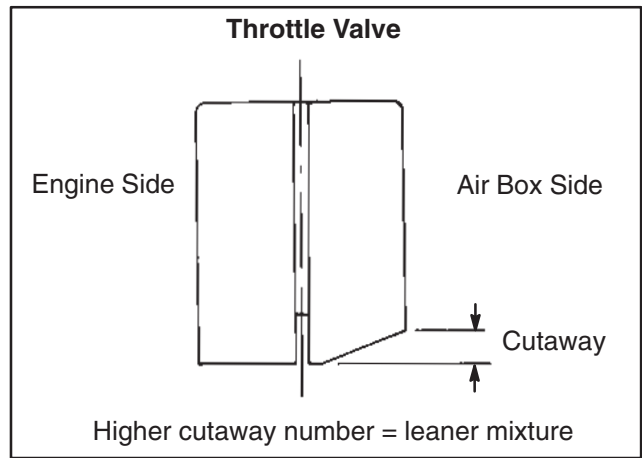

## MAIN JET

When the throttle opening becomes greater and the area between the needle jet and jet needle increases, fuel flow is metered by the main jet. The number on the jet indicates the amount of fuel CCs which will pass through it in one minute under controlled conditions. Larger numbers give a greater flow, resulting in a richer mixture.

Main jets are screwed directly into the needle jet base.

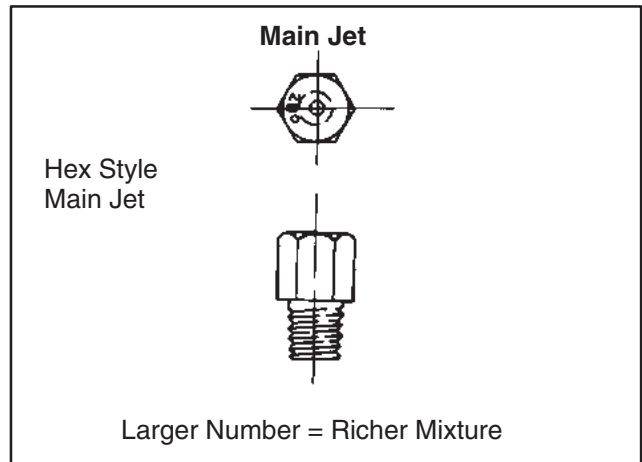

### PILOT SYSTEM (0-3/8 THROTTLE)

The pilot system's main function is to meter fuel at idle and low speed driving. Though its main function is to supply fuel at low speed, it does feed fuel continuously throughout the entire operating range.

Fuel for the pilot jet is drawn from the float bowl, mixed with air regulated by the air screw, and delivered to the engine through the pilot outlet.

The mixture is regulated to some degree by adjusting the air screw. When the air screw is closed, the fuel mixture is made richer as the amount of air is reduced. When the air screw is opened, the mixture is made more lean as the amount of air is increased.

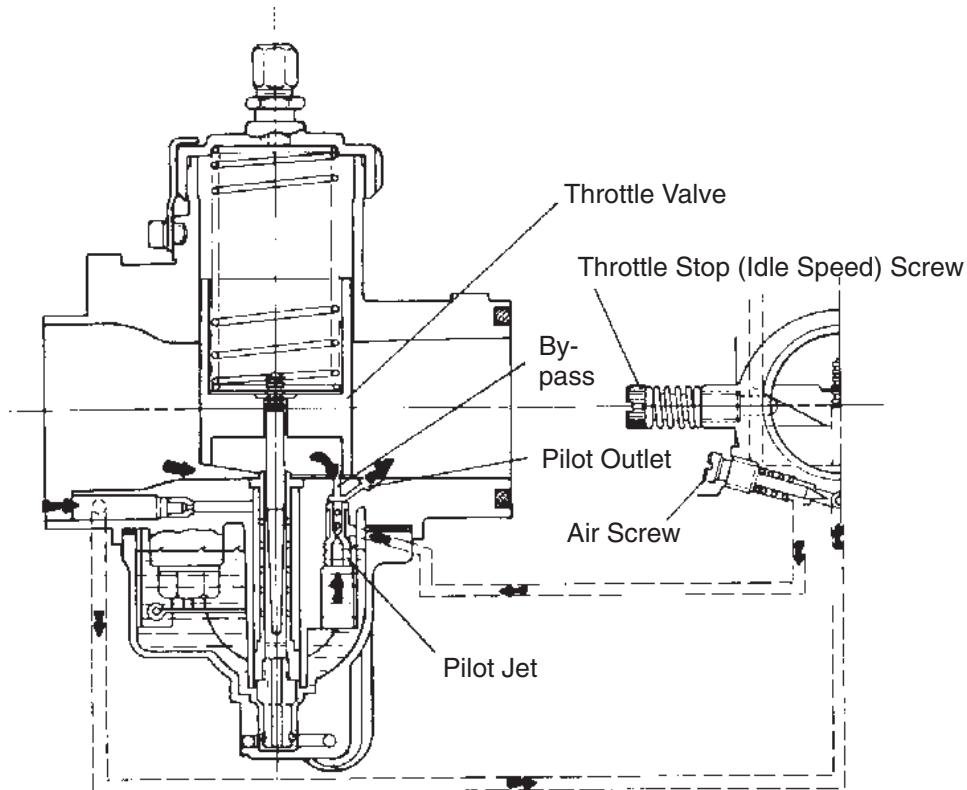

**SLIDE CUTAWAY (1/8-3/8 THROTTLE)**

Throttle valve cutaway effect is most noticeable at 1/4 throttle opening. The amount of cutaway is pre-determined for a given engine to maintain a 14:1 air/fuel ratio at part throttle. A steep angle would indicate a fairly lean mixture because there is less resistance to air flow. A flat angle would provide a much richer mixture because there is more resistance to air flow. The venturi shape can be adjusted for each engine's breathing characteristics by using a different valve cutaway angle. A number will be stamped into the bottom of the valve (e.g. 2.5) indicating the size of the cutaway. The higher the number, the steeper the angle.

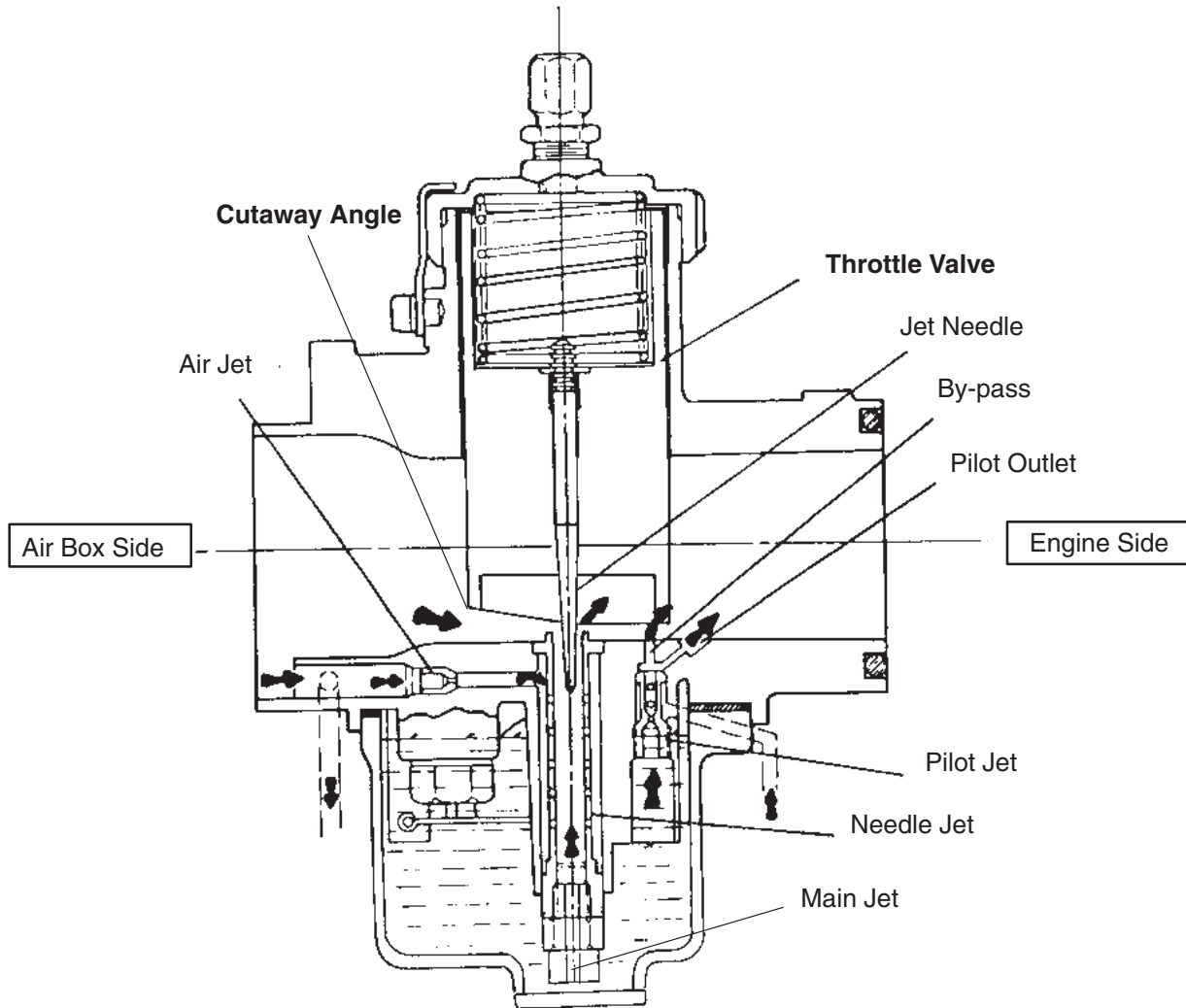

## JET NEEDLE/NEEDLE JET (3/8-3/4 THROTTLE)

The jet needle and needle jet have the most effect between 3/8 and 3/4 throttle opening. Some mixture adjustment can be accomplished by changing the location of the "E" clip on the needle. Moving the clip down raises the needle in the jet passage and richens the mixture. Moving the clip up lowers the needle in the jet passage and leans the mixture. Letter and number codes are stamped into the needle and the jet indicating sizes and tapers of each.

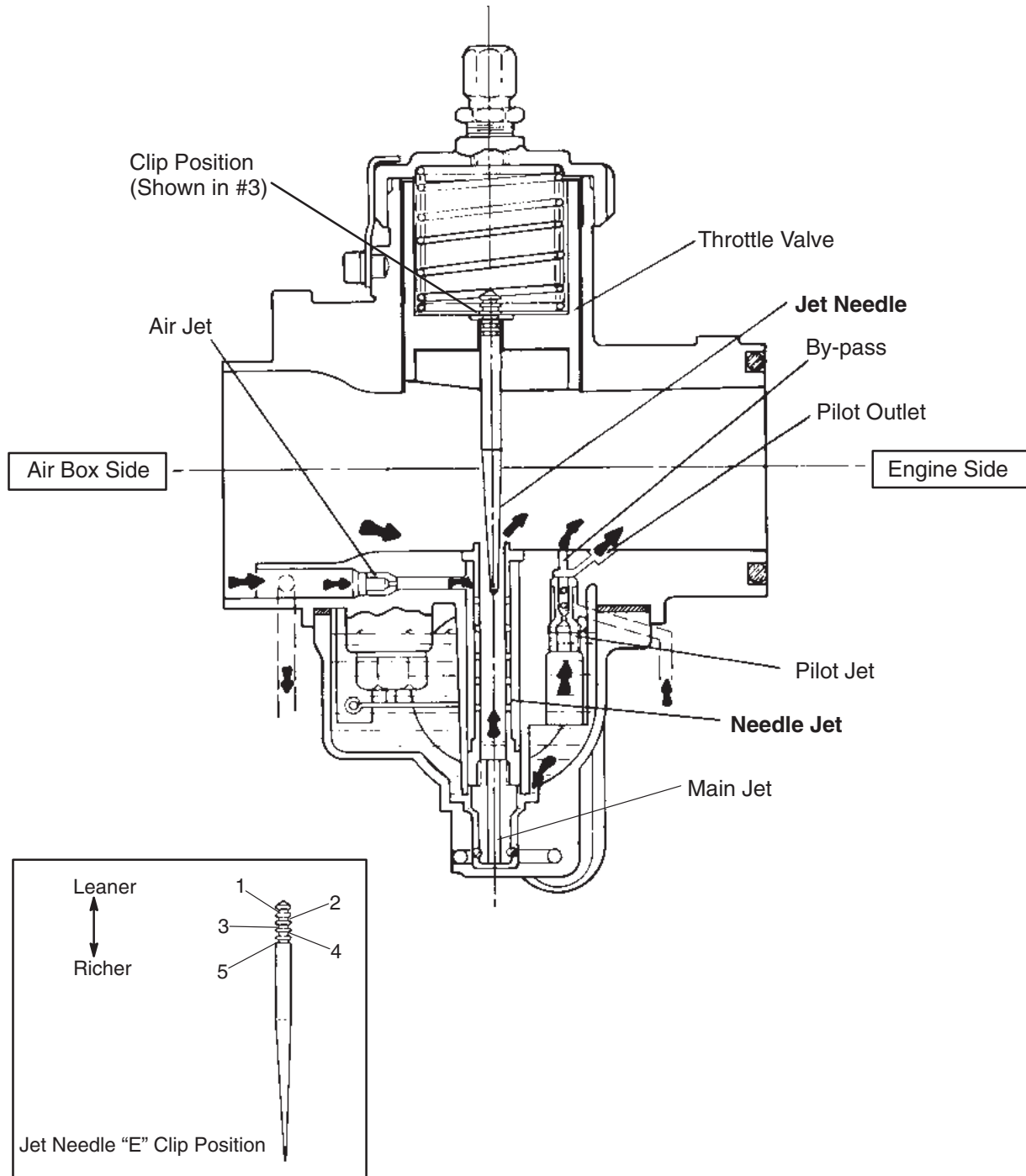



## MAIN SYSTEM (3/4 TO FULL THROTTLE)

The main system is designed for delivering fuel between low speed and high speed operation. This system is made up of the jet needle, needle jet, and main jet. The main system begins to take effect as soon as there is enough air flow into the carburetor venturi to draw fuel up through the main jet and needle jet assembly. This system works in conjunction with the needle jet system.

During low speed driving, there is very little clearance between the jet needle and the needle jet; therefore, very little fuel from the main jet can pass between the jet needle and the needle jet. As the throttle valve opening is increased, the tapered jet needle is raised farther out of the needle jet, allowing greater fuel flow. Under full throttle opening, the cross sectioned area of clearance between the jet needle and the needle jet becomes greater than the cross sectioned area of the main jet. Thus the main jet is now controlling the amount of fuel flow.

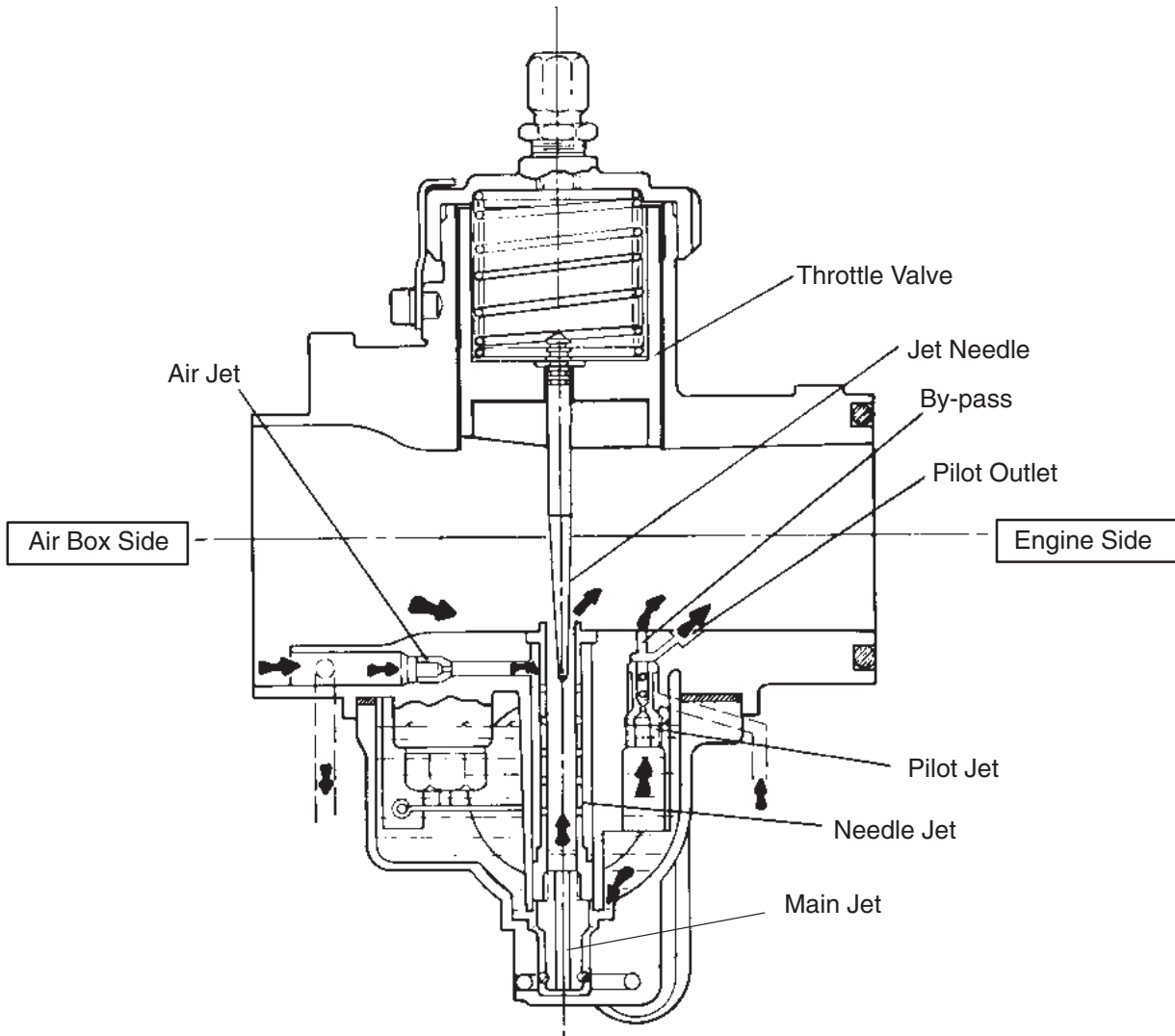

## FUEL DELIVERY (2 CYCLE)

The throttle opening chart below demonstrates component relationship to fuel flow versus throttle valve opening. The pilot system's main function is that of a low speed jet. Its most effective range of fuel delivery is from idle to approximately 3/8 throttle valve opening.

The throttle valve controls the rate of engine air by its movement up and down in the carburetor venturi. At small throttle openings the air flow is regulated chiefly by the valve cutaway, with greatest effectiveness at 1/4 throttle opening. Throttle valves are numbered 1.0, 1.5, 2.0, etc., according to the size of the cutaway. Decreasing the cutaway number will increase the amount of fuel delivered in its effective range.

The jet needle and needle jet have an effective operating range from approximately 1/8 to 7/8 throttle opening. The amount of fuel delivered during this range relies upon the jet needle clip position, as well as the needle jet size and other specifications.

The main jet affects fuel delivery at 1/4 throttle and consistently increases to full throttle opening.

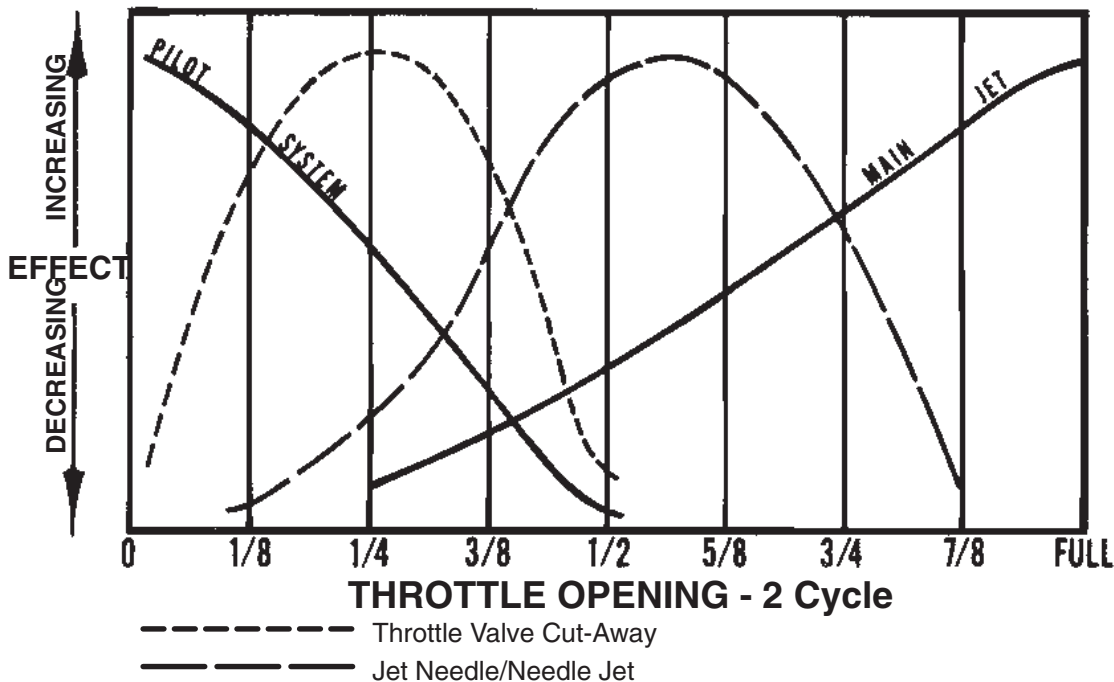

Carburetor Component Function - 2 Cycle			
System	Main Components	Main Function	Main Affect
Float System (Fuel Level Control)	Inlet Pipe, Needle and Seat, Floats, Float Pins	Maintains specified fuel level in float chamber (carburetor float bowl)	All systems All throttle ranges
Venting	Vent Passages in Carburetor, Vent line	Supplies atmospheric pressure to fuel in float chamber	All systems All throttle ranges
Starter (Choke/Enrichment)	Choke Lever, Cable, Choke Plunger, Return Spring, Carb Passages (Starter Jet, passage in float bowl)	Supplies additional fuel air mixture necessary for cold starting	All throttle ranges Greatest effect at low throttle settings and idle speeds
Pilot (Idle System)	Pilot Jet/Passageways, Pilot Air Screw with Spring, Bypass Port (Beneath Throttle Slide), Air Jet, Pilot Outlet, Throttle Valve Cutaway	Primarily supplies fuel at idle and low throttle settings	Mainly idle to 1/4 throttle Minimal effect after 1/2 throttle
Main System	Main Jet, Main Air Passage, Needle Jet, Jet Needle, Throttle Valve	Supplies fuel at mid-range and high throttle settings.	1/4 to full throttle

## VENT SYSTEMS

The fuel tank and carburetor float bowl vent lines supply atmospheric pressure to the fuel in the tank and float bowl. The lines must be free of kinks and restrictions to prevent lean mixture and possible engine damage. Vent lines must be properly routed to prevent damage to the line and to prevent contaminants from entering the carburetor or fuel tank.

## FLOAT HEIGHT

1. Invert the carburetor and remove float bowl.
2. Rest the float tongue lightly on the inlet needle valve pin without compressing the spring.
3. Measure height from float bowl mating surface to float arm as shown. Both sides of float arm must be parallel to each other. Use float adjustment tool (PN 2872314) or a vernier caliper. When measuring height, be sure inlet needle valve spring is not compressed. If adjustment is necessary, bend the tongue slightly.

**Float Height:**

**Parallel to Gasket Surface  $\pm 1$ mm**

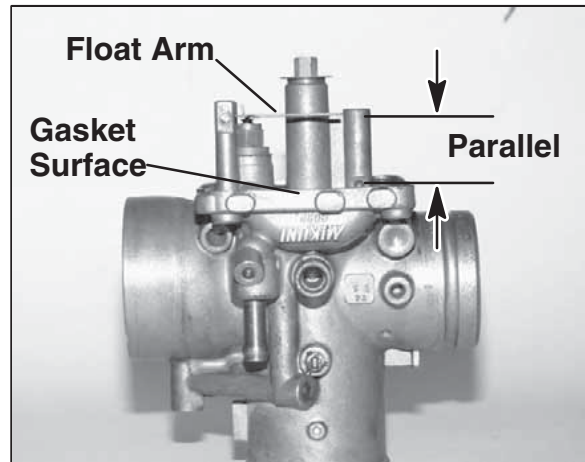

## NEEDLE AND SEAT LEAKAGE TEST

1. Install the float bowl. Invert the carburetor and install a Mity-Vac™ (PN 2870975) to the fuel inlet fitting. Apply 5 PSI pressure to inlet fitting. The needle and seat should hold pressure indefinitely. If not, inspect needle and seat and seat O-ring or gasket.

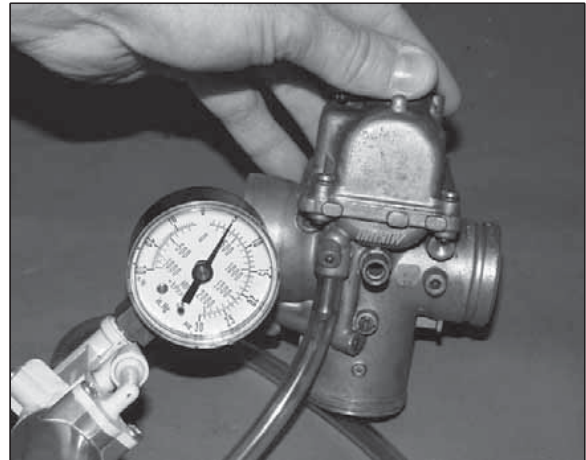

### CARBURETOR FLOAT BOWL DRAINING

The carburetor float bowl should be drained periodically to remove moisture or sediment from the bowl, or before extended periods of storage.

**NOTE:** A drain plug is located on the side of the float bowl.

1. Turn fuel valve to the off position.
2. Place a clean container beneath the bowl drain spigot or bowl drain hose.
3. Loosen drain plug and allow fuel in the float bowl and fuel line to drain completely.
4. Inspect the drained fuel for water or sediment.
5. Tighten drain plug.
6. Turn fuel valve to "on".
7. Inspect carburetor for fuel leaks.
8. Start machine and re-check for leaks.

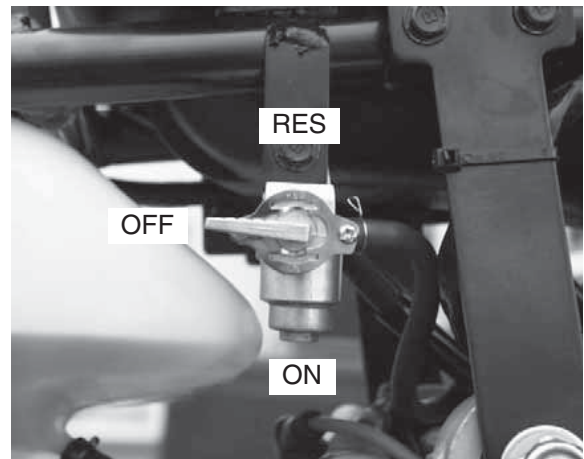
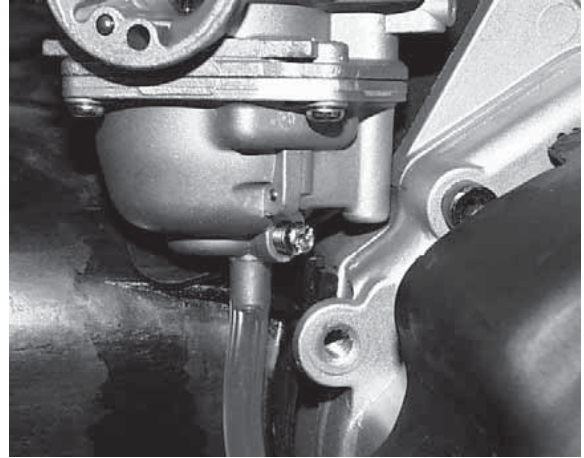

## Carburetor Exploded View

Jet Needle "E"  
Clip Position

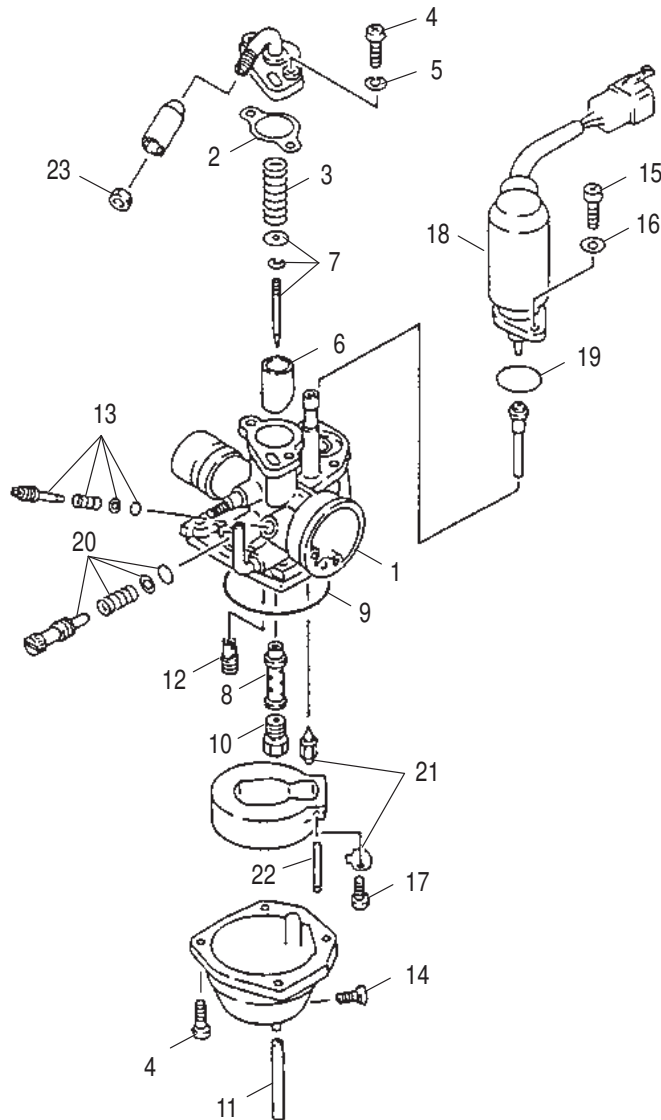
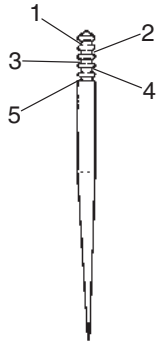

1. Carburetor Assembly
2. Gasket
3. Throttle Spring
4. Bolt
5. Washer
6. Valve, Throttle
7. Jet Needle
8. Needle Jet
9. Seal, Float Chamber
10. Main Jet
11. Overflow Tube
12. Pilot Jet
13. Pilot Air Screw
14. Drain Plug
15. Bolt
16. Washer
17. Bolt
18. Starter Plunger
19. O-ring
20. Throttle Screw
21. Needle and Seat
22. Float Pin
23. Cable Adjuster Nut

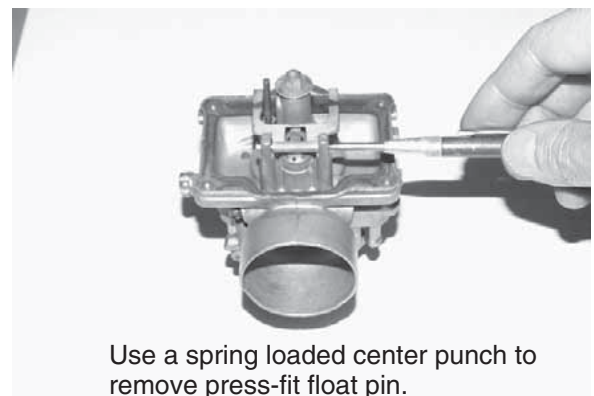

Use a spring loaded center punch to remove press-fit float pin.

**NOTE:** Set the center punch to the softest setting (if adjustable) to avoid damage to float pin tower.

### TROUBLESHOOTING

#### FUEL STARVATION/LEAN MIXTURE

**Symptoms:** Hard start or no start, bog, backfire, popping through intake / exhaust, hesitation, detonation, low power, spark plug erosion, engine runs hot, surging, high idle, idle speed erratic.

- No fuel in tank
- Restricted tank vent, or routed improperly
- Fuel lines or fuel valve restricted
- Fuel filter plugged
- Carburetor vent line(s) restricted
- Plugged or restricted inlet needle and seat screen or inlet passage
- Clogged jets or passages
- Float stuck, holding inlet needle closed or inlet needle stuck
- Float level too low
- Intake air leak (throttle shaft, intake ducts, airbox or air cleaner cover)
- Jet needle position incorrect
- Incorrect pilot screw adjustment

#### RICH MIXTURE

**Symptoms:** Fouls spark plugs, black, sooty exhaust smoke, rough idle, poor fuel economy, engine runs rough/misses, poor performance, bog, engine loads up, backfire.

- Air intake restricted (inspect intake duct)
- Air filter dirty/plugged
- Choke plunger sticking, incorrectly adjusted choke
- Choke cable binding or improperly routed
- Incorrect pilot air/fuel screw adjustment
- Faulty inlet needle and seat
- Faulty inlet needle seat O-Ring
- Float level too high
- Poor fuel quality (old fuel)
- Loose jets
- Worn jet needle/needle jet or other carburetor parts
- Dirty carburetor (air bleed passages or jets)
- Fouled spark plug

#### POOR IDLE

**Symptoms:** Idle too high.

- Idle adjusted improperly/idle mixture screw damaged
- Sticky throttle valve
- Throttle cable sticking, improperly adjusted, routed incorrectly
- Choke cable sticking, improperly adjusted, routed incorrectly

---

## **TROUBLESHOOTING**

### **IDLE TOO LOW**

- Choke cable incorrectly adjusted
- Idle speed set incorrectly
- Idle mixture screw misadjusted or damaged
- Belt dragging
- Ignition timing incorrect
- Worn jet needle/needle jet

### **ERRATIC IDLE**

- Choke cable bending or incorrectly adjusted
- Throttle cable incorrectly adjusted
- Air leaks, dirty carburetor passages (pilot circuit)
- Pilot mixture screw damaged or adjusted incorrectly
- Tight valves
- Ignition timing incorrect
- Belt dragging
- Dirty air cleaner
- Engine worn
- Spark plug fouled
- Idle speed set incorrectly (speed limiter)
- Worn jet needle/needle jet





# ***CHAPTER 4***

## ***BODY AND STEERING***

Torque Specifications and Special Tools .....	4.1
Frame Photos .....	4.2
Engine Mounting .....	4.3-4.4
Shocks and Springs .....	4.5
Suspension A-arms .....	4.6
Steering .....	4.7-4.8
Front Brake .....	4.9-4.10
Rear Brake and Axle .....	4.10-4.13
Fuel and Oil Tank .....	4.14
Front and Rear Cab .....	4.15
Handlebar .....	4.16-4.18
Muffler .....	4.18



**TORQUE SPECIFICATIONS**

Front A-Arm Attaching Bolt	26-30 ft. lbs. (36-40 Nm)
Handlebar Adjuster Block	84 in. lbs. (10 Nm)
Rear Shock Bolts	25 ft. lbs. (35 Nm)
Rear Wheel Hub Nut	78-81 ft. lbs. (108-112 Nm)
Front Shock Bolts	15 ft. lbs. (20 Nm)
Swing Arm Mounting Bolt	26-30 ft. lbs. (36-40 Nm)
Inner Tie Rod Bolts	33-40 ft. lbs. (45-55 Nm)
Outer Tie Rod Bolts	33-40 ft. lbs. (45-55 Nm)
Tie Rod Jam Nuts	12-14 ft. lbs (17-19 Nm)
Motor Mount Bolts-M8	22-25 ft. lbs (30-35 Nm)
Motor Mount Bolts-M10	33-40 ft. lbs (45-55 Nm)
Spindle Nuts	40-45 ft. lbs (58-62 Nm)
Steering Post Mount Nuts	103 in. lbs (11.6 Nm)
Steering Post Nut	62-65 ft. lbs (86-90 Nm)
Steering Nuts	62-65 ft. lbs (86-90 Nm)
Sprocket Bolts	18 ft. lbs (25 Nm)
Chain Tensioner Bolt	84 in. lbs (10 Nm)
Bearing Carrier Mounting Bolts	43 ft. lbs (60 Nm)
Rear Cover Mounting Bolts	84 in. lbs (10 Nm)
Fuel Tank Mounting Bolts	103 in. lbs (12 Nm)
Oil Tank Mounting Bolts	103 in. lbs (12 Nm)
Front Bumper Mounting Bolts	103 in. lbs (12 Nm)
Cab Mounting Bolts	103 in. lbs (12 Nm)
Muffler Mounting Bolts	25 ft. lbs (34 Nm)

**NOTE:** Refer to exploded views throughout this chapter for identification and location of components.

**SPECIAL TOOLS**

<u>Description</u>	<u>Part No.</u>
Shock Spanner Wrench	2870872
Shock Spring Compressor Tool	2870623

**FRAME PHOTOS**

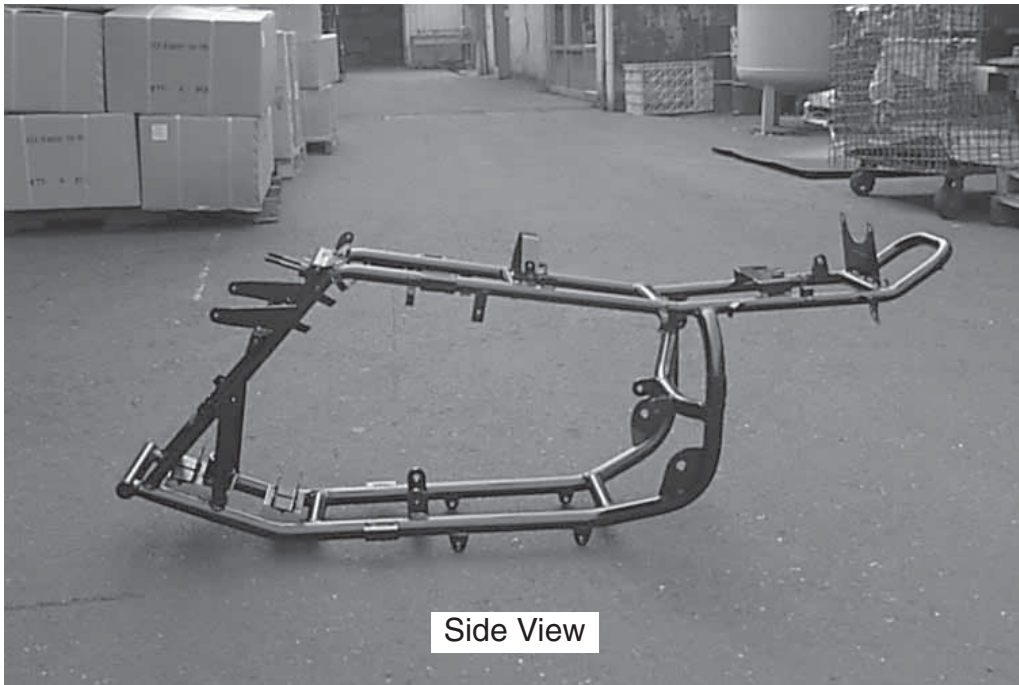

Side View

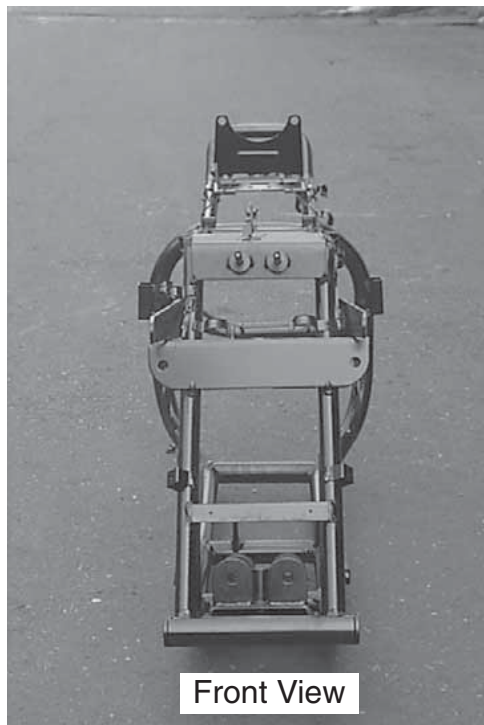

Front View



Rear View

**ENGINE MOUNTING**

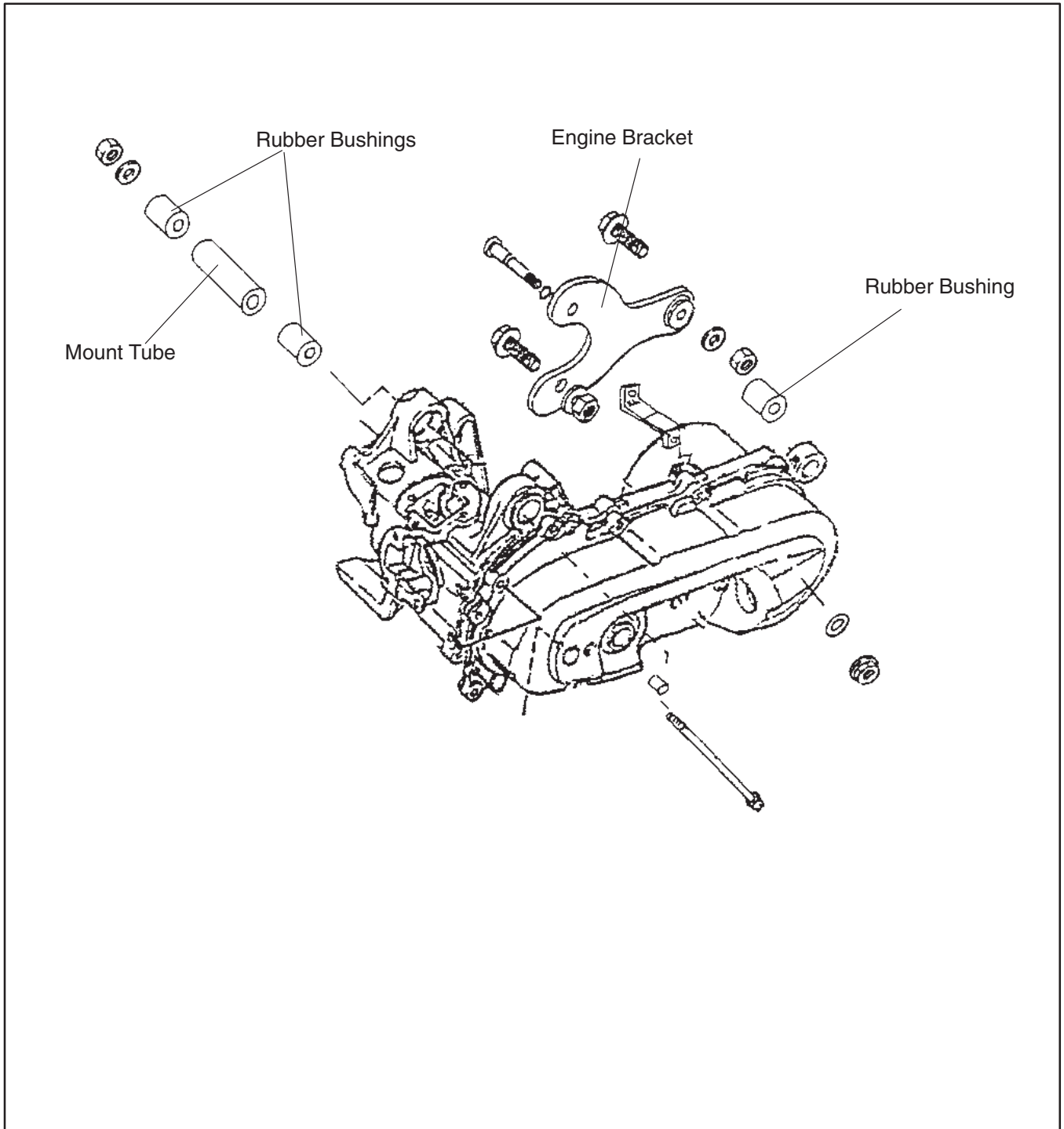

### ENGINE MOUNTING

1. Install rubber dampers under footrest and install footrest on frame body.
2. Tighten footrest bolts.
3. There are three (3) engine mounting positions on the frame. Check each bushing of the engine brackets for damage or wear before mounting the engine to the frame body.
4. Insert the engine into the frame body. Mount to the brackets including the fix tube, spacer tube, and engine holder seat.

**Motor Mount Bolt Torque:**  
M10= 33-40 ft.lbs. (45-55 Nm)  
M8= 22-25 ft.lbs. (30-35 Nm)

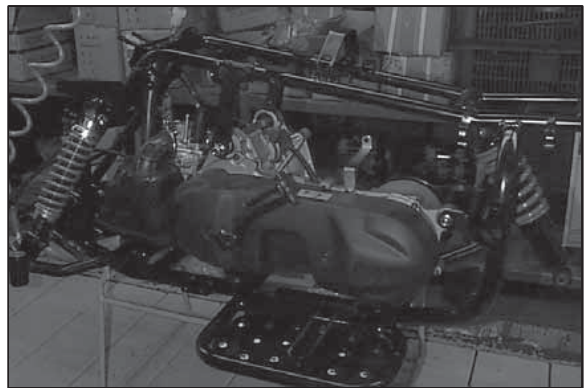
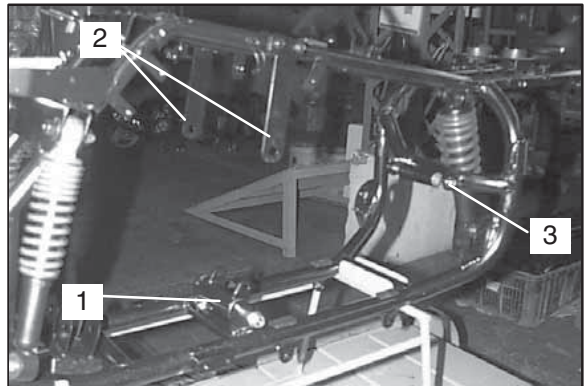
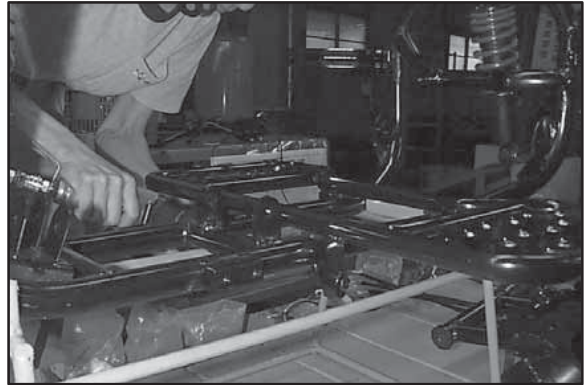

## SHOCKS AND SPRINGS

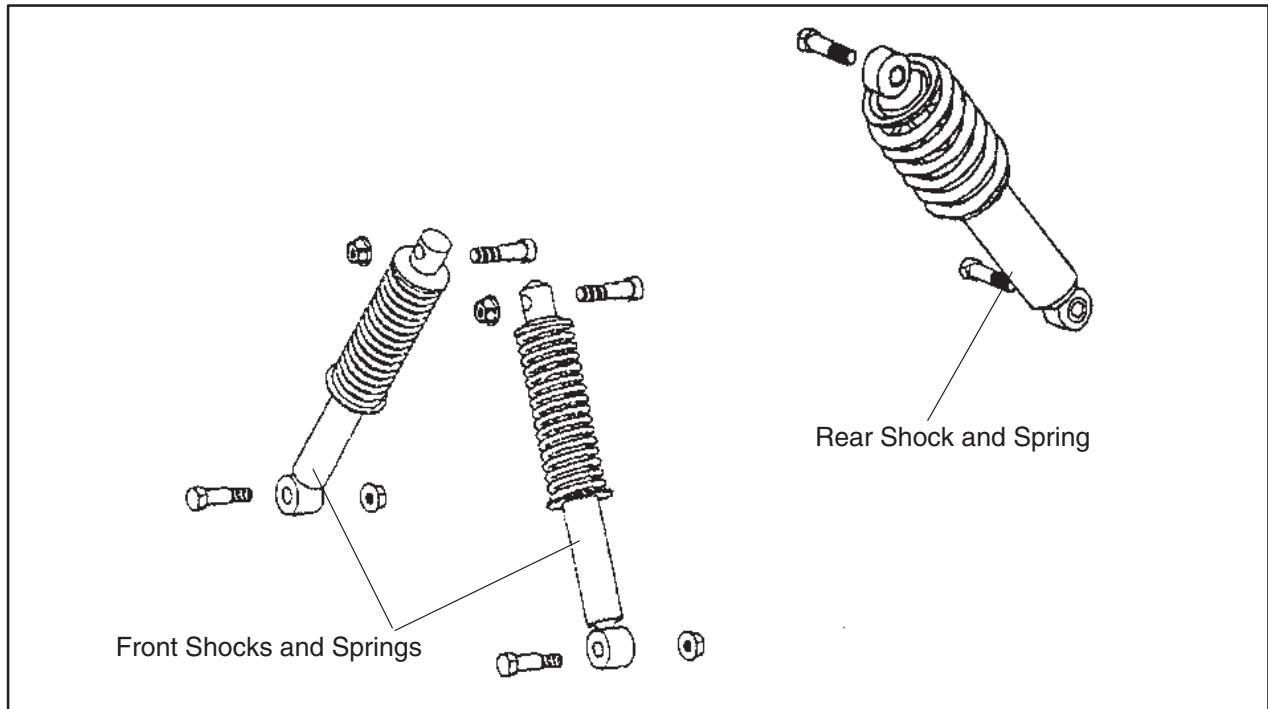

1. The front shocks and springs are mounted on the frame and A-arm. The front springs on the Sportsman 90 can be adjusted for more or less spring preload depending on rider preference.

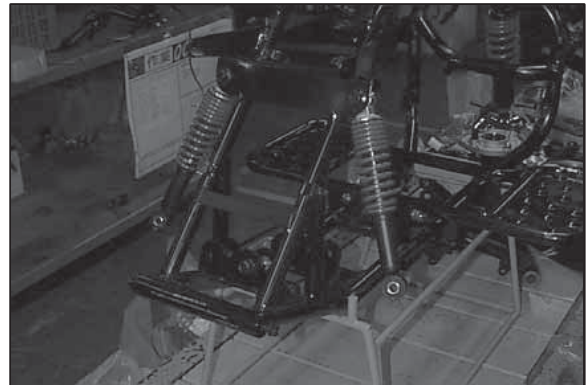

2. The rear shock and spring is mounted to the frame and swing arm. The rear spring can be adjusted for more or less spring preload depending on rider preference.

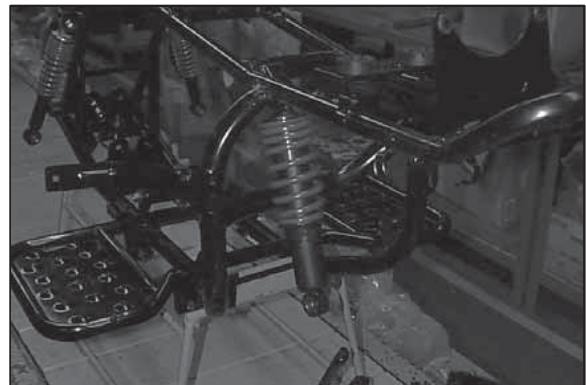

**SUSPENSION A-ARMS**

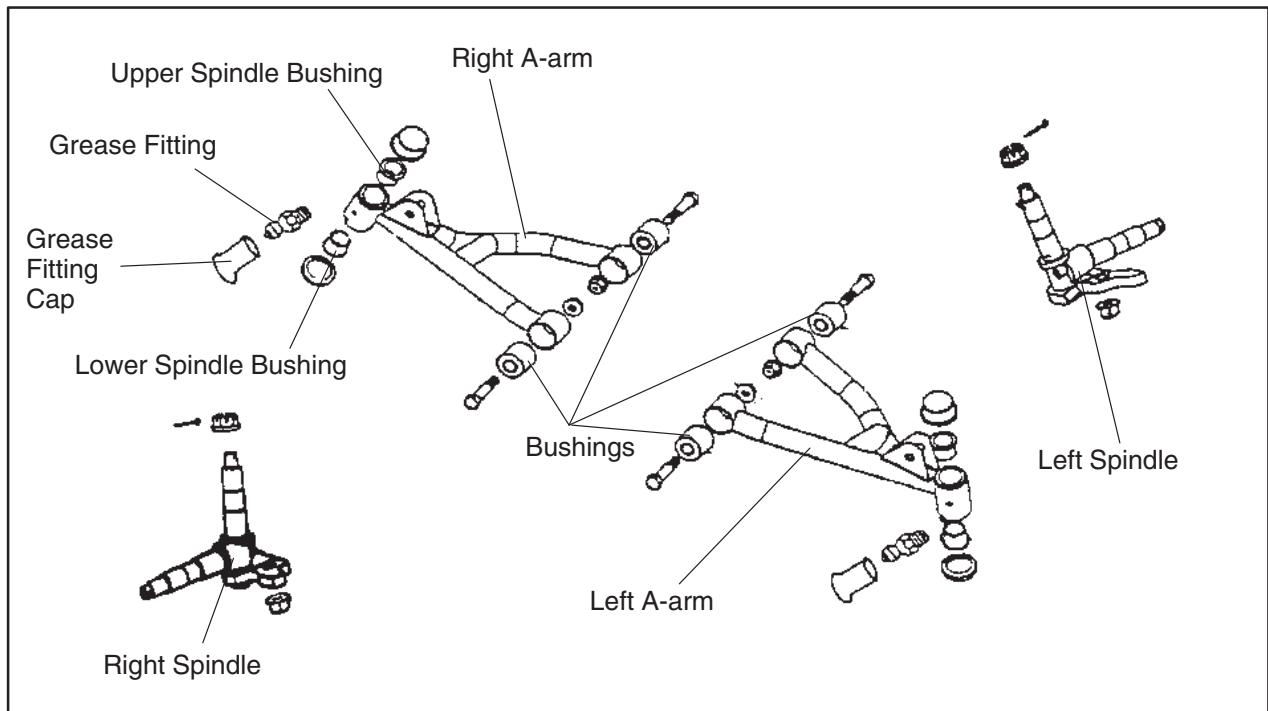

1. Mount the A-arms to the frame body. The A-arm marked "R" is for right side, and A-arm marked "L" is for left side. Torque the bolts to specification. Mount the shock in the A-arm and torque bolt to specification.

**A-arm Mounting Bolt Torque:**  
**26-30 ft.lbs. (36-40 Nm)**  
**Shock Mounting Bolt Torque:**  
**15 ft.lbs. (20 Nm)**

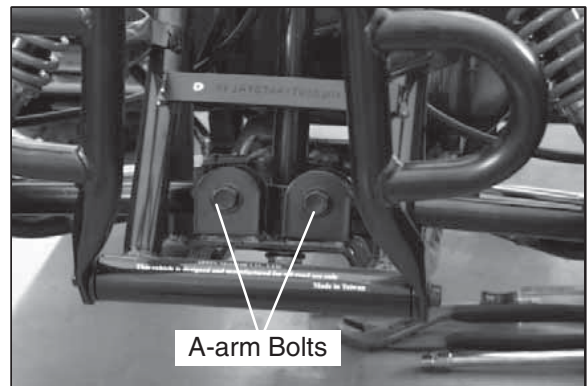

2. Grease spindles and mount the spindles on the A-arms. The spindle marked "R" is for right side, and "L" for left side. Torque the spindle nut to specification. Insert cotter key.

**Spindle Nut Torque:**  
**40-45 ft.lbs (58-62 Nm)**





**STEERING**

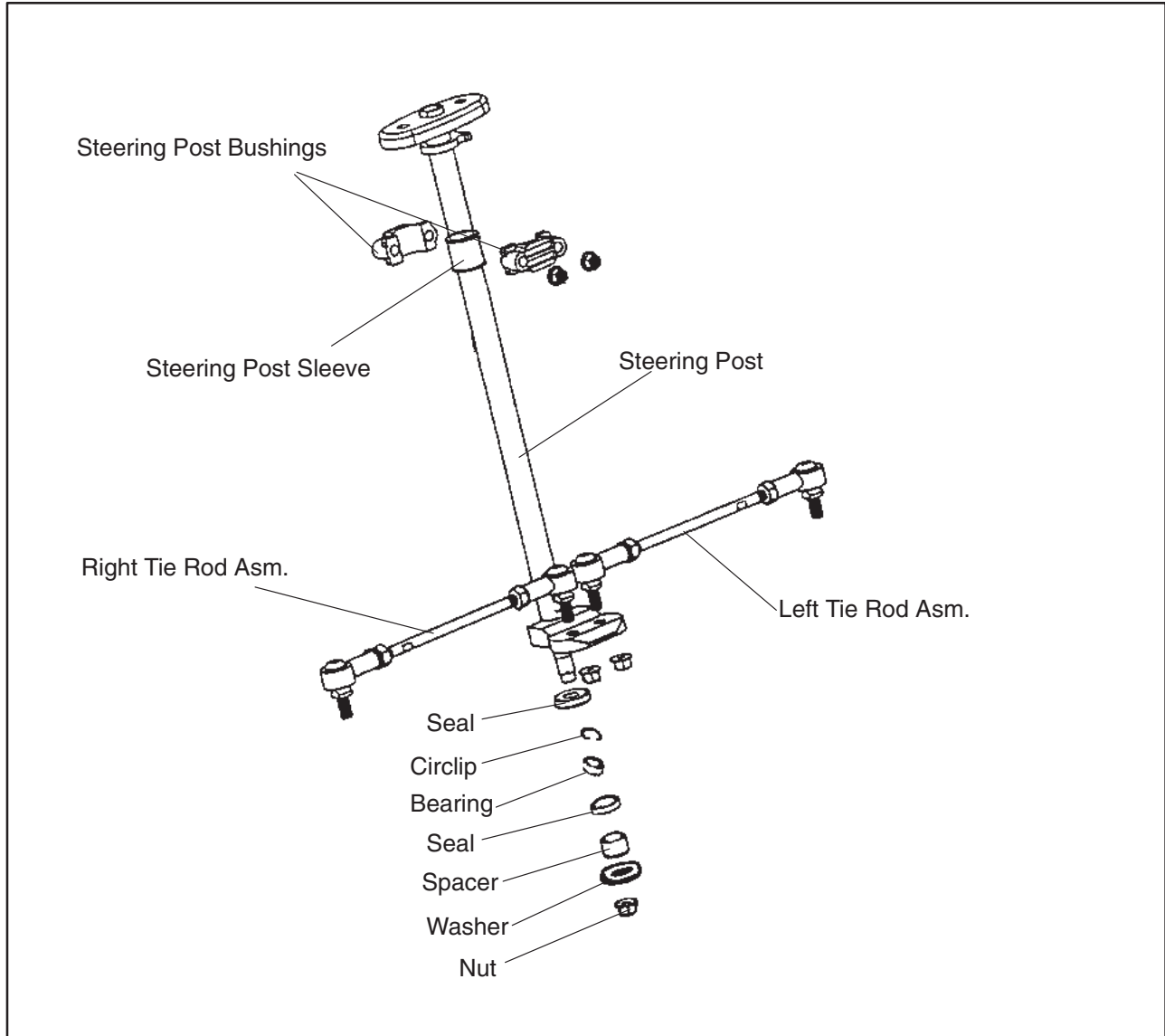

1. Grease the steering post sleeve and insert in place. Mount the steering post clamps on post. Install the steering post and tighten the steering post mount nuts to specification.

**Steering Post Mount Nut Torque:  
103 in.lbs. (11.6 Nm)**

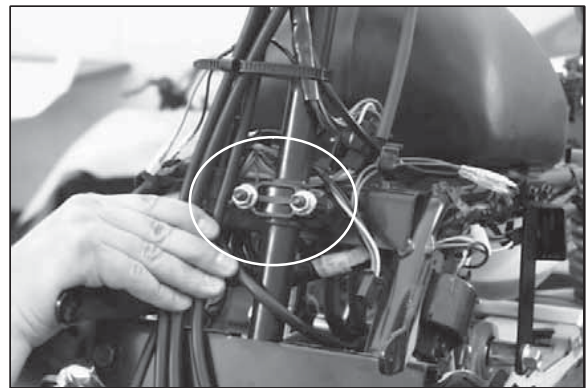

**STEERING, CONT.**

2. Install oil seals, bearing, steering nut and associated hardware on the bottom of the steering post. Torque nut to specification.

**Steering Post Nut Torque:  
62-65 ft.lbs. (86-90 Nm)**

**NOTE:** Turn the steering post after mounting to make sure the post turns freely in both directions without binding.

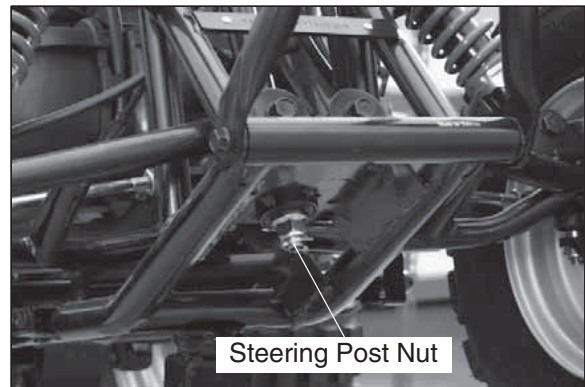

3. Mount the tie rod to the steering post and to the spindle. Mount the tie rod so that the end with the flats is toward the spindle.

**Steering Nut Torque:  
62-65 ft.lbs. (86-90 Nm)**

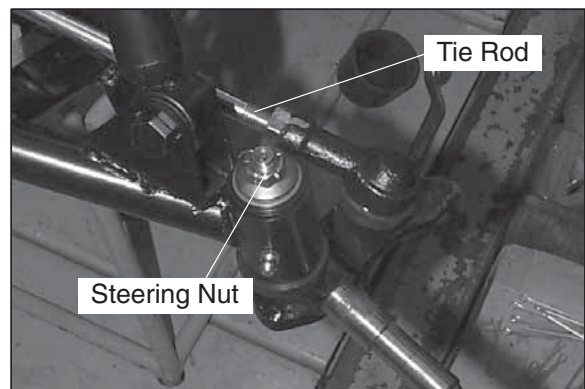

4. Tighten inner and outer tie rod bolts to specification.

**Inner Tie Rod Bolt Torque:  
33-40 ft.lbs (45-55 Nm)  
Outer Tie Rod Bolt Torque:  
33-40 ft.lbs (45-55 Nm)**

**Tie Rod Jam Nut Torque:  
12-14 ft.lbs (17-19 Nm)**

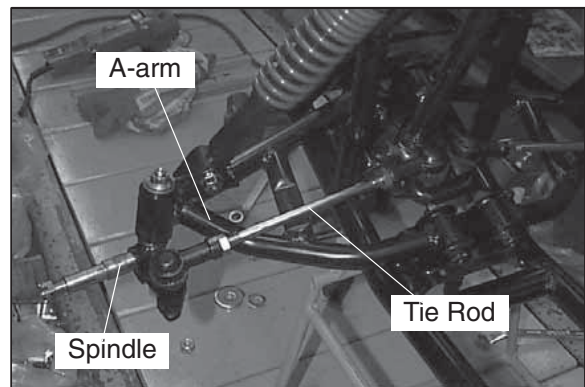

**FRONT BRAKE**

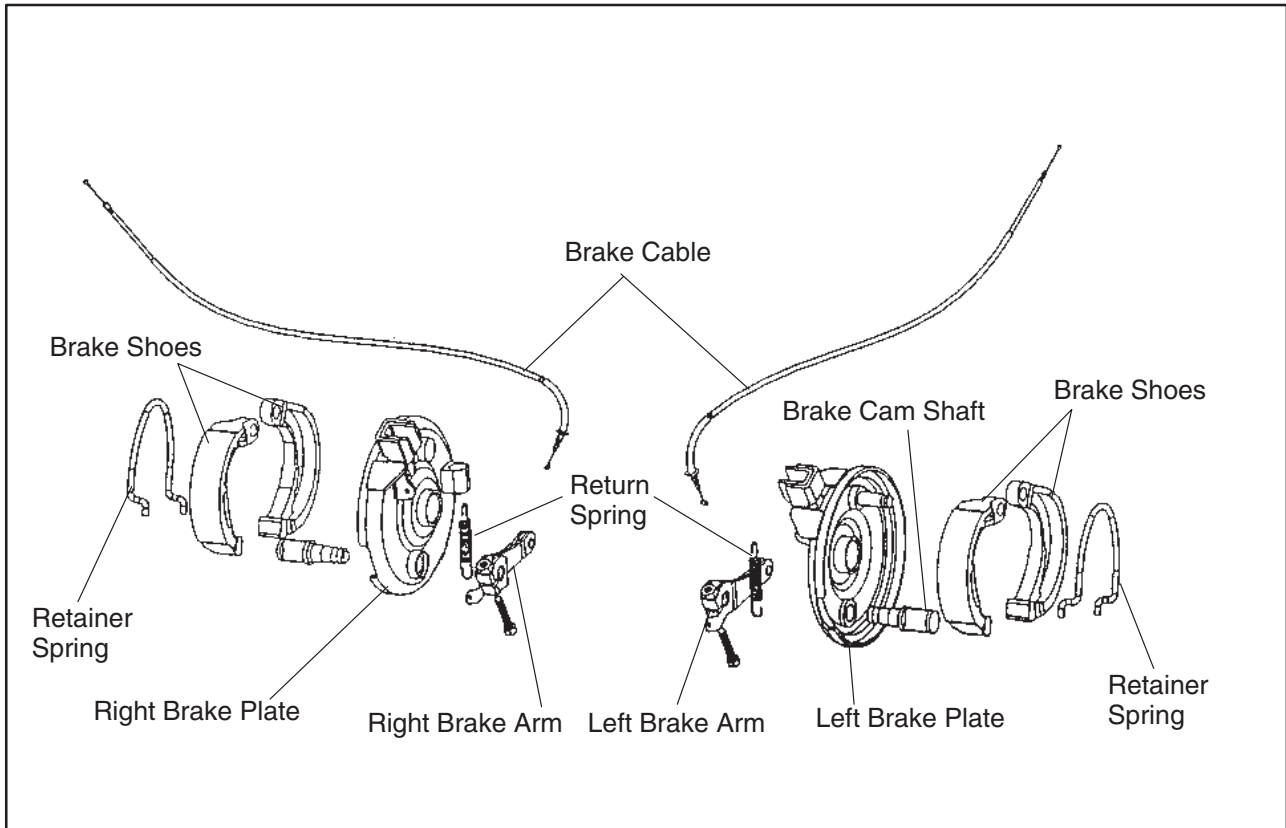

1. Front brake backing plate assembly components.

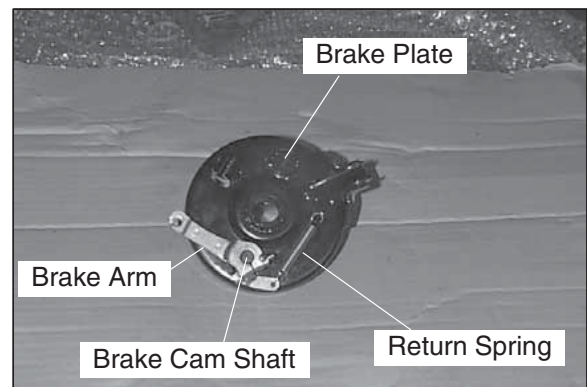

2. Front brake shoe and brake drum. There are oil seals and bearings in the front brake drums. Upon disassembly, inspect the bearings and seals for damage. Replace bearings and seals if necessary.

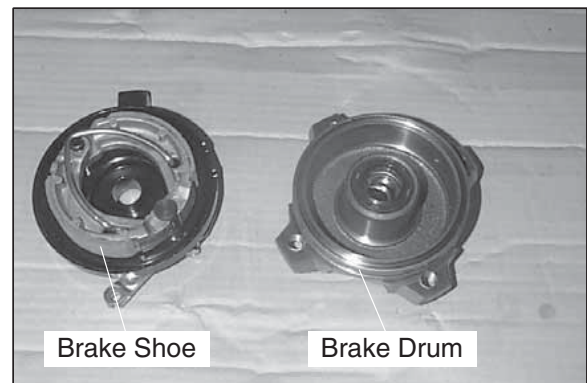

**FRONT BRAKE, CONT.**

3. Mount the front brake assembly on the spindle.
4. Mount the brake drum on the backing plate assembly and tighten the spindle nut to specification.

**Spindle Nut Torque:  
42-45 ft.lbs. (58-62 Nm)**

5. Connect the brake cable with brake arm.
6. Install the rubber cap.

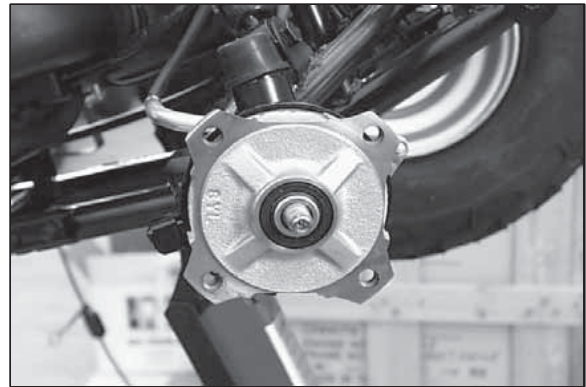
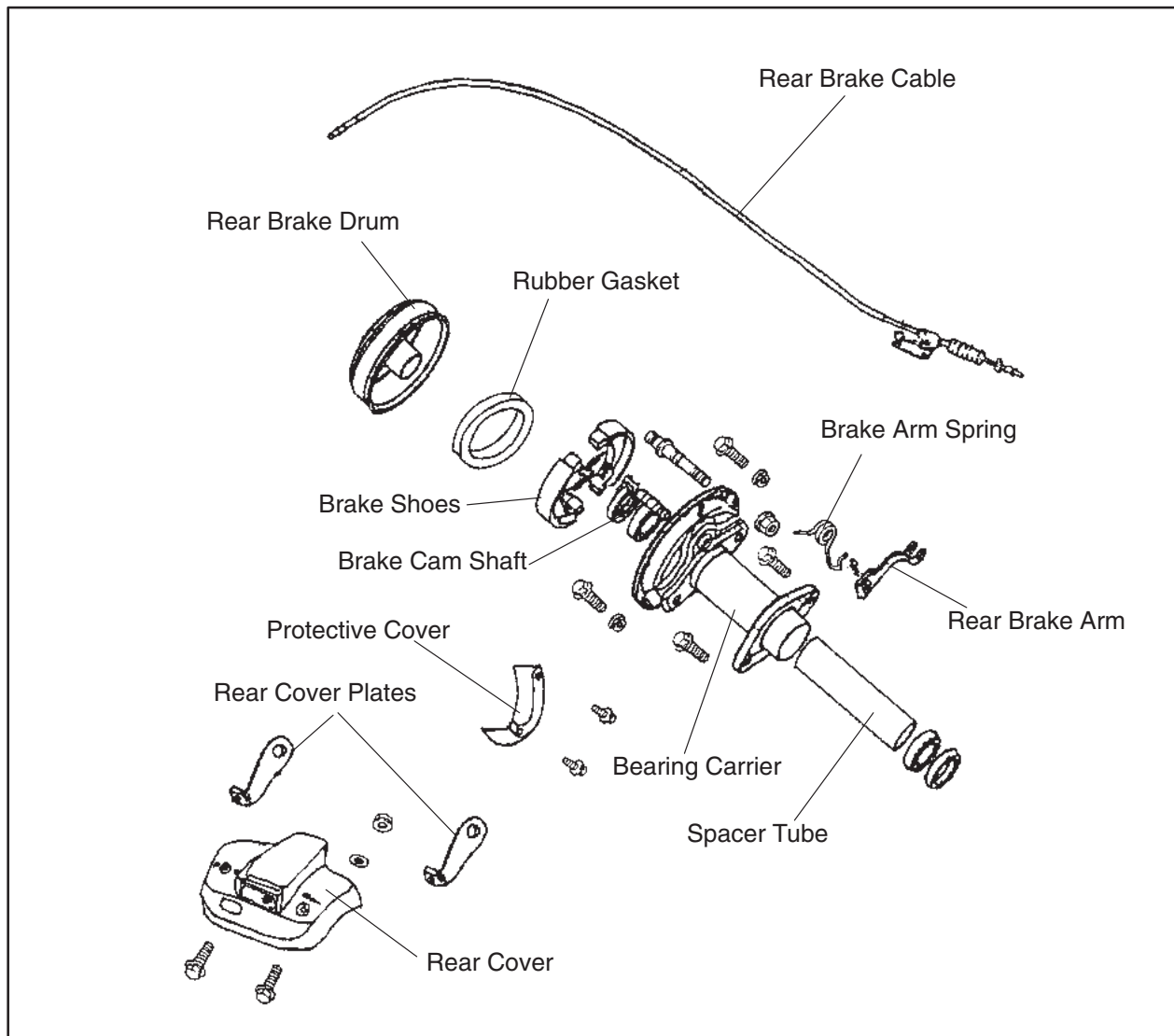
**REAR BRAKE AND AXLE**

**REAR BRAKE AND AXLE, CONT.**

1. Apply grease to the swing arm spacer tube. The swing arm assembly must be mounted first.

**NOTE:** The swing arm assembly includes chain protector.

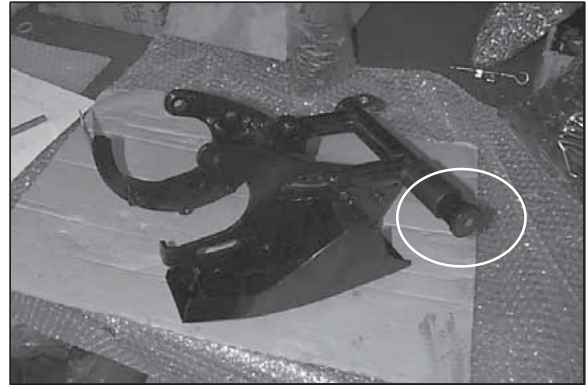

2. Install the swing arm to the frame and tighten the mounting bolt to specification. Install rear shock and spring. Tighten shock mounting bolts to specification.

**Swing Arm Mounting Bolt Torque:**  
26-30 ft.lbs. (36-40 Nm)  
**Rear Shock Mounting Bolt Torque:**  
25 ft.lbs. (35 Nm)

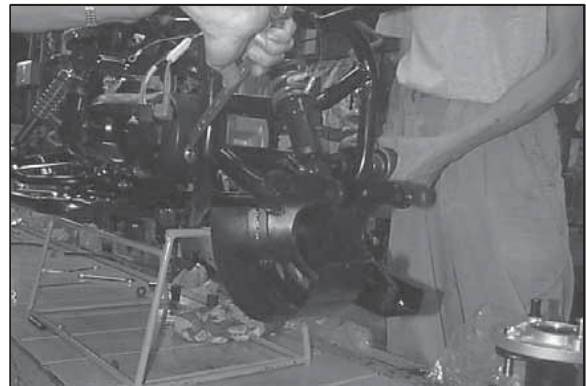

3. Inspect the protective rubber gasket on the rear brake drum for damage. Replace if needed. Mount the rear brake plate, shoes, and springs on the bearing carrier. Install the brake drum.

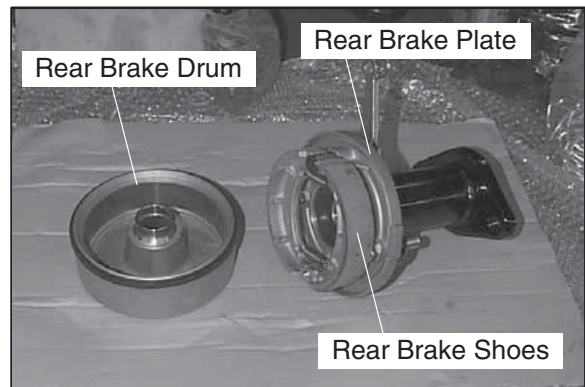

4. Install the rear axle bearing carrier and rear brake assembly on swing arm.

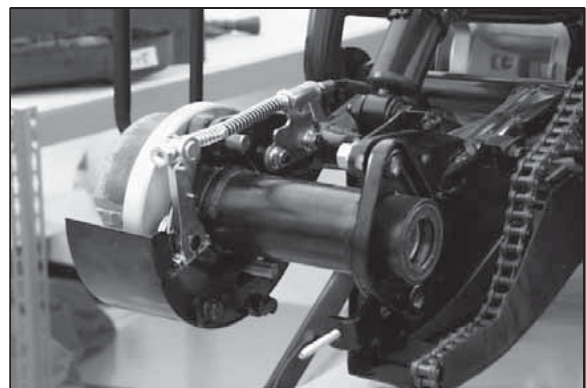

**REAR BRAKE AND AXLE, CONT.**

5. Install rear axle. Tighten the bolts until snug. The rear axle bearing carrier needs to be adjusted for chain tension. Do not tighten to specified torque at this time.

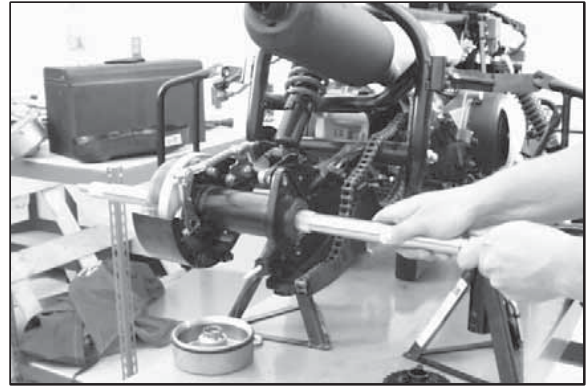

6. Install the drive sprocket on the rear wheel axle.

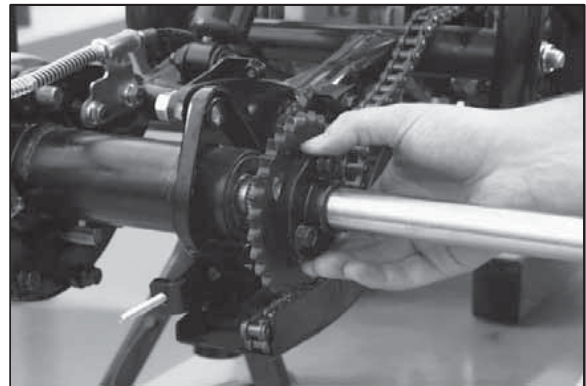

7. Install the right and left spacer tube on the rear wheel axle.

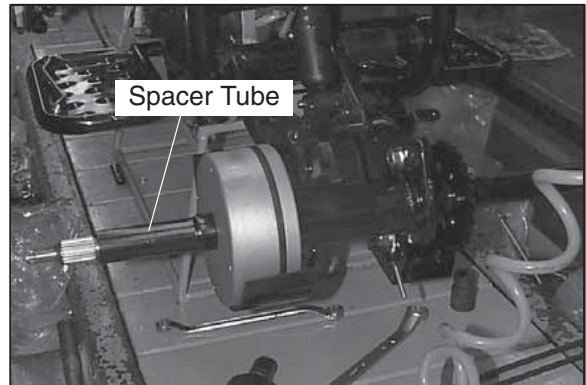

8. Install the wheel hub and tighten axle nut to specification.

**Axle Nut Torque:  
78-81 ft.lbs. (108-112 Nm)**

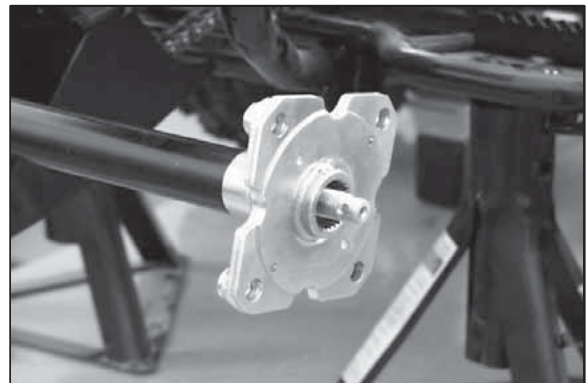

**REAR BRAKE AND AXLE, CONT.**

9. Install rear brake cable on brake arm.
10. Install chain on drive sprocket and tighten sprocket bolts to specification.

**Sprocket Bolt Torque:  
18 ft.lbs. (25 Nm)**

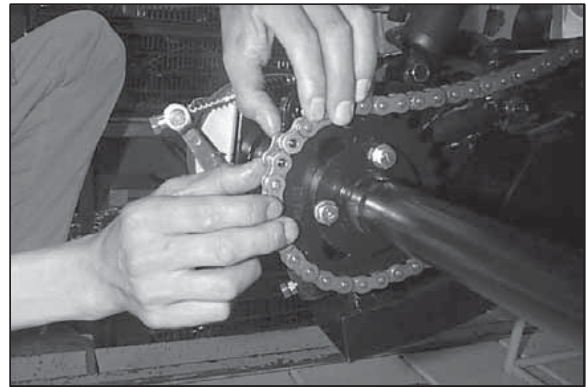

11. Set the chain tension to specification by loosening the lock nuts on the chain adjuster. Turn the adjuster until the chain tension is set. Tighten the adjuster nuts.

**Chain Tension Specification:  
.40-.80" (10-20 mm) slack  
Chain Tensioner Nut Torque:  
84 in.lbs. (10 Nm)**

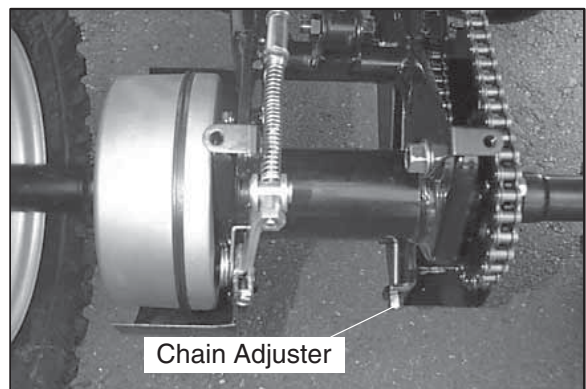

12. Tighten all bearing carrier bolts to specification.

**Bearing Carrier Bolt Torque:  
43 ft.lbs. (60 Nm)**

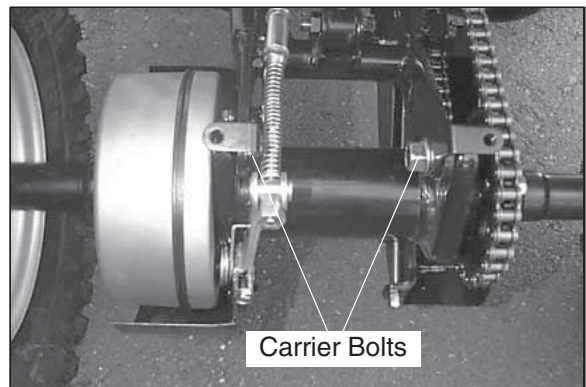

13. Install the rear cover. Torque bolts to specification.

**Rear Cover Bolt Torque:  
84 in.lbs. (10Nm)**



Carrier Bolts

## **FUEL AND OIL TANK**

1. Install fuel tank in the frame and tighten bolts to specification. Make sure the fuel tank pads are in place and in good condition.

**Fuel Tank Mounting Bolt Torque:  
103 in.lbs. (12 Nm)**



2. Install the oil tank to the frame and tighten bolts to specification. Always fill the oil reservoir before riding.

**Oil Tank Mounting Bolt Torque:  
103 in.lbs. (12 Nm)**

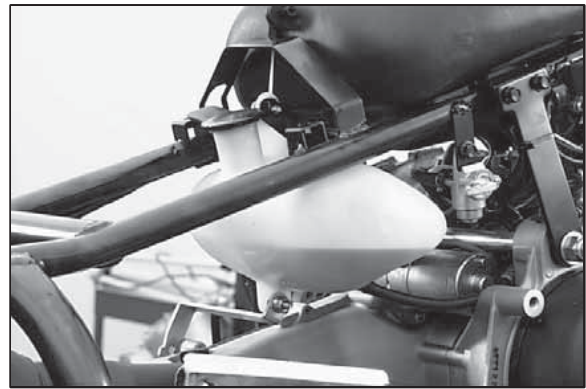

3. The fuel petcock has “ON”, “OFF”, and “RES”. Make note of these positions on the petcock. Always turn fuel off when transporting an ATV.

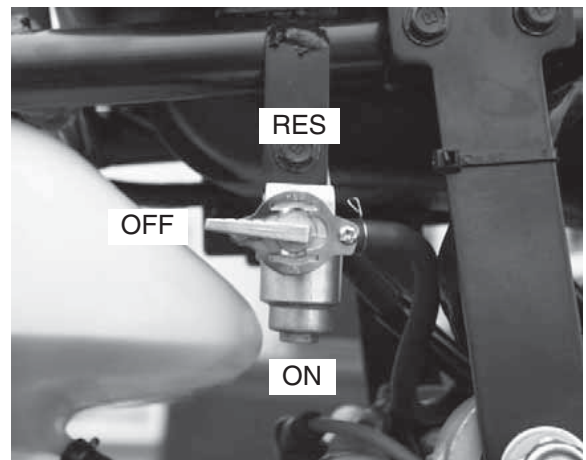



**FRONT AND REAR CAB**

1. Install the bumper to the frame and tighten mounting bolts to specification.

**Front Bumper Mounting  
Bolt Torque:  
103 in.lbs. (12 Nm)**



2. There are three (3) mounting positions for the front and rear cab to the frame. The front cab is mounted on positions 1 and 2. The rear cab is mounted on position 3.

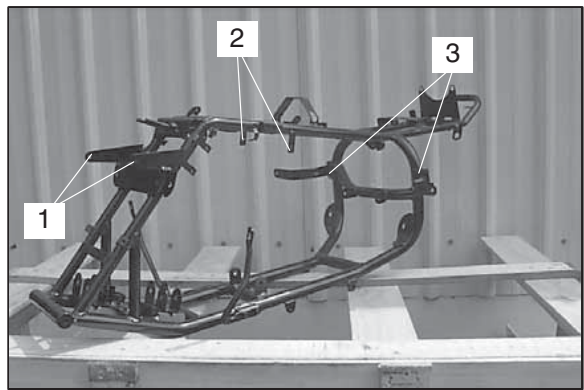

3. Install the front and rear cab to the frame and tighten the mounting bolts to specification.

**Cab Mounting Bolt Torque:  
103 in.lbs. (12 Nm)**

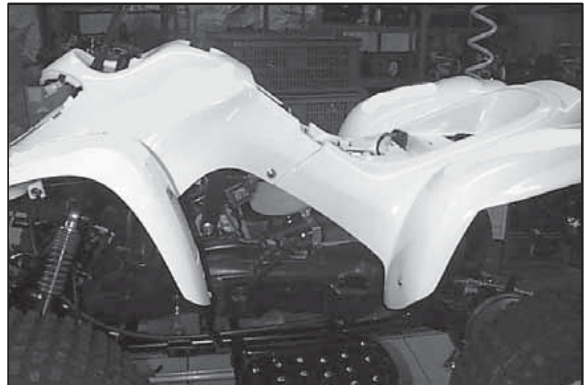

4. The front cab mounts to the front bracket of the frame.

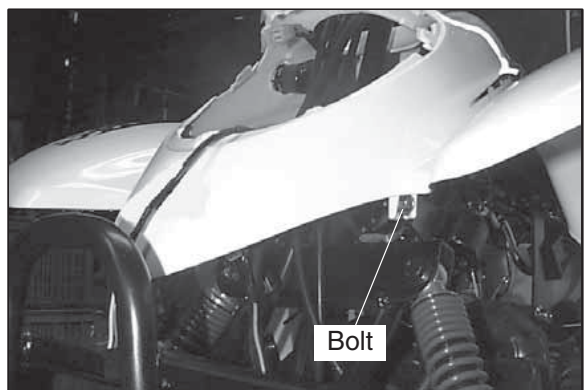

# HANDLEBAR

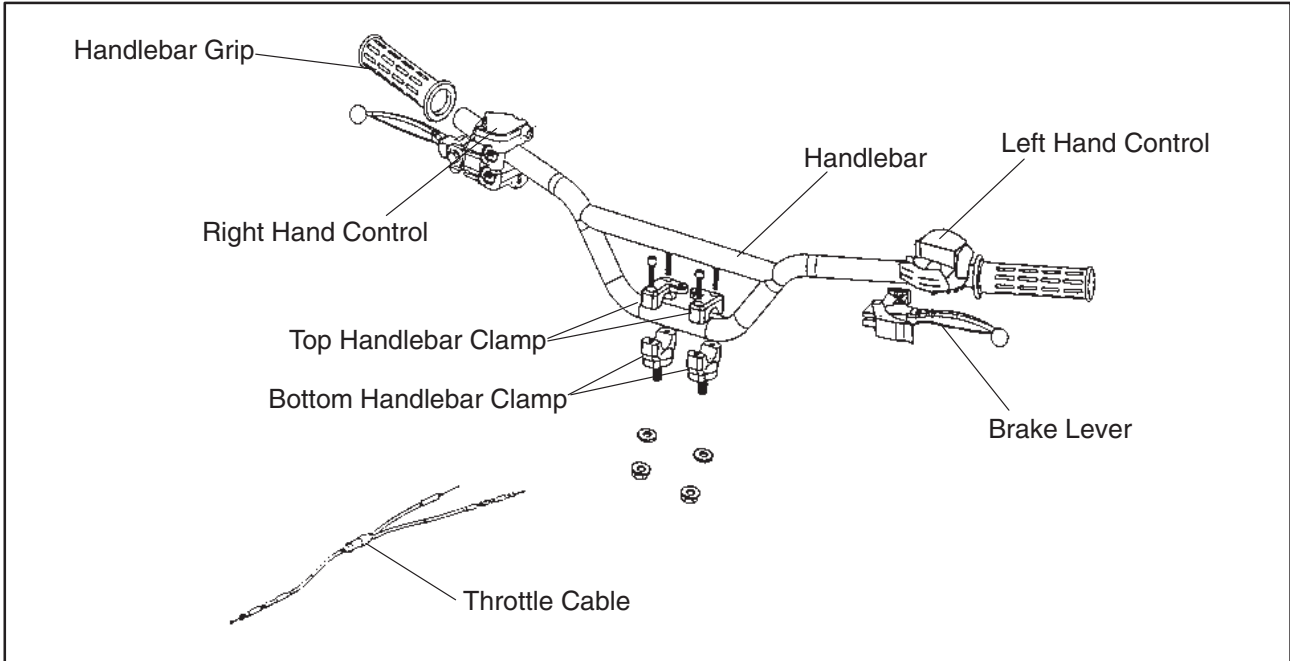

1. The handlebar assembly includes the right and left side brake levers and the left side control switch.

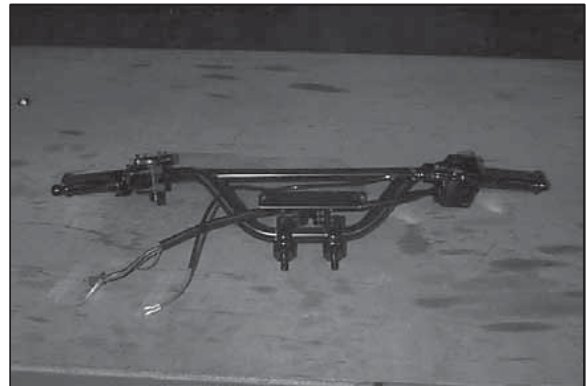

2. The left side control switch includes the engine stop switch and start switch. There is a parking brake on the left brake lever. It is designed for safety assurance. Always engage the parking brake when the vehicle is stopped and the engine is shut off.

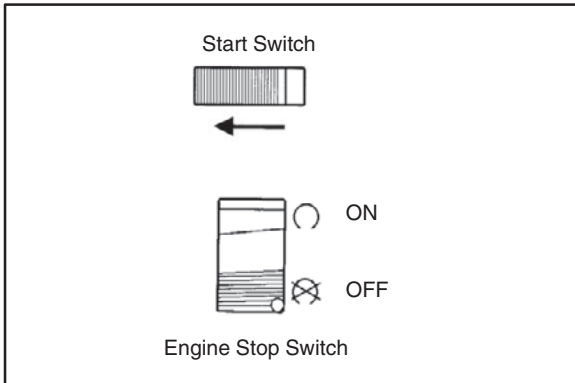

**HANDLEBAR, CONT.**

3. Mount the handlebar on the steering post and tighten the clamp bolts to specification.

**Handlebar Mounting Clamp  
Bolt Torque:  
84 in.lbs. (10 Nm)**

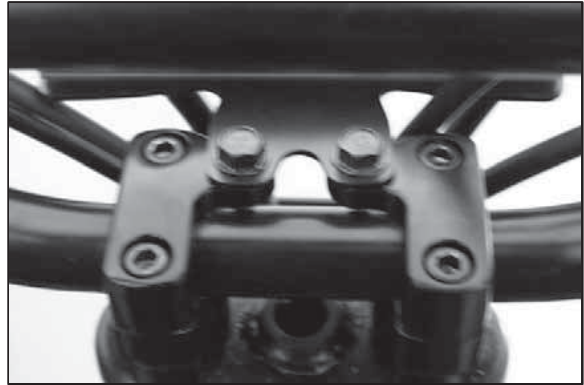

4. Install the right side and left side front brake cables as shown.

**Front Brake Lever Free Play:  
.40-.80" (10-20 mm)**

**Front Brake Lever Travel:  
50 cc= 1 1/8" (28 mm)  
90 cc = 1 3/4" (45 mm)**

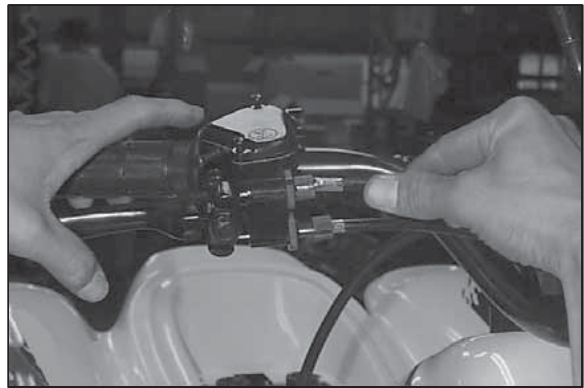

5. Install the rear brake cable.

**Rear Brake Lever Free Play:  
.40-.80" (10-20 mm)**

**Rear Brake Lever Travel:  
50 cc= 1 1/8" (28 mm)  
90 cc = 2 1/2" (65 mm)**

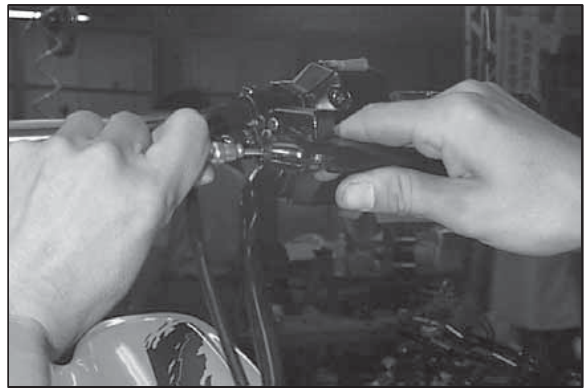

6. Open the throttle ETC switch box and lightly grease the throttle cable (A). Install the throttle cable.

**Electronic Throttle Control (ETC) Switch  
(Cast Aluminum Throttle Housing)**

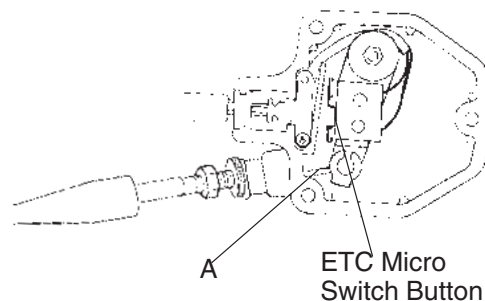

**HANDLEBAR, CONT.**

7. Install the plate and handlebar cover.

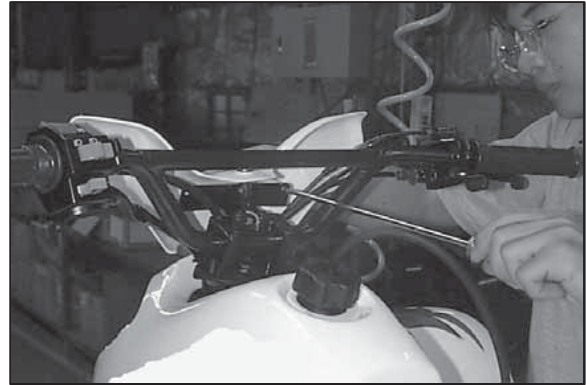

**MUFFLER**

1. Connect the muffler to the cylinder and install. Inspect sealing gaskets upon installation. Replace if necessary.
2. Connect the muffler to the mounting bracket on the frame. Tighten bolt to specification.

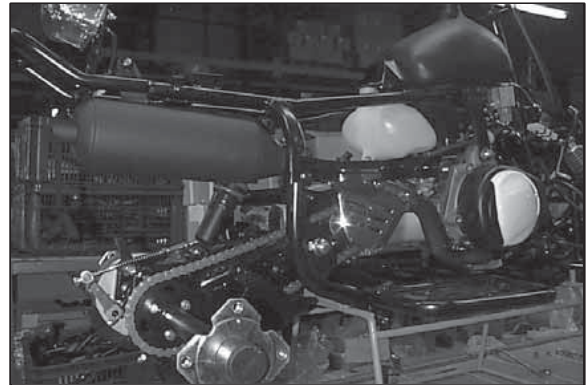

**Muffler Mounting Bolt Torque:  
25 ft.lbs. (34 Nm)**

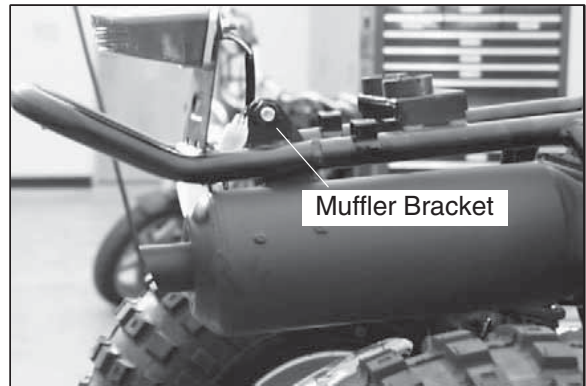

# ***CHAPTER 5***

## ***ELECTRICAL***

Special Tools .....	5.1
Electrical Service Notes .....	5.1
Brakelight Lamp Replacement .....	5.1
Battery Service / Terminals and Bolts .....	5.2
Battery Inspection / Removal .....	5.3
Battery Installation / Testing .....	5.3
Open Circuit Voltage Test .....	5.3
Specific Gravity Test / Load Test .....	5.4
Off Season Storage / Charging Procedure .....	5.5
Electronic Parts / Current Draw-Key Off .....	5.6
Charging System Testing .....	5.7
Ignition System .....	5.8-5.9
Cranking Output Test .....	5.10
CDI Output Test .....	5.10
Charging System Testing .....	5.11-5.12
Alternator Output Test (AC Amp) .....	5.13
Starter System Troubleshooting / Voltage Drop Test ..	5.14
Starter System .....	5.15
Starter Motor Disassembly .....	5.16-5.17
Brush Inspection / Replacement .....	5.17-5.18
Armature Testing .....	5.18
Starter Assembly .....	5.19
Electronic Throttle Control (ETC) .....	5.20
Ignition System Troubleshooting .....	5.21
Wiring Diagram - Scrambler 50 .....	5.22
Wiring Diagram - Scrambler 90 / Sportsman 90 .....	5.23



## SPECIAL TOOLS

Fluke 73 Multitester or Tektronix DMM 155 . . .	PN 2870659
Strobe Timing Light . . . . .	PN 2870630
Hydrometer . . . . .	PN 2870836
Tachometer . . . . .	PN 8712100 or PN 8712500

## ELECTRICAL SERVICE NOTES

Keep the following notes in mind when diagnosing an electrical problem.

- Refer to wiring diagram for stator and electrical component resistance specifications.
- When measuring resistance of a component that has a low resistance value (under 10 Ohms), remember to subtract meter lead resistance from the reading. Connect the leads together and record the resistance. The resistance of the component is equal to tested value minus the lead resistance.
- Become familiar with the operation of your meter. Be sure leads are in the proper jack for the test being performed (i.e. 10A jack for current readings). Refer to the Owner's manual included with your meter for more information.
- Voltage, amperage, and resistance values included in this manual are obtained with a Fluke™ 73 Digital Multimeter or a Tektronix DMM155. Both of these meters are acceptable for use when diagnosing electrical problems. Readings obtained with other meters may differ.
- Pay attention to the prefix on the multimeter reading (K, M, etc.) and the position of the decimal point.
- For resistance readings, isolate the component to be tested. Disconnect it from the wiring harness or power supply.

## BRAKELIGHT LAMP REPLACEMENT

If the brakelight does not work the lamp may need to be replaced.

1. From the rear of the taillight remove two screws holding lens cover in place and remove lens cover.
2. Remove lamp and replace it with recommended lamp. Apply Nyogel™ grease PN 2871329.
3. Reinstall the lens cover removed in step 1.
4. Test the taillight/brakelight to see that it's working.

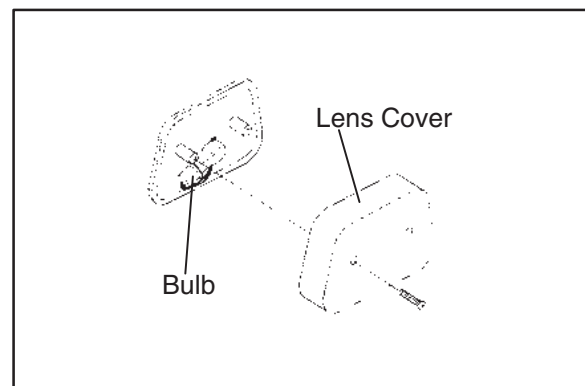

### INITIAL BATTERY SERVICE

#### **WARNING**

Battery electrolyte is poisonous. It contains sulfuric acid. Serious burns can result from contact with skin, eyes or clothing. Antidote:

**External:** Flush with water.

**Internal:** Drink large quantities of water or milk. Follow with milk of magnesia, beaten egg, or vegetable oil. Call physician immediately.

**Eyes:** Flush with water for 15 minutes and get prompt medical attention.

Batteries produce explosive gases. Keep sparks, flame, cigarettes, etc. away. Ventilate when charging or using in an enclosed space. Always shield eyes when working near batteries. **KEEP OUT OF REACH OF CHILDREN.**

**WARNING:** The gases given off by a battery are explosive. Any spark or open flame near a battery can cause an explosion which will spray battery acid on anyone close to it. If battery acid gets on anyone, wash the affected area with large quantities of cool water and seek immediate medical attention.

To ensure maximum service life and performance from a new battery, perform the following steps. **NOTE:** Do not service the battery unless it will be put into regular service within 30 days. After initial service, add only distilled water to the battery. Never add electrolyte after a battery has been in service.

**NOTE: New Battery:** Battery must be fully charged before use or battery life will be significantly reduced 10-30% of battery's full potential.

1. Remove vent plug from vent fitting.
2. Fill battery with electrolyte to upper level marks on case.
3. Set battery aside and allow it to cool and stabilize for 30 minutes.
4. Add electrolyte to bring level back to upper level mark on case. **NOTE:** This is the last time that electrolyte should be added. If the level becomes low after this point, add only distilled water.
5. Charge battery at 1/10 of its amp/hour rating. Examples: 1/10 of 9 amp battery = .9 amp; 1/10 of 14 amp battery = 1.4 amp; 1/10 of 18 amp battery = 1.8 amp (recommended charging rates).
6. Check specific gravity of each cell with a hydrometer to assure each has a reading of 1.270 or higher.

### **BATTERY TERMINALS/TERMINAL BOLTS**

Use Polaris corrosion resistant Nyogel™ grease (PN 2871329) on battery bolts. See Battery Installation on page 5.3.



## BATTERY INSPECTION/REMOVAL

The battery is located under the seat.

Inspect the battery fluid level. When the battery fluid nears the lower level, the battery should be removed and distilled water should be added to the upper level line. To remove the battery:

1. Disconnect holder strap.
2. Disconnect battery negative (-) (black) cable first, followed by the positive (+) (red) cable.

### CAUTION

Whenever removing or reinstalling the battery, disconnect the negative (black) cable first and reinstall the negative cable last!

3. Remove the battery.
4. Remove the filler caps and add *distilled water only* as needed to bring each cell to the proper level. Do not overfill the battery.

 To refill use only distilled water. Tap water contains minerals which are harmful to a battery.

 Do not allow cleaning solution or tap water to enter the battery. It will shorten the life of the battery.

5. Reinstall the battery caps.

## BATTERY INSTALLATION

1. Clean battery cables and terminals with a stiff wire brush. Corrosion can be removed using a solution of one cup water and one tablespoon baking soda. Rinse with clean water and dry thoroughly.
2. Reinstall battery, attaching positive (+) (red) cable first and then the negative (-) (black) cable. Coat terminals and bolt threads with Polaris Nyogel™ grease PN 2871329.
3. Route cables so they are tucked away in front and behind battery.
4. Reinstall battery cover and holder strap.

## BATTERY TESTING

Whenever a service complaint is related to either the starting or charging systems, the battery should be checked first.

Following are three tests which can easily be made on a battery to determine its condition: OCV Test, Specific Gravity Test and Load Test.

### OCV - OPEN CIRCUIT VOLTAGE TEST

Battery voltage should be checked with a digital multimeter. Readings of 12.6 or less require further battery testing and charging. See charts and Load Test on page 5.4.

**NOTE:** Lead-acid batteries should be kept at or near a full charge as possible. Electrolyte level should be kept between the low and full marks. If the battery is stored or used in a partially charged condition, or with low electrolyte levels, hard crystal sulfation will form on the plates, reducing the efficiency and service life of the battery.

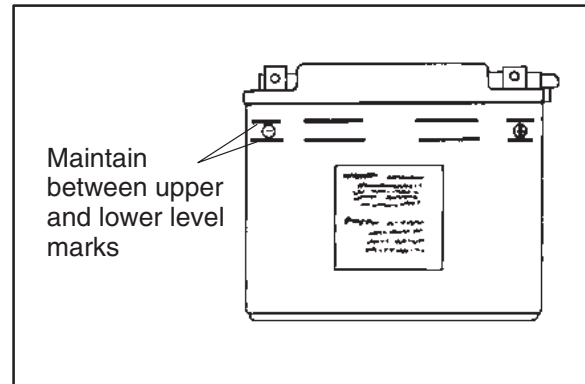

**SPECIFIC GRAVITY TEST**

A tool such as a Battery Hydrometer (PN 2870836) can be used to measure electrolyte strength or specific gravity. As the battery goes through the charge/discharge cycle, the electrolyte goes from a heavy (more acidic) state at full charge to a light (more water) state when discharged. The hydrometer can measure state of charge and differences between cells in a multi-cell battery. Readings of 1.270 or greater should be observed in a fully charged battery. Differences of more than .025 between the lowest and highest cell readings indicate a need to replace the battery.

OPEN CIRCUIT VOLTAGE		
State of charge	Conventional Lead-acid	YuMicron™ Type
100% Charged	12.60V	12.70V
75% Charged	12.40V	12.50V
50% Charged	12.10V	12.20V
25% Charged	11.90V	12.0V
0% Charged	less than 11.80V	less than 11.9V

SPECIFIC GRAVITY		
State of charge*	Conventional lead-acid	YuMicron™ Type
100% Charged	1.265	1.275
75% Charged	1.210	1.225
50% Charged	1.160	1.175
25% Charged	1.120	1.135
0% Charged	less than 1.100	less than 1.115

\* At 80°F

**NOTE:** Subtract .01 from the specific gravity reading at 40° F.

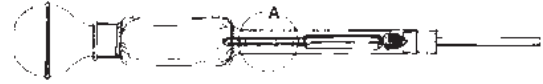

Polaris PN 2870876

**Detail A**

1.10
1.15
1.20
1.25
1.30

**LOAD TEST**

**CAUTION:** Remove spark plug high tension leads and connect securely to engine ground before proceeding.

**NOTE:** This test can only be performed on machines with electric starters. This test cannot be performed with an engine or starting system that is not working properly.

A battery may indicate a full charge condition in the OCV test and the specific gravity test, but still may not have the storage capacity necessary to properly function in the electrical system. For this reason, a battery capacity or load test should be conducted whenever poor battery performance is encountered. To perform this test, hook a multimeter to the battery in the same manner as was done in the OCV test. The reading should be 12.6 volts or greater. Engage the electric starter and view the registered battery voltage while cranking the engine. Continue the test for 15 seconds. During this cranking period, the observed voltage should not drop below 9.5 volts. If the beginning voltage is 12.6 or higher and the cranking voltage drops below 9.5 volts during the test, replace the battery.

## OFF SEASON STORAGE

To prevent battery damage during extended periods of non-use, the following basic battery maintenance items must be performed:

- Remove the battery from the machine and wash the case and battery tray with a mild solution of baking soda and water. Rinse with lots of fresh water after cleaning. **NOTE:** Do not get any of the baking soda into the battery or the acid will be neutralized.
- Using a wire brush or knife, remove any corrosion from the cables and terminals.
- Make sure that the electrolyte is at the proper level. Add distilled water if necessary.
- Charge at a rate no greater than 1/10 of the battery's amp/hr capacity until the electrolyte's specific gravity reaches 1.270 or greater.
- Store the battery either in the machine with the cables disconnected, or put it on a piece of wood and store in a cool place. **NOTE:** Stored batteries lose their charge at the rate of 1% per day. They should be recharged to a full charge every 30 to 60 days during a non-use period. If the battery is stored during the winter months the electrolyte will freeze at a higher temperature as the battery discharges. The chart at right indicates freezing points by specific gravity.

## CHARGING PROCEDURE

Charge the battery with a charger no larger than 1/10 of the battery's amp/hr rating for as many hours as needed to raise the specific gravity to 1.270 or greater.

Electrolyte Freezing Points	
Specific Gravity of Electrolyte	Freezing Point
1.265	-75° F
1.225	-35° F
1.200	-17° F
1.150	+5° F
1.100	+18° F
1.050	+27° F

1. Install battery in vehicle with positive terminal toward the front. Coat threads of battery bolt with Polaris corrosion resistant Nyogel™ grease.

**Polaris Nyogel™ Grease**

**PN 2871329**

### WARNING

To avoid the possibility of explosion, connect positive (red) cable first and negative (black) cable last.

2. Connect battery cables.
3. After connecting the battery cables, install the cover on the battery and attach the hold down strap.
4. Install clear battery vent tube from vehicle to battery vent. **WARNING:** Vent tube must be free from obstructions and kinks and securely installed. If not, battery gases could accumulate and cause an explosion. Vent should be routed away from frame and body to prevent contact with electrolyte. Avoid skin contact with battery electrolyte, severe burns could result. If electrolyte contacts the vehicle frame, corrosion will occur.
5. Route cables so they are tucked away in front and behind battery.

### ELECTRONIC PARTS

1. There are four (4) main electronic parts in the Scrambler 50 and Sportsman 90. They are: regulator, resistor...

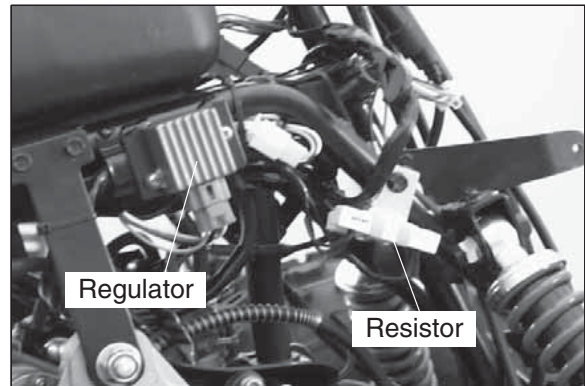

...C.D.I. unit, and ignition coil.

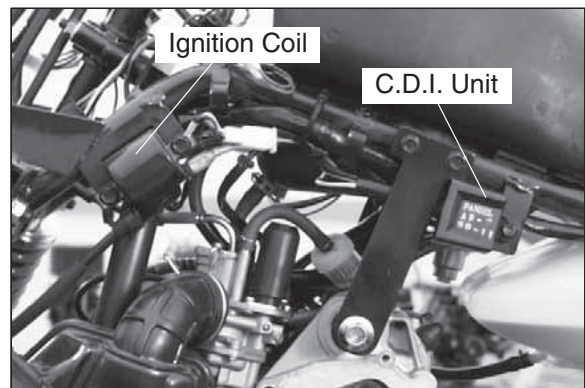

### CURRENT DRAW - KEY OFF

Connect an ammeter in series with the negative battery cable. Check for current draw with the key off. If the draw is excessive, loads should be disconnected from the system one by one until the draw is eliminated. Check component wiring as well as the component for partial shorts to ground to eliminate the draw.

**Current Draw - Key Off:  
Maximum of .02 DCA (20 mA)**

## CHARGING SYSTEM TESTING

**CAUTION:** Do not connect or disconnect the battery cable or ammeter with the engine running.

**CAUTION:** Never use the electric starter with the ammeter connected, or damage to the meter or meter fuse may result. Do not run test for extended period of time. Do not run test with high amperage accessories.

The “break even” point of the charging system is the point at which the alternator overcomes all system loads (lights, etc.) and begins to charge the battery. Depending on battery condition and system load, the break even point may vary slightly. The battery should be fully charged before performing this test.

- Connect an ammeter (set to DC amps) in series between the negative battery cable and terminal.
- Connect a tachometer according to manufacturer’s instructions.
- With engine off and the key and kill switch in the ON position, the ammeter should read negative amps (battery discharge). Reverse meter leads if a positive reading is indicated.
- Elevate machine so rear wheels are off the ground. Start engine with recoil *only*.
- Increase engine RPM while observing ammeter and tachometer.
- Note RPM at which the battery starts to charge (ammeter indication is positive).
- This should occur at approximately 1500 RPM or lower.
- Lock parking brake to keep brake light on.
- Repeat test, observing ammeter and tachometer. With lights on, charging should occur at or below 2000 RPM.

**Voltage: 13.5-15.5 V**

**Amperage: 1.0 A under 5000 RPM**

2. If the values do not meet the requirements, inspect the regulator/rectifier. Measure the resistance of each terminal and compare to chart at right. If any readings are different than shown, replace regulator/rectifier.

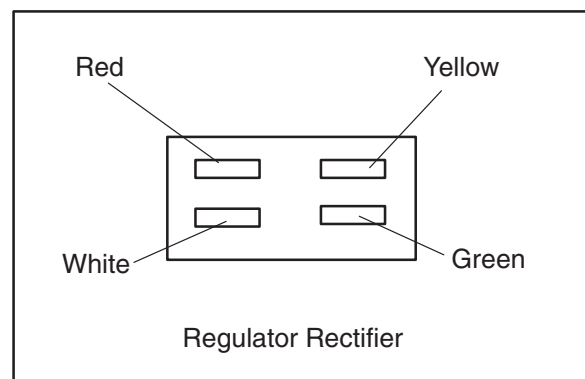
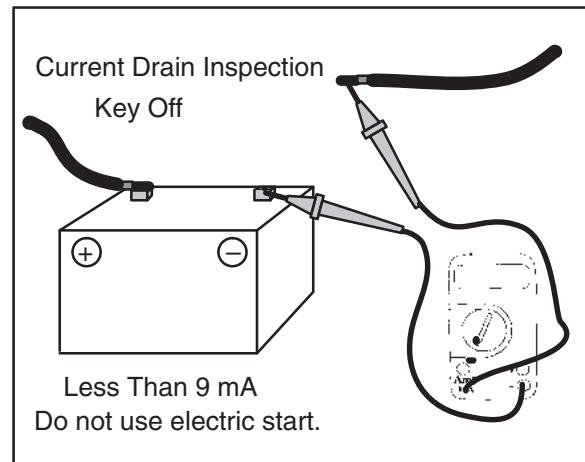

- Measure the resistance of each terminal.

	White	Yellow	Red	Green
White		$\infty$	8-10k	$\infty$
Yellow	$\infty$		$\infty$	33-35k
Red	$\infty$	$\infty$		$\infty$
Green	$\infty$	33-35k	$\infty$	

## IGNITION SYSTEM

### Ignition System Wiring Schematic

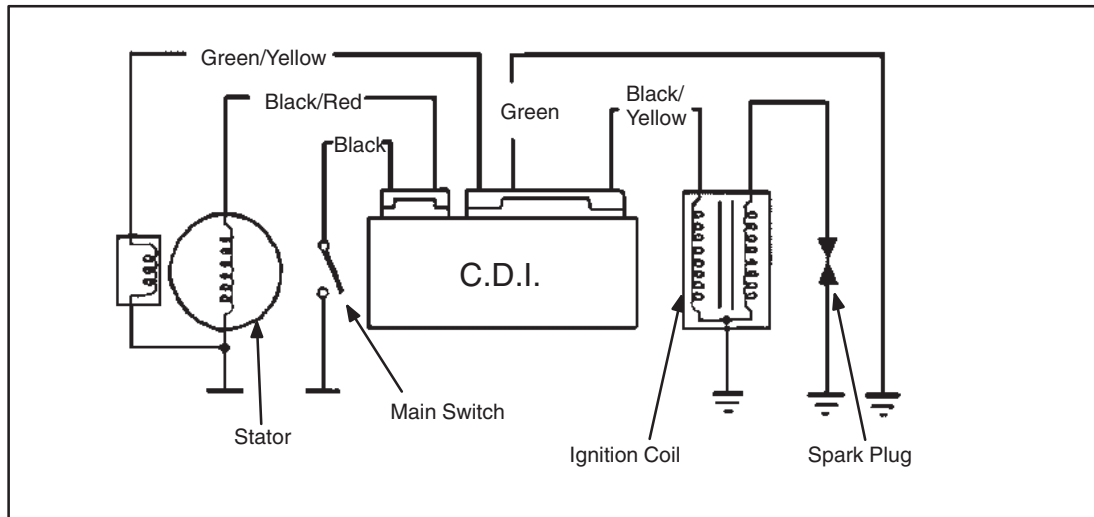

1. Ignition coil resistance: 0.2-0.3  $\Omega$ . If the resistance reads ( $\infty$ ) replace coil.
2. Measure the resistance between the spark plug cap and coil. Resistance should read 8.0-9.3 K $\Omega$  with cap installed.
3. Remove the spark plug cap and measure resistance again. Resistance should read 3.0-4.2 K $\Omega$  without cap.

## IGNITION TIMING

Ignition timing is fixed at 14 degrees at 1500 RPM on the Scrambler 50, and 16 degrees at 1500 RPM on the Scrambler 90 and Sportsman 90.

## IGNITION SYSTEM

Whenever troubleshooting an electrical problem you should first check all terminal connections to be sure they are clean and tight. Also be sure that colors match when wires are connected. Use the following pages as a guide for troubleshooting. The resistance values are also given on the specification pages.

Condition: No Spark or intermittent spark

Replace Spark Plug

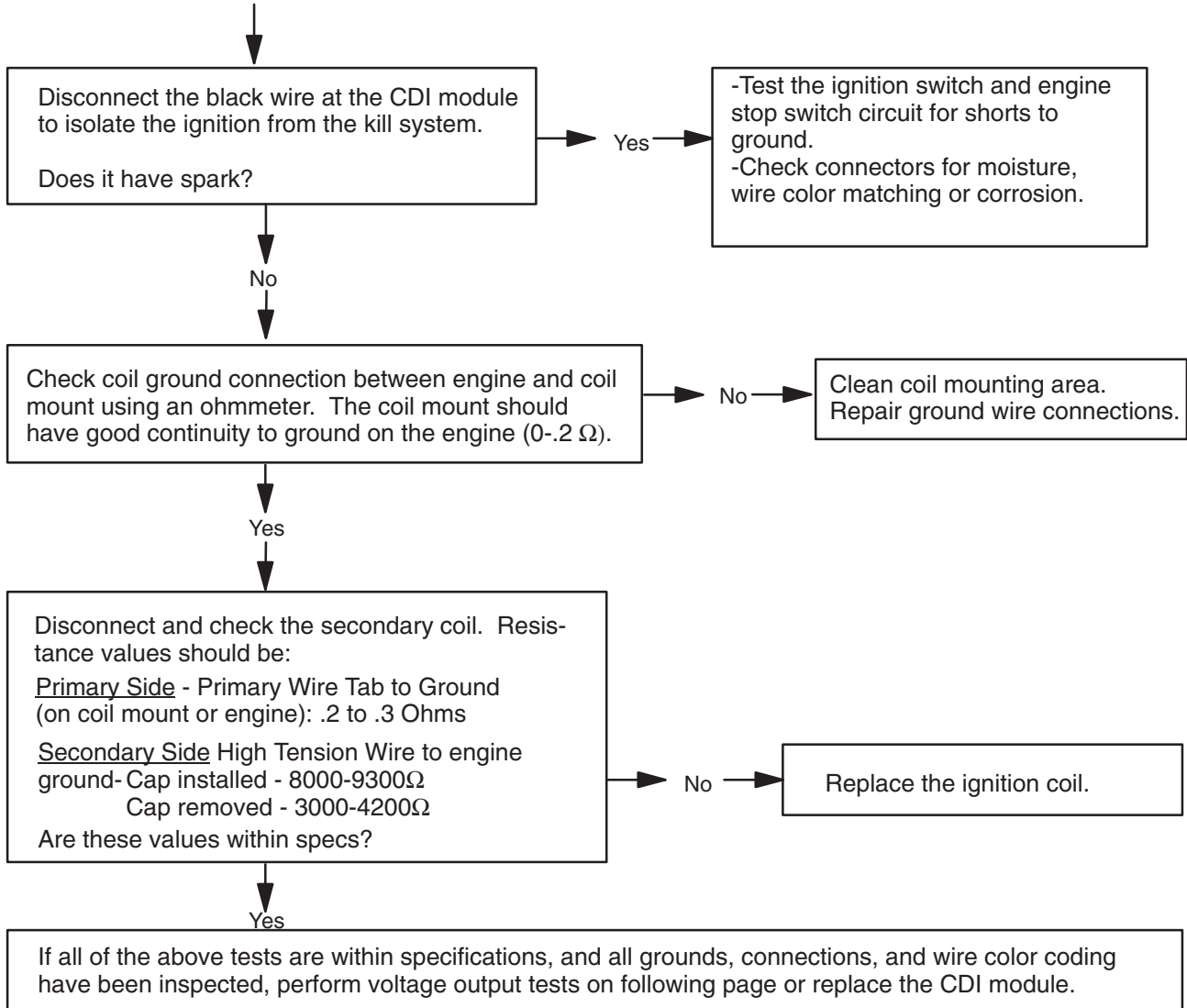

## **CRANKING OUTPUT TEST WITH PEAK READING VOLTMETER**

The following peak voltage tests will measure the amount of output directly from each component. A peak reading voltmeter must be used to perform the tests. A variety of peak reading adaptors are commercially available for use with the Fluke™ 73 Digital Multitester, Tektronix DMM155, and other digital VOMs which will allow peak voltage tests to be performed accurately. Follow the directions provided with the adaptor. All measurements are indicated in DC Volts. Readings obtained without a peak reading adaptor will be significantly different.

Disconnect the stator connectors from the CDI module. Test output from exciter coil, pulse (trigger) coil, and compare to the chart. The following measurements are obtained when cranking the engine with the electric starter, spark plug installed. The starter system must be in good condition and the battery fully charged.

<b>Coil</b>	<b>Connect Meter Wires To:</b>	<b>Reading (With Peak Reading Volt meter)</b>
Exciter 1	Black/Red and Red	34 DCV

## **CDI OUTPUT TEST USING PEAK READING ADAPTOR**

Re-connect all CDI wires to stator wires. Disconnect CDI module wire from ignition coil primary terminal. Connect one meter lead to engine ground and the other to the ignition coil primary wire leading from the CDI module. Crank engine and check output of CDI wire to coil (130 DCV). Reconnect coil wire to CDI.

**Output w/ Peak output tester  
130 DCV  
Average Output w/ Digital Voltmeter  
20 DCV**



## CHARGING SYSTEM TESTING

Whenever charging system problems are suspected, proceed with the following system check.

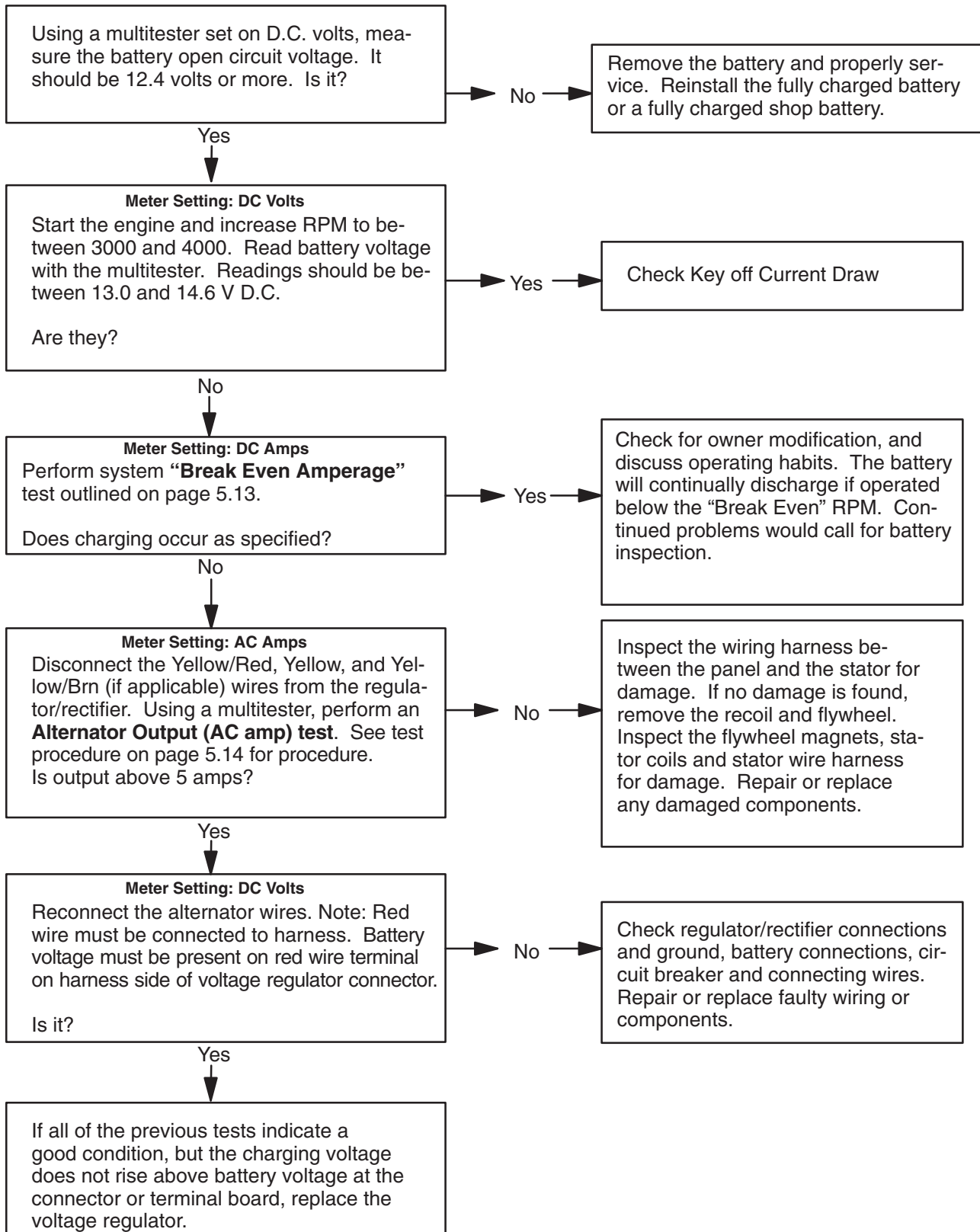

### CHARGING SYSTEM “BREAK EVEN” TEST

**CAUTION:** Do not connect or disconnect the battery cable or ammeter with the engine running.

**CAUTION:** Never use the electric starter with the ammeter connected, or damage to the meter or meter fuse may result. Do not run test for extended period of time. Do not run test with high amperage accessories.

The “break even” point of the charging system is the point at which the alternator overcomes all system loads (lights, etc.) and begins to charge the battery. Depending on battery condition and system load, the break even point may vary slightly. The battery should be fully charged before performing this test.

- Connect an ammeter (set to DC amps) in series between the negative battery cable and terminal.
- Connect a tachometer according to manufacturer’s instructions.
- With engine off and the key and kill switch in the ON position, the ammeter should read negative amps (battery discharge). Reverse meter leads if a positive reading is indicated.
- Elevate machine so rear wheels are off the ground. Start engine with recoil *only*.
- Increase engine RPM while observing ammeter and tachometer.
- Note RPM at which the battery starts to charge (ammeter indication is positive).
- With all electrical loads off, this should occur at approximately 1500 RPM or lower.
- Lock parking brake to keep brake light on.
- Repeat test, observing ammeter and tachometer. With tail light on, charging should occur at or below 2000 RPM.

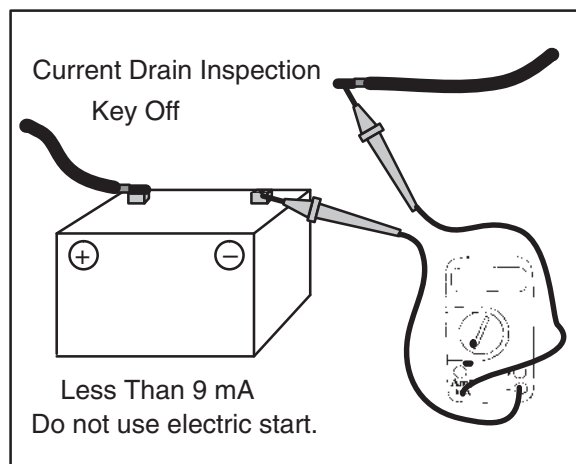

## ALTERNATOR OUTPUT TEST (AC AMP)

This test measures AC amperage from the alternator.

- Maximum alternator output will be indicated on the meter. It is *not* necessary to increase engine RPM above idle.
- Place the red lead on the tester in the 10A jack.
- Turn the selector dial to the AC amps (A~) position.
- Connect the meter leads to the Yellow and Yellow/Red wires leading from the alternator.
- Start the engine and let it idle. Reading should be a minimum of 5A at idle.

**CAUTION:** This test simulates a “full load” on the alternator. Do not perform this test longer than required to obtain a reading or the alternator stator windings may overheat. 10-15 seconds is acceptable.

**Alternator Current Output:  
Minimum of 5 AC Amps**

### To Calculate Available Alternator Output

$$I = \frac{P}{E} \quad \frac{70W}{12V} = 5.8 \text{ Amps}$$

I = Current in Amps

P = Power in Watts

E = Electromotive Force (Volts)

## STARTER SYSTEM TROUBLESHOOTING

### **Starter Motor Does Not Turn**

- Battery discharged - low specific gravity
- Loose or faulty battery cables or corroded connections (see Voltage Drop Tests)
- Related wiring loose, disconnected, or corroded
- Poor ground connections at battery cable, starter motor or starter solenoid (see Voltage Drop Tests)
- Faulty starter button
- Faulty ignition switch (Do other systems function?)
- Faulty starter solenoid or starter motor.
- Engine problem - seized or binding (Can engine be rotated easily with recoil starter?)

### **Starter Motor Turns Over Slowly**

- Battery discharged - low specific gravity
- Excessive circuit resistance - poor connections (see Voltage Drop Test below)
- Engine problem - seized or binding (Can engine be rotated easily with recoil starter?)
- Faulty or worn brushes in starter motor
- Automatic compression release inoperative

### **Starter Motor Turns - Engine Does Not Rotate**

- Faulty starter drive
- Faulty starter drive gears or starter motor gear
- Faulty flywheel gear or loose flywheel

## VOLTAGE DROP TEST

The Voltage Drop Test is used to test for bad connections. When performing the test, you are testing the amount of voltage drop through the connection. A poor or corroded connection will appear as a high voltage reading. Voltage shown on the meter when testing connections should not exceed .1 VDC per connection or component.

To perform the test, place the meter on DC volts and place the meter leads across the connection to be tested. Refer to the chart on next page to perform voltage drop tests on the starter system.

**Voltage should not exceed:  
.1 DC volts per connection**

## STARTER SYSTEM

Condition: Starter fails to turn motor. **NOTE:** Make sure engine crankshaft is free to turn before proceeding with dynamic testing of starter system. A digital multimeter must be used for this test.

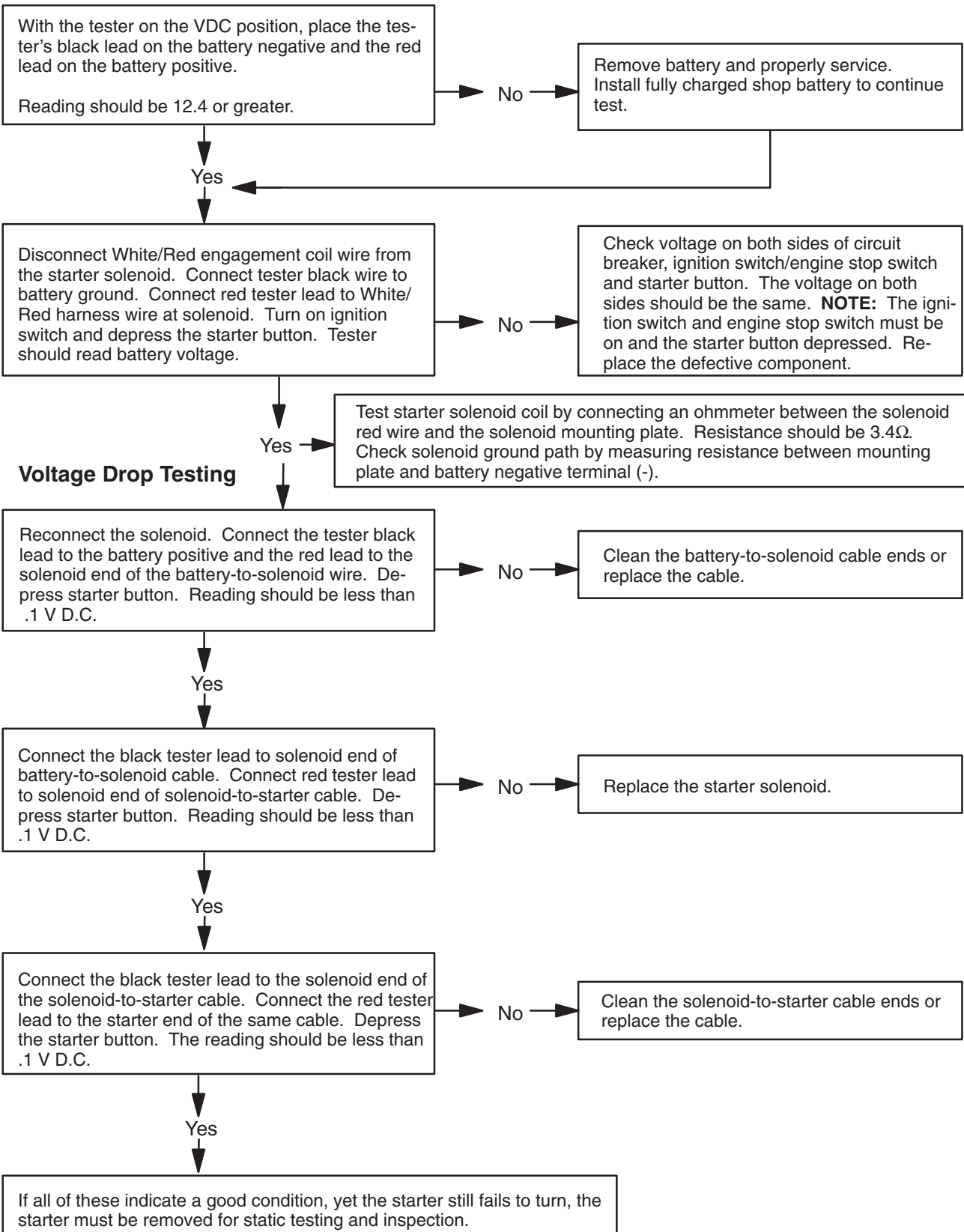

### STARTER MOTOR DISASSEMBLY

**NOTE:** Use electrical contact cleaner to clean starter motor parts. Some solvents may leave a residue or damage internal parts and insulation.

1. Note the alignment marks on both ends of the starter motor casing. These marks must align during reassembly.

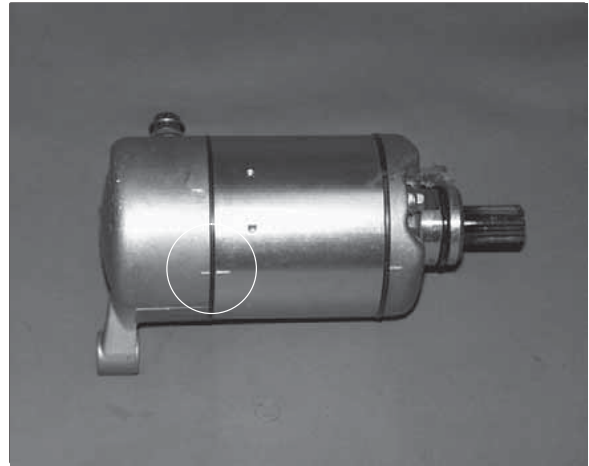

2. Remove the two bolts, washers, and sealing O-Rings. Inspect O-Rings and replace if damaged.

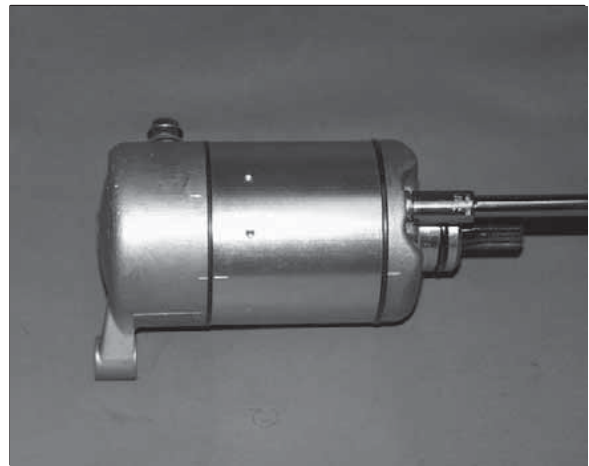

3. Remove brush terminal end of housing while holding other two sections together.

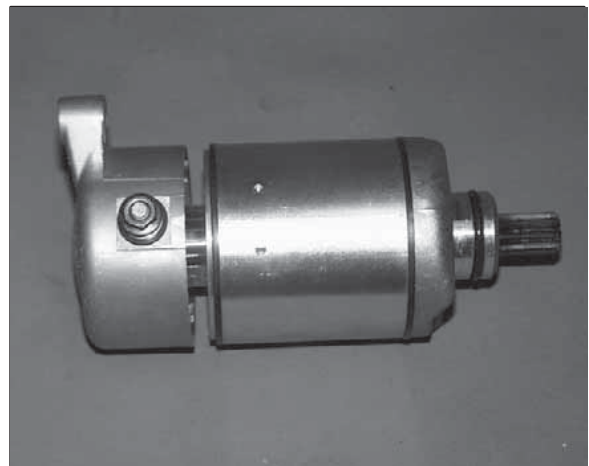

## STARTER MOTOR DISASSEMBLY, CONT.

4. Remove shims from armature shaft. **NOTE:** All shims must be replaced during reassembly.

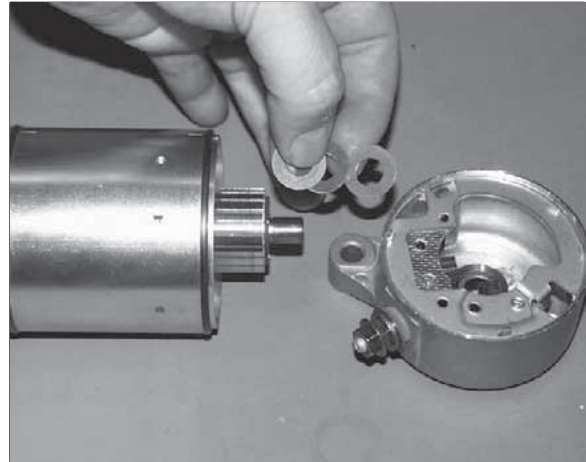

## BRUSH INSPECTION/REPLACEMENT

- Using a digital multimeter, measure the resistance between the cable terminal and the insulated brush. The reading should be .3 ohms or less. Measure the resistance between the cable terminal and brush housing. Make sure the brush is not touching the case. The reading should be infinite.
- Remove nut, flat washer, large phenolic washer, two small phenolic washers, and O-Ring from brush terminal. Inspect the O-Ring and replace if damaged.
- Remove brush plate and brushes. Measure length of brushes and replace if worn past the service limit. Replace springs if they are discolored or have inadequate tension.

**Brush Length Service Limit:**  
5/16" (.8 cm)

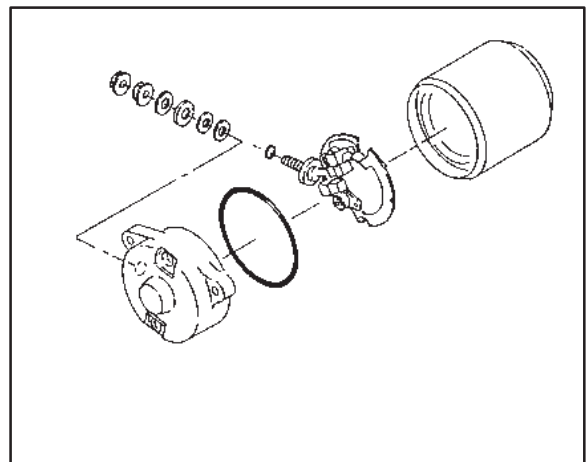

- Inspect surface of commutator for wear or discoloration. See steps 3-6 of armature testing on page 5.18.
- Install a new carbon brush assembly in the brush housing. **NOTE:** Be sure that the terminal bolt insulating washer is properly seated in the housing, and the tab on the brush plate engages the notch in the brush plate housing.

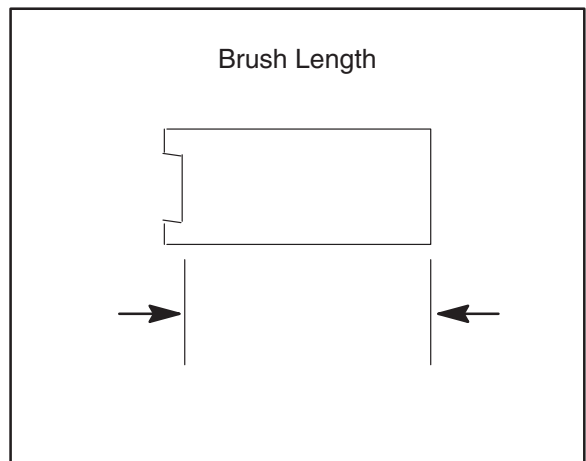

### BRUSH INSPECTION/REPLACEMENT, CONT.

6. Place a wrap of electrical tape on the threads of the terminal bolt to prevent O-Ring damage during reinstallation.
7. Install the O-Ring over the bolt. Make sure the O-ring is fully seated.
8. Remove the electrical tape and reinstall the two small phenolic washers, the large phenolic washer, flat washer, and nut.

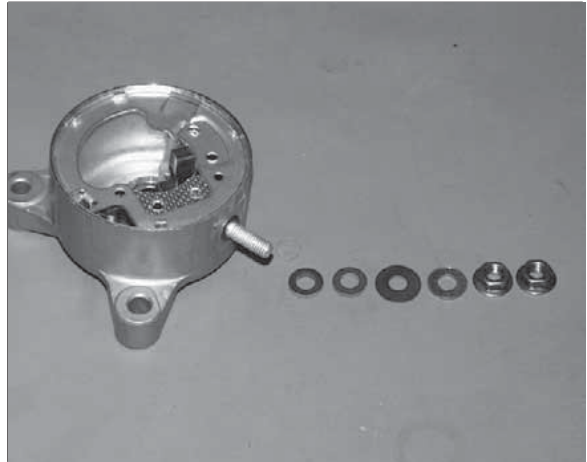

### ARMATURE TESTING

1. Remove armature from starter casing. Note order of shims on drive end for reassembly.
2. Inspect surface of commutator. Replace if excessively worn or damaged.
3. Using a digital multimeter, measure the resistance between each of the commutator segments. The reading should be .3 ohms or less.

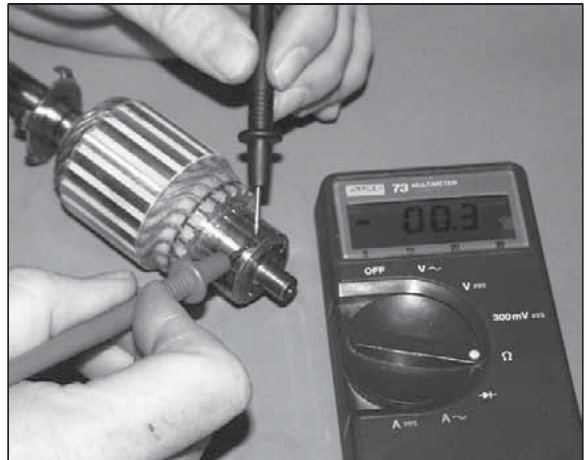

4. Measure the resistance between each commutator segment and the armature shaft. The reading should be infinite (no continuity).
5. Check commutator bars for discoloration. Bars discolored in pairs indicate shorted coils, requiring replacement of the starter motor.
6. Place armature in a growler. Turn growler on and position a hacksaw blade or feeler gauge lengthwise 1/8" (.3 cm) above armature coil laminates. Rotate armature 360°. If hacksaw blade is drawn to armature on any pole, the armature is shorted and must be replaced.

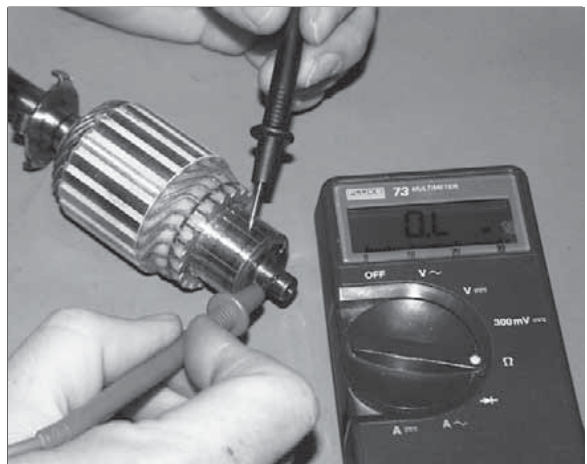



## STARTER ASSEMBLY

1. Place armature in field magnet casing.
2. Place shims on drive end of armature shaft with phenolic washer outermost on shaft. Engage tabs of stationary washer in drive end housing, holding it in place with a light film of grease.
3. Inspect permanent magnets in starter housing. Make sure they are not cracked or separated from housing.
4. Install case sealing O-Ring. Make sure O-Ring is in good condition and not twisted on the case. Lubricate needle bearing and oil seal with a light film of grease, and install housing, aligning marks.
5. Install O-Ring on other end of field magnet casing. Make sure it is in good condition and not twisted on the case.
6. Align casing marks and install housing, pushing back brushes while installing shaft in bushing.
7. Reinstall starter motor housing bolts. Make sure O-Rings are in good condition and seated in groove.

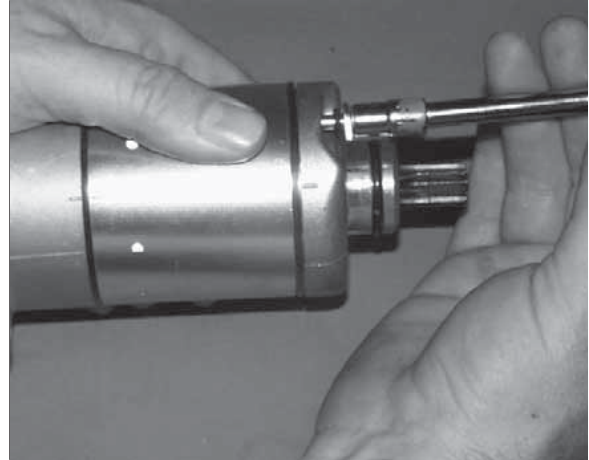

### **CAUTION:**

Use care when handling starter housing. Do not drop or strike the housing as magnet damage is possible. If magnets are damaged, starter must be replaced.

### **Starter Solenoid Bench Test**

It is difficult to test the high amp side of the solenoid accurately on the bench. The only test which can be done on the bench is the pull-in coil resistance. The reading should be 3.4 ohms.

## ELECTRONIC THROTTLE CONTROL (ETC)

The Electronic Throttle Control (ETC) system is designed to limit the engine RPM of an ATV in the event of a mechanical problem with the throttle mechanism. The ETC switch is mounted independently of the throttle actuator lever inside the throttle block assembly. This is a normally closed switch, and is held in the open position (micro switch button depressed) by throttle cable tension. The switch is “open” in normal operation regardless of throttle lever position. In the event of a mechanical problem in the throttle mechanism (cable tension is lost), the switch contacts close (switch pin is released) delivering battery voltage to the Speed Limiter module via the white wire. Battery voltage on the white wire will cause the ignition system to misfire at the “ETC Limit”.

Test the ETC switch at the harness connector. **NOTE:** Adjust throttle cable freeplay (ETC switch) and make sure throttle mechanism is functioning properly before testing the switch. Refer to Maintenance Chapter 2 for cable adjustment procedure. Terminal board models - Disconnect White wire on terminal board that leads from the ETC switch. Turn ignition key (and engine stop switch) “On”. If voltage is present on the White wire and throttle cable is adjusted properly, replace the ETC switch.

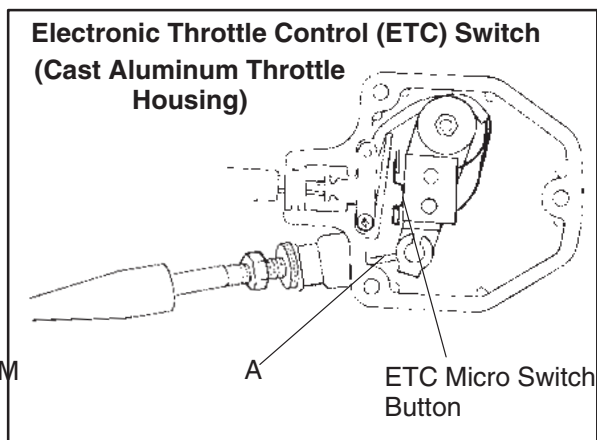
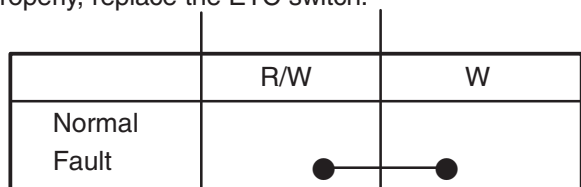

### ETC Operation Test

Remove throttle block cover.

Place transmission in neutral and apply parking brake.

Start engine and open throttle lever slightly until engine RPM is above the “ETC Limit” (see page 10.37 for LR module ETC limits).

Hold throttle cable with fingers at point “A” as shown at right and release throttle lever. If the ETC system is functioning properly engine RPM will be limited to the specified “ETC Limit” RPM.

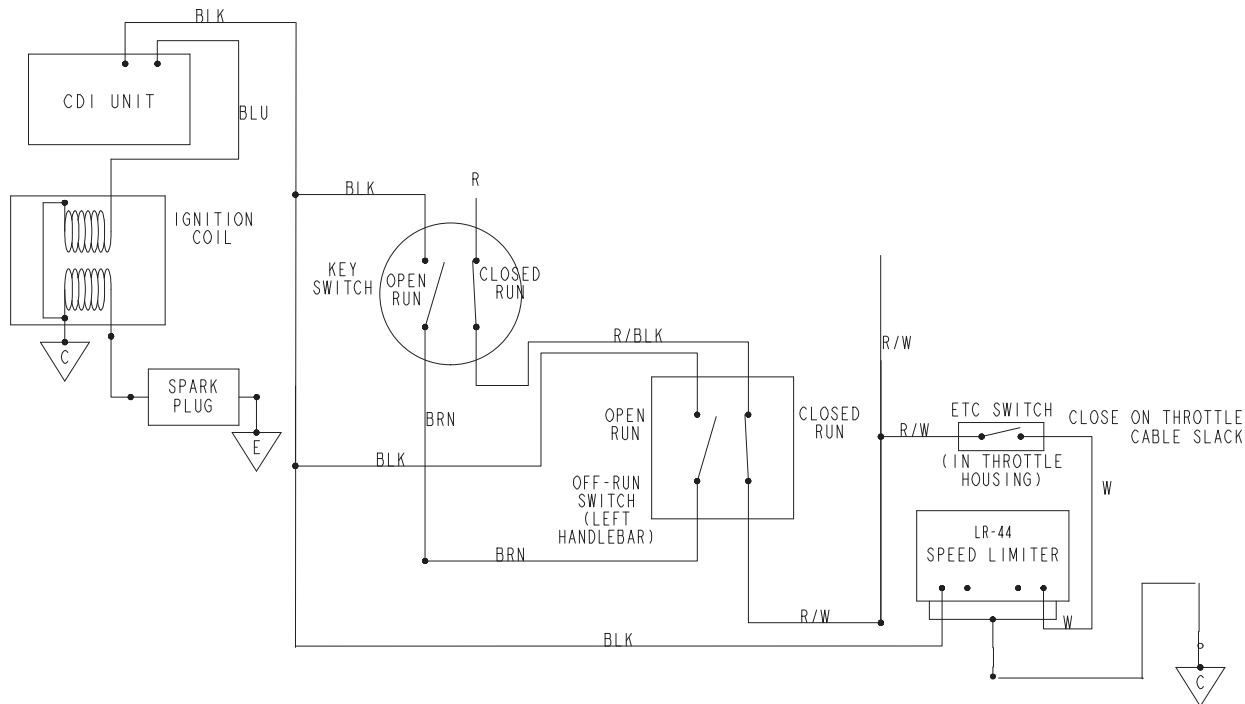

## IGNITION SYSTEM TROUBLESHOOTING

### **No Spark, Weak or Intermittent Spark**

- Spark plug gap incorrect
- Fouled spark plug
- Faulty spark plug cap or poor connection to high tension lead
- Related wiring loose, disconnected, shorted, or corroded
- Engine Stop switch or ignition switch faulty
- ETC switch misadjusted or faulty
- Terminal board or connections wet, corroded
- Poor ignition coil ground (e.g. coil mount loose or corroded)
- Faulty stator (measure resistance of all ignition related windings)
- Incorrect wiring (inspect color coding in connectors etc)
- Faulty ignition coil winding (measure resistance of primary and secondary)
- Worn magneto (RH) end Crankshaft bearings
- Sheared flywheel key
- Flywheel loose or damaged
- Excessive crankshaft runout on magneto (RH) end - should not exceed .0024"
- Faulty CDI module

# ELECTRICAL

## WIRING DIAGRAM, 2001 SCRAMBLER 50

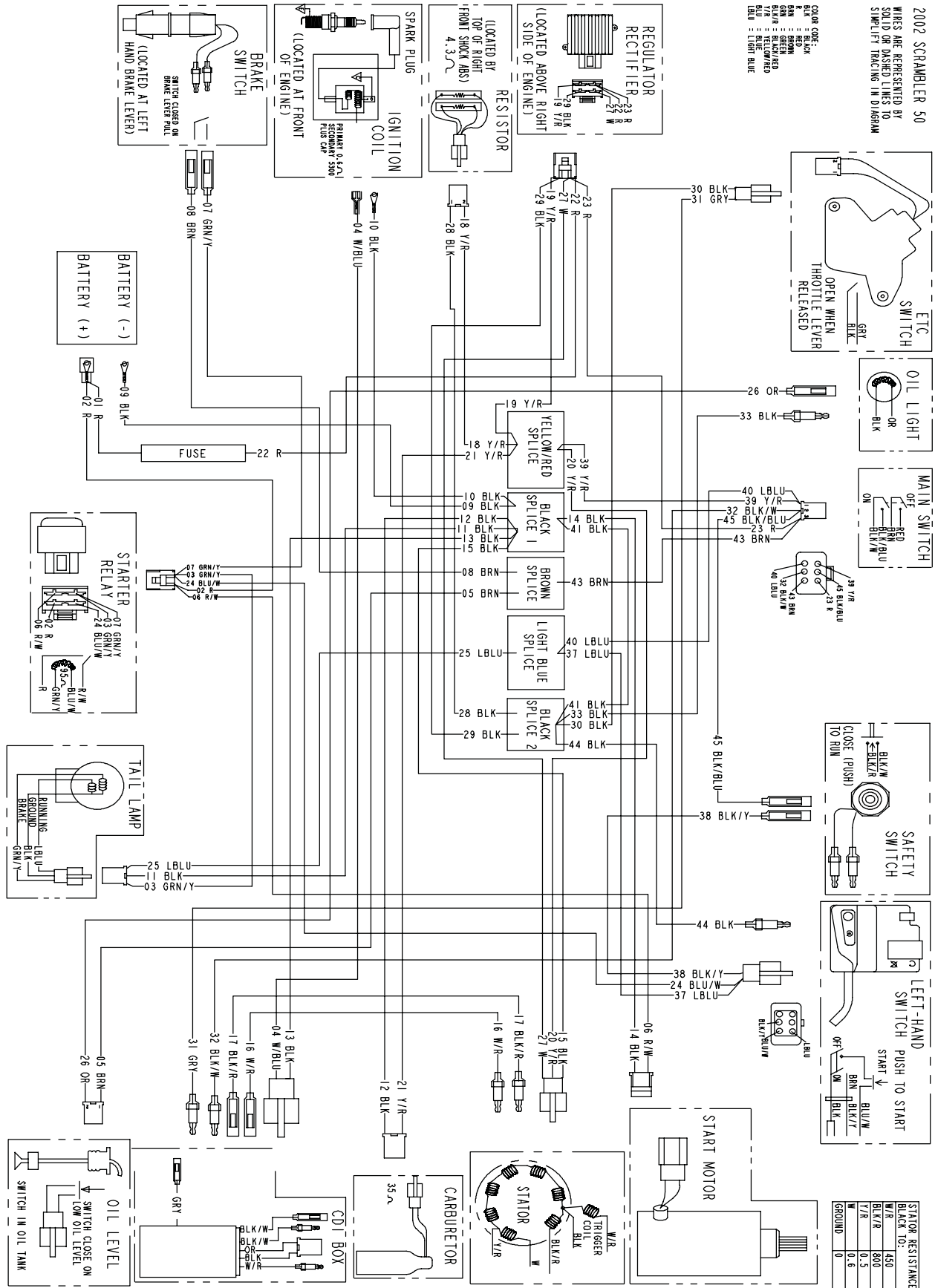

WIRING DIAGRAM 2001 SCRAMBLER 90, SPORTSMAN 90

