

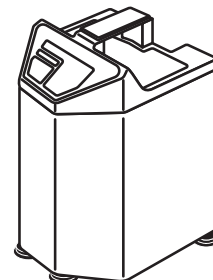

# Bair Hugger\*

Model 505 Warming Unit

## Service Manual



**Warning:** Electrical Shock Hazard. There are electrically live parts within the warming unit when it is connected to a power source, even when the switches are in the *OFF* or *STANDBY* position.

**Please forward to Biomedical Engineering Department**



**BAIR HUGGER MODELL 505 TEMPERATURMANAGEMENTGERÄT SERVICE GEBRAUCHSANLEITUNG**

**Vorsicht:** Gefährliche elektrische Spannung. In einem an das Stromnetz angeschlossenen Wärmegerät stehen bestimmte elektrische Komponenten auch dann unter Strom, wenn der Schalter auf *AUS* oder *BEREITSCHAFTSMODUS* geschaltet ist.

**Bitte an die Abteilung für biomedizinische Technik weiterleiten**



**UNITÉ DE GESTION DE TEMPÉRATURE BAIR HUGGER MODÈLE 505 SERVICE MANUEL**

**Mise en garde :** Risque d'électrocution. Certaines pièces sont électriquement chargées dans les appareils de réchauffement, lorsque ceux-ci sont connectés à une source d'alimentation et ce, même si l'appareil est en position *OFF* (arrêt) ou *STANDBY* (attente).

**A transmettre au Service d'ingénierie biomédicale**



**Total Temperature Management System**



# **Bair Hugger\***

Model 505 Warming Unit

## **Service Manual**

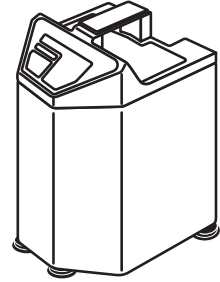

**English 1**

**Deutsch 29**

**Français 61**

# Table of Contents

---

<b>Introduction</b> .....	1
Description of the Total Temperature Management* System .....	1
Indications .....	1
Contraindications .....	1
Warnings .....	2
Cautions .....	3
Notices .....	3
Read Before Servicing Equipment .....	4
<b>Service Procedures</b> .....	5
Cabinet Cleaning .....	5
Hose Replacement .....	5
Power Fuse Replacement .....	6
Control Board Fuse Replacement .....	7
Air Filter Replacement .....	9
Over Heat Alarm Testing .....	10
Over Heat Alarm Thermostat Adjustment .....	13
Normal Operating Temperature Testing .....	15
Normal Operating Temperature Adjustment .....	17
<b>Specifications</b> .....	19
<b>Key to Figure 10.</b> .....	20
<b>Technical Support and Customer Service</b> .....	22
When You Call for Technical Support .....	22
In-Warranty Repair and Exchange USA .....	22
Returning Units for Service .....	23
<b>Troubleshooting</b> .....	24
<b>Maintenance Log</b> .....	25
<b>Symbol Definitions</b> .....	28

---



# Introduction

---

## Description of the Total Temperature Management\* System

The Bair Hugger brand Total Temperature Management system consists of a Bair Hugger forced-air warming unit and disposable components, including Bair Hugger forced-air blankets and the 241\* blood/fluid warming set, and Bair Paws\* patient warming gowns. The system and disposables are intended for use in clinical settings including the operating room. The warming unit draws ambient air through a filter and warms the air to the specified temperature. It then delivers the warmed air through a hose to the blanket or gown.

This manual describes how to service the Model 505 warming unit, and includes maintenance instructions and specifications. For information about using Bair Hugger blankets, the 241 blood/fluid warming set, or Bair Paws gowns with Bair Hugger units, refer to the “Instructions for Use” included with each of these disposable components.

## Indications

The Bair Hugger Temperature Management system is intended to prevent and treat hypothermia. In addition, the temperature management system can be used to provide patient thermal comfort when conditions exist that may cause patients to become too warm or too cold. The temperature management system can be used with adult and pediatric patients.

## Contraindications

Do not apply heat to lower extremities during aortic cross-clamping. Thermal injury may occur if heat is applied to ischemic limbs.

## Warnings



1. Do not leave patients with poor perfusion unmonitored during prolonged warming therapy sessions. Thermal injury may result.
2. The Bair Hugger temperature management unit has been designed to operate safely ONLY with Arizant Healthcare\* disposable components. Use with other products may cause thermal injury. (To the full extent permitted by law, the manufacturer and/or importer declines all responsibility for thermal injury resulting from the unit being used in conjunction with non-Arizant Healthcare products.)
3. Do not warm patients with the temperature management unit hose alone. Thermal injury may result. Always connect the hose to a Bair Hugger blanket or Bair Paws gown before providing therapy.
4. Do not place the non-perforated side of the blanket on the patient. Thermal injury may result. Always place the perforated side (that is, with small holes) towards the patient.
5. Do not continue temperature management therapy if the over-temp indicator light illuminates and the alarm sounds. Thermal injury may result. Unplug the unit, and contact a qualified service technician.
6. Do not continue 241 blood/fluid warming therapy if the over-temp indicator light illuminates and the alarm sounds. Immediately stop fluid flow, and discard the blood/fluid warming set. Unplug the temperature management unit, and contact a qualified service technician.
7. Do not use a forced-air warming device over transdermal medication. Increased drug delivery and patient injury or death may occur.
8. Do not allow the patient to lie on the warming unit hose or allow the hose to directly contact the patient's skin during patient warming; thermal injury may result.
9. Equipment not suitable for use in the presence of a flammable anesthetic mixture with air or with oxygen or nitrous oxide.
10. Resuable blankets made from woven fabric, or blankets without discrete, visible holes, can cause the safety system of this unit to fail, which may result in serious thermal injury. This warming unit has been designed to operate safety ONLY with Bair Hugger blankets and Bair Paws gowns.

## Cautions

1. Except for specific blanket models, Bair Hugger blankets are not sterile and are all intended for single patient use ONLY. Placing a sheet between the Bair Hugger blanket and the patient does not prevent contamination of this product.
2. Monitor the patient's temperature and cutaneous response every 10-20 minutes or according to institutional protocol and monitor the patient's vital signs regularly. Adjust air temperature or discontinue therapy when the therapeutic goal is reached or if vital sign instability occurs. Notify physician of vital sign instability immediately.
3. Do not leave pediatric patients unattended during therapy.
4. Do not initiate temperature management therapy unless the temperature management unit is safely placed on a hard surface or securely mounted. Otherwise, injury may result.
5. To prevent tipping, clamp the Temperature Management Unit to an IV pole at a height that provides stability. We recommend clamping the unit no higher than 44" (112cm) on an IV pole with a minimum 14" (35cm) radius wheelbase. Failure to do so may result in IV pole tipping, catheter site trauma, and patient injury.
6. Electrical shock hazard. Do not disassemble the temperature management unit unless you are a qualified service technician. There are electrically live parts within the unit when it is connected to a power source, even when the unit is in Standby mode.

## Notices

1. The Bair Hugger temperature management unit meets medical electronic interference requirements. If radio frequency interference with other equipment should occur, connect the unit to a different power source.
2. Federal law (USA) restricts this device to sale by or on the order of a licensed healthcare professional.
3. To reliably ground this Bair Hugger warming unit, only connect to receptacles marked "Hospital Only" or "Hospital Grade".

## Read Before Servicing Equipment

The repair, calibration, and servicing of the warming unit requires the skill of a qualified medical equipment service technician who is familiar with good practice for medical device repair. If service is designated as not requiring manufacturer's attention, the technical information is provided in this service manual or will be provided, on request, by Arizant Healthcare Inc.

### Refer to Service Manual

---

Perform all repairs and maintenance in accordance with the instructions in this service manual.

### Safety Inspection

---

Perform a safety inspection after making repairs to the Bair Hugger warming unit and before returning the warming unit to service. A safety inspection should include a test of the operating temperatures (described in this service manual), the Over Heat alarm system, as well as a leakage current test.

### Proper Use and Maintenance

---

Arizant Healthcare Inc. assumes no responsibility for the reliability, performance, or safety of the equipment if:

- Modifications or repairs are performed by non-authorized personnel.
- The equipment is used in a manner other than that described in the Operator's or Service Manuals.
- The equipment is installed in an environment that does not meet the relevant grounding requirements.

# Service Procedures

---

## Cabinet Cleaning

### Tools/Equipment

---

Soft cloth, *lightly* dampened with water and mild detergent.

### Method

---

1. Disconnect the warming unit from the power source.
2. Wipe the exterior of the warming unit clean.



**CAUTION:** Do not use a dripping wet cloth when cleaning the warming unit. Moisture may seep into the electrical contacts and damage the components. Also, do not use alcohol or other solvents to clean the cabinet. Solvents may damage the labels and other plastic parts.

## Hose Replacement

### Method

---

1. Press the tab on the blower outlet to release the existing hose.
2. Attach the replacement hose by inserting the flange end at a 45° angle in the grooved blower outlet, then snap the hose into place. (See Figure 1.)

**Figure 1. Attaching the Replacement Hose**

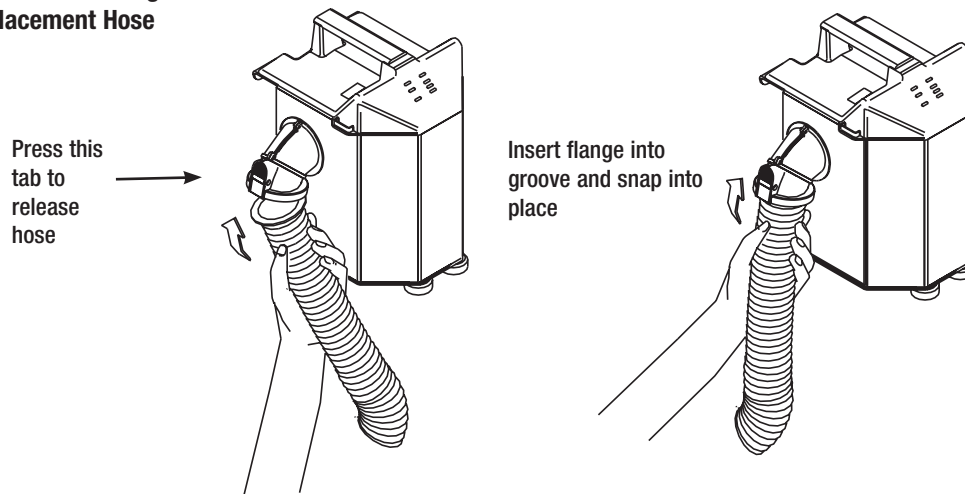



## Power Fuse Replacement

The power fuses are located in the power entry module. A spare fuse is located in the fuse carrier (see Figure 2).

### Tools/Equipment

Phillips-head screwdriver  
Small slotted screwdriver

### Method

1. Disconnect the warming unit from the power source.
2. Remove the 2 Phillips-head screws that secure the cord retainer. Remove the power cord.
3. Locate the fuse carrier in the center of the power entry module (see Figure 2).
4. Use the small screwdriver to remove the fuse carrier from the power entry module.
5. Remove the blown fuse(s) from the fuse carrier.
6. Place the new fuse(s) (as marked) into the fuse carrier.



**CAUTION:** Replace only with the fuse capacity and type that is indicated on the adjacent label.

7. Replace the fuse carrier into the power entry module.
8. Reattach the power cord.
9. Replace the 2 Phillips-head screws to reattach the cord retainer.
10. Reconnect the warming unit to the power source.
11. Record the maintenance action taken and the hours of operation (read from the hour meter) in the *Maintenance Log* section.

Figure 2. Location of Power Fuse

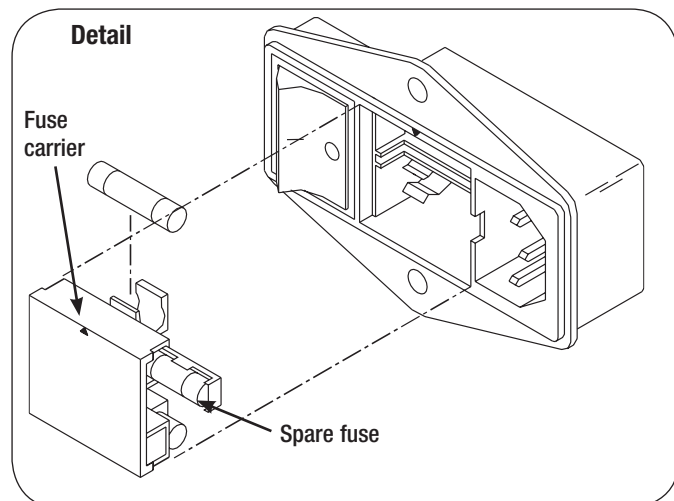
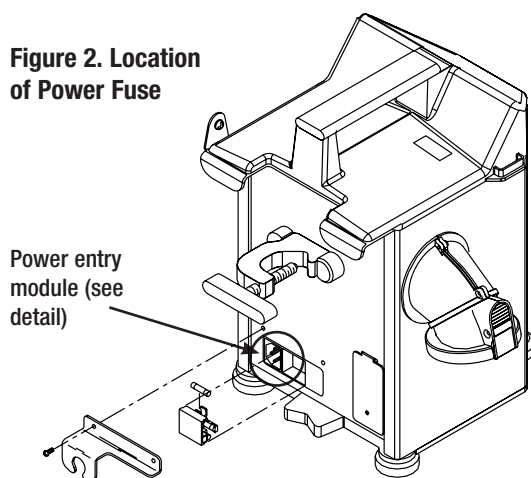

## Control Board Fuse Replacement

Control board fuses are located on the control board. (See Figure 3.) The internal fuses on the Model 505 are for control board functions only.

The power fuses are located in the power entry module. Instructions for power fuse replacement can be found in the *Power Fuse Replacement* section.

### Tools/Equipment

---

Phillips-head screwdriver

### Method

---

1. Disconnect the warming unit from the power source.
2. Turn the Model 505 unit over, so that the bottom panel is facing up.
3. Using the Phillips-head screwdriver, remove the screw from each of the 2 front feet (bumpers) and remove the feet.
4. Remove the Phillips-head screw from the center of the upper rear panel.
5. Remove the 2 Phillips-head screws located under the bed hooks on the upper rear panel. Turn the unit right side up.
6. Lift the top cover and unhook the front of the top cover from the retainer bracket inside. The control panel is located on the underside of the top cover. See Figure 3 for location of the fuse.
7. Remove the fuse and replace with the new one.



**CAUTION:** Replace only with the fuse capacity and type that is indicated on the adjacent label.

### Control Board Fuse Replacement

8. Hook the retainer bracket onto the front of the top cover.
9. Place the top cover back into position. Replace all screws.

**NOTE:** It may be necessary to remove the air filter to correctly position the lower portion of the retainer bracket inside the unit.
10. Reconnect the warming unit to the power source.
11. Record the maintenance action taken and the hours of operation (read from the hour meter) in the *Maintenance Log* section.

**Figure 3. Location of Control Board Fuse**

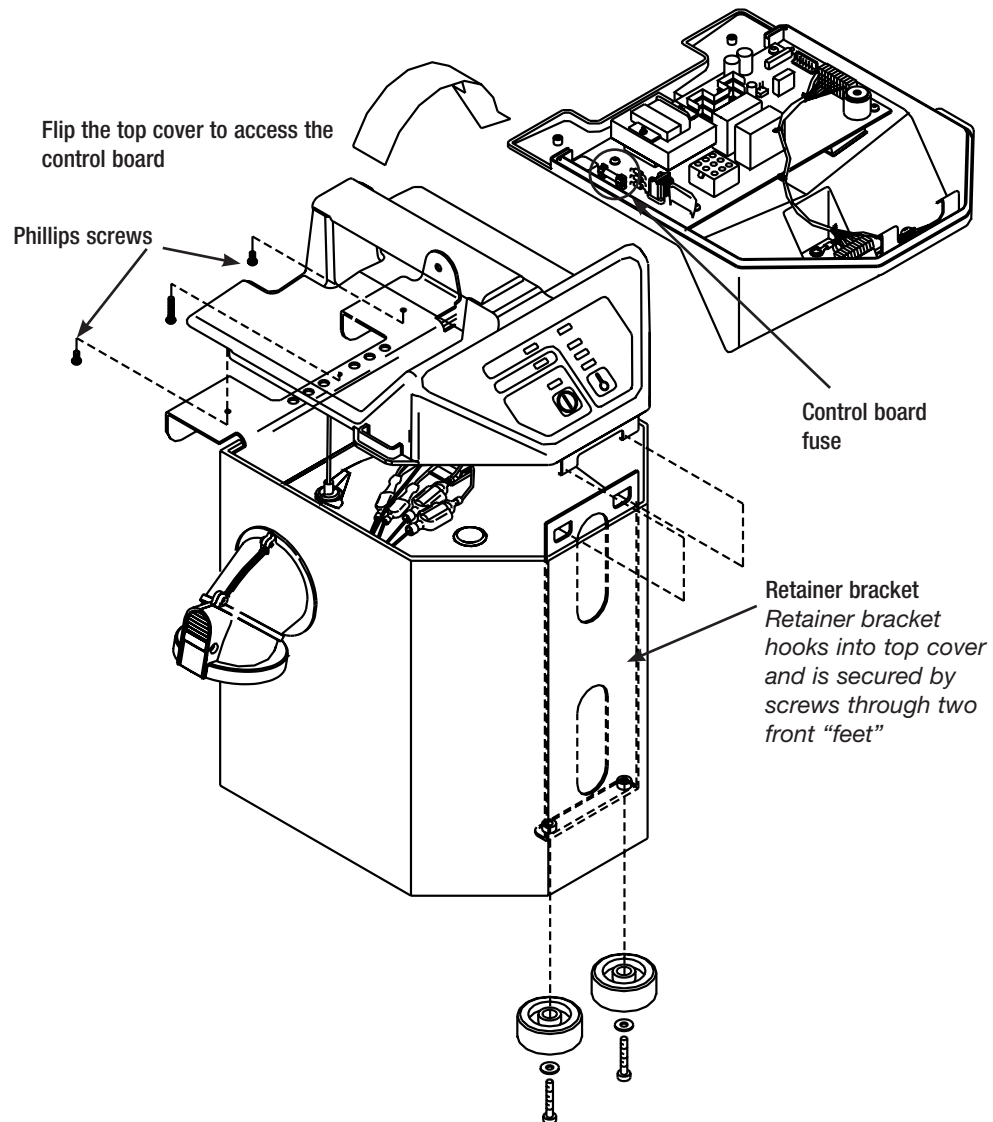

## Air Filter Replacement

The air filter is mounted in the bottom of the warming unit (See Figure 4).

### Tools/Equipment

---

Phillips-head screwdriver

### Service Frequency

---

Every 6 months or 500 hours of use.

### Method

---

1. Disconnect the warming unit from the power source.
2. Remove the M6 x 25 pan-head screw on the bottom on the unit. The filter should slide out easily.
3. Record the hour meter reading and date on the new air filter label. The hour meter is located in the lower left corner of the top warming label (see Figure 4).
4. Slide the new filter into the base of the unit.
5. Replace the M6 x 25 pan-head screw on the bottom on the unit.
6. Reconnect the warming unit to the power source.
7. Record the hour meter reading and maintenance action taken in the *Maintenance Log* section.

**Figure 4. Location of Air Filter and Hour Meter**

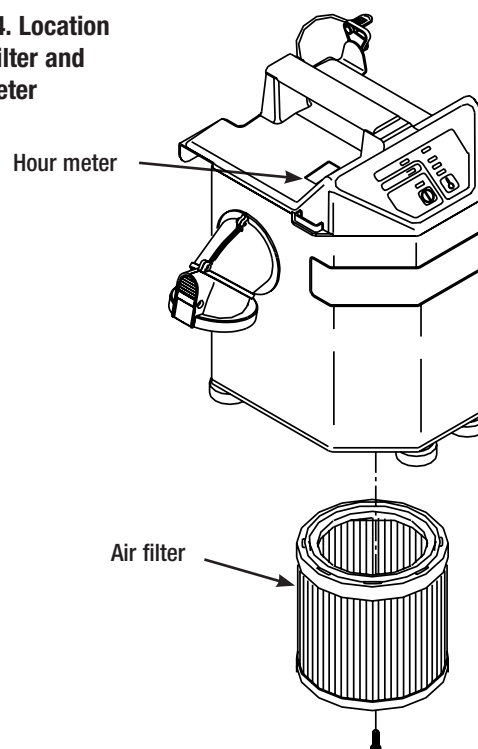

## Over Heat Alarm Testing



**WARNING:** Perform all testing and adjustments of warming unit temperature with a calibrated Model 221 Temperature test kit or a Model 22110 Temperature test unit. Arizant Healthcare Inc. assumes no responsibility for the reliability, safety, or performance of the Bair Hugger system if warming unit temperature testing or adjustments are made in any other manner than that described here. Improper measurement or adjustment of the warming unit's over heat alarm setting could result in patient exposure to temperatures outside of the indicated range, and may lead to patient injury.

**NOTE:** The Model 221 Temperature Test Kit and the Model 22110 Temperature Test Unit are designed to simulate the operating characteristics of Bair Hugger blankets and Bair Paws gowns when used with Bair Hugger warming units; use of the temperature test device with any other warming system may result in imprecise readings.

*If using the Model 221 Test Kit, temperature readings are taken from the test kit itself. If using the Model 22110 Test Unit, temperature readings are taken from a calibrated temperature meter.*

---

### Service Frequency

6-month intervals or 500 hours of use

---

### Tools/Equipment

Phillips-head screwdriver

*If using the Model 22110 Temperature Test Unit:*

- Use a calibrated temperature meter that can accept a male subminiature connector and read a K style thermocouple (e.g., a Fluke Model 52 K/J Thermometer).
- If the connector does not fit your meter, you can remove the provided connector and attach a connector that fits your meter.

## Over Heat Alarm Testing

### Method

The Over Heat alarm test panel is located on the back panel of the Model 505 (see Figure 5).

1. Insert the open hose end from the warming unit in the port on the temperature test device (see Figure 6).

**NOTE:** Do not block the rear air vents on the test device.

**Figure 5. Location of Over Heat Alarm Test Panel**

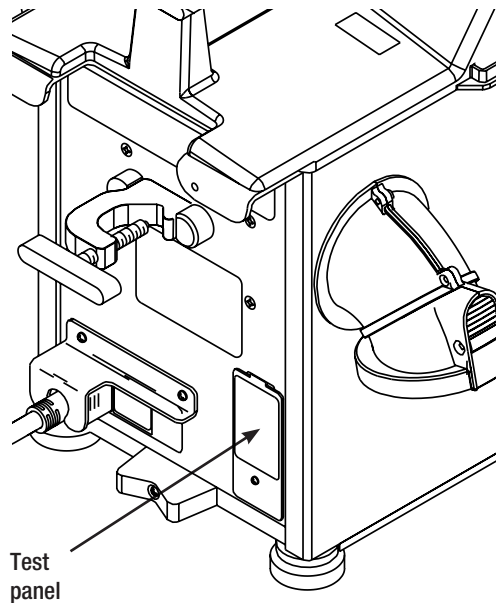

**Figure 6. Model 22110 Temperature Test Unit**

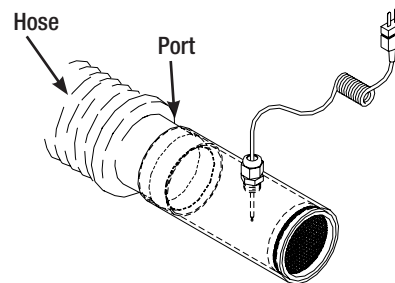

2. Connect the warming unit to the power source and turn the warming unit power ON.  
**NOTE:** The temperature setting will not affect the Over Heat test.
3. Using the Phillips-head screwdriver, remove the screw on the alarm test panel. The unit will go into an over heat condition when the test panel is loose.
4. When the over heat alarm activates both visually and audibly, note the maximum temperature achieved. Let the alarm operate for at least 1 minute or until the temperature read-out is approximately 38°C (100°F), then turn the warming unit OFF and then ON; the alarm should also turn off. The alarm and manual reset constitutes one cycle.

**NOTE:** If the alarm does not turn off, allow the unit to alarm for 1 more minute before turning the warming unit to STANDBY, then ON again.

## Over Heat Alarm Testing

5. Allow the warming unit to cycle 2 times more after the first satisfactory reading. When the alarm activates, note the alarm temperature read-out. See Table 1 for specified limits.  
*NOTE: The first over heat cycle temperature may be slightly higher when started from a cold start.*
6. If the results of the test **did not** meet specified limits, adjust the over heat thermostat. See the *Over Heat Alarm Thermostat Adjustment* section.
7. If the results of the test **did** meet specified limits, turn the warming unit to STANDBY, and disconnect the warming unit from the power source.
8. Remove the hose end from the port on the temperature test device.
9. Retighten the screw on the over heat alarm test panel.
10. Record the maintenance action taken and hours of operation (read from the hour meter) in the *Maintenance Log* section.

### Table 1. Over Heat Specification

#### Model 500 Series High Temperature Thermostat

The thermostat interrupts power to the heater and activates the alarm at a preset high temperature of  $53^{\circ} \pm 3^{\circ}\text{C}$  ( $127.4^{\circ} \pm 5.4^{\circ}\text{F}$ ) or less at the end of the hose, as determined by the Model 221 Temperature Test Kit or the Model 22110 Temperature Test Unit.

## Over Heat Alarm Thermostat Adjustment



**WARNING:** Improper adjustment of the warming unit's over heat alarm setpoint could result in patient exposure to temperatures outside of the indicated range, and may lead to patient injury.

- Closely follow instructions for thermostat adjustment.



- Dangerous voltages are present at the terminals of the thermostat.
- Always use a Model 221 Temperature Test Kit or a Model 22110 Temperature Test Unit to verify output temperatures.
- Recalibrate the temperature test kit at least once a year. The Model 22110 Temperature Test Unit does not need to be calibrated. The meter it is connected to must be calibrated. Follow the calibration instructions in the meter service manual or follow standard facility calibration schedules.
- When in doubt, contact Arizant Healthcare Technical Support for assistance in temperature adjustment.

### Tools/Equipment

---

- Model 221 Temperature Test Kit or a Model 22110 Temperature Test Unit
- Small slotted screwdriver
- Phillips-head screwdriver

### Method

---

1. Insert the open hose end from the warming unit in the port on the temperature test device.  
**NOTE:** Do not block the rear air vents on the test device.
2. Connect the warming unit to the power source and turn the warming unit power ON.  
**NOTE:** The temperature setting will not affect the over heat adjustment.
3. Using the Phillips-head screwdriver, remove the screw on the alarm test panel. Lift and remove the panel.



### Over Heat Alarm Thermostat Adjustment

4. Locate the over heat adjustment thermostat (see Figure 7).  
*NOTE: Adjustment of the over heat alarm thermostat is most easily done while the temperature read-out is climbing.*
5. Use a small slotted screwdriver to adjust the thermostat.
  - If the tested alarm temperature was **below** the specified limits, turn the screwdriver **CLOCKWISE** to increase the alarm temperature.
  - If the tested alarm temperature was **above** specified limits, turn the screwdriver **COUNTERCLOCKWISE** to lower the alarm temperature.
6. Fine-tune the adjustment until the warming unit alarms at the specified temperature.
7. Manually turn the warming unit to **STANDBY**, then **ON** again. This manual reset constitutes one cycle.
8. Retest the alarm temperature to verify correct adjustment at least 2 times. Allow the warming unit to cycle before each test.
9. When the warming unit alarm setting is within the specified limit, turn the warming unit to **STANDBY** and disconnect it from the power source.
10. Remove the hose end from the temperature test device.
11. Replace the over heat alarm test panel. Resecure the screw.
12. Record the maintenance action taken and the hours of operation (read from the hour meter) in the *Maintenance Log* section.

Figure 7. Location of Over Heat Alarm Thermostat

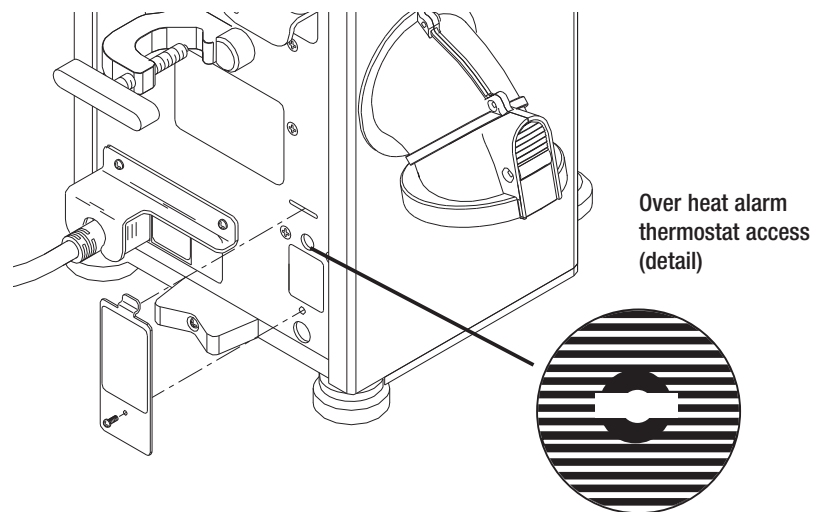

## Normal Operating Temperature Testing



**WARNING:** Perform all testing and adjustments of warming unit temperature with a calibrated Model 221 Temperature Test Kit or a Model 22110 Temperature Test Unit. Arizant Healthcare Inc. assumes no responsibility for the reliability, safety, or performance of the Bair Hugger system if warming unit temperature testing or adjustments are made in any other manner than that described here. Improper measurement or adjustment of the warming unit's normal operating temperature could result in patient exposure to temperatures outside of the indicated range, and may lead to patient injury.

### Service Frequency

6-month intervals, or 500 hours of use

### Tools/Equipment

Model 221 Temperature Test Kit or Model 22110 Temperature Test Unit

### Method

1. Insert the open hose end from the warming unit in the port on the temperature test device (see Figure 6).

**NOTE:** Do not block the rear air vents on the test device.

2. Turn the warming unit power ON and select the HIGH temperature setting. Always begin testing at the HIGH setting.
3. Note the ambient room temperature.
4. After approximately 5 minutes of operation, note the temperature read-out. Use Figure 8 to correlate ambient temperature to the warming unit's operating temperature.

**Figure 8. Room Temperature vs. High Temperature Output**

Warming unit temperature setting should be on HIGH when conducting this test

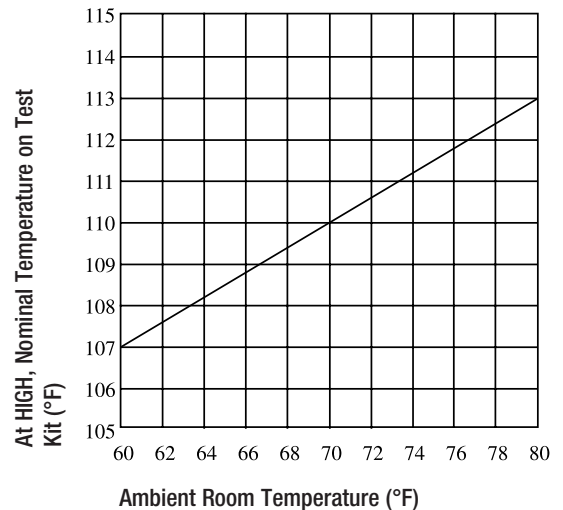
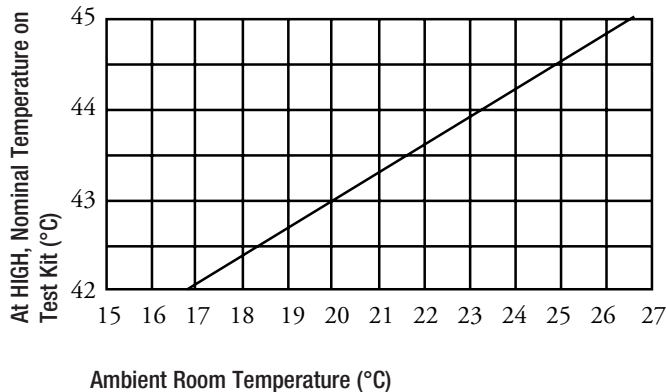

### **Normal Operating Temperature Testing**

5. After correcting for ambient temperature, the tested normal operating temperature should meet the limits specified in Table 2.
6. If the HIGH temperature setting is not within specified limits, adjust the normal operating temperature. See the *Normal Operating Temperature Adjustment* section.
7. If the HIGH temperature setting is within specified limits, verify the MED and then LOW settings against specified limits (allow the warming unit to operate at each temperature setting for about 3 to 5 minutes before test).
8. Turn the warming unit to STANDBY. Remove the hose end from the port on the temperature test device.
9. Record the maintenance action taken and the hours of operation (read from the hour meter) in the *Maintenance Log* section.

**Table 2. Model 500 Series Operating Temperatures**

*(Operating temperature = Average temperature at the end of the hose.)*

HIGH: 43° ± 3°C (109.4° ± 5.4°F)

MED: 38° ± 3°C (100.4° ± 5.4°F)

LOW: 32° ± 3°C (89.6° ± 5.4°F)

Note: Air temperature reaching the patient is approximately 2°C lower than the listed temperatures.

## Normal Operating Temperature Adjustment



**WARNING:** *Improper adjustment of the warming unit's normal operating temperature could result in patient exposure to temperatures outside of the indicated range, and may lead to patient injury.*

- *Closely follow instructions for temperature adjustment.*
- *Always use a Model 221 Temperature Test Kit or a Model 22110 Temperature Test Unit to verify output temperatures.*
- *Always make adjustments relative to the HIGH temperature setting on the warming unit. When the HIGH setting is accurately adjusted, the MED and LOW settings should also be within specified limits. If the HIGH range is properly set, and MED and/or LOW do not meet specs, call Technical Service.*
- *Recalibrate the temperature test kit at least once a year. The Model 22110 Temperature Test Unit does not need to be calibrated. The meter it is connected to must be calibrated. Follow the calibration instructions in the meter service manual or follow standard facility calibration schedules.*
- *When in doubt, contact Technical Service for assistance in temperature adjustment.*

### Tools/Equipment

---

Model 221 Temperature Test Kit or  
Model 22110 Temperature Test Unit  
Small slotted screwdriver

### Method

---

The operating temperature adjustment potentiometer may be accessed through openings in the upper right corner of the rear access panel (see Figure 9).

1. Insert the open hose end from the warming unit in the port on the temperature test device.  
**NOTE:** *Do not block the rear air vents on the test device.*
2. Turn the warming unit power ON, and allow it to operate at HIGH for about 3 to 5 minutes before adjusting the potentiometer.

### Normal Operating Temperature Adjustment

3. Insert the slotted screwdriver in the potentiometer access hole. You must access the potentiometer blindly, so carefully move the screwdriver until it fits into the slot of the potentiometer.
  - If the tested operating temperature was **below** specified limits, turn the screwdriver **CLOCKWISE** to increase the operating temperature.
  - If the tested operating temperature was **above** specified limits, turn the screwdriver **COUNTERCLOCKWISE** to lower the operating temperature.
4. Adjust the potentiometer until the temperature read-out meets the limits specified in Table 4 for the HIGH temperature setting (correlated to ambient temperature as in Figure 8).
5. Verify that the MED and then LOW temperature settings are also within specified limits. If the HIGH range is properly set, and MED and/or LOW do not meet specs, call Technical Service.
6. Turn the warming unit power OFF and remove the hose from the port on the temperature test device.
7. Record the maintenance action taken and hours of operation (read from the hour meter) in the *Maintenance Log* section.

Figure 9. Location of Operating Temperature Adjustment Potentiometer

Operating temperature potentiometer access

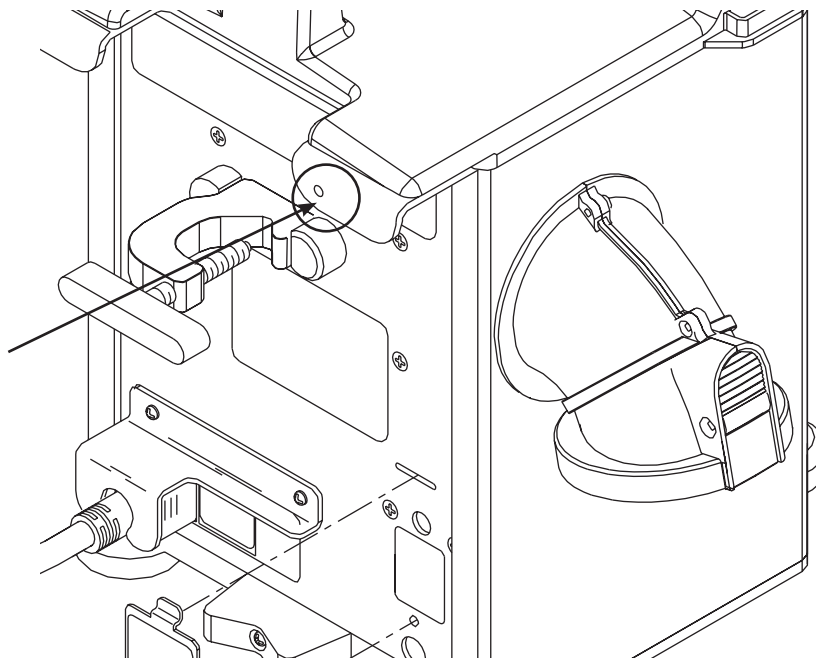

# Specifications

---

## Physical Characteristics

**Dimensions** 13 in. high x 10 in. deep x 11 in. wide  
(33 cm high x 25 cm deep x  
28 cm wide)

**Weight** 11.5 lb (5.2 kg)

## Safety System

### Thermostat

---

Bulb and capillary type

### Over Heat Warning

---

If the temperature gets too high, the Over Heat warning light on the front panel will illuminate and the alarm will sound. The heat will shut off and the blower will continue to run.

### High Temperature Thermostat

---

The thermostat interrupts power to the heater and activates the alarm at a preset high temperature of  $53^{\circ} \pm 3^{\circ}\text{C}$  ( $127.4^{\circ} \pm 5.4^{\circ}\text{F}$ ) or less at the end of the hose, as determined by the Model 221 Temperature Test Kit or Model 22110 Temperature Test Unit.

## Temperature Characteristics

Air temperatures reaching the patient are approximately  $2^{\circ}\text{C}$  lower than the listed temperatures.

### Operating Temperatures

---

Average temperature at the end of the hose:

HIGH:	$43^{\circ} \pm 3^{\circ}\text{C}$	$(109.4^{\circ} \pm 5.4^{\circ}\text{F})$
MED:	$38^{\circ} \pm 3^{\circ}\text{C}$	$(100.4^{\circ} \pm 5.4^{\circ}\text{F})$
LOW:	$32^{\circ} \pm 3^{\circ}\text{C}$	$(89.6^{\circ} \pm 5.4^{\circ}\text{F})$

## Electrical Characteristics

### Leakage Current

---

Meets regulatory standards for leakage current.

### Motor

---

Fractional horsepower, single phase

### Heater

---

An electric heating element

### Fuses

---

10A, 200mA (110-120 VAC Units)

6.3A, 100mA (220-240 VAC Units)

10, 160mA (100 VAC Units)

### Device Ratings

---

110-120 VAC, 60 Hz, 10 Amperes

220-240 VAC, 50 Hz, 4.5 Amperes

100 VAC, 50/60 Hz, 10 Amperes

## Key to Figure 10

---

- 1 Bulb Type Thermostat
- 2 Hour Meter
- 3 Control Board
- 4 Thermocouple
- 5 Cabinet
- 6 Top Cover
- 7 Base
- 8 Filter, 0.2 Micron
- 9 V- Bumper
- 10 Heater Housing
- 11 Motor 115V, 60Hz
- 12 Heater 120V
- 14 Handle
- 15 Top Warning Label
- 16 Control Board Fuse 200mA
- 17 Overtemp Switch
- 18 Electrical Shield
- 19 Control Panel Label
- 20 Back Plate
- 21 Power Entry Module
- 22 Power Fuses (2)
- 23 Filter Bracket
- 24 Elbow Assembly
- 25 Hose Assembly

Figure 10. Exploded Drawing

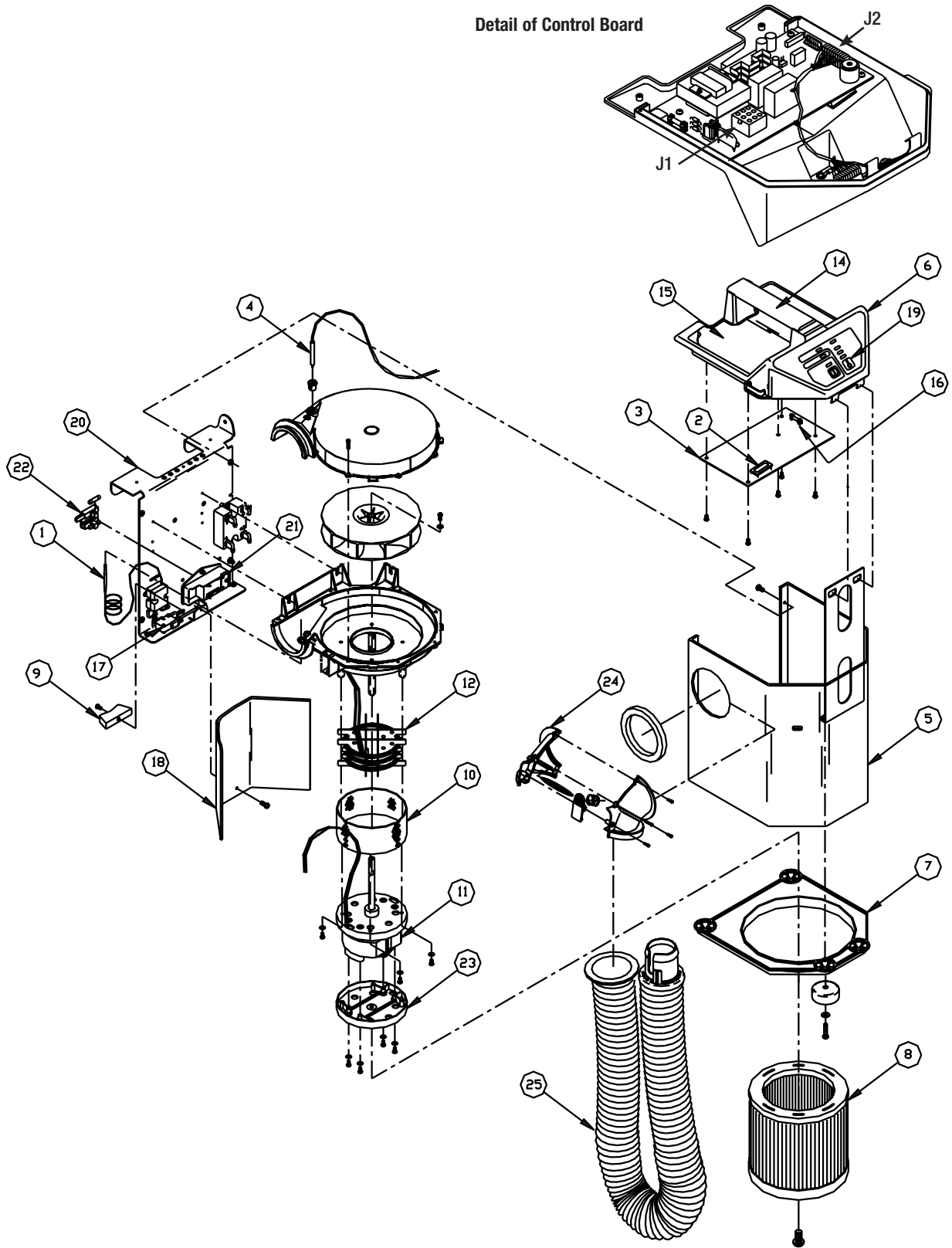



## Technical Support and Customer Service

---

### United States, Worldwide

Technical Service TEL: 1-952-947-1200  
1-800-733-7775  
Order Placement TEL: 1-952-947-1200  
1-800-733-7775  
FAX: 1-952-947-1400

### Within Europe

Technical Service TEL: +49-4154-9934-0  
FAX: +49-4154-9934-20  
Toll-free in Germany 0800-100-1236  
Order Placement (USA) FAX: +1-952-947-1400

### When You Call for Technical Support

We will need to know the serial number of your Bair Hugger unit when you call us. On Model 505 units, the serial number label is affixed to the rear panel.

### In-Warranty Repair and Exchange USA

Replacement parts to correct a problem are delivered at no charge. To return a device to Arizant Healthcare Inc. for service, first obtain a Return Authorization (RA) number from a technical service representative. Please use this number on all correspondence when returning a device for service. A shipping carton will be delivered to you at no charge, if needed. We will service and ship your device within five (5) working days of our receipt. Call your local supplier or sales representative to inquire about loaner devices while your device is being serviced.

### Worldwide

Contact your local distributor concerning in-warranty repair and exchange.

## Returning Units for Service

### Tools/Equipment

---

- Arizant Healthcare\* service carton
- Tape dispenser
- Shipping label
- Marking pen

### Method

---

1. Call Technical Support (see inside front cover for phone number) to get a Return Authorization (RA) number and a service carton.
2. Open the carton and remove the upper foam pad. Leave the lower foam pad in place in the bottom of the carton.
3. Rotate the hose elbow toward the back of the unit, and carefully lower the unit into the carton. Place the hose as shown in Figure 11.
4. Insert the upper foam pad (see Figure 11).
5. Seal the carton with tape.
6. Apply the shipping label addressed to Arizant Healthcare Inc.
7. Using the marking pen, write your RA number (from Technical Support) on the outside of the carton.

**Figure 11. Service Carton**

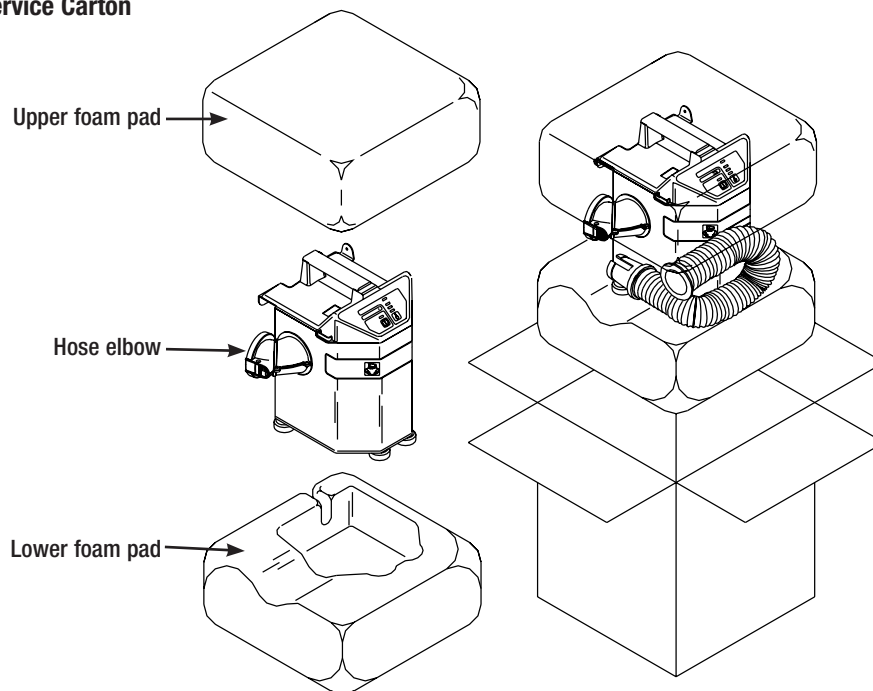

# Troubleshooting

## Call Technical Support for Replacement Parts

Problem	Possible Cause	Remedy; Service Procedure
The warming unit does not turn on.	<p>Damaged or unplugged power cord.</p> <p>Blown power fuses</p> <p>Poor or loose wire connections.</p> <p>No power to outlet.</p> <p>Loose cord at power entry cord.</p>	<p>Replace the cord or plug in the warming unit.</p> <p>Replace the blown fuses. See <i>Power Fuse Replacement</i> procedure.</p> <p>Check the connectors at the power entry module.</p> <p>Ensure that connector J1 is firmly seated (see Figure 10).</p> <p>Check power at the outlet.</p> <p>Firmly seat the power module.</p>
The warming unit circulates air but it does not heat.	Poor connections of the thermocouple (J2) on the control board. (See Figure 10.)	Reattach any loose thermocouple leads connections.
The warming unit heats at some temperature settings but not on others. Example: the warming unit works on LOW setting, but not on HIGH setting.	<p>Loose connection at J2. (See Figure 10)</p> <p>Warming unit has been in an over heat condition and temperature has decreased.</p> <p>Loose wire connections at the desired heat setting.</p>	<p>Reattach loose connections.</p> <p>Turn the warming unit OFF and then back ON.</p> <p>Reattach any loose connections.</p>
Warming unit alarms upon startup.	<p>Open thermostat.</p> <p>Poor wire connections at thermostat.</p>	<p>Call Technical Service.</p> <p>Reattach any loose connections to thermostat. (See Figure 10).</p>
Warming unit alarms at too lower too high a temperature.	Over heat thermostat not in calibration.	See <i>Over Heat Alarm Thermostat Adjustment</i> procedure.

# Maintenance Log

Date	Maintenance Action Performed	Hour Meter

<b>Maintenance Log</b>		
<b>Date</b>	<b>Maintenance Action Performed</b>	<b>Hour Meter</b>

















## Maintenance Log

Date	Maintenance Action Performed	Hour Meter

# Symbol Definitions

---

	ON/STANDBY
	ON (used on isolation switch)
	OFF (used on isolation switch)
	ON/OFF push button switch
	Temperature Control
	Equipotentiality plug (Ground)
	Fuse
	Attention (see appropriate documents)
	Dangerous Voltage
	Type BF Equipment (patient applied)
	Voltage, Alternating Current (AC)
	Special Refuse, discard separately
	Protective earth ground
	No free hosing