

**Konica**

**SERVICE MANUAL**

**Models**  
**DB-209/210/409/410**

MARCH 2001  
CSM-DB209/210

**KONICA BUSINESS TECHNOLOGIES, INC.**



# **DB-209/210/409/410 SERVICE MANUAL**

**MARCH 2001**

**Used on Konica Models  
7020, 7025, 7030, and 7035**

## **IMPORTANT NOTICE**

Because of the possible hazards to an inexperienced person servicing this equipment, as well as the risk of damage to the equipment, Konica Business Technologies strongly recommends that all servicing be performed by Konica-trained service technicians only.

Changes may have been made to this equipment to improve its performance after this service manual was printed. Accordingly, Konica Business Technologies, Inc., makes no representations or warranties, either expressed or implied, that the information contained in this service manual is complete or accurate. It is understood that the user of this manual must assume all risks or personal injury and/or damage to the equipment while servicing the equipment for which this service manual is intended.

Corporate Publications Department

# CONTENTS

## DB-209/210

### 1. OUTLINE

DB-209/210 PRODUCT SPECIFICATIONS .....	1
[1] Type .....	1
[2] Functions .....	1
[3] Machine data .....	1
[4] Maintenance .....	1
[5] Machine environment .....	1
CENTER CROSS SECTION .....	2
DRIVE SYSTEM DIAGRAM .....	3

### 2. UNIT EXPLANATION

PAPER FEED SECTION .....	4
[1] Composition .....	4
[2] Mechanisms .....	4
[3] Paper feed and no paper detection control .....	5
[4] Tray up and down control .....	7
[5] Paper size detection control .....	8
[6] Control of paper-level detection .....	9
[7] Jam detection control .....	9

### 3. DISASSEMBLY/ASSEMBLY

DISASSEMBLY/ASSEMBLY .....	10
[1] Removing and reinstalling paper feed tray .....	10
[2] Removing and reinstalling the paper feed unit .....	10
[3] Replacing the feed roller rubber and double feed prevention rubber/upper .....	11
[4] Replacing the double feed prevention rubber/lower .....	12

## DB-409/410

### 1. OUTLINE

DB-409/410 PRODUCT SPECIFICATIONS .....	13
[1] Type .....	13
[2] Functions .....	13
[3] Machine data .....	13
[4] Maintenance .....	13
[5] Machine environment .....	13
CENTER CROSS SECTION .....	14
DRIVE SYSTEM DIAGRAM .....	15

### 2. UNIT EXPLANATION

PAPER FEED SECTION .....	16
[1] Composition .....	16
[2] Mechanisms .....	16
[3] Paper feed and no paper detection control .....	17
[4] Tray up and down control .....	18
[5] Paper size detection control .....	19
[6] Control of paper-level detection .....	20

### 3. DISASSEMBLY/ASSEMBLY

DISASSEMBLY/ASSEMBLY .....	21
[1] Removing and reinstalling the paper feed tray .....	21
[2] Removing and reinstalling the paper feed unit .....	21
[3] Replacing the feed roller rubber and double feed prevention rubber/upper .....	22
[4] Replacing the double feed prevention rubber/lower .....	23
[5] Replacing the wires .....	24

### 4. DB-209/210/409/410 DIAGRAMS

DB-209/210 ELECTRICAL PARTS LAYOUT .....	27
DB-409/410 ELECTRICAL PARTS LAYOUT .....	28
DB-209/210 CONNECTOR LAYOUT .....	29
DB-409/410 CONNECTOR LAYOUT .....	30
DB-209/DB-409 TIMING CHART (8.5X11, LIFE SIZE, 3 COPIES, FEED FROM TRAY3 .....	31
DB-209/210/409/410 OVERALL WIRING DIAGRAM ....	33

Blank

# SAFETY PRECAUTIONS

## Installation Environment

Safety considerations usually are directed toward machine design and the possibility of human error. In addition, the environment in which a machine is operated must not be overlooked as a potential safety hazard.

Most electrical equipment is safe when installed in a normal environment. However, if the environment is different from what most people consider to be normal, it is conceivable that the combination of the machine and the room air could present a hazardous combination. This is because heat (such as from fusing units) and electrical arcs (which can occur inside switches) have the ability to ignite flammable substances, including air.

**When installing a machine, check to see if there is anything nearby which suggests that a potential hazard might exist.** For example, a laboratory might use organic compounds which, when they evaporate, make the room air volatile. Potentially dangerous conditions might be seen or smelled. *The presence of substances such as cleaners, paint thinners, gasoline, alcohol, solvents, explosives, or similar items should be cause for concern.*

If conditions such as these exist, take appropriate action, such as one of the following suggestions.

- Determine that the environment is controlled (such as through the use of an exhaust hood) so that an offending substance or its fumes cannot reach the machine.
- Remove the offending substance.
- Install the machine in a different location.

The specific remedy will vary from site to site, but the principles remain the same. To avoid the risk of injury or damage, be alert for changes in the environment when performing subsequent service on any machine, and take appropriate action.

## Unauthorized Modifications

Konica copiers have gained a reputation for being reliable products. This has been attained by a combination of outstanding design and a knowledgeable service force.

The design of the copier is extremely important. It is the design process that determines tolerances and *safety margins* for mechanical, electrical, and electronic aspects. It is not reasonable to expect individuals not involved in product engineering to know what

effect may be caused by altering any aspect of the machine's design. Such changes have the potential of degrading product performance and reducing safety margins.

For these reasons, *installation of any modification not specifically authorized by Konica Business Machines U.S.A., Inc., is strictly prohibited.*

The following list of prohibited actions is not all-inclusive, but demonstrates the intent of this policy.

- Using an extension cord or any unauthorized power cord adapter.
- Installing any fuse whose rating and physical size differs from that originally installed.
- Using wire, paper clips, solder, etc., to replace or eliminate any fuse (including temperature fuses).
- Removing (except for replacement) any air filter.
- Defeating the operation of relays by any means (such as wedging paper between contacts).
- Causing the machine to operate in a fashion other than as it was designed.
- Making any change which might have a chance of defeating built-in safety features.
- Using any unspecified replacement parts.

## General Safety Guidelines

This copier has been examined in accordance with the laws pertaining to various product safety regulations prior to leaving the manufacturing facility to protect the operators and service personnel from injury. However, as with any operating device, components will break down through the wear-and-tear of everyday use, as will additional safety discrepancies be discovered. For this reason, it is important that the technician periodically performs safety checks on the copier to maintain optimum reliability and safety.

The following checks, not all-inclusive, should be made during each service call:

**CAUTION:** Avoid injury. Ensure that the copier is disconnected from its power source before continuing.

- Look for sharp edges, burrs, and damage on all external covers and copier frame.
- Inspect all cover hinges for wear (loose or broken).
- Inspect cables for wear, frays, or pinched areas.

- Ensure that the power cord insulation is not damaged (no exposed electrical conductors).
- Ensure that the power cord is properly mounted to the frame by cord clamps.
- Check the continuity from the round lug (GND) of the power cord to the frame of the copier – ensure continuity. An improperly grounded machine can cause an electrically-charged machine frame.

### **Safeguards During Service Calls**

Confirm that all screws, parts, and wiring which are removed during maintenance are installed in their original positions.

- When disconnecting connectors, do not pull the wiring, particularly on AC line wiring and high voltage parts.
- Do not route the power cord where it is likely to be stepped on or crushed.
- Carefully remove all toner and dirt adhering to any electrical units or electrodes.
- After part replacement or repair work, route the wiring in such a way that it does not contact any burrs or sharp edges.
- Do not make any adjustments outside of the specified range.

### **Applying Isopropyl Alcohol**

Care should be exercised when using isopropyl alcohol, due to its flammability. When using alcohol to clean parts, observe the following precautions:

- Remove power from the equipment.
- Use alcohol in small quantities to avoid spillage or puddling. Any spillage should be cleaned up with rags and disposed of properly.
- Be sure that there is adequate ventilation.
- Allow a surface which has been in contact with alcohol to dry for a few minutes to ensure that the alcohol has evaporated completely before applying power or installing covers.

### **Summary**

It is the responsibility of every technician to use professional skills when servicing Konica products. There are no short cuts to high-quality service. Each copier must be thoroughly inspected with respect to safety considerations as part of every routine service call. The operability of the copier, and more importantly, the safety of those who operate or service the copier, are directly dependent upon the conscientious effort of each and every technician.

Remember...when performing service calls, use good judgement (have a watchful eye) to identify safety hazards or potential safety hazards that may be present, and correct these problem areas as they are identified -- the safety of those who operate the copier as well as those who service the copier depend on it!



# DB-209/210 PRODUCT SPECIFICATIONS

## [1] Type

**Type:** Tray paper feed  
(Front loading)

## [2] Functions

**Paper size:**

U.S.A.	Europe and others
11 × 17, 8.5 × 14, 8.5 × 11R, 8.5 × 11, 5.5 × 8.5, F4, A3, A4R, A4, A5R	A3, B4, A4, A4R, B5, A5R, 11 × 17, 8.5 × 11, 8.5 × 11R, F4

**Paper type:** 16 lb. to 24 lb. high quality paper

**Maximum Paper capacity:** 500 sheets x 2 trays  
(22 lb.)

## [3] Machine data

**Power:** DC24V/5V (supplied from main body)

**Power consumption:** Max.40VA (When the PTC heater is not in use.)

**Weight:** Approximately 56 lb.

**Machine Dimensions:** Length 22.8 in.  
Depth 23.4 in.  
Height 12.2 in.

## [4] Maintenance

**Maintenance:** Same as main body

## [5] Machine operation environment

**Temperature:** 50 to 86°F

**Humidity:** 20 to 80%RH

**Note :** Specifications are subject to change without notice.

# CENTER CROSS SECTION

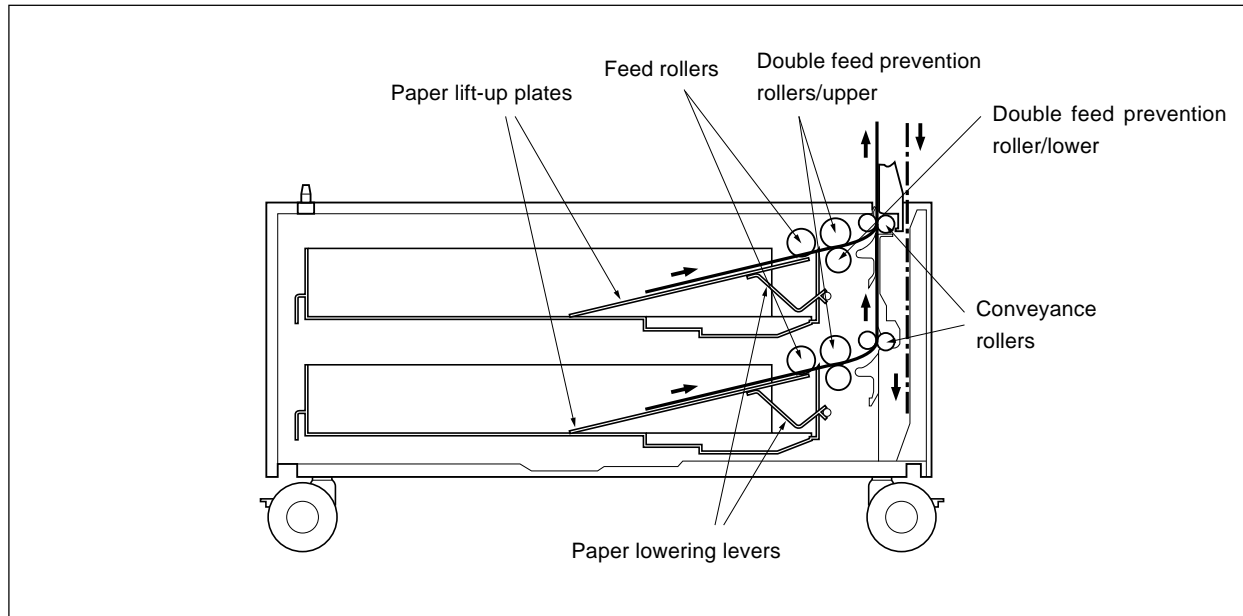

# DRIVE SYSTEM DIAGRAM

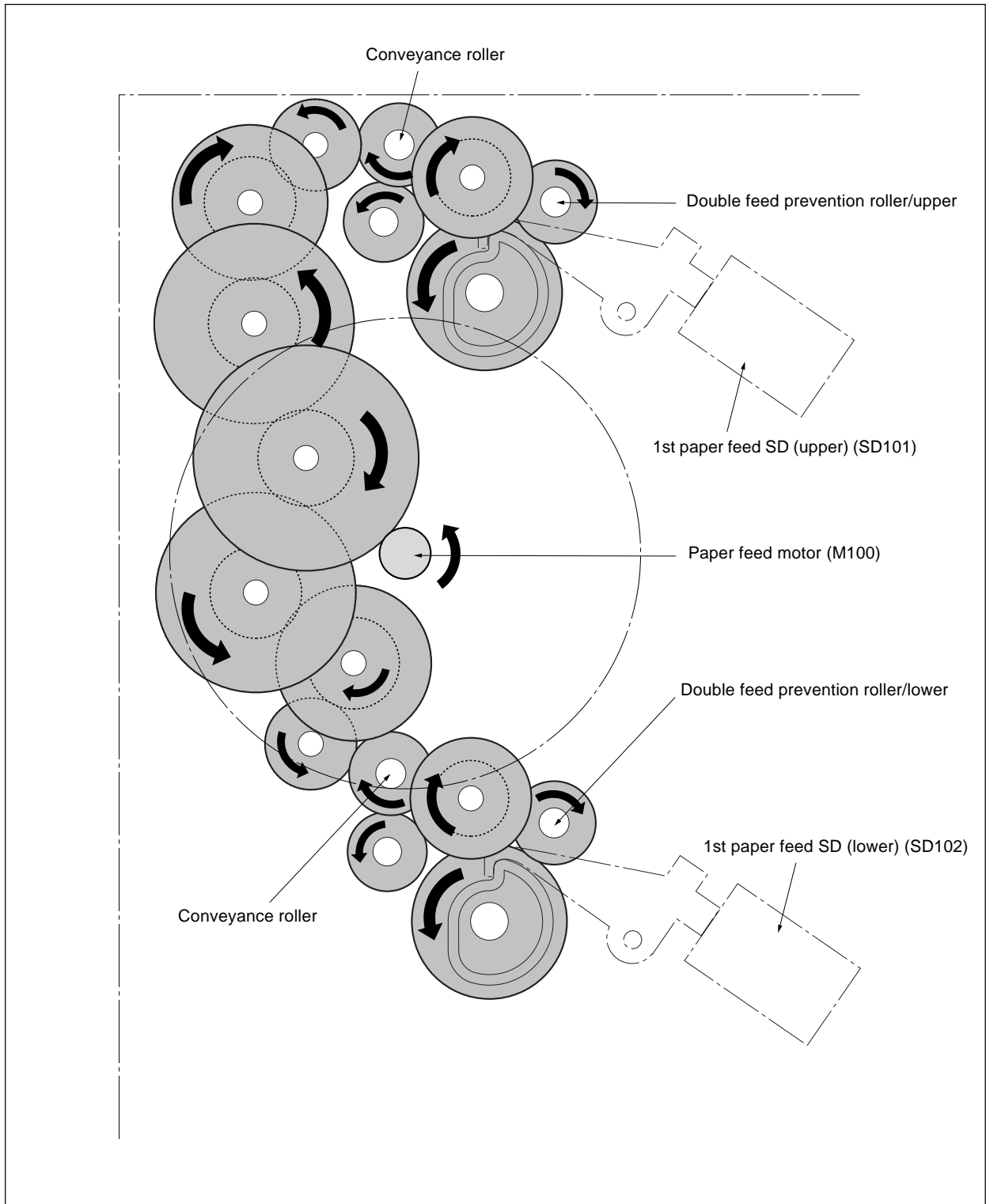

# PAPER FEED UNIT

## [1] Composition

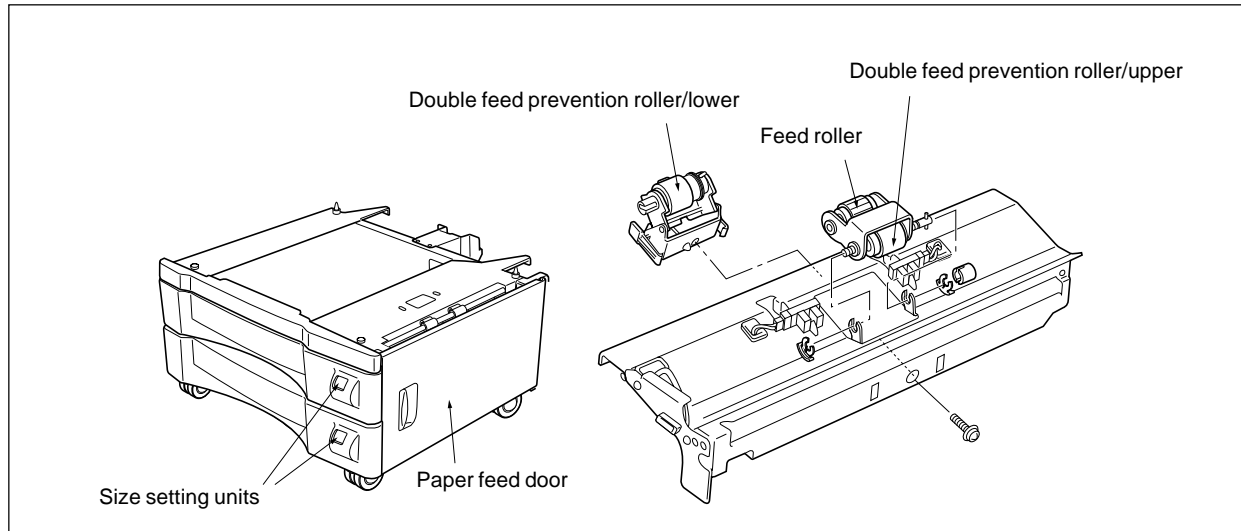

## [2] Mechanisms

Mechanism	Method
Paper feed	Paper feed roller
Paper lifting	Paper lift-up plate
Double feed prevention	Torque limiter
Tray loading	Front loading
1st paper feed	Paper feed SD Feed roller
Jam processing	Release of pressure on double feed prevention roller
No paper detect	Photosensor
Paper size detect	Size setting unit
Paper conveyance	Roller conveyance
Conveyance drive	Gears

### [3] Paper feed and no paper detection control

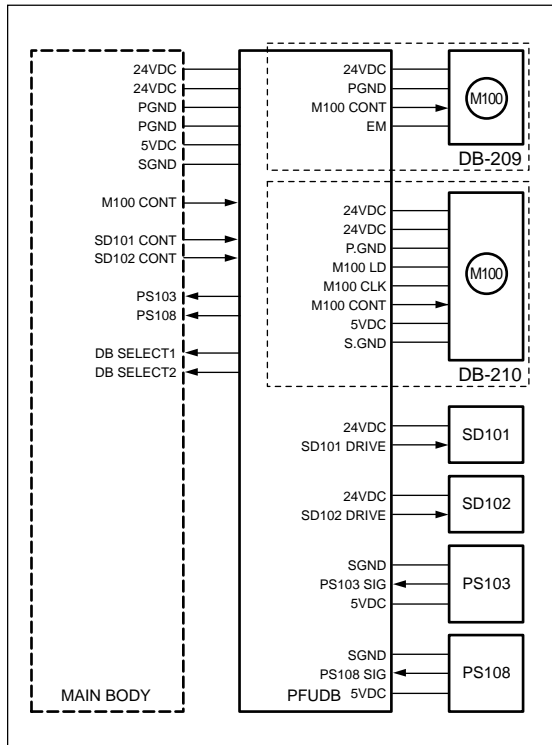

Paper feed is carried out by transmitting the drive of the M100 (Paper feed motor) to the upper and lower paper feed rollers and to the feed rollers. When feed starts, SD101 (1st. paper feed SD (upper)) or SD102 (1st. paper feed SD (lower)) raises and lowers the feed roller and contacts the paper.

Drive of the M100, SD101 and SD102 is carried out by PFUDB (PFU drive board) and controlled by the main body.

No paper detection is carried out with PS103 (No paper detect PS (upper)) and PS108 (No paper detect PS (lower)) and controlled by the main body via the PFUDB.

#### 1. Operation

##### a. Paper feed operation timing (upper tray)

- (1) 1st. sheet start  
A specified time after start-button is turned ON
- (2) 2nd. sheet start  
A specified time after 1st. sheet SD101 is turned ON
- (3) OFF timing  
A specified time after SD101 is turned ON

##### b. Paper feed operation timing (lower tray)

- (1) 1st. sheet start  
A specified time after start-button is turned ON
- (2) 2nd. sheet start  
A specified time after 1st. sheet SD102 is turned ON
- (3) OFF timing  
A specified time after SD102 is turned ON

##### c. No paper detection

If paper in the tray is used up, PS103 or PS 108 goes OFF and the no paper detection signal of each tray is sent to the main body via the PFUDB.

**2. Signals**

**a. Input signals**

- (1) PS103 SIG (PS103 -> PFUDB)  
Upper tray paper/no paper detection signal  
[H] :no paper  
[L] : with paper
- (2) PS108 SIG (PS108 -> PFUDB)  
Lower tray paper/no paper detection signal  
[H] :no paper  
[L] : with paper
- (3) SD101 CONT (MAIN BODY -> PFUDB)  
SD101 ON/OFF control signal from main body  
[H] :OFF  
[L] : ON
- (4) SD102 CONT (MAIN BODY -> PFUDB)  
SD102 ON/OFF control signal from main body  
[H] :OFF  
[L] : ON

**b. Output signals**

- (1) M100 CONT (PFUDB -> M100)  
M100 drive control signal  
[H] :M100 OFF  
[L] :M100 ON
- (2) M100 CLK (PFUDB -> M100)  
M100 revolution control board clock signal
- (3) SD101 (PFUDB -> SD101)  
SD101 drive control signal  
[H] :OFF  
[L] : ON
- (4) SD102 DRIVE (PFUDB -> SD102)  
SD102 drive control signal  
[H] :OFF  
[L] : ON
- (5) PS103 (PFUDB -> MAIN BODY)  
Upper tray paper/no paper detection signal sent to main body
- (6) PS108 (PFUDB -> MAIN BODY)  
Lower tray paper/no paper detection signal sent to main body
- (7) DB SELECT (PFUDB -> MAIN BODY)  
DB Type identification signals sent to main body

DB	Signal	
	DB-SELECT 1	DB-SELECT 0
DB-209/210	H	L
Not connected	H	H
Undefined	L	L

## [4] Tray up and down control

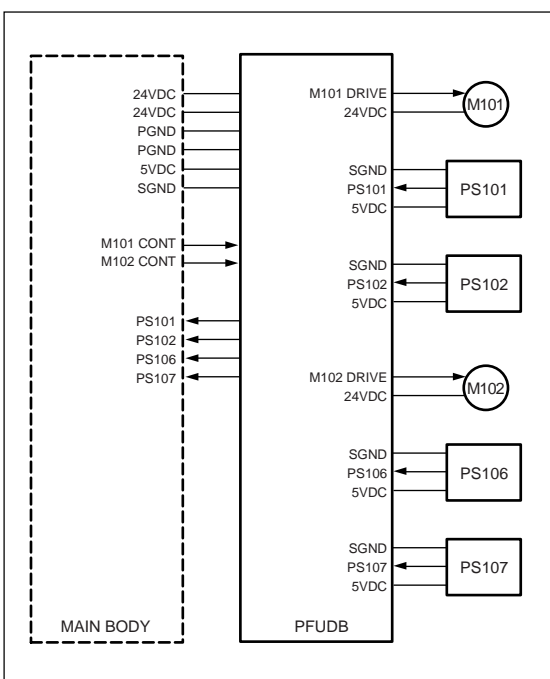

### 1. Operation

When the paper feed tray of each level is set, PS101 (Tray detect PS (upper)) and PS106 (Tray detect PS (lower)) detect the tray, M101 (Tray motor 1) and M102 (Tray motor 2) turn on and lift the base plate in the tray. When the tray is lifted, PS102 (Upper limit detect PS (upper)) and PS 107 (Upper limit detect PS (lower)) detect the paper upper limit and turn ON, M101 and M102 turn off and the raising of the tray is completed.

The down operation of the trays is performed mechanically.

### 2. Signals

#### a. Input signals

##### (1) PS101 (PS101 → PFUDB)

Upper tray detect signal

By turning ON with [L] showing, M101 raises the paper in the upper tray.

##### (2) PS106 (PS106 → PFUDB)

Lower tray detect signal

By turning on with [L] showing, M102 raises the paper in the lower tray.

##### (3) PS102 (PS102 → PFUDB)

Upper tray paper upper limit detect signal

When the upper tray is raised and arrives at the upper limit position, the signal becomes [H] and M101 is turned off.

##### (4) PS107 (PS107 → PFUDB)

Lower tray paper upper limit detect sensor

When the lower tray is raised and arrives at the upper limit position, the signal becomes [H] and M102 is turned off.

##### (5) M101 CONT (MAIN BODY → PFUDB)

M101 ON/OFF control signal from main body

##### (6) M102 CONT (MAIN BODY → PFUDB)

M102 ON/OFF control signal from main body

#### b. Output signals

##### (1) M101 DRIVE (PFUDB → M101)

M101 drive control signal

[L] : M101 ON

[H] : M101 OFF

##### (2) M102 DRIVE (PFUDB → M102)

M102 drive control signal

[L] : M102 ON

[H] : M102 OFF

##### (3) PS101 (PFUDB → MAIN BODY)

Upper tray detect signal sent to main body

##### (4) PS102 (PFUDB → MAIN BODY)

Upper tray paper upper limit detect signal sent to main body

##### (5) PS106 (PFUDB → MAIN BODY)

Lower tray detect signal sent to main body

##### (6) PS107 (PFUDB → MAIN BODY)

Lower tray paper upper limit detect signal sent to main body

**[5] Paper size detection control**

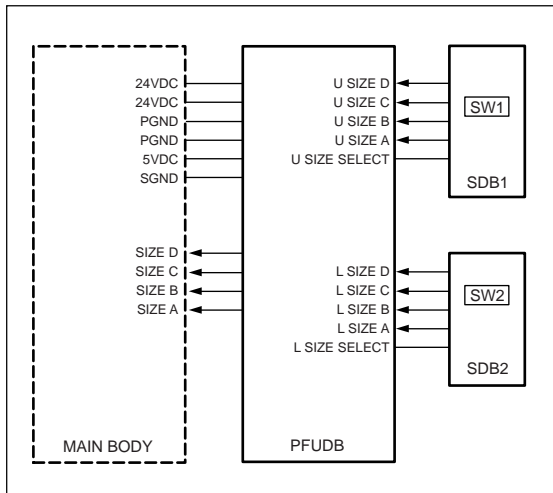

Tray paper size is detected in the main body by a signal sent from SDB1(size detection board1) and SDB2 (size detection board2) via the PFUDB (PFU drive board).

**1. Operation**

**a. Tray paper size detection**

Paper size for either tray is set by SW1 and SW2 above SDB1 and SDB2 and the PFUDB detects the switch signal corresponding to the position of SW1 and SW2.

The relation between switch signal and paper size is as follows.

**For U.S.A.**

Paper size (Label display order)	Switch signal			
	SIZE A	SIZE B	SIZE C	SIZE D
11 x 17				
A5R	○			
A4		○		
A4R	○	○		
A3			○	
F4	○		○	
5.5 x 8.5		○	○	
8.5 x 11	○	○	○	
8.5 x 11R				○
8.5 x 14	○			○

**For Europe**

Paper size (Label display order)	Switch signal			
	SIZE A	SIZE B	SIZE C	SIZE D
11 x 17				
B5	○			
B4		○		
A5R	○	○		
A4			○	
A4R	○		○	
A3		○	○	
F4	○	○	○	
11				○
11R	○			○

**2. Signals**

**a. Input signals**

- (1) U SIZE A - D (SDB1 → PFUDB)  
Upper tray paper size detect signal
- (2) U SIZE A - D (SDB2 → PFUDB)  
Lower tray paper size detect signal

**b. Output signal**

- (1) SIZE A - D (PFUDB → MAIN BODY)  
Paper size detection signal sent to main body



## [6] Control of paper-level detection

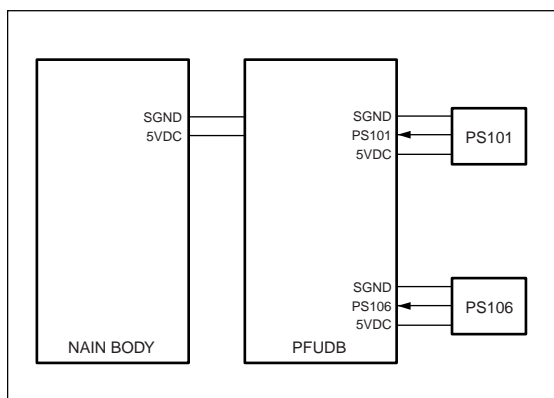

After the trays have been set in the machine, paper level is detected by PS101 (tray detect sensor PS (upper)) and PS106 (tray detect sensor PS (lower)).

As the paper level in tray runs low, the actuator at the rear part of the tray gradually rotates as illustrated below. The level is detected by the number of times the sensor goes ON/OFF (the number of slits detected).

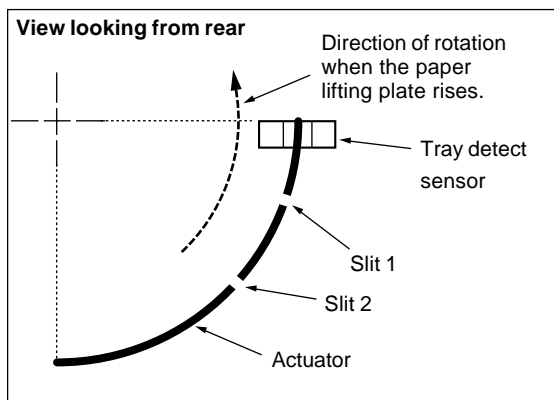

### 1. Operation

#### a. Detection of paper level in tray

The following shows the relation between the paper level and the number of slit detections by the sensor (PS101 or PS106).

0 slits : Full

1 slit : Medium

2 slits : Low

## [7] Jam detection control

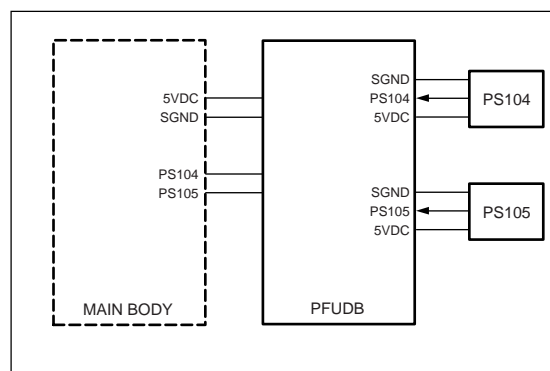

### 1. Operation

Jam detection control is performed by the main body when it has judged the changes in the PS104 (jam detect PS1) and PS105 (jam detecting PS2) detection signals. If the ON detection signal of each sensor does not change after a specified time, it is judged that there is a paper jam.

### 2. Signals

#### a. Input signals

##### (1) PS104 (PS104 → PFUDB)

Turns on when [H] is showing, and notifies the main body of the presence or absence of paper in the upper part of the DB.

##### (2) PS105 (PS105 → PFUDB)

Goes ON when the level is [H], and notifies the main body of the existence or otherwise of paper in the lower part of the DB and also of whether the paper feed door is open or closed.

#### b. Output signals

##### (1) PS104 (PFUDB → MAIN BODY)

PS104 detect signal sent to main body

##### (2) PS 105 (PFUDB → MAIN BODY)

PS105 detect signal sent to main body

# DISASSEMBLY/ASSEMBLY

⚠ Caution: Make sure the power plug is taken out of the socket.

## [1] Removing and reinstalling paper feed tray

- (1) Pull out the paper feed tray and take out the 2 set screws on the right hand side.
- (2) Remove the paper tray from the guide rails.

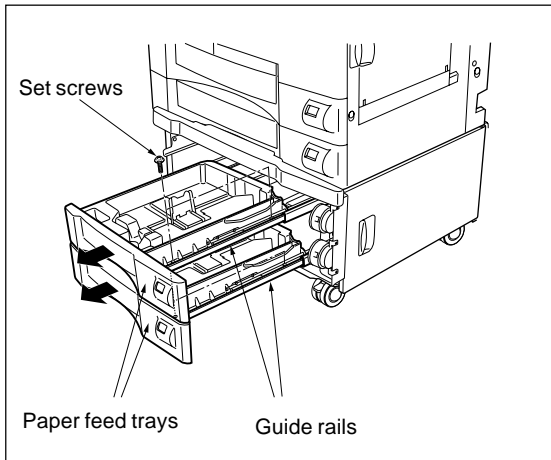

- (3) Install by reversing the removal procedure.

## [2] Removing and reinstalling the paper feed unit

- (1) Remove the tray cover and the paper tray.

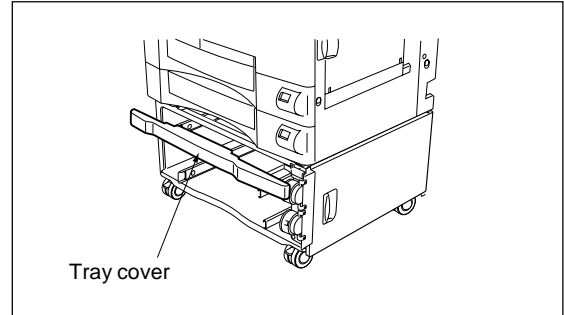

- (2) Opening the paper feed door, take out the 3 set screws and remove the size setting unit.

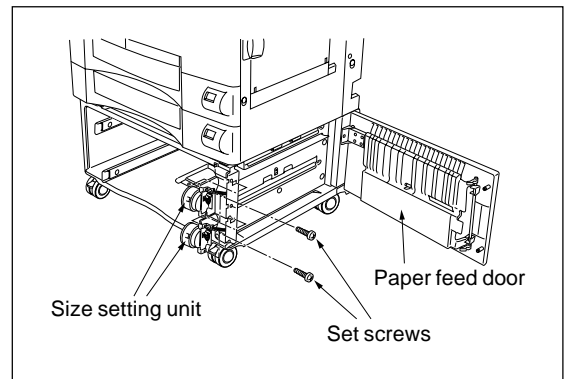

- (3) Remove the 3 set screws and remove the cover.

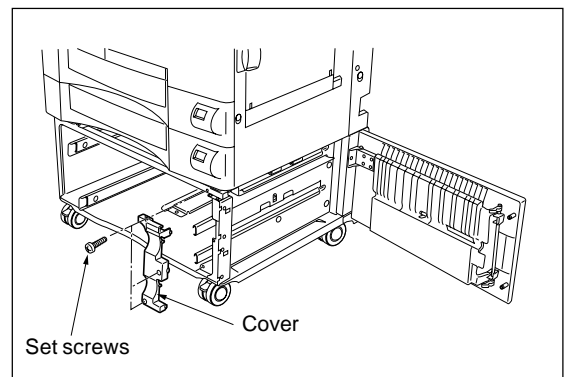

- (4) Remove the paper feed unit connector.

- (5) Remove the 2 screws indicated by the engraved arrows and remove by drawing the paper feed unit forward.

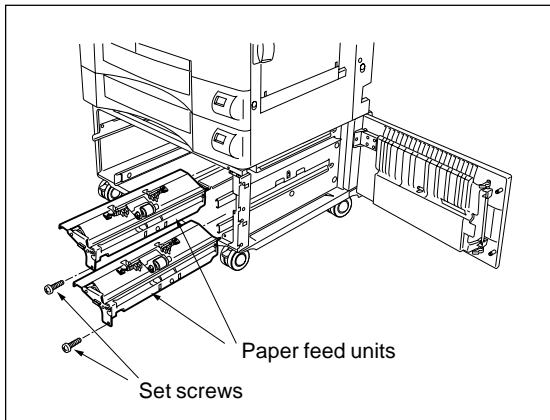

- (6) Install by reversing the removal procedure.

**Caution:** Immediately after installing the paper feed unit, as the swing gear and the paper feed solenoid are not in the correct position, it sometimes happens that paper is not fed. For this reason, always make a copy to confirm that operation is normal.

### [3] Replacing of the feed roller rubber and double feed prevention rubber/upper

- (1) Remove the paper feed unit.
- (2) Remove the fixing rings and bearings.
- (3) While withdrawing the paper feed shaft, remove the double feed prevention roller/upper from the paper feed roller unit.

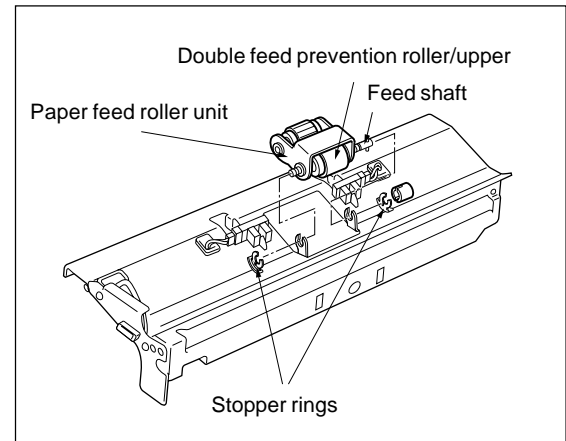

- (4) Removing the fixing ring and remove the feed roller by withdrawing the guide shaft in the direction shown by the arrow.
- (5) Remove the feed rubber from the feed roller.
- (6) Remove the feed shaft and then remove the double feed prevention roller/upper.
- (7) Remove the double feed prevention rubber/upper from the double feed prevention roller/upper.

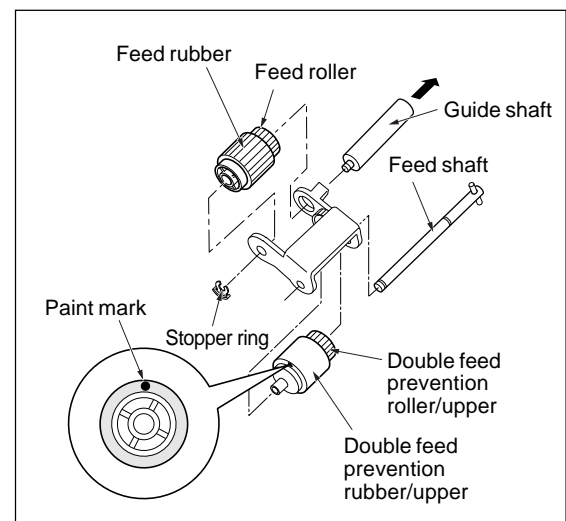

- (8) Install by reversing the removal procedure.

**Caution:** Pay attention to the direction in which you install each roller rubber. Install so that the swing-gear shaft enters the paper feed roller unit.

## [4] Replacing the double feed prevention rubber/lower

- (1) Remove the paper feed unit.
- (2) Remove the set screw.
- (3) Pushing the knobs on either side of the double feed prevention unit, then remove by drawing it forward.

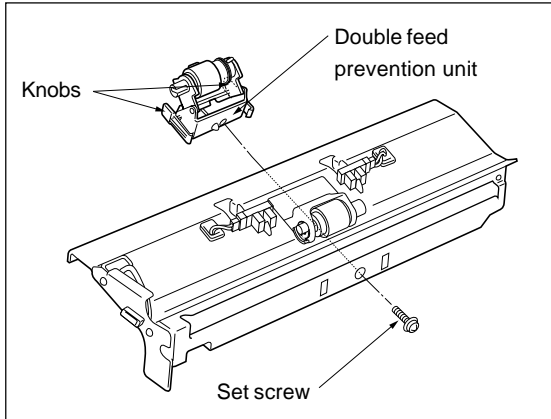

- (4) While pushing the projection of the lever click shaft, withdraw it and remove the double feed prevention roller.

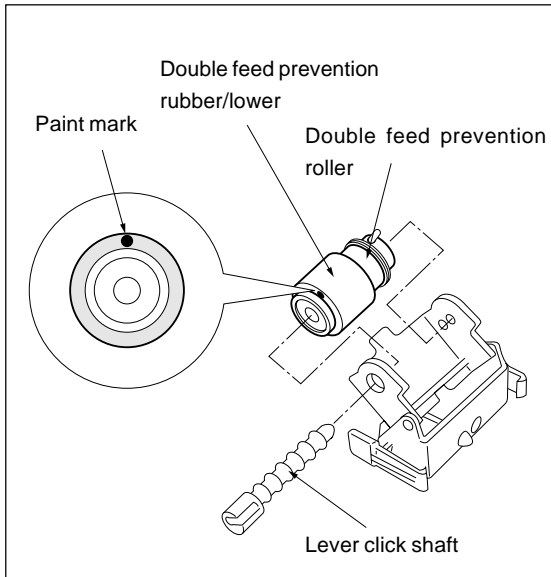

- (5) Remove the double feed prevention rubber/lower from the double feed prevention roller.
- (6) Install by reversing the removal procedure.

**Caution :** Pay attention to the direction in which you install each roller rubber.

When installing the double-feed prevention unit into the main body, be sure to align it with the center of the mark engraved on the main-body plate.

# DB-409/410 PRODUCT SPECIFICATIONS

## [1] Type

**Type:** Tray Paper Feed  
(Front Loading)

## [2] Functions

**Paper size:** A4, A4R, B5, B5R, 8.5 x 11,  
8.5 x 11R

**Paper type:** 16 lb. - 24 lb. high quality  
paper

**Maximum  
paper capacity:** 1,500 Sheets  
(22 lb.)

## [3] Machine data

**Power:** DC24V/5V (supplied from  
main body)

**Power consumption:** Max.40VA (When the PTC  
heater is not in use.)

**Weight:** Approximately 52 lb.

**Machine dimensions:** Length 22.8 in.  
Depth 23.4 in.  
Height 12.2 in.

## [4] Maintenance

**Maintenance:** Same as main body

## [5] Machine environment

**Temperature:** 50 to 86°F

**Humidity:** 20 to 80%RH

**Note :** Specifications are subject to change without  
notice.

# CENTER CROSS SECTION

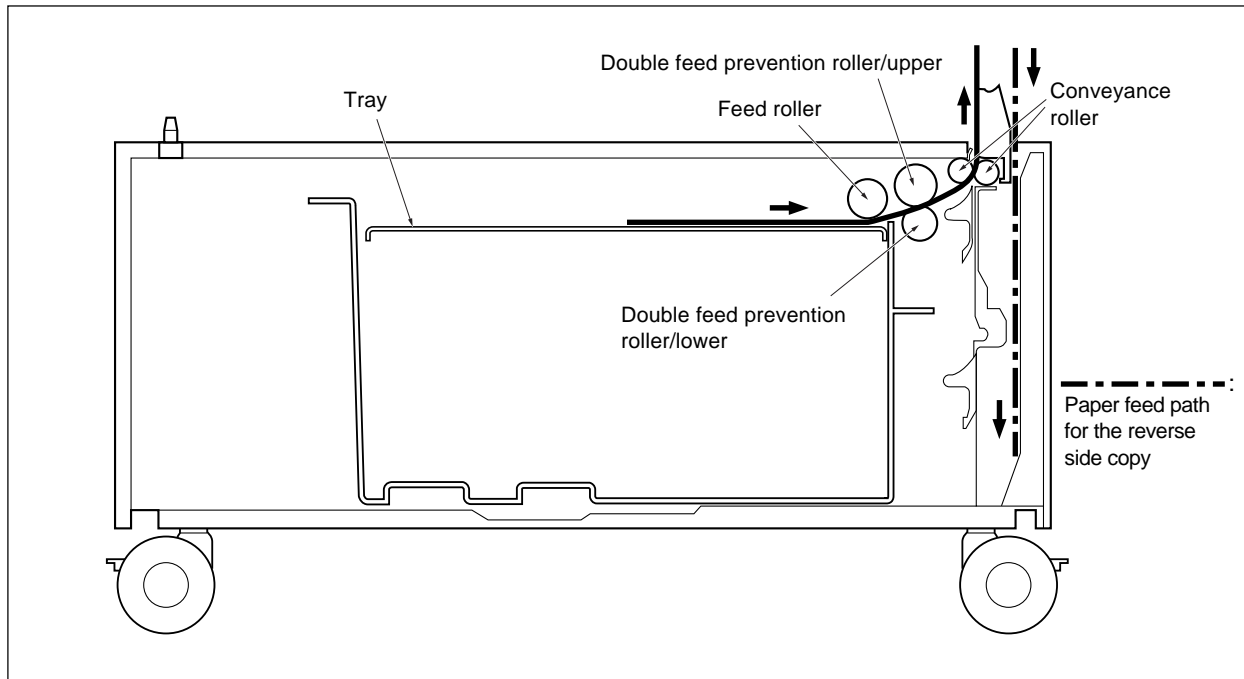

# DRIVE SYSTEM DIAGRAM

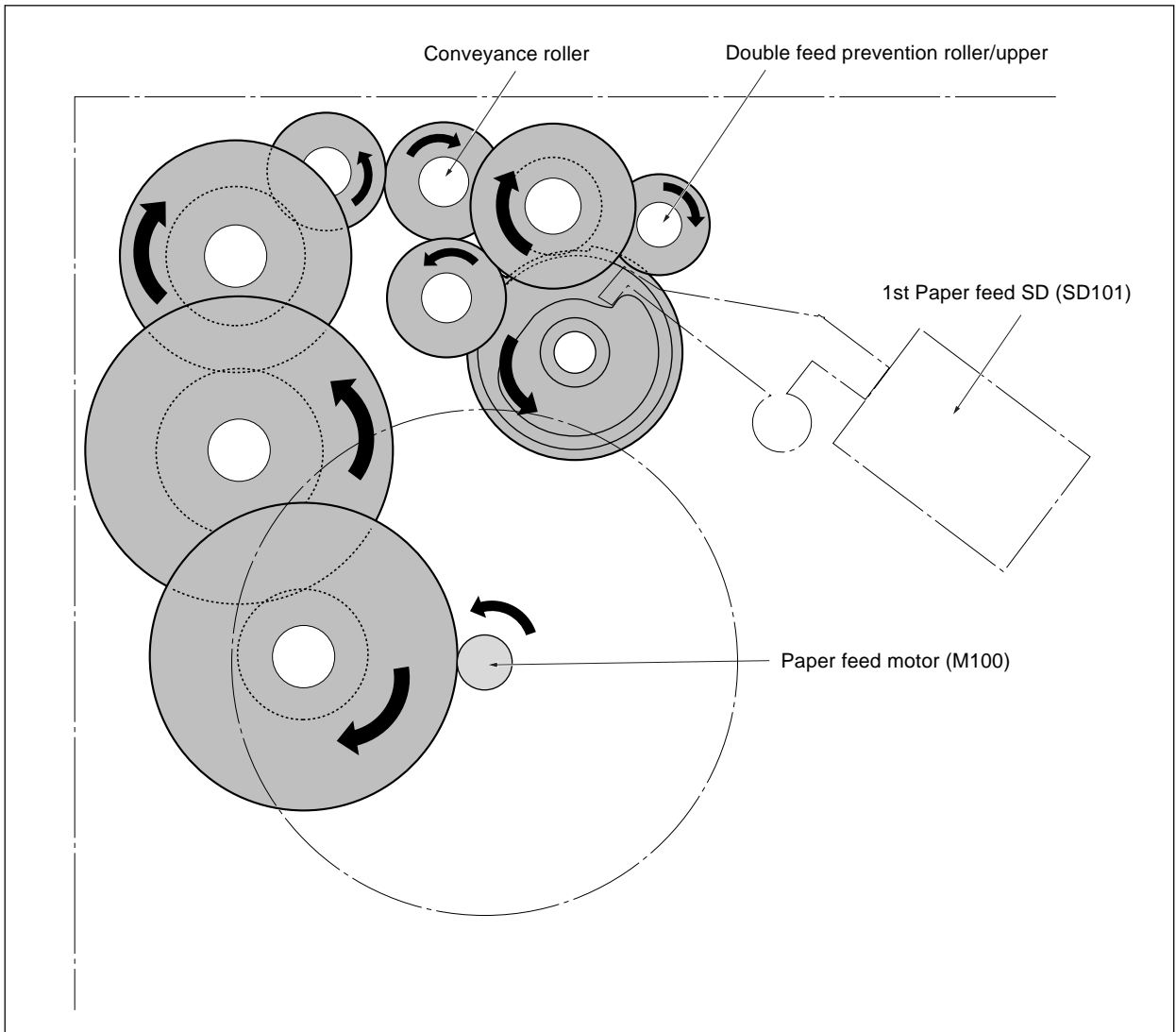

# PAPER FEED SECTION

## [1] Composition

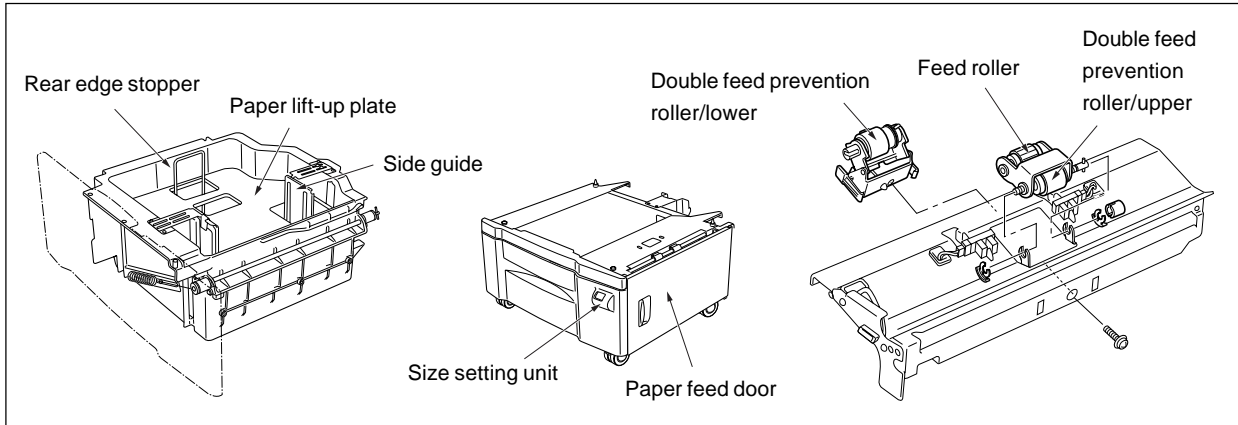

## [2] Mechanisms

Mechanism	Method
Paper feed	Paper feed roller
Paper lift-up *	Paper lift-up plate
Double feed prevention	Torque limiter
Tray loading	Front loading
1st paper feed	Paper feed SD Feed roller
Jam processing	Release of pressure on double feed prevention roller
No paper detect	Photosensor
Paper size detect	Size setting unit
Paper conveyance	Roller conveyance
Conveyance drive	Gears

### \* Paper lift-up

The paper tray (LCT) is suspended on 4 up/down drive wires (wires A, B, C, and D). When paper is supplied to the paper tray, the tray falls under the weight of the paper itself, but through the tension of the drive assist spring, balance with the weight of the paper is maintained.

When the paper tray (LCT) is loaded, the motor rotates, causing the wire to be wound around the drive pulley. As a result, the tray rises.

When the paper tray is withdrawn from the suspension base, the coupling with the drive is disconnected, and the tray falls to the position in which the balance between the weight of the paper and the drive-assist spring is maintained.

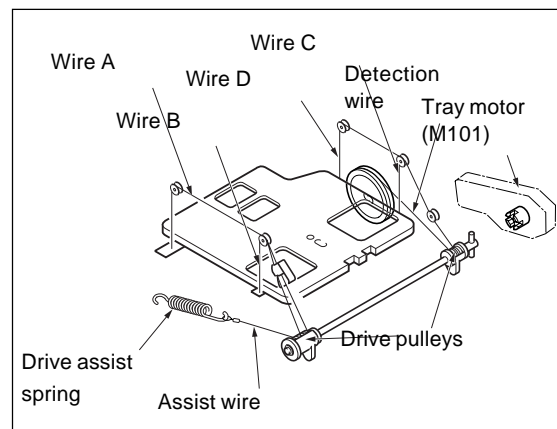



### [3] Paper feed and no paper detection control

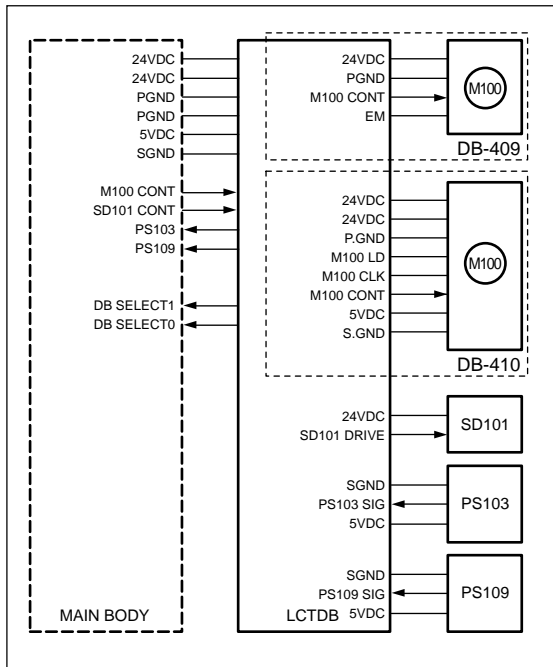

Paper feed is carried out by transmitting the drive of the M100 (DB paper feed motor) to the paper feed roller and to the feed roller. When feed starts, SD101 (1st. paper feed SD) raises and lowers the feed roller and contacts the paper.

Drive of the M100, SD101 is carried out by LCTDB (LCT drive board) and controlled by the main body.

No paper detection is carried out with PS103 (No paper detect PS) and controlled by the main body via the LCTDB.

A related signal is the PS109 (Paper level detect PS2) which sent the remaining paper level to the main body.

#### 1. Operation

##### a. Paper feed operation timing

###### (1) 1st. sheet start

A specified time after start button is turned ON

###### (2) 2nd. sheet start

A specified time after 1st. sheet SD101 is turned ON

###### (3) OFF timing

A specified time after SD101 is turned ON

##### b. No paper detection

If paper in the tray is used up, PS103 goes OFF and no paper detection signal is sent to the main body via the LCTDB.

#### 2. Signals

##### a. Input signals

###### (1) PS103 (PS103 → LCTDB)

Tray paper/no paper detection signal

[H]: no paper

[L] : with paper

###### (2) PS109 (PS109 → LCTDB)

Paper level in tray detection signal

Turns on with [L], sends main body that little paper is left.

###### (3) SD101 CONT (MAIN BODY → LCTDB)

SD101 ON/OFF control signal from main body

[H]: OFF

[L] : ON

##### b. Output signals

###### (1) M100 CONT (LCTDB → M100)

M100 drive control signal

[H]: M100 OFF

[L]: M100 ON

###### (2) M100 CLK (LCTDB → M100)

M100 rotation control board clock signal

###### (3) SD101 (LCTDB → SD101)

SD101 drive control signal

[H]: OFF

[L] : ON

###### (4) PS103 (LCTDB → MAIN BODY)

Paper/no paper detection signal sent to main body

###### (5) DB SELECT (LCTDB → MAIN BODY)

DB type identification signals that is sent to the main body

DB	Signal	
	DB-SELECT 1	DB-SELECT 0
DB-409/410	L	H
Not connected	H	H
Undefined	L	L

## [4] Tray up and down control

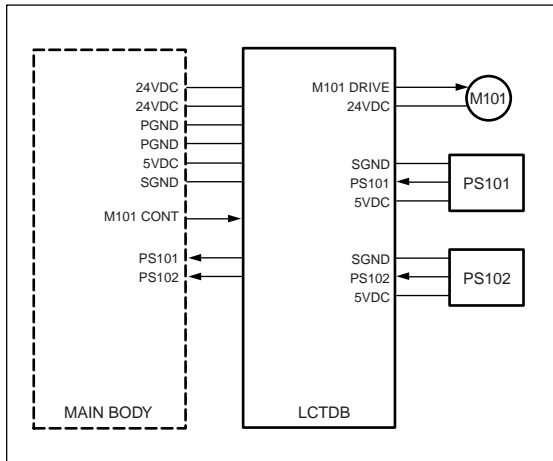

### 1. Operation

When the paper feed tray of each level is set, PS101 (Tray detect PS) detects the tray, M101 (Tray motor) turns ON and lifts the base plate in the tray. When the tray is lifted, PS102 (Paper level detect PS1) detects the paper upper limit and turns on, then M101 turns off and the raising of the tray is completed.

The down operation of the trays is performed mechanically.

### 2. Signals

#### a. Input signals

- (1) PS101 (PS101 → LCTDB)

Tray detect signal

By turning with [L] showing, M101 raises the paper in the upper tray.

- (2) PS102 (PS102 → LCTDB)

Upper tray upper limit detection signal

When the upper tray paper is lifted and arrives at the upper limit position, the signal becomes [H] and M101 is turned off.

- (3) M101 CONT (MAIN BODY → LCTDB)

M101 ON/OFF control signal from main body

#### b. Output signals

- (1) M101 DRIVE (LCTDB → M101)

M101 drive control signal

[L]: M101 ON

[H]: M101 OFF

- (2) PS101 (LCTDB → MAIN BODY)

Tray detection signal sent to main body

- (3) PS102 (LCTDB → MAIN BODY)

Paper upper limit detect signal sent to main body

**[5] Paper size detection control**

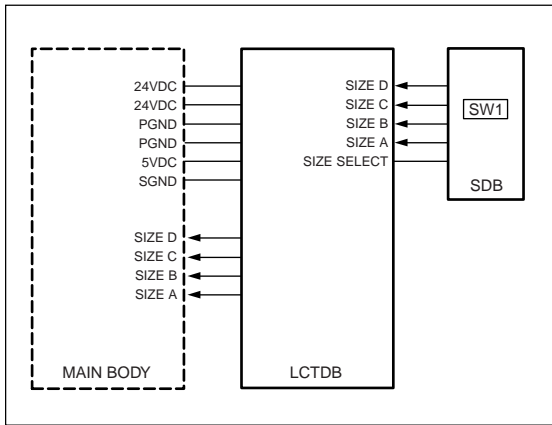

Tray paper size is detected in the main body by a signal sent from SDB (size detection board) via the LCTDB (LCT drive board).

**1. Operation**

**a. Tray paper size detection**

Paper size for either tray is set by SW1 above SDB and the LCTDB detects the switch signal corresponding to the position of SW1.

The relation between switch signal and paper size is as follows.

Paper size (Label display order)	Switch signal			
	SIZE A	SIZE B	SIZE C	SIZE D
8.5 x 11R				
A4	○			
A4R		○		
8.5 x 11	○	○		
8.5 x 11R			○	
B5R	○		○	
B5		○	○	
A4	○	○	○	
A4R				○
8.5 x 11	○			○

**2. Signals**

**a. Input signal**

- (1) SIZE A - D (SDB -> LCTDB)  
Tray paper size detect signal

**b. Output signal**

- (1) SIZE A - D (LCTDB -> MAIN BODY)  
Paper size detection signal sent to main body

## [6] Control of paper-level detection

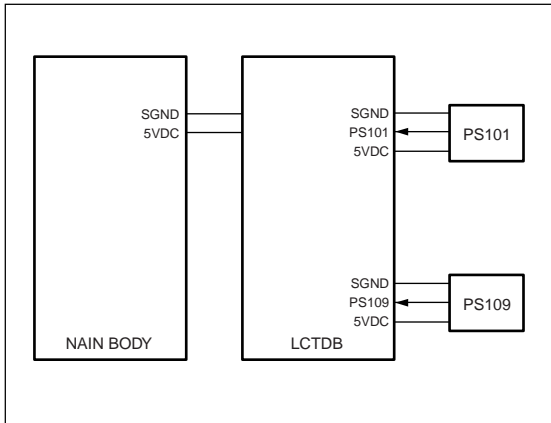

After the trays have been set in the machine, paper level is detected by PS101 (tray detect PS) and PS109 (paper level detect PS2).

As the paper level in tray runs low, the actuator at the rear part of the tray gradually rotates as illustrated below. The remaining paper level is detected based on the ON/OFF states of PS101 and PS109.

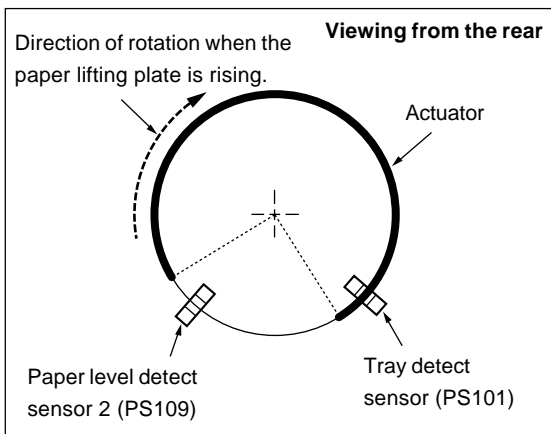

### 1. Operation

#### a. Detection of paper level in tray

The following shows the relation between the paper level and the number of slit detections by the sensor (PS101 or PS109).

Paper level	PS101	PS109
Full	○	
Medium	○	○
Low		○

# DISASSEMBLY/ASSEMBLY

⚠ Caution: Make sure the power plug is taken out of the socket.

## [1] Removing and reinstalling the paper feed tray

- (1) Pull out the paper tray and take out the 4 set screws and remove the tray front cover.

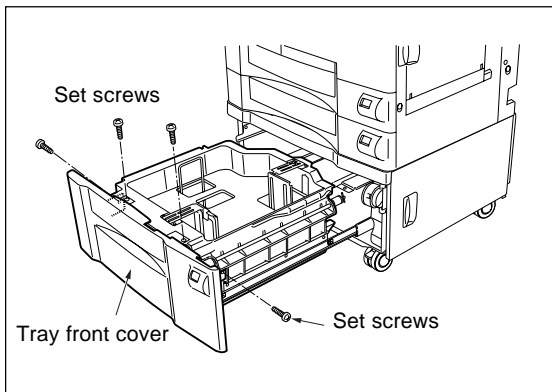

- (2) Remove the 5 set screws from the guide rails and remove paper tray from guide rails.

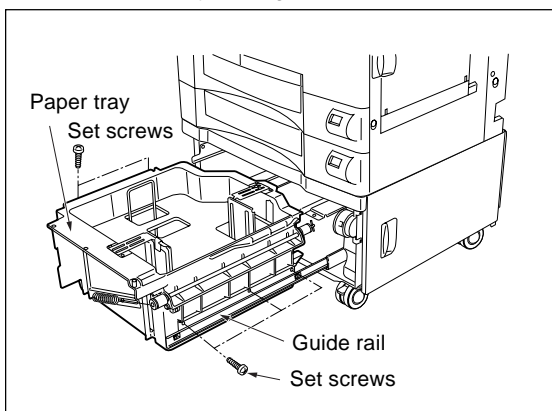

- (3) Install by reversing the removal procedure.

## [2] Removing and reinstalling the paper feed unit

- (1) Remove the tray cover and the paper tray.
- (2) Open the paper feed door, remove the three set screws, then remove the size setting unit.

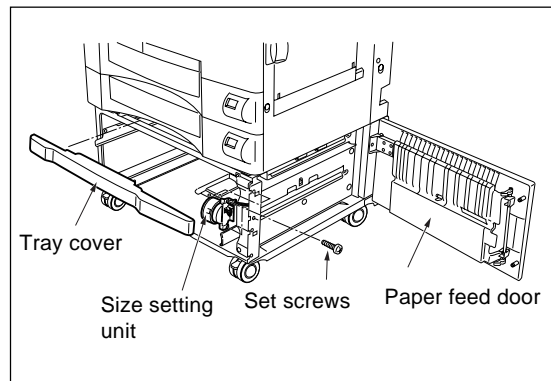

- (3) Remove the 3 set screws and remove the cover.

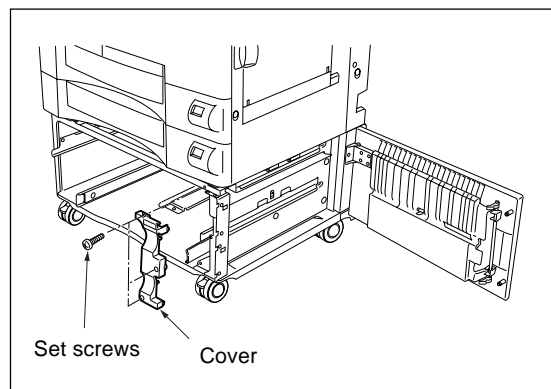

- (4) Remove the paper feed unit connector.

- (5) Remove the set screw indicated by the arrow marking, and remove the paper-feed unit by pulling it forward.

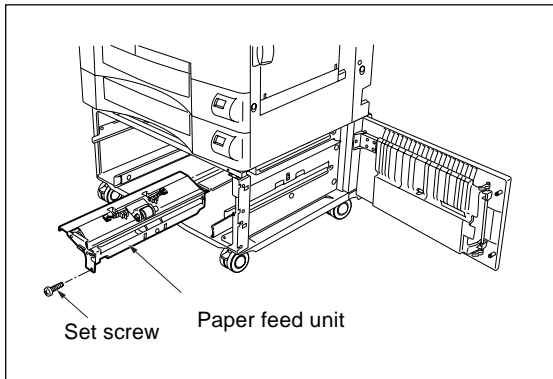

- (6) Install by reversing the removal procedure.

**Caution 1:** Immediately after installing the paper feed unit, as the swing gear and the paper feed solenoid are not in the correct position, it sometimes happens that paper is not fed. For this reason, always make a copy to confirm that operation is normal.

**Caution 2:** Install so that the swing gear shaft enters the paper feed roller unit.

### [3] Replacing the feed roller rubber and double feed prevention rubber/upper

- (1) Remove the paper feed unit.
- (2) Remove the fixing rings and bearings.
- (3) While withdrawing the paper feed shaft, remove the double feed prevention roller/upper from the paper feed roller unit.

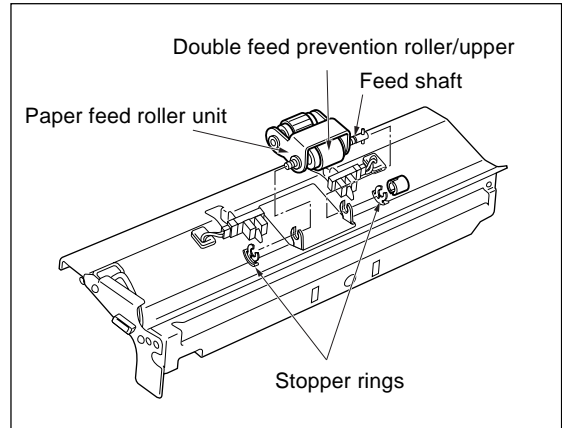

- (4) Removing the fixing ring and remove the feed roller by withdrawing the guide shaft in the direction shown by the arrow.
- (5) Remove the feed rubber form the feed roller.
- (6) Remove the feed shaft and then remove the double feed prevention roller/upper.
- (7) Remove the double feed prevention rubber/upper from the double feed prevention roller/upper.

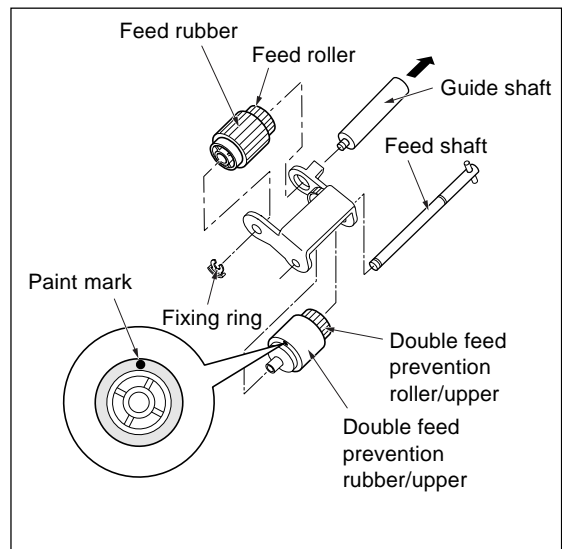

- (8) Install by reversing the removal procedure.

**Caution:** Pay attention to the direction in which you install each roller rubber. Install so that the swing-gear shaft enters the paper feed roller unit.

#### [4] Replacing the double feed prevention rubber/lower

- (1) Remove the paper feed unit.
- (2) Remove the set screw.
- (3) Pushing the knobs on either side of the double feed prevention unit, then remove by drawing it forward.

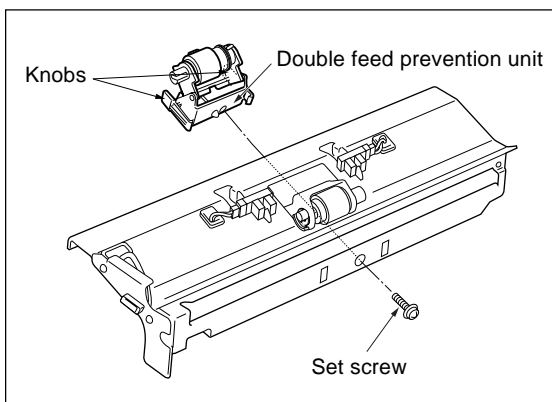

- (4) While pushing the projection of the lever click shaft, withdraw it and remove the double feed prevention roller.

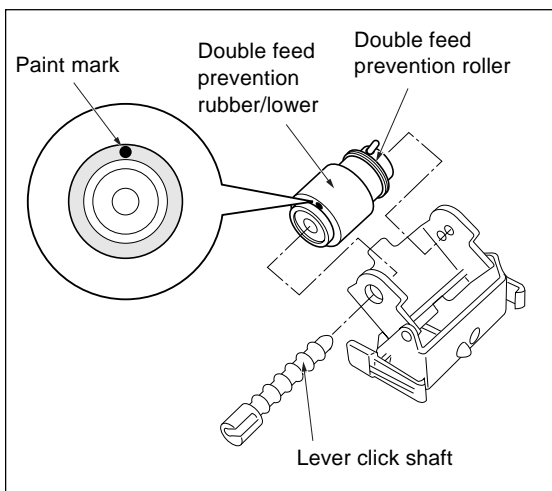

- (5) Remove the double feed prevention rubber/lower from the double feed prevention roller.
- (6) Install by reversing the removal procedure.

**Caution:** Pay attention to the direction in which you install each roller rubber.

When installing the double-feed prevention unit into the main body, align the unit with the center of the marking stamped on the main-body plate.

## [5] Replacing the wires

**Caution 1:** After finishing wire replacement or rewiring, raise and lower the tray by hand to confirm that it rises and lowers smoothly.

**Caution 2:** Do not cross wires or run them one on top of another.

**Caution 3:** After installing wires, adjust the tray's tilt.

### Wire lengths

Wire A:	518.6±0.4mm
Wire B:	293.6±0.4mm
Wire C:	317.5±0.4mm
Wire D:	423.0±0.4mm
Assist wire:	245.2±0.5mm
Detection wire:	394.8±0.4mm

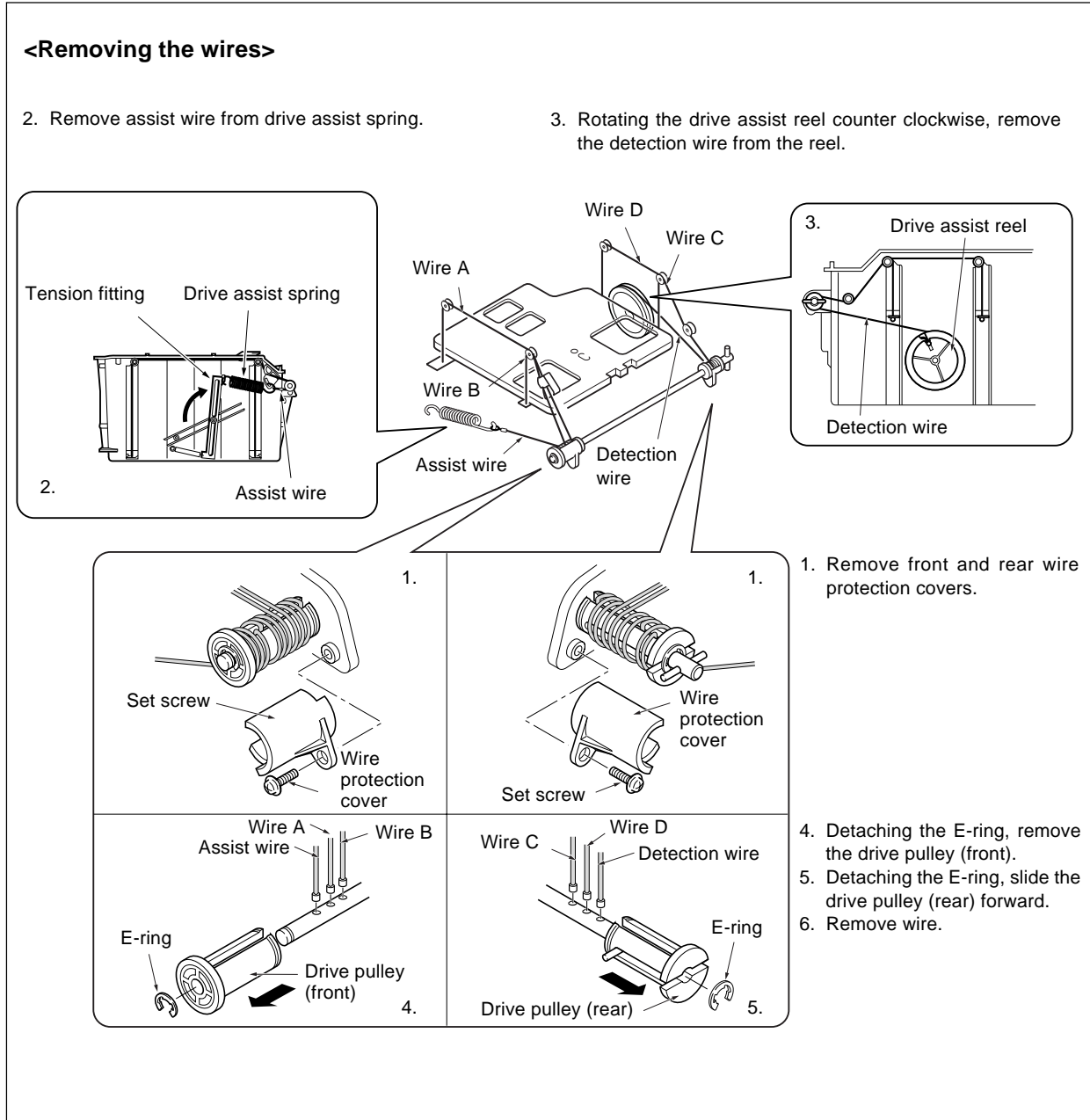



**<Stringing wires>**

7. Attach the assist wire to the drive assist spring. Turn the tension fitting to apply tension, and tighten the screw.

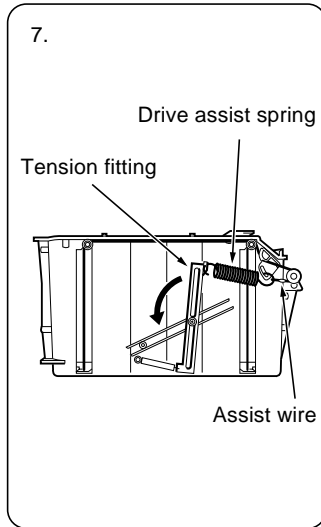

1. Pass wires A, B, C, and D through tray.
2. Pass wires A and B along pulley groove and pass over the adjustment material.
3. Pass wires C and D along pulley groove.

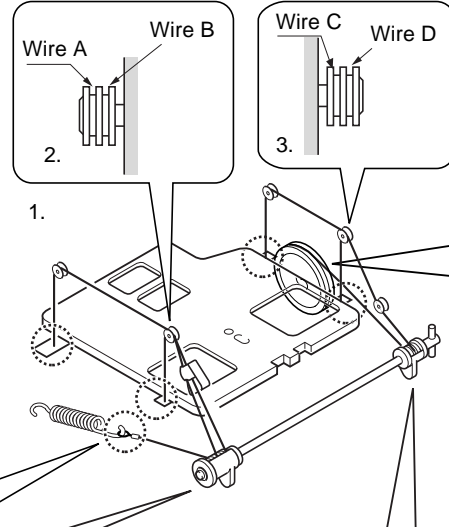

8. Raise the paper lift plate. With the wire tip pointing upward, wind wires C and D around the drive pulley 3 times. Then wind the detection wire 1 time around to the left (counterclockwise).

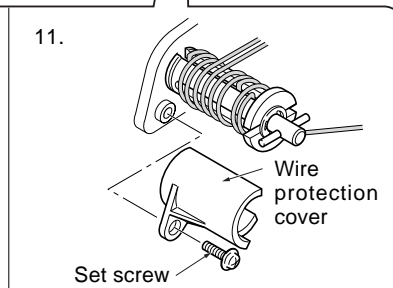
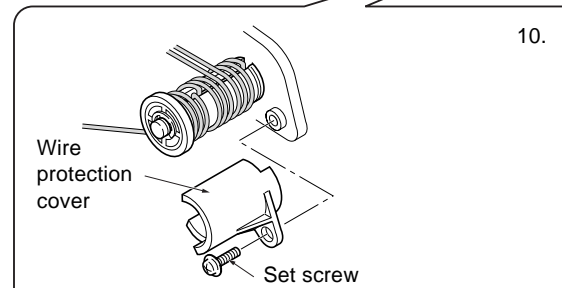
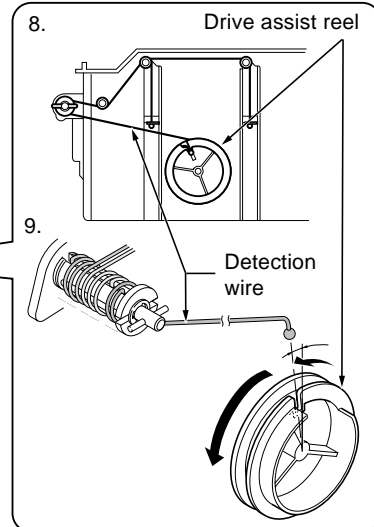

9. Rotate the detection wheel approximately 1 turn counterclockwise, so that the detection wire winds 1 time around the reel (starting from the top).

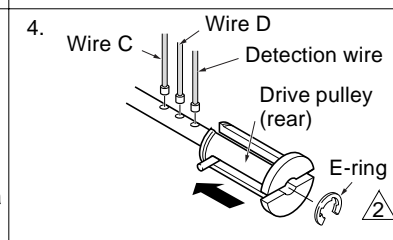
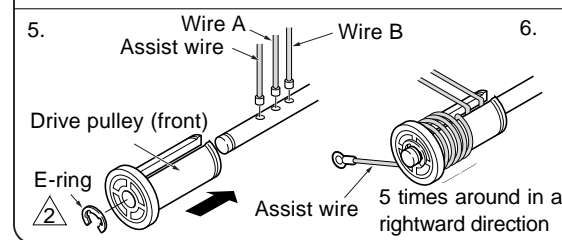

5. Having inserted assist wire and wires A and B into the drive spindle, push the drive pulley on and fasten the E-ring.
6. Wind the assist wire 5 times around the drive pulley in a rightward direction.

4. Having inserted detection wire and wires C and D into the drive spindle, push the drive pulley on and fasten with the E-ring.

10. Install the (front) wire protection cover.

11. Install the (rear) wire protection cover.

Blank

# DB-209/210 ELECTRICAL PARTS LAYOUT DRAWING

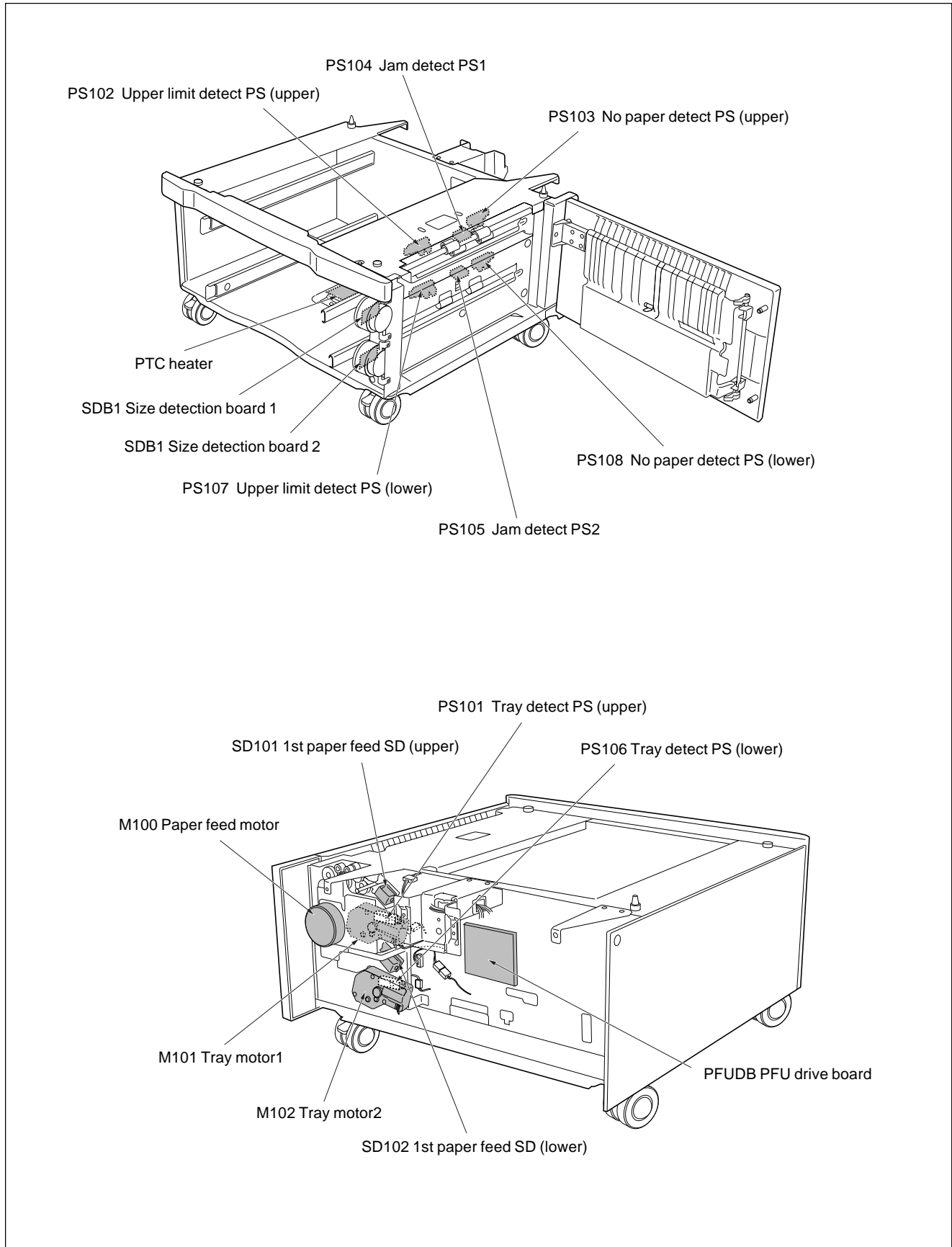

# DB-409/410 ELECTRICAL PARTS LAYOUT DRAWING

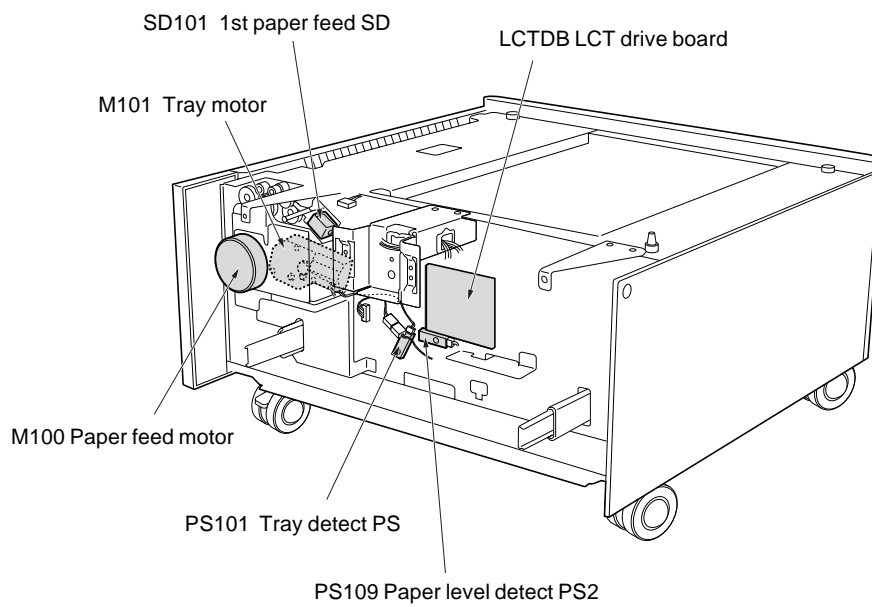
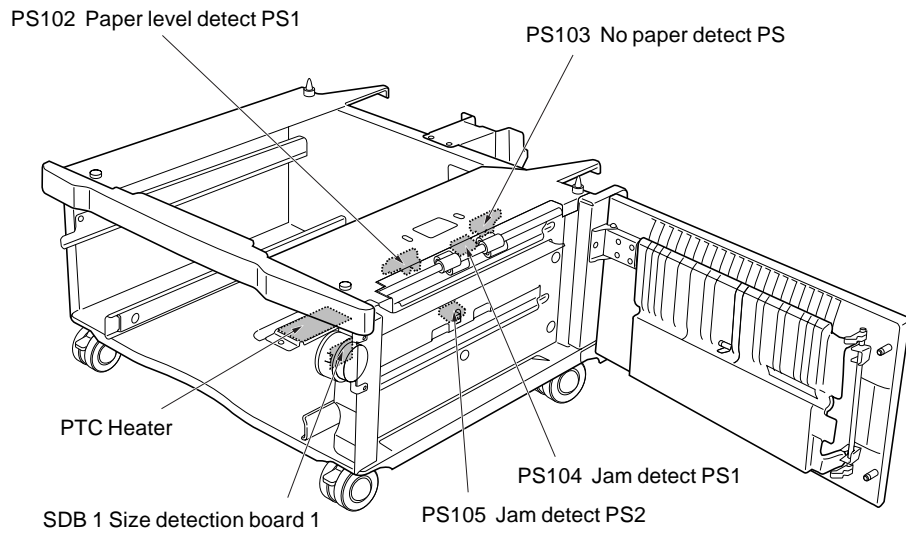

# DB-209/210 CONNECTOR LAYOUT DRAWING

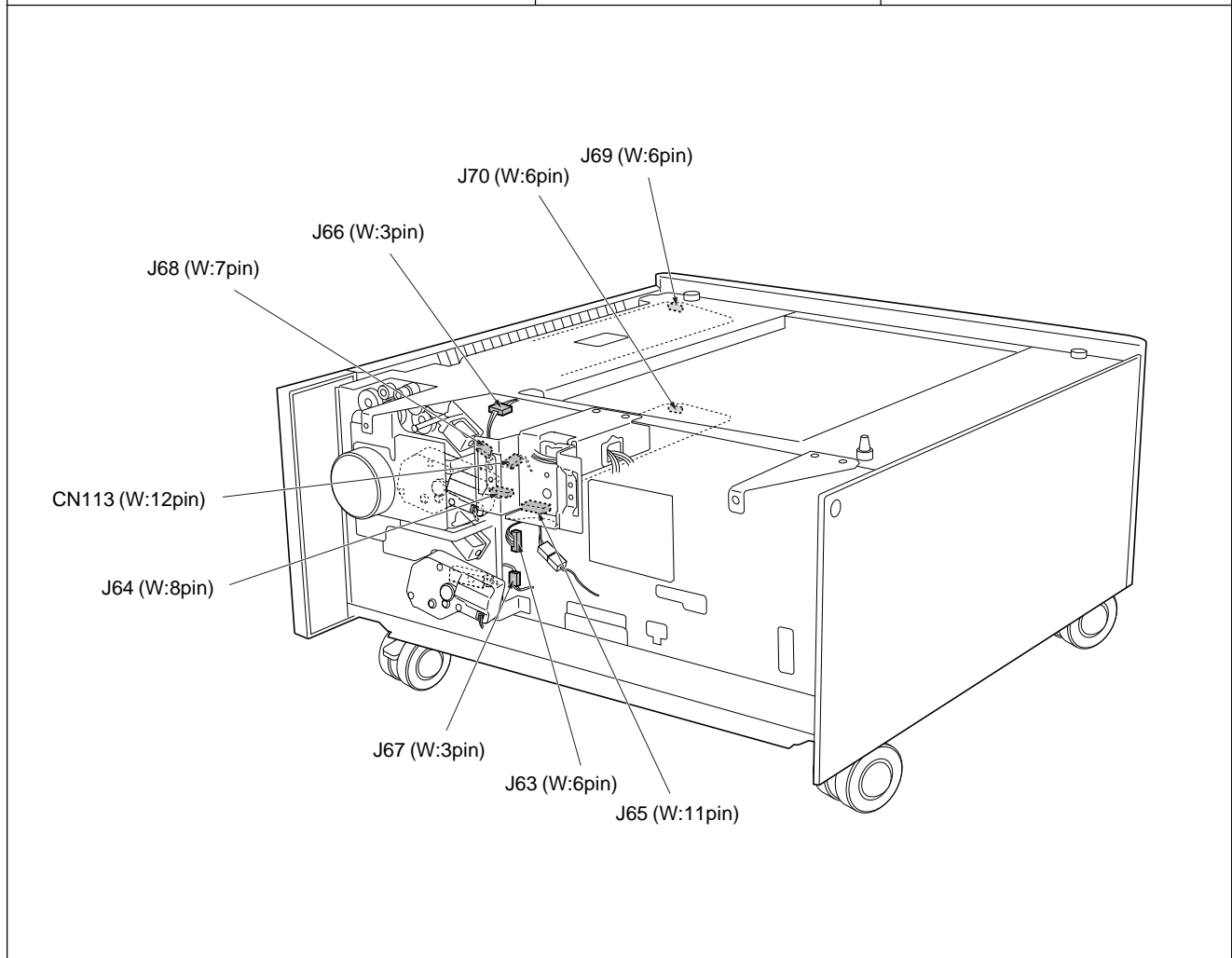
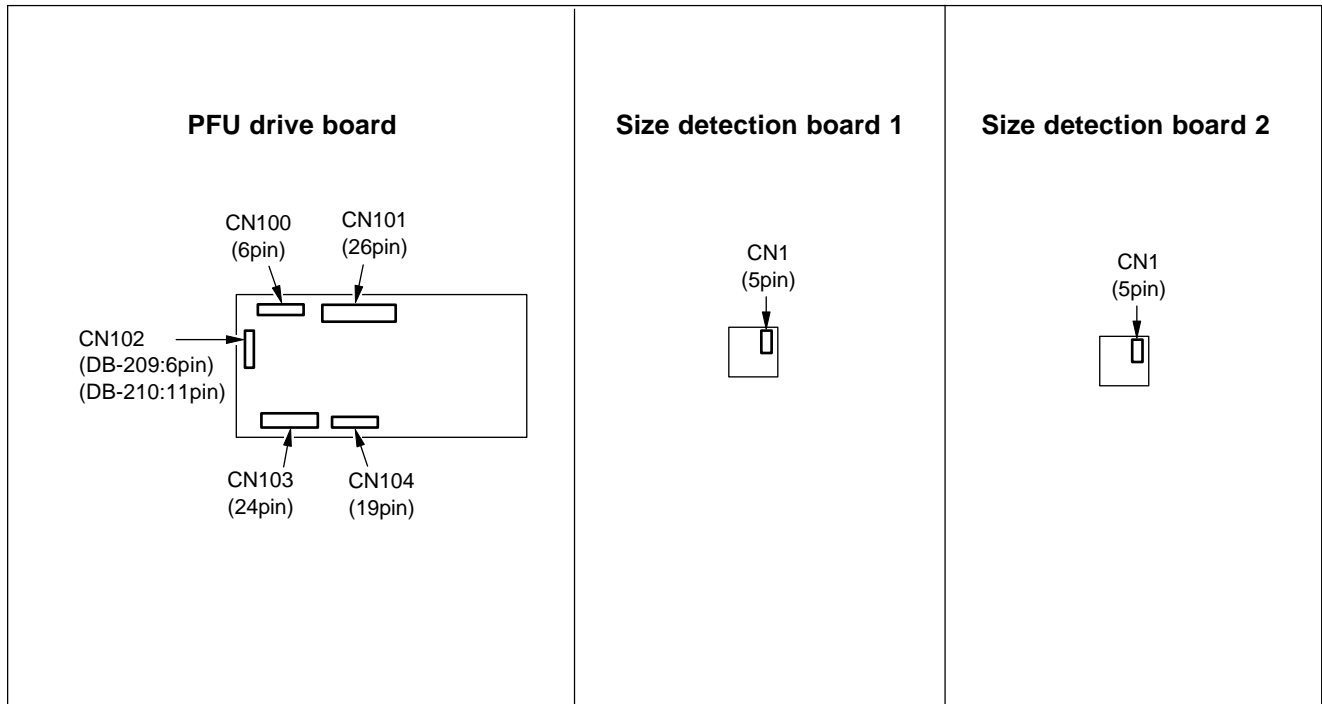

# DB-409/410 CONNECTOR LAYOUT DRAWING

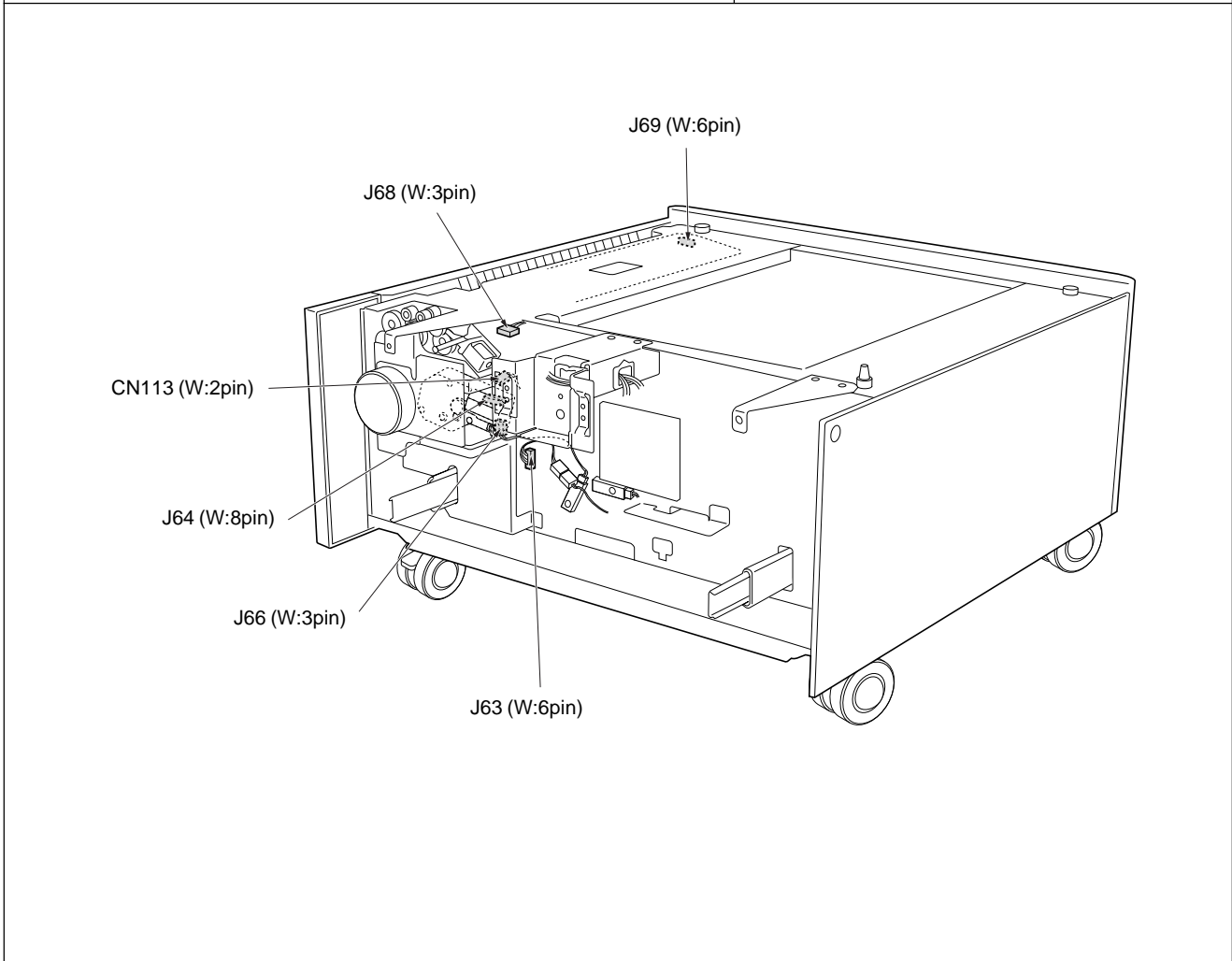
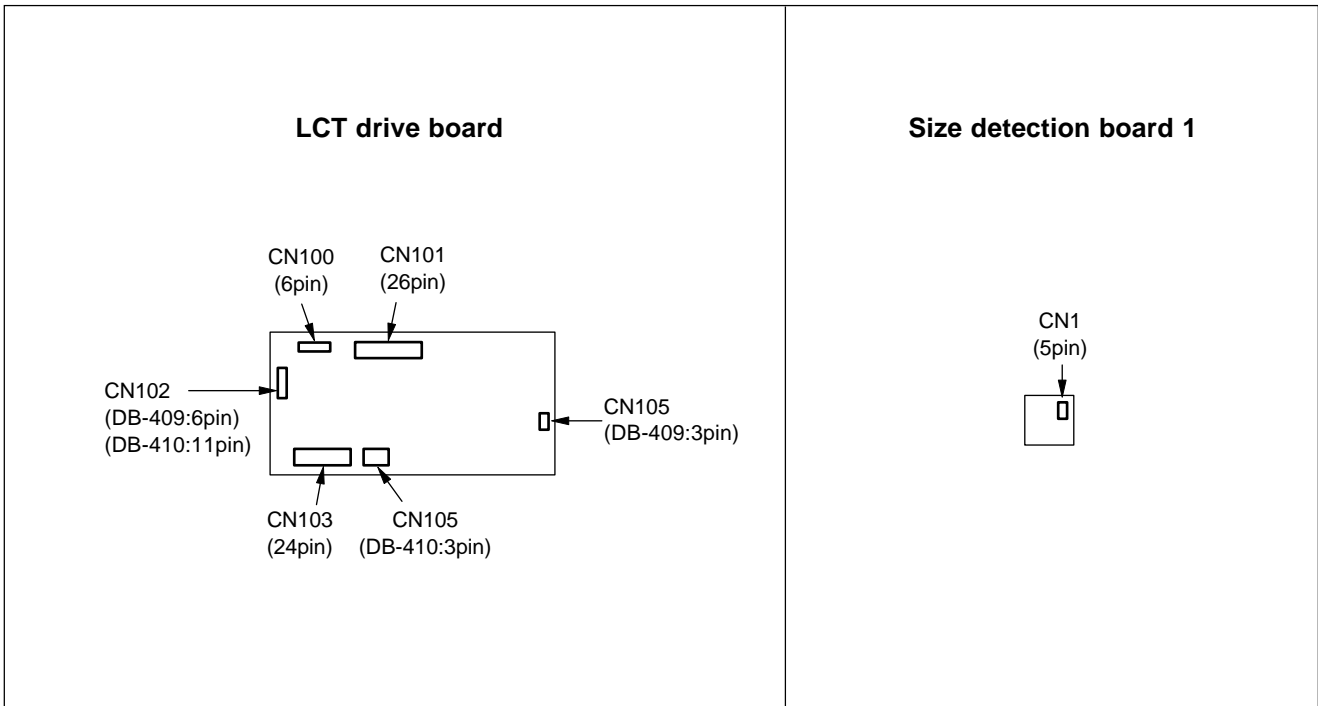

# DB-209/DB409 TIME CHART (8.5X11, LIFE SIZE, 3 COPIES, FEED FROM TRAY 3)

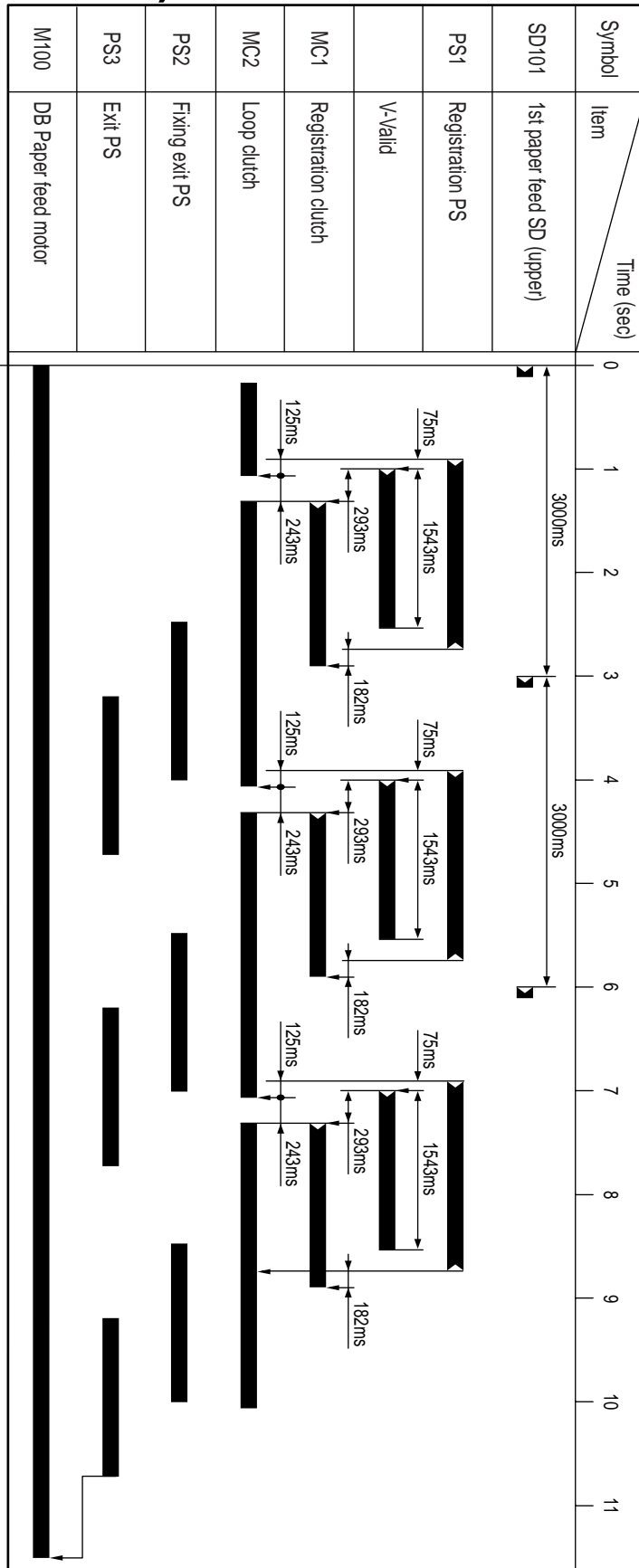

Blank



# DB-209/210/DB-409/410 OVERALL WIRING DIAGRAM

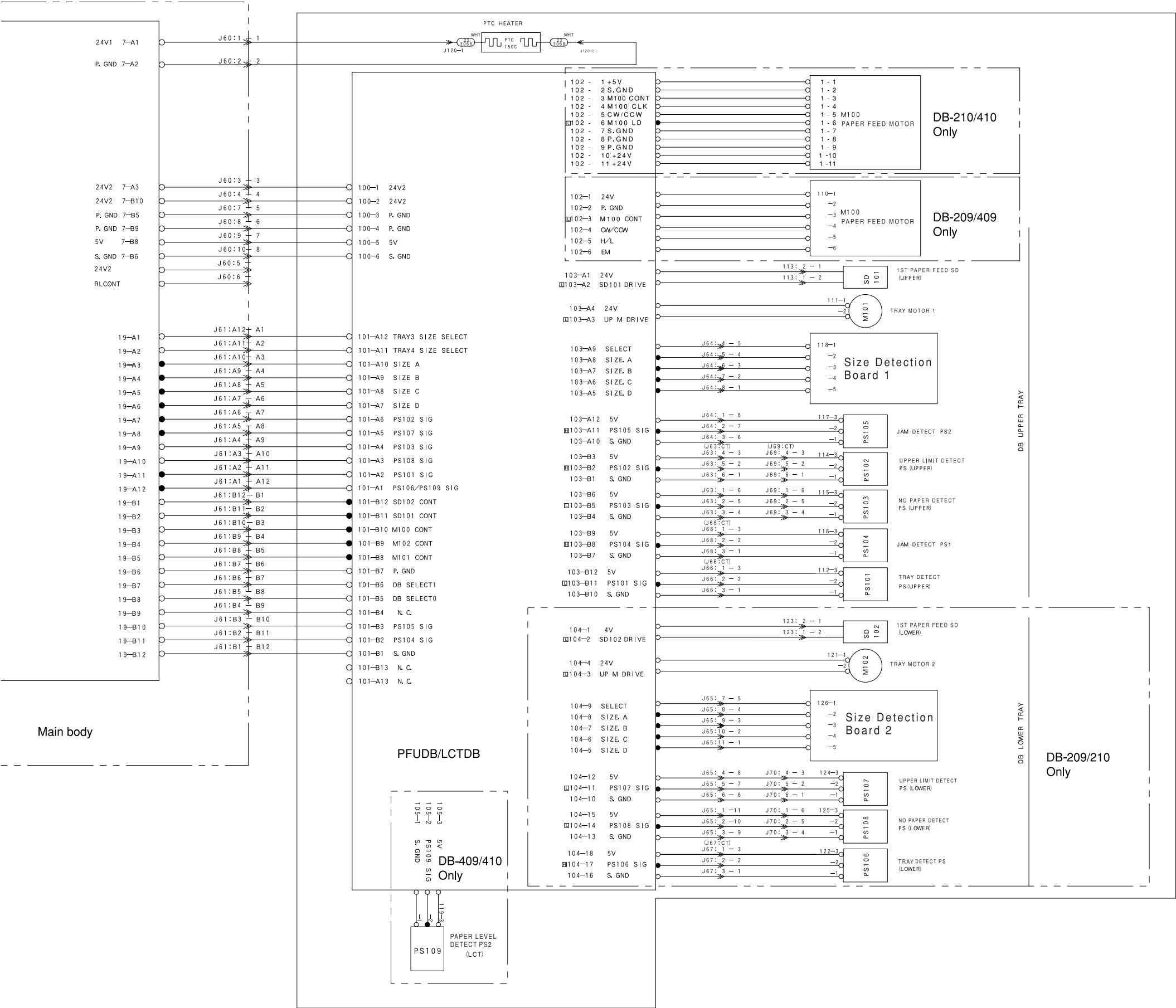

[How to see the diagram]

1. The signals shown reflect levels present under normal idling conditions with the main switch turned ON.

2. Wiring symbols in the figure are as follows.

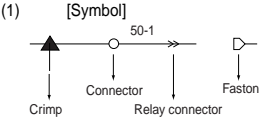

(2) Signal types are as follows:

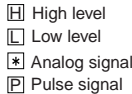

(3) (RC) is the flat cable.

(4) Signal flow

The solid black circle (●) among the connector symbols (○) indicates the direction of signal flow. Example

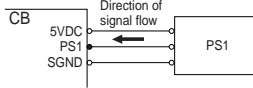

Blank

**Konica**

**PARTS CATALOG**

Model  
**DB-209/DB-409**

MARCH 2001  
SECOND EDITION

**KONICA BUSINESS TECHNOLOGIES, INC.**



## How to use this catalog

This parts catalog includes illustrations and part numbers for all replacement parts and assemblies used in this model.

**Model-specific parts** are identified in the illustrations with reference numbers. Use the reference number to locate the corresponding part number on the facing page.

**Common hardware items**, such as screws, nuts, washers, and pins, are identified in the illustrations with reference letters. Use the reference letter to locate the corresponding part number on the hardware listing in the lower right hand corner of the facing page.

**If you know a part number**, but don't know where the part is used, use the numerical index to determine the page number and reference number for that part. Because some common parts are used in several places, there may be more than one entry. Refer to the illustrations to see where the part may be used.

**If you know a part's description**, but don't know where to look to find the part number, use the alphabetical index to determine likely page and reference numbers. Then look at the illustrations to determine that you have identified the correct part. Locate the part number using the listing on the opposite page.

**Retail pricing** that appears with the numerical index, while valid when this catalog was printed, is subject to change without notice. The prices are only suggested prices and are provided only for reference. Dealers may determine their own selling prices. For up-to-date pricing, refer to current Konica price lists or contact the Konica Parts Distribution Center.

### How to order parts

Use standard Konica parts ordering procedures to obtain these parts. For ordering options, contact Konica's Parts Distribution Center.

When ordering parts, be sure to specify part numbers exactly as listed in this catalog.

NOTE: Electrical parts may include previously used components.

This page left blank intentionally.

How to use this catalog . . . . . iii  
Contents . . . . . 1

DB-209 . . . . . 2

Wiring . . . . . 12

DB-409 . . . . . 14

Wiring . . . . . 24

Alphabetical index . . . . . 27  
Numerical index, Retail price list . . . . . 29

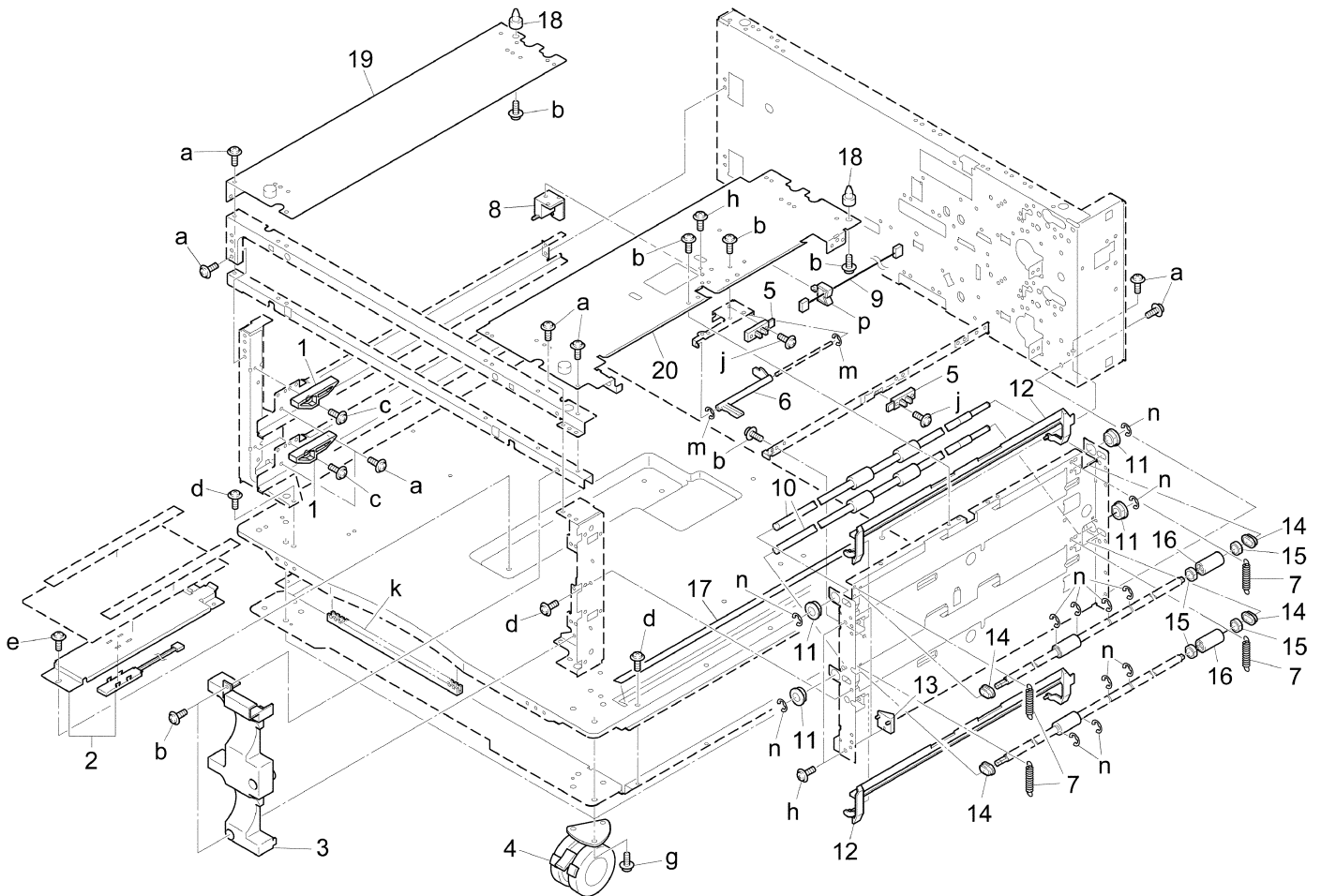



REF. NO.	PART NUMBER	DESCRIPTION
1	26NA47350	Cassette stopper
2	13HA-1121	Inner heater assembly
3	13GU12050	Cassette detecting cover
4	12XQ10040	Main support roller/A
5	552085510	Photosensor
6	13HA40060	Actuator/Upper
7	13HA40070	Driven spring
8	13GU40110	Shaft holder part
9	13HA90030	LCT wiring/2
10	13HA40020	Paper feed connecting roller/3
11	26NA40820	Paper feed slide shaft holder
12	26NA40270	Side guide plate
13	13HA10420	Lock part
14	13HA40150	Paper feed driven shaft holder
15	26NA40890	Slide bearing
16	26NA40680	Paper feed driven roller/Lower
17	13HA10530	Guide sheet/2
18	13HA10370	Main positioning shaft
19	13HA-1090	Main support plate left assembly
20	13HA-1070	Main support plate right assembly

HARDWARE	
REF. LTR.	PART NUMBER
a	00Z283061
b	00Z193061
c	00Z183061
d	00Z283081
e	00Z193041
g	00Z194101
h	00Z253081
j	00Z183121
k	00Z924316
m	00Z670206
n	00Z670606
p	00Z921941

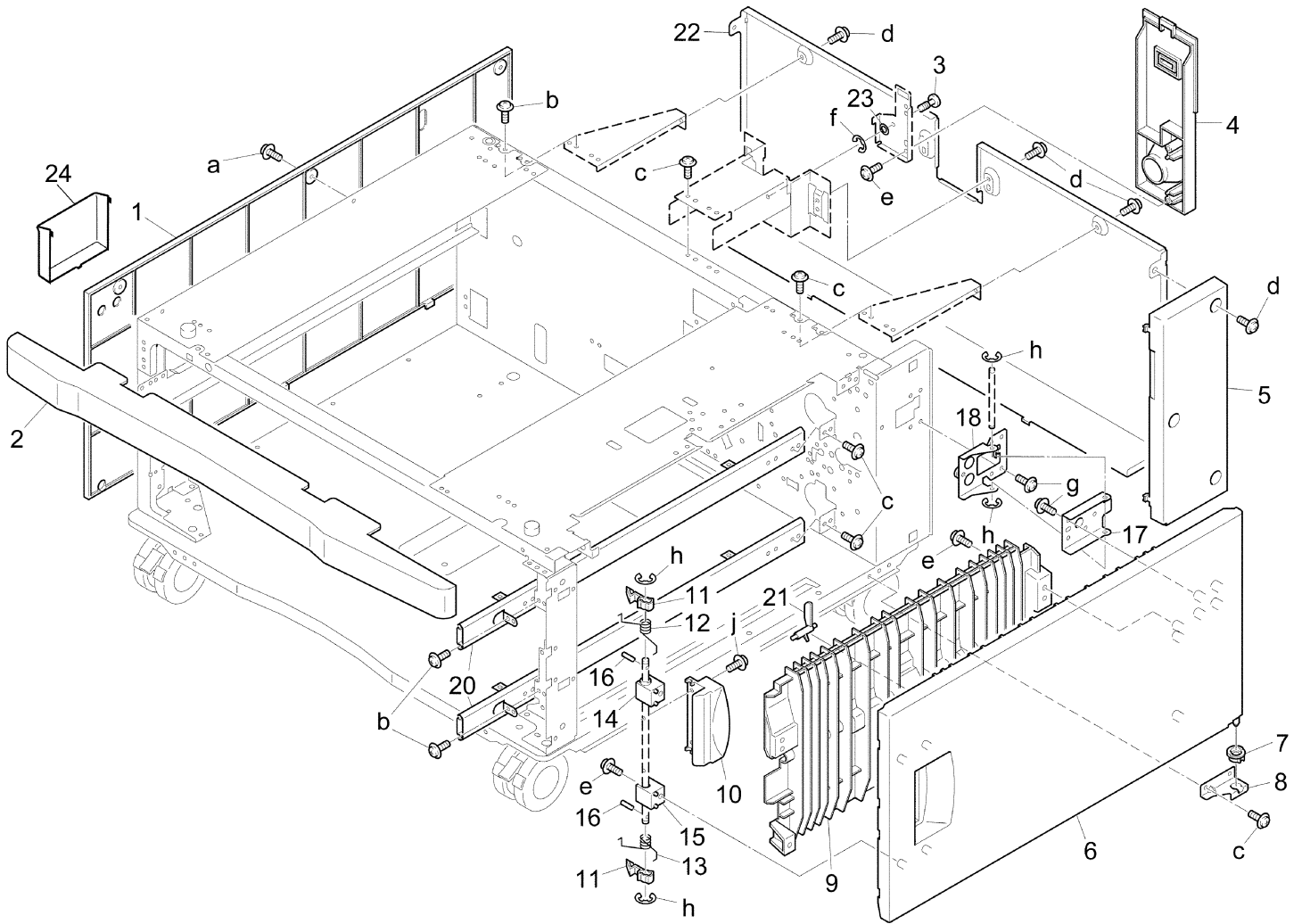

REF. NO.	PART NUMBER	DESCRIPTION
1	13HA12060	Side cover/Left
2	13GU12040	Front fixed cover
3	26NA53931	Fixed screw
4	13HA12150	Cord cover
5	13HA12080	Side cover/Right
6	13HA12020	Door/Right
7	13HA10470	Door fulcrum part
8	13HA10460	Door fulcrum plate
9	13HA40080	Guide plate/Middle
10	26NA50091	Open-close knob
11	26NA50080	Lock claw
12	13HA12160	Lock spring/Upper
13	13HA12170	Lock spring/Lower
14	26NA50630	Shaft holder part/Upper
15	26NA50640	Shaft holder part/Lower
16	466078010	Pin A
17	13HA10340	Hinge plate/A
18	13HA-1260	Guide plate/B assembly
19	*	Not used
20	26NA10061	Cassette rail/Right
21	13HA10170	Actuator/Lower
22	13HA12070	Rear cover
23	13HA10550	Spacer/A
24	26NA12540	Accessories holding panel

HARDWARE	
REF. LTR.	PART NUMBER
a	00Z283081
b	00Z193061
c	00Z283061
d	00Z193062
e	00Z253081
f	00Z670256
g	00Z254081
h	00Z670306
j	00Z193081

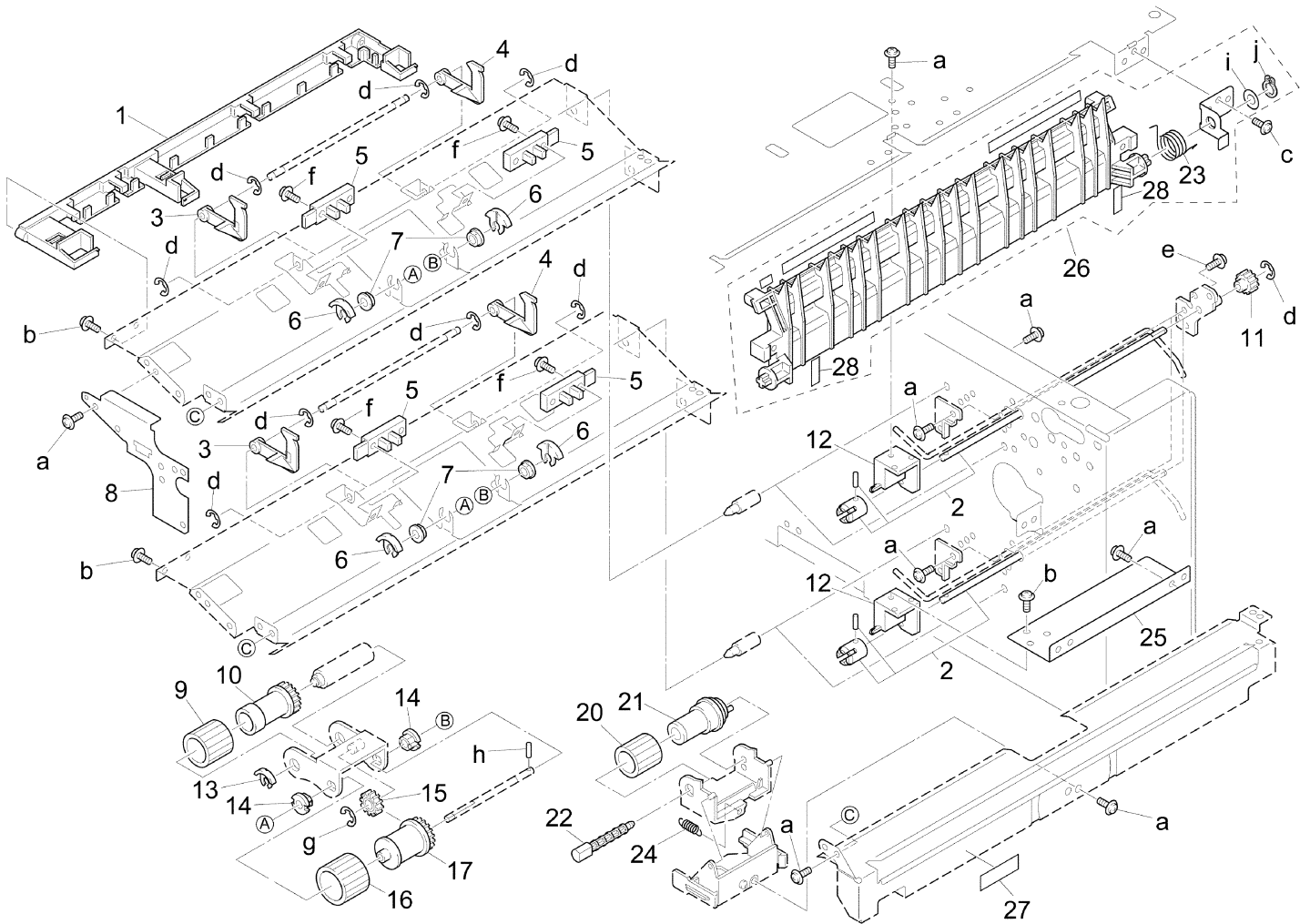

REF. NO.	PART NUMBER	DESCRIPTION
1	13HA40040	Wiring guide part
2	13HA-4040	Paper feed shaft/Rear assembly
3	26NA40280	Paper detecting actuator
4	26NA40750	Paper detecting actuator/2
5	552085510	Photosensor
6	26NA40700	Shaft positioning part
7	540076010	Paper feed shaft holder
8	13HA40030	Paper feed mount plate
9	26NA40090	Paper feeding rubber
10	26NA40080	Feeding roller
11	26NA16310	Paper feed gear (Z=15)
12	13GU40110	Shaft holder part
13	40AA40150	Shaft positioning part
14	40AA76040	Feeding shaft holder
15	26NA40510	Paper feed idler gear (Z=17)
16	26NA40110	Double feed preventive rubber/Upper
17	26NA40100	Double feed preventive roller/Upper
18	*	Not used
19	*	Not used
20	26NA40120	Double feed preventive rubber/Lower
21	26NA40500	Double feed preventive roller
22	40AA40181	Lever click shaft
23	13HA10450	Paper feed rotary spring
24	40AA40450	Double feed pressure spring
25	13GU40100	Shaft holder mount plate
26	13HA-1131	Guide plate/Middle assembly
27	13HA40180	Holder part
28	13HA10560	Guide sheet/3

HARDWARE	
REF. LTR.	PART NUMBER
a	00Z193061
b	00Z253081
c	00Z194061
d	00Z670306
e	00Z193051
f	00Z183121
g	00Z670406
h	00Z712106
i	00Z610501
j	00Z600506

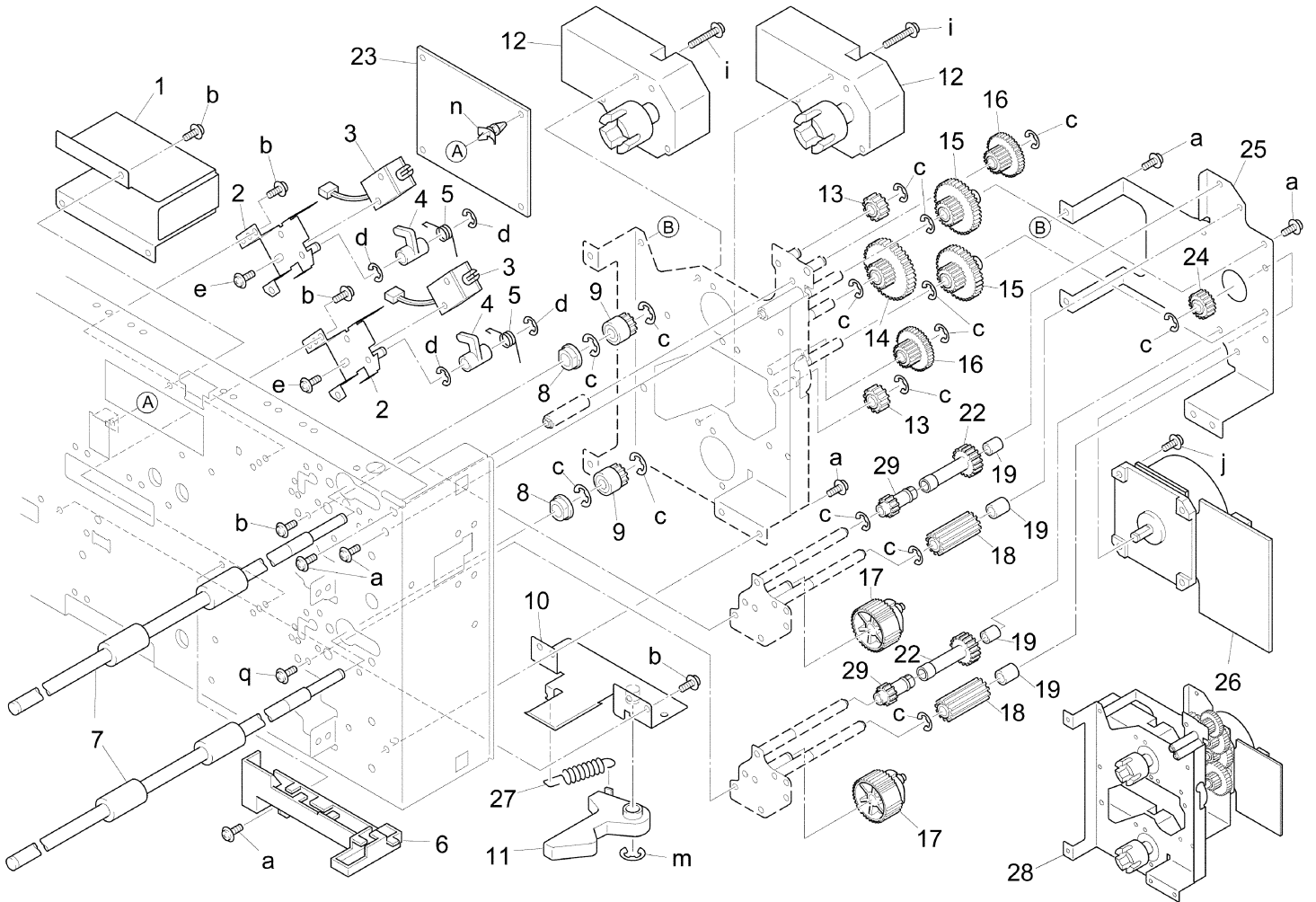

REF. NO.	PART NUMBER	DESCRIPTION
1	13HA10250	LCT sensor cover
2	13HA-1540	Solenoid mount plate assembly
3	26NA82510	Paper feed solenoid
4	26NA40830	Positioning arm
5	26NA40760	Lever hold spring
6	13HA10431	Wiring guide part/B
7	13HA40020	Paper feed connecting roller/3
8	26NA40820	Paper feed slide shaft holder
9	13HA77060	Driving gear (Z=15)
10	26NA-4780	Cassette lock assembly
11	25BA47461	Cassette positioning catch/U
12	26NA80041	Cassette driving motor
13	13HA77050	Idler gear/D (Z=17)
14	13HA77020	Idler gear/A (Z=19/44)
15	13HA77030	Idler gear/B (Z=19/40)
16	13HA77040	Idler gear/C (Z=16/31)
17	26NA-1680	Paper gear/2 assembly
18	13HA77080	Idler gear/F (Z=16)
19	13HA15110	Spacer
20	*	Not used
21	*	Not used
22	13HA77090	Paper feed coupling gear/A
23	13GU-9010	PFU driving board assembly
24	13HA77010	Motor gear (Z=18)
25	13HA15020	Driving panel/2
26	12RQ80010	Paper feed driving motor
27	26NA47390	Cassette fixed spring
28	13GU-1500	Driving assembly
29	26NA17490	Paper feed coupling gear/B

HARDWARE	
REF. LTR.	PART NUMBER
a	00Z193061
b	00Z283061
c	00Z670406
d	00Z670306
e	00Z163051
i	00Z193201
j	00Z184081
m	00Z670606
n	00Z925106
q	00Z183043



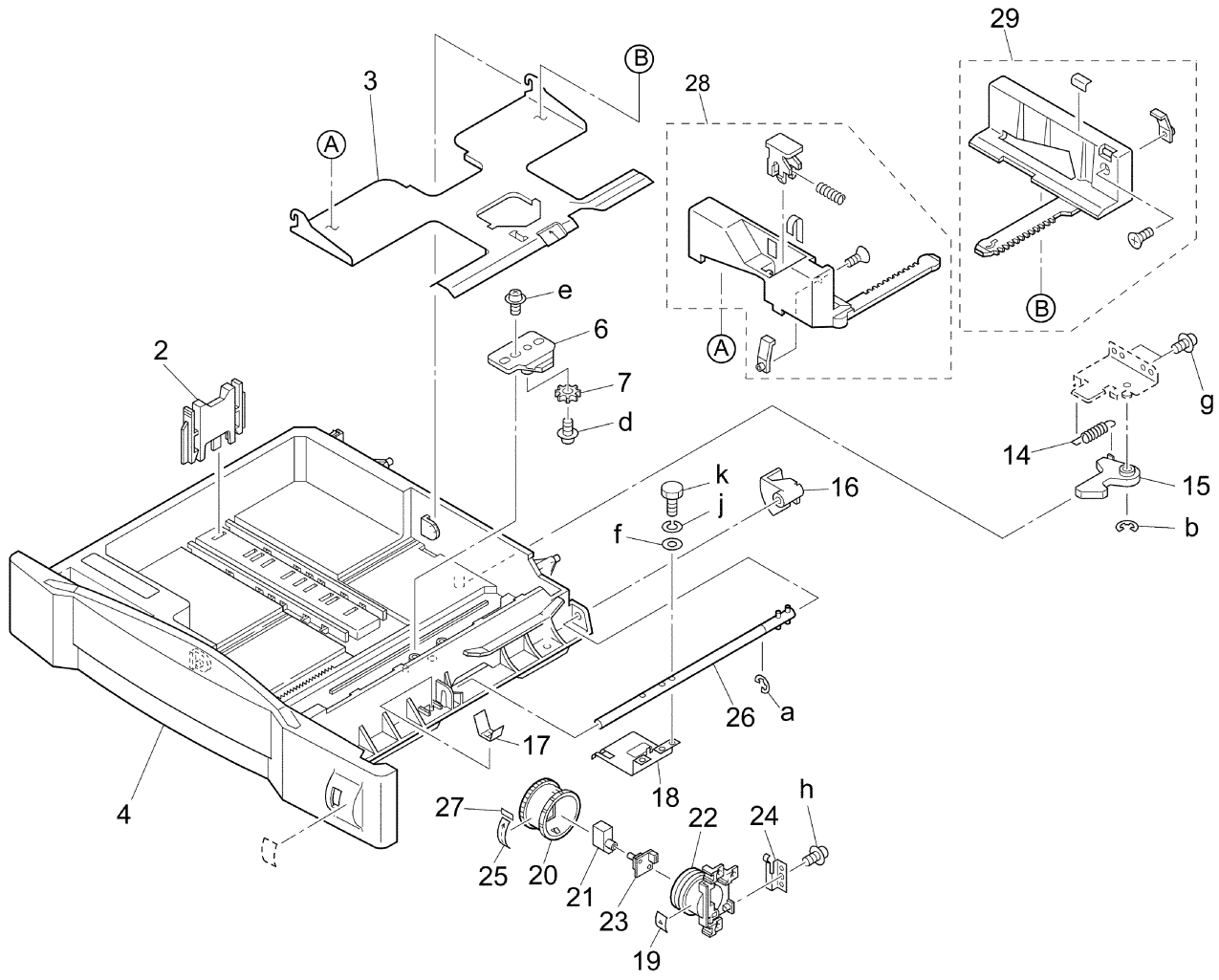

REF. NO.	PART NUMBER	DESCRIPTION
1	*	Not used
2	26NA47040	Paper feed regulating plate/Left
3	26NA-4740	Lift-up bottom plate assembly
4	26NA47023	Cassette base/Lower
5	*	Not used
6	40AA47130	Adjusting plate
7	40AA77290	Pinion (Z=16)
8	*	Not used
9	*	Not used
10	*	Not used
11	*	
12	*	Not used
13	*	Not used
14	26NA47390	Cassette fixed spring
15	25BA47461	Cassette positioning catch/U
16	26NA47291	Cassette remained detecting actuator
17	26NA47300	Ground plate
18	26NA47060	Paper lift-up plate
19	26NA97300	Cassette click label
20	26NA47260	Paper feed indicating plate/Front
21	26NA47240	Cassette detecting connector
22	26NA47250	Cassette detecting base
23	26NA-9200	Size detecting board assembly
24	26NA47280	Spring lock plate
25	26NE97290	Cassette indication label/Lower
26	26NA-4760	Lift-up shaft assembly
27	26NA47380	Fixing seal
28	26NA-4721	Side regulating plate/Front assembly
29	26NA-4730	Side regulating plate/Rear assembly

  

HARDWARE	
REF. LTR.	PART NUMBER
a	00Z670406
b	00Z670606
d	00Z254081
e	00Z254121
f	00Z610301
g	00Z283061
h	00Z253081
j	00Z463103
k	00Z620301

# Wiring

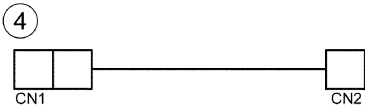
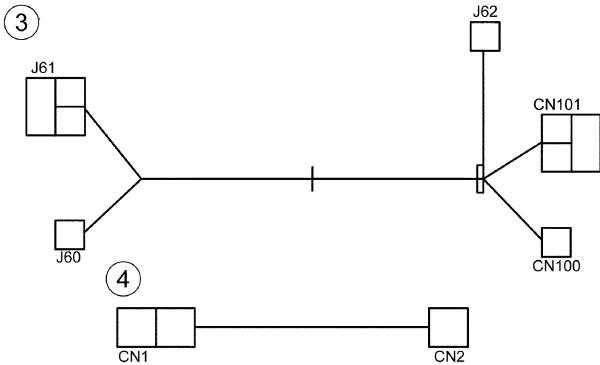
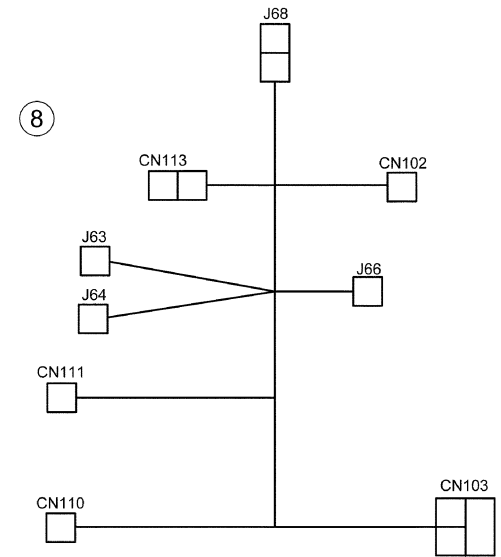
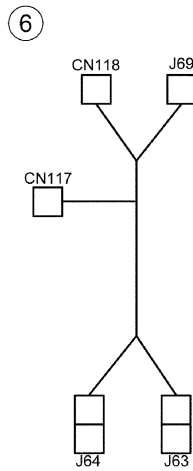
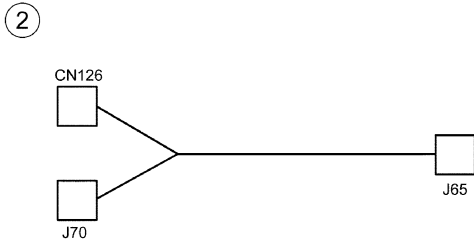
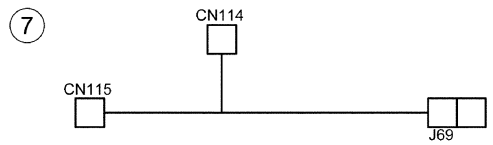
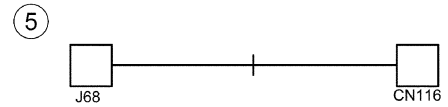
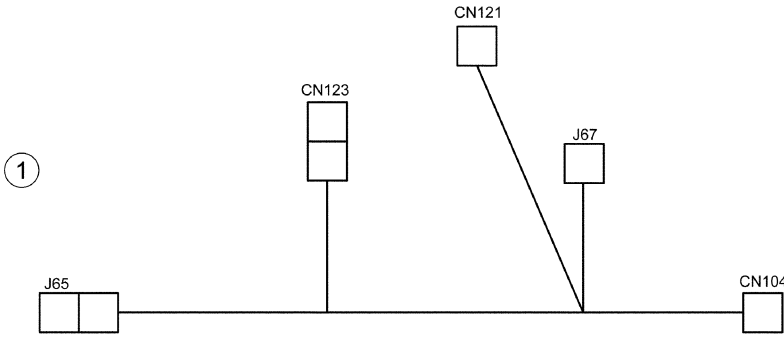

REF. NO.	PART NUMBER	DESCRIPTION
1	13GU90010	PFU wiring/1
2	13GU90020	PFU wiring/2
3	13HA90010	LCT electrify wiring
4	26NA90330	Sensor relay wiring/3
5	13HA90030	LCT wiring/2
6	13HA90040	LCT wiring/3
7	13HA90060	LCT wiring/5
8	13HA90020	LCT wiring/1

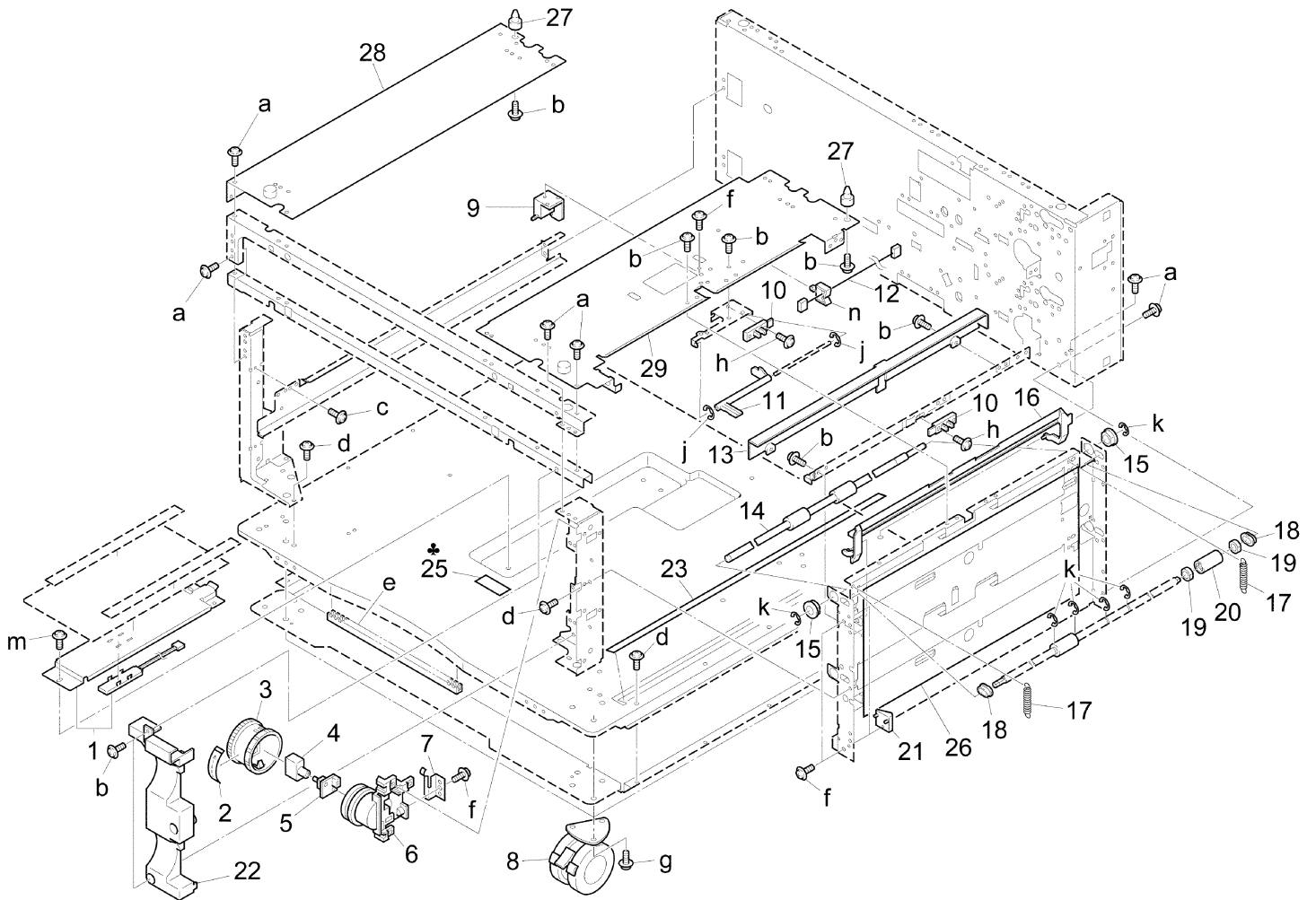

REF. NO.	PART NUMBER	DESCRIPTION
1	13HA-1121	Inner heater assembly
2	13HA-9720	Cassette label assembly
3	26NA47260	Paper feed indicating plate/Front
4	26NA47240	Cassette detecting connector
5	26NA-9200	Size detecting board assembly
6	26NA47250	Cassette detecting base
7	26NA47280	Spring lock plate
8	12XQ10040	Main support roller/A
9	13GU40110	Shaft holder part
10	552085510	Photosensor
11	13HA40060	Actuator/Upper
12	13HA90030	LCT wiring/2
13	13HA10390	Sensor cover
14	13HA40020	Paper feed connecting roller/3
15	26NA40820	Paper feed slide shaft holder
16	26NA40270	Side guide plate
17	13HA40070	Roller spring
18	13HA40150	Paper feed driven shaft holder
19	26NA40890	Slide bearing
20	26NA40680	Paper feed driven roller
21	13HA10420	Lock part/2
22	13HA12180	Cassette detecting cover
23	13HA10530	Guide sheet/2
24	*	Not used
25	55TE97110	High temperature caution label
26	13HA10540	Protection sheet
27	13HA10370	Main positioning shaft
28	13HA-1090	Main support plate left assembly
29	13HA-1070	Main support plate right assembly

HARDWARE	
REF. LTR.	PART NUMBER
a	00Z283061
b	00Z193061
c	00Z183061
d	00Z283081
e	00Z924316
f	00Z253081
g	00Z194101
h	00Z183121
j	00Z670206
k	00Z670606
m	00Z193041
n	00Z921941

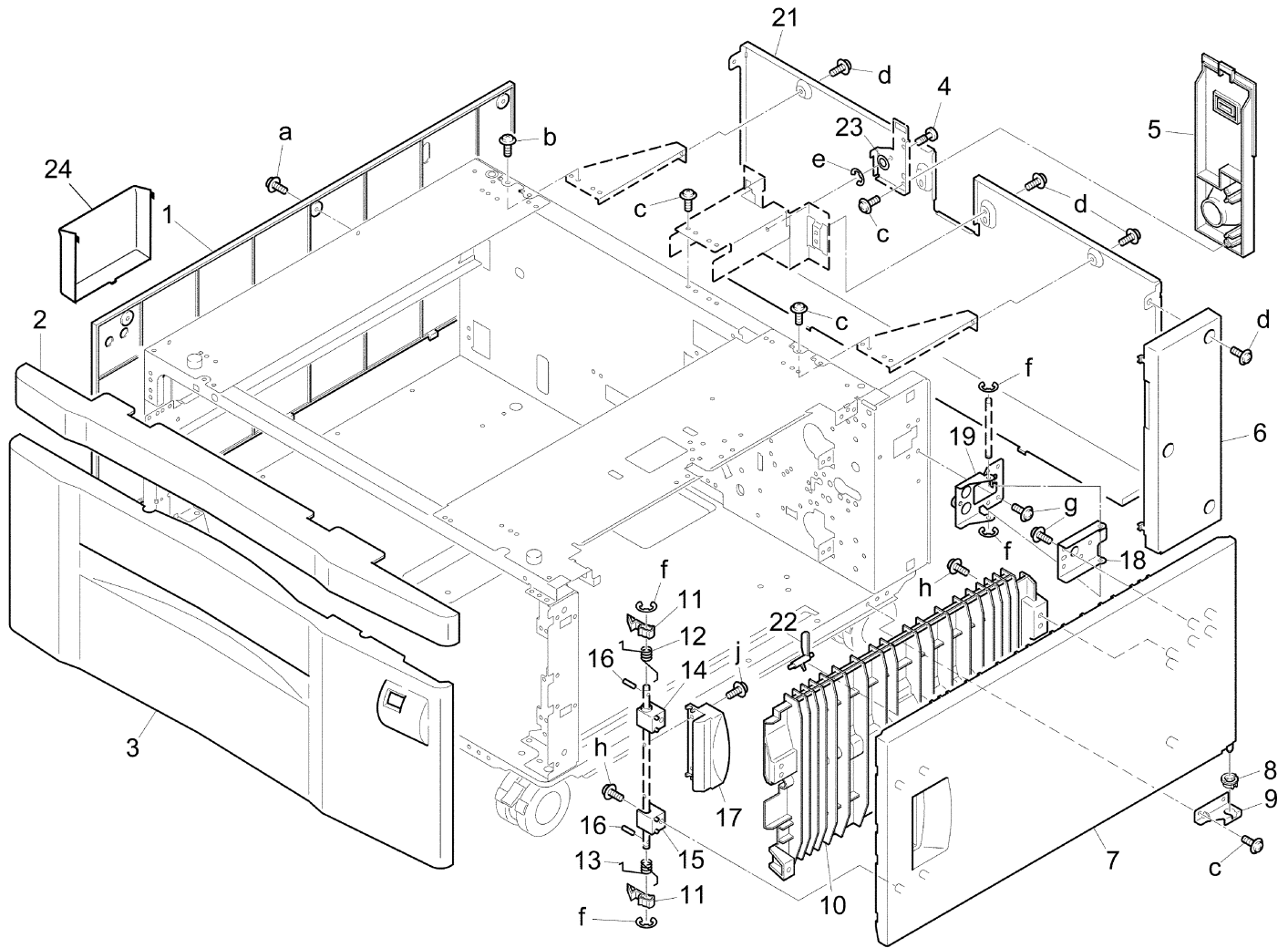

REF. NO.	PART NUMBER	DESCRIPTION
1	13HA12060	Fixed cover/Left
2	13HA12190	Front fixed cover
3	13HA12010	Front cover
4	26NA53931	Fixed screw
5	13HA12150	Cord cover
6	13HA12080	Side cover/Right
7	13HA12020	Door/Right
8	13HA10470	Door fulcrum part
9	13HA10460	Door fulcrum plate
10	13HA40080	Guide plate/Middle
11	26NA50080	Lock claw
12	13HA12160	Lock spring/Upper
13	13HA12170	Lock spring/Lower
14	26NA50630	Shaft holder part/Upper
15	26NA50640	Shaft holder part/Lower
16	466078010	Pin A
17	26NA50091	Open-close knob
18	13HA10340	Hinge plate/A
19	13HA-1260	Guide plate/B assembly
20	*	Not used
21	13HA12070	Rear cover
22	13HA10170	Actuator/Lower
23	13HA10550	Spacer/A
24	26NA12540	Accessories holding panel

HARDWARE	
REF. LTR.	PART NUMBER
a	00Z283081
b	00Z193061
c	00Z283061
d	00Z193062
e	00Z670256
f	00Z670306
g	00Z254081
h	00Z253081
j	00Z163101



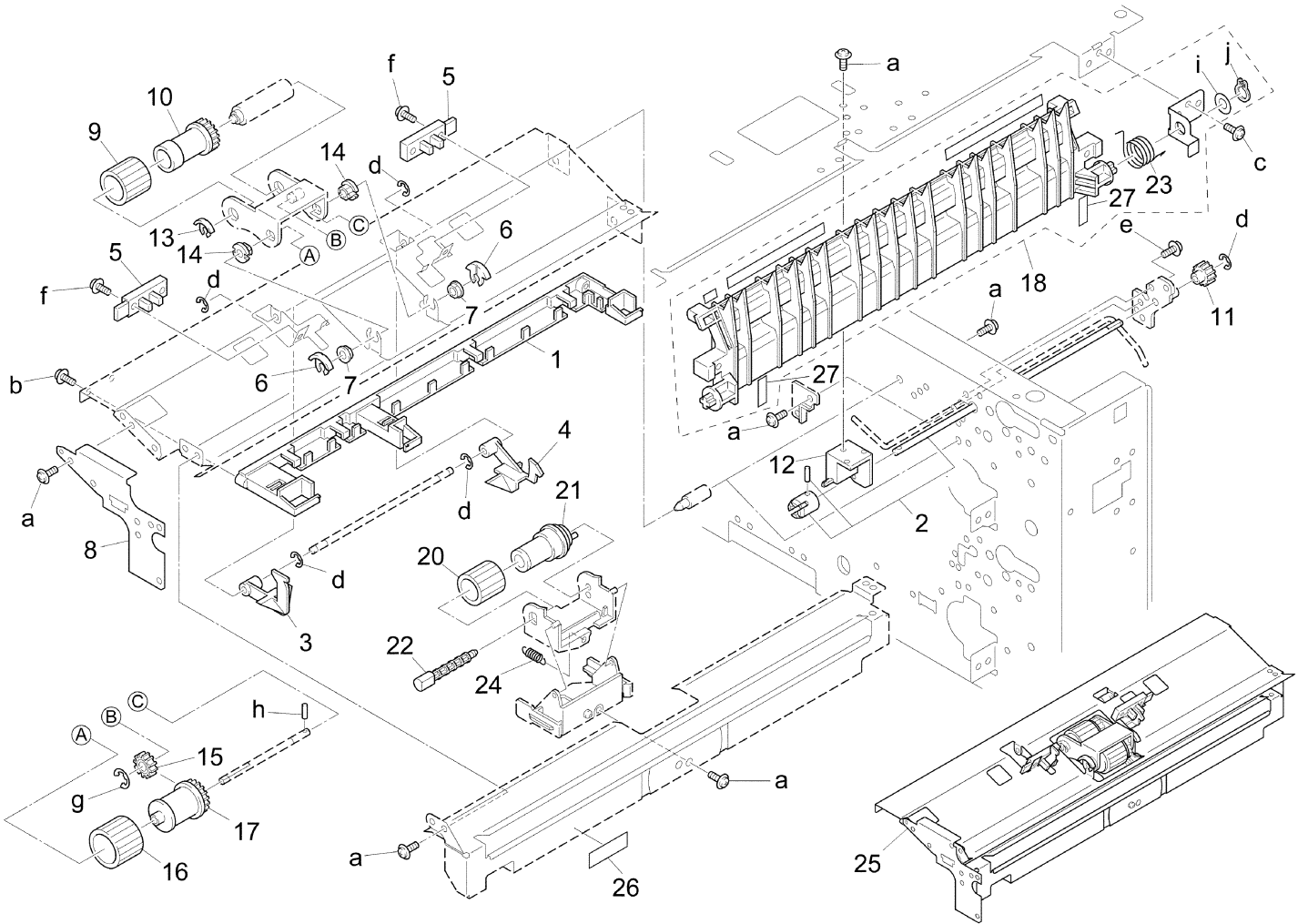

REF. NO.	PART NUMBER	DESCRIPTION
1	13HA40040	Wiring guide part
2	13HA-4040	Paper feed driving shaft/Rear
3	13HA40171	Paper detecting actuator/Front
4	13HA40160	Paper detecting actuator/Rear
5	552085510	Photosensor
6	26NA40700	Shaft positioning part
7	540076010	Paper feed shaft holder
8	13HA40030	Paper feed mount plate
9	26NA40090	Paper feeding rubber
10	26NA40080	Feeding roller
11	26NA16310	Paper feed gear (Z=15)
12	13GU40110	Shaft holder part
13	40AA40150	Shaft positioning part
14	40AA76040	Feeding shaft holder
15	26NA40510	Paper feed idler gear (Z=17)
16	26NA40110	Double feed preventive rubber/Upper
17	26NA40100	Double feed preventive roller/Upper
18	13HA-1131	Guide plate/Middle assembly
19	*	Not used
20	26NA40120	Double feed preventive roller/Lower
21	26NA40500	Double feed preventive roller
22	40AA40181	Lever click shaft
23	13HA10450	Paper feed rotary spring
24	40AA40450	Double feed pressure spring
25	13HA-4000	Paper feed assembly
26	13HA40180	Holder part
27	13HA10560	Guide sheet/3

HARDWARE	
REF. LTR.	PART NUMBER
a	00Z193061
b	00Z253081
c	00Z194061
d	00Z670306
e	00Z193051
f	00Z183121
g	00Z670406
h	00Z712106
i	00Z610501
j	00Z600506

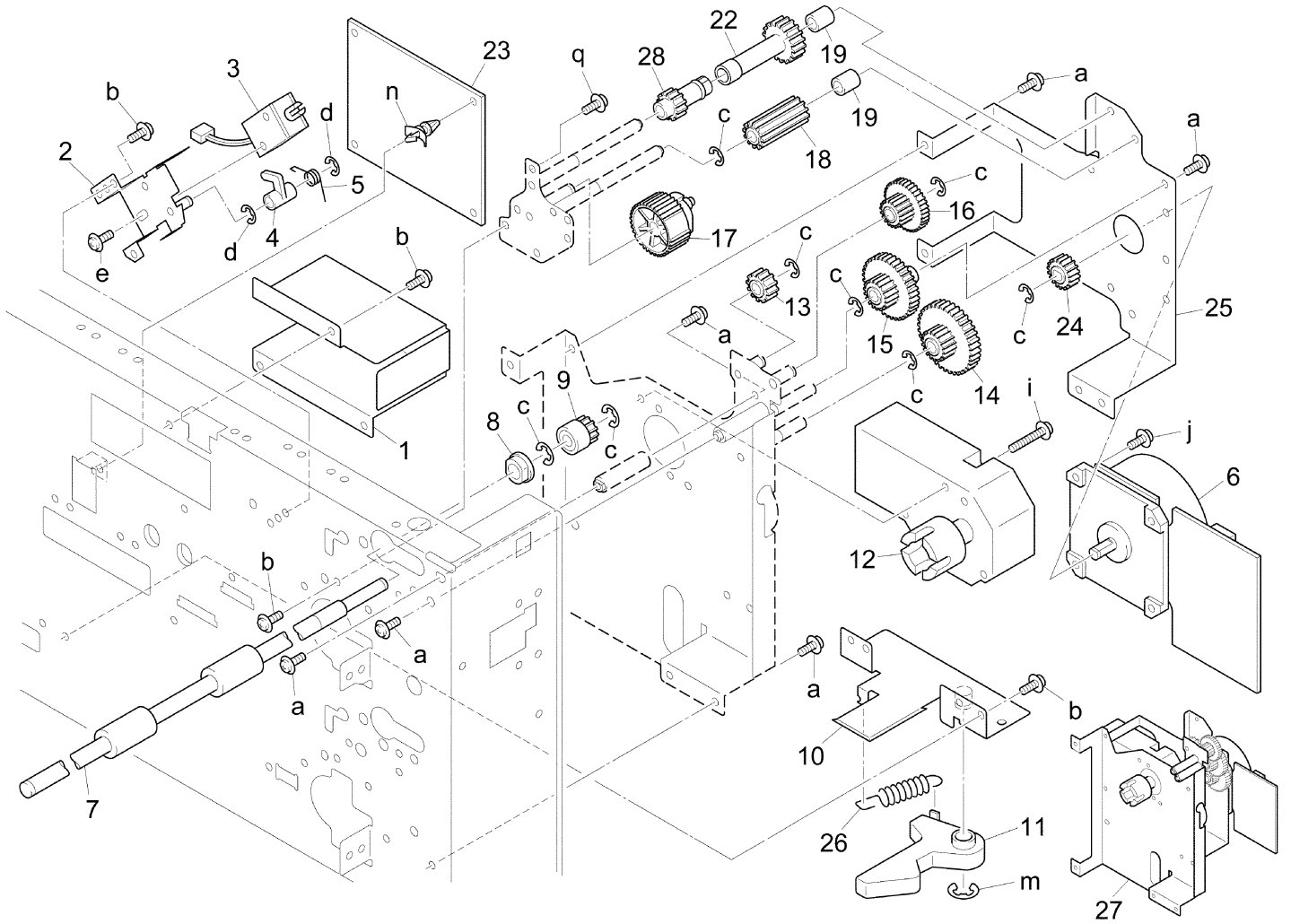

REF. NO.	PART NUMBER	DESCRIPTION
1	13HA10250	LCT sensor cover
2	13HA-1540	Solenoid mount plate assembly
3	26NA82510	Paper feed solenoid
4	26NA40830	Positioning arm
5	26NA40760	Lever hold spring
6	12RQ80010	Paper feed driving motor
7	13HA40020	Paper feed connecting roller/3
8	26NA40820	Paper feed slide shaft holder
9	13HA77060	Driving gear (Z=15)
10	13HA-4780	LCT lock plate assembly
11	25BA47461	Cassette positioning cam/U
12	13HA80020	LCT driving motor
13	13HA77050	Idler gear/D (Z=17)
14	13HA77020	Idler gear/A (Z=19/44)
15	13HA77030	Idler gear/B (Z=19/40)
16	13HA77040	Idler gear/C (Z=16/31)
17	26NA-1680	Paper gear/2 assembly
18	13HA77080	Idler gear/F (Z=16)
19	13HA15110	Spacer
20	*	Not used
21	*	Not used
22	13HA77090	Paper feed coupling gear/A
23	13HA-9010	LCT driving board assembly
24	13HA77010	Motor gear (Z=18)
25	13HA15020	Driving panel/2
26	26NA47390	Cassette fixed spring
27	13HA-1500	Driving assembly
28	26NA17490	Paper feed coupling gear/B

HARDWARE	
REF. LTR.	PART NUMBER
a	00Z193061
b	00Z283061
c	00Z670406
d	00Z670306
e	00Z163051
i	00Z193301
j	00Z184081
m	00Z670606
n	00Z925106
q	00Z183043

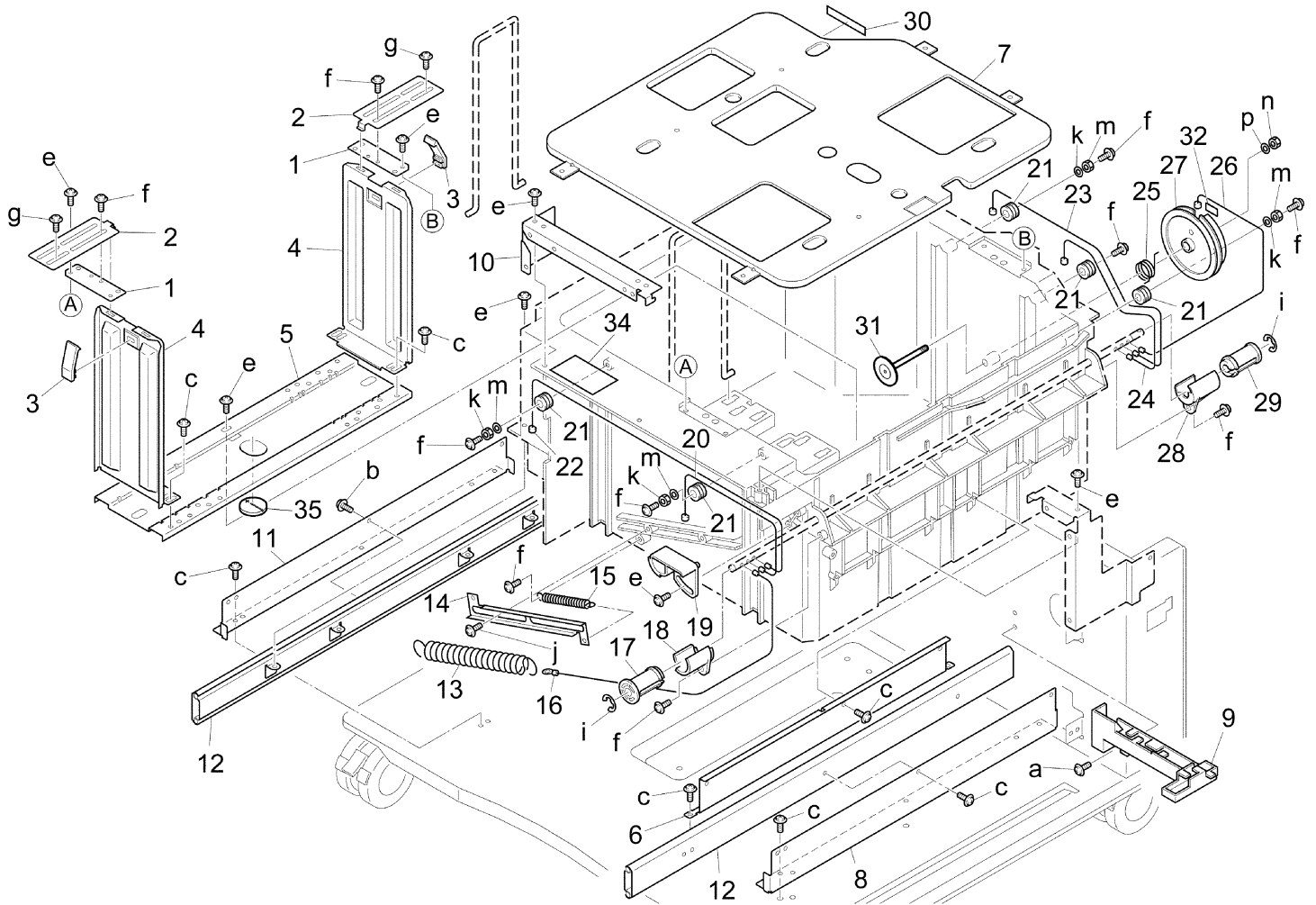

REF. NO.	PART NUMBER	DESCRIPTION
1	13HA47270	Fixed plate
2	13HA47250	Reinforcing plate
3	540047200	Paper regulating claw
4	13HA47280	Paper guide plate
5	12RQ47030	Paper adjusting plate
6	13HA47170	Main mount plate/Right
7	12RQ47020	Paper guide plate
8	13HA10130	Rail mount plate/Right
9	13HA10431	Wiring guide part/B
10	13HA12130	External mount plate/3
11	13HA10140	Rail mount plate/Left
12	13HA10161	LCT slide rail
13	13HA47140	Driving auxiliary spring/A
14	564047230	Spring mount plate
15	13HA47150	Driving auxiliary spring/B
16	12RQ47160	Auxiliary wire
17	12RQ47090	Wire driving pulley/Front
18	12RQ47110	Pulley fixed part/Front
19	12RQ47230	Wire adjusting part
20	13HA47100	Lift-up wire/1
21	13HA47210	Wire pulley
22	13HA47110	Lift-up wire/2
23	13HA47220	Lift-up wire/4
24	13HA47120	Lift-up wire/3
25	13HA47190	Detecting spring
26	13HA47130	Detecting wire
27	13HA47090	Detecting plate
28	13HA47260	Pulley fixed part/Rear
29	13HA47370	Driving pulley
30	13HA47330	Slide sheet
31	13HA-4790	Fulcrum shaft assembly
32	13HA47340	Paper guide sheet/1
33	*	Not used
34	13HA97050	LCT guide label
35	13HA47380	Adjusting cam

HARDWARE	
REF. LTR.	PART NUMBER
a	00Z193061
b	00Z193051
c	00Z283061
e	00Z254081
f	00Z183201
g	00Z163081
i	00Z670406
j	00Z193041
k	00Z610321
m	00Z510301
n	00Z610421
p	00Z510401

# Wiring

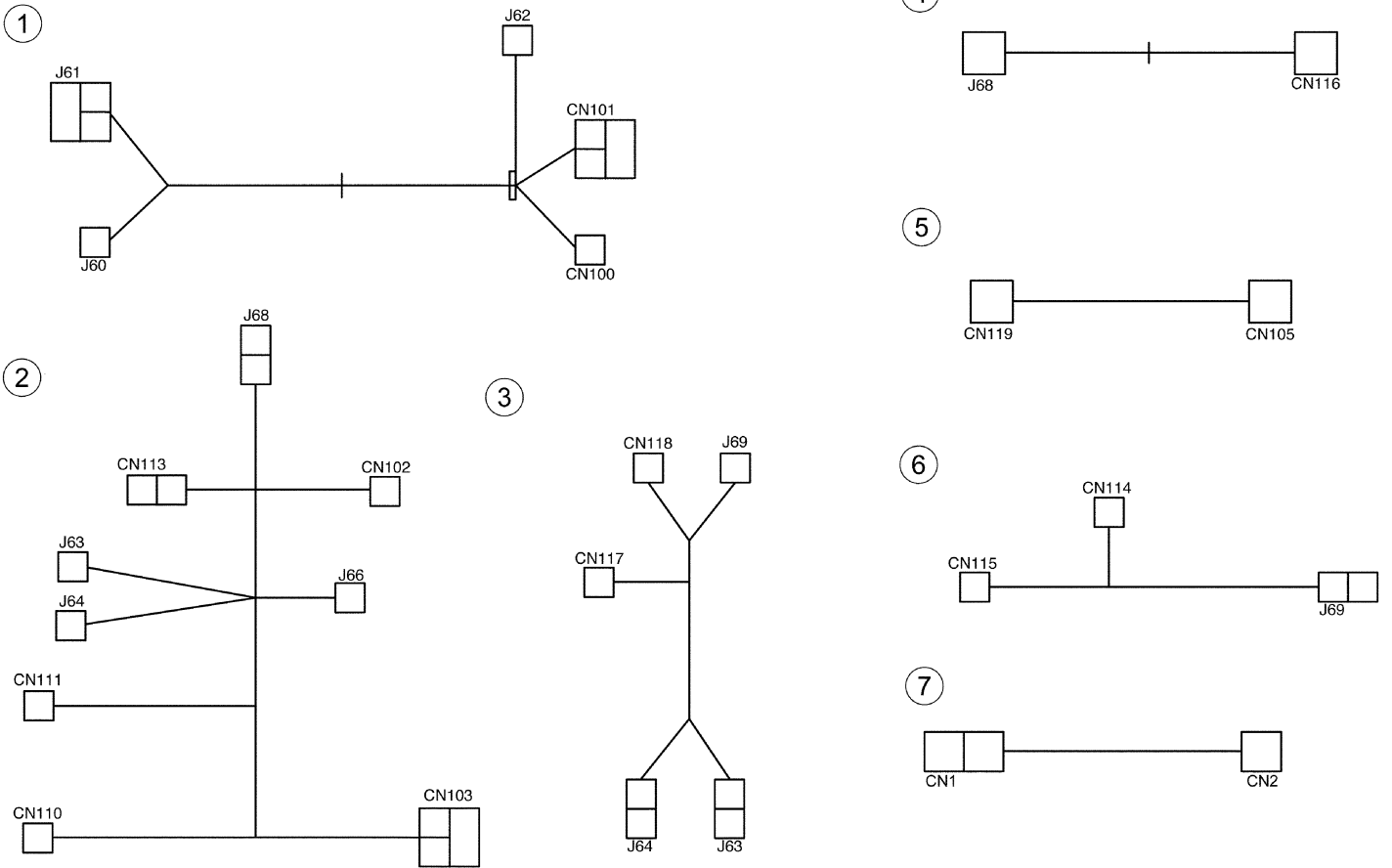

REF. NO.	PART NUMBER	DESCRIPTION
1	13HA90010	LCT electrify wiring
2	13HA90020	LCT wiring/1
3	13HA90040	LCT wiring/3
4	13HA90030	LCT wiring/2
5	13HA90050	LCT wiring/4
6	13HA90060	LCT wiring/5
7	26NA90330	Sensor relay wiring/3

This page left blank intentionally.



## Alphabetical index

PART DESCRIPTION	PAGE NO.	REF. NO.	PART DESCRIPTION	PAGE NO.	REF. NO.	PART DESCRIPTION	PAGE NO.	REF. NO.
<b>A</b>						<b>I</b>		
Accessories holding panel . . . . .	5	24	Double feed preventive rubber/Upper . . . . .	7	16	Idler gear/A (Z=19/44) . . . . .	9	14
Accessories holding panel . . . . .	17	24	Double feed preventive rubber/Lower . . . . .	7	20	Idler gear/A (Z=19/44) . . . . .	21	14
Actuator/Lower . . . . .	5	21	Double feed preventive rubber/Upper . . . . .	19	16	Idler gear/B (Z=19/40) . . . . .	21	15
Actuator/Lower . . . . .	17	22	Driven spring . . . . .	3	7	Idler gear/C (Z=16/31) . . . . .	9	16
Actuator/Upper . . . . .	3	6	Driving assembly . . . . .	9	28	Idler gear/C (Z=16/31) . . . . .	21	16
Actuator/Upper . . . . .	15	11	Driving assembly . . . . .	21	27	Idler gear/D (Z=17) . . . . .	9	13
Adjusting cam . . . . .	23	35	Driving auxiliary spring/A . . . . .	23	13	Idler gear/D (Z=17) . . . . .	21	13
Adjusting plate . . . . .	11	6	Driving auxiliary spring/B . . . . .	23	15	Idler gear/F (Z=16) . . . . .	9	18
Auxiliary wire . . . . .	23	16	Driving gear (Z=15) . . . . .	9	9	Idler gear/F (Z=16) . . . . .	21	18
<b>C</b>			Driving gear (Z=15) . . . . .	21	9	Inner heater assembly . . . . .	3	2
Cassette base/Lower . . . . .	11	4	Driving panel/2 . . . . .	9	25	Inner heater assembly . . . . .	15	1
Cassette click label . . . . .	11	19	Driving panel/2 . . . . .	21	25	<b>L</b>		
Cassette detecting base . . . . .	11	22	Driving pulley . . . . .	23	29	LCT driving board assembly . . . . .	21	23
Cassette detecting base . . . . .	15	6	<b>E</b>			LCT driving motor . . . . .	21	12
Cassette detecting connector . . . . .	11	21	External mount plate/3 . . . . .	23	10	LCT electrify wiring . . . . .	13	3
Cassette detecting connector . . . . .	15	4	<b>F</b>			LCT electrify wiring . . . . .	25	1
Cassette detecting cover . . . . .	3	3	Feeding roller . . . . .	7	10	LCT guide label . . . . .	23	34
Cassette detecting cover . . . . .	15	22	Feeding roller . . . . .	19	10	LCT lock plate assembly . . . . .	21	10
Cassette driving motor . . . . .	9	12	Feeding shaft holder . . . . .	7	14	LCT sensor cover . . . . .	9	1
Cassette fixed spring . . . . .	9	27	Feeding shaft holder . . . . .	19	14	LCT sensor cover . . . . .	21	1
Cassette fixed spring . . . . .	11	14	Fixed cover/Left . . . . .	17	1	LCT slide rail . . . . .	23	12
Cassette fixed spring . . . . .	21	26	Fixed plate . . . . .	23	1	LCT wiring/1 . . . . .	13	8
Cassette indication label/Lower . . . . .	11	25	Fixed plate . . . . .	5	3	LCT wiring/1 . . . . .	25	2
Cassette label assembly . . . . .	15	2	Fixed screw . . . . .	17	4	LCT wiring/2 . . . . .	3	9
Cassette lock assembly . . . . .	9	10	Fixed screw . . . . .	11	27	LCT wiring/2 . . . . .	13	5
Cassette positioning cam/U . . . . .	21	11	Fixing seal . . . . .	11	27	LCT wiring/2 . . . . .	15	12
Cassette positioning catch/U . . . . .	9	11	Front cover . . . . .	17	3	LCT wiring/2 . . . . .	25	4
Cassette positioning catch/U . . . . .	11	15	Front fixed cover . . . . .	5	2	LCT wiring/3 . . . . .	13	6
Cassette rail/Right . . . . .	5	20	Front fixed cover . . . . .	17	2	LCT wiring/3 . . . . .	25	3
Cassette remained detecting actuator . . . . .	11	16	Fulcrum shaft assembly . . . . .	23	31	LCT wiring/4 . . . . .	25	5
Cassette stopper . . . . .	3	1	<b>G</b>			LCT wiring/5 . . . . .	13	7
Cord cover . . . . .	5	4	Ground plate . . . . .	11	17	LCT wiring/5 . . . . .	25	6
Cord cover . . . . .	17	5	Guide plate/B assembly . . . . .	5	18	Lever click shaft . . . . .	7	22
<b>D</b>			Guide plate/B assembly . . . . .	17	19	Lever click shaft . . . . .	19	22
Detecting plate . . . . .	23	27	Guide plate/Middle . . . . .	5	9	Lever hold spring . . . . .	9	5
Detecting spring . . . . .	23	25	Guide plate/Middle . . . . .	17	10	Lever hold spring . . . . .	21	5
Detecting wire . . . . .	23	26	Guide plate/Middle assembly . . . . .	7	26	Lift-up bottom plate assembly . . . . .	11	3
Door fulcrum part . . . . .	5	7	Guide plate/Middle assembly . . . . .	19	18	Lift-up shaft assembly . . . . .	11	26
Door fulcrum part . . . . .	17	8	Guide sheet/2 . . . . .	3	17	Lift-up wire/1 . . . . .	23	20
Door fulcrum plate . . . . .	5	8	Guide sheet/2 . . . . .	15	23	Lift-up wire/2 . . . . .	23	22
Door fulcrum plate . . . . .	17	9	Guide sheet/3 . . . . .	7	28	Lift-up wire/3 . . . . .	23	24
Door/Right . . . . .	5	6	Guide sheet/3 . . . . .	19	27	Lift-up wire/4 . . . . .	23	23
Door/Right . . . . .	17	7	<b>H</b>			Lock claw . . . . .	5	11
Double feed pressure spring . . . . .	7	24	High temperature caution label . . . . .	15	25	Lock claw . . . . .	17	11
Double feed pressure spring . . . . .	19	24	Hinge plate/A . . . . .	5	17	Lock part . . . . .	3	13
Double feed preventive roller . . . . .	7	21	Hinge plate/A . . . . .	17	18	Lock part/2 . . . . .	15	21
Double feed preventive roller . . . . .	19	21	Holder part . . . . .	7	27	Lock spring/Lower . . . . .	5	13
Double feed preventive roller/Upper . . . . .	7	17	Holder part . . . . .	19	26	Lock spring/Lower . . . . .	17	13
Double feed preventive roller/Upper . . . . .	19	17	<b>M</b>			Lock spring/Upper . . . . .	5	12
Double feed preventive roller/Lower . . . . .	19	20	Main mount plate/Right . . . . .	23	6	Lock spring/Upper . . . . .	17	12
			Main positioning shaft . . . . .	3	18			
			Main positioning shaft . . . . .	15	27			

PART DESCRIPTION	PAGE NO.	REF. NO.	PART DESCRIPTION	PAGE NO.	REF. NO.	PART DESCRIPTION	PAGE NO.	REF. NO.		
Main support plate left assembly . . . . .	3	19	Paper feed gear (Z=15) . . .	19	11	<b>S</b>				
Main support plate left assembly . . . . .	15	28	Paper feed idler gear (Z=17)	7	15		Sensor cover . . . . .	15	13	
Main support plate right assembly . . . . .	3	20	Paper feed idler gear (Z=17)	19	15		Sensor relay wiring/3 . . . . .	13	4	
Main support plate right assembly . . . . .	15	29	Paper feed indicating plate/Fr	11	20		Sensor relay wiring/3 . . . . .	25	7	
Main support roller/A . . . . .	3	4	Paper feed indicating plate/Fr	15	3		Shaft holder mount plate . . .	7	25	
Main support roller/A . . . . .	15	8	Paper feed mount plate . . .	7	8		Shaft holder part . . . . .	3	8	
Motor gear (Z=18) . . . . .	9	24	Paper feed mount plate . . .	19	8		Shaft holder part . . . . .	7	12	
Motor gear (Z=18) . . . . .	21	24	Paper feed regulating plate/Left . . . . .	11	2		Shaft holder part . . . . .	15	9	
<b>O</b>			Paper feed rotary spring . . .	7	23		Shaft holder part . . . . .	19	12	
	Open-close knob . . . . .	5	10	Paper feed rotary spring . . .	19		23	Shaft holder part/Lower . . . .	5	15
	Open-close knob . . . . .	17	17	Paper feed shaft holder . . . .	7		7	Shaft holder part/Lower . . . .	17	15
				Paper feed shaft holder . . . .	19		7	Shaft holder part/Upper . . . .	5	14
				Paper feed shaft/Rear assembly . . . . .	7		2	Shaft holder part/Upper . . . .	17	14
				Paper feed slide shaft holder . . .	3		11	Shaft positioning part . . . . .	7	6
				Paper feed slide shaft holder . . .	9		8	Shaft positioning part . . . . .	7	13
				Paper feed slide shaft holder . . .	15		15	Shaft positioning part . . . . .	19	6
				Paper feed solenoid . . . . .	21		8	Shaft positioning part . . . . .	19	13
				Paper feed solenoid . . . . .	9		3	Side cover/Left . . . . .	5	1
			Paper feed solenoid . . . . .	21	3		Side cover/Right . . . . .	5	5	
<b>P</b>			Paper feeding rubber . . . . .	7	9		Side cover/Right . . . . .	17	6	
	PFU driving board assembly . . . . .	9	23	Paper feeding rubber . . . . .	19		9	Side guide plate . . . . .	3	12
	PFU wiring/1 . . . . .	13	1	Paper feeding rubber . . . . .	19		9	Side guide plate . . . . .	15	16
	PFU wiring/2 . . . . .	13	2	Paper gear/2 assembly . . . . .	9		17	Side regulating plate/Front assembly . . . . .	11	28
	Paper adjusting plate . . . . .	23	5	Paper gear/2 assembly . . . . .	21	17	Side regulating plate/Rear assembly . . . . .	11	29	
	Paper detecting actuator . . . . .	7	3	Paper guide plate . . . . .	23	4	Size detecting board assembly . . . . .	11	23	
	Paper detecting actuator/2 . . . . .	7	4	Paper guide plate . . . . .	23	7	Size detecting board assembly . . . . .	15	5	
	Paper detecting actuator/Front . . . . .	19	3	Paper guide sheet/1 . . . . .	23	32	Slide bearing . . . . .	3	15	
	Paper detecting actuator/Rear . . . . .	19	4	Paper lift-up plate . . . . .	11	18	Slide bearing . . . . .	15	19	
	Paper feed assembly . . . . .	19	25	Paper regulating claw . . . . .	23	3	Slide sheet . . . . .	23	30	
Paper feed connecting roller/3 . . . . .	3	10	Photosensor . . . . .	3	5	Solenoid mount plate assembly . . . . .	9	2		
Paper feed connecting roller/3 . . . . .	9	7	Photosensor . . . . .	7	5	Solenoid mount plate assembly . . . . .	21	2		
Paper feed connecting roller/3 . . . . .	15	14	Photosensor . . . . .	15	10	Spacer . . . . .	9	19		
Paper feed connecting roller/3 . . . . .	21	7	Photosensor . . . . .	19	5	Spacer . . . . .	21	19		
Paper feed coupling gear/A . . . . .	9	22	Pin A . . . . .	5	16	Spacer/A . . . . .	5	23		
Paper feed coupling gear/A . . . . .	21	22	Pin A . . . . .	17	16	Spacer/A . . . . .	17	23		
Paper feed coupling gear/B . . . . .	9	29	Pinion (Z=16) . . . . .	11	7	Spring lock plate . . . . .	11	24		
Paper feed coupling gear/B . . . . .	21	28	Positioning arm . . . . .	9	4	Spring lock plate . . . . .	15	7		
Paper feed driven roller . . . . .	15	20	Positioning arm . . . . .	21	4	Spring mount plate . . . . .	23	14		
Paper feed driven roller/Lower . . . . .	3	16	Protection sheet . . . . .	15	26					
Paper feed driven shaft holder . . . . .	3	14	Pulley fixed part/Front . . . . .	23	18	<b>W</b>				
Paper feed driven shaft holder . . . . .	15	18	Pulley fixed part/Rear . . . . .	23	28		Wire adjusting part . . . . .	23	19	
Paper feed driving motor . . . . .	9	26	<b>R</b>				Wire driving pulley/Front . . .	23	17	
Paper feed driving motor . . . . .	21	6		Rail mount plate/Left . . . . .	23		11	Wire pulley . . . . .	23	21
Paper feed driving shaft/Rear . . . . .	19	2		Rail mount plate/Right . . . . .	23		8	Wiring guide part . . . . .	7	1
Paper feed gear (Z=15) . . . . .	7	11		Rear cover . . . . .	5		22	Wiring guide part . . . . .	19	1
				Rear cover . . . . .	17		21	Wiring guide part/B . . . . .	9	6
				Reinforcing plate . . . . .	23		2	Wiring guide part/B . . . . .	23	9
				Roller spring . . . . .	15		17			

## Numerical index

PART NUMBER	PAGE NO.	REF. NO.	PART NUMBER	PAGE NO.	REF. NO.	PART NUMBER	PAGE NO.	REF. NO.
12RQ47020 . . . .	23	7	13HA10530 . . . .	15	23	13HA47340 . . . .	23	32
12RQ47030 . . . .	23	5	13HA10540 . . . .	15	26	13HA47370 . . . .	23	29
12RQ47090 . . . .	23	17	13HA10550 . . . .	5	23	13HA47380 . . . .	23	35
12RQ47110 . . . .	23	18	13HA10550 . . . .	17	23	13HA77010 . . . .	9	24
12RQ47160 . . . .	23	16	13HA10560 . . . .	7	28	13HA77010 . . . .	21	24
12RQ47230 . . . .	23	19	13HA10560 . . . .	19	27	13HA77020 . . . .	9	14
12RQ80010 . . . .	9	26	13HA12010 . . . .	17	3	13HA77020 . . . .	21	14
12RQ80010 . . . .	21	6	13HA12020 . . . .	5	6	13HA77030 . . . .	9	15
12XQ10040 . . . .	3	4	13HA12020 . . . .	17	7	13HA77030 . . . .	21	15
12XQ10040 . . . .	15	8	13HA12060 . . . .	5	1	13HA77040 . . . .	9	16
13GU-1500 . . . .	9	28	13HA12060 . . . .	17	1	13HA77040 . . . .	21	16
13GU-9010 . . . .	9	23	13HA12070 . . . .	5	22	13HA77050 . . . .	9	13
13GU12040 . . . .	5	2	13HA12070 . . . .	17	21	13HA77050 . . . .	21	13
13GU12050 . . . .	3	3	13HA12080 . . . .	5	5	13HA77060 . . . .	9	9
13GU40100 . . . .	7	25	13HA12080 . . . .	17	6	13HA77060 . . . .	21	9
13GU40110 . . . .	3	8	13HA12130 . . . .	23	10	13HA77080 . . . .	9	18
13GU40110 . . . .	7	12	13HA12150 . . . .	5	4	13HA77080 . . . .	21	18
13GU40110 . . . .	15	9	13HA12150 . . . .	17	5	13HA77090 . . . .	9	22
13GU40110 . . . .	19	12	13HA12160 . . . .	5	12	13HA77090 . . . .	21	22
13GU90010 . . . .	13	1	13HA12160 . . . .	17	12	13HA80020 . . . .	21	12
13GU90020 . . . .	13	2	13HA12170 . . . .	5	13	13HA90010 . . . .	13	3
13HA-1070 . . . .	3	20	13HA12170 . . . .	17	13	13HA90010 . . . .	25	1
13HA-1070 . . . .	15	29	13HA12180 . . . .	15	22	13HA90020 . . . .	13	8
13HA-1090 . . . .	3	19	13HA12190 . . . .	17	2	13HA90020 . . . .	25	2
13HA-1090 . . . .	15	28	13HA15020 . . . .	9	25	13HA90030 . . . .	3	9
13HA-1121 . . . .	3	2	13HA15020 . . . .	21	25	13HA90030 . . . .	13	5
13HA-1121 . . . .	15	1	13HA15110 . . . .	9	19	13HA90030 . . . .	15	12
13HA-1131 . . . .	7	26	13HA15110 . . . .	21	19	13HA90030 . . . .	25	4
13HA-1131 . . . .	19	18	13HA40020 . . . .	3	10	13HA90040 . . . .	13	6
13HA-1260 . . . .	5	18	13HA40020 . . . .	9	7	13HA90040 . . . .	25	3
13HA-1260 . . . .	17	19	13HA40020 . . . .	15	14	13HA90050 . . . .	25	5
13HA-1500 . . . .	21	27	13HA40020 . . . .	21	7	13HA90060 . . . .	13	7
13HA-1540 . . . .	9	2	13HA40030 . . . .	7	8	13HA90060 . . . .	25	6
13HA-1540 . . . .	21	2	13HA40030 . . . .	19	8	13HA97050 . . . .	23	34
13HA-4000 . . . .	19	25	13HA40040 . . . .	7	1	25BA47461 . . . .	9	11
13HA-4040 . . . .	7	2	13HA40040 . . . .	19	1	25BA47461 . . . .	11	15
13HA-4040 . . . .	19	2	13HA40060 . . . .	3	6	25BA47461 . . . .	21	11
13HA-4780 . . . .	21	10	13HA40060 . . . .	15	11	26NA-1680 . . . .	9	17
13HA-4790 . . . .	23	31	13HA40070 . . . .	3	7	26NA-1680 . . . .	21	17
13HA-9010 . . . .	21	23	13HA40070 . . . .	15	17	26NA-4721 . . . .	11	28
13HA-9720 . . . .	15	2	13HA40080 . . . .	5	9	26NA-4730 . . . .	11	29
13HA10130 . . . .	23	8	13HA40080 . . . .	17	10	26NA-4740 . . . .	11	3
13HA10140 . . . .	23	11	13HA40150 . . . .	3	14	26NA-4760 . . . .	11	26
13HA10161 . . . .	23	12	13HA40150 . . . .	15	18	26NA-4780 . . . .	9	10
13HA10170 . . . .	5	21	13HA40160 . . . .	19	4	26NA-9200 . . . .	11	23
13HA10170 . . . .	17	22	13HA40171 . . . .	19	3	26NA-9200 . . . .	15	5
13HA10250 . . . .	9	1	13HA40180 . . . .	7	27	26NA10061 . . . .	5	20
13HA10250 . . . .	21	1	13HA40180 . . . .	19	26	26NA12540 . . . .	5	24
13HA10340 . . . .	5	17	13HA47090 . . . .	23	27	26NA12540 . . . .	17	24
13HA10340 . . . .	17	18	13HA47100 . . . .	23	20	26NA16310 . . . .	7	11
13HA10370 . . . .	3	18	13HA47110 . . . .	23	22	26NA16310 . . . .	19	11
13HA10370 . . . .	15	27	13HA47120 . . . .	23	24	26NA17490 . . . .	9	29
13HA10390 . . . .	15	13	13HA47130 . . . .	23	26	26NA17490 . . . .	21	28
13HA10420 . . . .	3	13	13HA47140 . . . .	23	13	26NA40080 . . . .	7	10
13HA10420 . . . .	15	21	13HA47150 . . . .	23	15	26NA40080 . . . .	19	10
13HA10431 . . . .	9	6	13HA47170 . . . .	23	6	26NA40090 . . . .	7	9
13HA10431 . . . .	23	9	13HA47190 . . . .	23	25	26NA40090 . . . .	19	9
13HA10450 . . . .	7	23	13HA47210 . . . .	23	21	26NA40100 . . . .	7	17
13HA10450 . . . .	19	23	13HA47220 . . . .	23	23	26NA40100 . . . .	19	17
13HA10460 . . . .	5	8	13HA47250 . . . .	23	2	26NA40110 . . . .	7	16
13HA10460 . . . .	17	9	13HA47260 . . . .	23	28	26NA40110 . . . .	19	16
13HA10470 . . . .	5	7	13HA47270 . . . .	23	1	26NA40120 . . . .	7	20
13HA10470 . . . .	17	8	13HA47280 . . . .	23	4	26NA40120 . . . .	19	20
13HA10530 . . . .	3	17	13HA47330 . . . .	23	30	26NA40270 . . . .	3	12

PART NUMBER	PAGE NO.	REF. NO.
26NA40270 . . . . .	15	16
26NA40280 . . . . .	7	3
26NA40500 . . . . .	7	21
26NA40500 . . . . .	19	21
26NA40510 . . . . .	7	15
26NA40510 . . . . .	19	15
26NA40680 . . . . .	3	16
26NA40680 . . . . .	15	20
26NA40700 . . . . .	7	6
26NA40700 . . . . .	19	6
26NA40750 . . . . .	7	4
26NA40760 . . . . .	9	5
26NA40760 . . . . .	21	5
26NA40820 . . . . .	3	11
26NA40820 . . . . .	9	8
26NA40820 . . . . .	15	15
26NA40820 . . . . .	21	8
26NA40830 . . . . .	9	4
26NA40830 . . . . .	21	4
26NA40890 . . . . .	3	15
26NA40890 . . . . .	15	19
26NA47023 . . . . .	11	4
26NA47040 . . . . .	11	2
26NA47060 . . . . .	11	18
26NA47240 . . . . .	11	21
26NA47240 . . . . .	15	4
26NA47250 . . . . .	11	22

PART NUMBER	PAGE NO.	REF. NO.
26NA47250 . . . . .	15	6
26NA47260 . . . . .	11	20
26NA47260 . . . . .	15	3
26NA47280 . . . . .	11	24
26NA47280 . . . . .	15	7
26NA47291 . . . . .	11	16
26NA47300 . . . . .	11	17
26NA47350 . . . . .	3	1
26NA47380 . . . . .	11	27
26NA47390 . . . . .	9	27
26NA47390 . . . . .	11	14
26NA47390 . . . . .	21	26
26NA50080 . . . . .	5	11
26NA50080 . . . . .	17	11
26NA50091 . . . . .	5	10
26NA50091 . . . . .	17	17
26NA50630 . . . . .	5	14
26NA50630 . . . . .	17	14
26NA50640 . . . . .	5	15
26NA50640 . . . . .	17	15
26NA53931 . . . . .	5	3
26NA53931 . . . . .	17	4
26NA80041 . . . . .	9	12
26NA82510 . . . . .	9	3
26NA82510 . . . . .	21	3
26NA90330 . . . . .	13	4
26NA90330 . . . . .	25	7

PART NUMBER	PAGE NO.	REF. NO.
26NA97300 . . . . .	11	19
26NE97290 . . . . .	11	25
26NE97290 . . . . .	11	25
40AA40150 . . . . .	7	13
40AA40150 . . . . .	19	13
40AA40181 . . . . .	7	22
40AA40181 . . . . .	19	22
40AA40450 . . . . .	7	24
40AA40450 . . . . .	19	24
40AA47130 . . . . .	11	6
40AA76040 . . . . .	7	14
40AA76040 . . . . .	19	14
40AA77290 . . . . .	11	7
466078010 . . . . .	5	16
466078010 . . . . .	17	16
540047200 . . . . .	23	3
540076010 . . . . .	7	7
540076010 . . . . .	19	7
552085510 . . . . .	3	5
552085510 . . . . .	7	5
552085510 . . . . .	15	10
552085510 . . . . .	19	5
55TE97110 . . . . .	15	25
564047230 . . . . .	23	14

**Konica**

**PARTS CATALOG**

Model  
**DB-210/DB-410**

MARCH 2001

**KONICA BUSINESS TECHNOLOGIES, INC.**



This parts catalog includes illustrations and part numbers for all replacement parts and assemblies used in this model.

**Model-specific parts** are identified in the illustrations with reference numbers. Use the reference number to locate the corresponding part number on the facing page.

**Common hardware items**, such as screws, nuts, washers, and pins, are identified in the illustrations with reference letters. Use the reference letter to locate the corresponding part number on the hardware listing in the lower right hand corner of the facing page.

**If you know a part number**, but don't know where the part is used, use the numerical index to determine the page number and reference number for that part. Because some common parts are used in several places, there may be more than one entry. Refer to the illustrations to see where the part may be used.

**If you know a part's description**, but don't know where to look to find the part number, use the alphabetical index to determine likely page and reference numbers. Then look at the illustrations to determine that you have identified the correct part. Locate the part number using the listing on the opposite page.

**Retail pricing** that appears with the numerical index, while valid when this catalog was printed, is subject to change without notice. The prices are only suggested prices and are provided only for reference. Dealers may determine their own selling prices. For up-to-date pricing, refer to current Konica price lists or contact the Konica Parts Distribution Center.

### How to order parts

Use standard Konica parts ordering procedures to obtain these parts. For ordering options, contact Konica's Parts Distribution Center.

When ordering parts, be sure to specify part numbers exactly as listed in this catalog.

NOTE: Electrical parts may include previously used components.

This page left blank intentionally.



How to use this catalog . . . . . iii  
Contents . . . . . 1

DB-210 . . . . . 2

Wiring . . . . . 12

DB-410 . . . . . 14

Wiring . . . . . 24

Alphabetical index . . . . . 27  
Numerical index, Retail price list . . . . . 29

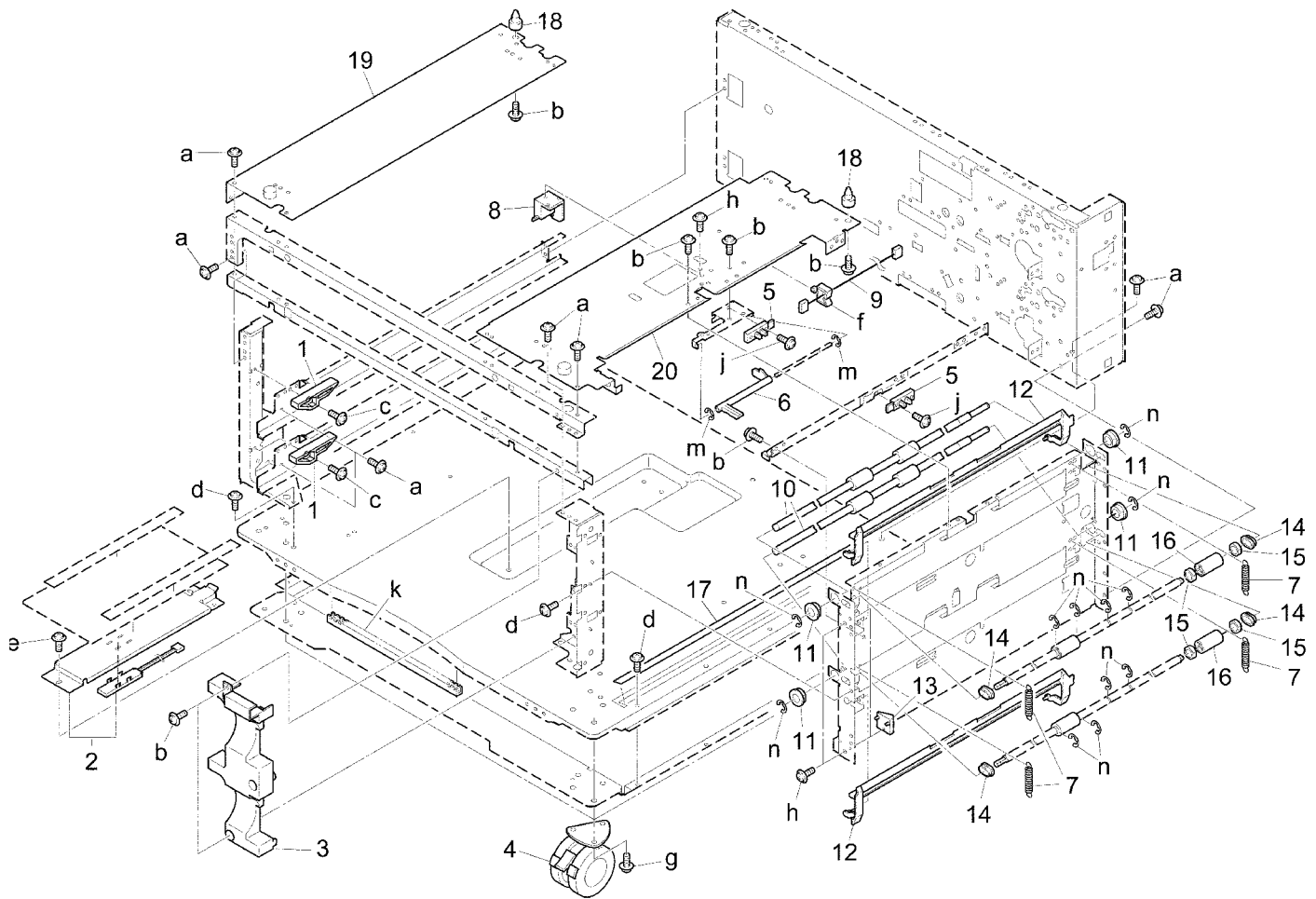

REF. NO.	PART NUMBER	DESCRIPTION
1	26NA47350	Cassette stopper
2	13HA-1122	Inner heater assembly
3	13GU12050	Cassette detecting cover
4	12XQ10040	Main support roller/A
5	552085510	Photosensor
6	13HA40060	Actuator/Upper
7	13HA40070	Driven spring
8	13GU40110	Shaft holder part
9	13HA90030	LCT wiring/2
10	13HA40021	Paper feed connecting roller/3
11	26NA40820	Paper feed slide shaft holder
12	26NA40270	Side guide plate
13	13HA10420	Lock part
14	13HA40150	Paper feed driven shaft holder
15	26NA40890	Slide shaft holder
16	26NA40680	Paper feed driven roller/Lower
17	13HA10530	Guide sheet/2
18	13HA10370	Main positioning shaft
19	13HA-1090	Main support plate left assembly
20	13HA-1070	Main support plate right assembly

HARDWARE	
REF. LTR.	PART NUMBER
a	00Z283061
b	00Z193061
c	00Z183061
d	00Z283081
e	00Z193041
f	00Z921941
g	00Z194101
h	00Z253081
j	00Z183121
k	00Z924316
m	00Z670206
n	00Z670606

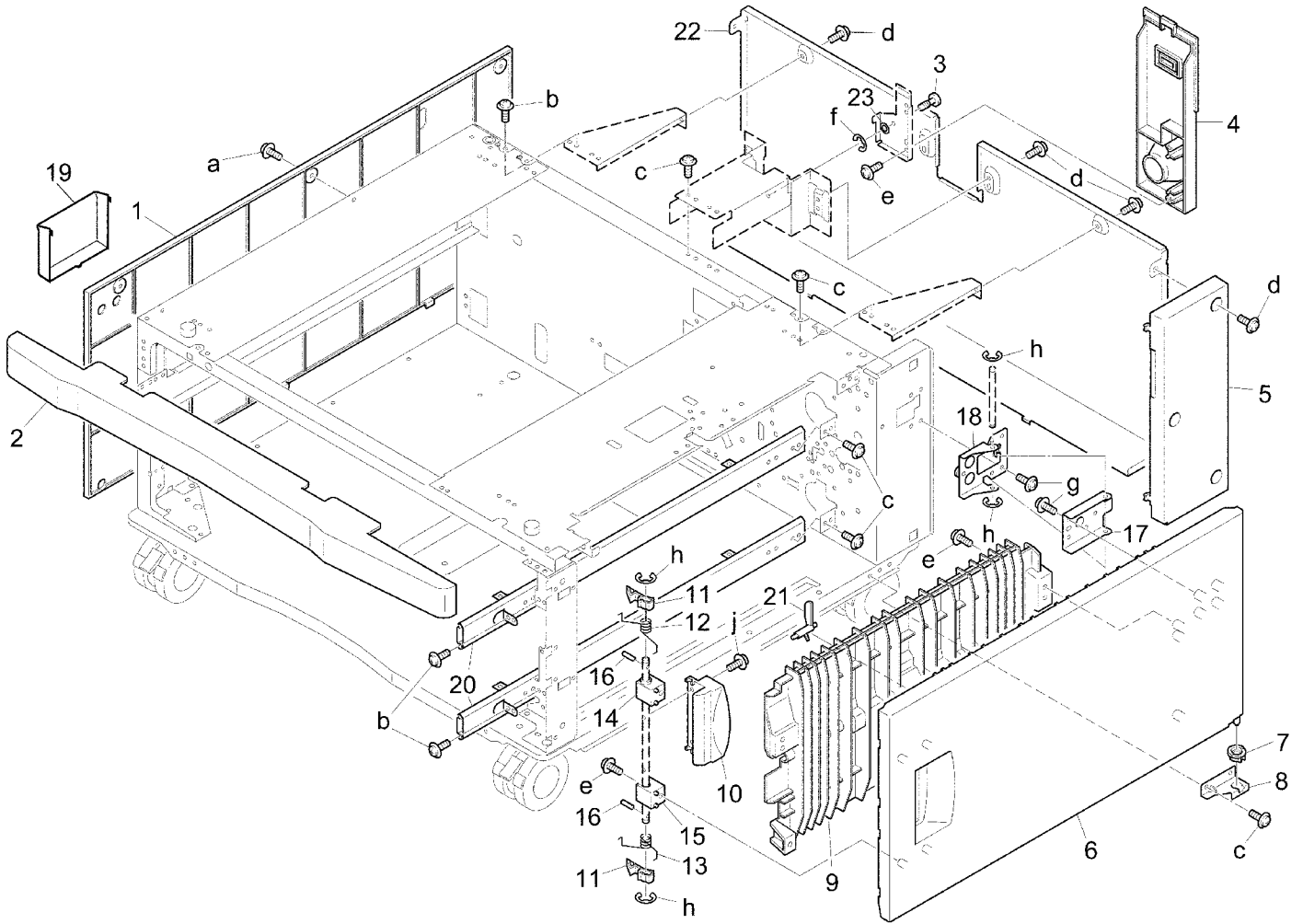

REF. NO.	PART NUMBER	DESCRIPTION
1	13HA12060	Side cover/Left
2	13GU12040	Front fixed cover
3	26NA53931	Fixed screw
4	13HA12150	Cord cover
5	13HA12080	Side cover/Right
6	13HA12020	Door/Right
7	13HA10470	Door fulcrum part
8	13HA10460	Door fulcrum plate
9	13HA40080	Guide plate/Middle
10	26NA50091	Open-close knob
11	26NA50080	Lock claw
12	13HA12160	Lock spring/Upper
13	13HA12170	Lock spring/Lower
14	26NA50630	Shaft holder part/Upper
15	26NA50640	Shaft holder part/Lower
16	466078010	Pin A
17	13HA10340	Hinge plate/A
18	13HA-1260	Guide plate/B assembly
19	26NA12540	Accessories holding panel
20	26NA10061	Cassette rail/Right
21	13HA10170	Actuator/Lower
22	13HA12070	Rear cover
23	13HA10550	Spacer/A

HARDWARE	
REF. LTR.	PART NUMBER
a	00Z283081
b	00Z193061
c	00Z283061
d	00Z193062
e	00Z253081
f	00Z670256
g	00Z254081
h	00Z670306
j	00Z193081

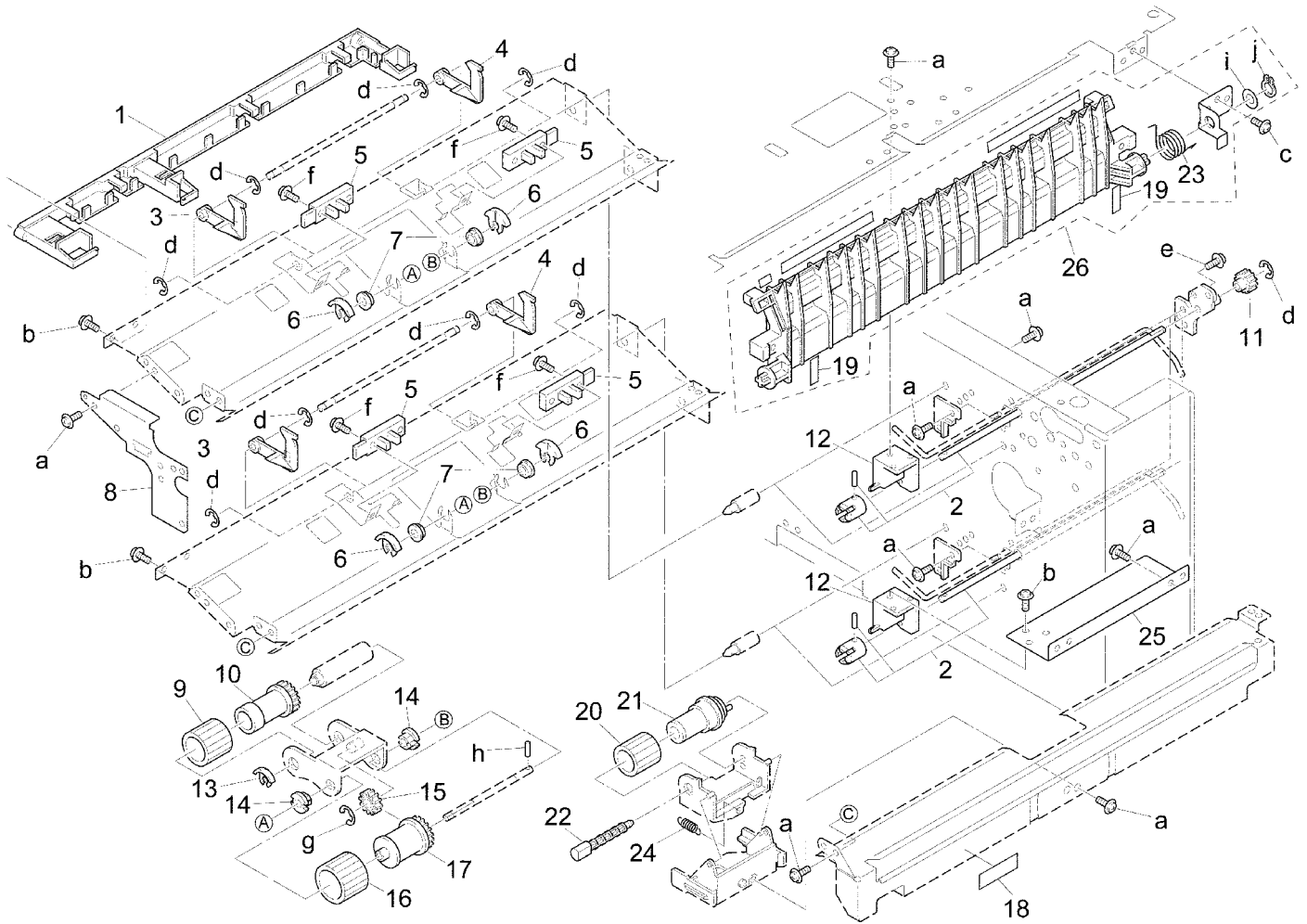

REF. NO.	PART NUMBER	DESCRIPTION
1	13HA40040	Wiring guide part
2	13HA-4040	Paper feed shaft/Rear assembly
3	26NA40280	Paper detecting actuator
4	26NA40750	Paper detecting actuator/2
5	552085510	Photosensor
6	26NA40700	Shaft positioning part
7	540076010	Paper feed shaft holder
8	13HA40030	Paper feed mount plate
9	26NA40090	Paper feeding rubber
10	26NA40080	Feeding roller
11	26NA16310	Paper feed gear (Z=15)
12	13GU40110	Shaft holder part
13	40AA40150	Shaft positioning part
14	40AA76040	Feeding shaft holder
15	26NA40510	Paper feed idler gear (Z=17)
16	26NA40110	Double feed preventive rubber/Upper
17	26NA40100	Double feed preventive roller/Upper
18	13HA40180	Holder part
19	13HA10560	Guide sheet/3
20	26NA40120	Double feed preventive rubber/Lower
21	26NA40500	Double feed preventive roller
22	40AA40181	Lever click shaft
23	13HA10450	Paper feed rotary spring
24	40AA40450	Double feed pressure spring
25	13GU40100	Shaft holder mount plate
26	13HA-1130	Guide plate/Middle assembly

HARDWARE	
REF. LTR.	PART NUMBER
a	00Z193061
b	00Z253081
c	00Z194061
d	00Z670306
e	00Z193051
f	00Z183121
g	00Z670406
h	00Z712106
i	00Z610501
j	00Z600506



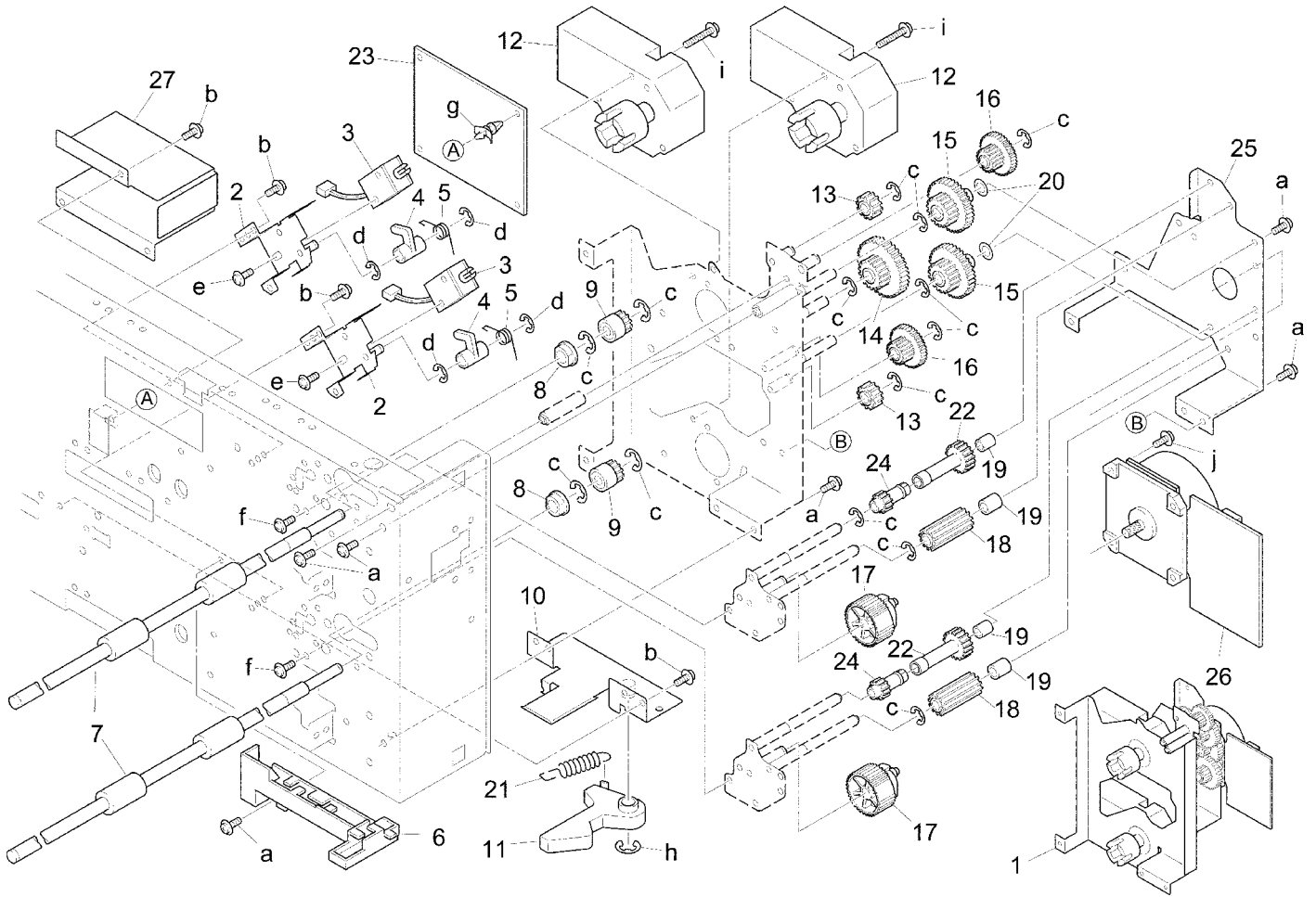

REF. NO.	PART NUMBER	DESCRIPTION
1	13NA-1500	Drive unit
2	13HA-1540	Solenoid mount plate assembly
3	26NA82510	Paper feed solenoid
4	26NA40830	Positioning arm
5	26NA40760	Lever hold spring
6	13HA10431	Wiring guide part/B
7	13HA40021	Paper feed connecting roller/3
8	26NA40820	Paper feed slide shaft holder
9	13HA77060	Driving gear (Z=15)
10	26NA-4780	Cassette lock assembly
11	25BA47461	Cassette positioning catch/U
12	26NA80041	Cassette driving motor
13	13HA77050	Idler gear/D (Z=17)
14	13NE77020	Idler gear/A (Z=29/69)
15	13NE77030	Idler gear/B (Z=23/35)
16	13HA77040	Idler gear/C (Z=16/31)
17	26NA-1680	Paper gear/2 assembly
18	13HA77080	Idler gear/F (Z=16)
19	13HA15110	Spacer
20	40AA32320	Toner supply spacer
21	26NA47390	Cassette fixed spring
22	13HA77090	Paper feed coupling gear/A
23	13NA-9010	PFU driving board assembly
24	26NA17490	Paper feed coupling gear/B
25	13NE15020	Driving panel/2
26	26TA80010	Drum driving motor
27	13HA10250	LCT cover

HARDWARE	
REF. LTR.	PART NUMBER
a	00Z193061
b	00Z283061
c	00Z670406
d	00Z670306
e	00Z163051
f	00Z183043
g	00Z925106
h	00Z670606
i	00Z193201
j	00Z184081

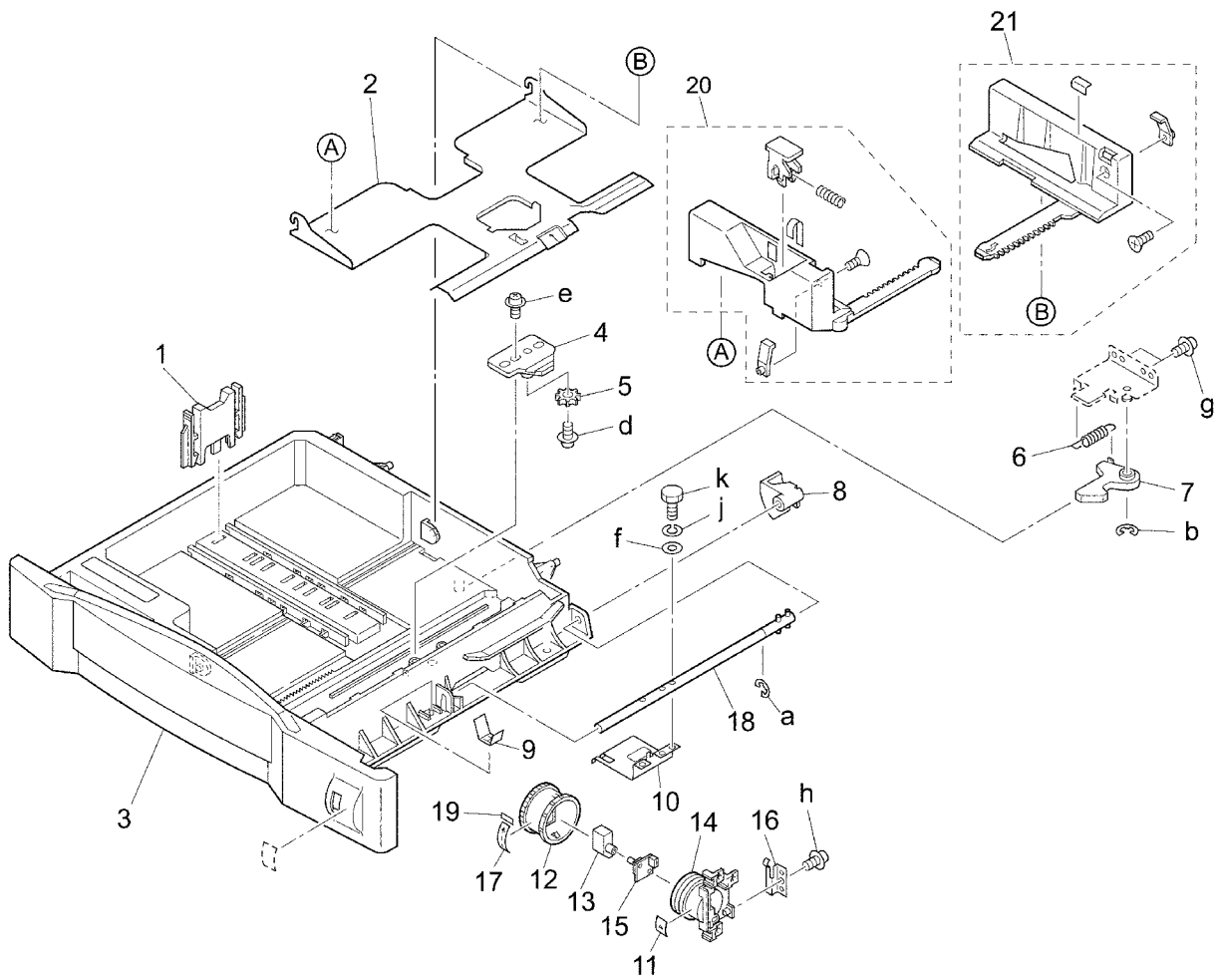

REF. NO.	PART NUMBER	DESCRIPTION
1	26NA47040	Paper feed regulating plate/Left
2	26NA-4740	Lift-up bottom plate assembly
3	26NA47023	Cassette base/Lower
4	40AA47130	Adjusting plate
5	40AA77290	Pinion (Z=16)
6	26NA47390	Cassette fixed spring
7	25BA47461	Cassette positioning catch/U
8	26NA47291	Cassette remained detecting actuator
9	26NA47300	Ground plate
10	26NA47060	Paper lift-up plate
11	26NA97300	Cassette click label
12	26NA47260	Paper feed indicating plate/Front
13	26NA47240	Cassette detecting connector
14	26NA47250	Cassette detecting base
15	26NA-9200	Size detecting board assembly
16	26NA47280	Spring lock plate
17	26NE97290	Cassette indication label/Lower
18	26NA-4760	Lift-up shaft assembly
19	26NA47381	Fixing seal
20	26NA-4721	Side regulating plate/Front assembly
21	26NA-4730	Side regulating plate/Rear assembly

  

HARDWARE	
REF. LTR.	PART NUMBER
a	00Z670406
b	00Z670606
d	00Z254081
e	00Z254121
f	00Z610301
g	00Z283061
h	00Z253081
j	00Z463103
k	00Z620301

# Wiring

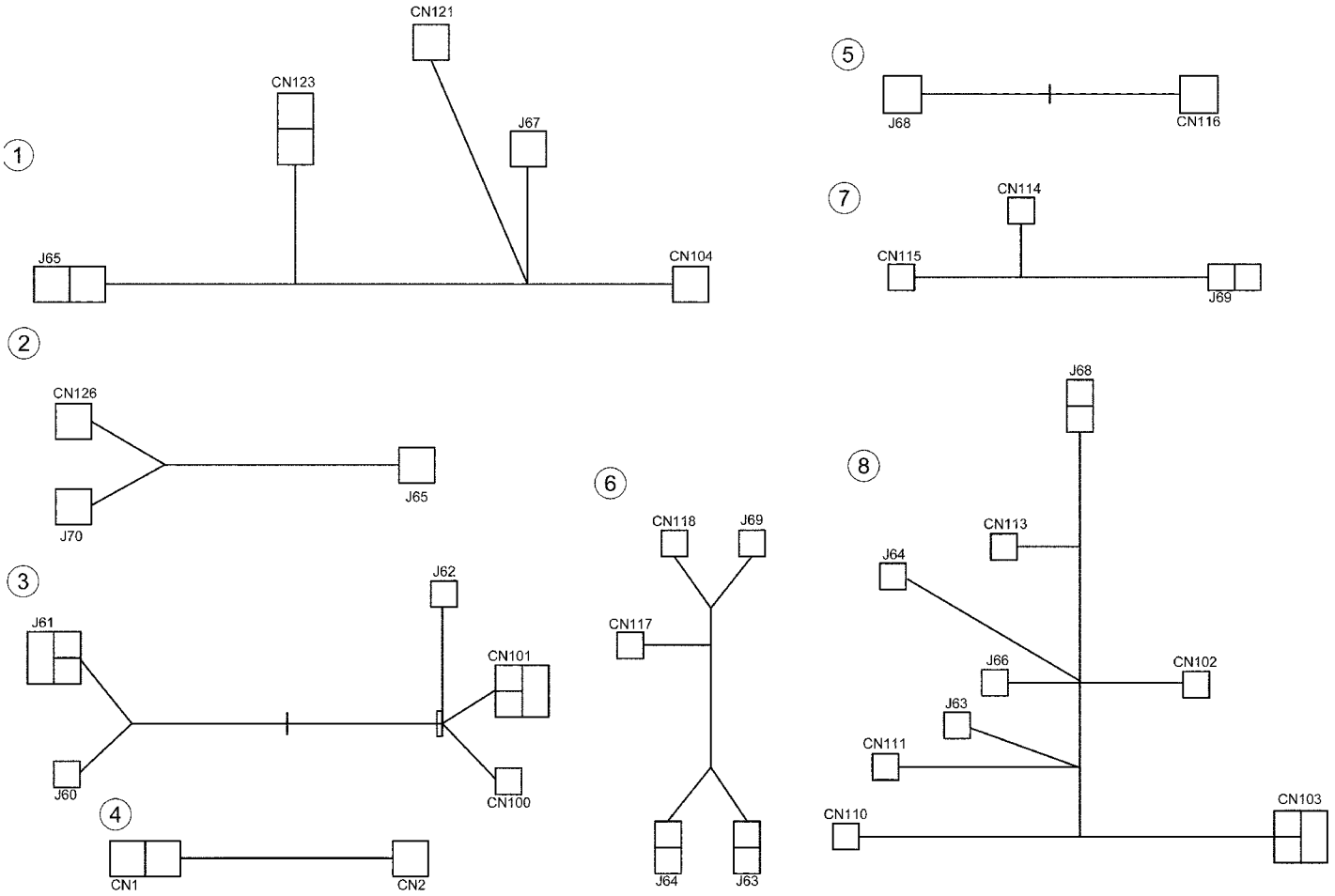

REF. NO.	PART NUMBER	DESCRIPTION
1	13GU90010	PFU wiring/1
2	13GU90020	PFU wiring/2
3	13HA90010	LCT electrify wiring
4	26NA90330	Relay wiring/3
5	13HA90030	LCT wiring/2
6	13HA90040	LCT wiring/3
7	13HA90060	LCT wiring/5
8	13NE90020	LCT wiring/1

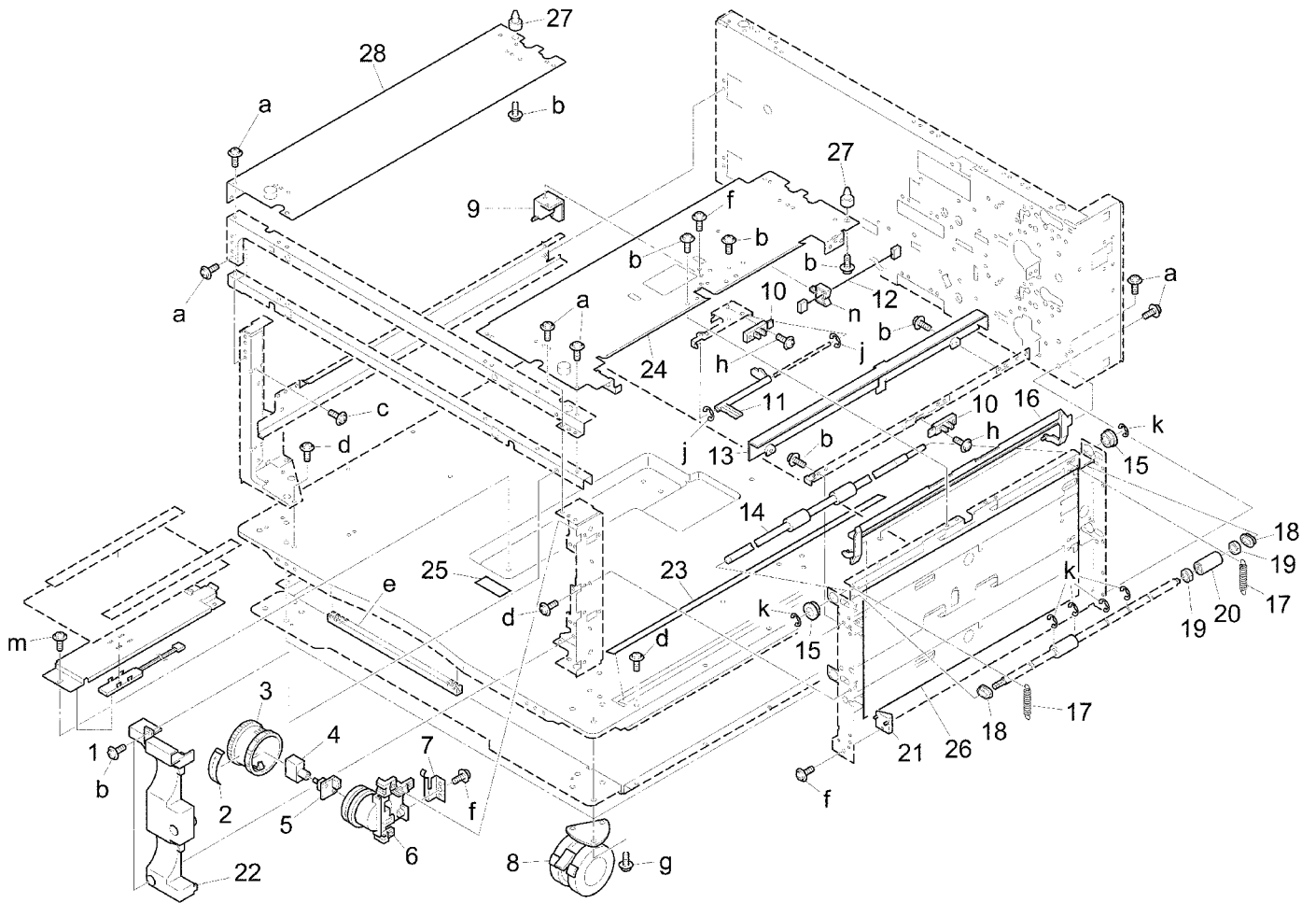

REF. NO.	PART NUMBER	DESCRIPTION
1	13HA-1122	Inner heater assembly
2	13HA-9720	Cassette label assembly
3	26NA47260	Paper feed indicating plate/Front
4	26NA47240	Cassette detecting connector
5	26NA-9200	Size detecting board assembly
6	26NA47250	Cassette detecting base
7	26NA47280	Spring lock plate
8	12XQ10040	Main support roller/A
9	13GU40110	Shaft holder part
10	552085510	Photosensor
11	13HA40060	Actuator/Upper
12	13HA90030	LCT wiring/2
13	13HA10390	Cover
14	13HA40021	Paper feed connecting roller/3
15	26NA40820	Paper feed slide shaft holder
16	26NA40270	Side guide plate
17	13HA40070	Roller spring
18	13HA40150	Paper feed driven shaft holder
19	26NA40890	Slide shaft holder
20	26NA40680	Paper feed driven roller
21	13HA10420	Lock part/2
22	13HA12180	Cassette detecting cover
23	13HA10530	Guide sheet/2
24	13HA-1070	Main support plate right assembly
25	55TE97110	High temperature caution label
26	13HA10540	Protection sheet
27	13HA10370	Main positioning shaft
28	13HA-1090	Main support plate left assembly

HARDWARE	
REF. LTR.	PART NUMBER
a	00Z283061
b	00Z193061
c	00Z183061
d	00Z283081
e	00Z924316
f	00Z253081
g	00Z194101
h	00Z183121
j	00Z670206
k	00Z670606
m	00Z193041
n	00Z921941



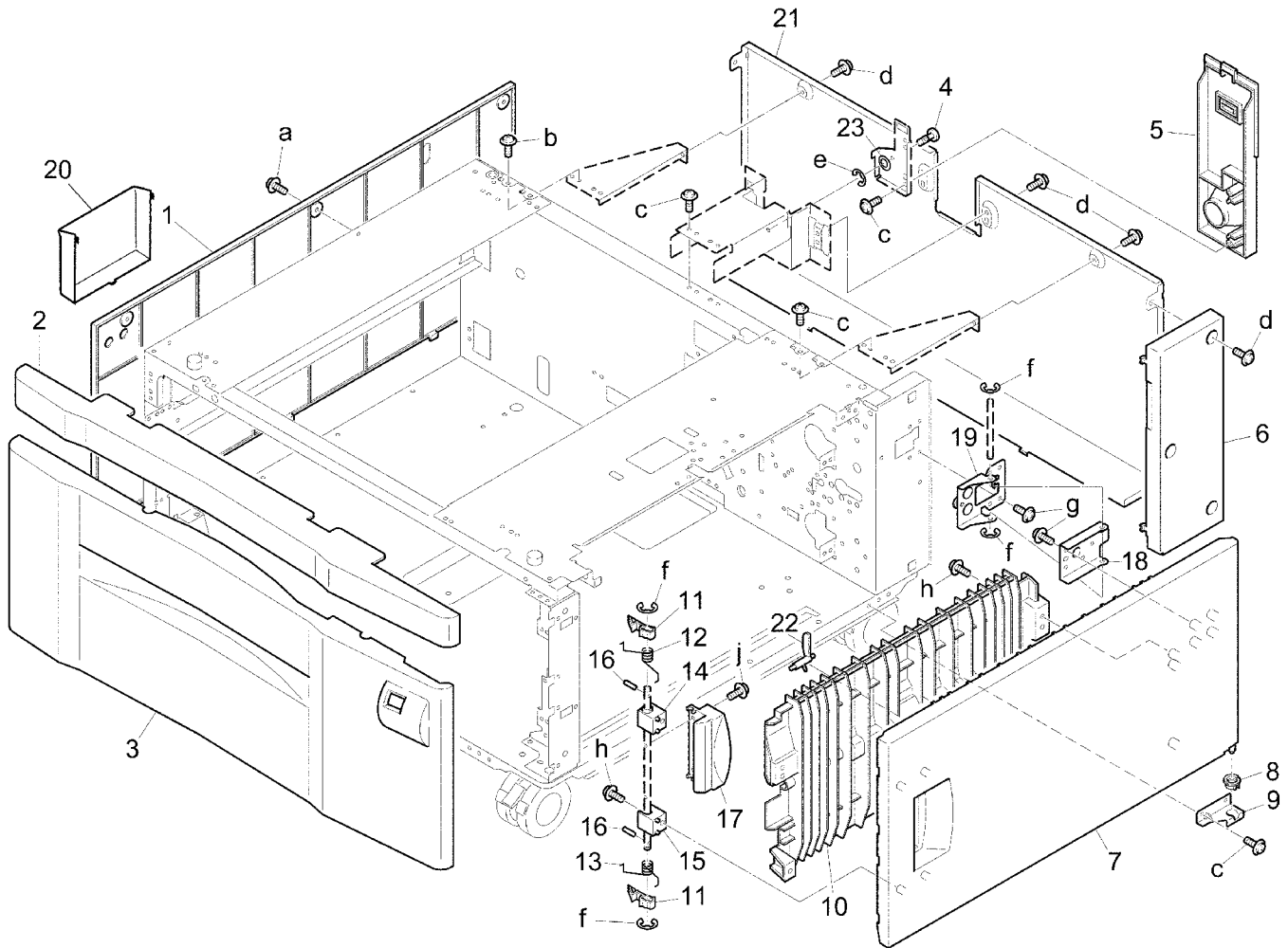

REF. NO.	PART NUMBER	DESCRIPTION
1	13HA12060	Fixed cover/Left
2	13HA12190	Front fixed cover
3	13HA12010	Front cover
4	26NA53931	Fixed screw
5	13HA12150	Cord cover
6	13HA12080	Side cover/Right
7	13HA12020	Door/Right
8	13HA10470	Door fulcrum part
9	13HA10460	Door fulcrum plate
10	13HA40080	Guide plate/Middle
11	26NA50080	Lock claw
12	13HA12160	Lock spring/Upper
13	13HA12170	Lock spring/Lower
14	26NA50630	Shaft holder part/Upper
15	26NA50640	Shaft holder part/Lower
16	466078010	Pin A
17	26NA50091	Open-close knob
18	13HA10340	Hinge plate/A
19	13HA-1260	Guide plate/B assembly
20	26NA12540	Accessories holding panel
21	13HA12070	Rear cover
22	13HA10170	Actuator/Lower
23	13HA10550	Spacer/A

HARDWARE	
REF. LTR.	PART NUMBER
a	00Z283081
b	00Z193061
c	00Z283061
d	00Z193062
e	00Z670256
f	00Z670306
g	00Z254081
h	00Z253081
j	00Z163101

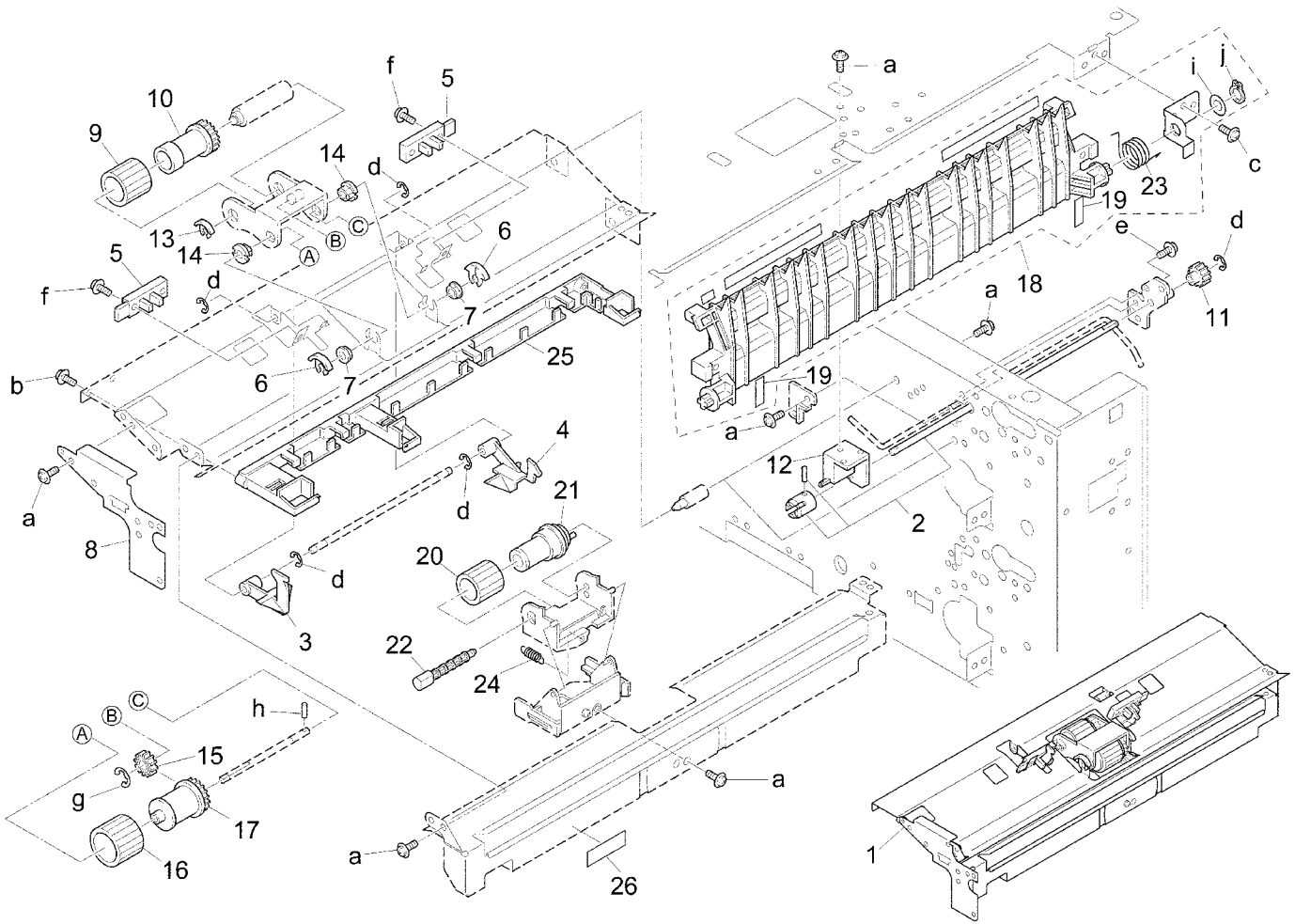

REF. NO.	PART NUMBER	DESCRIPTION
1	13HA-4000	Paper feed assembly
2	13HA-4040	Paper feed driving shaft/Rear assembly
3	13HA40171	Paper detecting actuator/Front
4	13HA40160	Paper detecting actuator/Rear
5	552085510	Photosensor
6	26NA40700	Shaft positioning part
7	540076010	Paper feed shaft holder
8	13HA40030	Paper feed mount plate
9	26NA40090	Paper feeding rubber
10	26NA40080	Feeding roller
11	26NA16310	Paper feed gear (Z=15)
12	13GU40110	Shaft holder part
13	40AA40150	Shaft positioning part
14	40AA76040	Feeding shaft holder
15	26NA40510	Paper feed idler gear (Z=17)
16	26NA40110	Double feed preventive rubber/Upper
17	26NA40100	Double feed preventive roller/Upper
18	13HA-1130	Guide plate/Middle assembly/Upper
19	13HA10560	Guide sheet/3
20	26NA40120	Double feed preventive roller/Lower
21	26NA40500	Double feed preventive roller
22	40AA40181	Lever click shaft
23	13HA10450	Paper feed rotary spring
24	40AA40450	Double feed pressure spring
25	13HA40040	Wiring guide part
26	13HA40180	Holder part

HARDWARE	
REF. LTR.	PART NUMBER
a	00Z193061
b	00Z253081
c	00Z194061
d	00Z670306
e	00Z193051
f	00Z183121
g	00Z670406
h	00Z712106
i	00Z610501
j	00Z600506

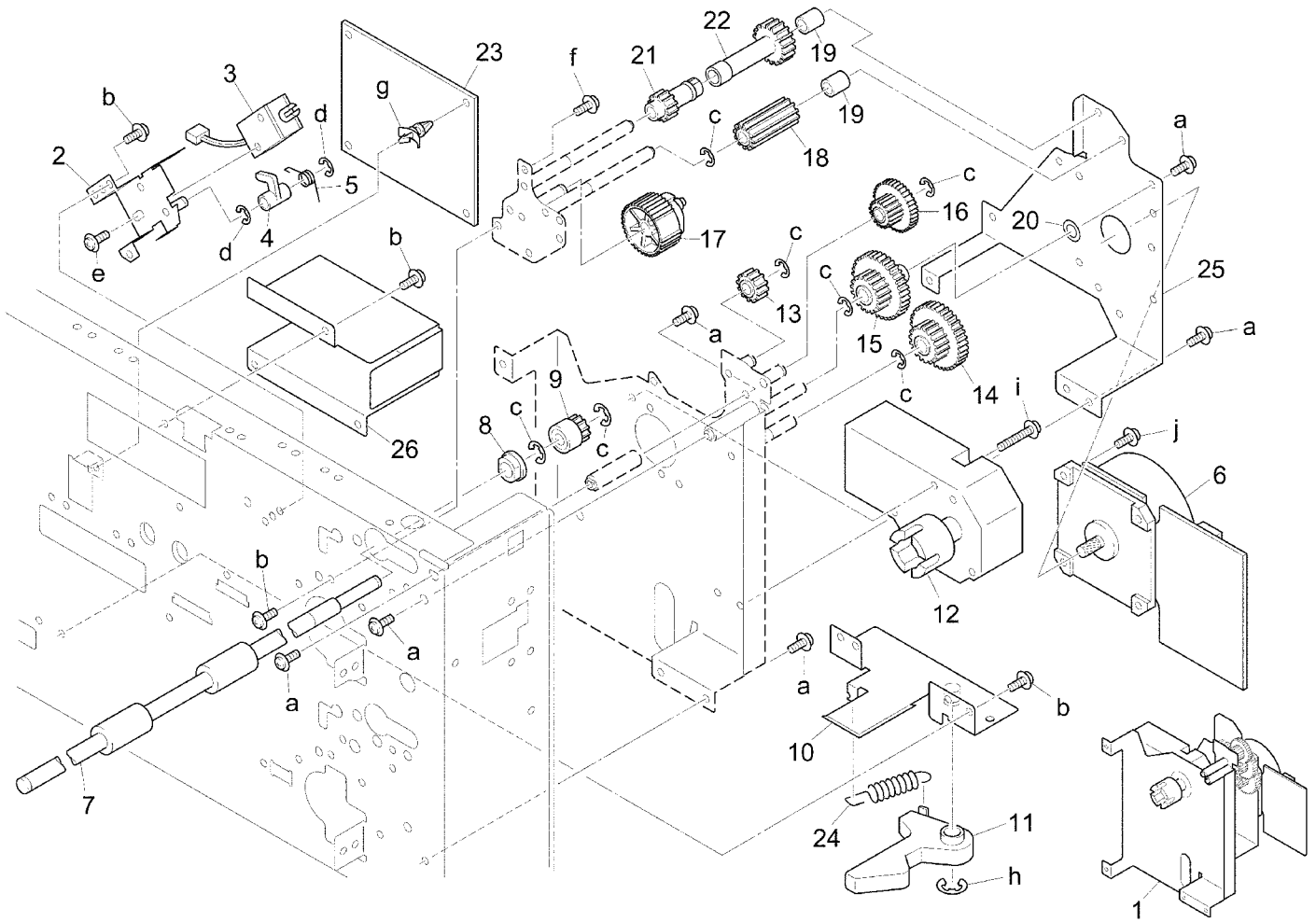

REF. NO.	PART NUMBER	DESCRIPTION
1	13NE-1500	Drive unit
2	13HA-1540	Solenoid mount plate assembly
3	26NA82510	Paper feed solenoid
4	26NA40830	Positioning arm
5	26NA40760	Lever hold spring
6	26TA80010	Drum driving motor
7	13HA40021	Paper feed connecting roller/3
8	26NA40820	Paper feed slide shaft holder
9	13HA77060	Driving gear (Z=15)
10	13HA-4780	LCT lock plate assembly
11	25BA47461	Cassette positioning cam/U
12	13HA80020	LCT driving motor
13	13HA77050	Idler gear/D (Z=17)
14	13NE77020	Idler gear/A (Z=29/69)
15	13NE77030	Idler gear/B (Z=23/35)
16	13HA77040	Idler gear/C (Z=16/31)
17	26NA-1680	Paper gear/2 assembly
18	13HA77080	Idler gear/F (Z=16)
19	13HA15110	Spacer
20	40AA32320	Toner supply spacer
21	26NA17490	Paper feed coupling gear/B
22	13HA77090	Paper feed coupling gear/A
23	13NE-9010	LCT driving board assembly
24	26NA47390	Cassette fixed spring
25	13NE15020	Driving panel/2
26	13HA10250	LCT cover

HARDWARE	
REF. LTR.	PART NUMBER
a	00Z193061
b	00Z283061
c	00Z670406
d	00Z670306
e	00Z163051
f	00Z183043
g	00Z925106
h	00Z670606
i	00Z193301
j	00Z184081

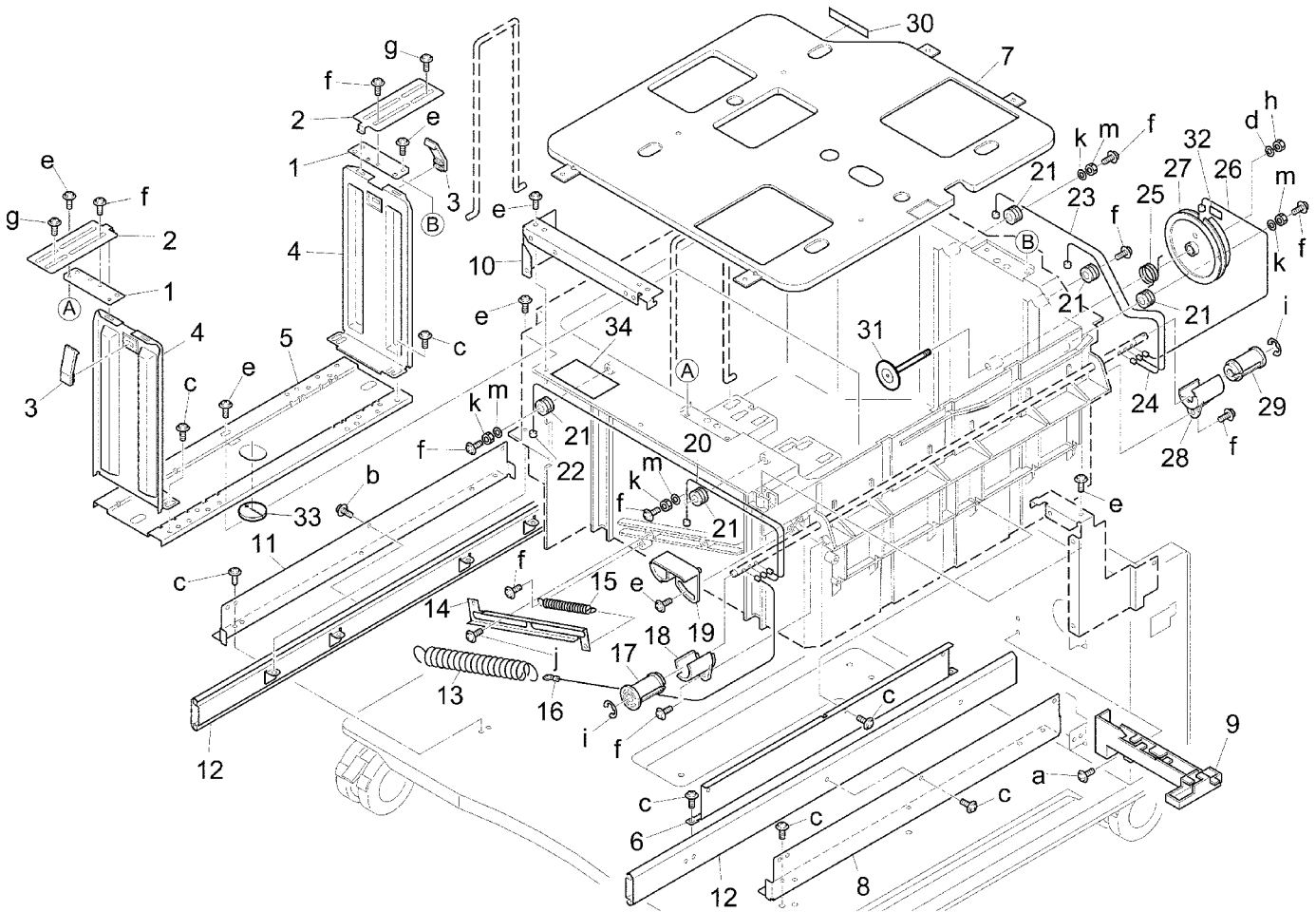

REF. NO.	PART NUMBER	DESCRIPTION
1	13HA47270	Fixed plate
2	13HA47250	Reinforcing plate
3	540047200	Paper regulating claw
4	13HA47280	Paper guide plate
5	12RQ47030	Paper adjusting plate
6	13HA47170	Main mount plate/Right
7	12RQ47020	Paper guide plate
8	13HA10130	Rail mount plate/Right
9	13HA10431	Wiring guide part/B
10	13HA12130	External mount plate/3
11	13HA10140	Rail mount plate/Left
12	13HA10161	LCT slide rail
13	13HA47140	Driving auxiliary spring/A
14	26NA47410	Spring mount plate
15	13HA47150	Driving auxiliary spring/B
16	12RQ47160	Auxiliary wire
17	12RQ47090	Wire driving pulley/Front
18	12RQ47110	Pulley fixed part/Front
19	12RQ47230	Wire adjusting part
20	13HA47100	Lift-up wire/1
21	13HA47210	Wire pulley
22	13HA47110	Lift-up wire/2
23	13HA47220	Lift-up wire/4
24	13HA47120	Lift-up wire/3
25	13HA47191	Detecting spring
26	13HA47130	Detecting wire
27	13HA47090	Detecting plate
28	13HA47260	Pulley fixed part/Rear
29	13HA47370	Driving pulley
30	13HA47330	Slide sheet
31	13HA-4790	Fulcrum shaft assembly
32	13HA47340	Stopper/A
33	13HA47380	Adjusting cam
34	13HA97050	LCT guide label

HARDWARE	
REF. LTR.	PART NUMBER
a	00Z193061
b	00Z193051
c	00Z283061
d	00Z510401
e	00Z254081
f	00Z183201
g	00Z163081
h	00Z610421
i	00Z670406
j	00Z193041
k	00Z610321
m	00Z510301

# Wiring



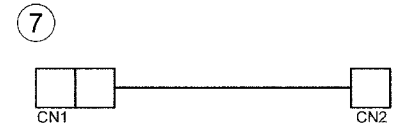
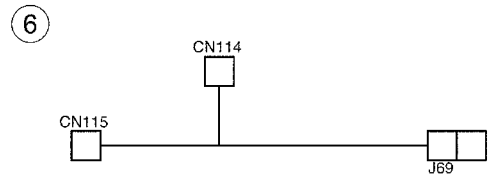
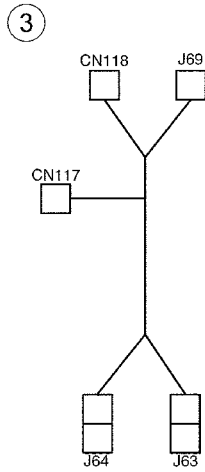
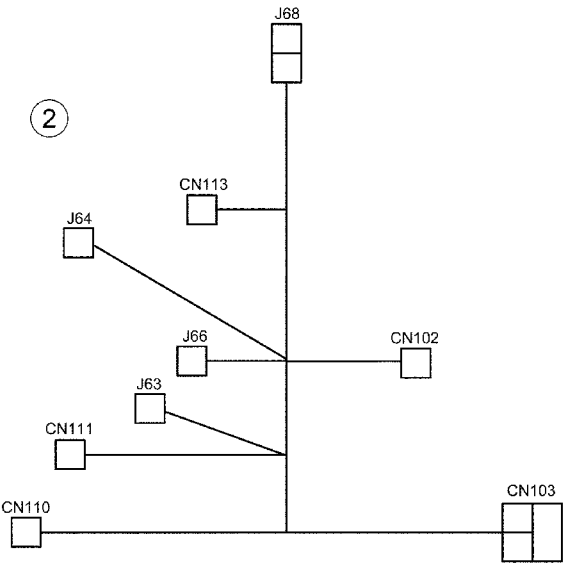
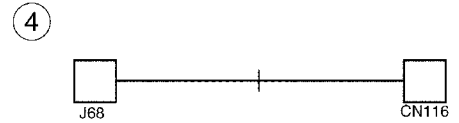
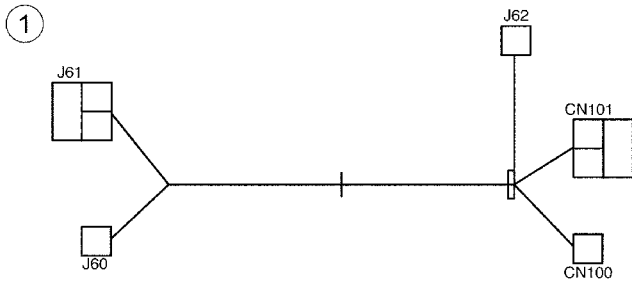

REF. NO.	PART NUMBER	DESCRIPTION
1	13HA90010	LCT electrify wiring
2	13NE90020	LCT wiring/1
3	13HA90040	LCT wiring/3
4	13HA90030	LCT wiring/2
5	13HA90050	LCT wiring/4
6	13HA90060	LCT wiring/5
7	26NA90330	Relay wiring/3

This page left blank intentionally.

## Alphabetical index

PART DESCRIPTION	PAGE NO.	REF. NO.	PART DESCRIPTION	PAGE NO.	REF. NO.	PART DESCRIPTION	PAGE NO.	REF. NO.
<b>A</b>			Double feed preventive rubber/Upper . . . . .	7	16	Holder part . . . . .	19	26
Accessories holding panel . . . . .	5	19	Double feed preventive rubber/Lower . . . . .	7	20	<b>I</b>		
Accessories holding panel . . . . .	17	20	Double feed preventive rubber/Upper . . . . .	19	16	Idler gear/A (Z=29/69) . . . . .	9	14
Actuator/Lower . . . . .	5	21	Drive unit . . . . .	9	1	Idler gear/A (Z=29/69) . . . . .	21	14
Actuator/Lower . . . . .	17	22	Drive unit . . . . .	21	1	Idler gear/B (Z=23/35) . . . . .	9	15
Actuator/Upper . . . . .	3	6	Driven spring . . . . .	3	7	Idler gear/B (Z=23/35) . . . . .	21	15
Actuator/Upper . . . . .	15	11	Driving auxiliary spring/A . . . . .	23	13	Idler gear/C (Z=16/31) . . . . .	9	16
Adjusting cam . . . . .	23	33	Driving auxiliary spring/B . . . . .	23	15	Idler gear/C (Z=16/31) . . . . .	21	16
Adjusting plate . . . . .	11	4	Driving gear (Z=15) . . . . .	9	9	Idler gear/D (Z=17) . . . . .	9	13
Auxiliary wire . . . . .	23	16	Driving gear (Z=15) . . . . .	21	9	Idler gear/D (Z=17) . . . . .	21	13
<b>C</b>			Driving panel/2 . . . . .	9	25	Idler gear/F (Z=16) . . . . .	9	18
Cassette base/Lower . . . . .	11	3	Driving panel/2 . . . . .	21	25	Idler gear/F (Z=16) . . . . .	21	18
Cassette click label . . . . .	11	11	Driving pulley . . . . .	23	29	Inner heater assembly . . . . .	3	2
Cassette detecting base . . . . .	11	14	Drum driving motor . . . . .	9	26	Inner heater assembly . . . . .	15	1
Cassette detecting base . . . . .	15	6	Drum driving motor . . . . .	21	6	<b>L</b>		
Cassette detecting connector . . . . .	11	13	<b>E</b>			LCT cover . . . . .	9	27
Cassette detecting connector . . . . .	15	4	External mount plate/3 . . . . .	23	10	LCT cover . . . . .	21	26
Cassette detecting cover . . . . .	3	3	<b>F</b>			LCT driving board assembly . . . . .	21	23
Cassette detecting cover . . . . .	15	22	Feeding roller . . . . .	7	10	LCT driving motor . . . . .	21	12
Cassette driving motor . . . . .	9	12	Feeding roller . . . . .	19	10	LCT electrify wiring . . . . .	13	3
Cassette fixed spring . . . . .	9	21	Feeding shaft holder . . . . .	7	14	LCT electrify wiring . . . . .	25	1
Cassette fixed spring . . . . .	11	6	Feeding shaft holder . . . . .	19	14	LCT guide label . . . . .	23	34
Cassette fixed spring . . . . .	21	24	Fixed cover/Left . . . . .	17	1	LCT lock plate assembly . . . . .	21	10
Cassette indication label/Lower . . . . .	11	17	Fixed plate . . . . .	23	1	LCT slide rail . . . . .	23	12
Cassette label assembly . . . . .	15	2	Fixed screw . . . . .	5	3	LCT wiring/1 . . . . .	13	8
Cassette lock assembly . . . . .	9	10	Fixed screw . . . . .	17	4	LCT wiring/1 . . . . .	25	2
Cassette positioning cam/U . . . . .	21	11	Fixing seal . . . . .	11	19	LCT wiring/2 . . . . .	3	9
Cassette positioning catch/U . . . . .	9	11	Front cover . . . . .	17	3	LCT wiring/2 . . . . .	13	5
Cassette positioning catch/U . . . . .	11	7	Front fixed cover . . . . .	5	2	LCT wiring/2 . . . . .	15	12
Cassette rail/Right . . . . .	5	20	Front fixed cover . . . . .	17	2	LCT wiring/2 . . . . .	25	4
Cassette remained detecting actuator . . . . .	11	8	Fulcrum shaft assembly . . . . .	23	31	LCT wiring/3 . . . . .	13	6
Cassette stopper . . . . .	3	1	<b>G</b>			LCT wiring/3 . . . . .	25	3
Cord cover . . . . .	5	4	Ground plate . . . . .	11	9	LCT wiring/4 . . . . .	25	5
Cord cover . . . . .	17	5	Guide plate/B assembly . . . . .	5	18	LCT wiring/5 . . . . .	13	7
Cover . . . . .	15	13	Guide plate/B assembly . . . . .	17	19	LCT wiring/5 . . . . .	25	6
<b>D</b>			Guide plate/Middle . . . . .	5	9	Lever click shaft . . . . .	7	22
Detecting plate . . . . .	23	27	Guide plate/Middle . . . . .	17	10	Lever click shaft . . . . .	19	22
Detecting spring . . . . .	23	25	Guide plate/Middle assembly . . . . .	7	26	Lever hold spring . . . . .	9	5
Detecting wire . . . . .	23	26	Guide plate/Middle assembly . . . . .	19	18	Lever hold spring . . . . .	21	5
Door fulcrum part . . . . .	5	7	Guide sheet/2 . . . . .	3	17	Lift-up bottom plate assembly . . . . .	11	2
Door fulcrum part . . . . .	17	8	Guide sheet/2 . . . . .	15	23	Lift-up shaft assembly . . . . .	11	18
Door fulcrum plate . . . . .	5	8	Guide sheet/3 . . . . .	7	19	Lift-up wire/1 . . . . .	23	20
Door fulcrum plate . . . . .	17	9	Guide sheet/3 . . . . .	19	19	Lift-up wire/2 . . . . .	23	22
Door/Right . . . . .	5	6	<b>H</b>			Lift-up wire/3 . . . . .	23	24
Door/Right . . . . .	17	7	High temperature caution label . . . . .	15	25	Lift-up wire/4 . . . . .	23	23
Double feed pressure spring . . . . .	7	24	Hinge plate/A . . . . .	5	17	Lock claw . . . . .	5	11
Double feed pressure spring . . . . .	19	24	Hinge plate/A . . . . .	17	18	Lock claw . . . . .	17	11
Double feed preventive roller . . . . .	7	21	Holder part . . . . .	7	18	Lock part . . . . .	3	13
Double feed preventive roller . . . . .	19	21	<b>M</b>			Lock part/2 . . . . .	15	21
Double feed preventive roller/Upper . . . . .	7	17	Main mount plate/Right . . . . .	23	6	Lock spring/Lower . . . . .	5	13
Double feed preventive roller/Upper . . . . .	19	17				Lock spring/Lower . . . . .	17	13
Double feed preventive roller/Lower . . . . .	19	20				Lock spring/Upper . . . . .	5	12
						Lock spring/Upper . . . . .	17	12

PART DESCRIPTION	PAGE NO.	REF. NO.	PART DESCRIPTION	PAGE NO.	REF. NO.	PART DESCRIPTION	PAGE NO.	REF. NO.
Main positioning shaft . . . .	3	18	Paper feed indicating plate/Front . . . . .	11	12	Shaft holder part . . . . .	7	12
Main positioning shaft . . . .	15	27	Paper feed indicating plate/Front . . . . .	15	3	Shaft holder part . . . . .	15	9
Main support plate left assembly . . . . .	3	19	Paper feed mount plate . . . .	7	8	Shaft holder part . . . . .	19	12
Main support plate left assembly . . . . .	15	28	Paper feed mount plate . . . .	19	8	Shaft holder part/Lower . . .	5	15
Main support plate right assembly . . . . .	3	20	Paper feed regulating plate/Left . . . . .	11	1	Shaft holder part/Upper . . .	17	15
Main support plate right assembly . . . . .	15	24	Paper feed rotary spring . . .	7	23	Shaft holder part/Upper . . .	17	14
Main support roller/A . . . . .	3	4	Paper feed rotary spring . . .	19	23	Shaft positioning part . . . .	7	6
Main support roller/A . . . . .	15	8	Paper feed shaft holder . . . .	7	7	Shaft positioning part . . . .	7	13
			Paper feed shaft holder . . . .	19	7	Shaft positioning part . . . .	19	6
			Paper feed shaft/Rear assembly . . . . .	7	2	Side cover/Left . . . . .	5	1
<b>O</b>			Paper feed slide shaft holder	3	11	Side cover/Right . . . . .	5	5
Open-close knob . . . . .	5	10	Paper feed slide shaft holder	9	8	Side cover/Right . . . . .	17	6
Open-close knob . . . . .	17	17	Paper feed slide shaft holder	15	15	Side guide plate . . . . .	17	6
			Paper feed slide shaft holder	21	8	Side guide plate . . . . .	3	12
			Paper feed solenoid . . . . .	9	3	Side guide plate . . . . .	15	16
			Paper feed solenoid . . . . .	21	3	Side regulating plate/Front assembly . . . . .	11	20
			Paper feeding rubber . . . . .	7	9	Side regulating plate/Rear assembly . . . . .	11	21
			Paper feeding rubber . . . . .	19	9	Size detecting board assembly . . . . .	11	15
			Paper gear/2 assembly . . . .	9	17	Size detecting board assembly . . . . .	11	15
			Paper gear/2 assembly . . . .	21	17	Size detecting board assembly . . . . .	15	5
			Paper guide plate . . . . .	23	4	Slide shaft holder . . . . .	3	15
			Paper guide plate . . . . .	23	7	Slide shaft holder . . . . .	15	19
			Paper lift-up plate . . . . .	11	10	Slide sheet . . . . .	23	30
			Paper regulating claw . . . .	23	3	Solenoid mount plate assembly . . . . .	9	2
			Photosensor . . . . .	3	5	Solenoid mount plate assembly . . . . .	21	2
			Photosensor . . . . .	7	5	Spacer . . . . .	9	19
			Photosensor . . . . .	15	10	Spacer . . . . .	21	19
			Pin A . . . . .	19	5	Spacer/A . . . . .	5	23
			Pin A . . . . .	5	16	Spacer/A . . . . .	17	23
			Pin A . . . . .	17	16	Spring lock plate . . . . .	11	16
			Pinion (Z=16) . . . . .	11	5	Spring lock plate . . . . .	15	7
			Positioning arm . . . . .	9	4	Spring mount plate . . . . .	23	14
			Positioning arm . . . . .	21	4	Stopper/A . . . . .	23	32
			Protection sheet . . . . .	15	26			
			Pulley fixed part/Front . . . .	23	18			
			Pulley fixed part/Rear . . . .	23	28			
						<b>T</b>		
						Toner supply spacer . . . . .	9	20
						Toner supply spacer . . . . .	21	20
			<b>R</b>					
			Rail mount plate/Left . . . . .	23	11			
			Rail mount plate/Right . . . .	23	8			
			Rear cover . . . . .	5	22			
			Rear cover . . . . .	17	21	<b>W</b>		
			Reinforcing plate . . . . .	23	2	Wire adjusting part . . . . .	23	19
			Relay wiring/3 . . . . .	13	4	Wire driving pulley/Front . .	23	17
			Relay wiring/3 . . . . .	25	7	Wire pulley . . . . .	23	21
			Roller spring . . . . .	15	17	Wiring guide part . . . . .	7	1
						Wiring guide part . . . . .	19	25
						Wiring guide part/B . . . . .	9	6
						Wiring guide part/B . . . . .	23	9
			<b>S</b>					
			Shaft holder mount plate . . .	7	25			
			Shaft holder part . . . . .	3	8			

## Numerical index

PART NUMBER	PAGE NO.	REF. NO.	PART NUMBER	PAGE NO.	REF. NO.	PART NUMBER	PAGE NO.	REF. NO.
12RQ47020	23	7	13HA12010	17	3	13HA77060	21	9
12RQ47030	23	5	13HA12020	5	6	13HA77080	9	18
12RQ47090	23	17	13HA12020	17	7	13HA77080	21	18
12RQ47110	23	18	13HA12060	5	1	13HA77090	9	22
12RQ47160	23	16	13HA12060	17	1	13HA77090	21	22
12RQ47230	23	19	13HA12070	5	22	13HA80020	21	12
12XQ10040	3	4	13HA12070	17	21	13HA90010	13	3
12XQ10040	15	8	13HA12080	5	5	13HA90010	25	1
13GU12040	5	2	13HA12080	17	6	13HA90030	3	9
13GU12050	3	3	13HA12130	23	10	13HA90030	13	5
13GU40100	7	25	13HA12150	5	4	13HA90030	15	12
13GU40110	3	8	13HA12150	17	5	13HA90030	25	4
13GU40110	7	12	13HA12160	5	12	13HA90040	13	6
13GU40110	15	9	13HA12160	17	12	13HA90040	25	3
13GU40110	19	12	13HA12170	5	13	13HA90050	25	5
13GU90010	13	1	13HA12170	17	13	13HA90060	13	7
13GU90020	13	2	13HA12180	15	22	13HA90060	25	6
13HA-1070	3	20	13HA12190	17	2	13HA97050	23	34
13HA-1070	15	24	13HA15110	9	19	13NA-1500	9	1
13HA-1090	3	19	13HA15110	21	19	13NA-9010	9	23
13HA-1090	15	28	13HA40021	3	10	13NE-1500	21	1
13HA-1122	3	2	13HA40021	9	7	13NE-9010	21	23
13HA-1122	15	1	13HA40021	15	14	13NE15020	9	25
13HA-1130	7	26	13HA40021	21	7	13NE15020	21	25
13HA-1130	19	18	13HA40030	7	8	13NE77020	9	14
13HA-1260	5	18	13HA40030	19	8	13NE77020	21	14
13HA-1260	17	19	13HA40040	7	1	13NE77030	9	15
13HA-1540	9	2	13HA40040	19	25	13NE77030	21	15
13HA-1540	21	2	13HA40060	3	6	13NE90020	13	8
13HA-4000	19	1	13HA40060	15	11	13NE90020	25	2
13HA-4040	7	2	13HA40070	3	7	25BA47461	9	11
13HA-4040	19	2	13HA40070	15	17	25BA47461	11	7
13HA-4780	21	10	13HA40080	5	9	25BA47461	21	11
13HA-4790	23	31	13HA40080	17	10	26NA-1680	9	17
13HA-9720	15	2	13HA40150	3	14	26NA-1680	21	17
13HA10130	23	8	13HA40150	15	18	26NA-4721	11	20
13HA10140	23	11	13HA40160	19	4	26NA-4730	11	21
13HA10161	23	12	13HA40171	19	3	26NA-4740	11	2
13HA10170	5	21	13HA40180	7	18	26NA-4760	11	18
13HA10170	17	22	13HA40180	19	26	26NA-4780	9	10
13HA10250	9	27	13HA47090	23	27	26NA-9200	11	15
13HA10250	21	26	13HA47100	23	20	26NA-9200	15	5
13HA10340	5	17	13HA47110	23	22	26NA10061	5	20
13HA10340	17	18	13HA47120	23	24	26NA12540	5	19
13HA10370	3	18	13HA47130	23	26	26NA12540	17	20
13HA10370	15	27	13HA47140	23	13	26NA16310	7	11
13HA10390	15	13	13HA47150	23	15	26NA16310	19	11
13HA10420	3	13	13HA47170	23	6	26NA17490	9	24
13HA10420	15	21	13HA47191	23	25	26NA17490	21	21
13HA10431	9	6	13HA47210	23	21	26NA40080	7	10
13HA10431	23	9	13HA47220	23	23	26NA40080	19	10
13HA10450	7	23	13HA47250	23	2	26NA40090	7	9
13HA10450	19	23	13HA47260	23	28	26NA40090	19	9
13HA10460	5	8	13HA47270	23	1	26NA40100	7	17
13HA10460	17	9	13HA47280	23	4	26NA40100	19	17
13HA10470	5	7	13HA47330	23	30	26NA40110	7	16
13HA10470	17	8	13HA47340	23	32	26NA40110	19	16
13HA10530	3	17	13HA47370	23	29	26NA40120	7	20
13HA10530	15	23	13HA47380	23	33	26NA40120	19	20
13HA10540	15	26	13HA77040	9	16	26NA40270	3	12
13HA10550	5	23	13HA77040	21	16	26NA40270	15	16
13HA10550	17	23	13HA77050	9	13	26NA40280	7	3
13HA10560	7	19	13HA77050	21	13	26NA40500	7	21
13HA10560	19	19	13HA77060	9	9	26NA40500	19	21

PART NUMBER	PAGE NO.	REF. NO.
26NA40510 . . . . .	7	15
26NA40510 . . . . .	19	15
26NA40680 . . . . .	3	16
26NA40680 . . . . .	15	20
26NA40700 . . . . .	7	6
26NA40700 . . . . .	19	6
26NA40750 . . . . .	7	4
26NA40760 . . . . .	9	5
26NA40760 . . . . .	21	5
26NA40820 . . . . .	3	11
26NA40820 . . . . .	9	8
26NA40820 . . . . .	15	15
26NA40820 . . . . .	21	8
26NA40830 . . . . .	9	4
26NA40830 . . . . .	21	4
26NA40890 . . . . .	3	15
26NA40890 . . . . .	15	19
26NA47023 . . . . .	11	3
26NA47040 . . . . .	11	1
26NA47060 . . . . .	11	10
26NA47240 . . . . .	11	13
26NA47240 . . . . .	15	4
26NA47250 . . . . .	11	14
26NA47250 . . . . .	15	6
26NA47260 . . . . .	11	12
26NA47260 . . . . .	15	3

PART NUMBER	PAGE NO.	REF. NO.
26NA47280 . . . . .	11	16
26NA47280 . . . . .	15	7
26NA47291 . . . . .	11	8
26NA47300 . . . . .	11	9
26NA47350 . . . . .	3	1
26NA47381 . . . . .	11	19
26NA47390 . . . . .	9	21
26NA47390 . . . . .	11	6
26NA47390 . . . . .	21	24
26NA47410 . . . . .	23	14
26NA50080 . . . . .	5	11
26NA50080 . . . . .	17	11
26NA50091 . . . . .	5	10
26NA50091 . . . . .	17	17
26NA50630 . . . . .	5	14
26NA50630 . . . . .	17	14
26NA50640 . . . . .	5	15
26NA50640 . . . . .	17	15
26NA53931 . . . . .	5	3
26NA53931 . . . . .	17	4
26NA80041 . . . . .	9	12
26NA82510 . . . . .	9	3
26NA82510 . . . . .	21	3
26NA90330 . . . . .	13	4
26NA90330 . . . . .	25	7
26NA97300 . . . . .	11	11

PART NUMBER	PAGE NO.	REF. NO.
26NE97290 . . . . .	11	17
26TA80010 . . . . .	9	26
26TA80010 . . . . .	21	6
40AA32320 . . . . .	9	20
40AA32320 . . . . .	21	20
40AA40150 . . . . .	7	13
40AA40150 . . . . .	19	13
40AA40181 . . . . .	7	22
40AA40181 . . . . .	19	22
40AA40450 . . . . .	7	24
40AA40450 . . . . .	19	24
40AA47130 . . . . .	11	4
40AA76040 . . . . .	7	14
40AA76040 . . . . .	19	14
40AA77290 . . . . .	11	5
466078010 . . . . .	5	16
466078010 . . . . .	17	16
540047200 . . . . .	23	3
540076010 . . . . .	7	7
540076010 . . . . .	19	7
552085510 . . . . .	3	5
552085510 . . . . .	7	5
552085510 . . . . .	15	10
552085510 . . . . .	19	5
55TE97110 . . . . .	15	25