

Room Air Conditioning SERVICE Manual



Friedrich

Table of Contents

		<i>Page</i>	
Typical Unit Components	3	Refrigerant Charging	40-41
Introduction	3	Undercharged Refrigerant Systems	41-42
Unit Identification	4	Overcharged Refrigerant Systems	42
Unit Specifications	5	Restricted Refrigerant System	43
Unit Performance	7-20	Routine Maintenance	44
Refrigeration Sequence of Operation	21	Troubleshooting	45-55
Electrical Rating Tables	22	Wiring Diagrams	
Compressor	23	"RS", "RM",	618-200-17 56
Thermal Overload (External)	23	"SQ"	617-581-09 57
Thermal Overload (Internal)	24	"KQ"	617-581-04 58
Fan Motor	24	"YQ"	617-581-05 59
System Switches/Controls	25-33	"SC"	614-406-00 60
Thermostats (Indoor)	34-35	"SS", "SM"	618-200-03 61
Thermostats (Defrost)	35-36	"SL"	618-200-00 62
Resistor (Heat Anticipator)	36	"KS", "KM", "KL"	618-200-00 63
Capacitor, Run	36-37	"ES", "EM", "EL", "EK"	618-200-01 64
Check Valve	37	"YS13", "YM", "YL"	618-200-02 65
Heat Pump Reversing Valve	37-38	"YS09"	619-142-17 66
Solenoid Coil (Heat Pump Models)	38	Testing XQ and QME Boards	67
Valve, Drain Pan	38	Quick Reference Guide – QuietMaster	68
Heating Element	39	Quick Reference Guide – XStar	69
Sealed Refrigeration Repairs	39-40		

Typical Unit Components

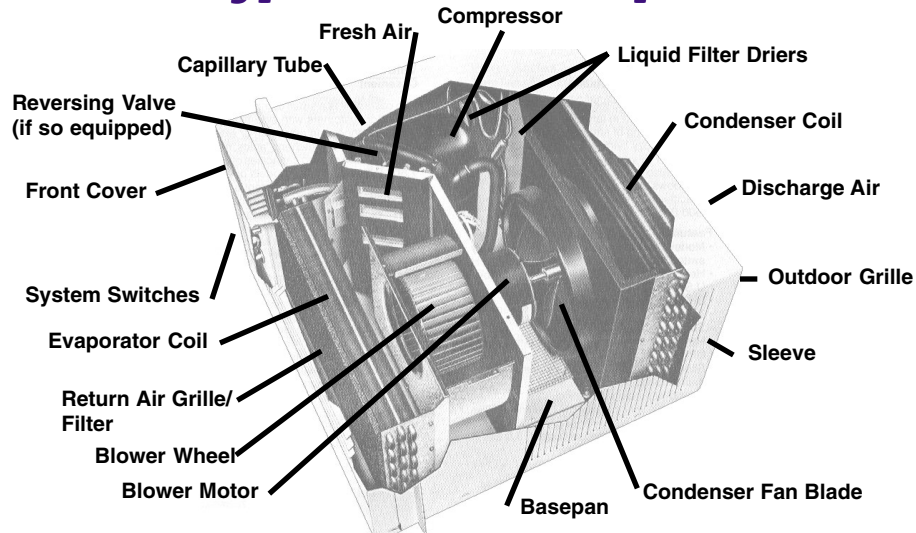

INTRODUCTION

This service manual is designed to be used in conjunction with the installation manuals provided with each air conditioning system component.

This service manual was written to assist the professional RAC service technician to quickly and accurately diagnose and repair malfunctions.

This manual will deal with subjects in a general nature. (i.e. All text will not pertain to all models).

IMPORTANT: It will be necessary for you to accurately identify the unit you are servicing, so you can be certain of a proper diagnosis and repair. (See Unit Identification.)

WARNING

The information contained in this manual is intended for use by a qualified service technician who is familiar with the safety procedures required in installation and repair, and who is equipped with the proper tools and test instruments.

Installation or repairs made by unqualified persons can result in hazards subjecting the unqualified person making such repairs to the risk of injury or electrical shock which can be serious or even fatal not only to them, but also to persons being served by the equipment.

If you install or perform service on equipment, you must assume responsibility for any bodily injury or property damage which may result to you or others. Friedrich Air Conditioning Company will not be responsible for any injury or property damage arising from improper installation, service, and/or service procedures.

Room Air Conditioner Specifications ENERGY STAR® Compliant												
Model	Cooling Capacity BTU/Hr.	Heating Capacity BTU/H	Volts Rated	Cooling Amps	Cooling Watts	Heating Amps	Heating Watts	Energy Efficiency Ratio E E R	Moisture Removal Pints/Hr.	Room Side Air Circulation CFM	* Sleeve Ø	Net Weight Lbs.
XSTAR®												
* XQ05J10	5400	–	115	4.6	507	–	–	10.7	1.5	160	Q	70
* XQ06J10	6200	–	115	5.1	564	–	–	11.0	2.0	160	Q	77
XQ07J10	7100	–	115	6.5	689	–	–	10.3	2.5	145	Q	80
XQ08J10	8250	–	115	4.5	842	–	–	9.8	2.5	165	Q	80
QSTAR®												
* SQ05J10B	5400	–	115	4.6	507	–	–	10.7	1.5	160	Q	70
* SQ06J10B	6200	–	115	5.1	564	–	–	11.0	2.0	160	Q	77
SQ08J10B	8250	–	115	7.5	842	–	–	9.8	2.5	165	Q	80
QSTAR®												
KQ05J10B	5000	–	115	4.7	516	–	–	9.7	1.5	165	Q	76
KQ06J10B	6000	–	115	5.4	592	–	–	10.1	2.0	165	Q	76
KQ058J10B	8250	–	115	7.5	842	–	–	9.8	2.5	165	Q	79
QuietMaster® Electronic												
* SS08J10R	8200	–	115	6.7	745	–	–	11.0	2.0	310	S	108
* SS09J10B	9200	–	115	7.2	800	–	–	11.5	1.7	300	S	113
* SS10J10R	10200	–	115	7.5	872	–	–	11.7	2.6	300	S	115
* SS12J10AR	11750	–	115	9.8	1068	–	–	11.0	3.5	325	S	114
* SS14J10R	14000	–	115	12.0	1308	–	–	10.7	3.7	400	M	128
SS12J30B	12000/12000	–	230/208	5.5/5.7	1143/1091	–	–	10.5/11.0	3.5	330	S	114
SS16J30	15600/15300	–	230/208	7.2/7.7	1598/1560	–	–	9.8/9.8	5.0	325	S	119
SM19J30R	13900/19000	–	230/208	8.9/9.6	1972/1926	–	–	9.8/9.9	5.7	330	M	163
SM12J30B	21000/20500	–	230/208	10.6/11.4	2333/2278	–	–	9.0/9.0	7.0	440	M	154
QuietMaster® Deluxe												
* RS10J10	1000	–	115	8.3	909	–	–	11.0	2.6	300	S	115
* RS12J10A	11700	–	115	9.8	1068	–	–	11.0	3.5	325	S	114
RS14J10	14200	–	115	12.0	1357	–	–	10.5	3.7	400	M	128
RS16J30	15600/15300	–	230/208	7.2/7.7	1598/1560	–	–	9.8/9.8	5.0	330	S	119
RS19J30	19300/19000	–	230/208	8.9/9.6	1972/1926	–	–	9.8/9.8	5.7	425	M	163
QuietMaster®												
KS10J10	1000	–	115	9.1	971	–	–	10.3	2.8	325	S	108
KS12J10	11500	–	115	10.5	1150	–	–	10.0	3.5	325	S	111
KS14J10	14000	–	115	12.0	1386	–	–	10.1	3.7	400	M	128
KS12J30A	12500/12500	–	230/208	5.8/6.2	1250/1205	–	–	10.0/10.0	3.5	325	S	106
KS18J30B	17600/17300	–	230/208	8.2/8.7	1820/1760	–	–	9.7/9.8	5.5	440	M	161
KM21J30	20500/20500	–	230/208	1.03/11.4	2278/2278	–	–	9.0/9.0	7.0	440	M	154
KL25J30A	25000/25000	–	230/208	12.3/13.6	2278/2278	–	–	9.0/9.0	7.7	560	L	192
QuietMaster® Heavy Duty												
* SL24J30A	24500/24500	–	230/208	11.9/13.0	2580/2605	–	–	9.5/9.4	7.7	560	L	192
SL28J30A	28000/27500	–	230/208	14.0/15.5	3110/3090	–	–	9.0/8.9	8.8	600	L	201
SL33J30	33000/32500	–	230/208	17.0/18.0	3665/3610	–	–	9.0/9.0	11.0	700	L	216
TwinTemp® Heat Pump												
YQ06J10A**	6200	5300	115	5.7	620	–	–	10.0	2.0	140	Q	78
Y309J10**	9000	8300	115	7.2	785	6.2	615	11.5	1.7	300	S	113
YS13J33	13000/13000	12400/12300	230/208	6.0/6.5	1327/1327	6.7	760	9.8/9.8	3.5	325	S	117
YM18J34A	17500/17500	16500/16300	230/208	8.3/9.0	1862/1862	6.0/6.5	1340/1300	9.4/9.4	5.2	425	M	166
YL24J35A	24000/23800	23000/22800	230/208	12.0/13.0	2665/2645	7.6/8.3	1720/1700	9.0/9.0	7.0	600	L	198
TwinTemp® Electric Heat												
ES12J33	12000/12000	10700/8900	230/208	5.5/5.7	1145/1090	10.4/11.5	2350/2340	10.5/11.0	3.5	325	S	111
ES12J33A	12500/12500	10700/8900	230/208	5.38/6.2	1250/1250	16.0/14.7	3500/2900	10.0/10.0	3.5	325	S	108
ES16J33	15600/15300	10700/8900	230/208	7.2/7.7	1598/1560	16.0/14.7	3500/2900	9.8/9.8	5.0	330	S	116
ES19J34	19300/19000	13000/10600	230/208	8.9/9.6	1972/1926	16.0/14.7	3500/2900	9.8/9.9	5.7	425	M	160
EK18J34B	17600/17300	13000/10600	230/208	8.2/8.7	1820/1760	19.5/17.0	4200/3500	9.7/9.8	5.5	440	M	158
EL24J35A	24500/24500	17300/14300	230/208	11.9/13.0	2580/2605	19.5/17.0	4200/3500	9.5/9.4	7.7	560	L	191
EL33J35	33000/33000	17300/14300	230/208	17.0/18.0	3665/3610	24.0/22.4	5500/4650	9.0/9.0	11.0	700	L	215
Casement												
SC06H10D	6200	–	115	6.7	715	24.0/22.4	5500/4650	8.7	2.0	140	SC	70

* Sleeve dimensions are listed on the following page.

** These heat pumps have no supplemental electric and should not be operated below 37F.

As an ENERGY STAR partner, Friedrich Air Conditioning co. has determined that the selected ENERGY STAR (M) models meet the ENERGY STAR requirements for energy efficiency.



WallMaster® Thru-the-wall Specifications

Model	Cooling Capacity BTU/Hr.	Heating Capacity BTU/H	Volts Rated	Cooling Amps	Cooling Watts	Heating Amps	Heating Watts	Energy Efficiency Ratio E E	Moisture Removal Pints/Hr.	Room Side Air Circulation CFM	Sleeve* S	Net Weight Lbs.
WS07A10D	7000	–	115	6.7	735	–	–	8.5	1.4	260	WSC	93
WS09A10D	9000	–	115	9.0	980	–	–	9.2	2.0	260	WSC	103
WS12A10D	11500	–	115	11.5	1280	–	–	9.0	2.9	290	WSC	112
WS09A30D	9000/8800	–	230/208	4.5/4.9	980/980	–	–	9.2/9.0	2.1	260	WSC	101
WS12A30D	11500/11300	–	230/208	5.7/6.3	1280/1255	–	–	9.0/9.0	2.9	290	WSC	109
WS13A30D	12500/12300	–	230/208	6.3/6.8	1435/1415	–	–	8.7/8.7	4.0	250	WSC	119
WY09A33D	9000/8800	8200/8200	230/208	4.5/4.8	1000/980	4.1/4.2	870/840	9.0/9.0	2.1	270	WSC	107
WY12A33E	11300/10900	10800/10500	230/208	5.8/6.2	1315/1280	5.4/5.7	1200/1165	8.6/8.5	2.9	290	WSC	116
WE09A33D	9000/8800	11000/9100	230/208	4.5/4.9	980/980	16.0/14.7	3550/2950	9.2/9.0	2.1	260	WSC	103
WE12A33D	11500/11300	11000/9100	230/208	5.7/6.3	1280/1255	16.0/14.7	3550/2950	9.0/9.0	2.9	290	WSC	111
WE13A33D	12500/12300	11000/9100	230/208	6.3/6.8	1435/1415	16.0/14.7	3550/2950	8.7/8.7	4.0	250	WSC	121

Installation Information / Sleeve Dimensions

Sleeve	Height	Width	Depth with Front	Depth Hood to Louvers	Minimum Extension Into Room	Minimum Extension Outside	Window Width		Thru-the-wall Finished Hole	
							Minimum	Maximum	Height	Width
Q	14"	19 3/4"	21 3/8"	8 1/2"	5 1/2"	10 3/4"	26"	42"	14 3/4"	20"
S	15 15/16"	25 15/16"	27 3/8"	9 3/4"	3 1/16"	16 15/16"	27 7/8"	42"	16 3/16"	26 3/16"
M	17 15/16"	25 15/16"	27 3/8"	8 3/4"	3 1/16"	16 15/16"	27 7/8"	42"	18 3/8"	26 3/16"
L	20 3/16"	28"	33 5/8"	16 1/2"	3 3/16"	18 15/16"	29 7/8"	42"	20 3/8"	28 1/4"
SC	10 13/16"	14 11/16"	27"	9 7/8"	2 1/2"	15 1/2"	14 3/4"	17 7/8"	11 1/8"	14 15/16"
WSC	16 3/4"	27"	23"	–	7 1/2"	9/16"	–	–	17 1/4"	27 1/4"

* Maximum Height

Unit Performance Sheets

SPECIFICATIONS	SQ05J10A-1	SQ06J10A-1	SQ07J10A-1	SQ08J10AB-1
BTUH (Cooling)	5400	6300	7100	8000
E.E.R. (Cooling)	11.0	10.8	10.3	10.0
Volts	115	115	115	115
Amperes (Cooling)	4.4	5.2	6.5	7.5
Total Watts (Cooling)	490	585	690	800
Hertz	60	60	60	60
Fuse / Breaker Size	15	15	15	15
Fan RPM	1115	1115	1115	1115
Evaporator Air CFM	160	160	140	165
Exhaust Air CFM	Yes	Yes	Yes	Yes
Dehumidification Pts / Hr.	1.5	2.0	2.5	2.5
Width	19¾	19¾	19¾	19¾
Height	14"	14"	14"	14"
Depth	21 ³ / ₈	21 ³ / ₈	21 ³ / ₈	21 ³ / ₈
Minimum Ext. into Room	5½	5½	5½	5½
Minimum Ext. to Outside	10¾	10¾	10¾	10¾
Net Weight (Lbs.)	76	78	79	82
Shipping Weight (Lbs.)	81	83	84	87

PERFORMANCE DATA* Cooling	EVAPORATOR AIR TEMP. °F.		OPERATING PRESSURES		ELECTRICAL RATINGS		R-22 REFRIG.	COMP. OIL
	DISCHARGE AIR	TEMP. DROP °F	SUCTION	DISCHARGE	AMPS	LOCKED ROTOR AMPS	CHARGE IN OZ.	CHARGE IN FLUID OZ.
**SQ05J10A-1	55.45	24.55	76.5	281	4.4	34.0	16.0 R-22	9.8
**SQ06J10A-1	51.45	28.55	75.5	262	5.2	35.0	15.7 R-22	9.8
**SQ07J10A-1	50.41	29.59	75.5	277	6.5	40.0	24.0 R-22	9.8
**SQ08J10AB-1	50.50	29.50	74.5	262	7.5	39.2	19.5 R-22	9.8

* Rating Conditions: 80°F Room Air Temperature and 50% Relative Humidity with 95°F Outside Air Temperature at 40% Relative Humidity.

** Use Sunisco 4GDID Refrigerant Oil or Atmos 60.

SPECIFICATIONS	KQ05J10A-1	KQ06J10A-1	KQ08J10A-1	YQ06J10A-1
	KQ05J10A-3	KQ06J10A-3		
BTUH (Cooling)	5300	6200	7900	6200
E.E.R. (Cooling)	9.0	9.5	9.5	10.0
Volts	115	115	115	115
Amperes (Cooling)	5.2	5.8	7.5	5.7
Total Watts (Cooling)	585	650	830	620
Hertz	60	60	60	60
Fuse/Breaker Size	15	15	15	15
Fan RPM	1075	1075	1075	1075
Evaporator Air CFM	165	165	165	140
Exhaust Air CFM	Yes	Yes	Yes	Yes
Dehumidification Pts/Hr	1.5	2.0	2.5	2.0
Width	19¾"	19¾"	19¾"	19¾"
Height	14"	14"	14"	14"
Depth	21¾"	21¾"	21¾"	21¾"
Minimum Ext. Into Room	5½"	5½"	5½"	5½"
Minimum Ext. to Outside	10¾"	10¾"	10¾"	10¾"
Net Weight	76	76	82	80
Shipping Weight	81	81	87	85

PERFORMANCE DATA* Cooling	EVAPORATOR AIR TEMP. °F.		OPERATING PRESSURES		ELECTRICAL RATINGS		R-22 REFRIG.	COMP. OIL
	DISCHARGE AIR	TEMP. DROP °F	SUCTION	DISCHARGE	AMPS	LOCKED ROTOR AMPS	CHARGE IN OZ.	CHARGE IN FLUID OZ.
**KQ05J10A-1	56.34	23.66	76.5	265	5.2	29.0	12.0 R-22	9.8
**KQ05J10-3	56.34	23.66	76.5	265	5.2	29.0	13.5 R-22	9.8
**KQ06J10A-1	58.02	21.98	72.5	265	5.8	35.0	14.5 R-22	9.8
**KQ06J10A-3	58.02	21.98	72.5	265	5.8	35.0	13.0 R-22	9.8
**KQ08J10A-1	51.43	28.57	75.5	265	7.5	39.2	18.0 R-22	9.8
**YQ06J10A-1	54.10	25.90	74.5	260	5.7	39.2	19.0 R-22	9.8

* Rating Conditions: 80°F Room Air Temperature and 50% Relative Humidity with
95°F Outside Air Temperature at 40% Relative Humidity.

** Use Sunisco 4GDID Refrigerant Oil or Atmos 60.

SPECIFICATIONS	SC06H10D
BTUH (Cooling)	5950
E.E.R. (Cooling)	8.0
Volts	115
Amperes (Cooling)	6.8
Total Watts (Cooling)	760
Hertz	60
Fuse/Breaker Size	15
Fan RPM	1595
Evaporator Air CFM	125
Dehumidification Pts/Hr	2.0
Width	14 ^{11/16} "
Height	10 ^{13/16} "
Depth	27"
Minimum Ext. Into Room	2 ^{1/2} "
Minimum Ext. To Outside	15 ^{1/2} "
Net Weight	70
Shipping Weight	80

PERFORMANCE DATA*		SC06H10D
EVAPORATOR AIR TEMP. °F	DISCHARGE AIR	56.1
	TEMP DROP °F	23.9
OPERATING PRESSURES	SUCTION	72
	DISCHARGE	293
ELECTRICAL RATINGS	AMPS	6.8
	LOCKED ROTOR AMPS	35.0
R-22 REFRIG.	CHARGE IN OUNCES	14
COMP. OIL	CHARGE IN FLUID OZ.	9.8

* Rating Conditions:
80°F Room Air Temperature and 50% Relative Humidity with
95°F Outside Air Temperature at 40% Relative Humidity.

PERFORMANCE DATA Heating	VOLTS	BTUH	CFM HIGH SPEED	HEAT RISE
YQ06J10A	115	5300	140	35.0

PERFORMANCE DATA					
Heating					
YQ06J10A-1					
CONDITIONS	BTUH	EVAPORATOR AIR TEMP. RISE	AMPERES	WATTS	SUCTION/HEAD PRESSURE
70°F Inside 62°F Outside	6200	41.0	6.7	670	65/295
70°F Inside 57°F Outside	5900	39.0	6.5	650	61/285
70°F Inside 52°F Outside	5600	37.0	6.4	630	58/275
AHAM 70°F Inside 47°F Outside	5300	35.0	6.2	615	55/265
70°F Inside 45°F Outside	5200	34.4	6.1	610	53/260
70°F Inside 42°F Outside	5000	33.1	6.0	595	51/255

SPECIFICATIONS	KM14J10B1	KS10J10-1 KS10J10-3	KS12J10-1 KS12J103	KS12J30A1 KS12J30A3	KM18J30A2 KM18J30A3	KM21J304	KL21J30A3 KL25J30A1
	BTUH	14000	10000	12000	12500 12500	18000 18000	21000 20500
E.E.R.	10.1	10.3	9.5	10.0 10.0	9.6 9.6	9.0 9.0	8.3 8.2
Volts	115	115	115	230 208	230 208	230 208	230 208
Amperes	12.0	9.1	10.8	5.8 6.2	8.3 9.1	10.5 11.3	13.5 15.0
Total Watts	1385	970	1265	1250 1250	1875 1875	2335 2280	3010 3010
Hertz	60	60	60	60	60	60	60
Fuse/Breaker Size	15	15	15	15	15	15	20
Fan RPM	1180	1115	1080	1180	1120	1120	1120
Evaporator Air CFM	400	325	325	325	440	535	610
Fresh Air CFM	Yes	Yes	Yes	Yes	Yes	Yes	Yes
Exhaust Air CFM	Yes	Yes	Yes	Yes	Yes	Yes	Yes
Dehumidification Pts/HR	3.7	2.8	3.5	3.5	5.5	6.3	7.6
Width	25-15/16"	25-15/16"	25-15/16"	25-15/16"	25-15/16"	25-15/16"	28"
Height	17-15/16"	15-15/16"	15-15/16"	15-15/16"	17-15/16"	17-15/16"	20-3/16"
Depth	27-3/8"	27-3/8"	27-3/8"	27-3/8"	27-3/8"	27-3/8"	33-5/8"
Minimum Ext. Into Room	3-1/16"	3-1/16"	3-1/16"	3-1/16"	3-1/16"	3-3/16"	3-3/16"
Minimum Ext. to Outside	16-15/16"	16-15/16"	16-15/16"	16-15/16"	16-15/16"	16-15/16"	18-15/16"
Net Weight	128	108	111	111	136	183	190
Shipping Weight	138	118	121	121	148	203	210

PERFORMANCE DATA* Cooling	EVAPORATOR AIR TEMP. °F.		OPERATING PRESSURES		ELECTRICAL RATINGS		R-22 REFRIG.	COMP. OIL
	DISCHARGE AIR	TEMP. DROP °F	SUCTION	DISCHARGE	AMPS	LOCKED ROTOR AMPS	CHARGE IN OZ.	CHARGE IN FLUID OZ.
KS10J101, KS10J103	61.0	19.0	79.0	269	9.1	48.3	21.0	11.8
KS12J101, KS12J103	57.0	23.0	78.0	288	10.8	54.0	25.0	11.8
KS12J30A1, KS12J30A3	57.0	23.0	79.0	293	5.8 6.2	26.3	26.5/24.0	11.8
KM14J10B1	54.78	22.52	75.0	280	12.0	67.0	40.0	32.0
KM18J30A2 KM18J30A3	56.0	24.0	73.0	262	8.3 9.1	42.0	42.0	13.9
KM21J304	56.0	24.0	75.0	260	10.5 11.3	56.0	46.0	32.0
KL25J30A1, KL25J30A3	55.0	25.0	68.5	300	13.5 15.0	71.0	53/57	32.0

* Rating Conditions: 80°F. Room Air Temperature and 50% Relative Humidity with
95°F. Outside Air Temperature at 40% Relative Humidity.

SPECIFICATIONS	RS10J101	RS10J103	RS12J101	RS12J103	RS15J301	RM15J101	RM18J302	RM18J303
BTUH	10,000	10,000	12,000	12,000	15,000 15,000	14,500	18,500 18,300	18,500 18,300
E.E.R.	11.0	11.0	10.5	10.5	9.6	10.5	10.0 10.0	10.0 10.0
Volts	115	115	115	115	230 208	115 208	230 208	230 208
Amperes	8.3	8.3	10.2	10.2	6.9 7.5	12.0	8.4 9.0	8.4 9.0
Total Watts	910	910	1145	1145	1565 1565	1380 1380	1850 1830	1850 1830
Hertz	60	60	60	60	60	60	60	60
Fuse/Breaker Size	15	15	15	15	15	15	15	15
Fan RPM	1180	1180	1115	1115	1080	1180	1120	1120
Evaporator Air CFM	300	300	325	325	330	400	425	425
Fresh Air CFM	Yes	Yes	Yes	Yes	Yes	Yes	Yes	Yes
Exhaust Air CFM	Yes	Yes	Yes	Yes	Yes	Yes	Yes	Yes
Dehumidification Pts/HR	2.6	2.6	3.5	3.5	5.0	3.7	5.7	5.7
Width	25-15/16"	25-15/16"	25-15/16"	25-15/16"	25-15/16"	25-15/16"	25-15/16"	25-15/16"
Height	15-15/16"	15-15/16"	15-15/16"	15-15/16"	15-15/16"	17-15/16"	17-15/16"	17-15/16"
Depth	27-3/8"	27-3/8"	27-3/8"	27-3/8"	27-3/8"	27-3/8"	27-3/8"	27-3/8"
Minimum Ext. Into Room	3-1/16"	3-1/16"	3-1/16"	3-1/16"	3-1/16"	3-1/16"	3-1/16"	3-1/16"
Minimum Ext. to Outside	16-15/16"	16-15/16"	16-15/16"	16-15/16"	16-15/16"	16-15/16"	16-15/16"	16-15/16"
Net Weight	115	115	114	114	11.9	128	163	163
Shipping Weight	125	125	124	125	128	138	173	173

PERFORMANCE DATA* Cooling	EVAPORATOR AIR TEMP. °F.		OPERATING PRESSURES		ELECTRICAL RATINGS		R-22 REFRIG.	COMP. OIL
	DISCHARGE AIR	TEMP. DROP °F	SUCTION	DISCHARGE	AMPS	LOCKED ROTOR AMPS	CHARGE IN OZ.	CHARGE IN FLUID OZ.
RS10J10-1, RS10J10-3	61.0	19.0	79.0	269	7.5	44.0	25/24	11.8
RS12J10, RS12J10-3	57.0	23.0	78.0	266	10.2	54.0	25.0	11.8
RS15J301	57.0	23.0	72.0	293	6.9 7.5	42.0	32.0	11.8
RM18J302, RM18J303	56.0	24.0	73.0	262	8.3 9.1	42.0	47/43	13.9
RM15J10-1	56.35	23.65	74.0	260	11.4	67.0	40.0	11.8

* Rating Conditions: 80°F. Room Air Temperature and 50% Relative Humidity with 95°F. Outside Air Temperature at 40% Relative Humidity.

SPECIFICATIONS		YS09J10-1	YS13J33-1	YM18J34A-2	YL24J35A-1
BTUH (Cooling)		9000	13000	17500	24000
BTUH (Heating)		8300	13000 12400	17500 16500	23800 23000
E.E.R. (Cooling)		11.5	9.8	9.4	9.0
E.E.R. (Heating)		11.0	9.8 9.4	9.4 9.6	9.0 9.8
Volts		115	230 208	230 208	230 208
Amperes (Cooling)		7.2	6.0	8.3	12.0
Amperes (Heating)		6.7	6.5 6.0	9.1 7.6	13.0 10.4
Total Watts (Cooling)		760	1325 1325	1860 1860	2665 2645
Hertz		60	60	60	60
Fuse/Breaker Size		15	20	30	30
Amps			16.0 14.7	19.5 17.0	24.0 22.4
Watts			3500 2900	4200 3500	5500 4650
Resistance Heater	BTUH		10700 8900	13000 10600	17300 14300
		1110	1110	1120	1120
		300	325	425	600
		Yes	Yes	Yes	Yes
	Denominations (1/3)/Hr	1.7	3.5	5.2	7.0
Width		25 15/16"	25 15/16"	25 15/16"	28"
Height		15 15/16"	15 15/16"	17 15/16"	20 3/16"
Depth		27 3/8"	27 3/8"	27 3/8"	33 5/8"
Minimum Ext. Into Room		31 1/16"	31 1/16"	31 1/16"	33 1/16"
Minimum Ext. to Outside		16 15/16"	16 15/16"	16 15/16"	18 15/16"
Net Weight		113	117	166	198
Shipping Weight		124	128	153	217

PERFORMANCE DATA* Cooling	EVAPORATOR AIR TEMP. °F.		OPERATING PRESSURES		ELECTRICAL RATINGS		R-22 REFRIG.	COMP. OIL
	DISCHARGE AIR	TEMP. DROP °F	SUCTION	DISCHARGE	AMPS	LOCKED ROTOR AMPS	CHARGE IN OZ.	CHARGE IN FLUID OZ.
	YS09J10-1	59.0	21.0	87.0	241	7.2	39.2	28.0
YS13J33-1	56.0	24.0	75.0	280	6.0 6.5	29.0	30.0	11.8
YM18J34A-2	53.0	27.0	74.0	277	8.7 9.3	42.0	54.0	30.0
YL24J35A-1	55.0	25.0	77.0	272	12.0 13.0	61.0	69.0	32.0

* Rating Conditions: 80°F Room Air Temperature and 50% Relative Humidity with 95°F Outside Air Temperature at 40% Relative Humidity.

PERFORMANCE DATA (Heating)	*YS09J10-1	**YS13J33-1	**YM18J34A-2	**YL24J35A-1
AHAM @ 70°F Inside 47°F Outside @ 70°F Inside 35°F Outside	8300	12400/12300 10700/8900	17200/17200 13000/10600	23000/22800 17300/14300
Evaporator Air Temperature Rise @ 70°F Inside 47°F Outside @ 70°F Inside 35°F Outside	19.62	31.38 28.69/23.87	24.74 24.46/20.22	31.71 24.38/20.16
AMPS @ 70°F Inside 47°F Outside @ 70°F Inside 35°F Outside	6.7	6.0/6.5 16.0/14.7	8.5/9.0 19.5/17.0	10.4/11.5 24.0/22.4
Watts @ 70°F Inside 47°F Outside @ 70°F Inside 35°F Outside	760	1340/1300 3500/2900	1880/1820 5500/4650	2350/2340 5500/4650
Suction/Head PSIG @ 70°F Inside 47°F Outside	53.5/222	52.5/251	53/225	54/236.5

* Do not operate below 37° ambient.

** Heating element comes on at 35°F outside ambient and compressor shuts off.

SPECIFICATIONS	ES12J33-1	ES15J33A-1	EM18J34A-2	EL24J35A-1	EL33J35-2	EK12J33A-1	EK18J34A-2
	ES12J33-3		EM18J34A-3	EL24J35A-2		EK12J33A-3	EK18J34A-3
BTUH (Cooling)	12000 12000	15000 15000	18500 18300	24000 24000	33000 32500	12500 12500	18000 18000
BTUH (Heating)	10700 8900	10700 8900	13000 10600	17300 14300	17300 14300	10700 8900	13000 10600
E.E.R. (Cooling)	10.5 11.0	9.6 9.6	10.0 10.0	9.5 9.4	9.0 9.0	10.0 10.0	9.6 9.6
E.E.R. (Heating)							
Volts	230 208	230 208	230 208	230 208	230 208	230 208	230 208
Amperes (Cooling)	5.5 5.7	6.9 7.5	8.4 9.0	12.0 13.3	17.0 18.0	5.8 6.2	8.3 9.1
Amperes (Heating)	16.0 14.7	16.0 14.7	19.5 17.0	24.0 22.4	24.0 22.4	16.0 14.7	19.5 17.0
Total Watts (Cooling)	1145 1090	1665 1655	1850 1830	2610 2640	3670 3610	1250 1250	1875 1875
Hertz	60	60	60	60	60	60	60
Fuse/Breaker Size	20	20	30	30	30	20	30
Fan RPM	1120	1100	1120	1100	1100	1080	1120
Evaporator Air CFM	325	330	425	560	700	325	440
Fresh Air CFM	Yes	Yes	Yes	Yes	Yes	Yes	Yes
Exhaust Air CFM	Yes	Yes	Yes	Yes	Yes	Yes	Yes
Dehumidification Pts/Hr	3.5	5.0	5.7	7.7	11.0	3.5	5.5
Width	25 15/16"	25 15/16"	25 15/16"	28"	28"	25 15/16"	25 15/16"
Height	15 15/16"	15 15/16"	17 15/16"	20 3/16"	20 3/16"	15 15/16"	17 15/16"
Depth	27 3/8"	27 3/8"	27 3/8"	33 5/8"	33 5/8"	27 3/8"	27 3/8"
Minimum Ext. Into Room	3 1/16"	3 1/16"	3 1/16"	3 3/16"	3 3/16"	3 1/16"	3 1/16"
Minimum Ext. to Outside	16 15/16"	16 15/16"	16 15/16"	18 15/16"	18 15/16"	16 15/16"	16 15/16"
Net Weight	111	116	160	191	215	108	158

PERFORMANCE DATA* Cooling	EVAPORATOR AIR TEMP. °F.		OPERATING PRESSURES		ELECTRICAL RATINGS		R-22 REFRIG.	COMP. OIL
	DISCHARGE AIR	TEMP. DROP °F	SUCTION	DISCHARGE	AMPS	LOCKED ROTOR AMPS	CHARGE IN OZ.	CHARGE IN FLUID OZ.
	ES12J33-1 ES12J33-3	58.0	22.0	77.5	266	5.5 5.7	26.3 26.3	25.0 26.0
ES15J33A-1	53.0	27.0	77.0	260	7.4 8.2	42.0	32.0	30.0
EM18J34A-2 EM18J34A-3	55.0	25.0	73.0	262	8.2 8.7	42.0 42.0	47.0 43.0	30.0 30.0
EL24J35A-1 EL24J35A-3	55.0	25.0	73.5	280	12.0 13.3	61.0	53.0 57.0	32.0 32.0
EL33J35-2	52.0	28.0	71.0	299	17.0 18.0	94.0	78.0	35.0
EK12J33A-1 EK12J33A-3	57.0	23.0	79.0	293	5.8 6.2	26.3 26.3	26.5 24.0	11.8 11.8
EK18J34A-2 EK18J34A-3	55.0	25.0	73.0	262	8.2	42.0 42.0	46.0 42.0	30.0 30.0

* Rating Conditions: 80°F Room Air Temperature and 50% Relative Humidity with 95°F Outside Air Temperature at 40% Relative Humidity.

PERFORMANCE DATA Heating	VOLTS	BTUH	CFM HIGH SPEED	HEAT RISE
ES12J33-1 ES12J33-3	230 208	10700 8900	1120	30.5
ES15J33A-1	230 208	10700 8900	1100	30.5
EM18J34A-2 EM18J34A-1	230	13000 208	1120 10600	28.3
EL24J35A-1 EL24J35A-3	230	17300 208	1100 14300	28.6
EL33J35	230 208	17300 14300	1110	22.8
EK12J33A-1 EK12J33A-3	230	10700 208	1080 8900	30.5
EK18J34A-2 EK18J34A-3	230 208	13000 10600	1120	27.5

SPECIFICATIONS	SS08J10R1 SS08J10A1	SS09J10A1	SS10J10R1 SS10J10A1	SS12J10R1 SS12J10A1 SS12J10A3	SS12J30A1 SS12J30A
BTUH	8200	9200	10200	12000	12000 12000
E.E.R.	10.8	11.55	11.7	10.5	10.5
Volts	115	115	115	115	230/208
Amperes	6.7	7.2	7.5	10.2	5.5/5.7
Total Watts	745	800	870	1145	1145 1090
Hertz	60	60	60	60	60
Fuse/Breaker Size	15	15	15	15	15
Fan RPM	1110	1110	1095	1120	1110
Evaporator Air CFM	310	300	300	325	325
Fresh Air CFM	Yes	Yes	Yes	Yes	Yes
Exhaust Air CFM	Yes	Yes	Yes	Yes	Yes
Dehumidification Pts/HR	2.0	1.7	2.6	3.5	3.5
Width	25-15/16"	25-15/16"	25-15/16"	25-15/16"	25-15/16"
Height	15-15/16"	15-15/16"	15-15/16"	15-15/16"	15-15/16"
Depth	27-3/8"	27-3/8"	27-3/8"	27-3/8"	27-3/8"
Minimum Ext. Into Room	3-1/16"	3-1/16"	3-1/16"	3-1/16"	3-3/16"
Minimum Ext. to Outside	16-15/16"	16-15/16"	16-15/16"	16-15/16"	16-15/16"
Net Weight	108	113	115	114	114
Shipping Weight	118	123	125	127	2127

PERFORMANCE DATA* Cooling	EVAPORATOR AIR TEMP. °F.		OPERATING PRESSURES		ELECTRICAL RATINGS		R-22 REFRIG.	COMP. OIL
	DISCHARGE AIR	TEMP. DROP °F	SUCTION	DISCHARGE	AMPS	LOCKED ROTOR AMPS	CHARGE IN OZ.	CHARGE IN FLUID OZ.
SS08J10R1 SS08J10A-1	61.4	18.6	86.5	262	6.7	33.0	24	11.8
SS09J10A-1	57.8	22.2	84.0	251	7.2	39.2	26.0	11.8
SS10J10R-1 SS10J10A-1	57.22	22.78	77.5	266	10.2	54.0	32.0	11.8
SS12J10R-1 SS12J10A-1	57.22	22.78	77.5	266	10.2	54.0	25.0	11.8
SS12J10A-3 SS12J30A-1 SS12J30A-3	57.2	22.8	77.0	260	5.5 5.7	56.3	26.0	11.8

* Rating Conditions: 80°F. Room Air Temperature and 50% Relative Humidity with 95°F. Outside Air Temperature at 40% Relative Humidity.

SPECIFICATIONS	SM14J10B1	SS15J30A1	SM18J30A2	SM21J30A4	SL24J30A3	SL28J30A	SL33J302
			SM18J30A3		SL24J30A1		
BTUH	14000	15000 15000	18200 18000	21000 20500	24000 24000	28000 27500	33000 32500
E.E.R.	10.5	9.6 9.6	10.0 10.0	9.0 9.0	9.1 8.9	8.9 9.0	9.0 9.0
Volts	115	230 208	230 208	230 208	230 208	230 208	230 208
Amperes	12.0	6.9 7.5	8.4 9.0	10.6 11.4	12.0 13.3	14.0 15.5	17.0 18.0
Total Watts	1335	1565 1555	1850 1830	2333 2278	2610 2640	3110 3090	3670 3640
Hertz	60	60	60	60	60	60	60
Fuse/Breaker Size	15	15	15	20	20	20	20
Fan RPM	1110	1110	1120	1120	1100	1100	1110
Evaporator Air CFM	400	325	425	440	560	600	700
Fresh Air CFM	Yes	Yes	Yes	Yes	Yes	Yes	Yes
Exhaust Air CFM	Yes	Yes	Yes	Yes	Yes	Yes	Yes
Dehumidification Pts/HR	3.7	5.0	5.7	7.0	7.7	8.8	11.0
Width	25-15/16"	25-15/16"	25-15/16"	25-15/16"	28"	28"	28"
Height	17-15/16"	15-15/16"	17-15/16"	17-15/16"	20-3/16"	20-3/16"	20-3/16"
Depth	27-3/8"	27-3/8"	27-3/8"	27-3/8"	33-5/8"	33-5/8"	33-5/8"
Minimum Ext. Into Room	3-1/16"	3-1/16"	3-1/16"	3-3/16"	3-3/16"	3-3/16"	3-3/16"
Minimum Ext. to Outside	16-15/16"	16-15/16"	16-15/16"	16-15/16"	18-15/16"	18-15/16"	18-15/16"
Net Weight	128	124	138	183	192	201	216
Shipping Weight	140	134	150	203	212	221	236

PERFORMANCE DATA* Cooling	EVAPORATOR AIR TEMP. °F.		OPERATING PRESSURES		ELECTRICAL RATINGS		R-22 REFRIG.	COMP. OIL
	DISCHARGE AIR	TEMP. DROP °F	SUCTION	DISCHARGE	AMPS	LOCKED ROTOR AMPS	CHARGE IN OZ.	CHARGE IN FLUID OZ.
SM14J10B1	56.34	23.66	84.0	245	12.0	67.0	40.0	14.3
SS15J30A1	54.35	25.65	72.0	292	6.9 7.5	42.0	32.0	13.9
SM18J30A2, SM18J30A3	54.56	25.44	74.0	265	8.4 9.0	33.0	47.0 43.0	11.8
SM21J30A4	52.58	27.42	75	290	10.6 11.4	61	46	32.0
SL24J30A1. SM24J30A3	54.86	25.14	73.5	280	12.0 13.3	61.0	53. 57.0	32.0
SL28J30A1	52.32	27.68	74.0	291	14.0 15.5	69.5	87.0	32.0
SL33J302	52.93	27.07	71.0	299	17.0 18.0	94.0	78	35.0

* Rating Conditions: 80°F. Room Air Temperature and 50% Relative Humidity with 95°F. Outside Air Temperature at 40% Relative Humidity.

SPECIFICATIONS	WS07A10D	WS09A10D	WS12A10D	WS09A30D	WS12A30D	WS13A30D
BTUH	7000	9000	11500	9000 8800	11500 11300	12500 12300
E.E.R.	9.5	9.2	9.0	9.2 9.0	9.0 9.0	8.7 8.7
Volts	115	115	115	230 208	230 208	230 208
Amperes	6.7	9.0	11.5	4.5 4.9	5.7 6.3	6.3 6.8
Total Watts	740	980	1280	980 980	1280 1255	1440 1415
Hertz	60	60	60	60	60	60
Fuse/Breaker Size	15	15	15	15	15	15
Fan RPM	1145	1140	1275	1140	1275	1275
Evaporator Air CFM	260	260	290	260	290	250
Fresh Air CFM						
Exhaust Air	Yes	Yes	Yes	Yes	Yes	Yes
Dehumidification Pts/Hr	1.4	2.1	2.9	2.1	2.9	4.0
Width	27"	27"	27"	27"	27"	27"
Height	16-3/4"	16-3/4"	16-3/4"	16-3/4"	16-3/4"	16-3/4"
Depth	16-3/4"	16-3/4"	16-3/4"	16-3/4"	16-3/4"	16-3/4"
Minimum Ext. Into Room	7-1/2"	7-1/2"	7-1/2"	7-1/2"	7-1/2"	7-1/2"
Minimum Ext. To Outside	9/16"	9/16"	9/16"	9/16"	9/16"	9/16"
Net Weight	75	85	94	83	91	101
Shipping Weight	93	103	112	101	109	119

PERFORMANCE DATA* Cooling	EVAPORATOR AIR TEMP. °F.		OPERATING PRESSURES		ELECTRICAL RATINGS		R-22 REFRIG.	COMP. OIL
	DISCHARGE AIR	TEMP. DROP °F.	SUCTION	DISCHARGE	AMPS	LOCKED ROTOR AMPS	CHARGE IN OUNCES	CHARGE IN FLUID OZ.
WS07A10D	59.5	19.5	82	280	6.7	32.0	19	11.8
WS09A10D	58.0	22.0	82	295	9.0	44.0	20	11.8
WS12A10D	55.0	25.0	76	295	11.5	54.0	36	11.8
WS09A30D	58.0	22.0	80	295	4.5 4.9	20.0	20	11.8
WS12A30D	55.0	25.0	76	295	5.7 6.3	26.3	36	11.8
WS13A30D	47.1	32.9	73	308	6.3 6.8	33.0	38	11.8

*Rating Conditions: 80°F. Room Air Temperature and 50% Relative Humidity with 95°F. Outside Air Temperature at 40% Relative Humidity.

SPECIFICATIONS	WE09A33D	WE12A33D	WE13A33D	WY09A33D	WY12A33E
BTUH (Cooling)	9000	11500	12500	9000	11300
	8800	11300	12300	8800	10900
BTUH (Heating)	11000	11000	11000	8200	10800
	9100	9100	9100	8200	10500
E.E.R. (Cooling)	9.2	9.0	8.7	9.0	8.6
	9.0	9.0	8.7	9.0	8.5
E.E.R (Heating)				9.0	9.0
				9.8	9.0
Volts	230	230	230	230	230
	208	208	208	208	208
Amperes (Cooling)	4.5	5.7	6.3	4.5	5.8
	4.9	6.3	6.8	4.8	6.2
Amperes (Heating)	16.0	16.0	16.0	3.8	5.4
	14.7	14.7	14.7	4.1	5.7
Total Watts (Cooling)	480	1280	1440	1000	1315
	980	1255	1415	980	1280
Total Watts (Heating)	3550	3550	3550	870	1200
	2950	2950	2950	840	1165
Hertz	60	60	60	60	60
Fuse/Breaker Size	20	20	20	20	20
Resistance Heater	Amps			16.0	16.0
				14.7	14.7
	Watts			3550	3550
				2950	2950
BTUH			11000	11000	
			9100	9100	
Fan RPM	1140	1275	1275	1140	1275
Evaporator Air CFM	260	290	250	270	290
Fresh Air CFM					
Exhaust Air CFM	Yes	Yes	Yes	Yes	Yes
Dehumidification Pts/Hr	2.1	2.9	4.0	2.1	2.9
Width	27"	27"	27"	27"	27"
Height	16-3/4"	16-3/4"	16-3/4"	16-3/4"	16-3/4"
Depth	16-3/4"	16-3/4"	16-3/4"	16-3/4"	16-3/4"
Minimum Ext. Into Room	7-1/2"	7-1/2"	7-1/2"	7-1/2"	7-1/2"
Minimum Ext. To Outside	9/16"	9/16"	9/16"	9/16"	9/16"
Net Weight	84	92	102	86	94
Shipping Weight	103	111	121	107	116

PERFORMANCE DATA* Cooling	EVAPORATOR AIR TEMP. °F.		OPERATING PRESSURES		ELECTRICAL RATINGS		R-22 REFRIG.	COMP. OIL
	DISCHARGE AIR	TEMP. DROP °F.	SUCTION	DISCHARGE	AMPS	LOCKED ROTOR AMPS	CHARGE IN OUNCES	CHARGE IN FLUID OZ.
WE09A33D	58.0	22.0	80	295	4.5 4.9	20.0	20	11.8
WE12A33D	55.0	25.0	76	295	5.7 6.3	26.3	36	11.8
WE13A33D	47.1	32.9	73	308	6.3 6.8	33.0	38	11.8
WY09A33D	58.0	22.0	80	295	4.5 4.8	20.0	26	11.8
WY12A33E	55.0	25.0	76	295	5.8 6.2	26.3	43	11.8

*Rating Conditions: 80°F. Room Air Temperature and 50% Relative Humidity with
95°F. Outside Air Temperature at 40% Relative Humidity.

PERFORMANCE DATA (Heating)	VOLTS	BTUH	CFM HIGH SPEED	HEAT RISE
WE09A33D	230	11000	260	39.0
	208	9100		
WE12A33D	230	11000	290	35.0
	208	9100		
WE13A33D	230	11000	250	40.0
	208	9100		

PERFORMANCE DATA (Heating)		*WY09A33D	*WY12A33E
BTUH	@70°F Inside 62°F Outside	9700	12400
	@70°F Inside 57°F Outside	9300	12000
	@70°F Inside 52°F Outside	8800	11400
	** @70°F Inside 47°F Outside	8200/8100	10800/10400
	@70°F Inside 42°F Outside	7600	10000
	@70°F Inside 37°F Outside	6800	9000
	@70°F Inside 35°F Outside	11000/9100	11000/9100
	Evaporator Air Temperature Rise		
	@70°F Inside 62°F Outside	32.00	37.60
	@70°F Inside 57°F Outside	30.75	36.40
	@70°F Inside 52°F Outside	29.10	34.50
	** @70°F Inside 47°F Outside	27.10/26.80	32.70/31.50
	@70°F Inside 42°F Outside	25.10	30.30
	@70°F Inside 37°F Outside	22.50	27.30
	@70°F Inside 35°F Outside	36.40/30.10	33.30/27.60
	AMPS	@70°F Inside 62°F Outside	4.0
@70°F Inside 57°F Outside		3.9	5.5
@70°F Inside 52°F Outside		3.85	5.4
** @70°F Inside 47°F Outside		3.8/4.1	5.3/5.6
@70°F Inside 42°F Outside		3.6	5.1
@70°F Inside 37°F Outside		3.4	4.8
@70°F Inside 35°F Outside		16.0/14.7	16.0/14.7
Watts		@70°F Inside 62°F Outside	880
	@70°F Inside 57°F Outside	870	1260
	@70°F Inside 52°F Outside	860	1220
	** @70°F Inside 47°F Outside	835/810	1175/1155
	@70°F Inside 42°F Outside	800	1130
	@70°F Inside 37°F Outside	760	1070
	@70°F Inside 35°F Outside	3550/2950	3550/2950
	Suction/Head PSIG		
	@70°F Inside 62°F Outside	66/315	61/325
	@70°F Inside 57°F Outside	62/285	59/290
	@70°F Inside 52°F Outside	57/285	53/275
	** @70°F Inside 47°F Outside	53/265	49/255
	@70°F Inside 42°F Outside	49/215	45/240
	@70°F Inside 37°F Outside	45/203	41/220
	@70°F Inside 35°F Outside	44/200	40/215

* Heating Element comes on at 35°F outside ambient and compressor shuts off.

** AHAM Rating Conditions.

Refrigeration System Sequence of Operation

A good understanding of the basic operation of the refrigeration system is essential for the service technician. Without this understanding, accurate troubleshooting of refrigeration system problems will be more difficult and time consuming, if not (in some cases) entirely impossible. The refrigeration system uses four basic principles (laws) in its operation they are as follows:

1. "Heat always flows from a warmer body to a cooler body."
2. "Heat must be added to or removed from a substance before a change in state can occur"
3. "Flow is always from a higher pressure area to a lower pressure area."
4. "The temperature at which a liquid or gas changes state is dependent upon the pressure."

The refrigeration cycle begins at the compressor. Starting the compressor creates a low pressure in the suction line which draws refrigerant gas (vapor) into the compressor. The compressor then "compresses" this refrigerant, raising its pressure and its (heat intensity) Temperature.

The refrigerant leaves the compressor through the discharge line as a hot high pressure gas (vapor). The refrigerant enters the condenser coil where it gives up some of its heat. The condenser fan moving air across the coil's finned surface facilitates the transfer of heat from the refrigerant to the relatively cooler outdoor air.

When a sufficient quantity of heat has been removed from the refrigerant gas (vapor), the refrigerant will "condense" (i.e. change to a liquid). Once the refrigerant has been condensed (changed) to a liquid it is cooled even further by the air that continues to flow across the condenser coil.

The RAC design determines at exactly what point (in the condenser) the change of state (i.e. gas to a liquid) takes place. In all cases, however, the refrigerant must be totally condensed (changed) to a liquid before leaving the condenser coil.

The refrigerant leaves the condenser coil through the liquid line as a warm high pressure liquid. It next will pass through the refrigerant drier (if so equipped). It is the function of the drier to trap any moisture present in the system, contaminants, and large particulate matter.

The liquid refrigerant next enters the metering device. The metering device is a capillary tube. The purpose of the metering device is to "meter" (i.e. control or measure) the quantity of refrigerant entering the evaporator coil.

In the case of the capillary tube this is accomplished (by design) through size (and length) of device, and the pressure difference present across the device.

Since the evaporator coil is under a lower pressure (due to the suction created by the compressor) than the liquid line, the liquid refrigerant leaves the metering device entering the evaporator coil. As it enters the evaporator coil, the larger area and lower pressure allows the refrigerant to expand and lower its temperature (heat intensity). This expansion is often referred to as "boiling". Since the unit's blower is moving Indoor air across the finned surface of the evaporator coil, the expanding refrigerant absorbs some of that heat. This results in a lowering of the indoor air temperature, hence the "cooling" effect.



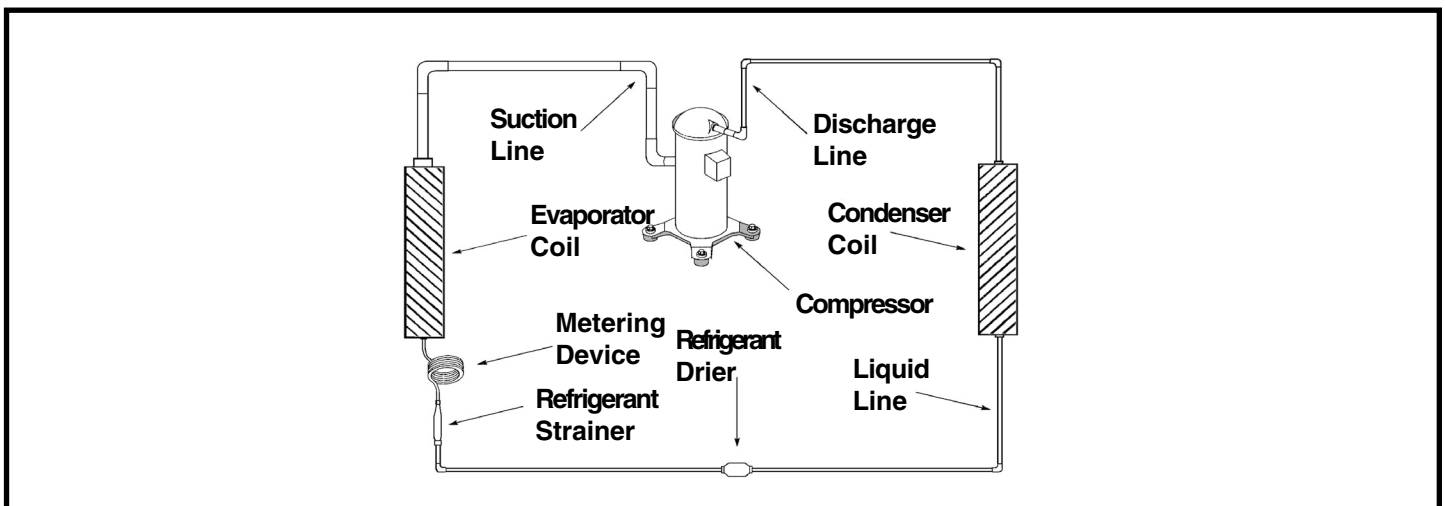

The expansion and absorbing of heat cause the liquid refrigerant to evaporate (i.e. change to a gas). Once the refrigerant has been evaporated (changed to a gas), it is heated even further by the air that continues to flow across the evaporator coil.

The particular system design determines at exactly what point (in the evaporator) the change of state (i.e. liquid to a gas) takes place. In all cases, however, the refrigerant must be totally evaporated (changed) to a gas before leaving the evaporator coil.

The low pressure (suction) created by the compressor causes the refrigerant to leave the evaporator through the suction line as a cool low pressure vapor. The refrigerant then returns to the compressor, where the cycle is repeated.



Electrical Rating Tables

Model	Circuit Rating Breaker or T-D Fuse	Plug Face (NEMA#)	Appearance (Facing Blades)
ALL KQ, SQ and XQ MODELS, KS10J10, KS12J10A, KM14J10, RS10J10, RS12J10A, RM14J10, SS08J10R, SS09J10B, SS10J10R, SS12J10AR, SM14J10R, SC06H10D, YQ06J10A, YS09J10, WS07A10D, WS09A10D, WS12A10D	125V - 15A	5 - 15P	
KS12J30A, KM18J30B, RS16J30, RM19J30, SS12J30B, SS16J30, SM19J30R, WS09A30D, WS12A30D, WS13A30D	250V - 15A	6 - 15P	
KM21J30, KL25J30A, SM21J30B, SL24J30A, SL28J30A*, ES12J33, EK12J33A, ES16J33, YS13J33, WE09A33D, WE12A33D, WE13A33D, WY09A33D, WY12A33E	250V - 20A	6 - 20P	
SL33J30, EM19J34, EK18J34B, EL24J35A, EL33J35, YM18J34A, YL24J35A	250V - 30A	6 - 30P	

* Optional 30 Amp Kit (618-869-00) is recommended in 208 Volt power supply areas that fall below 208 Volts.

For more information, call the Friedrich Service Department.

Due to a program of continuing improvement, specifications are subject to change without notice.

Wire Size Use **ONLY** wiring size recommended for single outlet branch circuit.

Fuse/Circuit Breaker Use **ONLY** type and size fuse or HACR circuit breaker indicated on unit's rating plate. Proper current protection to the unit is the responsibility of the owner.

Grounding Unit **MUST** be grounded from branch circuit through service cord to unit, or through separate ground wire provided on permanently connected units. Be sure that branch circuit or general purpose outlet is grounded.

Receptacle The field supplied outlet must match plug on service cord and be within reach of service cord. Do **NOT** alter the service cord or plug. Do **NOT** use an extension cord. Refer to the table above for proper receptacle and fuse type.

INSTALLATION NOTES:

Supply Cord - All with right angle plug 6' on 115V; 5' on 230/208V. Room air conditioners include accessories for window or thru-wall installation. TwinTemp models include accessories for thru-wall installation. Window mounting requires use of optional accessory kit as listed below:



CAUTION

Electric shock hazard.

Turn off electric power before service or installation.

All electrical connections and wiring **MUST** be installed by a qualified electrician and conform to the National Electrical Code and all local codes which have jurisdiction.

Failure to do so can result in property damage, personal injury and/or death.



FRIEDRICH AIR CONDITIONING CO.

Post Office Box 1540 • San Antonio, Texas 78295-1540
 4200 N. Pan Am Expressway • San Antonio, Texas 78218-5212
 (210) 357-4400 • FAX (210) 357-4480
 Visit us on the Internet at www.friedrich.com



It matters!



The consumer - through the AHAM Room Air Conditioner Certification Program - can be certain that the AHAM Certification Seal accurately states the unit's cooling and heating capacity rating, the amperes and the energy efficiency ratio.

COMPONENTS OPERATION & TESTING

WARNING

DISCONNECT ELECTRICAL POWER TO UNIT BEFORE SERVICING OR TESTING

COMPRESSORS

Compressors are single phase, 115 or 230/208 volt, depending on the model unit. All compressor motors are permanent split capacitor type using only a running capacitor across the start and run terminal.

All compressors are internally spring mounted and externally mounted on rubber isolators.

WINDING TEST

Remove compressor terminal box cover and disconnect wires from terminals. Using an ohmmeter, check continuity across the following: (See Figure 1)

1. Terminal "C" and "S" - no continuity - open winding - replace compressor.
2. Terminal "C" and "R" - no continuity - open winding - replace compressor.
3. Terminal "R" and "S" - no continuity - open winding - replace compressor.

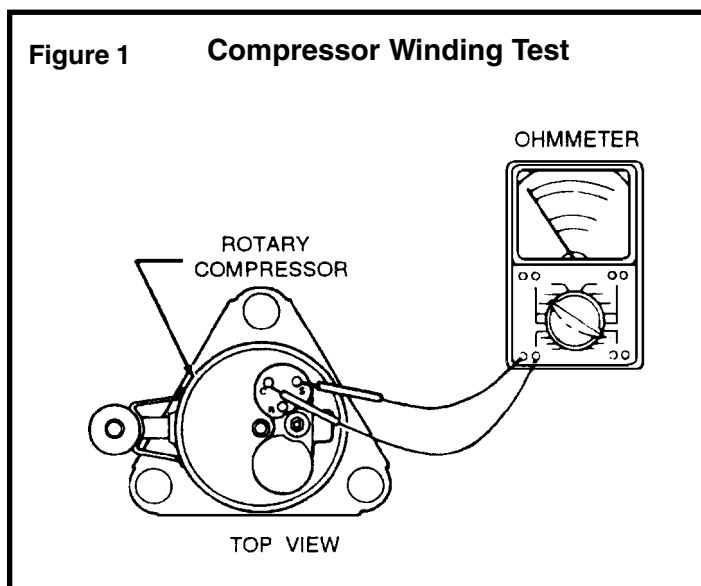

GROUND TEST

Use an ohmmeter set on its highest scale. Touch one lead to the compressor body (clean point of contact as a good connection is a must) and the other probe in turn to each compressor terminal (see Figure 2.) If a reading is obtained, the compressor is grounded and must be replaced.

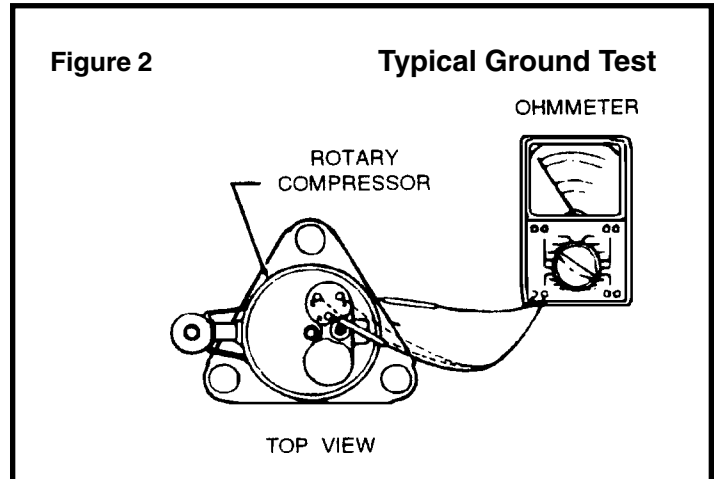

CHECKING COMPRESSOR EFFICIENCY

The reason for compressor inefficiency is normally due to broken or damaged suction and/or discharge valves, reducing the ability of the compressor to pump refrigerant gas.

This condition can be checked as follows:

1. Install a piercing valve on the suction and discharge or liquid process tube.
2. Attach gauges to the high and low sides of the system.
3. Start the system and run a "cooling or heating performance test."

If test shows:

- A. **Below** normal high side pressure.
- B. **Above** normal low side pressure.
- C. **Low** temperature difference across coil.

The compressor valves are faulty - replace the compressor.

THERMAL OVERLOAD (External)

Some compressors are equipped with an external overload which is located in the compressor terminal box adjacent to the compressor body (See Figure 3.)

The overload is wired in series with the common motor terminal. The overload senses both major amperage and compressor temperature. High motor temperature or amperage heats the disc causing it to open and break the circuit to the common motor terminal.

CHECKING THE INTERNAL OVERLOAD
(See Figure 4)

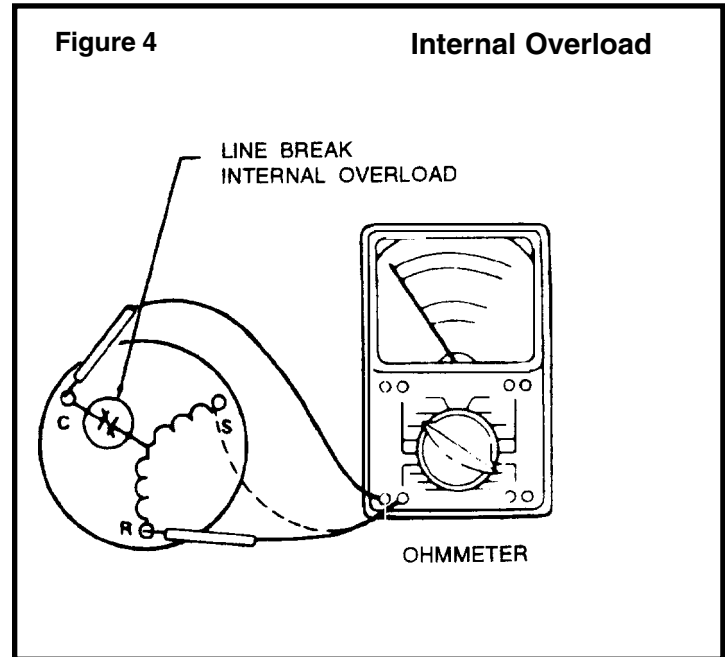
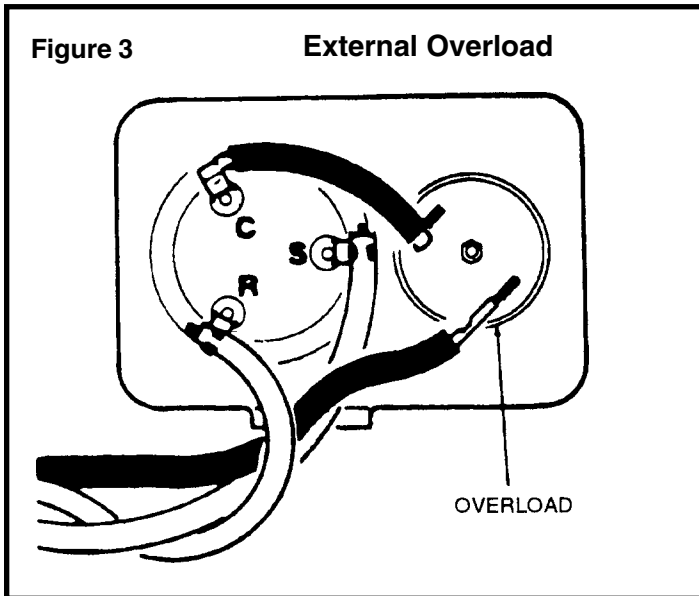

Heat generated within the compressor shell is usually due to:

1. High amperage.
2. Low refrigerant charge.
3. Frequent recycling.
4. Dirty condenser.

1. With no power to unit, remove the leads from the compressor terminals.
2. Using an ohmmeter, test continuity between terminals C-S and C-R. If not continuous, the compressor overload is open and the compressor must be replaced.

TERMINAL OVERLOAD - TEST
(Compressor - External Type)

1. Remove overload.
2. Allow time for overload to reset before attempting to test.
3. Apply ohmmeter probes to terminals on overload wires. There should be continuity through the overload.

FAN MOTOR

A single phase permanent split capacitor motor is used to drive the evaporator blower and condenser fan. A self-resetting overload is located inside the motor to protect against high temperature and high amperage conditions. (See Figure 5)

TERMINAL OVERLOAD (Internal)

Some model compressors are equipped with an internal overload. The overload is embedded in the motor windings to sense the winding temperature and/or current draw. The overload is connected in series with the common motor terminal.

Should the internal temperature and/or current draw become excessive, the contacts in the overload will open, turning off the compressor. The overload will automatically reset, but may require several hours before the heat is dissipated.

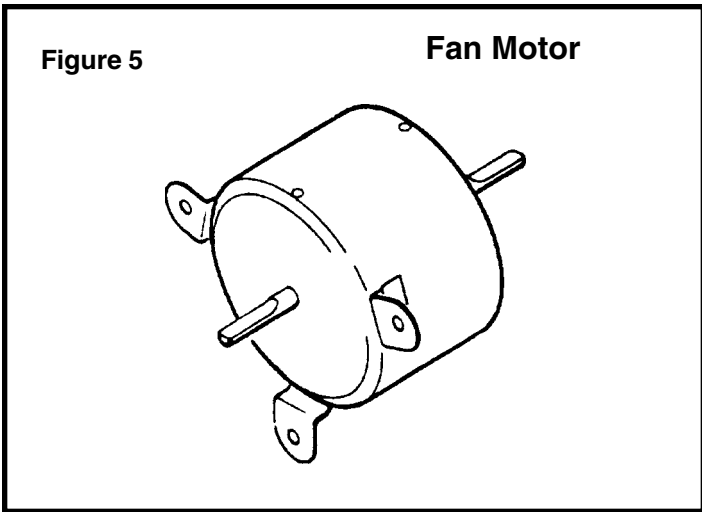

FAN MOTOR - TEST

1. Determine that capacitor is serviceable.
2. Disconnect fan motor wires from fan speed switch or system switch.
3. Apply "live" test cord probes on black wire and common terminal of capacitor. Motor should run at high speed.
4. Apply "live" test cord probes on red wire and common terminal of capacitor. Motor should run at low speed.
5. Apply "live" test cord probes on each of the remaining wires from the speed switch or system switch to test intermediate speeds. If the control is in the "MoneySaver" mode and the thermostat calls for cooling, the fan will start - then stop after approximately 2 minutes; then the fan and compressor will start together approximately 2 minutes later.

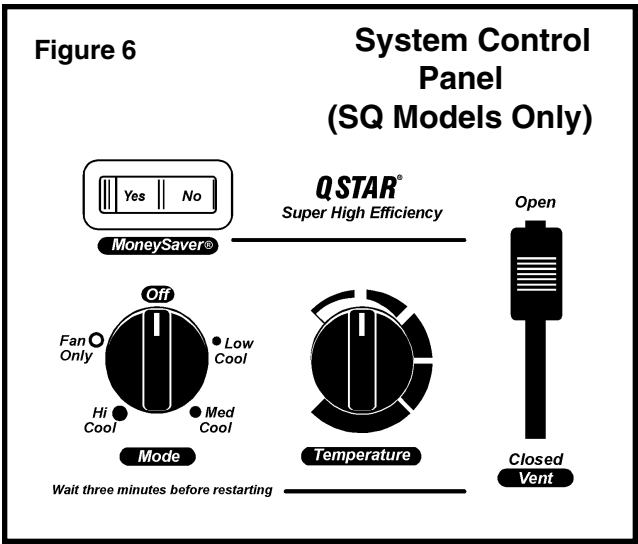
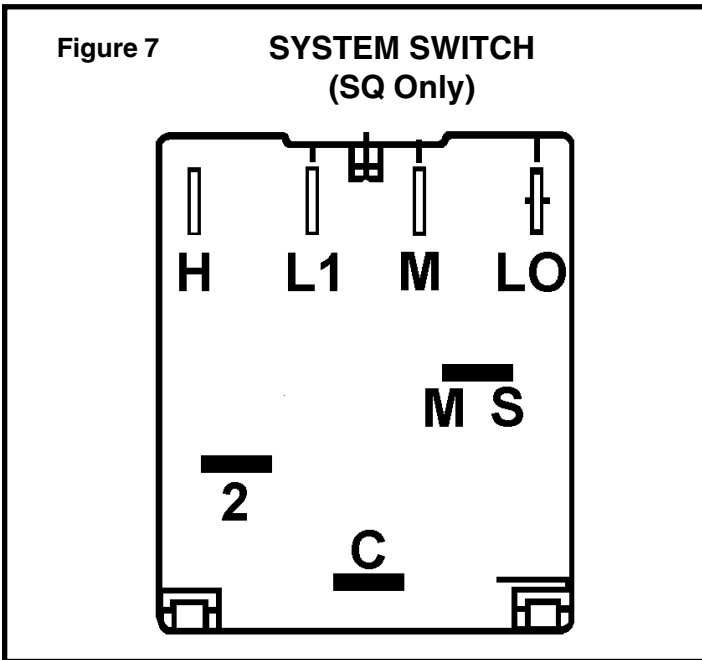

SYSTEM CONTROL SWITCH (SQ Models)

(See Figure 6)

A five-position control switch is used to regulate the operation of the fan motor and compressor. The compressor can be operated with the fan operating at low, medium or high speed. The fan motor can also be operated independently on medium speed. See switch section as indicated on the decorative control panel.

SYSTEM CONTROL SWITCH - TEST (See Figure 7)

Disconnect the leads from the control switch. There must be continuity as follows:

1. "Off" Position - no continuity between terminals.
2. "Lo Cool" Position - between terminals "L1" and "C", "Lo" and "MS".
3. "Med Cool" Position - between terminals "L1" and "C", "M" and "MS".
4. "Hi Cool" Position - between terminals "L1" and "C", "H" and "MS".
5. "Fan Only" Position - between terminals "L1" and "2".

RESISTOR
(Heat Anticipator) (SQ Only)

Failure of the resistor will cause prolonged "off" and "on" cycles of the unit. When replacing a resistor, be sure and use the exact replacement. Resistor rating 115 Volts 12500 ohm, 1.05 watts.

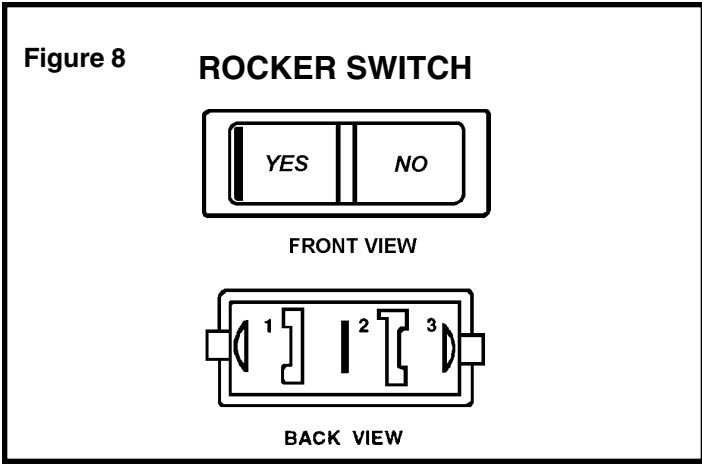

MONEYSAVER® SWITCH
(Rocker Switch) (See Figure 8)

This rocker switch can be depressed to either **YES** or **NO**. In the **YES** position you will get the most economical operation. Both the fan and the compressor will cycle on and off together, maintaining the selected temperature at a more constant level and reducing the humidity more efficiently. This control will only operate when the unit is in a cooling mode. In the **NO** position, the fan will run constantly as long as the unit is in the cooling mode. Disconnect leads from switch. Depress switch to function being tested.

1. When **YES** is depressed, there should be continuity between terminals "1" and "2."
2. When **NO** is depressed, there should be continuity between terminals "2" and "3."

SYSTEM CONTROL SWITCH
("KQ" Models Only) (See Figure 9)

The KQ Model unit uses a five position control switch to regulate the operation of the unit. Function of each position (clockwise rotation) is as follows:

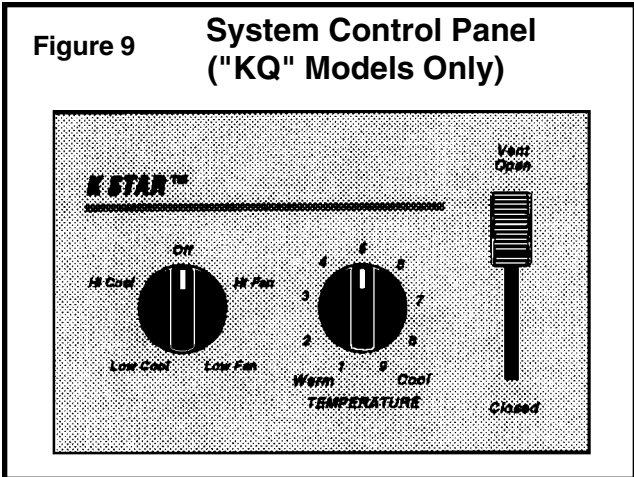

1. "Off" - Turns everything off.
2. "Hi Fan" - Maximum circulation of filtered room air (no cooling.)
3. "Low Fan" - Fan runs slower for less circulation of filtered room air.
4. "Low Cool" - Fan runs slowly for quiet operation when maximum cooling is not needed.
5. "Hi Cool" - Highest fan speed for maximum cooling.

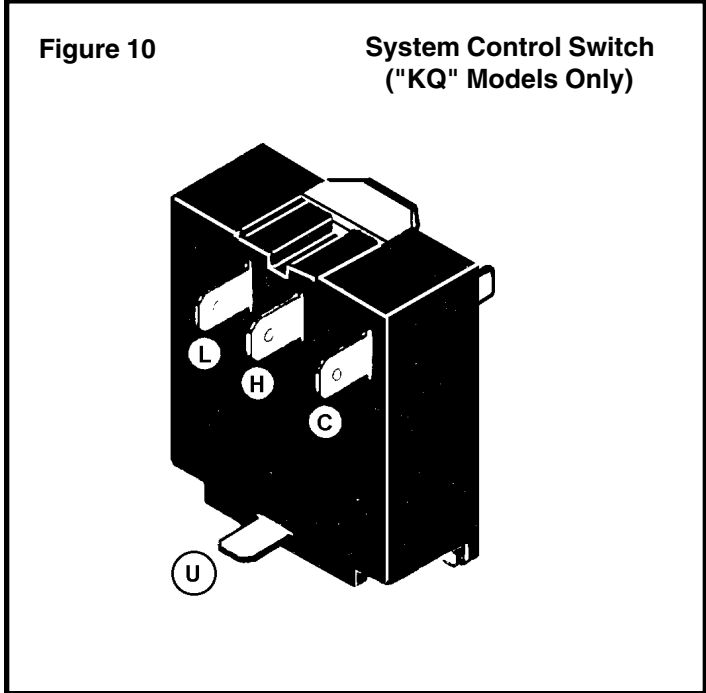

SYSTEM CONTROL SWITCH - TEST
(See Figure 19)

Turn knob to phase of switch to be tested. There must be continuity as follows:

1. "Hi Fan" Position - between terminals "L1" and "H".
2. "Low Fan" Position - between terminals "L1" and "L".
3. "Low Cool" Position - between terminals "L1" and "L" and "C".
4. "Hi Cool" Position - between terminals "L1" and "H" and "C".

SYSTEM CONTROL SWITCH

("YQ" Model Only) (See Figure 11)

The YQ Model unit uses a six position control switch to regulate the operation of the unit (see Figure 9). Function of each position (Clockwise rotation) is as follows:

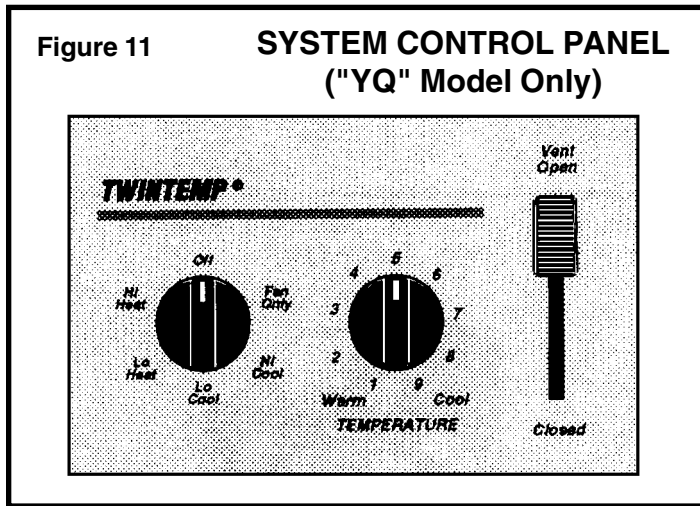

1. "Off" - Turns everything off.
2. "Fan Only" - To circulate filtered room air, but no cooling or heating.
3. "Hi Cool" - Fan runs continuously, compressor goes on and off to maintain the selected room temperature.
4. "Lo Cool" - Fan runs continuously, compressor goes on and off to maintain the selected room temperature.
5. "Lo Heat" - Fan Runs continuously, heating turns on and off to maintain the selected room temperature.
6. "Hi Heat" - Fan Runs continuously, heating turns on and off to maintain the selected room temperature.

SYSTEM CONTROL SWITCH - TEST (See Figure 12)

Turn knob to phase of switch to be tested. There must be continuity as follows:

1. "Fan Only" Position - between terminals "C" and "1".
2. "Hi Cool" Position - between terminals "C" and "1", "C" and "3".
3. "Lo Cool" Position - between terminals "C" and "2", and "C" and "3".
4. "Lo Heat" Position - between terminals "C" and "2", and "C" and "4".

Figure 12

System Control Switch

("YQ" Models Only)

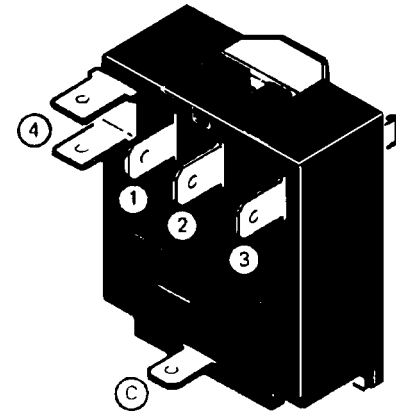

5. "Hi Heat" Position - between terminals "C" and "1", and "C" and "4".

ROTARY (SYSTEM) SWITCH ("SC" Model) (See Figure 13)

A rotary four position switch is used to turn on the unit and select the operation desired. Switch selection is as follows:

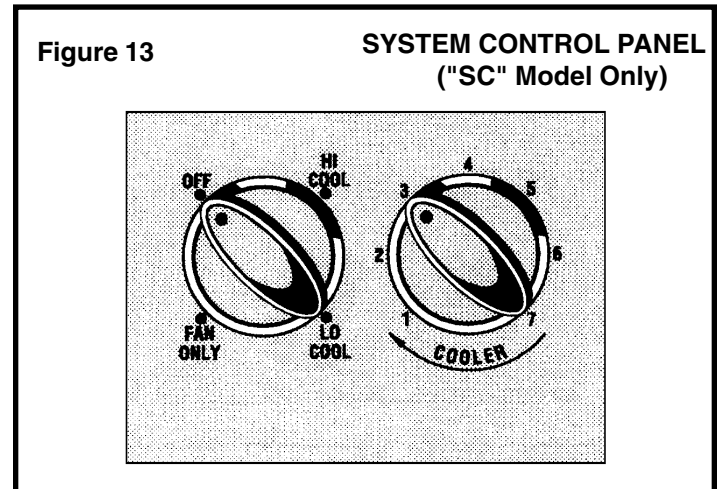

1. "Hi Cool" Turns on the compressor and fan at high speed
2. "Lo Cool" Turns on the compressor and fan at low speed.
3. "Fan Only" Turns on the fan at high speed.
4. "Off" Turns everything off.

The switching arrangement of the control is as follows: (See Figure 14.)

1. "Off" All contacts open.
2. "Hi Fan" Contacts closed between terminals "L1" and "1".

- "Hi Cool" Contacts closed between terminals "L1" to "1" and "L1" and "C".
- "Lo-Cool" Contacts are closed between terminals "L1" to "2" and "L1" to "C".

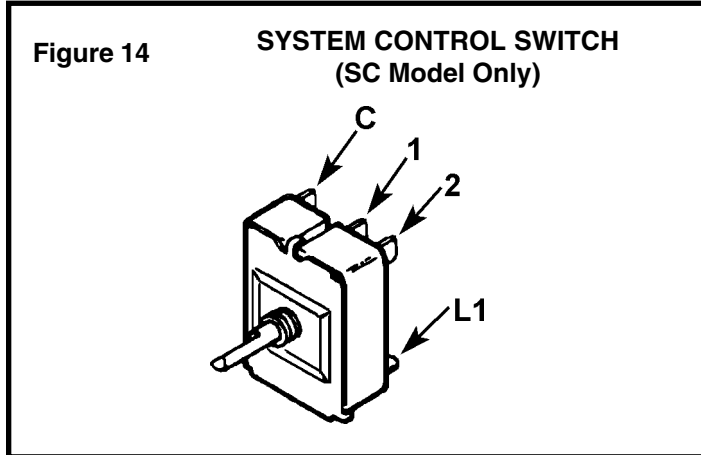

- Disconnect leads from control switch.
- Check continuity between all switch positions shown in Figure 14.

SYSTEM CONTROL SWITCH
("WS" Models) (See Figure 15)

A five position control switch is used to regulate the operation of the fan motor and compressor. The compressor can be operated with the fan operating at low, medium or high speed. The fan motor can also be operated independently on medium speed. See switch section as indicated on decorative control panel

SYSTEM CONTROL SWITCH - TEST

Disconnect leads from control switch (See Figure 16.)
There must be continuity as follows:

- "Off" Position - no continuity between terminals.
- "Lo Cool" Position - between terminals "L1" and "C", "LO" and "MS."
- "Med Cool" Position - between terminals "L1" and "C", "M" and "MS".
- "Hi Cool" Position - between terminals "L1" and C", "H" and "MS."
- "Fan Only" Position - between terminals "L1" and "2."

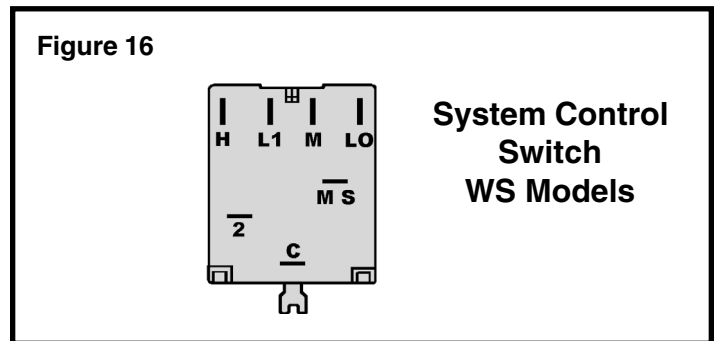
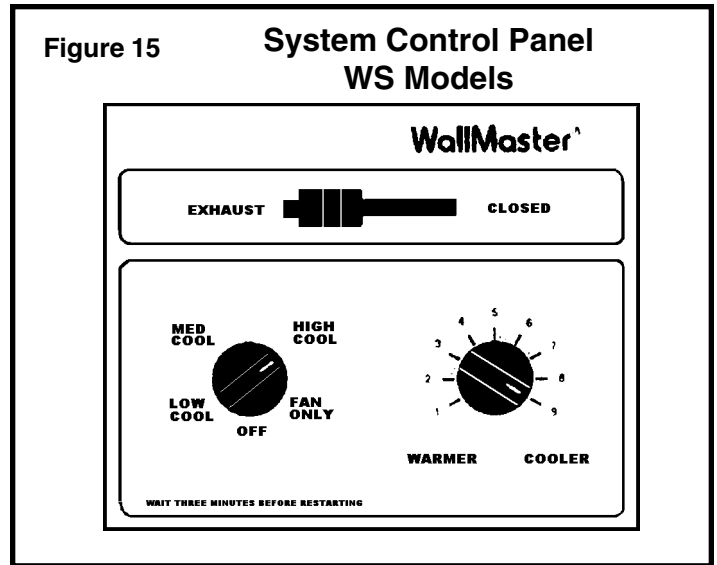

SYSTEM CONTROL SWITCH
("WE" & "WY" Models) (See Figure 17)

An eight position switch is used to regulate the operation of the fan motor, compressor and electric heater. The unit can be operated in cooling or heating mode with the compressor or electric heater on and the fan motor operating on low, medium or high speed.

The fan motor can also be operated independently on medium speed. See switch section as indicated on decorative control panel.

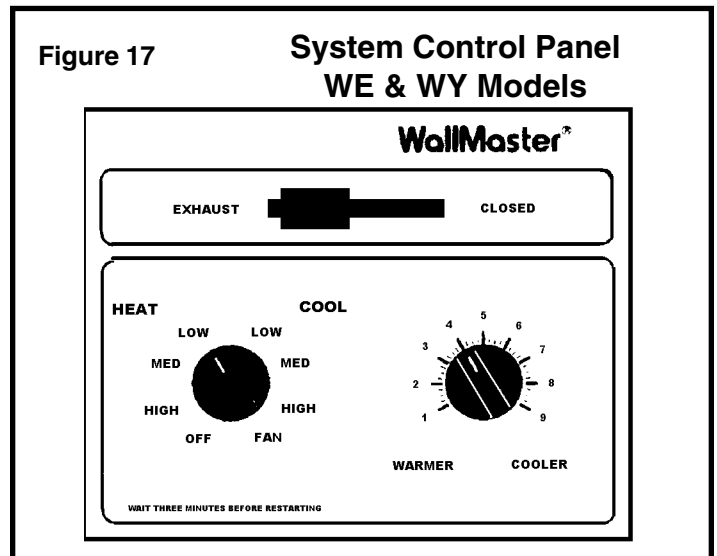

SYSTEM CONTROL SWITCH - TEST (See Figure 18)

Disconnect leads from control switch. Turn control to position being tested. There must be continuity as follows:

1. "Off" Position-no continuity between terminals.
2. "Lo Cool" Position-between terminals "C" and "3", "C2" and "2", "LO" and "M/S", "AR" and "5".
3. "Med Cool" Position-between terminals "C" and "3", "C2" and "2", "M" and "M/S", "AR" and "5".
4. "Hi Cool" Position-between terminals "C" and "3", "C2" and "2", "H" and "M/S", "AR" and "5".
5. "Hi Heat" Position-between terminals "C" and "1", "C2" and "4", "H" and "M/S", "AR" and "5".
6. "Med Heat" Position-between terminals "C" and "1", "C2" and "4", "M" and "M/S", "AR" and "5".
7. "Lo Cool" Position-between terminals "C" and "1", "C2" and "4", "LO" and "M/S", "AR" and "5".
8. "Fan Only" Position-between terminals "L1" and "M".

2. "Lo Cool" Position - between terminals "L1" and "C," "LO" and "MS."
3. "Med Cool" Position - between terminals "L1" and "C," "M" and "MS."
4. "Hi Cool" Position - between terminals "L1" and "C," "H" and "MS."
5. "Fan Only" Position - between terminals "L1" and "2."

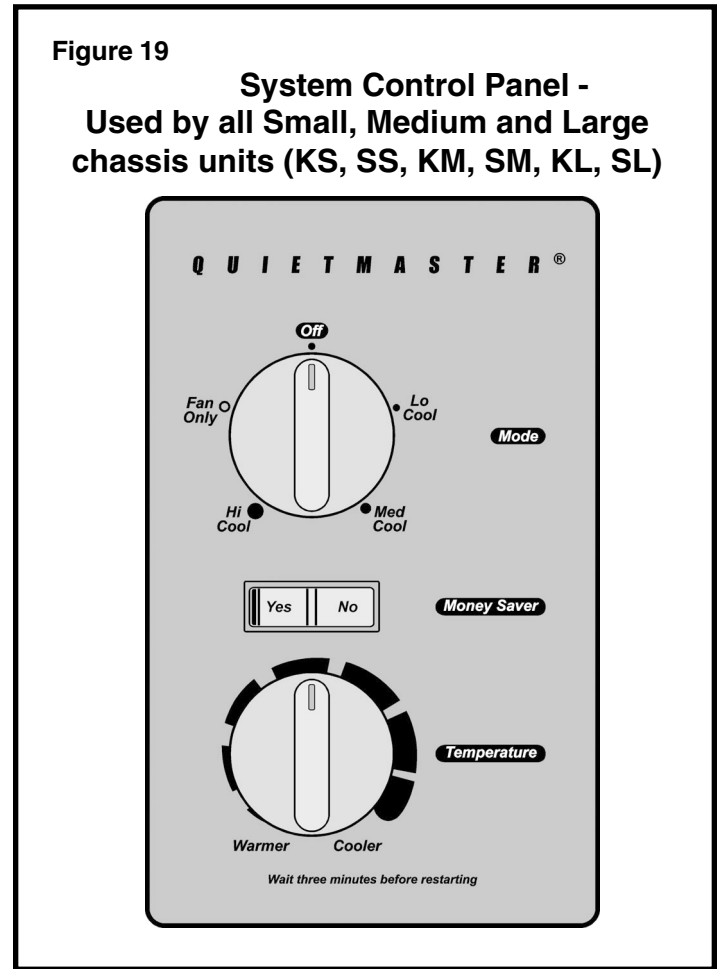
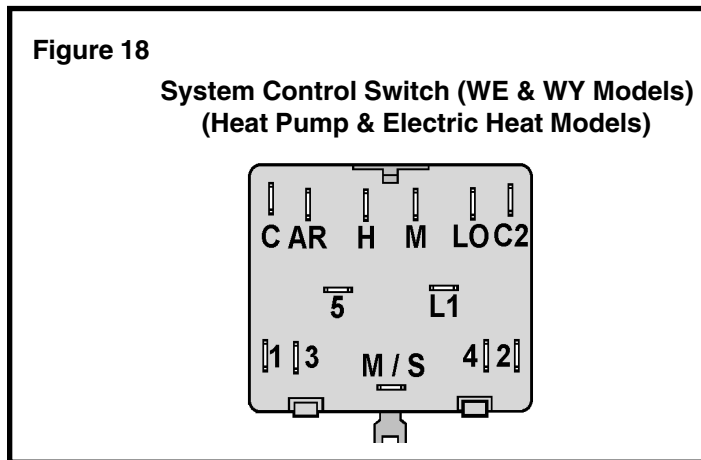

SYSTEM CONTROL SWITCH KS, SS, KM, SM, KL, SL Models (See Figure 19)

A five position control switch is used to regulate the operation of the fan motor and compressor. The compressor can be operated with the fan operating at low, medium or high speed. The fan motor can also be operated independently on medium speed. See switch section as indicated on decorative control panel.

SYSTEM CONTROL SWITCH - TEST (See Figure 20)

Disconnect leads from control switch. There must be continuity as follows:

1. "Off" Position - no continuity between terminals.

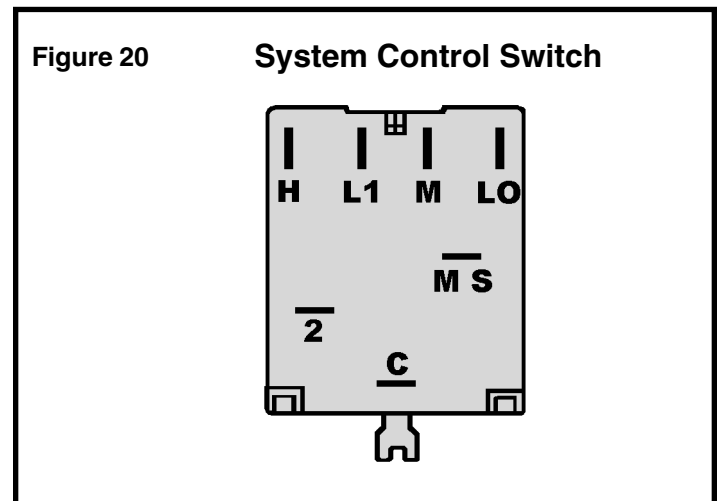

SYSTEM CONTROL SWITCH (See Figure 21)

A six-position control switch is used to regulate the operation of the fan motor and compressor. The compressor can be operated with the fan operating at low, medium or high speed. The fan motor can also be operated independently on medium speed. See switch section as indicated on decorative control panel.

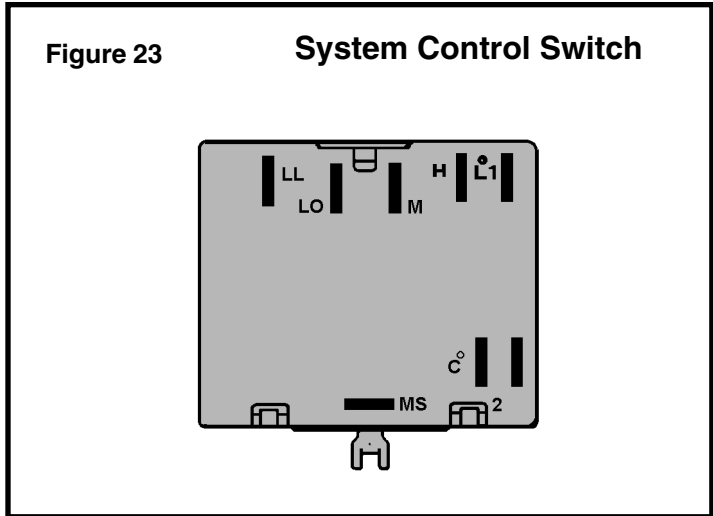
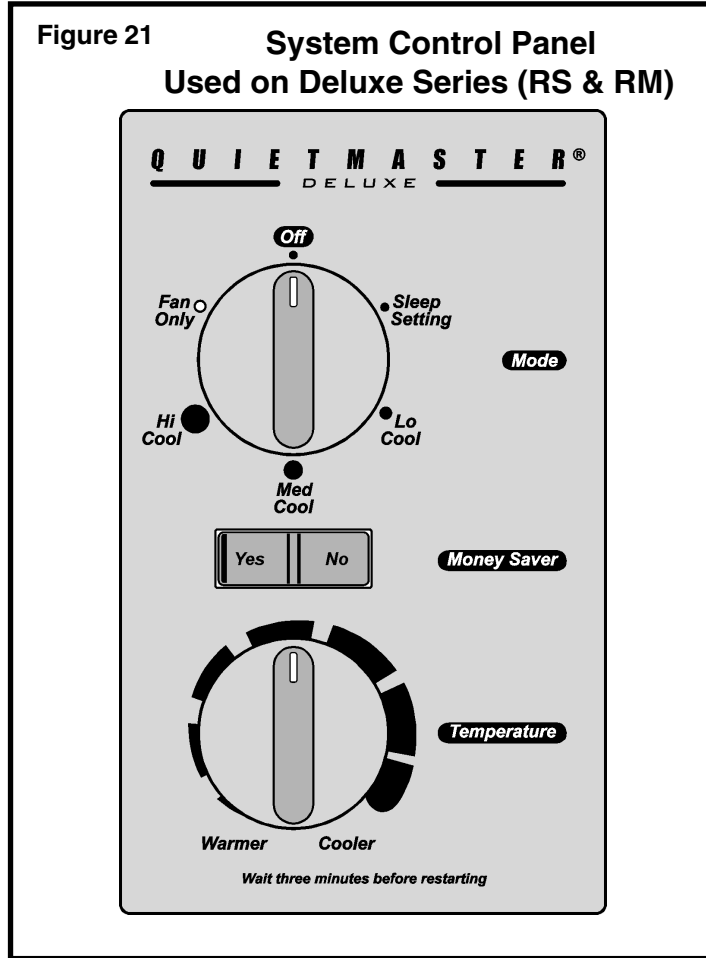

SYSTEM CONTROL SWITCH (See Figure 23)
(Heat Pump & Electric Heat Models)

An eight position control switch is used to regulate the operation of the fan motor and compressor. The compressor can be operated with the fan operating at low, medium or high speed in the cooling or heating mode. The fan motor can also be operated independently on medium speed. See switch section as indicated on decorative control panel.

1. "Off" Position - everything is off.
2. "Lo Cool" Position - fan operates on low speed, compressor is on.
3. "Med Cool" Position - fan operates on medium speed, compressor is on.
4. "Hi Cool" Position - fan operates on high speed, compressor is on.
5. "Hi Heat" Position - fan operates on high speed, compressor or electric heater is on.
6. "Med Heat" Position - fan operates on medium speed, compressor or electric heater is on.

SYSTEM CONTROL SWITCH - TEST

Disconnect leads from control switch (See Figure 22.) There must be continuity as follows:

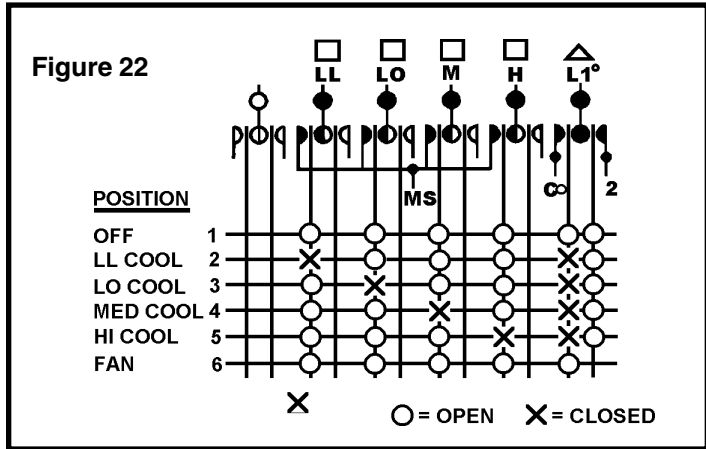

**SYSTEM CONTROL SWITCH (See Figure 24)
(Heat Pump & Electric Heat Models)**

An eight position control switch is used to regulate the operation of the fan motor and compressor. The compressor can be operated with the fan operating at low, medium or high speed in the cooling or heating mode. The fan motor can also be operated independently on medium speed. See switch section as indicated on decorative control panel.

1. "Off" Position - everything is off.
2. "Lo Cool" Position - fan operates on low speed, compressor is on.
3. "Med Cool" Position - fan operates on medium speed, compressor is on.
4. "Hi Cool" Position - fan operates on high speed, compressor is on.
5. "Hi Heat" Position - fan operates on high speed, compressor or electric heater is on.
6. "Med Heat" Position - fan operates on medium speed, compressor or electric heater is on.

7. "Lo Heat" Position - fan operates on low speed, compressor or electric heater is on.
8. "Fan Only" Position - operates on medium speed.

NOTE: Heat pump models with electric heat - in the heat position, heating element only will be energized when outdoor temperature is below the operating range of the heat pump.

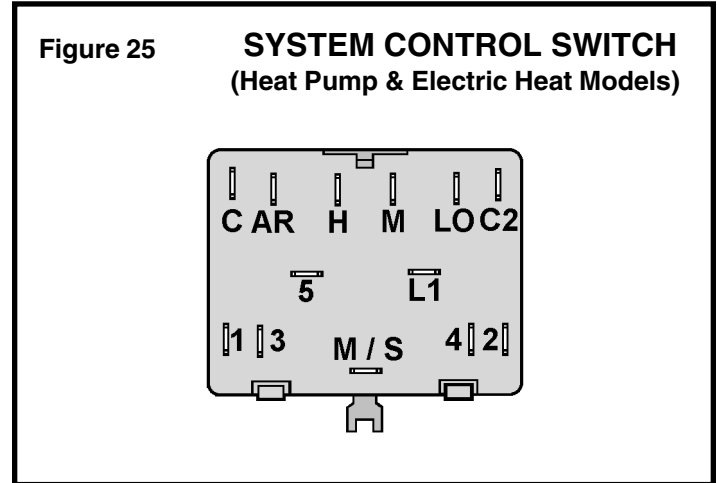

SYSTEM CONTROL SWITCH - TEST (See Figure 25)

Disconnect leads from control switch. Turn control to position being tested. There must be continuity as follows:

1. "Off" Position - no continuity between terminals.
2. "Lo Cool" Position - between terminals "C" and "3", "C2" and "2", "LO" and "M/S", "AR" and "5".
3. "Med Cool" Position - between terminals "C" and "3", "C2" and "2", "M" and "M/S", "AR" and "5".
4. "Hi Cool" Position - between terminals "C" and "3", "C2" and "2", "H" and "M/S", "AR" and "5".
5. "Hi Heat" Position - between terminals "C" and "1", "C2" and "4", "H" and "M/S", "AR" and "5".
6. "Med Heat" Position - between terminals "C" and "1", "C2" and "4", "M" and "M/S", "AR" and "5".
7. "Lo Cool" Position - between terminals "C" and "1", "C2" and "4", "LO" and "M/S", "AR" and "5".
8. "Fan Only" Position - between terminals "L1" and "M".

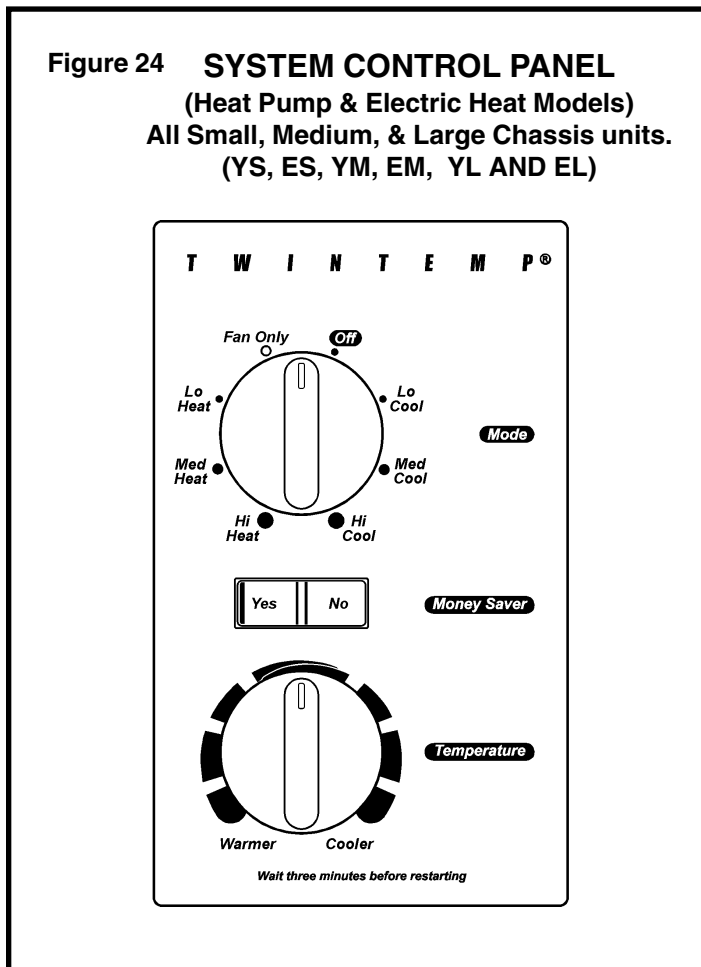

Smart Center Electronic Control Center:

(See Figure 26)

FILTER ALERT light will come on after 250 hours of use. Touch **FILTER ALERT** to reset.

TO SET MODE OF OPERATION

When unit is first turned on, it will be in the COOL mode (light on), with constant fan.

Touch **MONEYSAVER** (light on) to activate the MoneySaver feature. (MoneySaver is a feature that cycles the fan with the compressor so that the fan does not run all the time. This saves energy and improves dehumidification.) If customer prefers a constant fan for more air movement, touch **MONEYSAVER** again and unit will return to constant fan.

Touch **FAN ONLY** (light on) and only the fan will run. This feature may be used in conjunction with the **FRESH AIR/ EXHAUST** lever to bring outside air into a room, or to exhaust stale air.

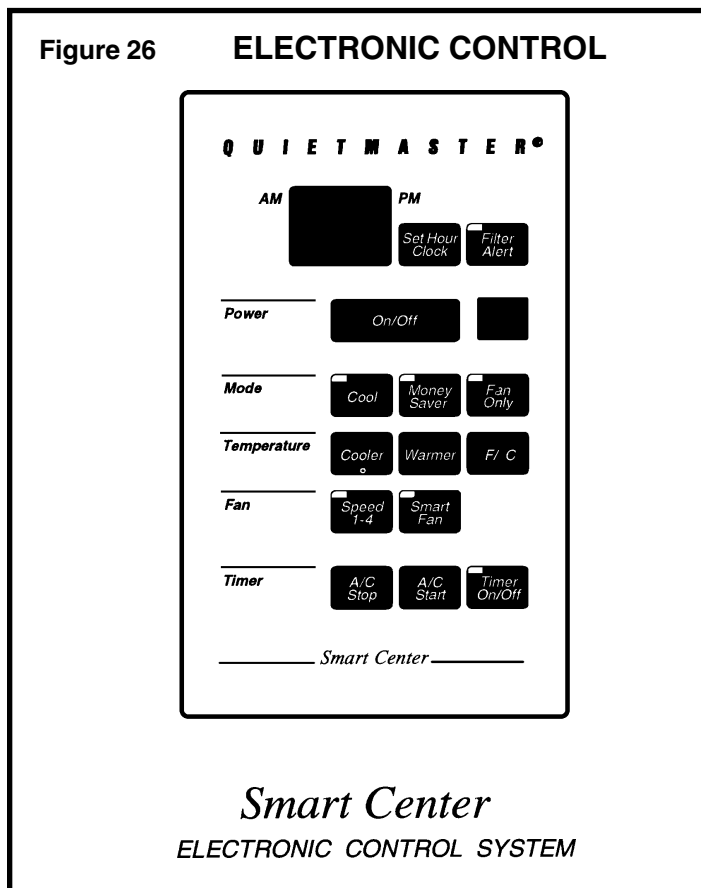

TO ADJUST TEMPERATURE

COOLER - Touch **COOLER** to see setting, touch again to change.

WARMER - Touch **WARMER** to see setting, touch again to change.

Touch **°F/°C** to show desired temperature in Fahrenheit or Celsius.

TO ADJUST FAN SPEED

Touch **SPEED** to see current setting. Touch again to change speed. F1 is lowest setting (sleep setting), F2 is LOW, F3 is MED, and F4 is HIGH.

TO ACTIVATE SMART FAN

Touch **SMART FAN** (light on). Smart Fan will adjust the fan speed automatically to maintain the desired comfort level. For example, if the outside doors in the home are open for an extended period of time, or more people enter a room, Smart Fan may adjust to a higher fan speed to compensate for the increased heat load. This keeps from having to adjust the fan speed on your own, or from having to change the desired temperature you have selected. Smart Fan will also run to test temperature if the off cycle is long.

TO SET HOUR CLOCK

Touch **SET HOUR CLOCK** to see setting. To change, touch and hold until hour closest to the actual time appears in the display. **MAKE SURE A.M. AND P.M. ARE SET PROPERLY.** (Minutes will NOT show on display.)

TO SET THE TIMER

NOTE: SET HOUR CLOCK before attempting to set timer functions.

The TIMER ON/OFF times can be set a **minimum** of one hour apart and a **maximum** of twenty-three hours apart.

STOP TIME - Touch **A/C STOP** and hold until the hour the unit needs to shut off appears in the display (A.M. or P.M.)

START TIME - Touch **A/C START** and hold until the hour the unit needs to come on appears in the display (A.M. or P.M.)

Touch **TIMER ON** (light on) to activate the timer function. Touch **TIMER OFF** (light off) to cancel the timer function desired. Once the on and off times have been selected, they will remain in memory, and cycle daily until changed, or until the unit is subject to a power interruption.

TESTING THE ELECTRONIC CONTROL

2001 XQ BOARDS & QME BOARDS

Checking Room Temperature:

1. Check the room temperature at the electronic control pad by pressing the "**FAN SPEED**" button and the temperature "**UP**" button at the same time on **XQ models**.
2. Check the room temperature at the electronic control pad by pressing at the same time the "**FAN SPEED**" button and the "**WARMER**" button on **QME models**.

The indoor temperature will display for 10 seconds. Indoor temperature can be viewed in all modes, including the TEST mode. The display can be changed back to SET temperature by pressing any key, except the ON/OFF button, or after 10 seconds has elapsed.

Activating Test Mode: Activate test mode by pressing at the same time the "**MODE**" button and the temperature "**DOWN**" button on **XQ models**. LEDs for Hour, Start, and Stop will blink 1 bps while Test Mode is active.

Activate test mode by pressing at the same time the "**MONEY SAVER**" button and the "**FILTER ALERT**" button on **QME models**. LED for the Filter Alert will blink 1 bps while Test Mode is active.

Test Mode has duration of 90 minutes. Test Mode can be activated under any conditions, including Off. Test Mode is cancelled by pressing the On/Off button, unplugging the unit, or when the 90 minutes is timed out. All settings revert to the factory default settings of Cool, 75 degrees F, Timer and Set Hour features are nonfunctional.

Test Mode overrides the three-minute lockout, all delays for compressor and fan motor start / speed change, and no delay when switching modes.

Test Mode default settings are ON, Money Saver, 60 degrees F, and High fan speed.

Activating Error Code Mode: (Submode of Test Mode) Unit has to be in Test Mode to enter Error Code Mode

1. Activate Error Code Mode by pressing the "**TIMER ON/OFF**" button on XQ models. LED for the "**TIMER ON/OFF**" will flash 1 bps while Error Code Mode is active. Pressing the "**TEMP/HR +**" button will display 00. Consecutive presses will scroll through all error codes logged. Press the "**TEMP/HR -**" button to see the reverse order of all error codes logged. When the end of logged error codes is reached the temperature set point will appear.

Activate Error Code Mode by pressing at the same time the "**A/C START**" button and the "**ON/OFF**" button on QME models. LED for the "**TIMER ON/OFF**" will flash 1 bps while Error Code Mode is active. Pressing the "**WARMER**" button will display 00. Consecutive presses will scroll through all error codes logged. Press the "**COOLER**" button to see the reverse order of all error codes logged. When the end of logged error codes is reached the temperature set point will appear.

IMPORTANT

Error Codes are cleared from the log by exiting from Error Code Mode. To exit on XQ models, press Timer On/Off button. To exit QME models, press A/C Start and On/Off buttons. Or unplug unit to exit Error Code Mode. Plug unit in after 5 seconds to resume normal operation of unit.

TESTING THE ELECTRONIC CONTROL

ERROR CODE LISTINGS

E1 SHORT CYCLE SITUATION: Defined as (compressor powered on before the three minute time delay ten times in one hour. Investigate and correct short cycling problem.

E2 KEYBOARD STUCK ERROR: If key button(s) are pressed continuously for twenty seconds or more. If MODE key is stuck, unit will default to cool. Exit Error Code Mode to see if error "E2" is no longer displayed and unit is functioning. Replace board if "E2" still displays after exiting Error Code Mode.

E3 FROST PROBE OPEN: Normal operation is allowed. Ohm frost probe. Replace probe if ohm value not read. If ohm value present replace board.

E4 FROST PROBE SHORT: Normal operation allowed. Replace probe.

E5 INDOOR PROBE OPEN: Control assumes indoor ambient temperature is 90 degree F and unit will operate. Ohm indoor probe. Replace probe if ohm value not read.

E6 INDOOR PROBE SHORT: Control assumes ambient temperature is 90 degree F and unit will operate. Replace probe.

NOTE: All Error Code displays for Frost & Indoor Probe will allow unit to operate. Unit may or will ice up if faulty components not replaced.

FROST PROBE SENSOR: disables compressor at 35 degrees F.

INDOOR PROBE SENSOR: Control range is 60 degrees F to 90 degrees F +/- 2 degrees F.

Indoor temperature will be displayed by pressing:

(QME Units) The **Fan Speed** button and the **Warmer** button.

(XQ Units) The **Fan Speed** button and the **Temp Up** button.

The indoor temperature will be displayed for 10 seconds. The display will change back to the Set Point temperature by pressing any key button except for the On/Off button. The indoor temperature can be viewed in all modes, including test mode.

Filter Alert: The **Filter Alert** indicator turns on after the fan motor has been operating for 250 hours. The **Filter Alert** indicator is reset by pressing the **Filter Alert** button one time only. Power failures will not reset the 250 hour timer. All time elapsed is stored in memory and resumes counting after power is restored.

Keep Alive: The electronic control has a memory to retain all functions and status as set up by the user in the event of a power failure. Once power is restored to the unit there is a two second delay before the fan comes on and approximately three minutes delay before the compressor is activated,

providing that the mode was set for cooling and the set point temperature has not been met in the room.

THERMOSTAT ("SQ & KQ" Models) - See Figure 27.

Thermostat is used to cycle the compressor on and off at the comfort level desired. The thermostat has a range from $60^{\circ} \pm 2^{\circ}\text{F}$ to $90^{\circ} \pm 4^{\circ}\text{F}$, with a differential of 5°F . Turning the knob clockwise lowers the indoor room temperature setting, while turning the knob counterclockwise raises the indoor temperature.

TEST:

Remove wires, turn thermostat to its coldest position. Check for continuity between the two terminals. Turn thermostat to warmest position, check continuity to see if contacts open. NOTE: Temperature must be in range listed to check thermostat.

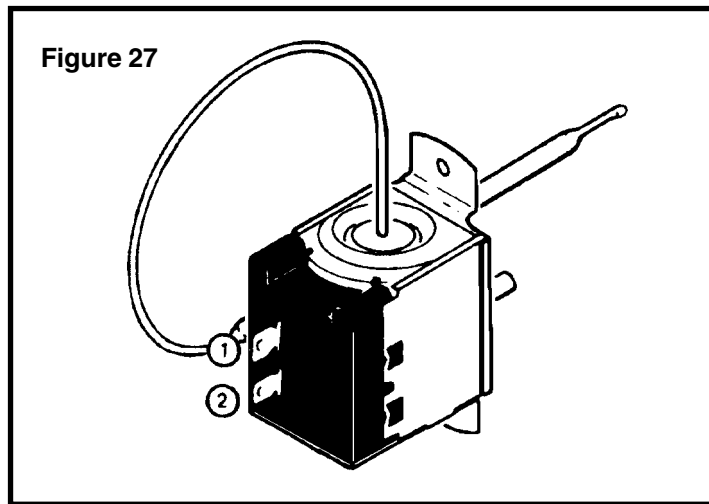

THERMOSTAT ("YQ" Model Only)

See Figure 28.

This thermostat is single pole-double throw, cross ambient with a range of 60° to 92°F and a differential of $\pm 2^{\circ}\text{F}$. Terminal "2" is common.

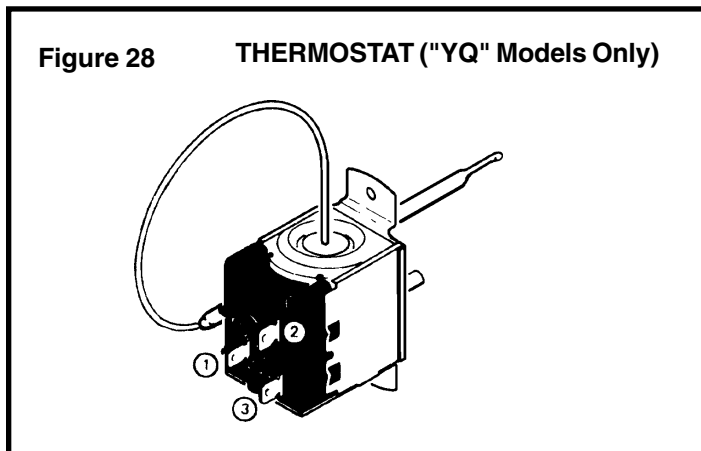

TEST:

1. Remove leads from thermostat.
 2. Turn thermostat knob clockwise to its coldest position.
 3. Test for continuity between the two terminals. Contacts should be closed.
 4. Turn thermostat knob counterclockwise to its warmest position.
 5. Test for continuity - contacts should be open.
- NOTE: The thermostat must be within the temperature range listed to open and close.

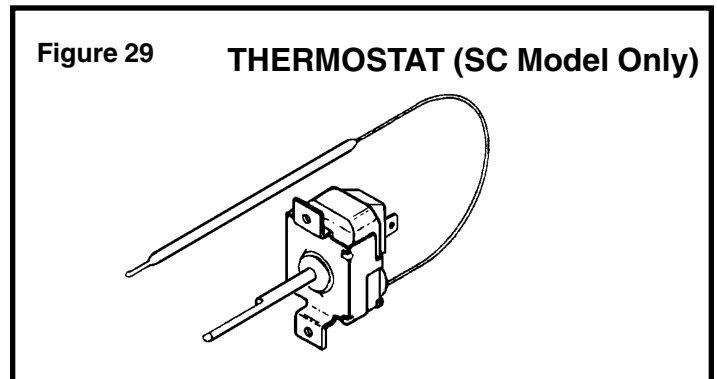

To maintain the comfort level desired, a cross ambient type thermostat is used. The thermostat has a range from $65^{\circ} \pm 2^{\circ}\text{F}$ to $87^{\circ} \pm 3^{\circ}\text{F}$. The thermostat bulb is positioned in front of the evaporator coil to sense the return air temperature. Thermostat malfunction or erratic operation is covered in the troubleshooting section of this manual.

TEST:

1. Remove leads from thermostat.
 2. Turn thermostat knob clockwise to its coldest position.
 3. Test for continuity between the two terminals. Contacts should be closed.
 4. Turn thermostat knob counterclockwise to its warmest position.
 5. Test for continuity - contacts should be open.
- NOTE: The thermostat must be within the temperature range listed to open and close.

THERMOSTAT - Models ES, YS, EM, YM, EL, YL
 (See Figure 29)

A cross ambient thermostat is used on all heat pump and electric heat units. In addition to cycling the unit in a heating or cooling operation, the thermostat will terminate the cooling cycle in the event ice forms on the evaporator coil, in this case the thermostat functions as a de-ice control. A resistor (anticipator) is positioned within a plastic block to supply a small amount of heat to the bulb area to prevent long "off cycles" in the "Cool-Fan Auto" (MoneySaver) position (see Figure 8.) A current feedback through the fan motor windings during "off cycle" completes the circuit to the resistor.

In the heating cycle, the heat anticipator is energized to supply a small amount of heat during the "on" cycle. This will open the contacts in the thermostat prematurely to maintain a closer differential between the "cut in" and "cut out" temperature. The heat anticipator is energized in the heating mode regardless of whether fan is placed in the automatic (MoneySaver) or constant run position.

RANGE: Cooling Model Thermostat
 60°F (±2°) to 92°F (±4°),

TEST:

Cooling/Heating Models: Remove wires from thermostat and check continuity between terminal "2" (common) and "3" for cooling. Check between terminals "2" (common) and "1" for heating. Also check that contacts in thermostat open after placing in either position. NOTE: Temperature must be within range listed to check thermostat. Refer to the troubleshooting section in this manual for additional information on thermostat testing.

THERMOSTAT ADJUSTMENT

No attempt should be made to adjust thermostat. Due to the sensitivity of the internal mechanism and the sophisticated equipment required to check the calibration, it is suggested that the thermostat be replaced rather than calibrated. Thermostat bulb must be straight to insure proper performance.

THERMOSTAT BULB LOCATION

The position of the bulb is important in order for the thermostat to function properly. The bulb of the thermostat should be located approximately 45° to a maximum of 60° from horizontal. Also, do not allow the thermostat bulb to touch the evaporator coil. (See Figures 30 and 31.)

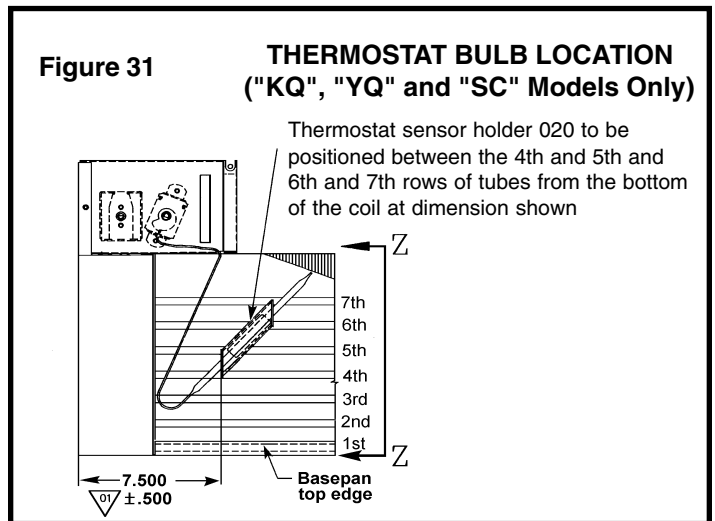
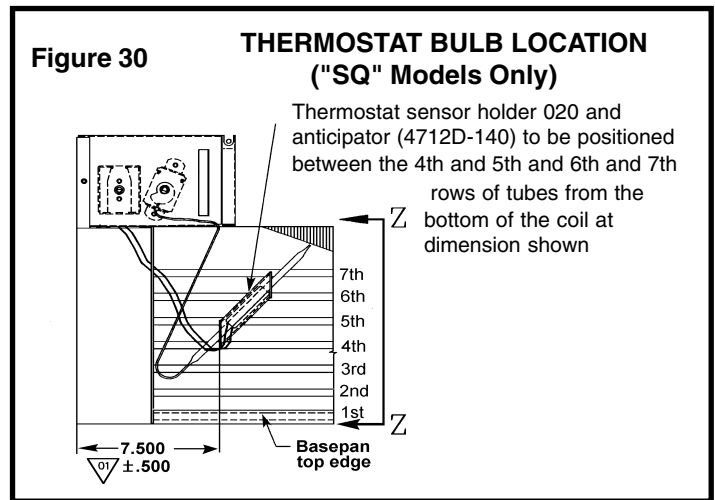

DEFROST THERMOSTAT

(Heat Pump Models Only)

(See Figure 32)

This thermostat is single pole - double throw with contacts between terminals "2" and "3" closing on temperature rise and contacts between terminals "2" and "1" closing on temperature fall. When the contacts between terminals "2" and "1" make, power is supplied to the heater element.

This control is dual purpose control that acts as an outdoor thermostat and defrost control.

When the sensing bulb, attached to the condenser coil, senses enough icing on the outdoor coil, it will interrupt power to the compressor and supply power to the heating element until the coil temperature reaches above 43°, then the heater will shut off and the unit will resume operating in the reverse cycle mode.

When the outdoor coil temperature drops below 20°, the unit will operate in electric heat mode continuously until the outdoor coil temperature rises above 43°.

The fan motor will not turn off when defrost occurs, and the 4-way valve will not reverse.

Figure 32

**DEFROST THERMOSTAT
(Heat Pump Models)**

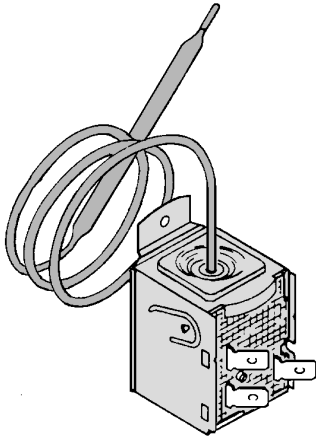

**DEFROST BULB LOCATION
(Heat Pump Models Only)**

(See Figure 33)

The defrost control bulb must be mounted securely and in the correct location to operate properly.

Figure 33

**DEFROST THERMOSTAT BULB
LOCATION (All Heat Pump Models)**
(See Figure 32)

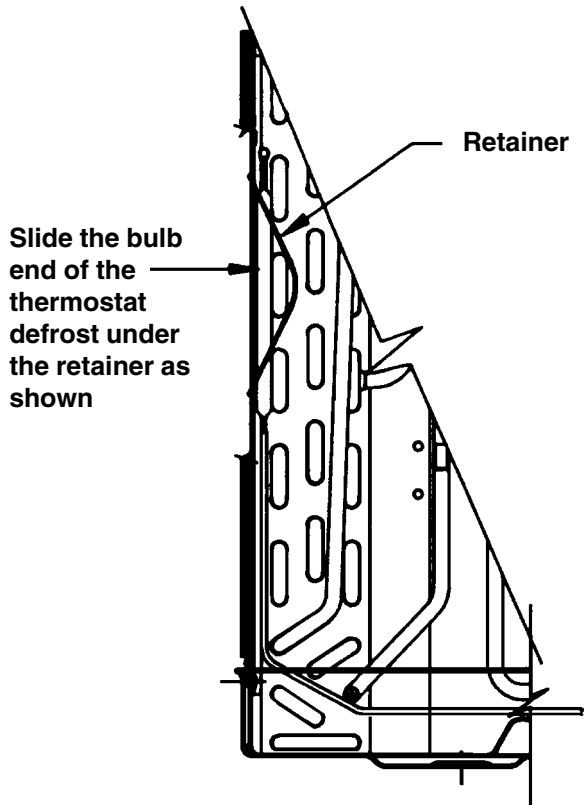

RESISTOR (Heat Anticipator) (See Figure 34)

Failure of the resistor will cause prolonged "off" and "on" cycles of the unit. When replacing a resistor, be sure and use the exact replacement. Resistor ratings are as follows:

- 115 Volt - 5,000 ohms 3 watt
- 230 Volt - 20,000 ohms 3 watt

Figure 34

RESISTOR

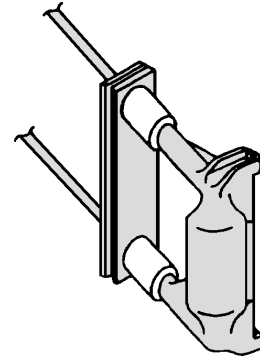

CAPACITOR, RUN (See Figure 35)

A run capacitor is wired across the auxiliary and main winding of a single phase permanent split capacitor motor such as the compressor and fan motor. A single capacitor can be used for each motor or a dual rated capacitor can be used for both.

The capacitor's primary function is to reduce the line current while greatly improving the torque characteristics of a motor. The capacitor also reduces the line current to the motor by improving the power factor of the load. The line side of the capacitor is marked with a red dot and is wired to the line side of the circuit.

CAPACITOR - TEST

1. Remove capacitor from unit.
2. Check for visual damage such as bulges, cracks, or leaks.

Figure 35

DUAL RATED RUN CAPACITOR HOOK-UP

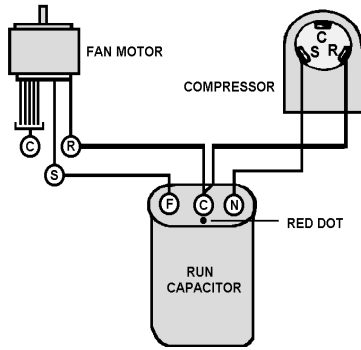

3. For dual rated, apply an ohmmeter lead to common (C) terminal and the other probe to the compressor (HERM) terminal. A satisfactory capacitor will cause a deflection on the pointer, then gradually move back to infinity.
4. Reverse the leads of the probe and momentarily touch the capacitor terminals. The deflection of the pointer should be two times that of the first check if the capacitor is good.
5. Repeat steps 3 and 4 to check fan motor capacitor.

NOTE: A shorted capacitor will indicate a low resistance and the pointer will move to the "0" end of the scale and remain there as long as the probes are connected.

An open capacitor will show no movement of the pointer when placed across the terminals of the capacitor.

CHECK VALVE

(See Figure 36)

A unique two-way check valve is used on the reverse cycle heat pumps. It is pressure operated and used to direct the flow of refrigerant through a single filter drier and to the proper capillary tube during either the heating or cooling cycle

Figure 36

ONE-WAY CHECK VALVE Heat Pump Models)

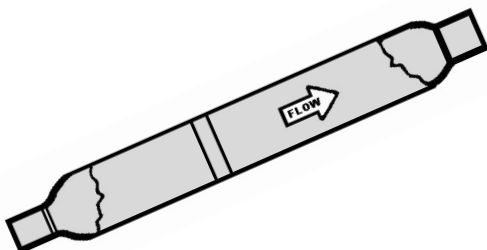

NOTE: The slide (check) inside the valve is made of teflon. Should it become necessary to replace the check valve, place a wet cloth around the valve to prevent overheating during the brazing operation.

CHECK VALVE OPERATION

In the cooling mode of operation, high pressure liquid enters the check valve forcing the slide to close the opposite port (liquid line) to the indoor coil. Refer to refrigerant flow chart. This directs the refrigerant through the filter drier and cooling capillary tube to the indoor coil.

In the heating mode of operation, high pressure refrigerant enters the check valve from the opposite direction, closing the port (liquid line) to the outdoor coil. The flow path of the refrigerant is then through the filter drier and heating capillary tube to the outdoor coil.

Failure of the slide in the check valve to seat properly in either mode of operation will cause flooding of the cooling coil. This is due to the refrigerant bypassing the heating or cooling capillary tube and entering the liquid line.

HEAT PUMPS: REVERSING VALVE

(See Figure 37)

A reversing valve is used to change the refrigerant flow within the system to permit heating or cooling.

The reversing valve consists of a main valve body which houses the slide and piston, plus a pilot valve which is activated by a solenoid.

There are three tubes connected to one side of the main valve body and one tube on the opposite side. The single tube is connected to the compressor discharge line. The center tube on the opposite side is the common suction line to the compressor. The outside tubes are connected to the indoor and outdoor coils.

The pivot valve is responsible for directing the refrigerant flow to the indoor or outdoor coil. There are three small tubes connected to the pilot valve body. The center pilot tube is the common pilot tube and is connected to the center suction line. The outside tubes are connected to each end of the main valve body. The pilot valve consists of a needle valve and spring.

When the solenoid is de-energized, the spring tension closes one pilot port while the other remains open. When the solenoid is energized, the opposite end is closed. The piston in the main valve is pressure operated and will always travel in the direction of the open pilot tube port which provides a path to the center tube. Pressure which will increase in the opposite side of the valve will escape through a bleed port located in each piston. When de-energized, the valve will be in the cooling position.

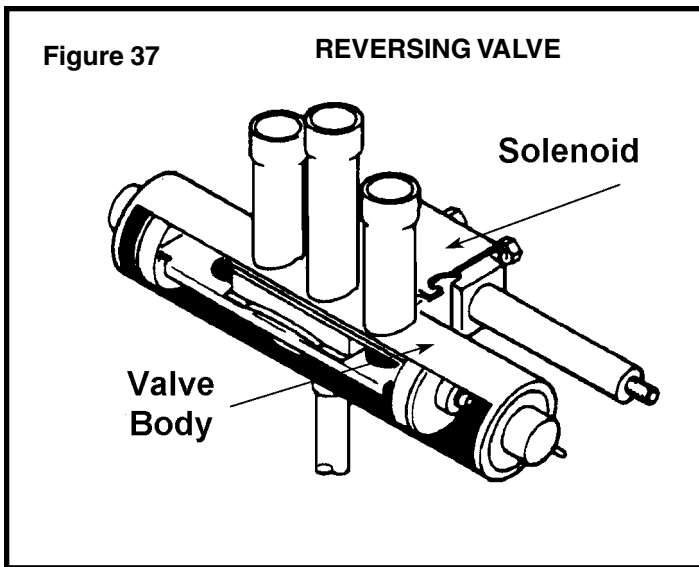

SOLENOID COIL
(Heat Pump Models Only) (See Figure 37)

The solenoid coil is an electromagnetic type coil mounted on the reversing valve and is energized during the operation of the compressor in the heating cycle.

Should the reversing valve fail to shift during the heating cycle, test the solenoid coil.

TO TEST:

1. Disconnect power to unit.
2. Disconnect coil leads.
3. Attach probes of an ohmmeter to each coil lead and check for continuity.

NOTE: Do not start unit with solenoid coil removed from valve, or do not remove coil after unit is in operation. This will cause the coil to burn out.

TESTING REVERSING VALVE

Occasionally, the reversing valve may stick in the heating or cooling position or in the mid-position.

When stuck in the mid-position, part of the discharge gas from the compressor is directed back to the suction side, resulting in excessively high suction pressure.

Check the operation of the valve by starting the system and switching the operation from "Cooling" to "Heating" and then back to "Cooling". Do not hammer on valve.

If valve fails to change its position, test the voltage to the valve coil while the system is in the heating cycle. If voltage to coil is satisfactory, replace reversing valve.

Should the valve fail to shift from cooling to heating, block the air flow through the outdoor coil and allow the discharge pressure to build in the system. Then switch the system from heating to cooling.

If the valve is stuck in the heating position, block the air flow through the indoor coil and allow discharge pressure to build in the system. Then switch the system from heating to cooling.

Should the valve fail to shift in either position after increasing the discharge pressure, replace the valve.

NOTE: When brazing a reversing valve into the system, it is of extreme importance that the temperature of the valve does not exceed 250° F at any time.

Wrap the reversing valve with a large rag saturated with water. "Re-wet" the rag and thoroughly cool the valve after each brazing operation of the four joints involved.

The wet rag around the reversing valve will eliminate conduction of heat to the valve body when brazing the line connection.

VALVE, DRAIN PAN (See Figure 38)

During the cooling mode of operation, condensate which collects in the drain pan is picked up by the condenser fan blade and sprayed onto the condenser coil. This assists in cooling the refrigerant plus evaporating the water.

During the heating mode of operation, it is necessary that water be removed to prevent it from freezing during cold outside temperatures. This could cause the condenser fan blade to freeze in the accumulated water and prevent it from turning.

To provide a means of draining this water, a bellows type drain valve is installed over a drain opening in the base pan.

This valve is temperature sensitive and will open when the outside temperature reaches 40°F. The valve will close gradually as the temperature rises above 40°F to fully close at 60°F.

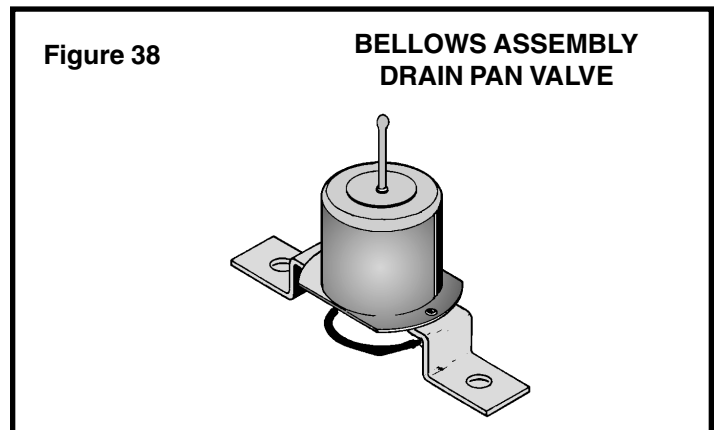

HEATING ELEMENT (See Figure 39)

All heat pumps and electric heat models are equipped with a heating element with the exception of the YS09J10. The "YS", "ES" and "EK12" models are equipped with a 3.3 KW element. The "YM", "EM" and "EK18" models are equipped with a 4.0 KW element. The "YL" and "EL" models are equipped with a 5.2 KW element.

The heating element contains a fuse link and a heater limit switch. The fuse link is in series with the power supply and will open and interrupt the power when the temperature reaches 161.6°F, or a short circuit occurs in the heating element. Once the fuse link separates, a new fuse link must be installed. **NOTE: Always replace with the exact replacement.**

The heater element has a high limit control. This control is a bimetal thermostat mounted in the top of the heating element.

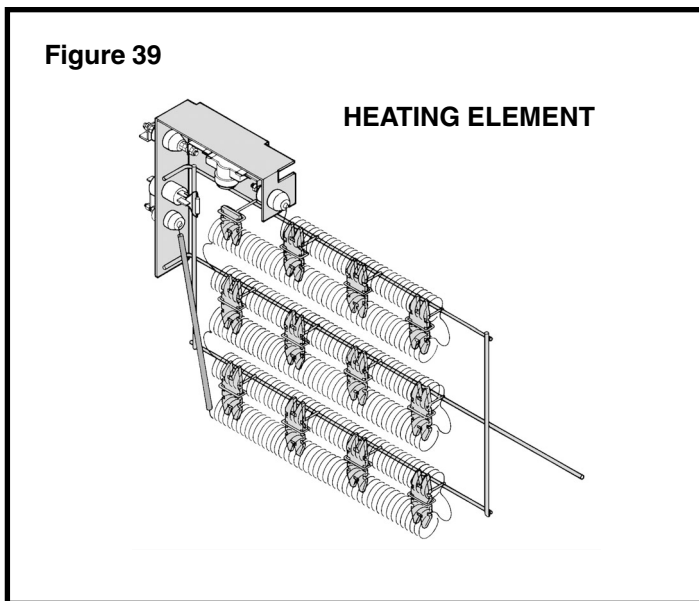

Should the fan motor fail or filter become clogged, the high limit control will open and interrupt power to the heater before reaching an unsafe temperature condition.

The control is designed to open at 110°F ±6°F. Test continuity below 110°F and for open above 110°F.

The heating element for the "Y" model is energized by an outdoor thermostat. The outdoor thermostat is adjusted at a predetermined temperature to bring on the heating element and turn off the compressor. The room thermostat will then control the cycling of the element when the selected indoor temperature is reached.

Testing of the elements can be made with an ohmmeter across the terminals after the connecting wires have been removed. A cold resistance reading of approximately 14.5 ohms for the 3.3 KW heater, 11.9 ohms for the 4.0 KW heater and 9.15 ohms for the 5.2 KW heater should be registered.

SEALED REFRIGERATION SYSTEM REPAIRS

IMPORTANT

ANY SEALED SYSTEM REPAIRS TO HEAT PUMP MODELS REQUIRES THE INSTALLATION OF A SUCTION LINE DRIER IN THE SUCTION LINE BETWEEN THE EVAPORATOR AND THE REVERSING VALVE.

EQUIPMENT REQUIRED

1. Voltmeter
2. Ammeter
3. Ohmmeter
4. E.P.A. Approved Refrigerant Recovery System.
5. Vacuum Pump (capable of 200 microns or less vacuum.)
6. Acetylene Welder
7. Electronic Halogen Leak Detector (G.E. Type H-6 or equivalent.)
8. Accurate refrigerant charge measuring device such as:
 - a. Balance Scales - 1/2 oz. accuracy
 - b. Charging Board - 1/2 oz. accuracy
9. High Pressure Gauge - (0 - 400 lbs.)
10. Low Pressure Gauge - (30 - 150 lbs.)
11. Vacuum Gauge - (0 - 1000 microns)

EQUIPMENT MUST BE CAPABLE OF:

1. Recovery CFC's as low as 5%.
2. Evacuation from both the high side and low side of the system simultaneously.
3. Introducing refrigerant charge into high side of the system.
4. Accurately weighing the refrigerant charge actually introduced into the system.
5. Facilities for flowing nitrogen through refrigeration tubing during all brazing processes.

HERMETIC COMPONENT REPLACEMENT

The following procedure applies when replacing components in the sealed refrigeration circuit or repairing refrigerant leaks. (Compressor, condenser, evaporator, capillary tube, refrigerant leaks, etc.)

1. Recover the refrigerant from the system at the process tube located on the high side of the system by installing a line tap on the process tube. Apply gauge from process tube to EPA approved gauges from process tube to EPA approved recovery system. Recover CFC's in system to at least 5%.
2. Cut the process tube below pinch off on the suction side of the compressor.
3. Connect the line from the nitrogen tank to the suction process tube.
4. Drift dry nitrogen through the system and un-solder the more distant connection first. (Filter drier, high side process tube, etc.)
5. Replace inoperative component, and always install a new filter drier. Drift dry nitrogen through the system when making these connections.
6. Pressurize system to 30 PSIG with proper refrigerant and boost refrigerant pressure to 150 PSIG with dry nitrogen.
7. Leak test complete system with electric halogen leak detector, correcting any leaks found.
8. Reduce the system to zero gauge pressure.
9. Connect vacuum pump to high side and low side of system with deep vacuum hoses, or copper tubing. (Do not use regular hoses.)
10. Evacuate system to maximum absolute holding pressure of 200 microns or less. NOTE: This process can be speeded up by use of heat lamps, or by breaking the vacuum with refrigerant or dry nitrogen at 5,000 microns. Pressure system to 5 PSIG and leave in system a minimum of 10 minutes. Release refrigerant, and proceed with evacuation of a pressure of 200 microns or less.
11. Break vacuum by charging system from the high side with the correct amount of refrigerant specified. This will prevent boiling the oil out of the crankcase.

NOTE: If the entire charge will not enter the high side, allow the remainder to enter the low side in small increments while operating the unit.

12. Restart unit several times after allowing pressures to stabilize. Pinch off process tubes, cut and solder the ends. Remove pinch off tool, and leak check the process tube ends.

SPECIAL PROCEDURE IN THE CASE OF COMPRESSOR MOTOR BURNOUT

1. Recover all refrigerant and oil from the system.
2. Remove compressor, capillary tube and filter drier from the system.
3. Flush evaporator condenser and all connecting tubing with dry nitrogen or equivalent, to remove all contamination from system. Inspect suction and discharge line for carbon deposits. Remove and clean if necessary.
4. Reassemble the system, including new drier strainer and capillary tube.
5. Proceed with processing as outlined under hermetic component replacement.

ROTARY COMPRESSOR SPECIAL TROUBLESHOOTING AND SERVICE

Basically, troubleshooting and servicing rotary compressors is the same as on the reciprocating compressor with only a few exceptions.

1. Because of the spinning motion of the rotary, the mounts are critical. If vibration is present, check the mounts carefully.
2. The electrical terminals on the rotary are in a different order than the reciprocating compressors. The terminal markings are on the cover gasket. Use your wiring diagram to insure correct connections.

REFRIGERANT CHARGING

NOTE: BECAUSE THE RAC SYSTEM IS A SEALED SYSTEM, SERVICE PROCESS TUBES WILL HAVE TO BE INSTALLED. FIRST INSTALL A LINE TAP AND REMOVE REFRIGERANT FROM SYSTEM. MAKE NECESSARY SEALED SYSTEM REPAIRS AND VACUUM SYSTEM. CRIMP PROCESS TUBE LINE AND SOLDER END SHUT. DO NOT LEAVE A SERVICE VALVE IN THE SEALED SYSTEM.

Proper refrigerant charge is essential to proper unit operation. Operating a unit with an improper refrigerant charge will result in reduced performance (capacity) and/or efficiency. Accordingly, the use of proper charging methods during servicing will insure that the unit is functioning as designed and that its compressor will not be damaged.

Too much refrigerant (overcharge) in the system is just as bad (if not worse) than not enough refrigerant (undercharge). They both can be the source of certain compressor failures if they remain uncorrected for any period of time. Quite often, other problems (such as low air

refrigerant charge problems. The refrigerant circuit diagnosis chart will assist you in properly diagnosing these systems.

An overcharged unit will at times return liquid refrigerant (slugging) back to the suction side of the compressor eventually causing a mechanical failure within the compressor. This mechanical failure can manifest itself as valve failure, bearing failure, and/or other mechanical failure. The specific type of failure will be influenced by the amount of liquid being returned, and the length of time the slugging continues.

Not enough refrigerant (Undercharge) on the other hand, will cause the temperature of the suction gas to increase to the point where it does not provide sufficient cooling for the compressor motor. When this occurs, the motor winding temperature will increase causing the motor to overheat and possibly cycle open the compressor overload protector. Continued overheating of the motor windings and/or cycling of the overload will eventually lead to compressor motor or overload failure.

METHOD OF CHARGING

The acceptable method for charging the RAC system is the Weighed in Charge Method. The weighed in charge method is applicable to all units. It is the preferred method to use, as it is the most accurate.

The weighed in method should always be used whenever a charge is removed from a unit such as for a leak repair, compressor replacement, or when there is no refrigerant charge left in the unit. To charge by this method, requires the following steps:

1. Install a piercing valve to remove refrigerant from the sealed system. (Piercing valve must be removed from the system before recharging.)
2. Recover Refrigerant in accordance with EPA regulations.
3. Install a process tube to sealed system.
4. Make necessary repairs to system.
5. Evacuate system to 250 - 300 microns or less.
6. Weigh in refrigerant with the property quantity of R-22 refrigerant.
7. Start unit, and verify performance.
8. Crimp the process tube and solder the end shut.

NOTE: In order to access the sealed system it will be necessary to install Schrader type fittings to the process tubes on the discharge and suction of the compressor. Proper recovery refrigerant procedures need to be adhered to as outlined in EPA Regulations. THIS SHOULD ONLY BE ATTEMPTED BY QUALIFIED SERVICE PERSONNEL.

Undercharged Refrigerant Systems

An undercharged system will result in poor performance (low pressures, etc.) in both the heating and cooling cycle.

Whenever you service a unit with an undercharge of refrigerant, always suspect a leak. The leak must be repaired before charging the unit.

To check for an undercharged system, turn the unit on, allow the compressor to run long enough to establish working pressures in the system (15 to 20 minutes).

During the cooling cycle you can listen carefully at the exit of the metering device into the evaporator; an intermittent hissing and gurgling sound indicates a low refrigerant charge.

Intermittent frosting and thawing of the evaporator is another indication of a low charge, however, frosting and thawing can also be caused by insufficient air over the evaporator.

Checks for an undercharged system can be made at the compressor. If the compressor seems quieter than normal, it is an indication of a low refrigerant charge. A check of the amperage drawn by the compressor motor should show a lower reading. (Check the Unit Specification.) After the unit has run 10 to 15 minutes, check the gauge pressures.

Gauges connected to system with an undercharge will have low head pressures and substantially low suction pressures.

NOTE: Heat pump refrigeration drawing

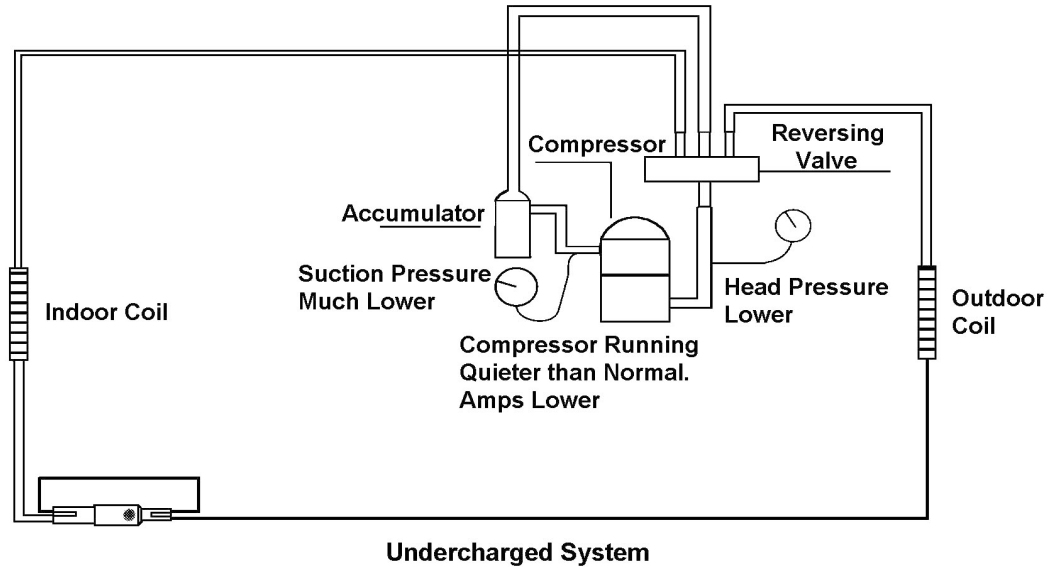

Overcharged Refrigerant Systems

Compressor amps will be near normal or higher. Noncondensables can also cause these symptoms. To confirm, remove some of the charge, if conditions improve, system may be overcharged. If conditions don't improve, Noncondensables are indicated.

Whenever an overcharged system is indicated, always make sure that the problem is not caused by air flow problems. Improper air flow over the evaporator coil may indicate some of the same symptoms as an overcharged system.

An over charge can cause the compressor to fail, since it would be "slugged" with liquid refrigerant.

The charge for any system is critical. When the compressor is noisy, suspect an overcharge, when you are sure that the air quantity over the evaporator coil is correct. Icing of the evaporator will not be encountered because the refrigerant will boil later if at all. Gauges connected to system will usually have higher head pressure (depending upon amount of overcharge). Suction pressure should be slightly higher.

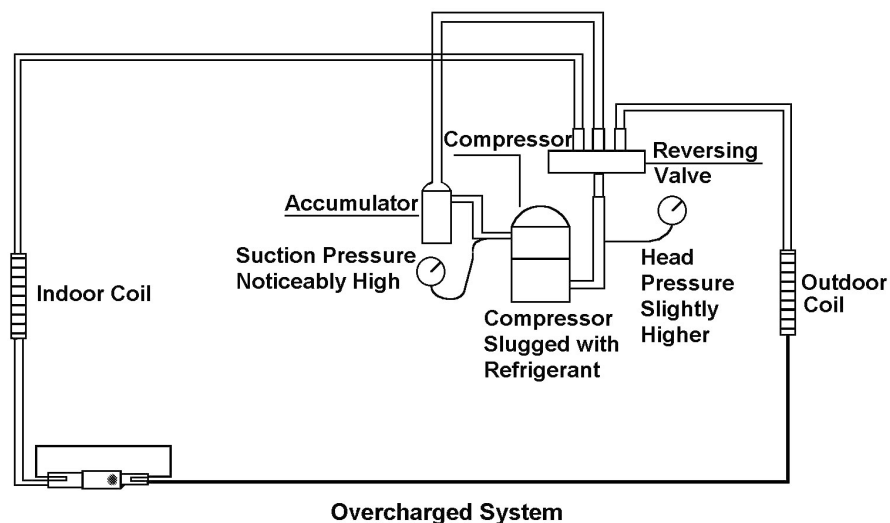

Restricted Refrigerant System

A quick check for either condition begins at the evaporator. With a partial restriction, there may be gurgling sounds at the metering device entrance to the evaporator. The evaporator in a partial restriction could be partially frosted or have an ice ball close to the entrance of the metering device. Frost may continue on the suction line back to the compressor.

Often a partial restriction of any type can be found by feel, as there is a temperature difference from one side of the restriction to the other.

With a complete restriction, there will be no sound at the metering device entrance. An amperage check of the compressor with a partial restriction may show normal current when compared to the unit specification. With a complete restriction the current drawn may be considerably less than normal, as the compressor is running in a deep vacuum (no load.) Much of the area of the condenser will be relatively cool since most or all of the liquid refrigerant will be stored there.

The following conditions are based primarily on a system in the cooling mode.

Troubleshooting a restricted refrigerant system can be difficult. The following procedures are the more common problems and solutions to these problems. There are two types of refrigerant restrictions: Partial restrictions and complete restrictions.

A partial restriction allows some of the refrigerant to circulate through the system.

With a complete restriction there is no circulation of refrigerant in the system.

Restricted refrigerant systems display the same symptoms as a "low-charge condition."

When the unit is shut off, the gauges may equalize very slowly.

Gauges connected to a completely restricted system will run in a deep vacuum. When the unit is shut off, the gauges will not equalize at all.

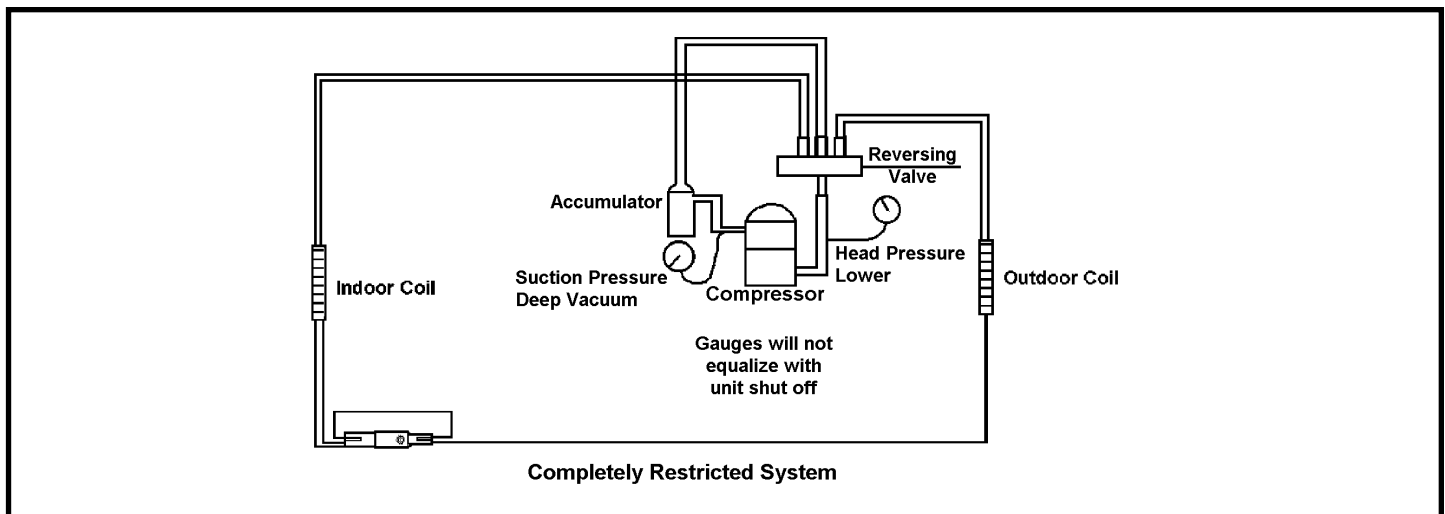
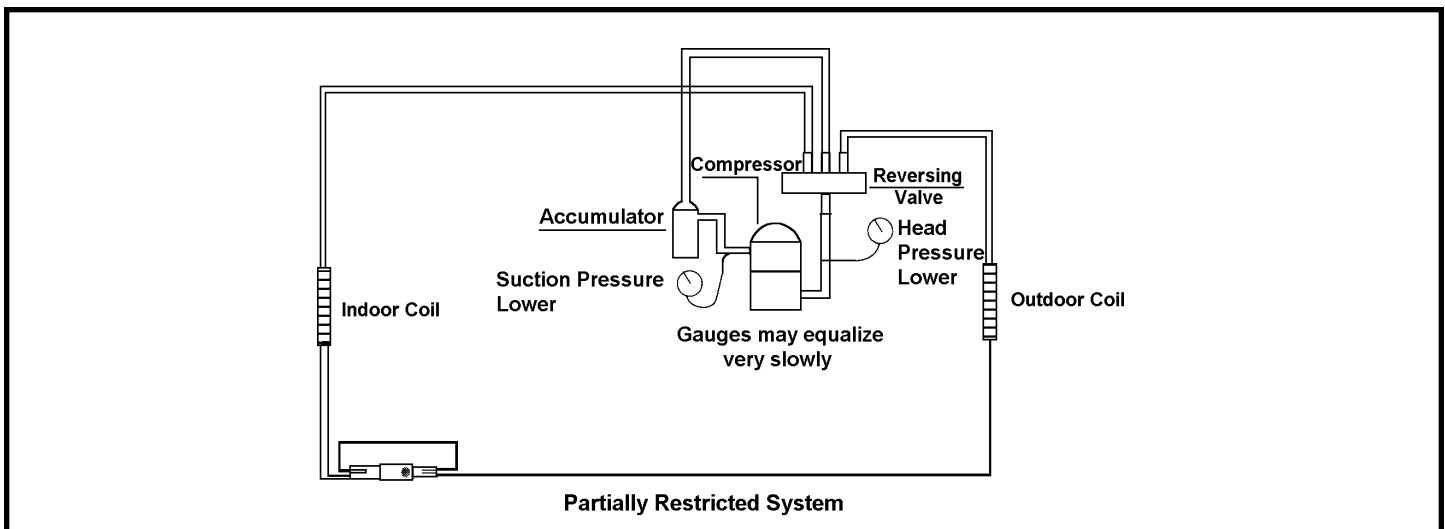

Routine Maintenance

NOTE: Units are to be inspected and serviced by qualified service personnel only.

1. Clean the unit air intake filter at least every 250 to 300 fan hours of operation or when the unit's indicator light is on if so equipped. Clean the filters with a mild detergent in warm water and allow to dry thoroughly before reinstalling.
2. The indoor coil (evaporator coil), the outdoor coil (condenser coil) and base pan should be inspected periodically (yearly or bi-yearly) and cleaned of all debris (lint, dirt, leaves, paper, etc.). Clean the coils and base pan with a soft brush and compressed air or vacuum. If using a pressure washer, be careful not to bend the aluminium fin pack. Use a sweeping up and down motion in the direction of the vertical aluminum fin pack when pressure cleaning coils. Cover all electrical components to protect them from water or spray. Allow the unit to dry thoroughly before reinstalling it in the sleeve.

NOTE: Do not use a caustic coil cleaning agent on coils or base pan. Use a biodegradable cleaning agent and degreaser.

Inspect the indoor blower housing, evaporator blade, condenser fan blade, and condenser shroud periodically (yearly or bi-yearly) and clean of all debris (lint, dirt, mold, fungus, etc.) Clean the blower housing area and blower wheel with an antibacterial / antifungal cleaner. Use a biodegradable cleaning agent and degreaser on condenser fan and condenser shroud. Use warm or cold water when rinsing these items. Allow all items to dry thoroughly before reinstalling them.

3. Periodically (at least yearly or bi-yearly): inspect all control components, both electrical and mechanical, as well as the power supply. Use proper testing instruments (voltmeter, ohmmeter, ammeter, wattmeter, etc.) to perform electrical tests. Use an air conditioning or refrigeration thermometer to check room, outdoor and coil operating temperatures. Use a sling psychrometer to measure wet bulb temperatures indoors and outdoors.
4. Inspect the surrounding area (inside and outside) to ensure that the units' clearances have not been compromised or altered.
5. Inspect the sleeve and drain system periodically (at least yearly or bi-yearly) and clean of all obstructions and debris. Clean both areas with an antibacterial and antifungal cleaner. Rinse both items thoroughly with water and ensure that the drain outlets are operating correctly. Check the sealant around the sleeve and reseal areas as needed.
6. Clean the front cover when needed. Use a mild detergent. Wash and rinse with warm water. Allow it to dry thoroughly before reinstalling it in the chassis.

TROUBLESHOOTING TOUCH TEST CHART TO SERVICE REVERSING VALVES

NORMAL FUNCTION OF VALVE								
VALVE OPERATING CONDITION	DISCHARGE TUBE from Compressor	SUCTION TUBE to Compressor	Tube to INSIDE COIL	Tube to OUTSIDE COIL	LEFT Pilot Capillary Tube	RIGHT Pilot Capillary Tube	NOTES:	
	1	2	3	4	5	6	* TEMPERATURE OF VALVE BODY ** WARMER THAN VALVE BODY	
							POSSIBLE CAUSES CORRECTIONS	
Normal Cooling	Hot	Cool	Cool as (2)	Hot as (1)	*TVB	TVB		
Normal Heating	Hot	Cool	Hot as (1)	Cool as (2)	*TVB	TVB		
MALFUNCTION OF VALVE								
Valve will not shift from cool to heat.	Check Electrical circuit and coil						No voltage to coil. Defective coil.	Repair electrical circuit. Replace coil.
	Check refrigeration charge						Low charge Pressure differential too high.	Repair leak, recharge system. Recheck system.
	Hot	Cool	Cool, as (2)	Hot, as (1)	*TVB	Hot	Pilot valve okay. Dirt in one bleeder hole.	Deenergize solenoid, raise head pressure, reenergize solenoid to break dirt loose. If unsuccessful, remove valve, wash out. Check on air before installing. If no movement, replace valve, add strainer to discharge tube, mount valve horizontally.
							Piston cup leak	Stop unit. After pressures equalize, restart with solenoid energized. If valve shifts, reattempt with compressor running. If still no shift, replace valve.
Valve will not shift from cool to heat.	Hot	Cool	Cool, as (2)	Hot, as (1)	*TVB	*TVB	Clogged pilot tubes.	Raise head pressure, operate solenoid to free. If still no shift, replace valve.
	Hot	Cool	Cool, as (2)	Hot, as (1)	Hot	Hot	Both ports of pilot open. (Back seat port did not close).	Raise head pressure, operate solenoid to free partially clogged port. If still no shift, replace valve.
	Warm	Cool	Cool, as (2)	Warm, as (1)	*TVB	Warm	Defective Compressor	
Starts to shift but does not complete reversal.	Hot	Warm	Warm	Hot	*TVB	Hot	Not enough pressure differential at start of stroke or not enough flow to maintain pressure differential.	Check unit for correct operating pressures and charge. Raise head pressure. If no shift, use valve with smaller port.
							Body damage	Replace valve
	Hot	Warm	Warm	Hot	Hot	Hot	Both ports of pilot open.	Raise head pressure, operate solenoid. If no shift, replace valve.
	Hot	Hot	Hot	Hot	*TVB	Hot	Body damage	Replace valve
							Valve hung up at mid-stroke. Pumping volume of compressor not sufficient to maintain reversal.	Raise head pressure, operate solenoid. If no shift, use valve with smaller ports.
Apparent leap in heating.	Hot	Cool	Hot, as (1)	Cool, as (2)	*TVB	*TVB	Piston needle on end of slide leaking.	Operate valve several times, then recheck. If excessive leak, replace valve.
	Hot	Cool	Hot, as (1)	Cool, as (2)	**	**	Pilot needle and piston needle leaking	Operate valve several times, then recheck. If excessive leak, replace valve.
Will not shift from heat to cool.	Hot	Cool	Hot, as (1)	Cool, as (2)	*TVB	*TVB	Pressure differential too high	Stop unit. Will reverse during equalization period. Recheck system
							Clogged pilot tube.	Raise head pressure, operate solenoid to free dirt. If still no shift, replace valve.
	Hot	Cool	Hot, as (1)	Cool, as (2)	Hot	*TVB	Dirt in bleeder hole.	Raise head pressure, operate solenoid. Remove valve and wash out. Check on air before reinstalling, if no movement, replace valve. Add strainer to discharge tube. Mount valve horizontally.
	Hot	Cool	Hot, as (1)	Cool, as (2)	Hot	*TVB	Piston cup leak	Stop unit. After pressures equalize, restart with solenoid deenergized. If valve shifts, reattempt with compressor running. If it still will not reverse while running, replace the valve.
	Hot	Cool	Hot, as (1)	Cool, as (2)	Hot	Hot	Defective pilot.	Replace valve.
	Warm	Cool	Warm, as (1)	Cool, as (2)	Warm	*TVB	Defective compressor.	

Valve operated satisfactorily PRIOR to compressor motor burnout – caused by dirt and small greasy particles inside the valve. TO CORRECT: Remove valve, thoroughly wash it out. Check on air before reinstalling, or replace valve. Add strainer and filter-drier to discharge tube between valve and compressor.

TROUBLESHOOTING COOLING

PROBLEM	POSSIBLE CAUSE	TO CORRECT
Compressor does not run.	Low voltage.	Check for voltage at compressor. 115 volt and 230 volt units will operate at 10% voltage variance
	Thermostat not set cold enough or inoperative.	Set thermostat to coldest position. Test thermostat and replace if inoperative.
	Compressor hums but cuts off on overload.	Hard start compressor. Direct test compressor. If compressor starts, add starting components.
	Open or shorted compressor windings.	Check for continuity and resistance.
	Open overload.	Test overload protector and replace if inoperative.
	Open capacitor.	Test capacitor and replace if inoperative.
	Inoperative system switch.	Test for continuity in all positions. Replace if inoperative.
	Broken, loose or incorrect wiring.	Refer to appropriate wiring diagram to check wiring.

PROBLEM	POSSIBLE CAUSE	TO CORRECT
Fan motor does not run.	Inoperative system switch.	Test switch and replace if inoperative.
	Broken, loose or incorrect wiring.	Refer to applicable wiring diagram.
	Open Capacitor.	Test capacitor and replace if inoperative.
	Fan speed switch open.	Test switch and replace if inoperative.
	Inoperative fan motor.	Test fan motor and replace if inoperative. (Be sure internal overload has had time to reset.)

PROBLEM	POSSIBLE CAUSE	TO CORRECT
Does not cool, or cools only slightly.	Undersized unit.	Refer to Sizing Charts.
	Thermostat open or inoperative.	Set to coldest position. Test thermostat and replace if necessary.
	Dirty filter.	Clean as recommended in Owner's Manual.
	Dirty or plugged condenser or evaporator coil.	Use steam or detergents to clean.
	Poor air circulation in area being cooled.	Adjust discharge air louvers. Use high fan speed.
	Fresh air or exhaust air door open on applicable models.	Close doors. Instruct customer on use of this feature.
	Low capacity – undercharge.	Check for leak and make repair.
	Compressor not pumping properly.	Check amperage draw against nameplate. If not conclusive, make pressure test.

PROBLEM	POSSIBLE CAUSE	TO CORRECT
Unit does not run.	Fuse blown or circuit tripped.	Replace fuse, reset breaker. If repeats, check fuse or breaker size. Check for shorts in unit wiring and components.
	Power cord not plugged in.	
	System switch in "Off" position.	Set switch correctly.
	Inoperative system switch.	Test for continuity in each switch position.
	Loose or disconnected wiring at switch or other components.	Check wiring and connections. Reconnect per wiring diagram.

PROBLEM	POSSIBLE CAUSE	TO CORRECT
Evaporator coil freezes up.	Dirty filter.	Clean as recommended in Owner's Manual.
	Restricted air flow.	Check for dirty or obstructed coil - clean as required.
	Inoperative thermostat.	Test for shorted thermostat or stuck contacts.
	Short of refrigerant.	De-ice coil and check for leak.
	Inoperative fan motor.	Test fan motor and replace if inoperative.
	Partially restricted capillary.	De-ice coil. Check temperature differential across coil. Touch test coil return bends for same temperature. Test for low running current.

PROBLEM	POSSIBLE CAUSE	TO CORRECT:
Compressor runs continually.	Excessive heat load.	Unit undersized. Test cooling performance of unit. Replace with larger unit.
	Restriction in line.	Check for partially iced coil. Check temperature split across coil.
Does not cycle off.	Refrigerant leak.	Check for oil at silver soldered connections. Check for partially iced coil. Check split across coil. Check for low running amperage.
	Thermostat contacts stuck	Check operation of thermostat. Replace if contacts remain closed.
	Thermostat incorrectly wired.	Refer to appropriate wiring diagram.

PROBLEM	POSSIBLE CAUSE	TO CORRECT:
Thermostat does not turn unit off.	Thermostat contacts stuck.	Replace thermostat.
	Thermostat set at coldest point.	Turn to higher temperature setting to see if the unit cycles off.
	Incorrect wiring.	Refer to appropriate wiring diagram.
	Unit undersized for area to be cooled.	Refer to Sizing Chart.

PROBLEM	POSSIBLE CAUSE	TO CORRECT
Compressor attempts to start, or runs for short periods only. Cycles on overload.	Overload inoperative. Opens too soon.	Check operation of unit. Replace overload if system operation is satisfactory.
	Compressor attempts to start before system pressures are equalized.	Allow a minimum of two (2) minutes for pressures to equalize before attempting to restart. Instruct customer of waiting period.
	Low or fluctuating voltage.	Check voltage with unit operating. Check for other appliances on circuit. Air conditioner should be on separate circuit for proper voltage, and be fused separately.
	Incorrect wiring.	Refer to appropriate wiring diagram.
	Shorted or incorrect capacitor.	Check by substituting a known good capacitor of correct rating.
	Restricted or low air flow through condenser coil.	Check for proper fan speed or blocked condenser. Check for kinked discharge line or restricted condenser.
	Compressor running abnormally hot.	Check amperage.

PROBLEM	POSSIBLE CAUSE	TO CORRECT
Thermostat does not turn unit on.	Loss of charge in thermostat bulb.	Place jumper across thermostat terminals to check if unit operates. If unit operates, replace thermostat. Check as above.
	Loose or broken parts in thermostat.	Refer to appropriate wiring diagram.
	Incorrect wiring.	

PROBLEM	POSSIBLE CAUSE	TO CORRECT
Noisy operation.	Poorly installed unit.	Refer to Installation Instructions for proper installation.
	Fan blade striking chassis.	Reposition - adjust motor mount.
	Compressor vibrating.	Check that compressor grommets have not deteriorated. Check that compressor mounting parts are not missing.
	Improperly mounted or loose cabinet parts.	Check assembly and parts for looseness, rubbing and rattling.

PROBLEM	POSSIBLE CAUSE	TO CORRECT
Water leaks into room.	Evaporator drain pan overflowing.	Clean obstructed drain trough.
	Condensation forming on base pan.	Evaporator drain pan broken or cracked. Reseal or replace.
	Poor installation resulting in rain entering room.	Check Installation Instructions. Reseal as required. Dirty evaporator coil - clean. Very high humidity level.
	Condensation on discharge grilles.	

PROBLEM	POSSIBLE CAUSE	TO CORRECT
Thermostat short cycles.	Thermostat differential too narrow.	Replace thermostat.
	Plenum gasket not sealing, allowing discharge air to short cycle thermostat.	Check gasket. Reposition or replace.
	Restricted coil or dirty filter.	Clean and advise customer of periodic cleaning of filter.
	Tubular insulation missing from top of thermostat bulb.	Replace tubular insulation on bulb. (Applicable models.)
	Thermostat bulb touching thermostat bulb support bracket.	Adjust bulb bracket. (Applicable models.)

TO CORRECT

PROBLEM	POSSIBLE CAUSE	TO CORRECT
Prolonged off-cycles. (automatic operation)	Anticipator (resistor) wire disconnected at thermostat or system switch.	Refer to appropriate wiring diagram.
	Anticipator (resistor shorted or open). (Applicable models.)	Disconnect plug from outlet. Remove resistor from bracket. Insert plug and depress "Cool" and "Fan - Auto (MoneySaver)" buttons. Place thermostat to warmest setting. Feel resistor for temperature. If no heat, replace resistor. Replace thermostat.
	Partial loss of charge in thermostat bulb causing a wide differential.	

PROBLEM	POSSIBLE CAUSE	TO CORRECT
Switches from cooling to heating.	Thermostat sticking.	Change room thermostat.
	Incorrect wiring.	Refer to appropriate wiring diagram.

PROBLEM	POSSIBLE CAUSE	TO CORRECT
Outside water leaks.	Evaporator drain pan cracked or obstructed.	Repair, clean or replace as required.
	Water in compressor area.	Detach shroud from pan and coil. Clean and remove old sealer. Reseal, reinstall and check.
	Obstructed condenser coil.	Steam clean.
	Fan blade and slinger ring improperly positioned.	Adjust fan blade to 1/2" clearance from condenser coil.

PROBLEM	POSSIBLE CAUSE	TO CORRECT
High indoor humidity.	Insufficient air circulation in air conditioned area.	Adjust louvers for best possible air circulation
	Oversized unit.	Operate in "Fan-Auto (MoneySaver)" position.
	Inadequate vapor barrier in building structure, particularly floors.	Advise customer.

Troubleshooting Heating

(Heat pumps)

PROBLEM	POSSIBLE CAUSE	TO CORRECT
No heating — fan operates.	Thermostat setting.	Set thermostat to a warmer position.
	Defective thermostat.	Replace — do not attempt to adjust.
	Compressor not operating.	Check compressor wiring. Check for open internal or external overload. Check wiring.
	Defective system switch.	Test system switch

PROBLEM	POSSIBLE CAUSE	TO CORRECT
Insufficient heating.	Restricted filter.	Clean as recommended in Owner's Manual.
	Outdoor thermostat. (Applicable models.)	Check if outdoor thermostat is energizing the heating element at its predetermined temperature setting Check control setting.
	Fresh air or exhaust door open.	

PROBLEM	POSSIBLE CAUSE	TO CORRECT
Fan operates in "constant" position, but not in "automatic" (MoneySaver).	Inoperative system switch.	Check continuity of switch.
	Incorrect wiring.	Check applicable wiring diagram.

PROBLEM	POSSIBLE CAUSE	TO CORRECT
Temperature varies from comfortable to overly warm.	Defective thermostat.	Incorrect differential setting. Replace thermostat.
	Heat anticipator (resistor) shorted. (Applicable models)	Check voltage to resistor. If voltage okay, remove resistor from thermostat bulb block. With current on, feel resistor for warmth. If no heat can be felt, replace anticipator.

PROBLEM	POSSIBLE CAUSE	TO CORRECT
Room temperature uneven. (Heating cycle)	Heat anticipator (resistor) shorted. (Applicable models.)	Disconnect power to unit. Remove resistor from thermostat bulb block. Plug in unit and allow to operate. Feel resistor for heat. If no heat is felt, replace resistor.
	Wide differential — partial loss of thermostat bulb charge.	Replace thermostat and check.
	Incorrect wiring.	Refer to appropriate wiring diagram. Resistor is energized during the "on" cycle of compressor or fan.

PROBLEM	POSSIBLE CAUSE	TO CORRECT
Unit will not defrost.	Incorrect wiring.	Refer to appropriate wiring diagram.
	Defrost control timer motor not advancing.	Check for voltage at "TM" and "TM1" on timer. If voltage, replace control.
	Defrost control out of calibration.	If outside coil temperature is 25° F or below, and preselected time limit has elapsed, replace the defrost control.
	Defrost control contacts stuck.	If the contacts remain closed between terminals "2" and "3" of the defrost control after preselected time interval has passed, replace control.
	Defrost control bulb removed from coil, or not making good coil contact.	Reinstall and assure that good bulb to coil contact is made.

PROBLEM	POSSIBLE CAUSE	TO CORRECT
Unit does not heat adequately.	Outdoor thermostat does not cut off compressor at the preselected temperature and bring on heating element.	Defective thermostat - replace.
	Fresh air or exhaust door open.	Check if operating properly. Instruct customer on proper use of control.
	Dirty filter.	Clean as recommended in Owner's Manual.
	Unit undersized.	Check heat rise across coil. Refer to performance data sheet on heat rise at various outdoor ambients. If heat rise is satisfactory, check if insulation can be added to attic or walls.

PROBLEM	POSSIBLE CAUSE	TO CORRECT
Unit cools when heat is called for.	Incorrect wiring.	Refer to applicable wiring diagram.
	Defective solenoid coil.	Check for continuity of coil.
	Reversing valve fails to shift.	Block condenser coil and switch unit to cooling. Allow pressure to build up in system, then switch to heating. If valve fails to shift, replace valve.
	Inoperative system switch.	Check for continuity of system switch.

PROBLEM	POSSIBLE CAUSE	TO CORRECT
Unit does not heat adequately.	Outdoor thermostat does not cut off compressor at the preselected temperature and bring on the heating element.	Defective thermostat — replace.
	Fresh air or exhaust door open.	Check if operating properly. Instruct customer on proper use of control.
	Dirty filter.	Clean as recommended in Owner's Manual
	Unit undersized.	Check heat rise across coil. Refer to performance data sheet on heat rise at various outdoor ambients. If heat rise is satisfactory, check if insulation can be added to attic or walls.

PROBLEM	POSSIBLE CAUSE	TO CORRECT
Unit cools when heat is called for.	Incorrect wiring.	Refer to applicable wiring diagram.
	Defective solenoid coil.	Check for continuity of coil.
	Reversing valve fails to shift.	Block condenser coil and switch unit to cooling. Allow pressure to build up in the system, then switch to heating. If valve fails to shift, replace valve.
	Inoperative system switch.	Check for continuity of system switch.

PROBLEM	POSSIBLE CAUSE	TO CORRECT
Cooling adequate — heating insufficient.	Heating capillary tube partially restricted.	Check for partially starved outer coil. Replace heating capillary tube.
	Check valve leaking internally.	Switch unit several times from heating to cooling. Check temperature rise across the coil. Refer to specification sheet for correct temperature rise.
	Reversing valve failing to shift completely — bypassing hot gas.	Deenergize solenoid coil, raise head pressure, energize solenoid to break loose. If valve fails to make complete shift, replace valve.

PROBLEM	POSSIBLE CAUSE	TO CORRECT
Compressor will not turn off and operate on heating element only during low outside ambients.	Outdoor thermostat. (Applicable models.)	Refer to the heating data on applicable models for the preselected temperature the compressor shuts off and the electric element is energized.

PROBLEM	POSSIBLE CAUSE	TO CORRECT
Compressor shuts off on outdoor thermostat but element does not heat.	Fuse link.	Check fuse link for continuity. If defective, replace.
	Heating element shorted.	Check amperage draw of element. If no amperage, replace.
	Incorrect wiring.	Check voltage to element. If voltage is okay, check wiring.
	Heat relay or heater contactor coil open.	Defective coil. Test coil for continuity.

Troubleshooting Heating

(Cooling/Electric Models)

PROBLEM	POSSIBLE CAUSE	TO CORRECT
Fan Operates – heating element does not come on.	Heater relay or contactor coil open.	Check continuity of coil.
	Heater relay or contactor stuck open, pitted or burned.	Inspect, test continuity with ohmmeter.
	High limit control open.	Check continuity – if open, replace.
	Open thermal fuse.	Check continuity. Check reason for failure.
	Open or shorted element.	Check voltage across heater terminals. Check amperage draw of heater.
	Loose connections.	Tighten all terminals.

PROBLEM	POSSIBLE CAUSE	TO CORRECT
Heating inadequate.	Restricted filter.	Clean as recommended in Owner's Manual.
	Cycling high limit control.	Control is set to open at 155°F ± 5°F and close at 130°F ± 8°F. If cycling prematurely, replace control. Check position of fresh air door control slide. Adjust cable if door does not close properly.
	Exhaust or fresh air door open.	

PROBLEM	POSSIBLE CAUSE	TO CORRECT
Fan operates in "Constant" position, but not in "Automatic" (Money-Saver).	Fan relay contacts open.	Check continuity of fan relay. NOTE: Some models have the fan relay energized during the heating cycle while others do not.
	Inoperative system switch.	Check continuity between terminals "L2" and "3" of the system switch.
	Loose connection.	Check connections on system switch and fan relay.

PROBLEM	POSSIBLE CAUSE	TO CORRECT
Long "off" and "on" cycles.	Heat anticipator (resistor) shorted.	Disconnect power to unit. Remove resistor from thermostat bulb block. Plug in unit and allow to operate. Feel resistor for heat. If no heat is felt, replace resistor.
	Defective thermostat.	Replace thermostat and check operation.

PROBLEM	POSSIBLE CAUSE	TO CORRECT
Fan motor does not operate in "Constant" or "MoneySaver" position.	Defective motor.	Check and replace.
	Open or shorted capacitor.	Replace capacitor and check.
	Condenser fan frozen to base pan.	Check if drain pan valve is open. If not, replace.
	Loose connections.	Check all connections. Check voltage to fan motor.

PROBLEM	POSSIBLE CAUSE	TO CORRECT
Cooling adequate, heating insufficient.	Heating capillary tube partially restricted. Check valve leaking internally.	Check for partially starved outer coil. Replace heating capillary tube.
		Switch unit several times from heating to cooling. Check temperature rise across coil. Refer to specification sheet for correct temperature rise.
	Reversing valve failing to shift completely – bypassing hot gas.	Deenergize solenoid coil, raise head pressure, energize solenoid to break loose. If valve fails to make complete shift, replace valve.

PROBLEM	POSSIBLE CAUSE	TO CORRECT
Compressor will not turn off and operate on heating element only during low outside ambients.	Outdoor thermostat. (Applicable models.)	Refer to the heating data on applicable models for the preselected temperature the compressor shuts off and the electric element is energized.

PROBLEM	POSSIBLE CAUSE	TO CORRECT
Compressor shuts off on outdoor thermostat but, element does not heat.	Fuse link.	Check fuse link for continuity. If defective, replace.
	Heating element shorted.	Check amperage draw of element. If no amperage, replace.
	Incorrect wiring.	Check voltage to element. If voltage is okay, check wiring.
	Heat relay or heater contactor coil open.	Defective coil. Test coil for continuity.

Troubleshooting Chart — Cooling

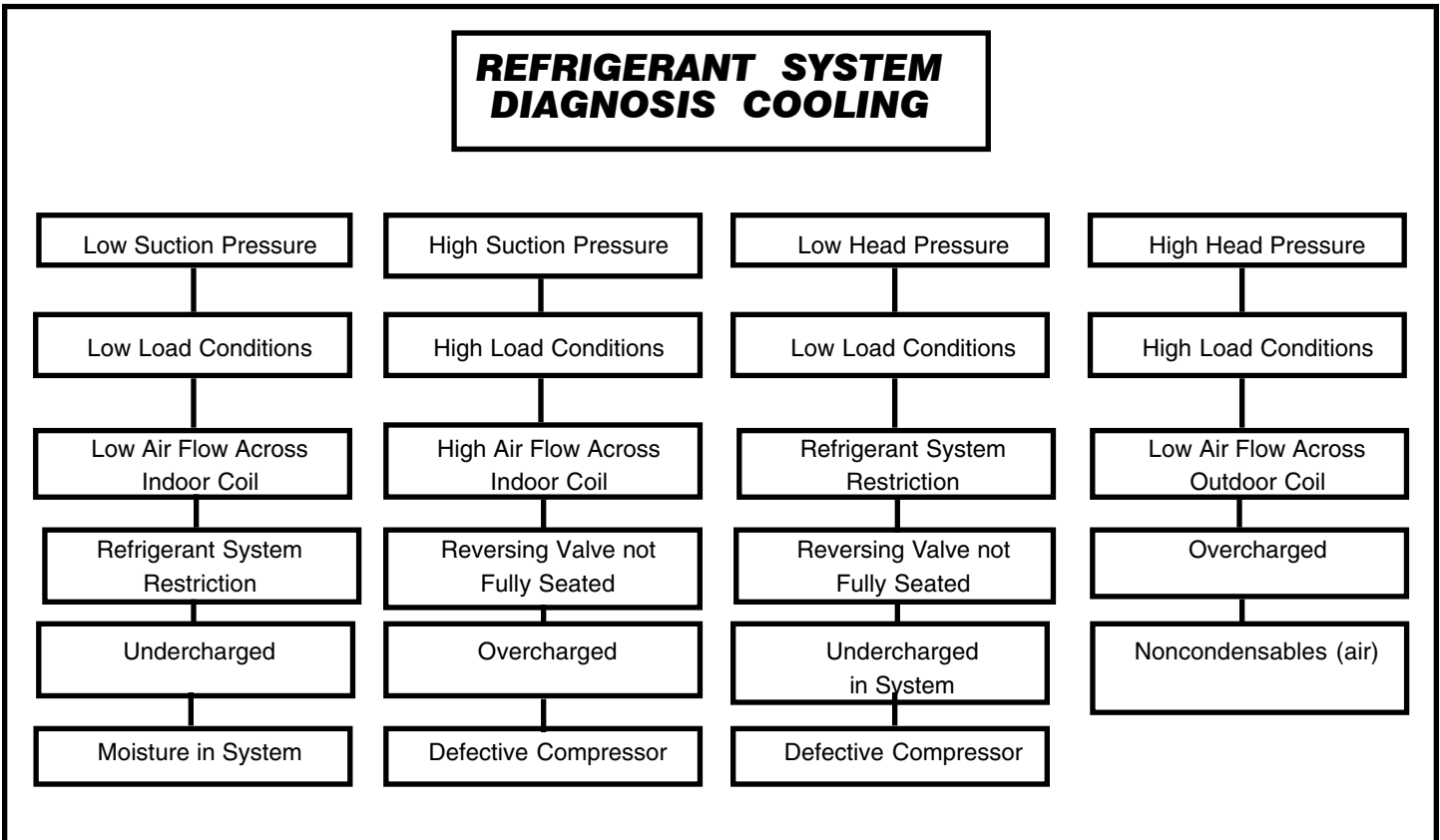

Troubleshooting Chart — Heating

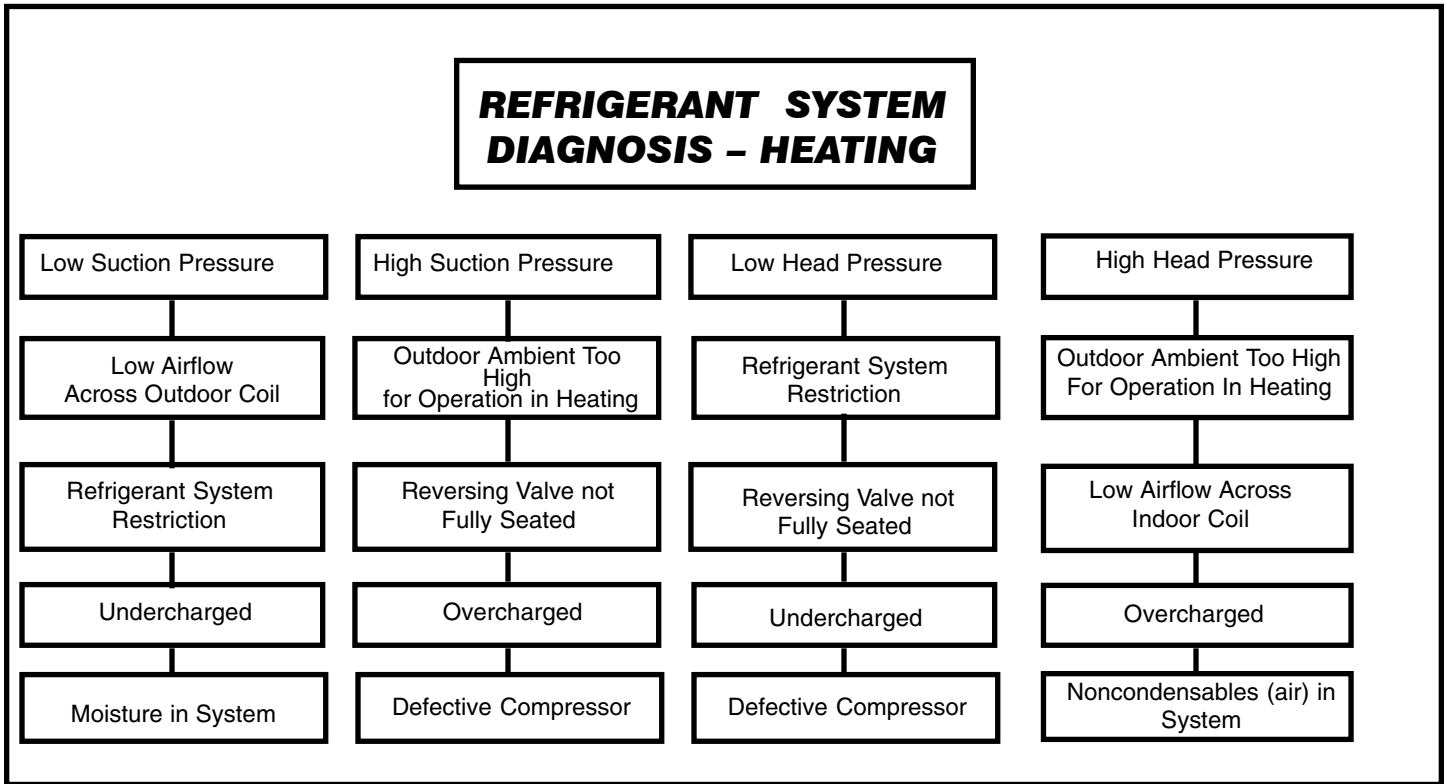

Electrical Troubleshooting Chart HEAT PUMP

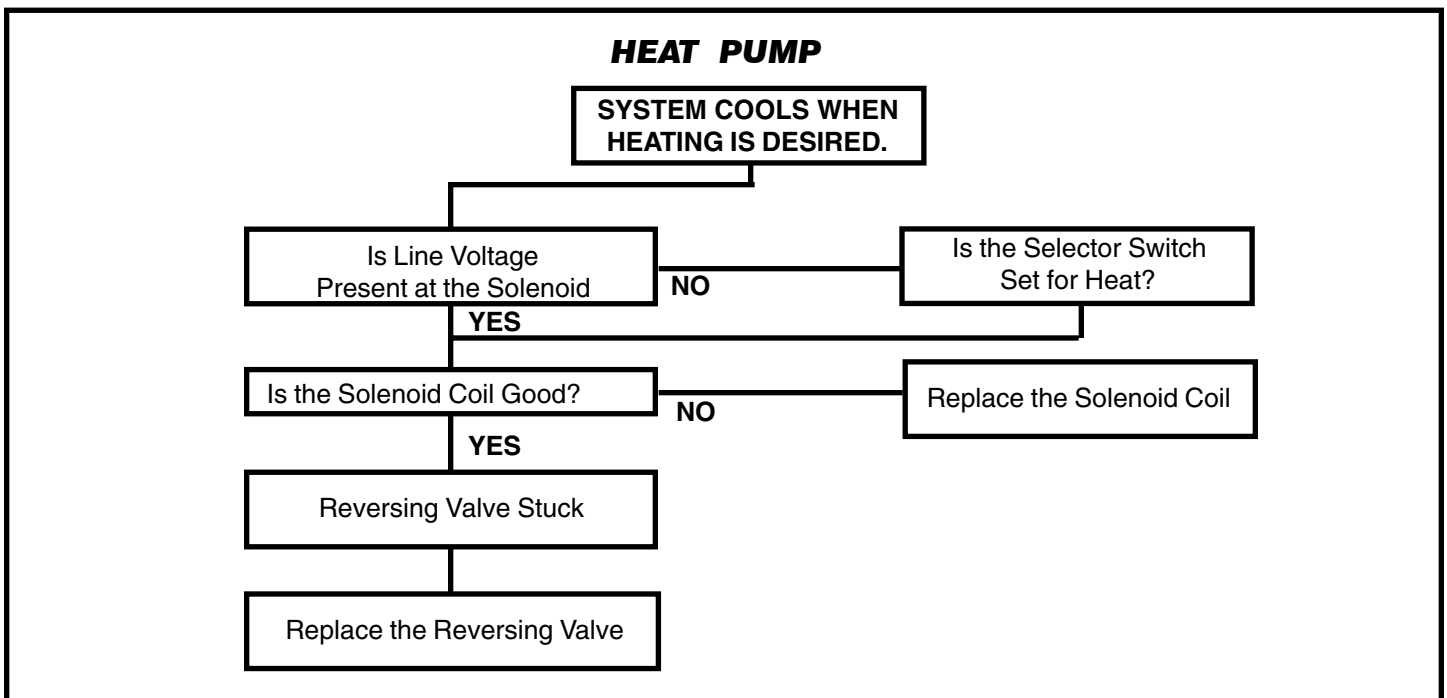

WIRING DIAGRAM FOR MODELS RS10J101, RS10J103, RS12J101, RS12J103, RS15J301, RM18J30, RM15J101, RM18J302, RM18J303

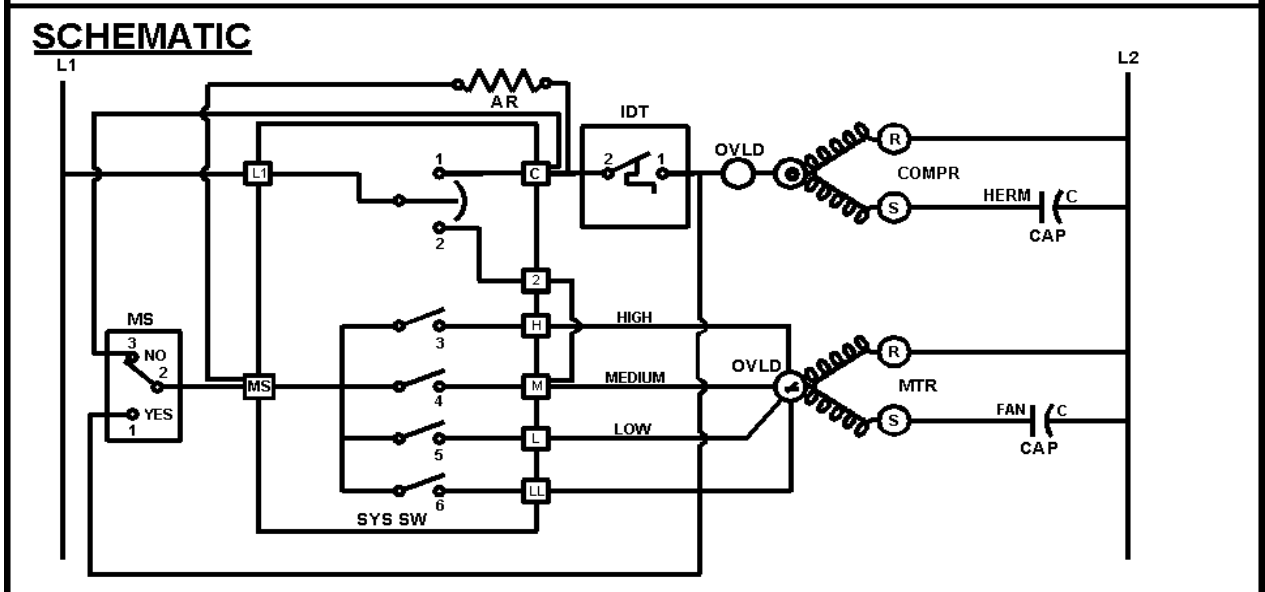
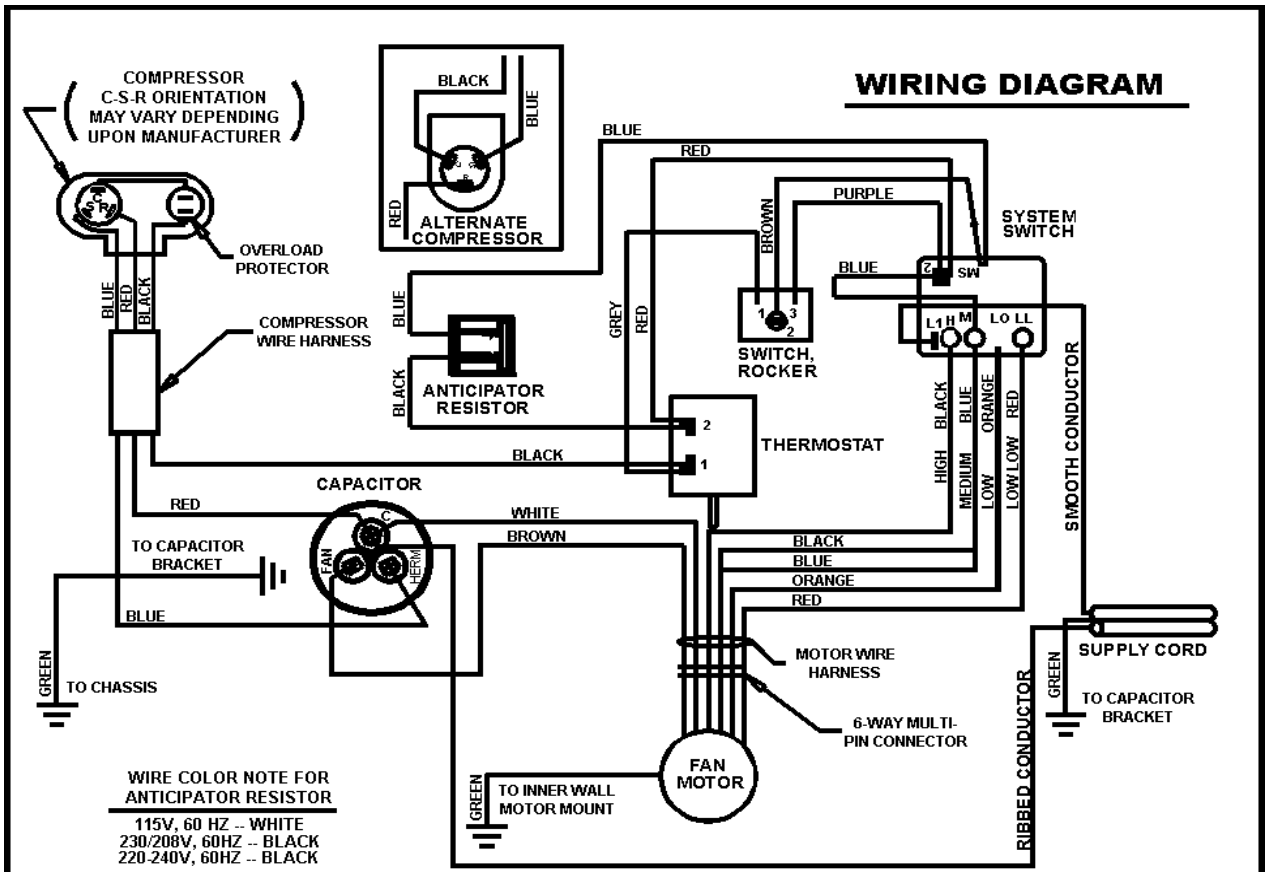

SWITCH LOGIC		X = OPEN O = CLOSED					
SWITCH POSITION	CIRCUIT	1	2	3	4	5	6
OFF		O	O	O	O	O	O
LOW COOL		X	O	O	O	X	O
MED COOL		X	O	X	O	O	O
HI COOL		X	O	X	O	O	O
FAN ONLY		O	X	O	O	O	O
LL COOL		X	O	O	O	O	X

LEGEND	
AR - ANTICIPATOR RESISTOR	-- GROUND LEAD
MS - MONEYSAVER / ROCKER SWITCH	-- COMBINATION TERMINAL
CAP - CAPACITOR	-- PLASTIC INSULATOR
COMP - COMPRESSOR	
MTR - FAN MOTOR	
OVLD - OVERLOAD PROTECTOR	
SYS SW - SYSTEM SWITCH	
IDT - INDOOR THERMOSTAT	

PART NO. 618-200-17 REV. 00

Wiring Diagram for Models SQ05J10A-1, SQ06J10A-1, SQ07J10A-1 & SQ08J10B-1

WIRING DIAGRAM

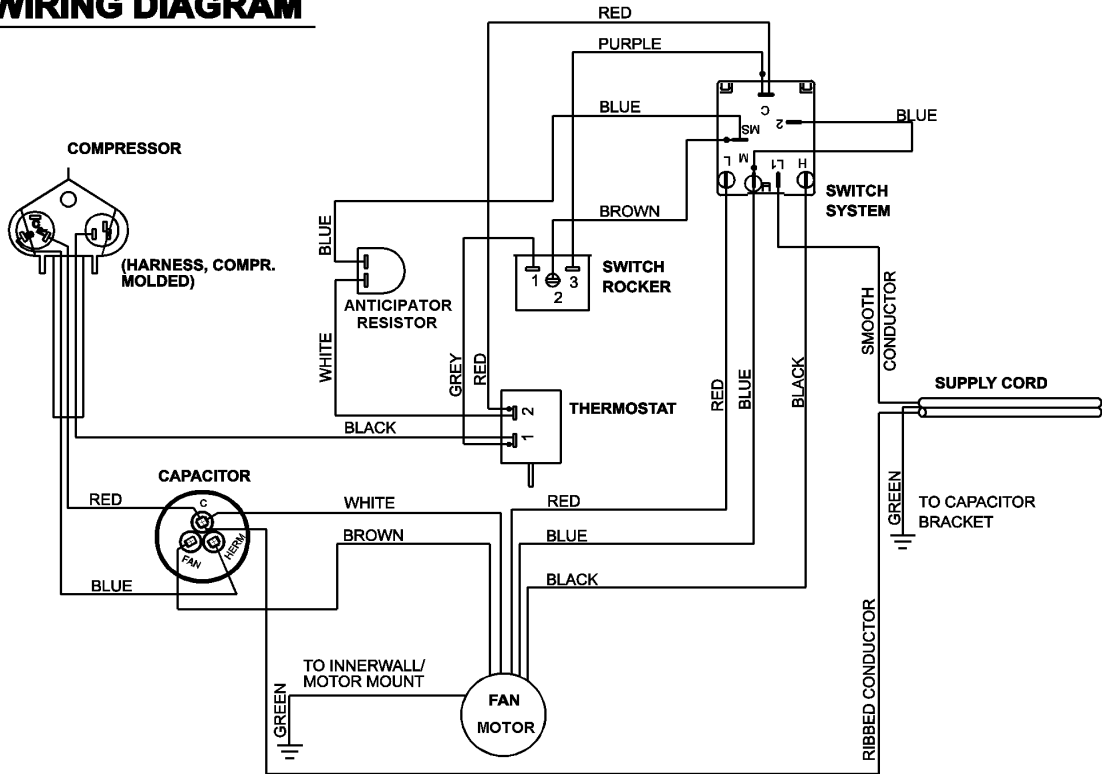

SCHEMATIC

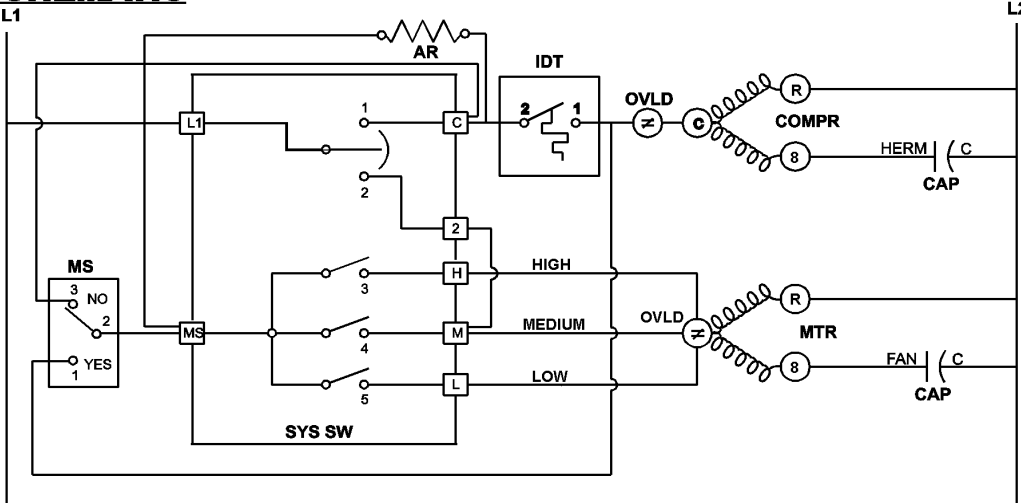

SWITCH LOGIC

X = CLOSED
0 = OPEN

SWITCH POSITION	1	2	3	4	5
OFF	0	0	0	0	0
LOW COOL	X	0	0	0	X
MED COOL	X	0	X	0	0
HI COOL	X	0	X	0	0
FAN ONLY	0	X	0	0	0

LEGEND

AR - ANTICIPATOR RESISTOR
 MS - MONEY SAVER/ROCKER SWITCH
 CAP - CAPACITOR
 COMPR - COMPRESSOR
 MTR - FAN MOTOR
 OVLD - OVERLOAD PROTECTOR
 SYS SW - SYSTEM SWITCH
 IDT - INDOOR THERMOSTAT

—||— - GROUND LEAD
 —○— - COMBINATION TERMINAL
 ● - PLASTIC INSULATOR

PART NO. 617-581-09 REV. 01

WIRING DIAGRAM FOR MODELS KQ05J10A-1, KQ05J10A-3, KQ06J10A-1, KQ06J10A-3, KQ08J10A-1

NOTE: WIRING AT THE "RUN" AND "START" TERMINALS IS OPPOSITE OF THE WIRING USED WITH TECHMSEH OR COPELAND COMPRESSORS

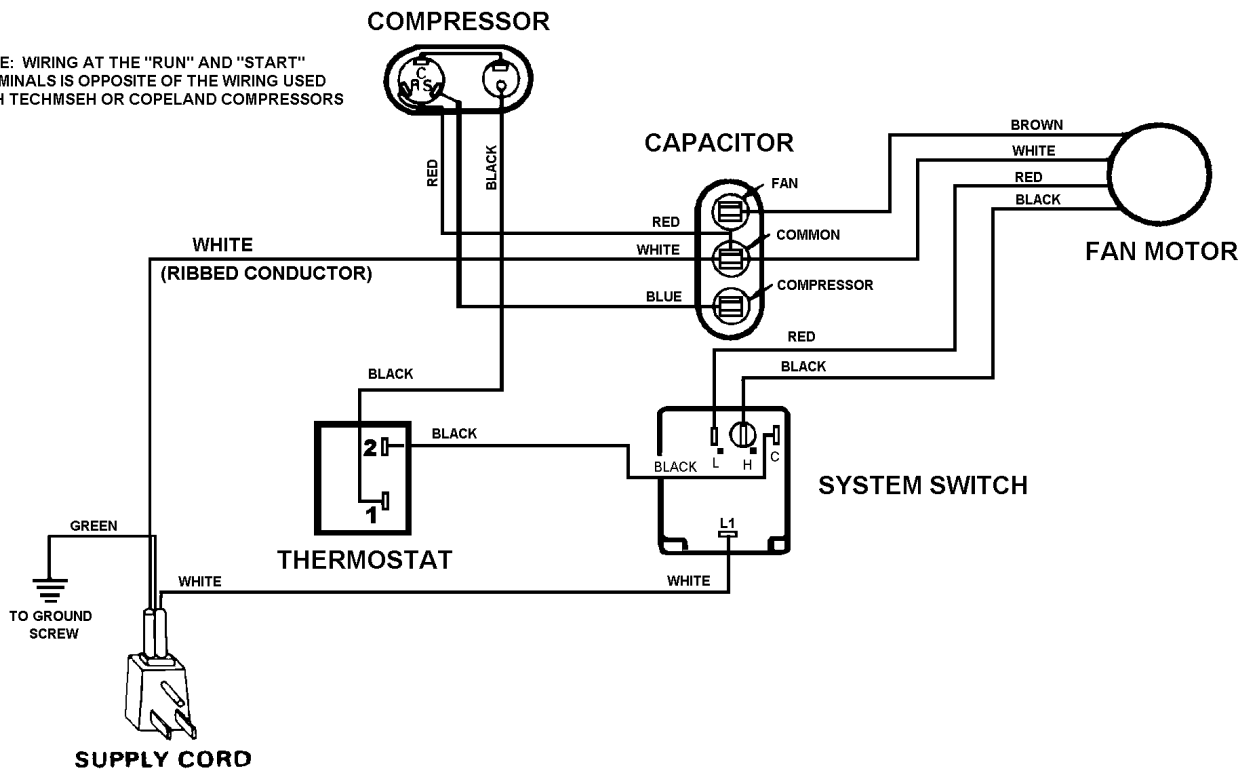

SYSTEM SWITCH SEQUENCE	
CW ROT	CONNECTION
OFF	ALL OPEN
HI FAN	L1 -- H
LO FAN	L1 -- L
LOW COOL	L1 -- L, L1 -- C
HI COOL	L1 -- H, L1 -- C

SCHEMATIC

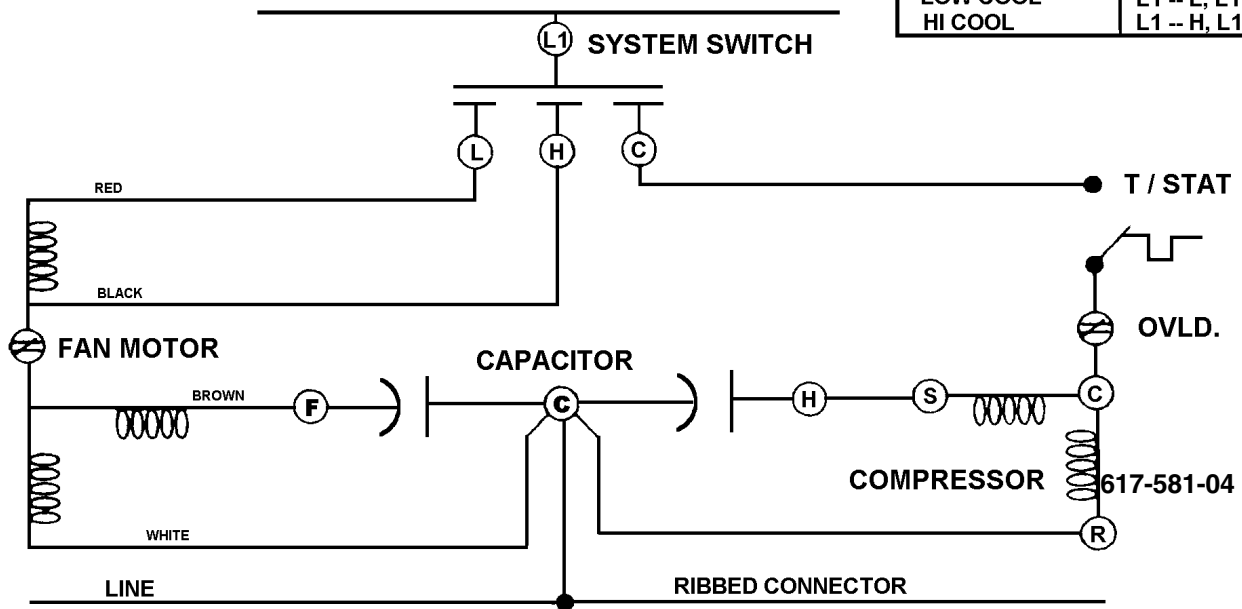

617-581-04

WIRING DIAGRAM FOR MODEL YQ06J10A-1

CAUTION
FOLLOW WIRING DIAGRAM EXACTLY
WHEN WIRING THE COMPRESSOR
THE RUN AND START TERM POSITIONS
VARY FROM CONVENTIONAL PRACTICE

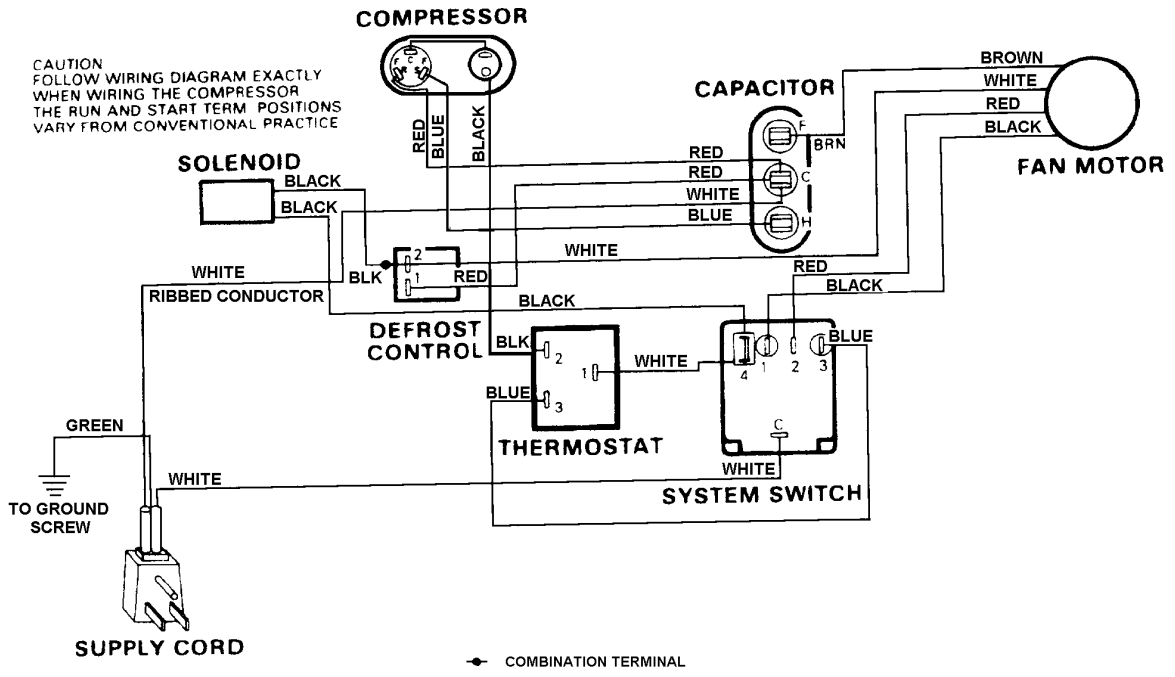

SCHEMATIC

SYSTEM SWITCH SEQUENCE
OFF: ALL OPEN
HI FAN: C TO 1 CLOSE
HI COOL: C TO 1, C TO 3 CLOSE
LO COOL: C TO 2, C TO 3 CLOSE
LO HEAT: C TO 2, C TO 4 CLOSE
HI HEAT: C TO 1, C TO 4 CLOSE

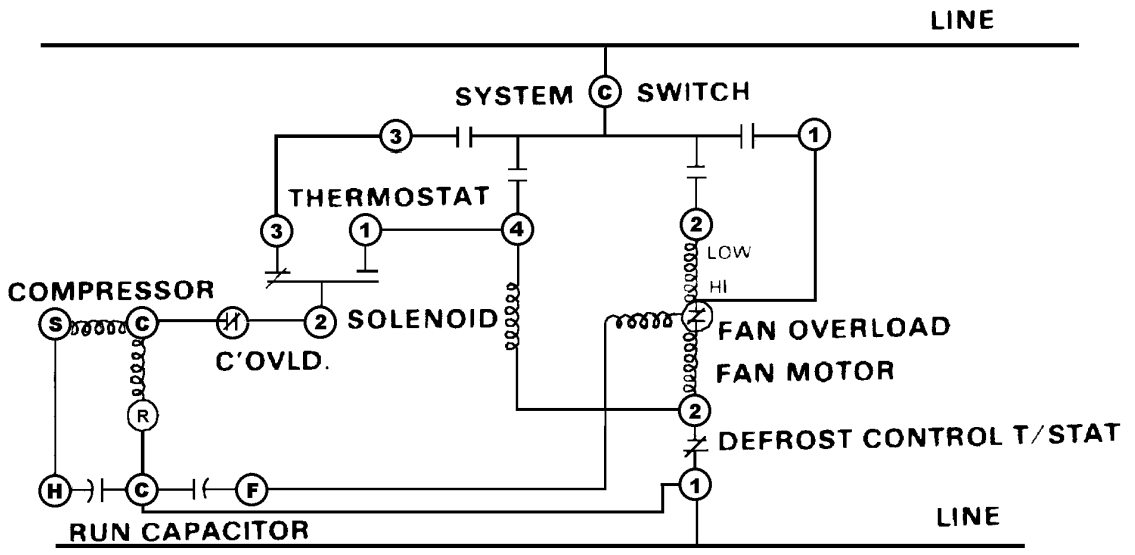

617-581-05

WIRING DIAGRAM FOR MODEL SC06H10D

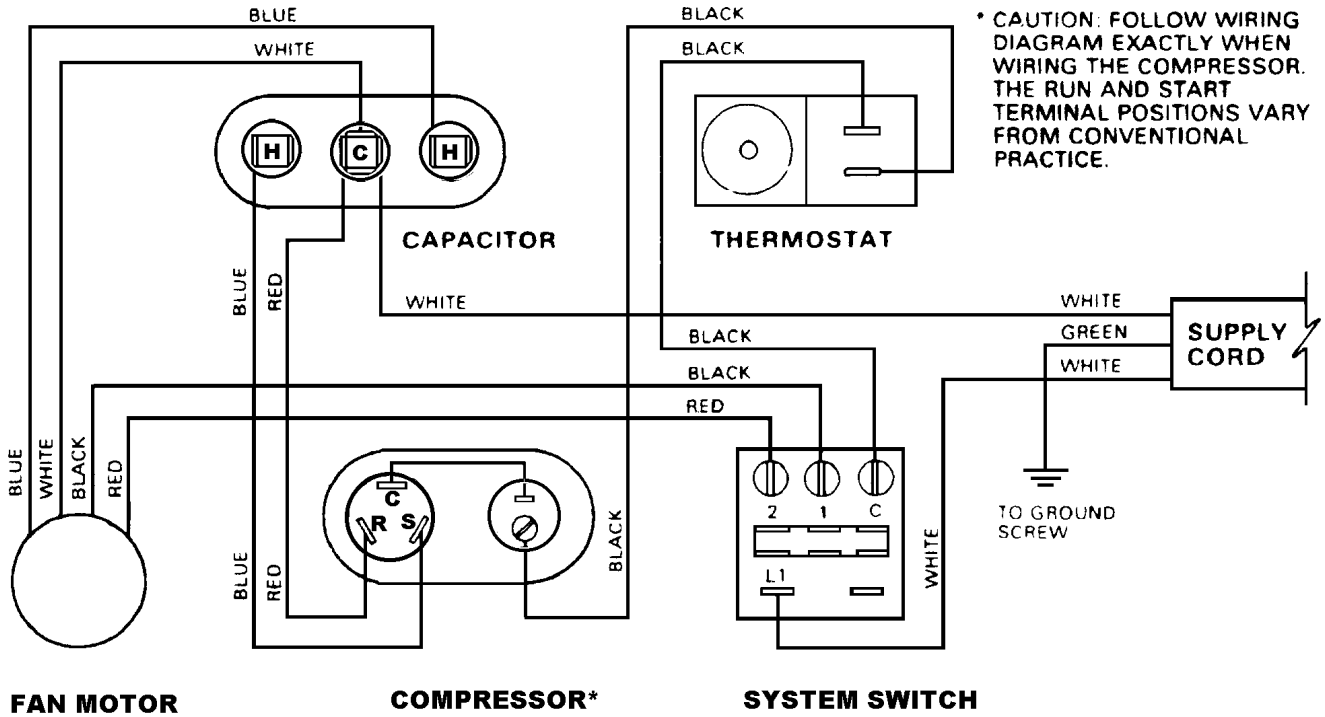

SCHEMATIC

SYSTEM SWITCH SEQUENCE			
	CLOSED CONTACTS		
OFF	HI-COOL	LO-COOL	HI-FAN
ALL OPEN	L1-1 L1-C	L1-2 L1-C	L1-1

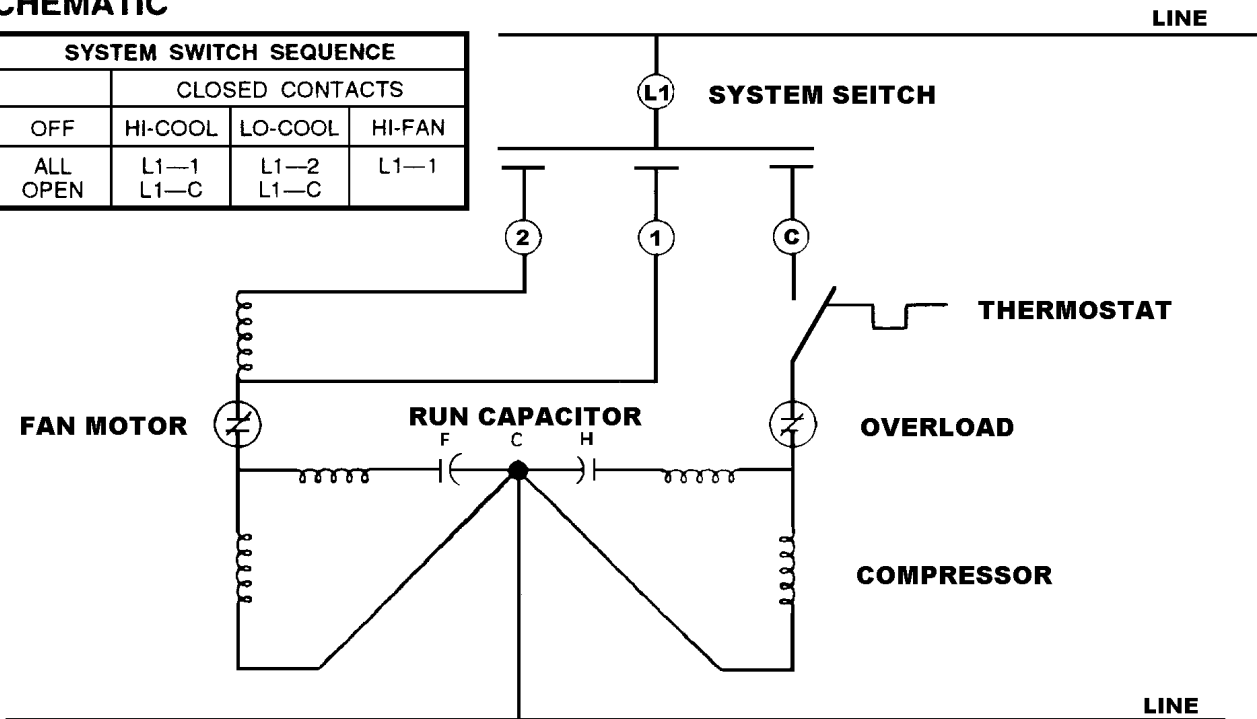

614-406-00

WIRING DIAGRAM FOR MODELS

**SS08J10A-1, SS08J10R-1, SS09J10A-1, SS10J10A-1, SS10J10R-1,
SS12J10A-1, SS12J30A-1, SS12J30A-3, SS12J10R-3, SS12J10R-2, SS15J30A-
1, SM14J10B-1, SM18J30A-2, SM18J30A-3, & SM21J30A-4**

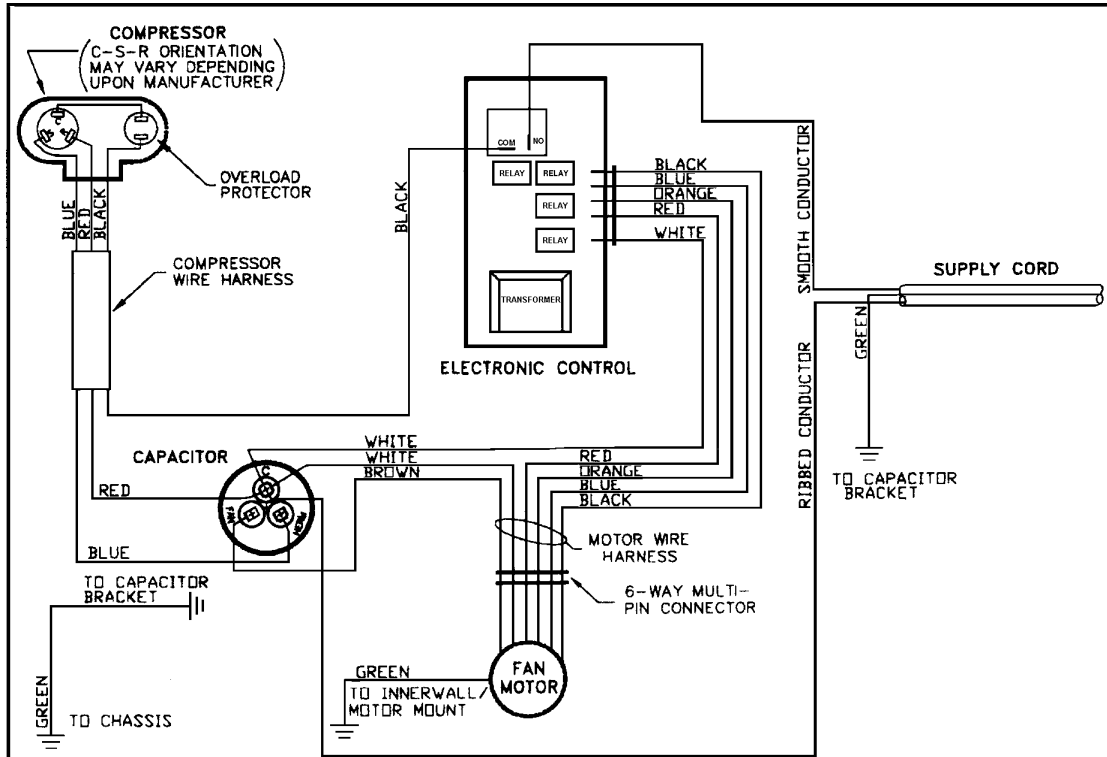

SCHEMATIC

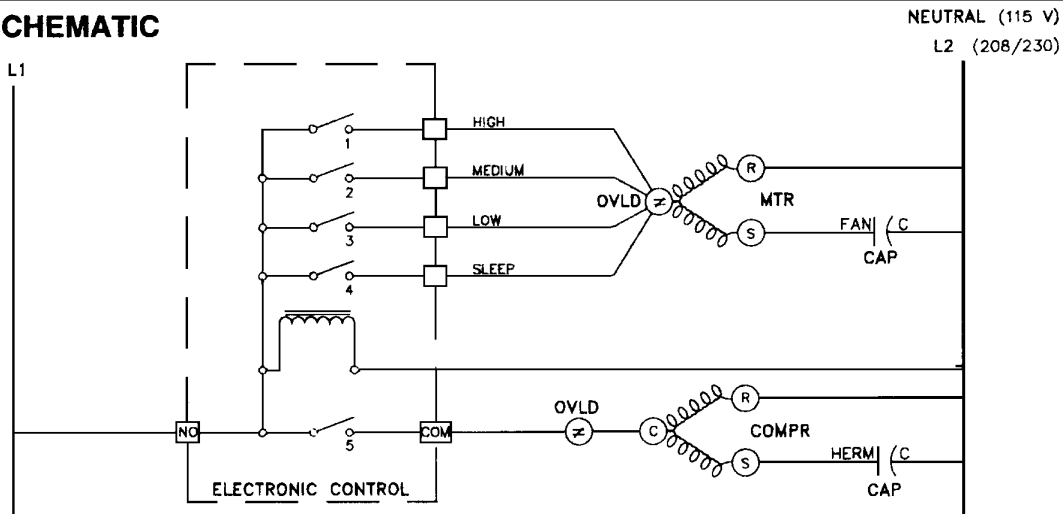

SWITCH LOGIC X = CLOSED
O = OPEN

SWITCH POSITION	CIRCUIT				
	1	2	3	4	5
OFF	O	O	O	O	O
HI COOL	X	O	O	O	X
MED COOL	O	X	O	O	X
LOW COOL	O	O	X	O	X
SLEEP	O	O	O	X	X

LEGEND

CAP - CAPACITOR
 COMPR - COMPRESSOR
 MTR - FAN MOTOR
 OVLD - OVERLOAD PROTECTOR

● - COMBINATION TERMINAL
 —||— - GROUND LEAD

PART NO. 618-200-03 REV.

WIRING DIAGRAM FOR MODELS: SL24J30A-1, SL24J30A-3, SL28J30A-1, & SL33J30-2

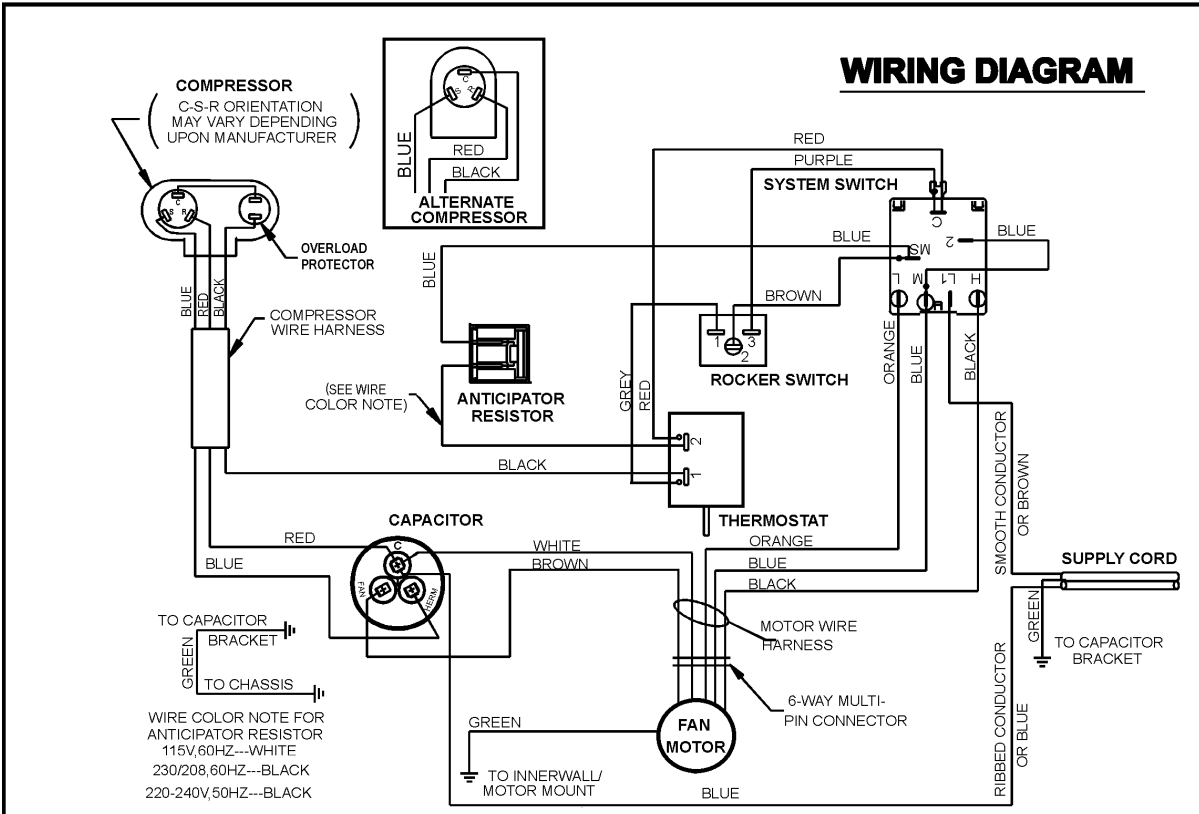

SCHEMATIC

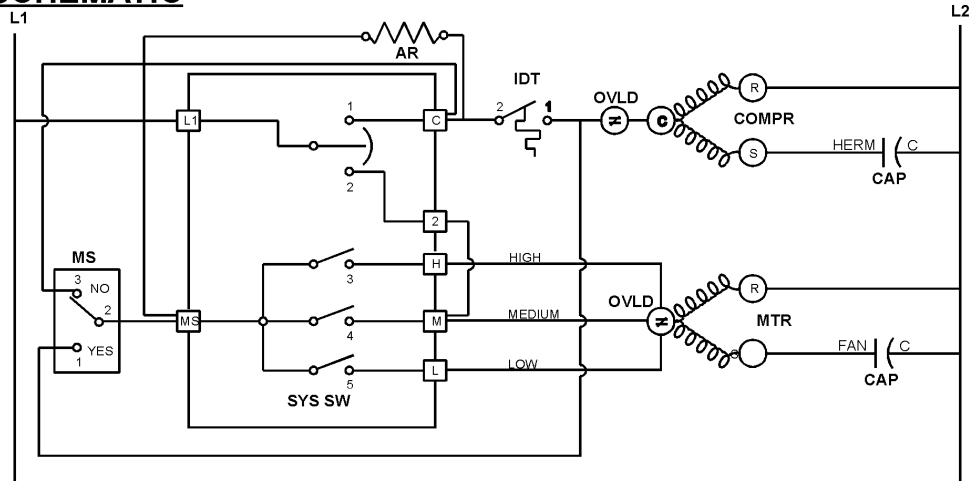

SWITCH LOGIC

X = CLOSED
O = OPEN

SWITCH POSITION	1	2	3	4	5
OFF	O	O	O	O	O
LOW COOL	X	O	O	O	X
MED COOL	X	O	O	X	O
HI COOL	X	O	X	O	O
FAN ONLY	O	X	O	O	O

LEGEND

AR - ANTICIPATOR RESISTOR
MS - MONEY SAVER/ROCKER SWITCH
CAP - CAPACITOR
COMPR - COMPRESSOR
MTR - FAN MOTOR
OVLDT - OVERLOAD PROTECTOR
SYS SW - SYSTEM SWITCH
IDT - INDOOR THERMOSTAT

- GROUND LEAD
 - COMBINATION TERMINAL
 - PLASTIC INSULATOR

PART NO. 618-200-00
REV. 02

Wiring Diagram for "KS," "KM" & "KL" Models

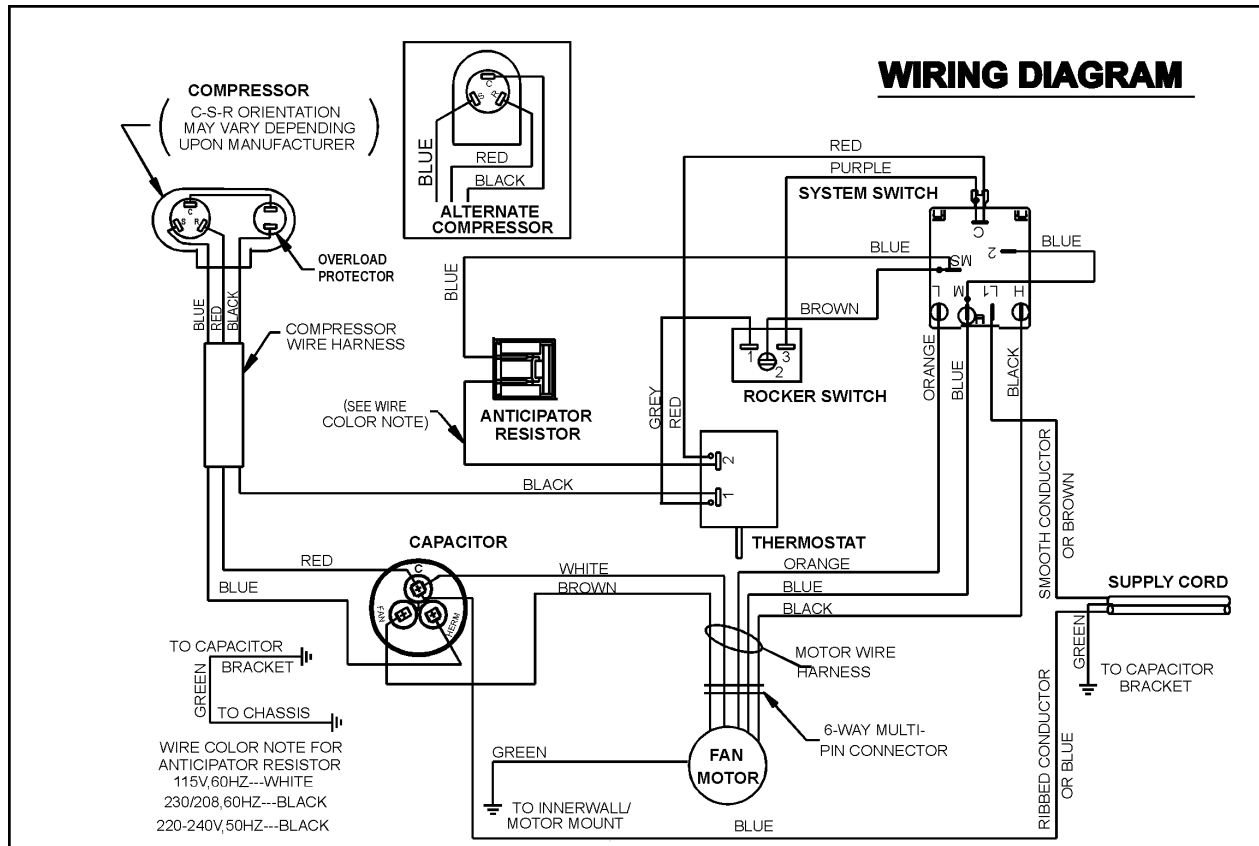

SCHEMATIC

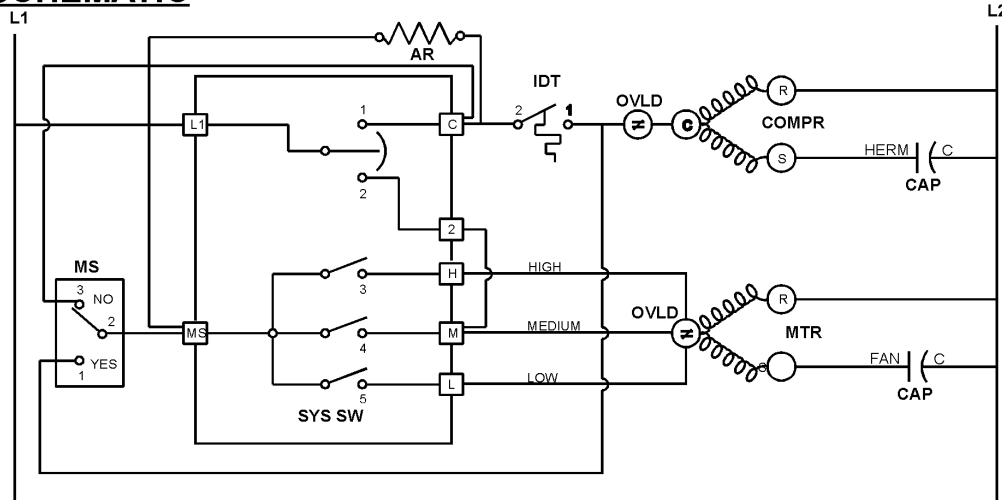

SWITCH LOGIC

SWITCH POSITION	CIRCUIT				
	1	2	3	4	5
OFF	O	O	O	O	O
LOW COOL	X	O	O	O	X
MED COOL	X	O	X	O	O
HI COOL	X	O	X	X	O
FAN ONLY	O	X	O	O	O

X = CLOSED
O = OPEN

LEGEND

- AR - ANTICIPATOR RESISTOR
- MS - MONEY SAVER/ROCKER SWITCH
- CAP - CAPACITOR
- COMP - COMPRESSOR
- MTR - FAN MOTOR
- OVLD - OVERLOAD PROTECTOR
- SYS SW - SYSTEM SWITCH
- IDT - INDOOR THERMOSTAT

- GROUND LEAD
- COMBINATION TERMINAL
- PLASTIC INSULATOR

PART NO.
618-200-00

REV.
02

WIRING DIAGRAM FOR MODELS ES12J33, ES15J33A, EM18J34A EL24J35, EL33J35, EK12J33A, EK18J34A-2 & EK18J34A-3

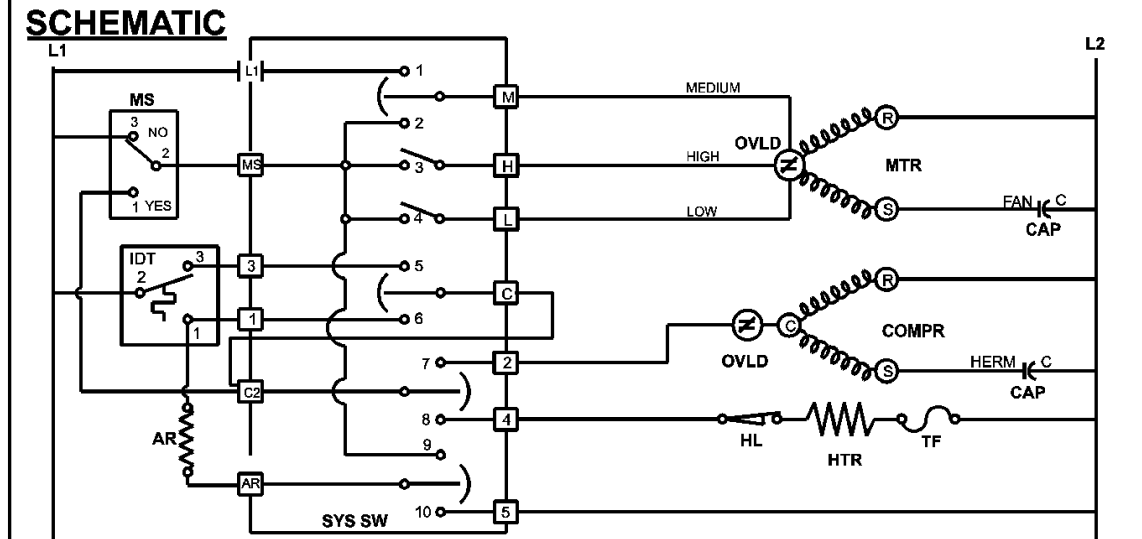
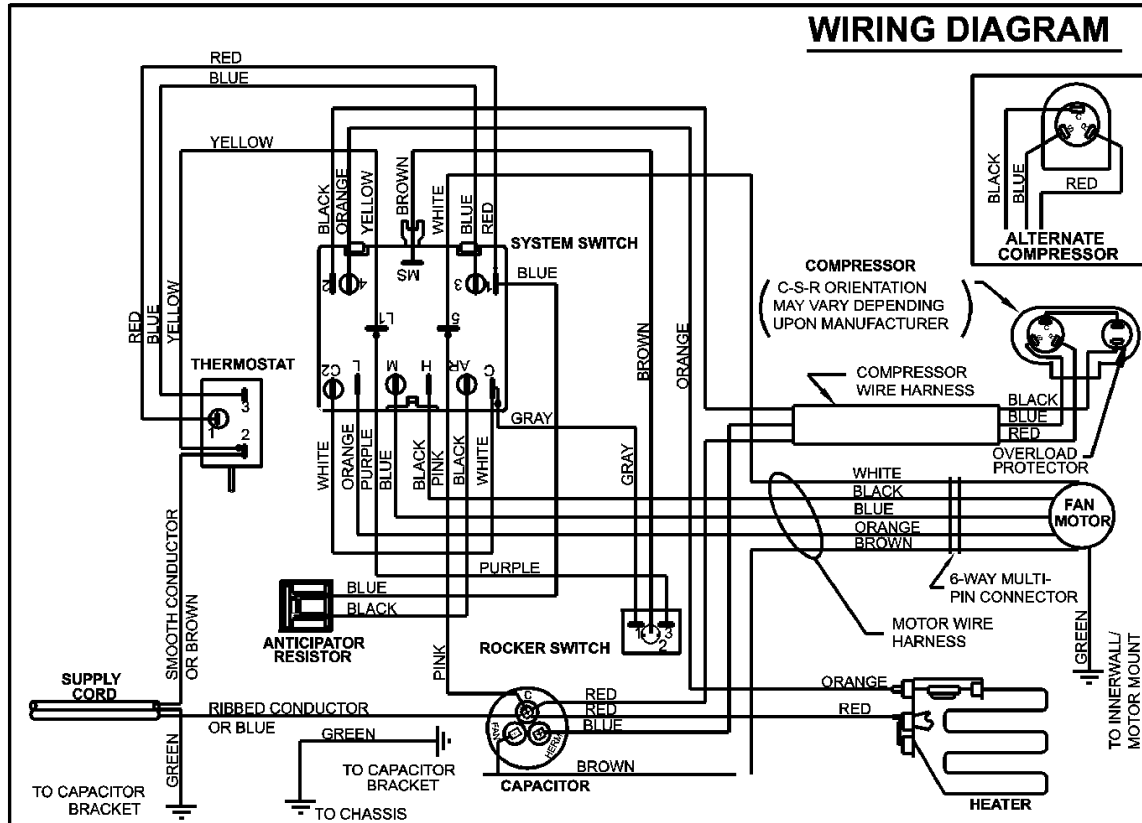

SWITCH LOGIC		LEGEND	
SWITCH POSITION	CIRCUIT	AR	HTR
OFF	0 0 0 0 0 0 0 0 0 0	MS - MONEY SAVER/ROCKER SWITCH	HL - HEATER LIMIT
LOW COOL	0 0 0 X X 0 X 0 X 0	CAP - CAPACITOR	TF - THERMAL FUSE
MEDIUM COOL	0 X 0 0 X 0 X 0 X 0	COMPR - COMPRESSOR	- GROUND LEAD
HIGH COOL	0 0 0 X 0 X 0 X 0 X 0	MTR - FAN MOTOR	- COMBINATION TERMINAL
HIGH HEAT	0 0 X 0 0 X 0 X 0 X	OVL D - OVERLOAD PROTECTOR	○ - PLASTIC INSULATOR
MEDIUM HEAT	0 X 0 0 0 X 0 X 0 X	SYS SW - SYSTEM SWITCH	
LOW HEAT	0 0 0 X 0 X 0 X 0 X	IDT - INDOOR THERMOSTAT	
FAN ONLY	X 0 0 0 0 0 0 0 0 0		

AR - ANTICIPATOR RESISTOR

MS - MONEY SAVER/ROCKER SWITCH

CAP - CAPACITOR

COMPR - COMPRESSOR

MTR - FAN MOTOR

OVL D - OVERLOAD PROTECTOR

SYS SW - SYSTEM SWITCH

IDT - INDOOR THERMOSTAT

HTR - HEATER

HL - HEATER LIMIT

TF - THERMAL FUSE

- GROUND LEAD

- COMBINATION TERMINAL

○ - PLASTIC INSULATOR

PART NO. 618-200-01	REV. 02
------------------------	------------

WIRING DIAGRAM FOR MODEL YS09J10A

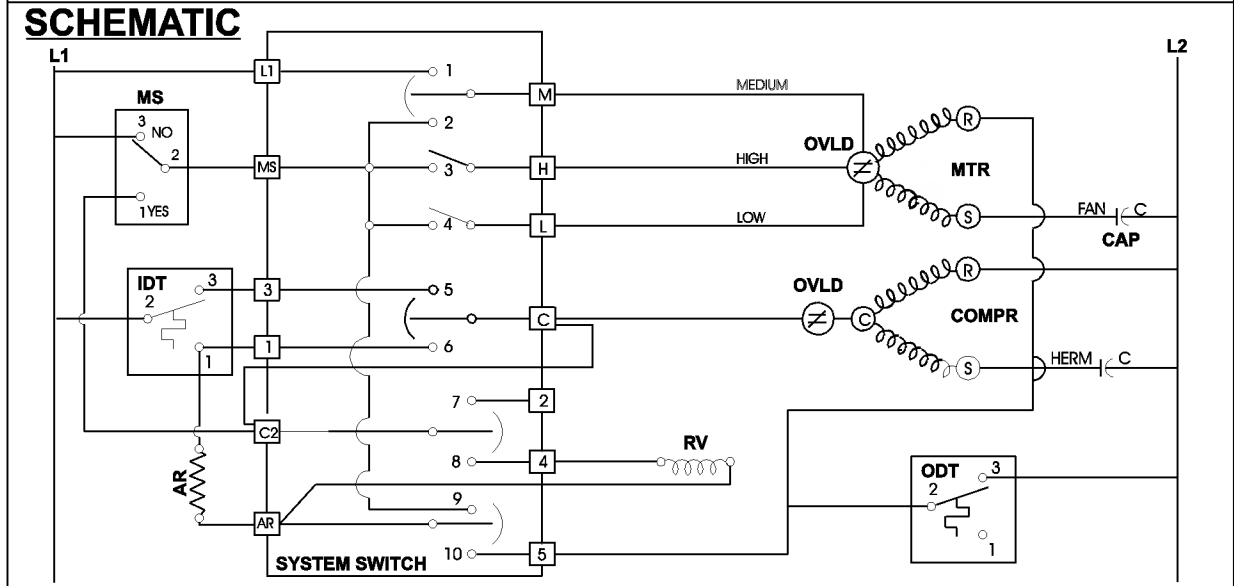
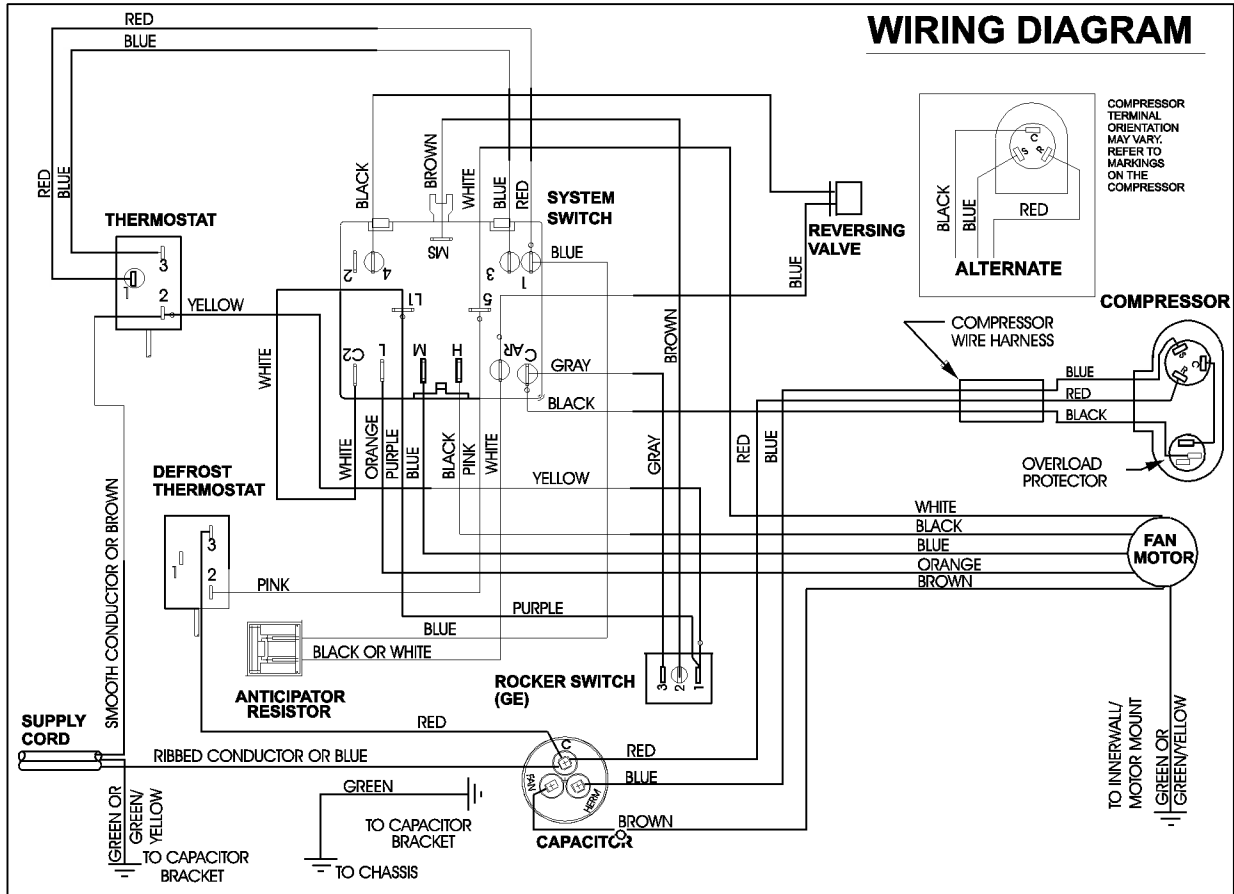

SWITCH LOGIC

X = CLOSED
 0 = OPEN

SWITCH POSITION	1	2	3	4	5	6	7	8	9	10
OFF	0	0	0	0	0	0	0	0	0	0
LOW COOL	0	0	0	0	0	0	0	0	0	0
MEDIUM COOL	0	0	0	0	0	0	0	0	0	0
HIGH COOL	0	0	0	0	0	0	0	0	0	0
HIGH HEAT	0	0	0	0	0	0	0	0	0	0
MEDIUM HEAT	0	0	0	0	0	0	0	0	0	0
LOW HEAT	0	0	0	0	0	0	0	0	0	0
FAN ONLY	X	0	0	0	0	0	0	0	0	0

LEGEND

- AR - ANTICIPATOR RESISTOR
- MS - MONEY SAVER
- CAP - CAPACITOR
- COMPR - COMPRESSOR
- MTR - FAN MOTOR
- OVLD - OVERLOAD PROTECTOR
- RV - REVERSING VALVE
- IDT - INDOOR THERMOSTAT
- ODT - OUTDOOR THERMOSTAT

- GROUND LEAD
 - COMBINATION TERMINAL
 - PLASTIC INSULATOR

PART NO. 619-142-17
 REV. 00

TESTING THE ELECTRONIC CONTROL 2001 XQ BOARDS & QME BOARDS

Checking Room Temperature:

1. Check the room temperature at the electronic control pad by pressing at the same time the "**FAN SPEED**" button and the temperature "**UP**" button on **XQ models**.
2. Check the room temperature at the electronic control pad by pressing at the same time the "**FAN SPEED**" button and the "**WARMER**" button on **QME models**. The indoor temperature will display for 10 seconds. Indoor temperature can be viewed in all modes, including the TEST mode. The display can be changed back to SET temperature by pressing any key, except the ON/OFF button, or after 10 seconds has elapsed.

Activating Test Mode: Activate test mode by pressing at the same time the "**MODE**" button and the temperature "**DOWN**" button on **XQ models**. LEDs for Hour, Start, and Stop will blink 1 bps while Test Mode is active. Activate test mode by pressing at the same time the "**MONEY SAVER**" button and the "**FILTER ALERT**" button on **QME models**. LED for the Filter Alert will blink 1 bps while Test Mode is active.

Test Mode has duration of 90 minutes. Test Mode can be activated under any conditions, including Off. Test Mode is cancelled by pressing the On/Off button, unplugging the unit, or when the 90 minutes is timed out. All settings revert to the factory default settings of Cool, 75 degrees F, Timer and Set Hour features are nonfunctional.

Test Mode overrides the three-minute lockout, all delays for compressor and fan motor start / speed change, and no delay when switching modes. Test Mode default settings are ON, Money Saver, 60 degrees F, and High fan speed.

Activating Error Code Mode: (Submode of Test Mode) Unit has to be in Test Mode to enter Error Code Mode

1. Activate Error Code Mode by pressing the "**TIMER ON/OFF**" button on XQ models. LED for the "**TIMER ON/OFF**" will flash 1 bps while Error Code Mode is active. Pressing the "**TEMP/HR +**" button will display 00. Consecutive presses will scroll through all error codes logged. Press the "**TEMP/HR -**" button to see the reverse order of all error codes logged. When the end of logged error codes is reached the temperature set point will appear.

Activate Error Code Mode by pressing at the same time the "**A/C START**" button and the "**ON/OFF**" button on QME models. LED for the "**TIMER ON/OFF**" will flash 1 bps while Error Code Mode is active. Pressing the "**WARMER**" button will display 00. Consecutive presses will scroll through all error codes logged. Press the "**COOLER**" button to see the reverse order of all error codes logged. When the end of logged error codes is reached the temperature set point will appear.

IMPORTANT

Error Codes are cleared from the log by exiting from Error Code Mode. To exit on XQ models, press Timer On/Off button. To exit QME models, press A/C Start and On/Off buttons. Or unplug unit to exit Error Code Mode. Plug unit in after 5 seconds to resume normal operation of unit.

QUICK REFERENCE GUIDE

QuietMaster® Electronic Room Air Conditioner

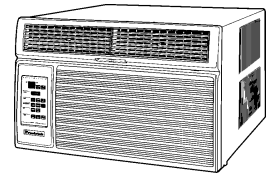

TOUCH

TO START UNIT

Touch the **ON/OFF** button. The unit will automatically be in regular COOLING mode with the temperature set at 75°F (24°C) and the fan speed at F1 (SLEEP).

NOTE: Should the **FILTER ALERT** light flash when you first turn the unit on, touch the **FILTER ALERT** button to turn off the flashing light.

ON / OFF

TO ADJUST TEMPERATURE

COOLER – Touch **COOLER** and hold until the display shows the desired room temperature.

WARMER – Touch **WARMER** and hold until the display shows the desired room temperature.

FAHRENHEIT / CELSIUS – Touch **°F / °C** to show the temperature in Celsius, touch again to show Fahrenheit.

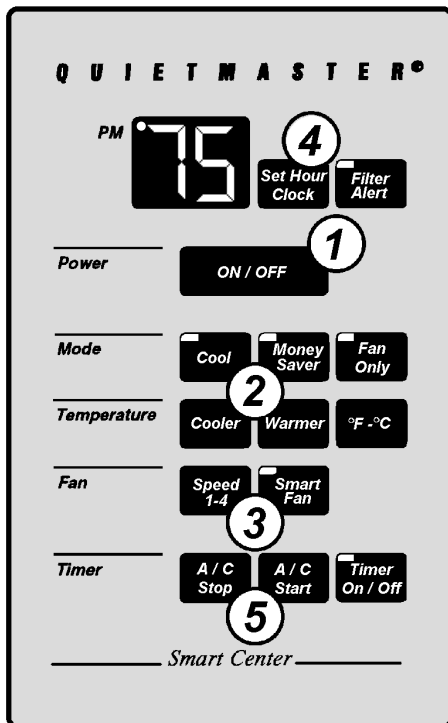

Smart Center®
ELECTRONIC CONTROLS

TO ADJUST THE FAN SPEED

Touch **SPEED 1-4** until the display shows the desired fan speed. **F1** is the lowest setting (SLEEP SETTING), **F2** is LOW, **F3** is MEDIUM, **F4** is HIGH. Touch **SMART FAN** (light on) and the fan speed will adjust automatically to maintain the desired comfort level.

Touch **SPEED 1-4** for manual control of fan speeds



TO SET THE CLOCK TIME

Touch **SET HOUR CLOCK** and hold until the hour closest to the actual time appears in the display. Make sure you set A.M. and P.M. properly. Minutes will NOT show on the display.



TO SET THE TIMER

STOP TIME – Touch **A/C STOP** and hold until the hour you want the unit to shut off appears in the display.

START TIME – Touch **A/C START** and hold until the hour you want the unit to come on appears in the display.

Touch **TIMER ON** (light on) to activate the timer function. Touch **TIMER OFF** (light off) to cancel the timer function. Once the on and off times have been selected, they will remain in memory. However, if the power is interrupted, set the **CLOCK TIME** again.

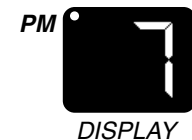

• For complete operating instructions refer to the Operating Guide.

QUICK REFERENCE GUIDE

XSTAR® Room Air Conditioner

TOUCH

~ TO START UNIT

Touch the **POWER ON/OFF** button. The unit will automatically be in regular COOLING mode with the temperature set at 75°F (24°C) and the fan speed at F1 (SLEEP).

POWER
On/Off

TM TO ADJUST TEMPERATURE

COOLER – Touch  and hold until the display shows the desired room temperature.

WARMER – Touch  and hold until the display shows the desired room temperature.

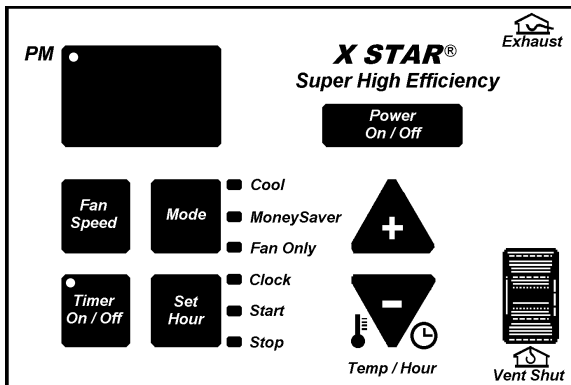
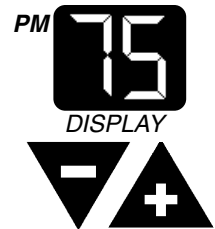

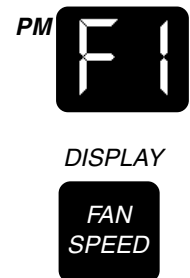

§ TO ADJUST THE FAN SPEED

Touch **FAN SPEED** until the display shows the desired fan speed. **F1** is the lowest setting (SLEEP SETTING / LOW), **F2** is MED, **F3** is HIGH, and **SF** is **SMART FAN**. With SMART FAN on, the fan speed will adjust automatically to maintain the desired comfort level.





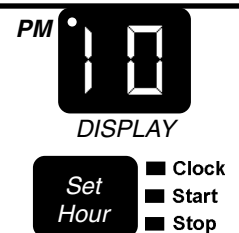

> TO SET THE CLOCK TIME

Touch **SET HOUR** (Clock light On), then press  or  until the hour closest to the actual time appears in the display. Make sure you set A.M. and P.M. properly. Minutes will NOT show on the display.



œ TO SET THE TIMER

START TIME – After the clock time has been set, press **SET HOUR** (START light on) then press  and  until the hour you want the unit to come on appears in the display.

STOP TIME – After the start time has been set, press **SET HOUR** (STOP light on), then press  and  until the hour you want the unit to shut off appears in the display.

Touch **TIMER ON** (light on) to activate the timer function. Touch **TIMER OFF** (light off) to cancel the timer function. Once the on and off times have been selected, they will remain in memory. However, if the power is interrupted, set the CLOCK TIME again.

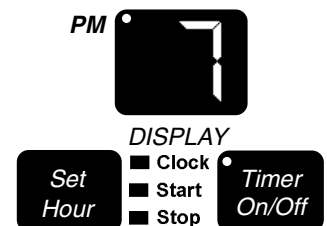

● For complete operating instructions refer to the Operating Guide.



FRIEDRICH AIR CONDITIONING CO.

- Post Office Box 1540 • San Antonio, Texas 78295-1540
 - 4200 N. Pan Am Expressway • San Antonio, Texas 78218-5212
 - (210) 357-4400 • FAX (210) 357-4480
- Visit us on the Internet at www.friedrich.com

Printed in the U.S.A.

RACServMn (01/02)