

# Service Manual Trucks

Group **72**

Volvo Air Suspension

VNL, VNM

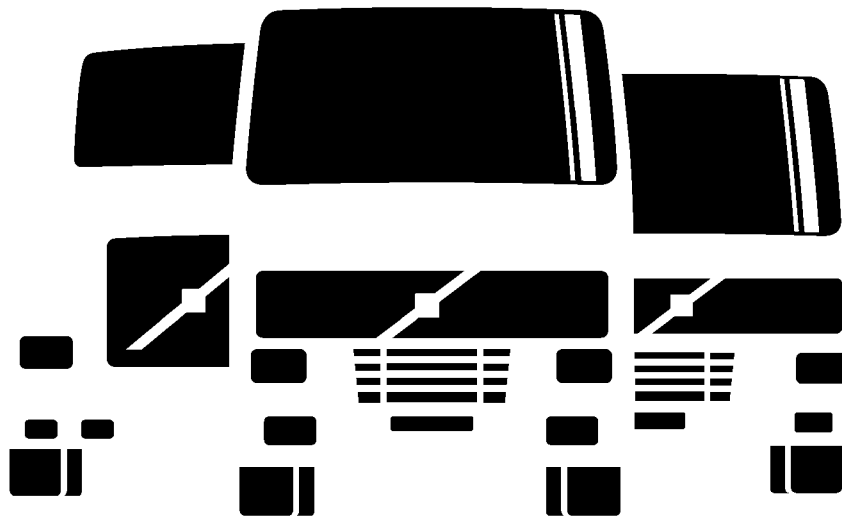

# Foreword

The descriptions and service procedures contained in this manual are based on designs and methods studies carried out up to November 97.

The products are under continuous development. Vehicles and components produced after the above date may therefore have different specifications and repair methods. When this is believed to have a significant bearing on this manual, supplementary service bulletins will be issued to cover the changes.

The new edition of this manual will update the changes.

In service procedures where the title incorporates an operation number, this is a reference to an S.R.T. (Standard Repair Time).

Service procedures which do not include an operation number in the title are for general information and no reference is made to an S.R.T.

The following levels of observations, cautions and warnings are used in this Service Documentation:

**Note:** Indicates a procedure, practice, or condition that must be followed in order to have the vehicle or component function in the manner intended.

**Caution:** Indicates an unsafe practice where damage to the product could occur.

**Warning:** Indicates an unsafe practice where personal injury or severe damage to the product could occur.

**Danger:** Indicates an unsafe practice where serious personal injury or death could occur.

**Volvo Trucks North America, Inc.**  
Greensboro, NC USA

**Order number: PV776-TSP27725/1**

© 97 Volvo Trucks North America, Inc., Greensboro, NC USA

All rights reserved. No part of this publication may be reproduced, stored in retrieval system, or transmitted in any forms by any means, electronic, mechanical, photocopying, recording or otherwise, without the prior written permission of Volvo Trucks North America, Inc..

# Contents

<b>General</b> .....	3
Description .....	3
<b>Specifications</b> .....	5
Rear suspension (Air Ride) fastener torque specifications .....	5
Pinion angle specifications .....	5
Suspension Applications .....	6
<b>Tools</b> .....	7
Special Tools .....	7
Other Equipment .....	7
<b>Design and Function</b> .....	9
General .....	9
Volvo Air Suspension Components .....	10
Spring Bracket .....	10
Wear Plate .....	10
Z-Spring .....	10
Radius Spring .....	10
Crossbeam .....	11
Axle Seat .....	11
Bottom Plate .....	11
Top Plate .....	11
Air Spring .....	12
Link Rod .....	12
Leveling/Height Valve .....	12
Shock Absorber Bracket, Lower .....	13
Shock Absorber Bracket, Upper .....	13
Torque Rod .....	13
Pneumatic Switch Panel .....	14
Dump Switch Operation .....	15
<b>Troubleshooting</b> .....	17
Troubleshooting the Volvo Air Suspension .....	17
<b>Service Procedures</b> .....	19
Guidelines for Working on the Volvo Air Suspension .....	19
Volvo Air Suspension Ride Height and Driveline Angle Check (Calculation) and Adjustment .....	20
Air Suspension Ride Height Check (Calculation) .....	21
Interaxle U-joint Angle Cancellation Check (Calculation) .....	22
Forward Axle Pinion Angle to Frame Check .....	24
U-bolt Torque Procedure .....	25
Method 1 (preferred) .....	25
Method 2 .....	25
Volvo Air Suspension Ride Height Adjustment .....	26
Volvo Air Suspension Component Replacement .....	28
Leveling Valve Replacement .....	28
Link Rod Replacement .....	29
Crossbeam (Pedestal Plate) Replacement .....	31
Z-Spring Replacement .....	32
Radius Spring Replacement .....	34
Torque Rod and Frame Bracket Replacement .....	36
Spring Hanger (Frame) Bracket Replacement .....	37
Wear Plate (Pad) Replacement .....	38
Upper Shock Absorber Bracket Removal and Installation .....	40

Lower Shock Absorber Bracket Removal and Installation .....	40
Shock Absorber Removal and Installation .....	42
Rear Axle Top Plate/Bottom Plate Removal and Installation .....	42
Air Spring Removal and Installation .....	44
Pneumatic switch replacement .....	45
Removal .....	45
Installation .....	45
<b>System Check</b> .....	47
Volvo Air Suspension .....	47
Volvo Air Suspension Ride Height and Driveline Angle Check Flow Diagram .....	48
Volvo Air Suspension — Calculation Form .....	49
<b>Operation Numbers</b>	

# General

## Description

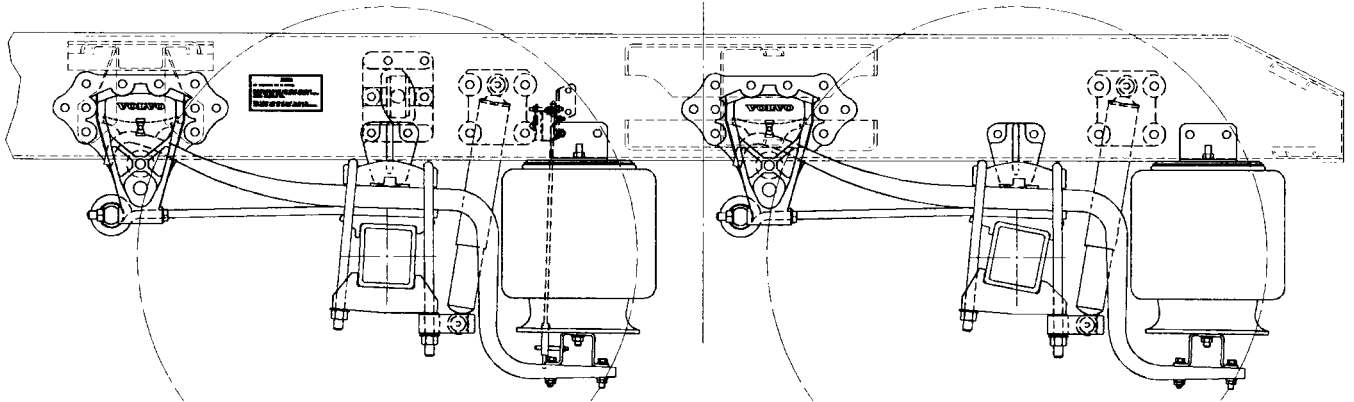

W7000753

This information covers specifications, service procedures, ride height adjustments and calculations, and pinion angles for the Volvo Air Suspension. Information in this manual is essential to maintain proper serviceability and proper ride height set by the manufacturer for the Volvo Air Suspension.



### WARNING

The Volvo Air Suspension is set at the factory. Changing the ride height will affect the driveshaft angles and may cause driveline vibration and/or shorten component life.

**Ride height adjustments must be performed in accordance with all service manual procedures.**



## Specifications

### Rear suspension (Air Ride) fastener torque specifications

U-Bolts for Suspension	M20	STD 38K 6x4 500 ± 75 Nm (369 ± 55 ft-lb)
	M22	STD 40K 6x4, 4x2 575 ± 50 Nm (424 ± 37 ft-lb)
Radius Spring to Spring Hanger Bracket	M16	275 ± 45 Nm (203 ± 33 ft-lb)
Air Spring Crossbeam (Pedestal) to Leaf Spring	M12	105 ± 20 Nm (77 ± 15 ft-lb)
Air Spring to Crossbeam (Pedestal)	M12	50 ± 10 Nm (37 ± 7.5 ft-lb)
Torque Rod to Frame-Mounted Bracket	M16	320 ± 50 Nm (236 ± 37 ft-lb)
Torque Rod to Axle Housing	M16	320 ± 50 Nm (236 ± 37 ft-lb)
Shock Absorber Bracket to Frame	M16	320 ± 50 Nm (236 ± 37 ft-lb)
Shock Absorber to Bracket (Upper and Lower)	M10	60 ± 10 Nm (44 ± 7 ft-lb)
Bracket for Leveling Valve to Frame	M10	60 ± 10 Nm (44 ± 7 ft-lb)
Leveling Valve to Bracket	M6	10 ± 1.5 Nm (7 ± 1 ft-lb)
Leveling Valve Control Arm to Lever on Valve and Air Bag Pedestal	M6	10 ± 1.5 Nm (7 ± 1 ft-lb)
Spring Hanger Bracket to Frame	M16	320 ± 50 Nm (236 ± 37 ft-lb)

### Pinion angle specifications

AXLE PINION ANGLES			
AXLE MODEL	FIRST AXLE	SECOND AXLE (52 in. spacing)	SECOND AXLE (60 in. spacing)
<b>Eaton</b> 23080/23105 <b>Meritor (Rockwell)</b> RS-23-160/RS-23-186	3.5°	---	---
<b>Eaton</b> D404	2.5°	10.5°	9.0°
<b>Meritor (Rockwell)</b> RT-40-145	2.5°	12.0°	10.5°

**Note:** Second tandem axle pinion angle may vary because of frame slope. *These are nominal angles.*

## Suspension Applications

Suspension Configuration	Maximum GAWR Metric Ton (lb)	Maximum GCW Metric Ton (lb)	Axle Spacing mm (in.)	Required Number of Parking Chambers	Available Axles	
					Models	Metric Ton (lb)
4x2	9 (20,000) <b>(1)</b>	50 (110,000) <b>(2)</b>	N/A	TWO	Eaton Meritor (Rock- well)	10 (23,000)
6x4	17 (38,000)		1320 (52")	TWO (1st Axle)	Eaton Meritor (Rock- well)	18 (40,000)
	18 (40,000) <b>(1)</b>		1320 (52")	FOUR		
	18 (40,000) <b>(1)</b>		1524 (60")	FOUR		

(1) All 6x4 applications at 18 metric ton (40,000 lb) and all 4x2 applications require 22mm diameter U-bolts as standard. Also, 6x4 applications at 18 metric ton (40,000 lb) require heavy wall axle housings. All 6x4 vehicles delivered outside the United States require 22mm U-bolts (minimum) and the heavy wall axle housing (minimum) regardless of the suspension rating.

(2) GCW (Gross Combination Weight) rating can be reduced by vehicle operating applications, engine horsepower/torque, axle type/model, axle ratio, and/or vehicle tire size.



## Tools

### Special Tools

This air line release tool, part no. J-42189 may be used to safely disconnect air lines from switches. This tool is available from Kent-Moore (telephone: 1-800-328-6657).

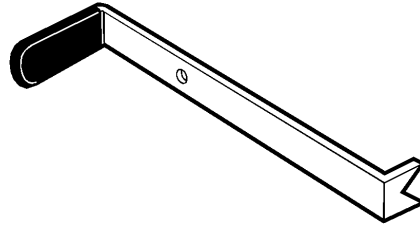

W0001198

### Other Equipment

The following tools can be used to ensure proper inclinations and/or angles on the Volvo Air Suspension:

The Anglemaster is a digital inclinometer, available from Dana-Spicer (telephone: 419-535-4300).

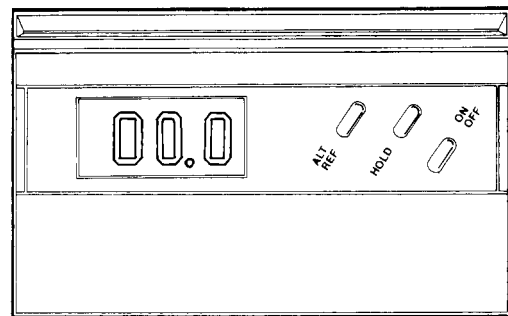

W7000250

The J38460-A is a digital protractor, available from Kent-Moore (telephone: 800-328-6657).

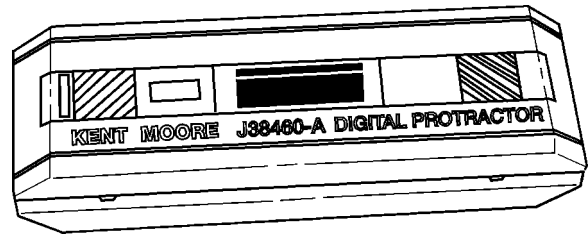

W7000708

The J38460-25 may be used along with the Kent-Moore digital protractor or the Dana-Spicer digital inclinometer for checking pinion angles. It is available from Kent-Moore (telephone: 800-328-6657).

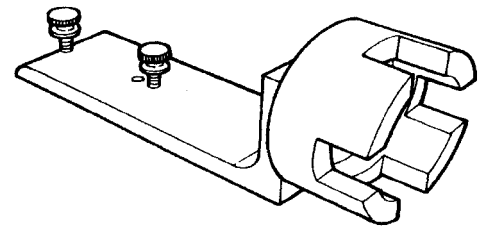

W7000726



# Design and Function

## General

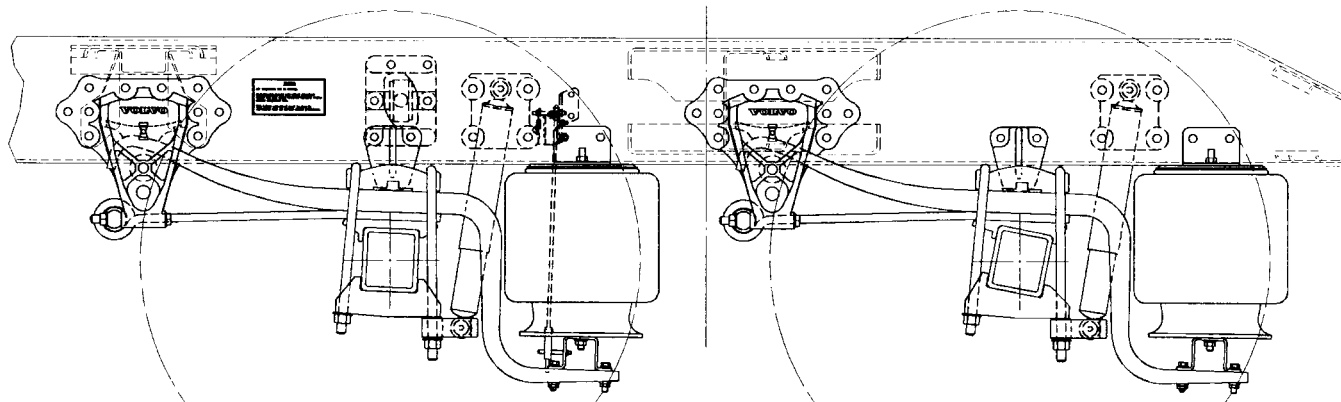

W7000753

The Air-Ride Suspension has been refined by Volvo Trucks North America. The result of this refinement process is the Volvo Air Suspension. The Volvo Air Suspension is a rear air suspension with improved ride and increased durability.

Ride height has a direct relationship with driveline pinion angles. It is very important that the ride height specifications recommended by Volvo Trucks North America are maintained.



### WARNING

The Volvo Air Suspension is set at the factory. Changing the ride height will affect the driveshaft angles and may cause driveline vibration and/or shorten component life.

**Ride height adjustments must be performed in accordance with all service manual procedures.**

# Volvo Air Suspension Components

## Spring Bracket

The Volvo Air Suspension bracket is a ductile iron casting and includes an internal alignment guide to help center the Z-spring within the bracket during initial assembly.

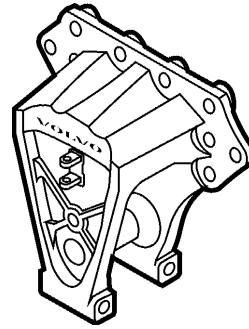

W7000695

## Wear Plate

The wear plate (pad) is constructed of the same material (Ultra-High Molecular Weight Polyethylene) as earlier wear plates. This material provides an extremely smooth surface for the spring to contact and virtually eliminates the noise associated with the metal-to-metal contact of other suspension designs. The Volvo Air Suspension wear plate mounts with a single fastener into a pocket between the vertical legs of the spring bracket.

**Note:** Wear plates (pads) must be replaced in pairs (left and right) to avoid excessive stress on the suspension.

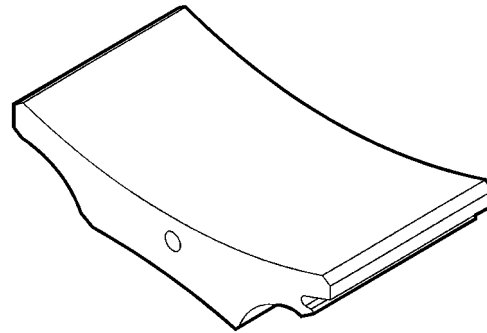

W7000739

## Z-Spring

The Z-spring has been improved to provide a larger clamping surface, an improved alignment with mating components, and increased clearance to the lower shock mounting bracket.

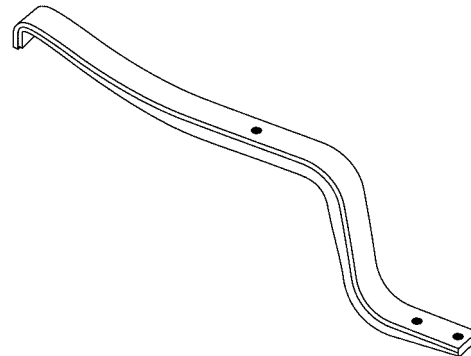

W7000219

## Radius Spring

The radius spring is crucial to the vehicle's alignment. The radius spring has an improved bushing for increased component durability. The Volvo Air Suspension spring uses a locating pin that precisely locates the radius spring for an improved fit with the mating Z-spring and axle seat. Precisely locating the radius spring helps to improve the vehicles overall axle alignment.

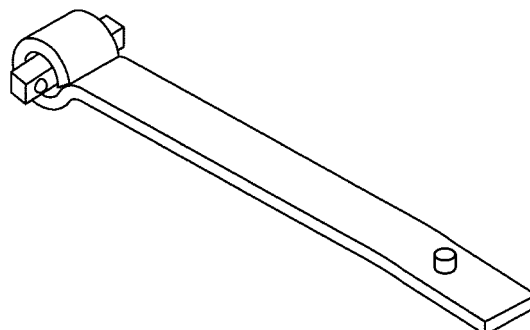

W7000761

## Crossbeam

The crossbeam (pedestal plate) has been greatly refined to improve strength while reducing weight. The Volvo Air Suspension crossbeam uses only four mounting bolts (two on each end) for easy installation of the Z-spring.



W7000704

Crossbeam

## Axle Seat

The axle seat defines the axle pinion inclination. It has been refined to eliminate the extra spacers necessary in earlier designs. By eliminating the spacers, the Volvo Air Suspension axle seat forms a strong, secure joint between the radius spring and the axle.

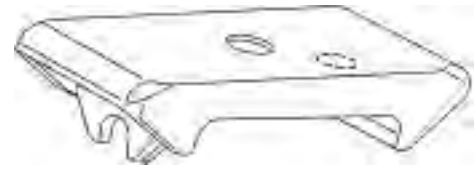

W7000727

Axle seat

## Bottom Plate

The bottom axle plate is found underneath the axle housing, and is held in place by U-bolts. It helps maintain axle alignment with the springs in the suspension and prevents movement of the axle. It can also be helpful in keeping U-bolts properly aligned and secured.

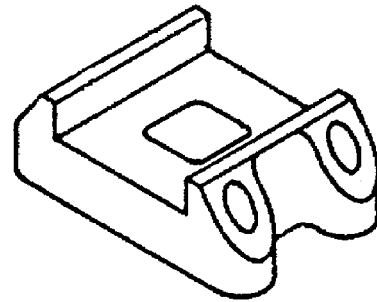

W7000721

Bottom plate

## Top Plate

The top plate (upper clip) is located at the top of the Z-spring and is clamped down by the U-bolts. It is helpful in maintaining alignment of the U-bolts to secure and align the Z-spring, radius spring, and axle seats. The top plate also helps maintain a secure surface for U-bolts when torqued.

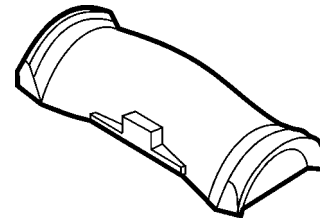

W7000712

Top plate

## Air Spring

The air spring in the Volvo Air Suspension system is a rolling-lobe, sleeve type with a composite piston. The air spring uses a single stud to attach to the crossbeam.



### CAUTION

Do not mix the air springs of the Volvo Air Suspension with air springs of earlier suspensions. System failure may result.

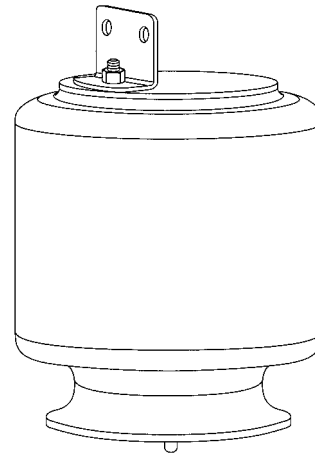

W7000225

## Link Rod

The Volvo Air Suspension uses a link rod that is factory adjusted and set to accurately control the dimensions of the air springs, prevent inappropriate adjustments, and avoid unnecessary servicing.

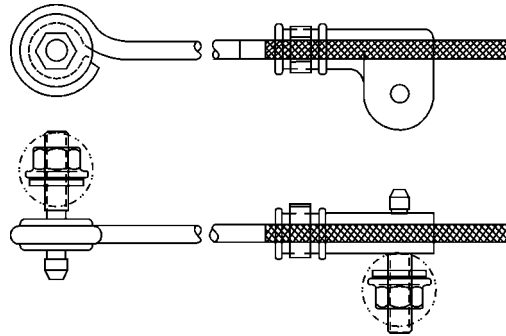

W7000754

## Leveling/Height Valve

The leveling valve was designed to simplify the chassis air suspension system. The quick-dump valve is now combined into the height control valve. This eliminates one valve and the related plumbing.

The valve is located on the left side of the frame rail, adjacent to the fifth wheel.

The Volvo Air Suspension height valve incorporates an integrated dump feature that eliminates the need for a separate valve and allows the rear to be lowered to back under a trailer.

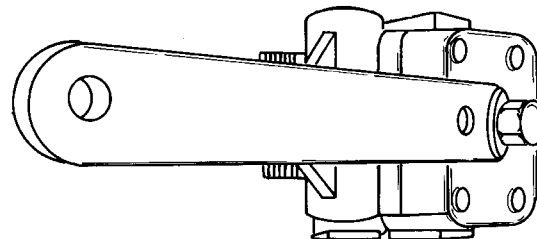

W7000759

## Shock Absorber Bracket, Lower

The lower shock absorber bracket on the Volvo Air Suspension has been redesigned to eliminate the need for left-hand and right-hand versions.

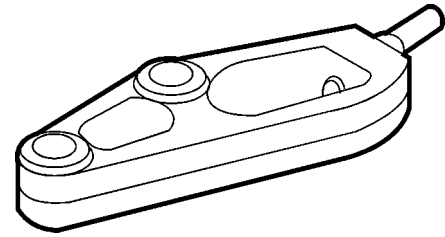

W7000762

## Shock Absorber Bracket, Upper

The upper shock absorber bracket has been redesigned to eliminate the need for left-hand and right-hand versions.

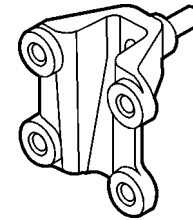

W7000696

## Torque Rod

The torque rod is located on top of the axle housing. It is positioned between the frame rail mounted bracket and the axle housing mounted bracket. It helps maintain lateral alignment of the rear axle or axles for the suspension.

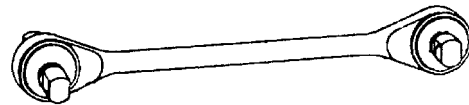

W7000722

# Pneumatic Switch Panel

The pneumatic switch panel can have as many as four optional equipment switches. They regulate air flow directly to the equipment, including:

- Differential Lock
- Wheel and Interaxle
- **Air Suspension Level**
- Fifth Wheel Slide

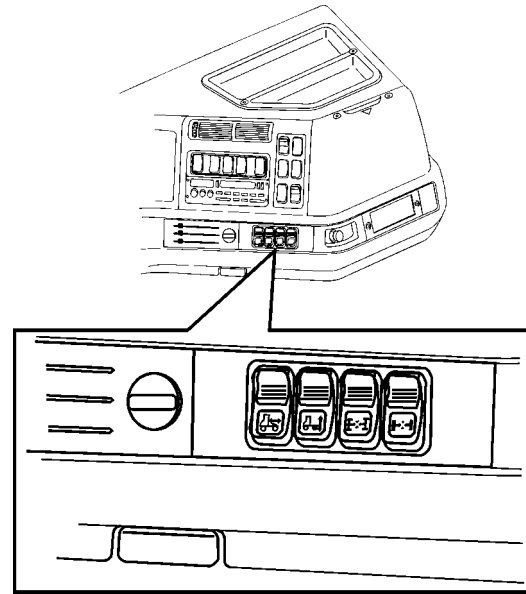

W7000714

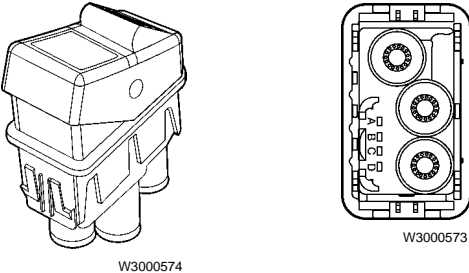
Switch	Switch Function	Terminal			
		A	B	C	D
 <p>W3000574</p> <p>W3000573</p>	Interaxle DLO	To Cluster Telltale Lamp	+12V Supply	Ground	+12V Illumination Control
	Fifth Wheel Slide	To Cluster Telltale Lamp	Not Used	Ground	+12V Illumination Control
	<b>Suspension Dump</b>	To Cluster Telltale Lamp	Not Used	Ground	+12V Illumination Control
	Interwheel DLO	N/A	Not Used	Ground	+12V Illumination Control



## Dump Switch Operation

To “dump” air from the system, push the switch to the position labeled “lower.”

To fill the system, push the switch to the position labeled “ride.”

**Note:** Lower the suspension when disconnecting the trailer.

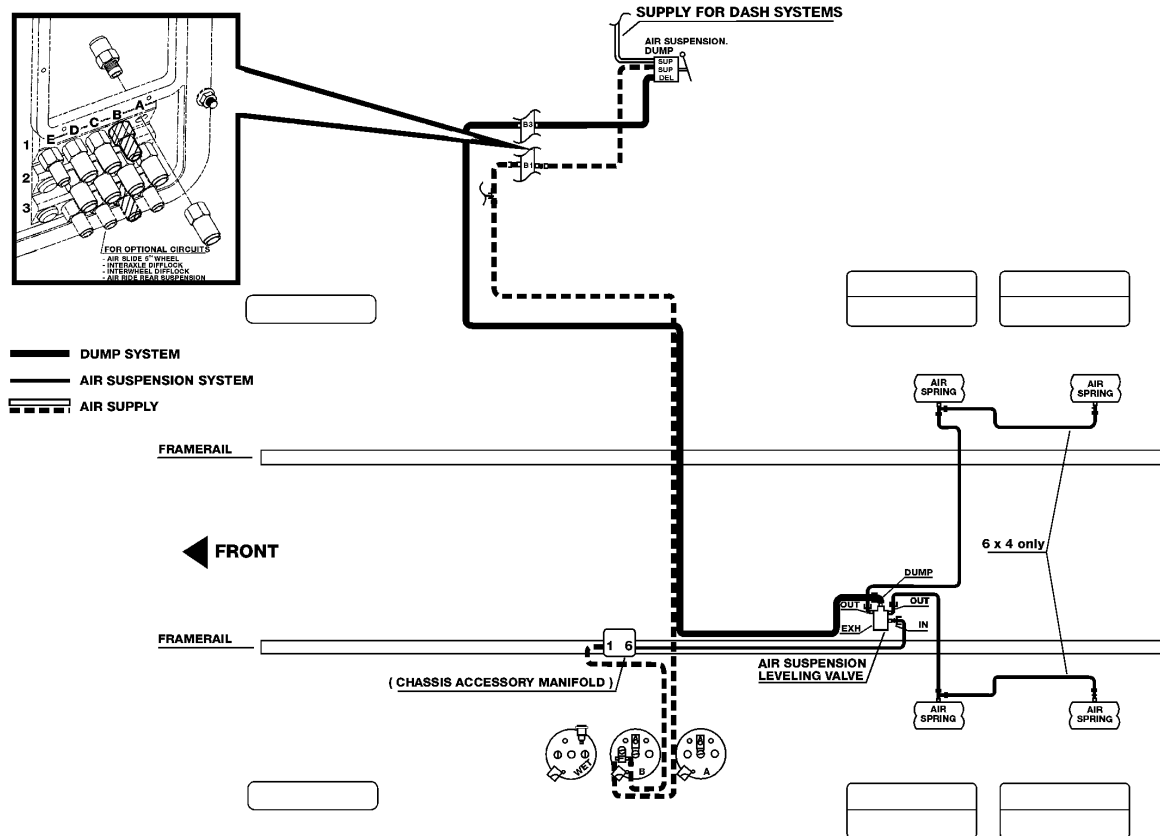

W7000700

Volvo Air Suspension



# Troubleshooting

## Troubleshooting the Volvo Air Suspension

Problem	Cause
Vibration	U-joint angle incorrect
	Improper phasing of drivelines
	Axle inclination incorrect
	Worn wear plate
	Worn radius arm bushing
	Improper ride height
	Broken or defective Z-spring
	Thrust alignment incorrect
	Improper wheel run-out or balance
	Broken or loose U-bolts
	Excessive wheel bearing end play
	Mismatched wheels and tires
Bottoming Out	Broken or defective shock absorber
	Defective leveling valve
	Overloaded vehicle
	Pressure regulator set too low
	Wrong air spring
	Improper ride height
	Broken or defective spring
	Low air pressure
Tracking	Thrust alignment incorrect
	Worn or defective torque rod bushing
	Worn radius arm bushing
	Broken or loose U-bolts
	Broken or defective spring
	Total wheel alignment incorrect
	Lateral alignment of axles incorrect
Ride Height Incorrect	Defective leveling valve
	Ride height not set properly
	Axle inclination incorrect
	Overloaded vehicle
	Defective air spring
Low Air Pressure	Defective manifold
	Defective leveling valve
	Air leak or loose line
	Defective pressure regulator
	Defective dump switch



## Service Procedures

Ride height has a direct relationship with driveline pinion angles. It is critical to maintain all ride height specifications as recommended by Volvo Trucks North America.

Interaxle cancellation (equal forward and rear interaxle U-joint angles) is the key to reduced driveline vibrations and increased component life. "Volvo Air Suspension Ride Height and Driveline Angle Check (Calculation) and Adjustment" page 20, describes how to achieve interaxle cancellation by maintaining the proper ride height and pinion angles.

### Guidelines for Working on the Volvo Air Suspension

To ensure personal safety and to help avoid accidental damage to suspension components, follow these guidelines any time work is performed on the Volvo Air Suspension.

**1**

Chock the front wheels on vehicle and release the parking brakes.



**DANGER**

Personal injury hazard. Never work under the vehicle unless the front wheels are securely chocked. Failure to chock the wheels can result in the vehicle rolling, which can cause serious injury or death to anyone under or near the vehicle.

**2**

Dump (release) the suspension air.



**DANGER**

Stay clear when suspension air is released. Chassis may drop quickly and can cause serious injury or death to anyone under the vehicle.

**3**

When lifting the chassis to perform any procedure, always support the chassis with adequate jack stands before beginning work on the air suspension.

**Note:** Never jack directly under the crossbeam. The crossbeam is not designed to support vehicle weight.



**DANGER**

Personal injury hazard. Never work under or around a raised vehicle unless it is securely supported on jack stands of adequate rating. Failure to use adequate jack stands can result in the vehicle falling, which can cause serious injury or death to anyone under the vehicle.

**4**

To ensure that the U-bolts holding the rear suspension to the drive axle retain their clamp load, observe the following practices:

a. Any time you work on the suspension, make sure you loosen both sides of the suspension on an axle at the same time. It is difficult to realign all parts with opposite side of the axle restricting motion.

b. Whenever the U-bolts are loosened, always support the nose of the axle with an adequate jack.

**DANGER**

Failure to properly support the nose of the axle may result in the axle falling, which can cause serious injury or death to anyone under the vehicle.

c. Whenever the U-bolts are loosened and/or the suspension components attached to the axle are being worked on, make sure that the locating features on each component is properly engaged so that the components are positioned together properly.

d. Make sure that the pin in the radius spring has not been pushed out of position. If the pin is correctly set, make sure that the pin is placed in its proper position relative to the axle seat and Z-spring before clamping it with the U-bolts.

e. Always replace both U-bolts at a particular axle position. The longer of the two U-bolts is positioned to the rear side of the axle housing.

f. Before torquing the U-bolt nuts, position the suspension at approximately the normal ride height and make sure the bolts holding the crossbeam (pedestal plate) to the Z-spring are loosened. This will help provide proper alignment for the Z-springs.

g. Always “snug-up” the U-bolt nuts all over first before torquing, using a handheld clicker-style torque wrench.

**5**

After work has been performed on the air suspension, vehicle realignment may be required. Refer to proper service information.

## Volvo Air Suspension Ride Height and Driveline Angle Check (Calculation) and Adjustment

**WARNING**

The Volvo Air Suspension is set at the factory. Changing the ride height will affect the driveshaft angles and may cause driveline vibration and/or shorten component life. **Ride height adjustments must be performed in accordance with all service manual procedures.**

*Special tools: J-42189*

*Other special equipment: J38460-A, J38460-25*

## Air Suspension Ride Height Check (Calculation)

1

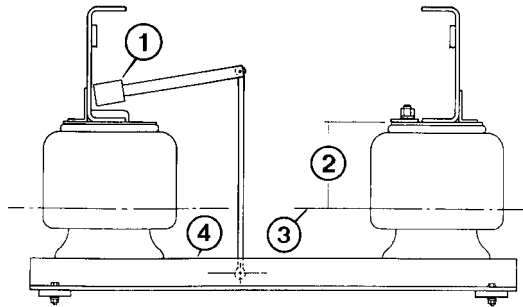

W7000741

- 1 Leveling valve
- 2 Ride height
- 3 Axle center line
- 4 Crossbeam

Before you can accurately calculate the ride height, prepare the vehicle using these steps:

- Measurements must be performed on an unloaded vehicle.
- Park the vehicle on a level surface.
- The steer and rear drive axle tires must be at normal operating pressure.
- Free and center all suspension joints by slowly moving the vehicle back and forth twice without using the brake. When coming to a complete stop, make sure the brakes (parking and service) are released.
- Front wheels must be pointed straight ahead.

2

Chock the front wheels on the vehicle.



Personal injury hazard. Never work under the vehicle unless the front wheels are securely chocked. Failure to chock the wheels can result in the vehicle rolling, which can cause serious injury or death to anyone under or near the vehicle.

3

Dump (release) the suspension air (see "Dump Switch Operation" page 15).



Stay clear when suspension air is released. Chassis may drop quickly and can cause serious injury or death to anyone under the vehicle.

Start the engine and fill the suspension with air. Turn off the engine.

4

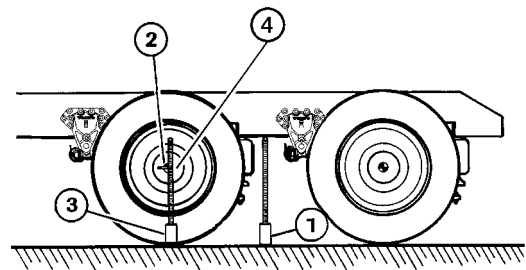

W7000755

The ride height is the distance from the axle centerline to the bottom of the frame rail. The ride height must be within the following specifications:

- Low frame [outside rail height dimension approx. 266 mm (10.5 in.)]: 196–216 mm (7.75–8.5 in.)
- High frame [outside rail height dimension approx. 300 mm (11.75 in.)]: 179–199 mm (7.0–7.75 in.)

To accurately measure ride height:

- a. Measure from the ground to the bottom of the frame rail (1).
- b. Locate the axle centerline (the center hole on the end of the hub works best) using a steel rule or an appropriate tool (2). Measure from the ground to the axle centerline (3).
- c. Calculate the difference between (1) and (3). The difference is the ride height (4).
- d. Ride height should fall within specifications for low- or high-rail chassis (see above).

**5**

Record the measurement for calculation (refer to "Volvo Air Suspension — Calculation Form" page 51). If the measurement is not within the specified range, it must be corrected before proceeding. If the ride height is not in specification, check for the following:

- Excessively worn wear plates (pads).
- Note:** Wear plates (pads) must be replaced in pairs (left and right on same axle); see "Wear Plate (Pad) Replacement" page 40.
- Damaged spring hanger frame bracket.
  - Damaged air spring, Z-spring, and/or radius spring.
  - Damaged link rod.
  - Faulty leveling valve.

Replace the components as necessary, then adjust the suspension ride height (see "Volvo Air Suspension Ride Height Adjustment" page 28).

**6**

Remeasure the ride height using steps 4a-d of this procedure. Repeat as necessary until the measurement is within specifications.

**7**

Proceed to "Interaxle U-joint Angle Cancellation Check (Calculation)" page 22.

## Interaxle U-joint Angle Cancellation Check (Calculation)

**1**

The steps from "Air Suspension Ride Height Check (Calculation)" page 21, must be performed before continuing with this procedure.

**Note:** All angle measurements are relative to level ground.

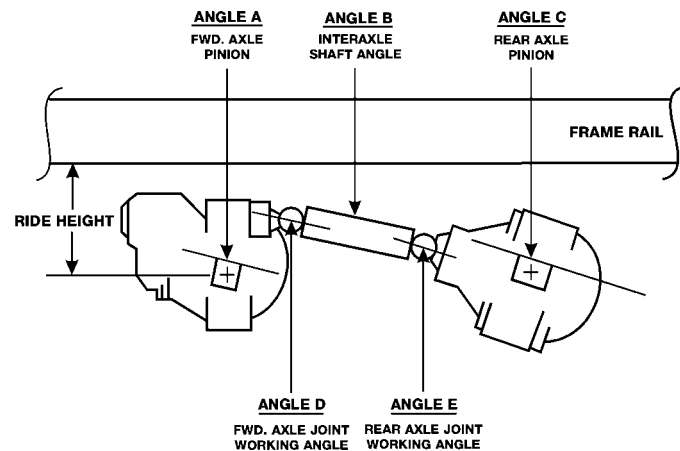
**2**

W7000742

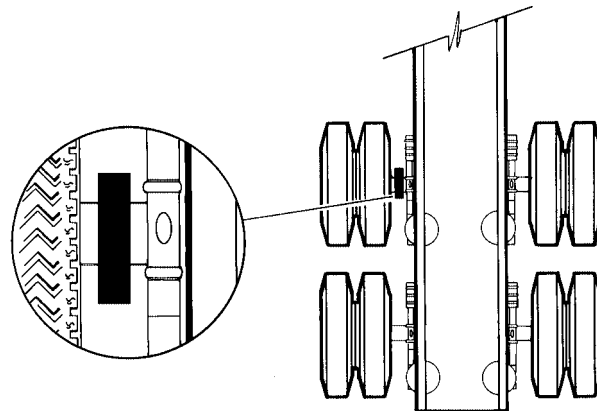

W7000252

Measure the **forward** axle angle (**A**) using an inclinometer or recommended tool. Record the measurement for calculation (refer to "Volvo Air Suspension — Calculation Form" page 51).

**Note:** Wipe surface clean of dirt and debris before taking measurement.



3

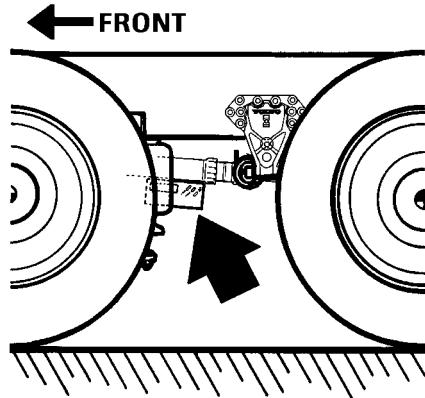

W7000756

Measure the interaxle shaft angle (**B**) using the recommended tooling. Record the measurement for calculation (refer to "Volvo Air Suspension — Calculation Form" page 51).

**Note:** Wipe surface clean of dirt and debris before taking measurement.

4

Calculate :  $B - A = D$

The interaxle angle minus the forward axle angle will give the value (**D**) (refer to "Volvo Air Suspension — Calculation Form" page 51).

5

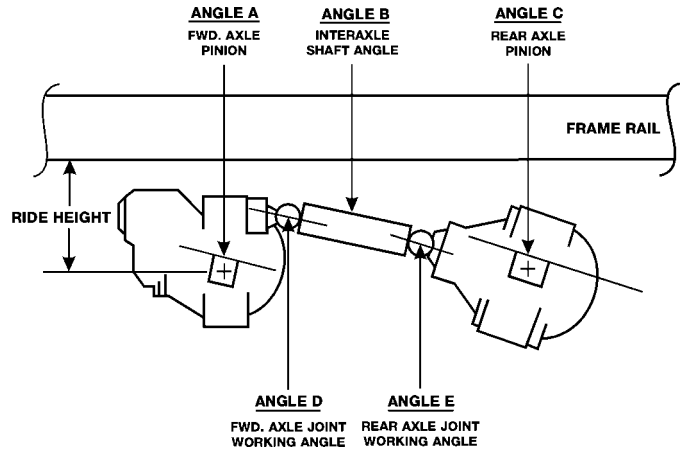

W7000742

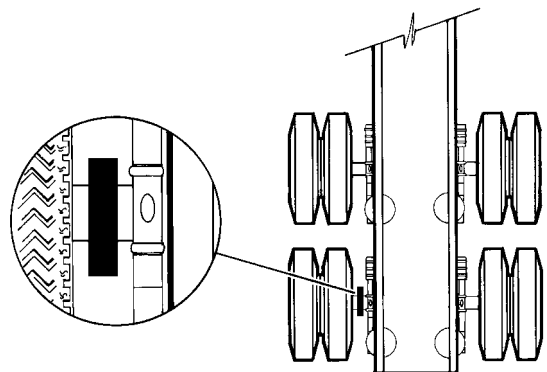

W7000253

Measure the **rear axle angle (C)** using the recommended tooling. Record the measurement for calculation (refer to "Volvo Air Suspension — Calculation Form" page 51).

**Note:** Wipe surface clean of dirt and debris before taking measurement.

6

Calculate:  $C - B = E$

The rear axle angle minus the interaxle angle will give the value (**E**). Record the measurement for calculation (refer to "Volvo Air Suspension — Calculation Form" page 51).

**7**

Calculate:  $D - E = F$

Record the measurement for calculation (refer to "Volvo Air Suspension — Calculation Form" page 51).

Compare the value of angle (**F**) with the following guidelines:

If (**F**) is less than -1.5, lower the ride height.

If (**F**) is between -1.5 and +1.5, no adjustment is necessary.

If (**F**) is greater than +1.5, raise the ride height.

For procedures on lowering or raising ride height, refer to "Volvo Air Suspension Ride Height Adjustment" page 28.

**8**

Proceed to "Forward Axle Pinion Angle to Frame Check" page 25.

# Forward Axle Pinion Angle to Frame Check

1

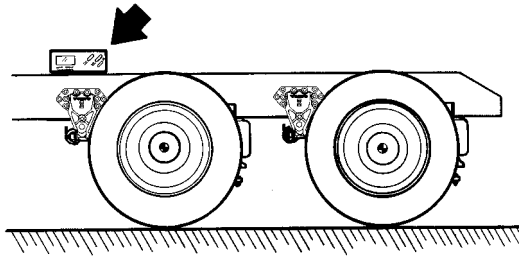

W7000757

Place an inclinometer or recommended tool on top of the frame. "Zero-out" inclinometer or recommended tool.

2

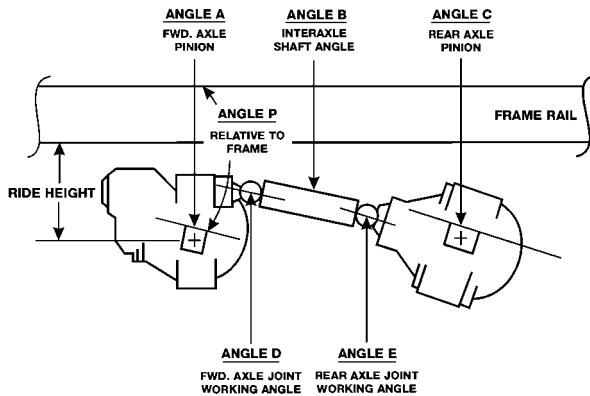

W7000743

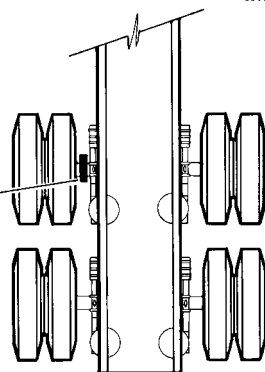
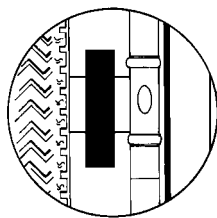

W7000252

Measure the **forward** axle angle (**P**), using the "zero'd out" inclinometer or recommended tool.

3

The angle (P) measurement must be within the specified range, as shown in the following table:

Forward Axle Angle Relative to Frame (P)	
Axle Model	Specification (in degrees)
Tandem, 6x4	2.5 +0/-1
Single, 4x2	3.5 ± 1

If angle (P) is outside the specifications, it must be corrected. Check for the following:

- Excessively worn wear plates (pads).

**Note:** Wear plates (pads) must be replaced in pairs (left and right on same axle); see "Wear Plate (Pad) Replacement" page 40.

- Damaged spring hanger frame bracket.
- Damaged air spring, Z-spring, and/or radius spring.
- Damaged link rod.
- Broken/loose U-bolts.
- Faulty leveling valve.

Replace the components as necessary, then adjust the suspension ride height (see "Volvo Air Suspension Ride Height Adjustment" page 28).

4

Repeat all steps in "Air Suspension Ride Height Check (Calculation)" page 21, "Interaxle U-joint Angle Cancellation Check (Calculation)" page 22, and "Forward Axle Pinion Angle to Frame Check" page 25.

**Note:** If, after the second attempt, the axle pinion angles are still not within specification, perform the "U-bolt Torque Procedure" page 26, as a last attempt to correct the axle pinion angles.

## U-bolt Torque Procedure

Loosening and re-torquing the suspension U-bolts in a particular sequence can influence the axle pinion angle. Both U-bolts on the left and right side on the same axle must be loosened and re-torqued. See "Guidelines for Working on the Volvo Air Suspension" page 19, before performing this procedure.

### Method 1 (preferred)

1

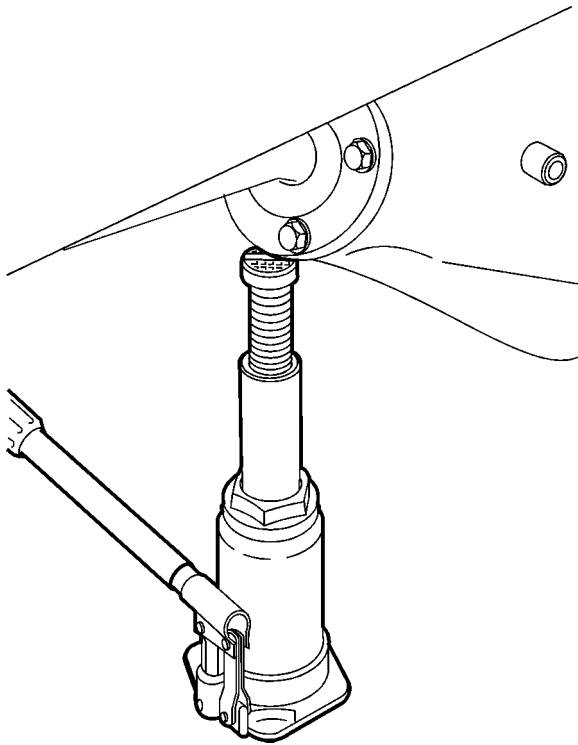

W7000752

Support the nose of the axle with an adequate jack.



**DANGER**

Failure to properly support the nose of the axle may result in the axle rolling forward.

**Personal injury hazard!** Never work under or around a raised vehicle unless it is securely supported on jack stands of adequate rating. Failure to use adequate jack stands can result in the vehicle falling, which can cause serious injury or death to anyone under the vehicle.

2

Loosen the U-bolts enough to allow the bottom plate to be slightly free from the axle housing. Lower the jack slightly, approximately 10–12 mm (0.38–0.50 in.).

3

"Snug-up" the U-bolt nuts so that there is no movement in the bottom plate.

4

**FRONT**

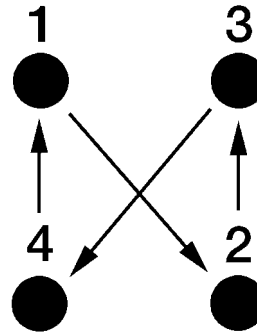

W7000750

Hand-torque the U-bolts to  $500 \pm 75$  Nm ( $369 \pm 55$  ft-lb) for M20, or  $575 \pm 50$  Nm ( $424 \pm 37$  ft-lb) for M22.

M20:  
 $500 \pm 75$  Nm  
( $369 \pm 55$  ft-lb)  
M22:  
 $575 \pm 50$  Nm  
( $424 \pm 37$  ft-lb)

**Note:** Use the "crossover method" (see pattern above) to evenly tighten the U-bolt nuts. Torque nuts in approximately 100 Nm (75 ft-lb) increments until full torque is obtained.

5

Road-test the vehicle to seat components, then re-torque the U-bolt nuts.

6

Re-perform the procedure: "Volvo Air Suspension Ride Height and Driveline Angle Check (Calculation) and Adjustment" page 20. If axle pinion angles are still outside the specifications, proceed with Method 2.

## Method 2

1

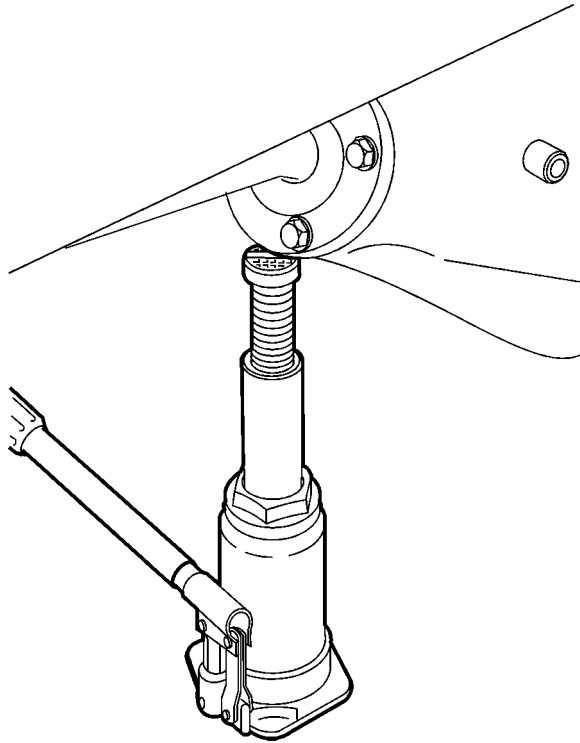

W7000752

Support the nose of the axle with an adequate jack.



Failure to properly support the nose of the axle may result in the axle rolling forward.

**Personal injury hazard!** Never work under or around a raised vehicle unless it is securely supported on jack stands of adequate rating. Failure to use adequate jack stands can result in the vehicle falling, which can cause serious injury or death to anyone under the vehicle.

2

Loosen the U-bolts enough to allow the bottom plate to be slightly free from the axle housing. Lower the jack slightly, approximately 10–12 mm (0.38–0.50 in.).

3

“Snug-up” the U-bolt nuts so that there is no movement in the bottom plate.

4

Hand-torque the U-bolts to  $500 \pm 75$  Nm ( $369 \pm 55$  ft-lb) for M20, or  $575 \pm 50$  Nm ( $424 \pm 37$  ft-lb) for M22.

M20:  
 $500 \pm 75$  Nm  
 ( $369 \pm 55$  ft-lb)  
 M22:  
 $575 \pm 50$  Nm  
 ( $424 \pm 37$  ft-lb)

**Note:** Torquing one U-bolt before the other can influence the axle pinion angle.

Torquing the nuts on the U-bolt on the rear side of the axle housing (left and right) first can **decrease** the axle pinion angle.

Torquing the nuts on the U-bolt on the front side of the axle housing (left and right) first can **increase** the axle pinion angle.

5

Road-test the vehicle to seat components, then re-torque the U-bolt nuts.

6

Re-perform the procedure: “Volvo Air Suspension Ride Height and Driveline Angle Check (Calculation) and Adjustment” page 20.

## Volvo Air Suspension Ride Height Adjustment

1

The suspension ride height is raised or lowered by adjusting the link rod length.

**Note:** If the vehicle is equipped with a non-adjustable (fixed length) rod, it must be replaced with an adjustable link rod before performing this procedure. See "Link Rod Replacement" page 31.

2

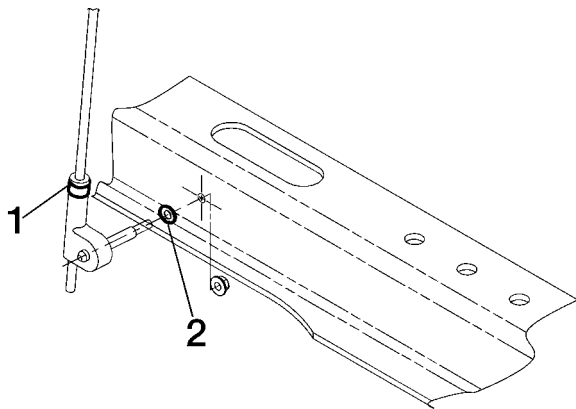

W7000710

- 1 Clamp  
2 Washer

Remove the clamp from the lower end of the link rod. Remove the nut and disconnect the lower end of the link rod from the crossbeam (pedestal plate). The upper end of the link rod should remain mounted to the leveling valve arm during the adjustment procedure.

3

Install a new clamp on the rubber mount on the lower end of the link rod.

**Note:** If using a permanent "crimp" style clamp, you must first remove the rubber mount from the link rod before installing the clamp.

4

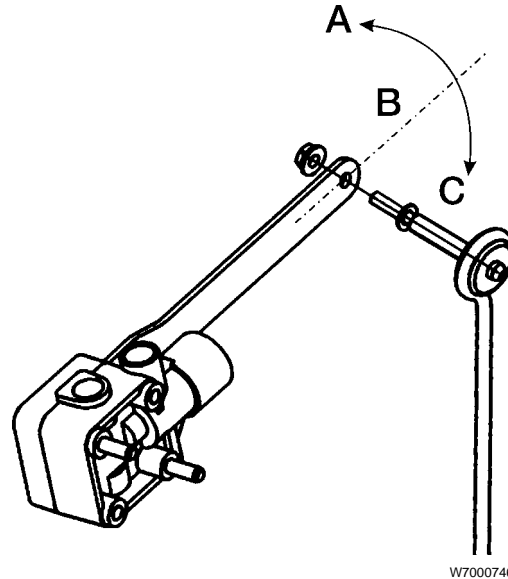

W7000746

- A - Raise  
B - Neutral  
C - Lower

### Raising ride height:

Raise the ride height by holding the leveling valve arm **upwards** until the ride height is within specifications, as follows:

- Low frame [outside rail height dimension approx. 266 mm (10.5 in.)]: 196–216 mm (7.75–8.5 in.)
- High frame [outside rail height dimension approx. 300 mm (11.75 in.)]: 179–199 mm (7.0–7.75 in.)



**DANGER**

Use caution when moving the leveling valve arm down. This will release the suspension air and the chassis may drop quickly, possibly causing serious injury or death to anyone under the vehicle.

**OR**

### Lowering ride height:

Lower the ride height by holding the leveling valve arm **down** until the ride height is within specifications, as follows:

- Low frame [outside rail height dimension approx. 266 mm (10.5 in.)]: 196–216 mm (7.75–8.5 in.)
- High frame [outside rail height dimension approx. 300 mm (11.75 in.)]: 179–199 mm (7.0–7.75 in.)

5

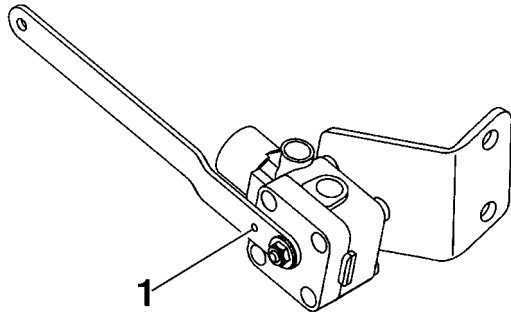

W7000748

Return the leveling valve arm to the neutral position. Place the short side of a 5/32 in. Allen wrench through the hole (1) on the leveling valve arm and into the valve. This locks the arm in the neutral position.

**Note:** If the leveling valve arm is not kept in the neutral position, the ride height may move out of the specified range.

6

Adjust the position of the lower rubber mount on the link rod so that the lower mounting stud is aligned with the hole in the crossbeam (pedestal plate).

7

Reinstall the lower mounting stud of the link rod to the crossbeam. Note the position of the washer. Torque to  $10 \pm 1.5$  Nm ( $7 \pm 1$  ft-lb).

$10 \pm 1.5$  Nm  
( $7 \pm 1$  ft-lb)

**Note:** Do not crimp or tighten the clamp at the lower end of the link rod at this time.

8

Remove the Allen wrench from the leveling valve.

**CAUTION**

Failure to remove the Allen wrench will damage the leveling valve and/or link rod.

9

Dump (release) the suspension air (see “Dump Switch Operation” page 15).

**DANGER**

Stay clear when suspension air is released. Chassis may drop quickly possibly causing serious injury to anyone under the vehicle.

10

Crank the truck to build up air pressure to check the ride height (see “Air Suspension Ride Height Check (Calculation)” page 21). The ride height must be within specifications, as follows:

Low frame [outside rail height dimension approx. 266 mm (10.5 in.)]: 196–216 mm (7.75–8.5 in.)

High frame [outside rail height dimension approx. 300 mm (11.75 in.)]: 179–199 mm (7.0–7.75 in.)

11

Perform the “Interaxle U-joint Angle Cancellation Check (Calculation)” page 22), and the “Forward Axle Pinion Angle to Frame Check” page 25

12

Crimp or tighten clamp at the lower end of the link rod.

## Volvo Air Suspension Component Replacement

**Note:** Before replacing any component or performing any other work on the Volvo Air Suspension, be sure to read "Guidelines for Working on the Volvo Air Suspension" page 19.

### Leveling Valve Replacement

#### CAUTION

Do not try to adjust the leveling valve. Do not take the leveling valve apart. Do not lengthen or shorten the handle on the valve.

#### Removal

1

Chock the front wheels on vehicle and release the parking brakes.

#### DANGER

Personal injury hazard. Never work under the vehicle unless the front wheels are securely chocked. Failure to chock the wheels can result in the vehicle rolling, which can cause serious injury or death to anyone under or near the vehicle.

2

Dump (release) the suspension air (see "Dump Switch Operation" page 15).

#### DANGER

Stay clear when suspension air is released. Chassis may drop quickly and can cause serious injury or death to anyone under the vehicle.

3

Remove the rod from the leveling valve arm.

4

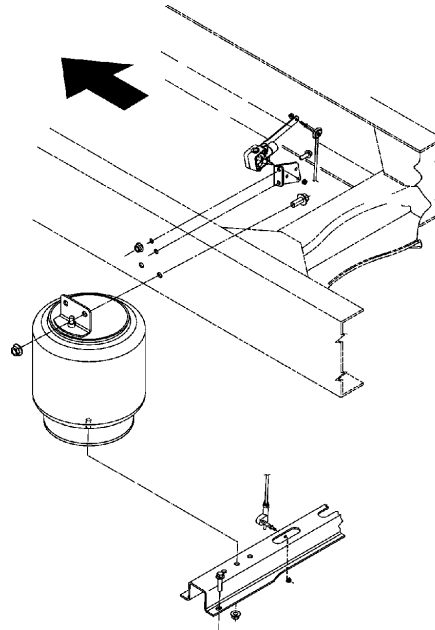

W7000709

Remove the bolts from the frame holding the valve mounting bracket in place.

5

Note the air line positions and orientation to the fittings in the valve. Disconnect the air lines, and remove the valve.

6

Swap fittings (or position new fittings) to the replacement valve.

7

Swap bracket from former valve to replacement valve. Torque to  $10 \pm 1.5$  Nm ( $7 \pm 1$  ft-lb).

$10 \pm 1.5$  Nm  
( $7 \pm 1$  ft-lb)



## Installation

**8**

Lay the valve in the frame and install the air lines.

**9**

Install the bolts through the frame and the valve bracket. Torque bolts to  $60 \pm 10$  Nm ( $44 \pm 7$  ft-lb)  $10$  Nm ( $44 \pm 7$  ft-lb).

**10**

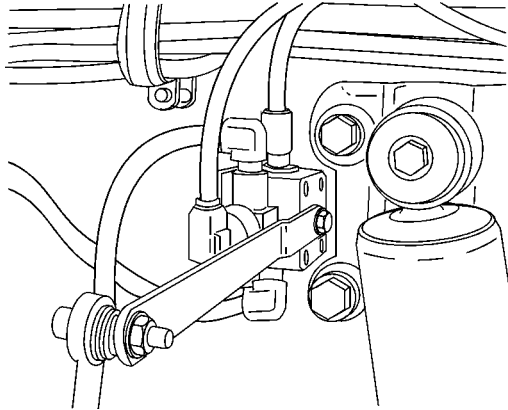

Connect the link rod onto the arm. Torque the rod to  $10 \pm 1.5$  Nm ( $7 \pm 1$  ft-lb).  $10 \pm 1.5$  Nm ( $7 \pm 1$  ft-lb).

**11**

When completed, crank the truck to build up air pressure to check the ride height (see "Air Suspension Ride Height Check (Calculation)" page 21).

The ride height must be within the following specifications:

- Low frame [outside rail height dimension approx. 266 mm (10.5 in.)]: 196–216 mm (7.75–8.5 in.)
- High frame [outside rail height dimension approx. 300 mm (11.75 in.)]: 179–199 mm (7.0–7.75 in.)

See "Volvo Air Suspension Ride Height Adjustment" page 28.

## Link Rod Replacement

### Removal

**1**

Dump (release) the suspension air (see "Dump Switch Operation" page 15).



Stay clear when suspension air is released. Chassis may drop quickly and can cause serious injury or death to anyone under the vehicle.

**2**

Unbolt link rod from leveling valve arm and crossbeam (pedestal). Remove from vehicle.

### Installation

**3**

Pre-set the length of the replacement link rod to approximately 505 mm (19.88 in.).

**Note:** Do not crimp or tighten the clamp at the lower end of the link rod at this time.

4

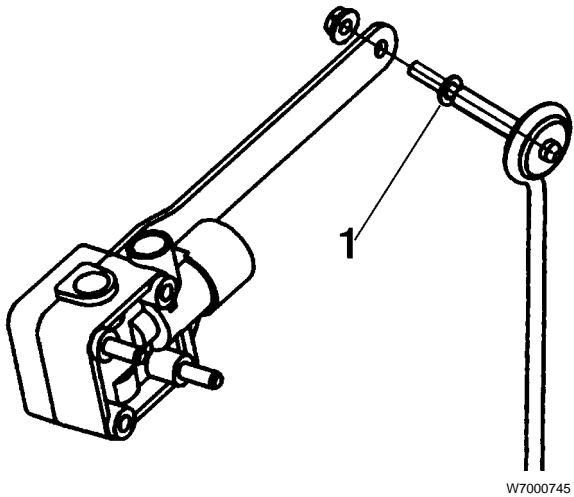

1 Washer

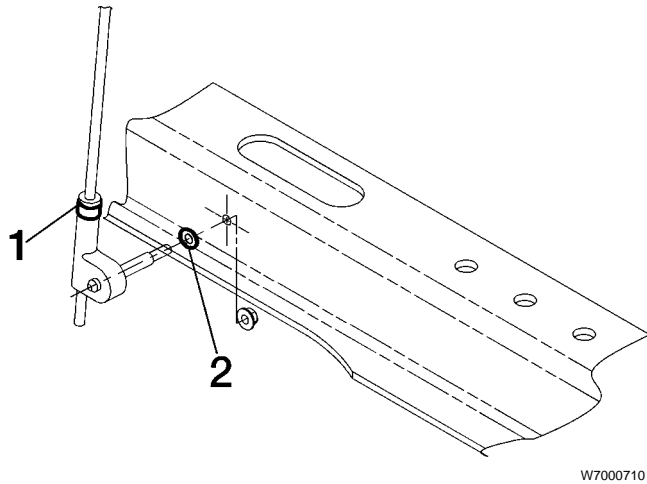

1 Clamp  
2 Washer

Install link rod. Note position of washer. Torque both nuts to  $10 \pm 1.5$  Nm ( $7 \pm 1$  ft-lb).

**Note:** Mount in same hole in the crossbeam (pedestal) as the original link rod. Do not crimp or tighten clamp at lower end of the link rod at this time.

5

When completed, crank the truck to build up air pressure to check the ride height (see "Air Suspension Ride Height Check (Calculation)" page 21).

The ride height must be within the following specifications:

- Low frame [outside rail height dimension approx. 266 mm (10.5 in.)]: 196–216 mm (7.75–8.5 in.)
- High frame [outside rail height dimension approx. 300 mm (11.75 in.)]: 179–199 mm (7.0–7.75 in.)

See "Volvo Air Suspension Ride Height Adjustment" page 28.

6

Crimp or tighten clamp at the lower end of the link rod.

## Crossbeam (Pedestal Plate) Replacement

### Removal

1

Raise the rear suspension and support the frame with jack stands, maintaining the approximate ride height. Dump (release) the suspension air to relieve pressure off the air springs.



Stay clear when suspension air is released. Chassis may drop quickly, possibly causing serious injury to anyone under the vehicle.

2

Remove the nuts that hold the air bags to the crossbeam (pedestal plate). Push the air springs out of the crossbeam and forward.

3

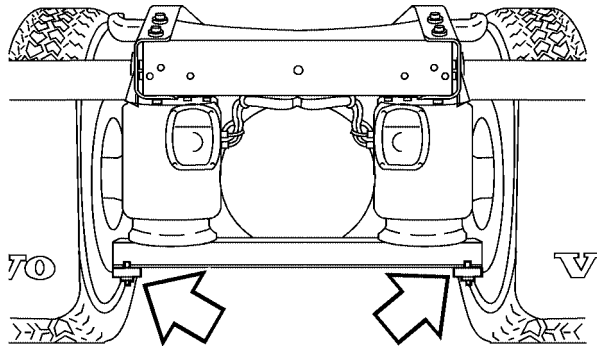

Remove the nuts and bolts that hold the crossbeam to the Z-springs and remove the crossbeam.

### Installation

4

Install the crossbeam to the Z-spring with the nuts and bolts. Torque the bolts to  $105 \pm 20$  Nm ( $77 \pm 15$  ft-lb).

$105 \pm 20$  Nm  
( $77 \pm 15$  ft-lb)

5

Install the air springs back onto the crossbeam and torque the nuts to  $50 \pm 10$  Nm ( $37 \pm 7.5$  ft-lb).

$50 \pm 10$  Nm  
( $37 \pm 7.5$  ft-lb)



Over-torque will damage the air spring.

6

When completed, jack the rear of the truck up, remove the jack stands and lower the vehicle. Crank the truck to build air pressure to raise the air suspension.

# Z-Spring Replacement

## Removal

**1**  
Remove isolator (spring roller) from spring hanger (frame) bracket. This is located under "hook end" of Z-spring.

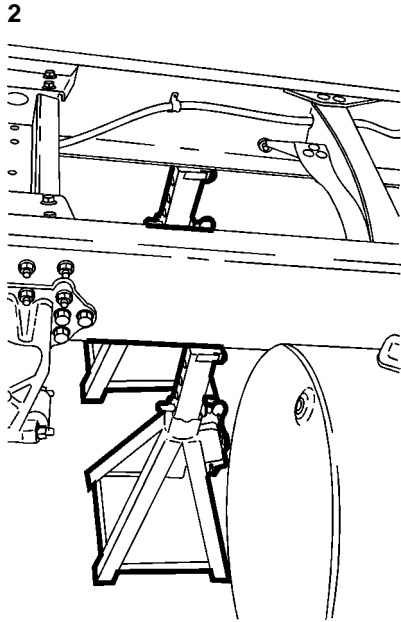

W7000718

**2**  
Chock wheels on vehicle. Jack up vehicle and place jack stands under frame rails. Secure jack stands and lower vehicle.

**Note:** Follow the "Guidelines for Working on the Volvo Air Suspension" page 19.

**DANGER**

Personal injury hazard. Never work under the vehicle unless the front wheels are securely chocked. Failure to chock the wheels can result in the vehicle rolling, which can cause serious injury or death to anyone under the vehicle.

**3**  
Remove wheels and tires on axle (or axles) to be worked on.

**4**

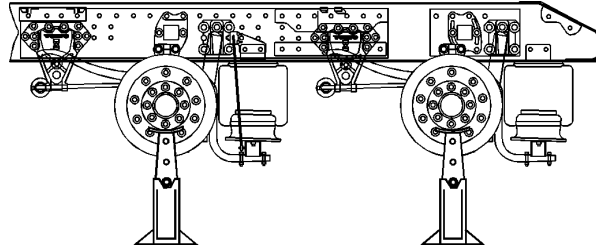

W7000763

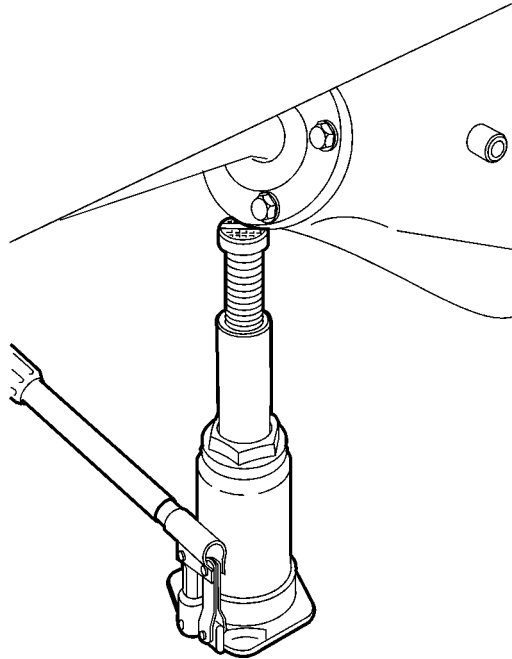

W7000752

Jack up vehicle and place jack stands under axle(s) being worked on. While lowering vehicle onto jack stands, support the nose of the axle with a bottle jack.

**DANGER**

Failure to properly support the nose of the axle may result in the axle rolling forward.

**Personal injury hazard!** Never work under or around a raised vehicle unless it is securely supported on jack stands of adequate rating. Failure to use adequate jack stands can result in the vehicle falling and/or rolling, which can cause serious injury or death to anyone under the vehicle.

5

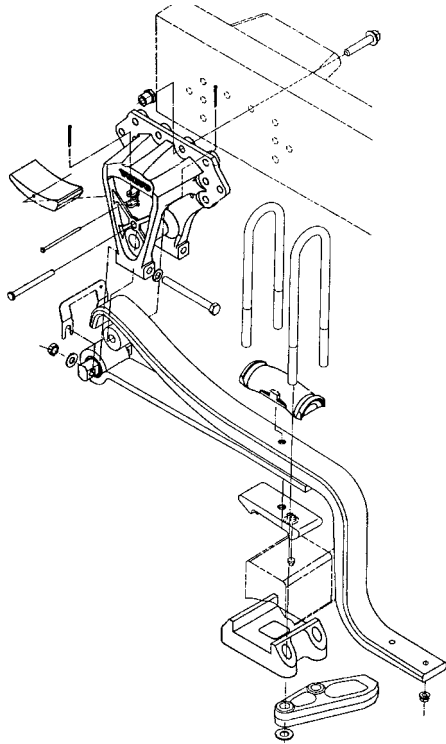

Remove nuts from U-bolts, then remove bottom plate, U-bolts, and top (clip) plate. Leave lower shock bracket attached to shock absorber, but move bracket clear of work area.

6

Remove bolts from crossbeam (pedestal plate).

7

Remove Z-spring.

## Installation

8

Install Z-spring into place.

9

Install bolts to crossbeam. Leave loose; do not torque at this time.

10

Install top (clip) plate, U-bolts, and bottom plate. Reposition lower shock bracket. "Snug up" U-bolt nuts, but do not torque at this time.

11

Raise vehicle and remove jack stands supporting the axle(s).

12

Install wheels and tires. Torque wheel and tire nuts to  $645 \pm 35$  Nm ( $475 \pm 25$  ft-lb.)

$645 \pm 35$  Nm  
( $475 \pm 25$  ft-lb.)

13

Raise vehicle and temporarily remove remaining jack stands supporting the frame rails. Lower the vehicle to the ground.

14

Crank the vehicle to build air pressure to raise the air suspension.

15

Reinstall the isolator (spring roller) with retaining pin and split pin.

16

Support the frame with jack stands (maintaining the approximate normal ride height). Deflate the air springs to relieve pressure off the Z-spring.

17

Center the Z-spring within the spring hanger (frame) bracket.

**Note:** It may be necessary to temporarily position a shim between the left side of the spring and the leg of the spring hanger (frame) bracket to keep the Z-spring centered during the U-bolt nut torque procedure.

**18**

Torque U-bolt nuts to  $500 \pm 75$  Nm ( $369 \pm 55$  ft-lb) for M20, or to  $575 \pm 50$  Nm ( $424 \pm 37$  ft-lb) for M22.

**Note:** To ensure proper torque, refer to "U-bolt Torque Procedure" page 26.

M20:  
 $500 \pm 75$  Nm  
 ( $369 \pm 55$  ft-lb)  
 M22:  
 $575 \pm 50$  Nm  
 ( $424 \pm 37$  ft-lb)

**19**

Torque nuts for crossbeam mounting bolts to  $105 \pm 20$  Nm ( $77 \pm 15$  ft-lb).

$105 \pm 20$  Nm  
 ( $77 \pm 15$  ft-lb)

**20**

Raise the vehicle and remove jack stands supporting frame rails.

**21**

Crank the truck to build air pressure to raise the air suspension. Perform the procedures for "Volvo Air Suspension Ride Height and Driveline Angle Check (Calculation) and Adjustment" page 20.

**Note:** Vehicle realignment may be required. See "Guidelines for Working on the Volvo Air Suspension" page 19.

## Radius Spring Replacement

### Removal

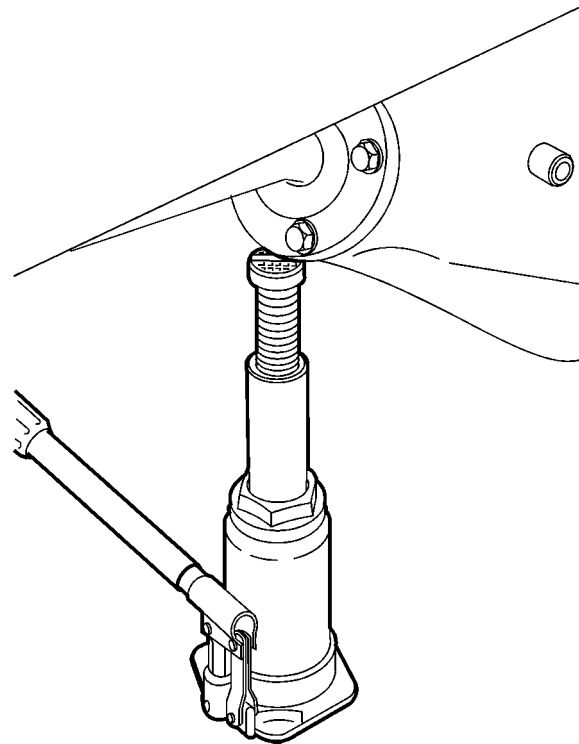
**1**

W7000752

Chock front wheels on vehicle. Jack up vehicle and place jack stands under axle(s) being worked on. Lower vehicle onto jack stands to support the nose of the axle.

**DANGER**

Failure to properly support the nose of the axle may result in the axle rolling forward.

**Personal injury hazard!** Never work under or around a raised vehicle unless it is securely supported on jack stands of adequate rating. Failure to use adequate jack stands can result in the vehicle falling and/or rolling, which can cause serious injury or death to anyone under the vehicle.

**2**

Remove nuts from U-bolts on axle to be worked on.

**Note:** Follow the "Guidelines for Working on the Volvo Air Suspension" page 19.

3

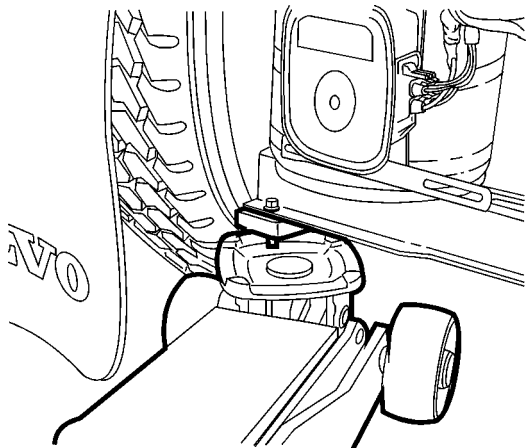

W7000725

Raise vehicle from under the rear of the Z-spring at the crossbeam (pedestal plate) just enough to separate the Z-spring from the radius spring.

4

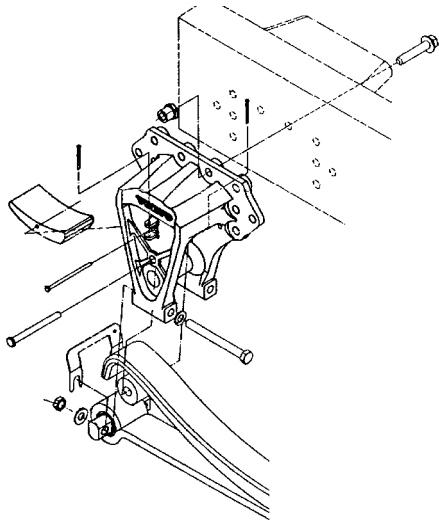

W7000720

Remove the two (2) bolts from the lower part of the spring anchor, then remove the radius spring.

## Installation

5

Install radius spring into place and install the two (2) bolts. Torque to  $275 \pm 45$  Nm ( $203 \pm 33$  ft-lb).

6

Lower vehicle, making certain that Z-spring and radius spring are properly aligned.

7

Install U-bolt nuts, making certain that axle seats are properly aligned with the Z-spring and radius spring. "Snug up" bolts, but do not torque at this time.

8

Loosen (but do not remove) the bolts for the crossbeam (pedestal plate) to Z-spring mounting.

9

Make sure the rear suspension is approximately at normal ride height (air springs inflated).

10

Support the frame with jack stands (maintaining the approximate normal ride height). Deflate the air springs to relieve pressure off the Z-spring.

11

Center the Z-spring within the spring hanger (frame) bracket.

**Note:** It may be necessary to temporarily position a shim between the left side of the spring and the leg of the spring hanger (frame) bracket to keep the Z-spring centered during the U-bolt nut torque procedure.

12

Torque U-bolt nuts to  $500 \pm 75$  Nm ( $369 \pm 55$  ft-lb) for M20, or to  $575 \pm 50$  Nm ( $424 \pm 37$  ft-lb) for M22.

M20:  
 $500 \pm 75$  Nm  
( $369 \pm 55$  ft-lb)

M22:  
 $575 \pm 50$  Nm  
( $424 \pm 37$  ft-lb)

**Note:** To ensure proper, refer to "U-bolt Torque Procedure" page 26.

13

Torque nuts for crossbeam mounting bolts to  $105 \pm 20$  Nm ( $77 \pm 15$  ft-lb).

$105 \pm 20$  Nm  
( $77 \pm 15$  ft-lb)

14

Raise the vehicle and remove jack stands supporting frame rails.

15

Crank the truck to build air pressure to raise the air suspension.

**Note:** Vehicle realignment may be required. See "Guidelines for Working on the Volvo Air Suspension" page 19.

## Torque Rod and Frame Bracket Replacement

### Removal

**1**  
Remove any wires or air line clippings from torque rod.

**2**

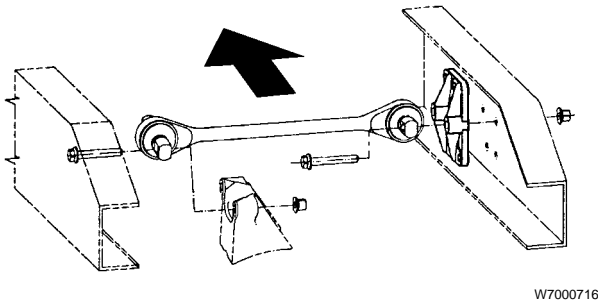

W7000716

Remove the two (2) bolts through torque rod at frame rail side bracket.

**3**  
Remove the two (2) bolts through torque rod at axle housing bracket and remove the torque rod.

**4**  
Remove the four (4) fasteners to the torque rod bracket at the frame rail and remove the bracket.

**Note:** These may be Huck-style fasteners, which require additional effort for removal.



### WARNING

Heating the suspension components and frame rail may weaken them. Hot surfaces can also cause serious burns.

### Installation

**5**  
Install four (4) bolts to torque rod bracket at frame rail.

**Note:** Use only approved fasteners.

**6**  
Install two (2) bolts through torque rod at axle housing bracket.

**7**  
Install two (2) bolts through torque rod at frame rail side bracket.

**8**  
Torque the bolts to torque rod and torque rod bracket to  $320 \pm 50$  Nm ( $236 \pm 37$  ft-lb).

$320 \pm 50$  Nm  
( $236 \pm 37$  ft-lb)

**9**  
Re-attach any wires or air line clippings to the torque rod.



## Spring Hanger (Frame) Bracket Replacement

### Removal

1

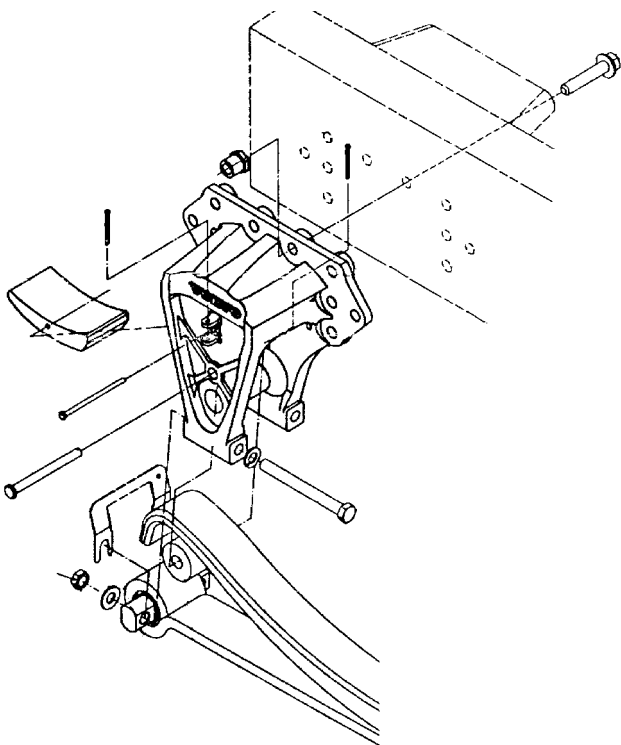

W7000720

Remove the retaining pin and isolator (spring roller) from spring hanger (frame) bracket (located under "hook end" of Z-spring).

**Note:** Follow the "Guidelines for Working on the Volvo Air Suspension" page 19.

2

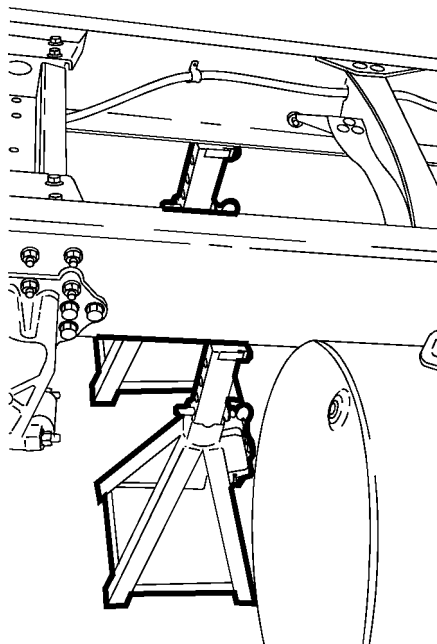

W7000718

Place jack stands on each side of truck and deflate air bags to relieve pressure off of the Z-spring.

3

Remove the nuts and bolts from the radius spring.

4

Remove nuts from the bolts on the spring hanger.

**Note:** These may be Huck-style fasteners, requiring additional effort for removal.



### WARNING

Heating the suspension components and frame rail may weaken them. Hot surfaces can also cause serious burns.

5

Raise the rear of the truck to relieve pressure from the spring hanger bolts.

6

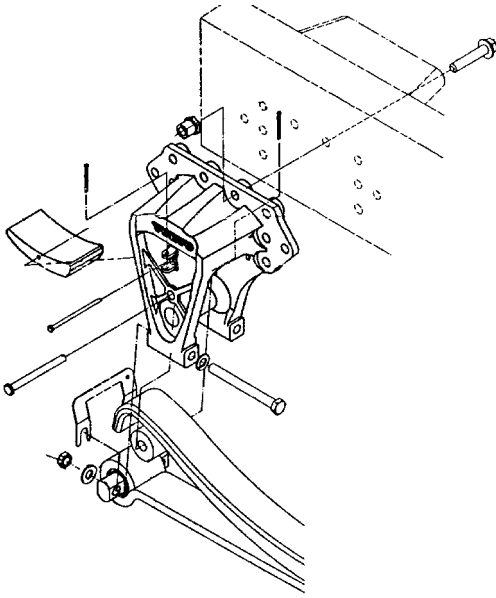

Remove spring hanger bolts in front and behind the bracket.

7

Remove hanger.

8

Remove the split pin and retaining pin holding the wear plate (pad) into the spring hanger (frame) bracket. Remove the wear plate.

**Note:** We recommend replacing wear plates (pads). They should be replaced in pairs (left and right) on the same axle. See "Wear Plate (Pad) Replacement" page 41.

## Installation

9

Install the wear plate (pad), add retaining pin and replacement split pin in the spring hanger (frame) bracket.

**Note:** New plates (pads) should be installed. They should be replaced in pairs (left and right) on the same axle. See "Wear Plate (Pad) Replacement" page 41.

10

Work the spring hanger bracket back onto the Z-spring.

11

Install all bolts to reattach the spring hanger and any other bolts that were removed to get to spring hanger. Torque spring hanger bolts to  $320 \pm 50$  Nm ( $236 \pm 37$  ft-lb).

$320 \pm 50$  Nm  
( $236 \pm 37$  ft-lb)

**Note:** Use only approved fasteners.

12

Install bolts for radius spring. Torque radius spring bolts to  $275 \pm 45$  Nm ( $203 \pm 33$  ft-lb).

$275 \pm 45$  Nm  
( $203 \pm 33$  ft-lb)

13

Install retaining pin and isolator (spring roller) in spring hanger (frame) bracket, under Z-spring.

14

Raise the vehicle and remove jack stands supporting the frame rails. Lower the vehicle to the ground.

15

Crank the truck to build air pressure to raise the air suspension.

16

Ride height and pinion angle may require adjustment. See "Volvo Air Suspension Ride Height and Driveline Angle Check (Calculation) and Adjustment" page 20.

**Note:** Vehicle wheel realignment may be required. See "Guidelines for Working on the Volvo Air Suspension" page 19.

## Wear Plate (Pad) Replacement

### Removal

1

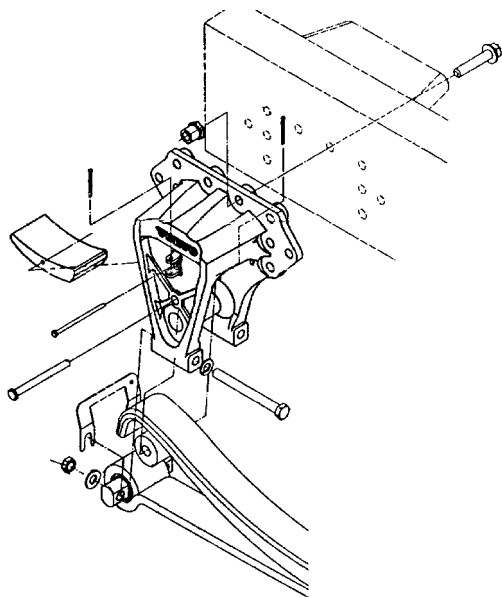

W7000720

Remove the retaining pin and isolator (spring roller) from spring hanger (frame) bracket (located under "hook end" of Z-spring).

**Note:** Follow the "Guidelines for Working on the Volvo Air Suspension" page 19.

**Note:** It is strongly recommended that the wear plates (pads) be replaced in pairs (left and right side) on the same axle.

2

Chock front wheels on vehicle.

**Note:** Follow the "Guidelines for Working on the Volvo Air Suspension" page 19.



**DANGER**  
Personal injury hazard. Never work under the vehicle unless the front wheels are securely chocked. Failure to chock the wheels can result in the vehicle rolling, which can cause serious injury or death to anyone under the vehicle.

3

Dump (release) the suspension air (see "Dump Switch Operation" page 15).



**DANGER**  
Stay clear when suspension air is released. Chassis may drop quickly and can cause serious injury or death to anyone under the vehicle.

4

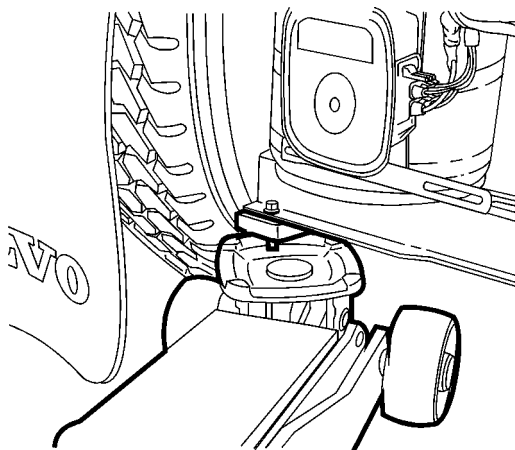

W7000725

Jack the vehicle from under the rear of the Z-spring at the crossbeam (pedestal plate) mounting until there is sufficient gap between the wear plate and Z-spring to remove the wear plate.

**Note:** Jacking both the left and right sides simultaneously will help obtain a sufficient gap. Also, lifting (and properly supporting) the rear of the chassis may increase the size of the gap.

5

Remove the split pin and the retaining pin holding the wear plate into the spring hanger (frame) bracket.

6

Pry out the old wear plate.

## Installation

**7**

Install the replacement wear plate into the spring hanger (frame) bracket.

**Note:** The thick end of the wear plate is always positioned to the rear of the vehicle.

**8**

Install the retaining pin and a replacement split pin into the spring hanger (frame) bracket to hold the installed wear plate.

**9**

Remove the supports and lower the vehicle to the ground.

**10**

Crank truck to build air pressure to raise the air suspension.

**11**

Install the isolator (spring roller), retaining pin, and a replacement split pin in the spring hanger (frame) bracket, under the Z-spring.

**12**

Ride height and axle pinion angle may require adjustment. See "Volvo Air Suspension Ride Height and Driveline Angle Check (Calculation) and Adjustment" page 20.

## Upper Shock Absorber Bracket Removal and Installation

### Removal

**1**

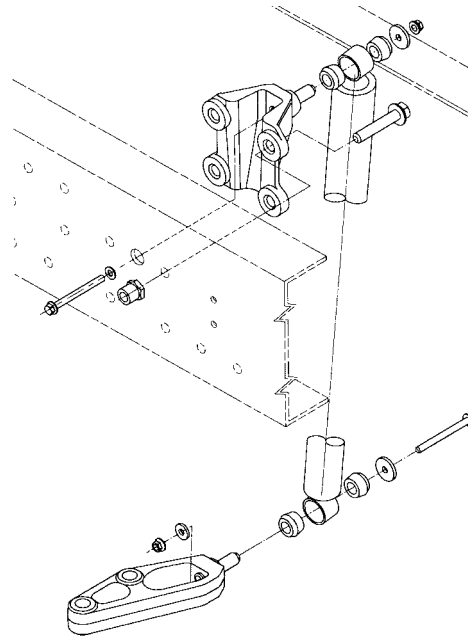

Remove upper shock mounting bolt. Remove shock and position out of the work area.

**2**

Remove frame fasteners from upper shock bracket.

**Note:** These may be Huck-style fasteners, requiring additional effort for removal.

### **WARNING**

Heating the suspension components and frame rail may weaken them. Hot surfaces can also cause serious burns.

**3**

Remove upper shock bracket.

## Installation

- 4**  
Install the shock bracket. Torque fasteners to  $320 \pm 50$  Nm ( $236 \pm 37$  ft-lb).

**Note:** Use only approved fasteners.

- 5**  
Install shock, bushings, and upper shock mounting bolt. Torque bolt to  $60 \pm 10$  Nm ( $44 \pm 7$  ft-lb).

**Note:** When replacing shocks, use only Volvo-approved components (shocks and bushings).

## Lower Shock Absorber Bracket Removal and Installation

### Removal

- 1**  
Chock front wheels on vehicle and remove nuts from U-bolts on axle to be worked on.

**Note:** Follow the "Guidelines for Working on the Volvo Air Suspension" page 19.



**DANGER**

Personal injury hazard. Never work under the vehicle unless the front wheels are securely chocked. Failure to chock the wheels can result in the vehicle rolling, which can cause serious injury or death to anyone under the vehicle.

**2**

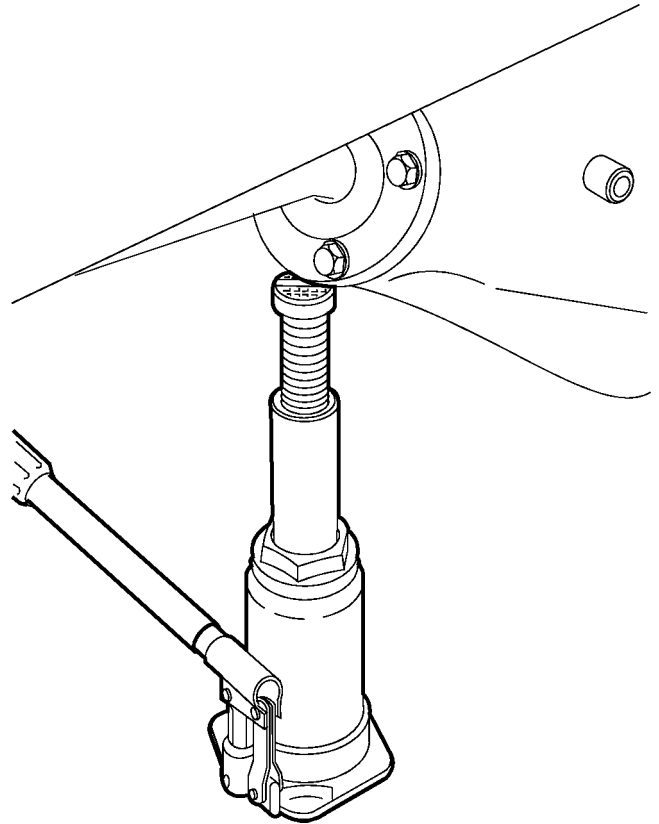

W7000752

Support the nose of the axle with an adequate jack.



**DANGER**

Failure to properly support the nose of the axle may result in the axle rolling forward.

**Personal injury hazard!** Never work under or around a raised vehicle unless it is securely supported on jack stands of adequate rating. Failure to use adequate jack stands can result in the vehicle falling and/or rolling, which can cause serious injury or death to anyone under the vehicle.

3

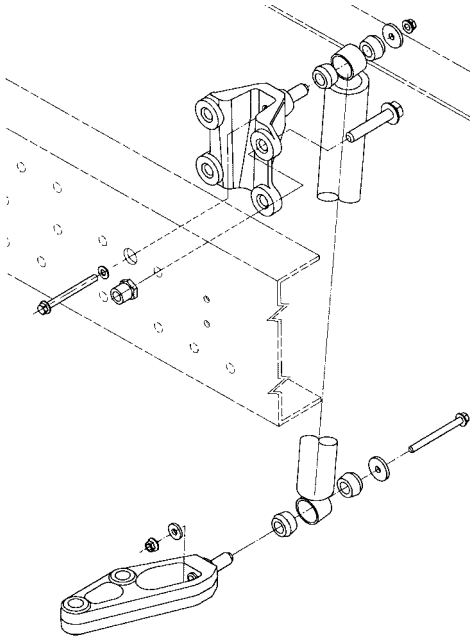

W7000744

Remove nuts from rear U-bolt. Loosen bolts from front U-bolt, but do not remove.

4

Remove lower shock bracket from U-bolt.

5

Remove lower shock mounting bolt and remove lower shock bracket.

## Installation

6

Install shock, bushings, and lower shock mounting bolt. Torque bolt to  $60 \pm 10$  Nm ( $44 \pm 7$  ft-lb).

$60 \pm 10$  Nm  
( $44 \pm 7$  ft-lb)

**Note:** When replacing shocks, use only Volvo-approved components (shocks and bushings).

7

Install lower shock bracket. Install U-bolts and “snug up.”

8

Torque fasteners to  $500 \pm 75$  Nm ( $369 \pm 55$  ft-lb) for M20, or  $575 \pm 50$  Nm ( $424 \pm 37$  ft-lb) for M22.

M20:  
 $500 \pm 75$  Nm  
( $369 \pm 55$  ft-lb)  
M22:

**Note:** To ensure proper torque, refer to “U-bolt Torque Procedure” page 26.

$575 \pm 50$  Nm  
( $424 \pm 37$  ft-lb)

## Shock Absorber Removal and Installation

### Removal

1

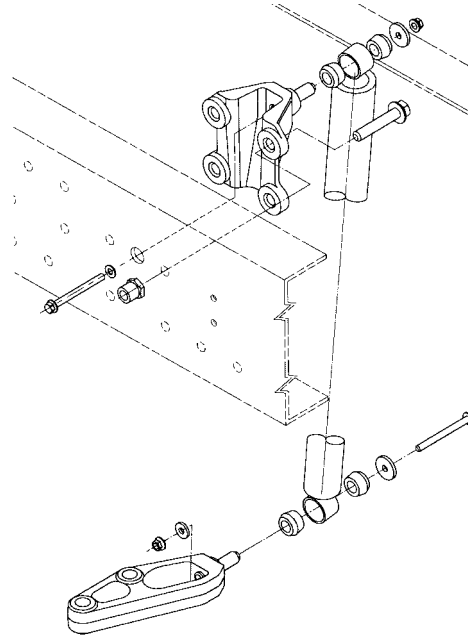

W7000744

Remove lower shock mounting bolt.

**Note:** Follow the “Guidelines for Working on the Volvo Air Suspension” page 19.

2

Remove upper shock mounting bolt and remove shock.

### Installation

3

Install shock and bushings. Torque bolts to  $60 \pm 10$  Nm ( $44 \pm 7$  ft-lb).

$60 \pm 10$  Nm  
( $44 \pm 7$  ft-lb)

**Note:** When replacing shocks, use only Volvo-approved components (shocks and bushings).

## Rear Axle Top Plate/Bottom Plate Removal and Installation

### Removal

1

Chock front wheels on vehicle.

**Note:** Follow the "Guidelines for Working on the Volvo Air Suspension" page 19.



**DANGER**

Personal injury hazard. Never work under the vehicle unless the front wheels are securely chocked. Failure to chock the wheels can result in the vehicle rolling, which can cause serious injury or death to anyone under or near the vehicle.

2

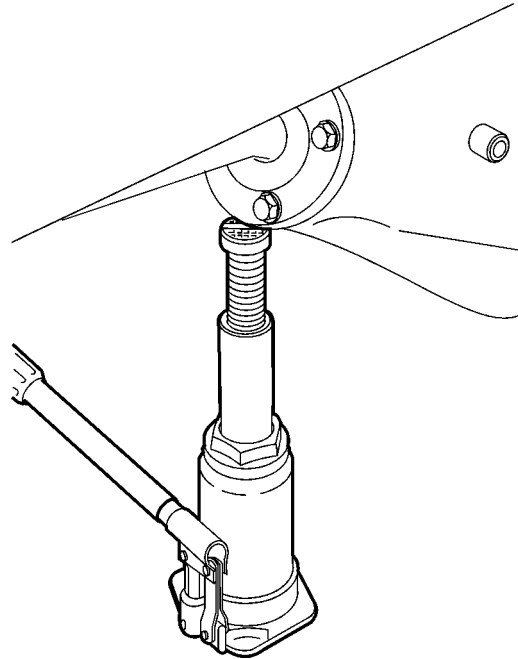

W7000752

Support the nose of the axle with an adequate jack.



**DANGER**

Failure to properly support the nose of the axle may result in the axle rolling forward.

**Personal injury hazard!** Never work under or around a raised vehicle unless it is securely supported on jack stands of adequate rating. Failure to use adequate jack stands can result in the vehicle falling and/or rolling, which can cause serious injury or death to anyone under the vehicle.

3

Remove nuts from the U-bolts, then remove the bottom plate and U-bolts. Leave lower shock bracket attached to shock absorber, but position bracket clear of the work area.

4

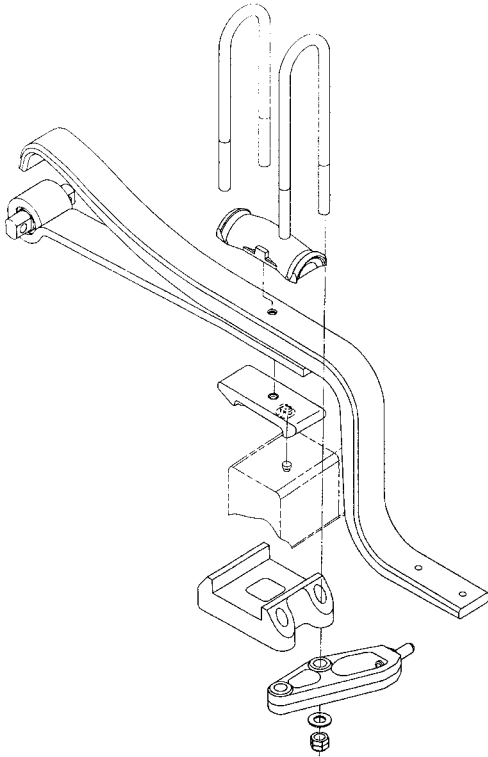

Remove the top plate.

## Installation

5

Install the top plate.

**Note:** Make sure the alignment pin on the bottom of the top plate is engaged into the pocket on the top surface of the Z-spring.

6

Install the U-bolts.

**Note:** The longer U-bolt is positioned to the rear side of the axle housing.

7

Install the bottom plate.

**Note:** Install with the arrow (located on the bottom of the plate) pointing toward the front of the truck.

8

Reposition the lower shock bracket on the U-bolt.

9

“Snug up” the U-bolt nuts, but do not torque.

10

Loosen the mounting bolts for the crossbeam (pedestal plate) to the Z-spring.

11

Remove the jack stands and lower the vehicle to the ground.

12

Crank the truck to build air pressure to raise the air suspension.

13

Support the frame (maintaining the approximate normal ride height). Deflate the air springs to relieve pressure off of the Z-springs.

14

Center the Z-spring within the spring hanger (frame) bracket.

**Note:** It may be necessary to temporarily position a shim between the left side of the spring and the leg of the spring hanger (frame) bracket to keep the Z-spring centered during the U-bolt nut torque procedure.

15

Torque U-bolt nuts to  $500 \pm 75$  Nm ( $369 \pm 55$  ft-lb) for M20, or to  $575 \pm 50$  Nm ( $424 \pm 37$  ft-lb) for M22.

M20:  
 $500 \pm 75$  Nm  
( $369 \pm 55$  ft-lb)  
M22:  
 $575 \pm 50$  Nm  
( $424 \pm 37$  ft-lb)

**Note:** To ensure proper torque, refer to the “U-bolt Torque Procedure” page 26.

16

Tighten the nuts for crossbeam mounting bolts to the Z-spring. Torque to  $105 \pm 20$  Nm ( $77 \pm 15$  ft-lb).

$105 \pm 20$  Nm  
( $77 \pm 15$  ft-lb)

17

Raise the vehicle and remove jack stands supporting frame rails.

18

Crank the truck to build air pressure to raise the air suspension.

**Note:** Ride height and pinion angle may require adjustment. See “Volvo Air Suspension Ride Height and Drive-line Angle Check (Calculation) and Adjustment” page 20.



## Air Spring Removal and Installation

### Removal

**1**  
Support the frame (maintaining the approximate normal ride height). Deflate air springs.

**2**  
Remove air lines from air springs.



**DANGER**  
Pneumatic components store compressed air and can separate violently during disassembly or removal. Before servicing any part of the pneumatic (air) system, completely release the air pressure. Failure to do so can result in serious personal injury or death.

**3**

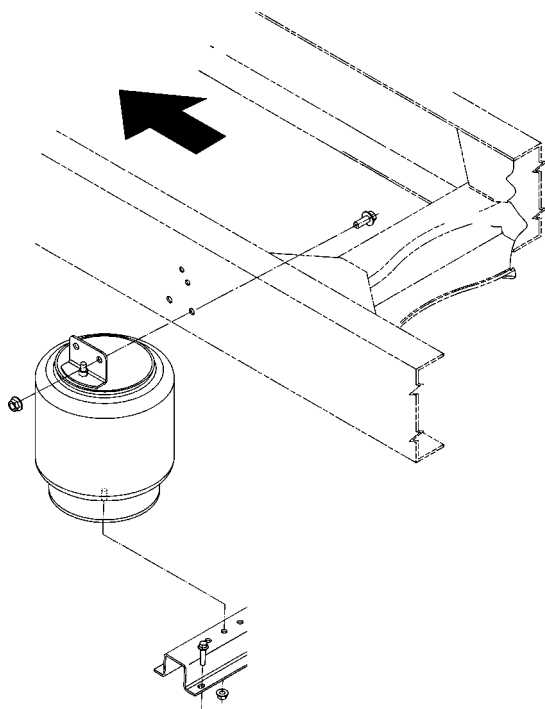

W7000719

Remove the 2 upper frame bolts and bottom nut.

**4**  
Remove the air spring from the chassis.

**5**  
Remove the fitting from the air spring.

### Installation

**6**  
Install the fitting in the air spring.

**7**  
Install the air spring back onto the frame and crossbeam (pedestal plate).

**8**  
Torque frame mounting bolts to  $320 \pm 50$  Nm ( $236 \pm 37$  ft-lb).  $320 \pm 50$  Nm ( $236 \pm 37$  ft-lb)

**9**  
Torque lower nut to  $50 \pm 10$  Nm ( $37 \pm 7.5$  ft-lb).  $50 \pm 10$  Nm ( $37 \pm 7.5$  ft-lb)



**CAUTION**  
Over-torque will damage air spring.

**10**  
Install the air lines into the air springs.

**11**  
Crank truck to build pressure to inflate the air suspension. Remove supports from frame.

**12**  
Check ride height (see "Volvo Air Suspension Ride Height and Driveline Angle Check (Calculation) and Adjustment" page 20).

## Pneumatic switch replacement

**Note:** Make certain the vehicle ignition is OFF before beginning this procedure.

### Removal

1

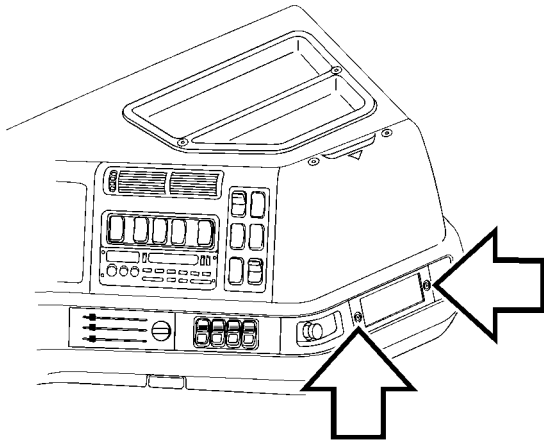

W3000649

Remove the ashtray from the ashtray housing. Remove the 2 screws from the ashtray housing, and remove the housing.

2

Once the ashtray housing is removed, the air switch panel can be removed from the dash. Pull the air switch panel away from the dash and to the left to clear the tip inserts.

3

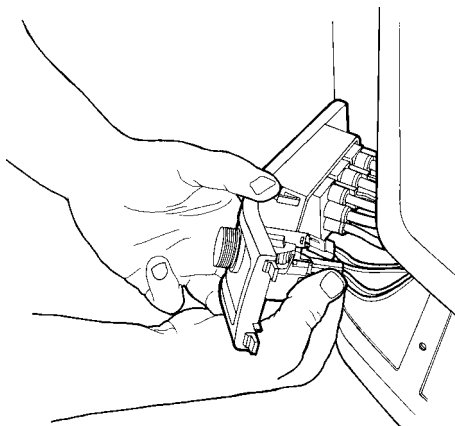

W3000656

Disconnect the 2 terminal connectors from the cigar lighter and the electrical LED connections on the switch being replaced.

4



**DANGER**

Never disconnect an air system component unless all system pressure has been depleted. Failure to deplete system pressure before disconnecting hoses or components may result in them separating violently and causing serious bodily injury.

Drain air pressure from vehicle system. Mark each air line to keep correct arrangement.

5

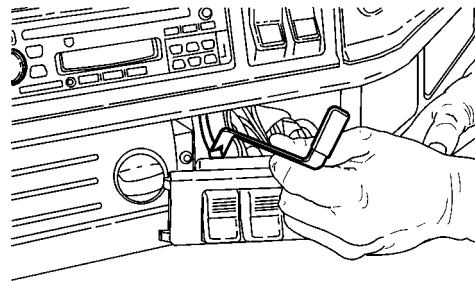

W7000706

Disconnect air lines at switch being replaced by pushing in on the ring and air line using the air line release tool (J-42189), then pulling the air line out.

6

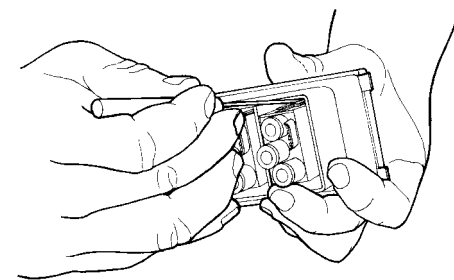

W3000658

To remove switch, insert a no. 1 flat tip screwdriver into back of switch at top and bottom to release locking tabs. Push switch out of the panel.

### Installation

1

Install new air switch into the panel, pushing the switch into the panel until it locks. Push back on the switch to make certain it is locked in the panel.

**2**

Connect air lines to the switch, making sure they are installed in the correct position. Be sure to insert airline to line indicated.

**3**

Connect electrical LED connections on switch, and both cigar lighter connections.

**4**

Align and install switch panel in dash.

**5**

Install ashtray housing with the 2 mounting screws. Torque screws to  $0.4 \pm 0.1$  Nm ( $3.5 \pm 1$  in-lb).

$0.4 \pm 0.1$  Nm  
( $3.5 \pm 1$  in-lb)

**6**

Place ashtray in housing.



# System Check

## Volvo Air Suspension

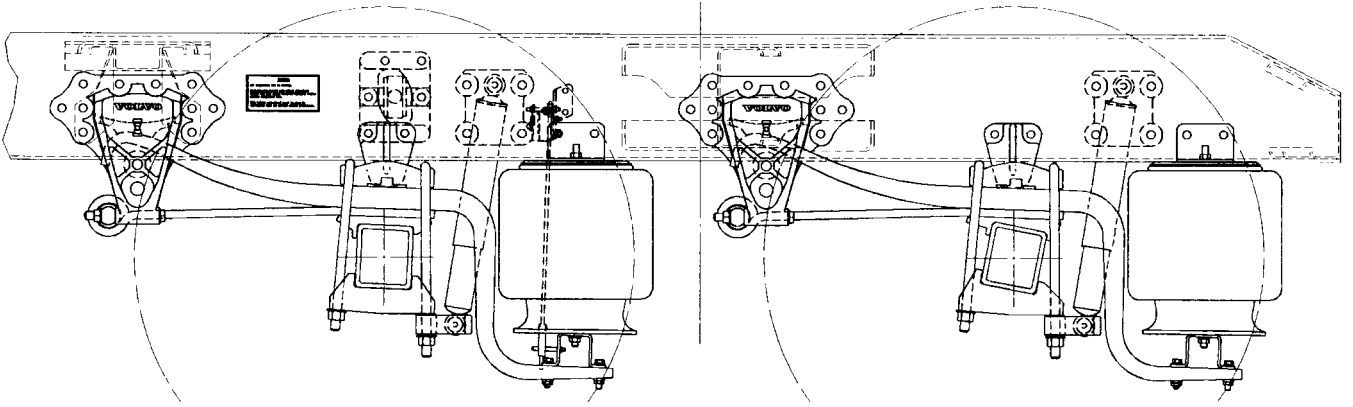

W7000753



# Volvo Air Suspension — Calculation Form

Use this form to record the measurements for calculating ride height and checking pinion angles (all angle measures are in degrees).

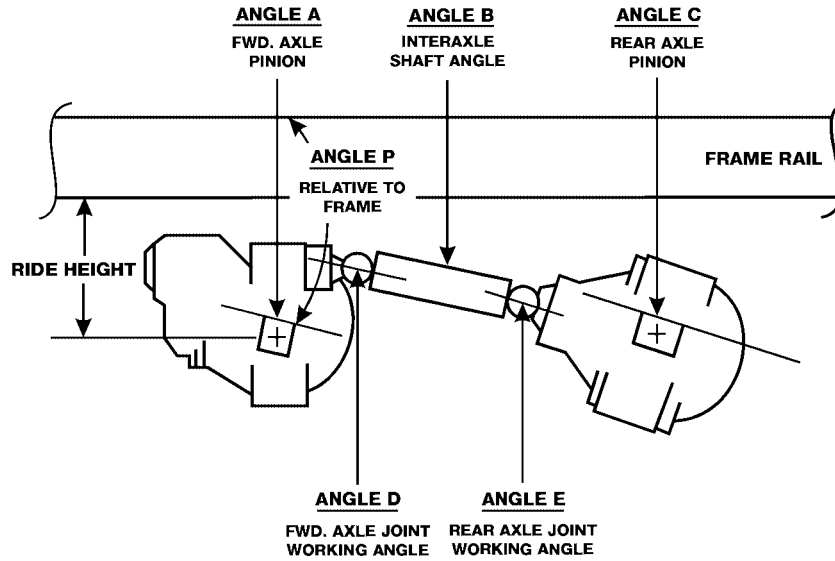

W7000743

	ANGLE	MEASUREMENTS	
		INITIAL	FINAL
1) MEASURE THE RIDE HEIGHT: Ride Height must be within specifications for the following frame types: Low - outside rail height dimension approx. 266 mm (10.5 in.): 196 - 216 mm (7.75 - 8.5 in.) High - outside rail height dimension approx. 300 mm (11.75 in.): 179 - 199 mm (7.0 - 7.75 in.) If ride height is not within specification, it must be corrected before continuing.			
2) MEASURE FORWARD AXLE ANGLE (Relative to the ground)	A		
3) MEASURE THE INTERAXLE SHAFT (Relative to the ground)	B		
4) CALCULATE: $B - A =$ The difference between B and A is value "D"	D		
5) MEASURE THE REAR AXLE ANGLE Relative to the ground	C		
6) CALCULATE: $C - B =$ The difference between C and B is value "E"	E		
7) CALCULATE: $D - E =$	$\pm F$		

<b>ACTION:</b>	<b>LOWER RIDE HEIGHT</b>	<b>No Adjustment</b>	<b>RAISE RIDE HEIGHT</b>
----------------	--------------------------	----------------------	--------------------------

**Note: The Air Suspension ride height cannot fall outside the specified tolerance.**  
 If the adjustment for angle (F) requires that the air suspension ride height be adjusted outside the specified range, see "Troubleshooting the Volvo Air Suspension" page 17.

<b>MEASURE FORWARD AXLE ANGLE (RELATIVE TO FRAME)</b>	<b>SPECIFICATIONS</b>		P		
	Tandem, 6x4	2.5 +0/-1			
	Single, 4x2	3.5±1			

**Note:** If angle (P) is not within tolerance, see "Troubleshooting the Volvo Air Suspension" page 17.





# Operation Numbers

**VOLVO**

**Volvo Trucks North America, Inc.**

P.O. Box 26115, Greensboro, NC 27402-6115

**Volvo Trucks Canada, Ltd.**

6490 Vipond Drive, Mississauga, Ontario L5T 1W8

<http://www.volvotrucks.volvo.com>