

QWIKBREW 2 TWIN BOILER-BREWER

SERVICE MANUAL



Marco Beverage Systems Ltd.
63d Heather Road,
Sandyford Industrial Estate,
Dublin 18,
Republic of Ireland

Ireland Tel: (01) 295 2674
Ireland Fax: (01) 295 3715

UK Tel: (0207) 274 4577
UK Fax: (0207) 978 8141

CONTENTS:

		PAGE
1.	INTRODUCTION	3
2.	SAFETY INSTRUCTIONS	4
3.	BASIC INSTRUCTIONS	5
3.1.	Installation Details	5
3.2.	Operation	6
3.3.	Brewing Coffee	6
3.4.	Hot Water	7
3.5.	Lock Function	7
3.6.	Troubleshooting	8
3.7.	Maintenance	8
3.8.	Cleaning	9
3.9.	Safety	9
4.	TECHNICAL DATA	10
4.1.	General Description	10
4.2.	External Arrangement	12
4.3.	Access to internal components	12
4.4.	Internal Arrangement	13
4.5.	PCBs	14
4.5.1.	PCB Layout	14
4.5.2.	PCB Brewer 2004 – 1600326	15
4.5.3.	PCB Dual Timer – 1600323	17
4.5.4.	PCB Daughter – 1600317	18
4.5.5.	PCB Brewer Display – 1600324	18
4.6.	Operation – Heat Fill Mode	19
4.7.	Operation – Continuous Fill Mode	20
4.8.	Troubleshooting – Diagnostic guide	21
4.9.	Level Probes	23
4.10.	Elements	24
4.11.	Descaling procedure	25
4.12.	Wiring Diagram	26
4.13.	Spare Parts List	29

1. INTRODUCTION:

The information provided in this manual is intended to assist in the installation and maintenance of the Marco Qwikbrew 2 Twin Boiler Brewer. Please read the instructions carefully to prevent accidents and ensure an efficient installation.

This manual is not a substitute for any safety instructions or technical data affixed to the machine or its packaging. All information in this manual is current at the time of publication and is subject to change without notice.

Only technicians or service providers authorised by Marco should carry out installation and maintenance of these machines.

Marco accepts no responsibility for any damage or injury caused by incorrect or unreasonable installation and operation.

2. SAFETY INSTRUCTIONS:

- Read all instructions.
- To protect against electric shock do not immerse mains cord in water or other liquid.
- To prevent chafing of the cable, do not let the mains cord hang over the edge of a table or counter; or touch hot surfaces.
- Do not operate any appliance with a damaged cord, plugs, or after the appliance malfunctions or has been damaged in any manner.
- Switch off at the mains (unplug or disconnect from outlet) and turn off the water supply when not in use and before cleaning. Allow to cool before removing components.
- The use of spares and accessories not recommended by Marco may cause damage and/or injuries.
- Do not use outdoors. Do not place on or near a hot gas or electric burner.
- Do not use the appliance for anything other than its intended use.
- Save these instructions.

3. BASIC INSTRUCTIONS:

This is a copy of the instruction manual that goes out with every unit.

3.1. INSTALLATION DETAILS:

Electrical installation:

Electrical specification: 5.6 kW/230V ac & 6 kW/230V ac.

- This unit must be connected to a suitable single phase power supply with reference to the rating plate. This should be done by a qualified electrician.

Electrical specification: 8.4kW/400V ac. 3 PHASE

- This unit must be connected to a suitable 3 phase power supply with reference to the rating plate. This should be done by a qualified electrician
- When power is applied to the machine, the LEDs on the display PCB will flash a number of times – this indicates which version of software code is in the machine.

Plumbing installation procedure:

Note: Marco recommend that this machine be positioned on a counter with a drainage facility. Marco cannot be held responsible for any flood damages.

- Mains water pressure required (limits): 5-50psi (35-345kPa)
- Fit a stop Valve on a cold water line and attach a 3/4" BSP male fitting, (e.g. 3/4" x 1/2" 311 or washing machine type stop valve).
- Connect straight tailpiece of the inlet hose to the stop valve fitting. Make sure that the pre-attached sealing washer is fitted.
- Turn on the water to flush any impurities, dust etc from the inlet hose and water pipe. Allow several gallons through.
- Connect right-angled tailpiece of the hose to the inlet valve of the boiler (again 3/4" BSP). Make sure the sealing washer is fitted here also.
- Turn on water and check for leaks.

Start-up:

- Check that all installation procedures have been carried out.
- Turn the water on at the stop valve and switch the power on at the isolator switch. The sight-glass lamp will illuminate.
- Switch the machine on by pressing the button associated to the 'POWER' text on the left control panel. This button should be held until the red light illuminates. The machine will automatically take in water. To switch off, press the button again.

3.2. OPERATION:

The Marco Qwikbrew 2 Twin uses the 'Continuous fill cycle' as standard.

Continuous Fill Mode:

- Water will be taken in until the machine is full. The heating begins when the quantity of water is at a safe level above the elements and stops when the machine is full and up to temperature.
- Once the water is up to temperature, the green 'Ready to Brew' lights illuminate (approximately 50 minutes after start up). A brew can be selected at this point.
- The 'Continuous fill mode' essentially keeps the machine full of water, regardless of temperature. In this mode the machine will never run out of water, but misuse (e.g. filling buckets for cleaning) can allow cold water to be served. Using hot water at a faster rate than the machine can recover will result in a temperature drop in the beverage. Recovery rate is approximately 1.5 pints/min.

Heat-fill mode (Optional):

- This mode of operation is available as an option, but a service agent is required to make this change.
- Water will be taken in until it is a safe level above the elements. At this point the water stops and heating begins. Once this quantity of water is up to temperature, another small quantity of cold water is taken in while the heating continues. This heat fill cycle maintains the correct temperature in the tank.
- When the machine has enough water to brew coffee, the green 'Ready to Brew' lights illuminate (after approximately 40 minutes). A brew can be selected at this point, but the machine is NOT full yet and will continue to fill. After approximately 50 minutes the heaters will shut off. The machine is now full and up to temperature.
- Tea and coffee is at the optimum temperature when operating under the heat-fill mode.

3.3. BREWING COFFEE:

- Slide out the coffee filter bowl and place a single sheet of filter paper in the bowl.
- Put the correct amount of ground coffee into the filter paper. Your coffee supply company may have pack sizes to suit the brews of your new Maxibrew 2 Twin; if not, as an approximate guide for your first brews:
 - 110g-120g (4-4½oz) for a Half Brew (5 pints [2.85 litres])
 - 220g-240g (8-8½oz) for a Full Brew (10 pints [5.7 litres])Depending on the coffee grind and roast, and on water quality, you may have to adjust these quantities to obtain the optimum flavour.
- Level off the surface of coffee by gently shaking the filter bowl. Slide the coffee filter bowl into the guide rails in the brew head and push fully home.

- Select the correct brew on the relevant control panel (e.g. left control panel if the left urn being used) by pressing either the Half Brew switch for a 5 pint brew or the Full Brew switch for a 10 pint brew. Press the switch until the amber light illuminates. If you make a mistake press the Power switch to turn the machine off. Wait 3 seconds and turn back on again. Select the correct brew.
- A half brew should take around 4 min - 4 min 45 secs. A full brew should take around 8 mins - 9 mins 30 secs. These depend on the set up of the machine (factory).

Note: A service agent can set the machine up so that different brew times are available in each urn, for different strengths/types of coffee. Half-brew times can be varied from 3 mins +/- 10 seconds to 7 mins +/- 10 seconds and Full-brew times can be varied from 6 mins +/- 10 seconds to 14 mins +/- 10 seconds.

- Remove the filter paper with the spent grinds as soon as possible after brewing.

Note: allow time for all the coffee to drain from the filter bowl before removing.

- A brew should only be selected whenever the green 'Ready to brew' lights are illuminated.
- Left and right brews can run simultaneously (although the two brew buttons should not be depressed at exactly the same time. Press and release one brew button before doing the same on the other side).

Note: The Maximum hourly coffee output is 108 Pints (61 Litres) for Continuous-Fill and 108 Pints (61 Litres) for Heat-Fill.

3.4. HOT WATER:

- When the machine is full, up to 17.5 pints/10 litres of water is available for tea etc. If all this water is used and no water is available at the hot water tap, the machine should be left for a short while to recover (Heat-fill mode). The recovery rate of this machine is approximately 1½ pints (0.87 litres) per minute at 5.6 kW.
- Using hot water at a faster rate than the machine can recover will result in a temperature drop in the beverage (Continuous fill mode).

Note: A brew can still be selected after all the hot water has been drawn off the hot water tap. While the machine is brewing, however, the hot water recovery rate is reduced and the machine will take longer to replenish the hot water supply.

3.5. LOCK FUNCTION:

The Qwikbrew 2 Twin has a button lock function to prevent untrained personnel operating the machine, or accidental misuse by trained personnel. If the lock button (left hand side control panel) is pressed for approximately 6 seconds, a red light next to the button will illuminate. Both control panels are now 'locked'. No buttons are operational when the lock function is enabled. The machine will operate as normal,

i.e. if the machine is brewing, it will continue to brew. Once completed another brew cannot be selected until the lock is disabled.

Note: The 'Ready to Brew' lights will still be on, but no brew can be selected.

To disable the lock function – hold the lock button for approximately 6 seconds once again.

3.6. TROUBLESHOOTING:

The Marco Qwikbrew 2 Twin uses an electronic diagnostic system to help determine faults. If an error is detected a sequence of flashes is displayed through the POWER light. This sequence is repeated (cycled) until:

- 1) The problem is rectified by a service agent, or
- 2) In the case of the 6 flash cycle – the machine senses that normal operation has resumed, and the flash sequence ceases.

The number of flashes in a cycle corresponds to the symptom in the table below:

Note: Some of the error sequences will be displayed if there is low water pressure. Please check that there is water pressure and that the water stop-valve is open before calling your service agent.

Status/Diagnostic light guide:

No of flashes	Symptom	Action required
2	Water level below elements. Normal when machine first fills.	Check water pressure, if this is OK - call service agent.
3	Temperature sensor failure (o/c)	Call service agent
4	Water not heating	Call service agent
5	Temperature sensor failure (s/c)	Call service agent
6	Machine not filling	Check water pressure. If this is OK and the machine has not returned to normal operation after 15 min – call service agent

3.7. MAINTENANCE:

Marco machines have been designed to give many years of trouble free service. Marco Beverage Systems design, manufacture and test to ISO9001:2000 standard. The only regular maintenance required is occasional de-scaling.

In common with all water boiler manufacturers, service calls resulting from limescale are not covered by warranty. Fitting a scale reducer is recommended, especially in hard water areas. This can reduce the build-up of scale but may not stop it altogether. A service agent should descale the machine regularly. The frequency that descaling is required depends on the local water supply; hard water areas need more attention. Marco suggest that the machine be descaled every 3 months if the unit is in a hard water area. In soft water environments every 6 months should suffice.

3.8. CLEANING:

Like any cooking utensils the coffee urns of your Qwikbrew 2 Twin must be cleaned properly and regularly. Marco recommend cleaning after each days brewing using a proprietary urn-cleansing compound.

Marco Urn Cleanser (Marco Part number 8000240) is available in 800g tubs. Instructions are given on each tub. Your Qwikbrew 2 Twin is supplied with one large urn cleaning brush and one small sight-glass cleaning brush – to ensure thorough cleaning. In order to clean the sightglass, unscrew the small plugs on the top of the sightglass. The sightglass is fragile, so be careful while cleaning.

The exterior of these machines may be cleaned with a damp cloth and a light detergent. Do not use abrasive cloths or creams, as this will spoil the finish of the machine. Do not use a water jet or spray. Beware of accidentally operating the draw off taps when cleaning the front of the machine.

3.9. SAFETY:

- This appliance must be earthed.
- Risk of flooding. The hose supplied with this unit is non-toxic food quality tested to 190psi. However, a hose is not a permanent connection. It is, therefore, advisable to switch off boiler and close the stopcock valve when boiler is not in use, e.g. overnight, weekends etc.
- Risk of scalding. Beware of accidentally operating the water drawoff tap especially when cleaning the front of the boiler. ALL users of this machine should be trained and should be aware that the machine dispenses very hot beverages.
- The utmost care has been taken in the manufacture and testing of this unit. Failure to install, maintain and / or operate this boiler according to the manufacturer's instructions may result in conditions that can cause injury or damage to property. If in any doubt about the serviceability of the boiler always contact the manufacturer or your own supplier for advice.

4. Technical Data:

4.1. GENERAL DESCRIPTION:

QWIKBREW 2 TWIN – 5.6 kW (STANDARD)		
Electrical	Connection	5.6kW,230Vac c/w 1.5m flex
Plumbing	Fittings Pressure	0.75" BSP Food grade inlet hose supplied 5-50 psi (35-345 kPa)
Dimensions	Height Height incl. Cup Rail Width Depth (footprint on counter) Depth Depth incl. Drip Tray	695mm 745mm 655mm 465mm 570mm 620mm
Performance	<u>Coffee Output:</u> 1 x Half brew: 2 x Half brew: 1 x Full Brew: 2 x Full Brew: Maximum Hourly Coffee Output: <u>Hot Water:</u> Immediate Draw Off: Total Recovery rate at: 5.6KW	Up to 2.84 litres (5 pints) Up to 5.68 litres (10 pints) Up to 5.68 litres (10 pints) Up to 11.36 litres (20 pints) Up to 57 litres (100 pints) <u>Heat Fill Mode:</u> Up to 15 litres (26 pints) when full. <u>Continuous Fill Mode:</u> 4.5 litres (8 pints) recommended max. 50 litres/hr (88 pints/hr)

QWIKBREW 2 TWIN – 6kW (NON-STANDARD)		
Electrical	Connection	5.6kW,230Vac c/w 1.5m flex
Plumbing	As above	
Dimensions	As above	
Performance	<u>Coffee Output:</u> 1 x Half brew: 2 x Half brew: 1 x Full Brew: 2 x Full Brew: Maximum Hourly Coffee Output: <u>Hot Water:</u> Immediate Draw Off: Total Recovery rate at 6kW:	Up to 2.84 litres (5 pints) Up to 5.68 litres (10 pints) Up to 5.68 litres (10 pints) Up to 11.36 litres (20 pints) Up to 57 litres (100 pints) <u>Heat Fill Mode:</u> Up to 16 litres (28 pints) when full. <u>Continuous Fill Mode:</u> 5 litres (8.8 pints) recommended max. 53 litres/hr (94 pints/hr)

QWIKBREW 2 TWIN – 8.4kW (NON-STANDARD)		
Electrical	Connection	8.4kW,400V (3Phase+Neutral) c/w 1.5m flex
Plumbing	As above	
Dimensions	As above	
Performance	<u>Coffee Output:</u> 1 x Half brew: 2 x Half brew: 1 x Full Brew: 2 x Full Brew: Maximum Hourly Coffee Output: <u>Hot Water:</u> Immediate Draw Off: Total Recovery rate at 8.4kW:	Up to 2.84 litres (5 pints) Up to 5.68 litres (10 pints) Up to 5.68 litres (10 pints) Up to 11.36 litres (20 pints) Up to 57 litres (100 pints) <u>Heat Fill Mode:</u> Up to 22.5 litres (40 pints)when full. <u>Continuous Fill Mode:</u> 6 litres (10.5 pints) recommended max. 80 litres/hr (141 pints/hr)

4.2. EXTERNAL ARRANGEMENT:



No.	Description	No.	Description
1	Cup Rail Acrylic QB2 Twin - (1801511)	7	Drip Tray
2	Plastic Fascia QBT2 (Twin) - (1801570)	8	Curved Splashback
3	Basket Complete QB2 - (2300085)	9	Plastic Rose MB2T/QBT2 - (1801560)
4	Control Panel Left	10	Front Panel
5	Coffee Tap - (2100290)	11	Control Panel Right
6	Hot Water Tap - (2100275)	12	Urn Lid - (2300350)

4.3. ACCESS TO INTERNAL COMPONENTS:

To access the internal components:

- Disconnect the machine from the electrical supply.
- Allow to cool sufficiently.
- Remove the screw from under each of the Plastic Roses (9 above). Slide the roses towards the tap.
- Remove the Curved Splashback (8 above) by pulling out the top edge first.
- Remove the two screws attaching each side of the front panel to the surround. (13 right). Slide the front panel down. Lever the top of the front panel away from the plastics. Lift the Front Panel away. All the internal components are now accessible.

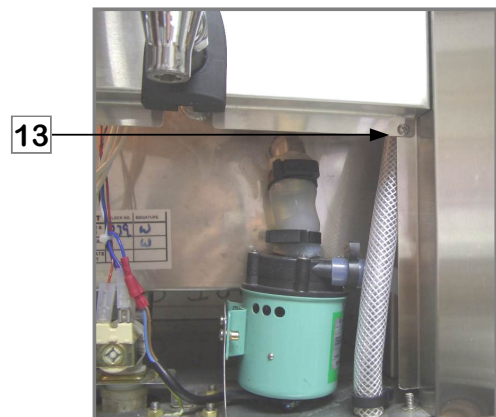

4.4. INTERNAL ARRANGEMENT:



No.	Description	No.	Description
1	PCB Brewer Display Left - 1600324	11	PCB Brewer 2004 - (1600326)
2	Sightglass Qwikbrew - (1700260)	12	PCB Dual Timer - (1600323)
3	Connector Blocks	13	PCB Daughter - (1600317)
4	Elements - (1500975)	14	Drain Pipe
5	Tank Overflow Pipe	15	Inlet Solenoid Valve - (1502170)
6	Mains Cable	16	Right Brew Pump - (1501540)
7	Left Brew Pump - (1501540)		
8	Top Tray (Brew) Overflow pipe		
9	PCB Brewer Display Right- 1600324		
10	Low, Brew and High Level Probe Assembly		

4.5. PCBs:

4.5.1. PCB Layout:

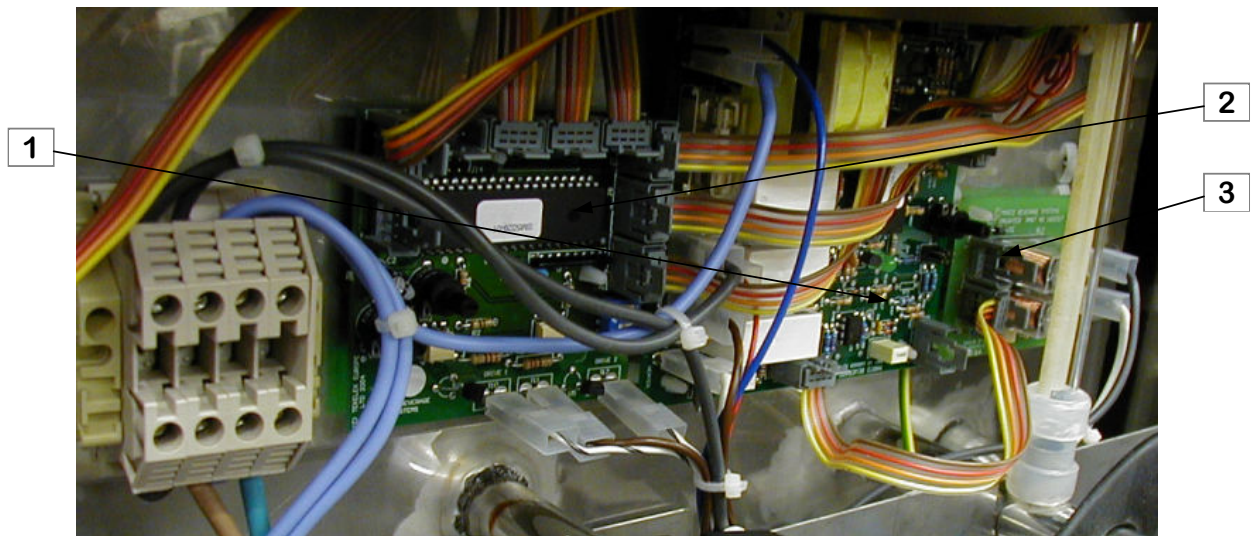

INTERNAL PCB LAYOUT:

1. PCB Brew Board (Twin 2004) (Marco part no. 1600326)
 - Controls the heater switching
 - Switches one element only (daughter PCBs switch the other elements)
 - Controls the water inlet switching
 - Controls tank temperature/temperature adjustment
 - Controls water level
 - Outputs to the Dual Timer PCB
 - Outputs to the Daughter PCBs
2. PCB Timer (Marco part no. 1600323)
 - Controls the brew pump timing
 - Controls the Display PCBs (Buttons and LEDs not shown- 1600324)
3. PCB Daughter (Marco part no. 1600317)
 - Switches one element

4.5.2. PCB Brewer 2004 (1600326):

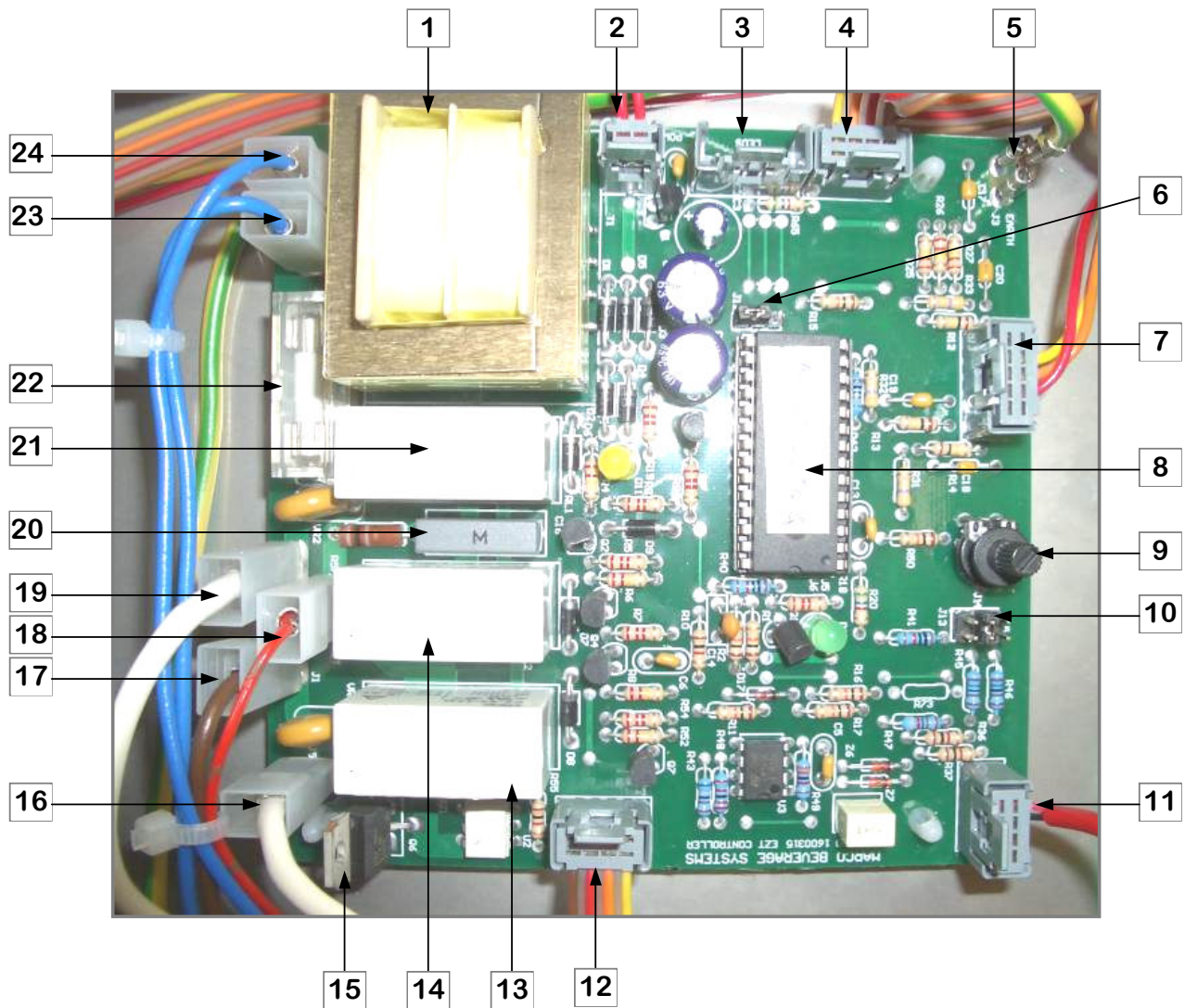

COMPONENTS OF PCB BREWER 2004:

1. Transformer
2. Power On/Off – 2way connector (low voltage)
 - Looped on this machine – power switch controlled through Display PCB and Dual Timer
3. LEDs - 5way connector (low voltage)
 - Not used on this machine
4. Data I/O – 4way (low voltage)
 - Connects to the Dual Timer PCB
5. Earth Tab
6. Mode of Operation selector – Heat Fill / Continuous Fill
 - The default position is no jumper or jumper away from the transformer side. The default mode is CONTINUOUS FILL. To change the mode to HEAT-FILL move the jumper so that the two pins nearest the transformer are connected (as shown in picture above).

7. Water Level – 5way connector (low voltage)
 - Connects to Low level, High level and Brew level probes.
8. Microchip
 - Receives inputs from Data I/O (4), Mode select jumper (6), Water Level Probes (7), Thermistor (11), Temperature Range Jumper (10), Temp adjust Pot (9) and Power On – 2way (2).
 - Outputs to Data I/O (4), LEDs (3), Daughter PCBs Connector (12), Triac(15)/Heater Relay(13)/Safety Heater Relay(14), Inlet solenoid Relay (21)
9. Temperature Adjust Pot
 - To increase temp – adjust clockwise; to decrease temp adjust anti-clockwise
10. Temperature Range Jumper
 - Controls three temperature ranges – should be on middle pins
11. Thermistor Connector
12. Daughter PCB Connector (low voltage)
 - Connects to Daughter PCBs – allows switching of more than one element
13. Relay - Heater
 - Switches the element
14. Relay - Heater Safety
 - Backup relay for element – controls the switching should the triac fail

15. Triac

- **In parallel with the heater relay. Switches the element initially. (Zero voltage switching)**
- **This lengthens the life of relays, by removing the arc (flash) during switching which wears the contacts on the relay.**

16. Heater/Element Tab (high voltage)
 - Connects to the element
17. Live Mains Tab (high voltage)
18. Inlet Solenoid Tab (high voltage)
 - Connects to the inlet solenoid
19. Live tab – spare (high voltage)
20. Suppressor
21. Relay – Inlet Solenoid
 - Switches the inlet solenoid
22. Fuse
23. Neutral Mains tab (high voltage)
24. Neutral Mains tab – spare (high voltage)

4.5.3. PCB Dual Timer (1600323):

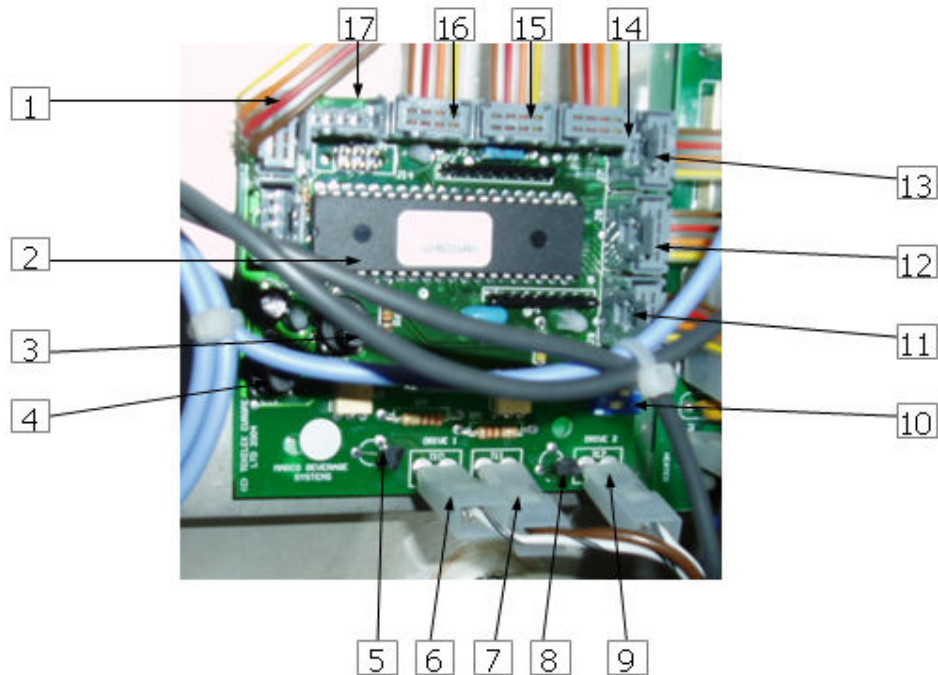

COMPONENTS OF DUAL TIMER:

1. Connector 4way (low voltage)
 - connects to Data I/O 4way connector on the Brewer PCB (see section 4.5.2)
2. Microchip
 - The version of software code is indicated when power is applied to the machine for the first time. The display PCB LEDs will flash a sequence e.g. 2 flash-pause-6flash – indicates software version 2.6
3. Right pump time adjust pot – VR2
 - turn clockwise to increase brew time on the right hand urn. Note that with the current software version, the Full brew time is double the Half brew time. Current Version 2.6
4. Left pump time adjust pot – VR1
 - turn clockwise to increase brew time on the left urn. Note that with the current software version, the Full brew time is double the Half brew time. Current Version 2.6
5. Triac - switches the left pump
6. Wire to left Pump (high voltage)
7. Live to Dual Timer (high voltage) (looped to 5)
8. Triac - switches the right pump
9. Wire to right Pump (high voltage)
10. Timer Mode select switches - only switch No.1 should be ON for this machine
11. Connector for Right Display PCB – right ribbon cable
12. Connector for Right Display PCB – middle ribbon cable
13. Connector for Right Display PCB – left ribbon cable
14. Connector for Left Display PCB – right ribbon cable
15. Connector for Left Display PCB – middle ribbon cable
16. Connector for Left Display PCB – left ribbon cable

4.5.4. PCB Daughter (1600317):

Each PCB Daughter is used to switch an element. The triac, relay and safety relay used on the PCB Brewer is also used on the PCB Daughter. This reduces wear on components.

1. Live Tab - connects to mains live
2. 4way Connector J2
 - connects to another Daughter PCB if another one used (only one Daughter PCB on 5.6Kw Qwikbrew 2 Twin)
3. 4way Connector J1
 - connects Daughter PCB to Brewer PCB
4. Heater Tab - connects to element

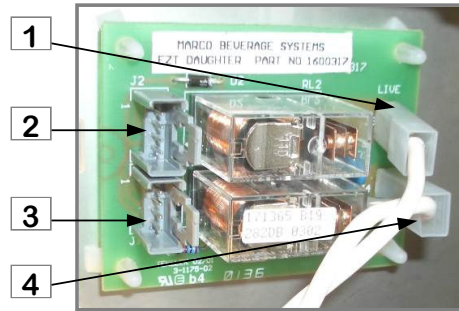

4.5.5. PCB Brewer Display (1600324):

NOTE: The Left and Right PCB Brewer Displays have the same part number, but the Right PCB needs to be modified on site before it can be installed. The Button cap needs to be removed off the second button (shown below).

Left Display PCB

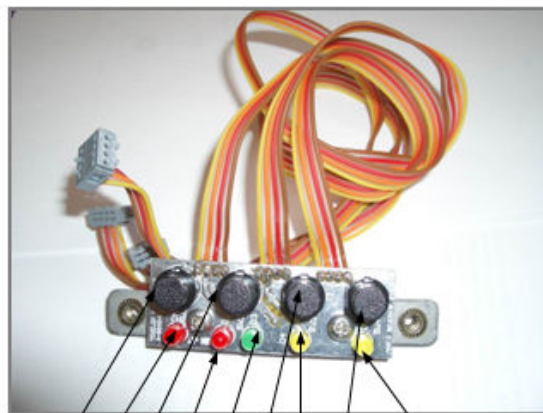

- 1
- 2
- 3
- 4
- 5
- 6
- 7
- 8
- 9

Right Display PCB

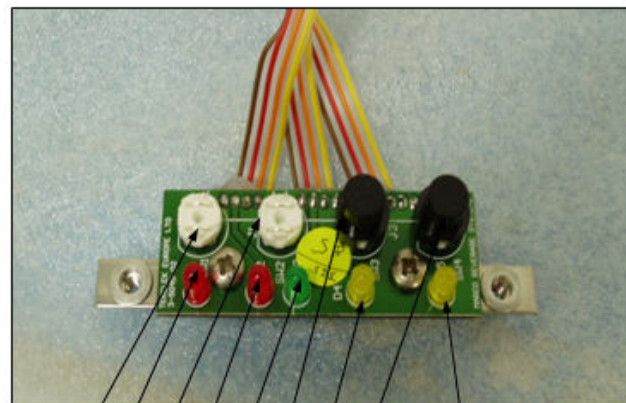

- 10
- 11
- 12
- 13
- 14
- 15
- 16
- 17
- 18

COMPONENTS/FUNCTIONS OF LEFT PCB BREWER DISPLAY

1. Button – Lock function
2. LED – Lock function
3. Button – Power ON/OFF function
4. LED – Power ON/OFF and Status (Diagnostic flash) function
5. LED – Ready to Brew function
6. Button – Left Half Brew function
7. LED – Left Half Brew function
8. Button – Left Full Brew function
9. LED – Left Full Brew function

COMPONENTS/FUNCTIONS OF RIGHT PCB BREWER DISPLAY

10. Button – Not Used (Button cap to be removed)
11. LED – Not Used
12. Button – Not Used (Button cap to be removed)
13. LED – Not Used
14. LED – Ready to Brew function
15. Button – Right Half Brew function
16. LED – Right Half Brew function
17. Button – Right Full Brew function
18. LED – Right Full Brew function

4.6. OPERATION – HEAT FILL MODE (Non-Standard):

NOTE: The standard operation mode for this machine is the Continuous Fill cycle. The Continuous Fill cycle can be selected by moving the Jumper J12 on the Brewer PCB (above the microchip) to the position nearest the transformer. See

Turn the water on at the stop valve and switch the power on at the wall connection. Press the POWER ON button at the front of the machine. A red LED next to the button will illuminate and the machine will start to fill. This LED will flash a 2 flash cycle while the water level is below the low level probe.

Note: The machine will not heat until the water has reached the low level probe.

When the low-level probe is reached, the water inlet is stopped and the element is switched on. This water is heated to the pre-set temperature (92– 94.5°C). The machine takes in another small body of water, while continuing to heat. This method of staggered filling (heat-fill cycle) ensures that the temperature in the tank remains within 3 degrees of set temperature. This heat-fill cycle continues until:

- a) the water level reaches the high level probe and
- b) the water temperature reaches the pre-set temperature as above.

Note: When the level of water is at a safe height above the low level, the green READY TO BREW light illuminates. This indicates that the machine has enough water to run a brew and is at the correct temperature. The machine is NOT full at this level and will continue to fill. A brew can be selected at this point Unless a brew is selected, the full quantity of hot water should be available within 15 minutes of reaching this level.

The machine is ready to brew Coffee and up to 15 litres of Hot Water is available for immediate draw-off when the machine is full and up to temperature.

There is one large water tank, with two urns recessed into it. When a brew is selected, hot water is pumped from the tank up to a sprayhead and into the filter basket. The coffee runs out of the filter basket into the urn. Since the water tank surrounds the urn, the brewed coffee is kept at temperature.

The heat fill cycle ensures that the temperature in the tank does not drop by more than 3 degrees. The machine will only allow small amounts of cold water into the tank, while continuing to heat to ensure that the temperature does not drop too low. If more hot water is used than the machine can recover (approx 0.85 L/min @ 5.6 kW), the amount of water in the tank decreases. If the full quantity of Hot Water is drawn off, the machine will take approximately 15min to recover back up to the high level probe.

When two brews are running simultaneously, the level of the water in the tank does drop slowly, because the machine is using water at a quicker rate than it can heat. If dual brews are selected at a point where the level of water will drop off the BREW SAFETY LEVEL PROBE, the current brews will be completed, but a recovery period will be necessary before new brews can be selected. After a recovery period (up to 15 mins), the machine will be ready to brew once again.

In the HEAT-FILL mode drawing off Hot Water while brewing Coffee should not affect the quality of the brew. The machine naturally gives priority to the coffee. The machine will effectively run out of hot water (no water will be available out of the hot water tap), but brews will still be finished.

4.7. OPERATION – CONTINUOUS FILL MODE (Standard):

Turn the water on at the stop valve and switch the power on at the wall connection. Press the POWER ON button at the front of the machine. A red LED next to the button will illuminate and the machine will start to fill.

Note: The machine will not heat until the water has reached the low level probe. When the water level is below the low probe, the Power LED flashes the diagnostic 2 flash cycle.

When the low-level probe is reached the element is switched on. The machine continues to fill until the high level probe is reached.

This means that the machine is full of cold water at this point. The water is heated to the pre-set temperature (92– 94.5°C). The continuous fill cycle is complete when the green Ready to Brew light is on. A brew can now be selected.

Note: Once again – the Green ‘Ready to Brew’ light indicates that the machine is at a safe level and up to temperature, but in this case the water has filled to the high probe already, so the machine will be full and up to temperature when the light comes on for the first time.

Unlike the Heat-Fill mode, the machine will fill with mains water as soon as the water level drops off the high level probe. The machine will always be full of water, but the drawback is that if operators draw off too much water from the hot water tap, the temperature of the beverages can be affected. The brew temperature will not drop significantly while brewing, even when doing dual brews – BUT - if a large amount of hot water is used at the same time, brew temperatures can be affected, because cold mains water replaces the hot water used immediately.

4.8. TROUBLESHOOTING – DIAGNOSTIC GUIDE:

The Marco Qwikbrew 2 Twin uses an electronic diagnostic system to help determine faults.

If an error is detected a sequence of flashes is displayed through the POWER light – shown in the picture below.



The length of time and recovery method of each of these flashing displays is detailed below:

2 FLASH CYCLE – BELOW LOW LEVEL

Display pattern:

- 2 quick flashes then a short pause - repeated.

Electronic check and action:

- This indicates that the low level circuit is open i.e. the probe is not in contact with the water.
- The element is switched OFF at this stage and the inlet is left ON. (note that if this is a low probe wiring fault, the water will stop at the high level probe regardless of the status of the low level).
- This is a recoverable error i.e. the machine does not need to be reset when the problem is solved. (e.g. if a closed mains water stop valve is the problem, opening the valve will allow water into the machine and normal function will resume when the low level probe is reached)

Probable causes:

1. The water level is below the low level probe, which is normal when the machine fills for the first time. (Can be flashing for up to 5 mins at start up)
2. The low level probe wire is disconnected, or there is another wiring fault (eg. a bad earth (return) connection between the PCB and the Tank)

Action required:

1. Check that the water pressure is OK and ensure that the stop valve is open.
2. Check that the inlet solenoid is working.
3. If the water level is above the level of the low probe, check the probe circuit wiring

3 FLASH CYCLE – THERMISTOR OPEN CIRCUIT

Display pattern:

- 3 quick flashes then a long delay (up to 15 seconds) - repeated.

Electronic check:

- This indicates that the Thermistor is measuring such a large resistance that it assumes the thermistor circuit is open.
- The element and inlet valve are turned OFF when this error is detected
- This is a recoverable error. When the correct range of resistance is measured, normal operation resumes

Probable causes:

1. The thermistor probe is unplugged from the 4way connector on the PCB or the thermistor has failed open circuit.

Action required:

1. Check that the thermistor is plugged in to the PCB correctly. If it is, replace the thermistor.

4 FLASH CYCLE (Heat Fill Mode Only) – NOT HEATING

Display pattern:

- 4 quick flashes then a short pause - repeated.

Electronic check:

- This checks that the temperature is increasing when the heater is on.
- Measures the rate that the temperature increases in a specified time. This error is only displayed after 20 mins of the heater being on continuously. When the error is detected, the element and inlet valve are turned off.
- This is a non recoverable error. The machine needs to be reset when this problem is solved.

Probable causes:

1. All the elements have failed
2. Wiring fault

Action required:

1. Check that the resistance on the elements. If there is a reasonable resistance (15-25 Ω) on the element it probably has not failed, so the wiring might be at fault. NOTE: for this error to be displayed all elements would have to fail.

5 FLASH CYCLE – THERMISTOR SHORT CIRCUIT

Display pattern:

- 5 quick flashes then a short pause - repeated.

Electronic check:

- This indicates that the Thermistor is measuring zero resistance. It assumes the thermistor has failed sort circuit.
- The element and inlet valve are turned OFF when this error is detected
- This is a recoverable error. When the correct range of resistance is measured, normal operation resumes.

Probable causes:

2. The thermistor has failed.

Action required:

2. Replace the thermistor.

6 FLASH CYCLE (Heat Fill Mode Only) – NOT FILLING

Display pattern:

- 6 quick flashes then a short pause - repeated for approx 2min. Then normal function resumes for 1min30secs – then flashes for 2min again – this cycle is repeated.

Electronic check:

- This checks that the inlet solenoid valve is not kept ON for more than 1min30secs when in the heat fill cycle. Note: this error is only checked

once the water level has reached the low level probe and the machine has begun the heat fill cycle.

- This is a recoverable error. In the heat fill cycle, even with reasonably low water pressure the inlet solenoid valve usually only stays ON for approx 5-6 seconds. If the inlet valve stay ON for more than 1min 30secs, there is a problem with the inlet valve or the mains water supply. After 1min30seconds the 6 flash cycle is displayed for 2 mins – the inlet solenoid valve is turned OFF during this time. After this 2 min cycle, normal operation resumes i.e. the machine attempts to fill by opening the inlet solenoid valve once more. If after 1min30secs no water has come into the machine, the 6flash sequence is displayed again. This cycle is repeated.

Probable causes:

1. Mains water pressure problem or the mains water stop valve is closed.
2. Inlet solenoid valve failure.

Action required:

1. Check the mains water supply. If it is good, wait 5minutes to check that the error cycle is continuing.
2. If the mains water supply is good, check that the inlet solenoid valve is working.

4.9. Level Probes

The level probes provide much of the control inputs into the PCB and are critical to the operation of the machine. The wiring to these should be checked regularly and the probes themselves should be cleaned whenever the machine is serviced.

There are 3 level probes on the Qwikbrew 2 Twin.

- Low Level Probe
- High Level Probe
- Brew Level Probe

All the probes are mounted on one assembly on the top right side of the tank. The pictures below show how to remove this assembly:

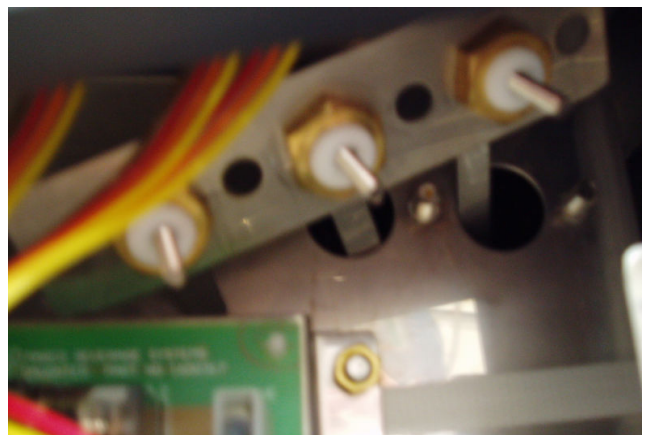
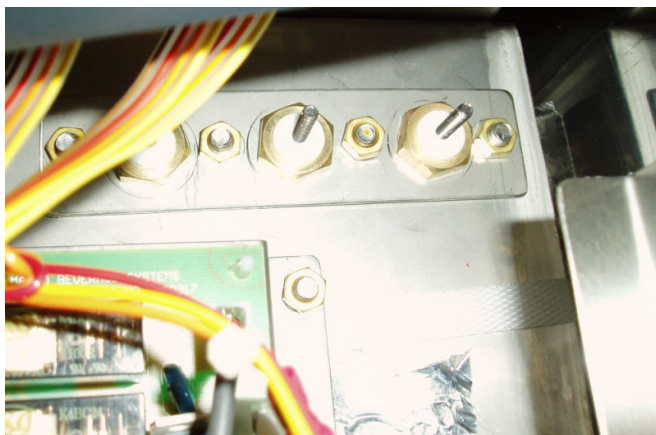

The Level Probe assembly is shown in the picture.

The probes are mounted above the water line and have stainless steel tabs that hang down to the level required.

Level Probe Assembly (in picture on right):

- The low level probe has the longest tab - 210mm. When in position, the bottom of the tab rests in a safe position above the elements
- The brew level probe has a 140mm long tab. A brew can be selected and will complete safely when the water level has reached this probe. A brew cannot be selected below this level.
- The high level probe has the shortest tab – 40mm.

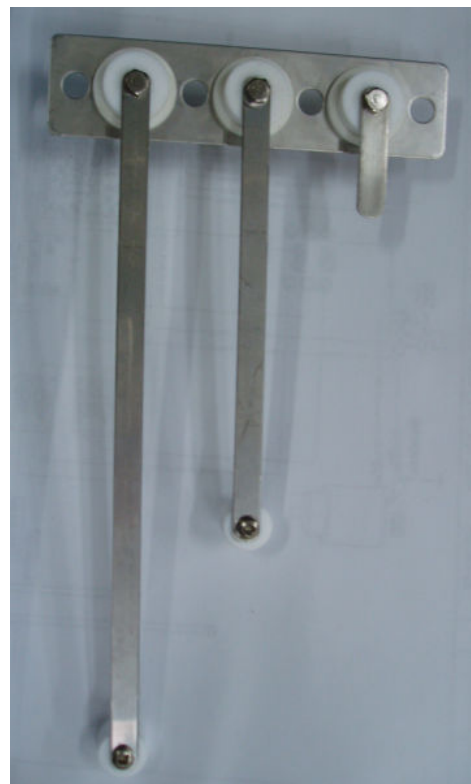

4.10. Elements

Removing the elements:

- Drain the machine:
 - remove the top hoseclip off the drain hose loop (1 in picture below)
 - carefully pull the hose off the top elbow
 - squeeze the silicon hose near the bottom and quickly pull the upper part of the hose out from the machine and place in the drain facility
- Remove the element assembly/clean out door (2 in picture below) by unfastening the 8 brass nuts. Slide the element assembly through the clean out opening.

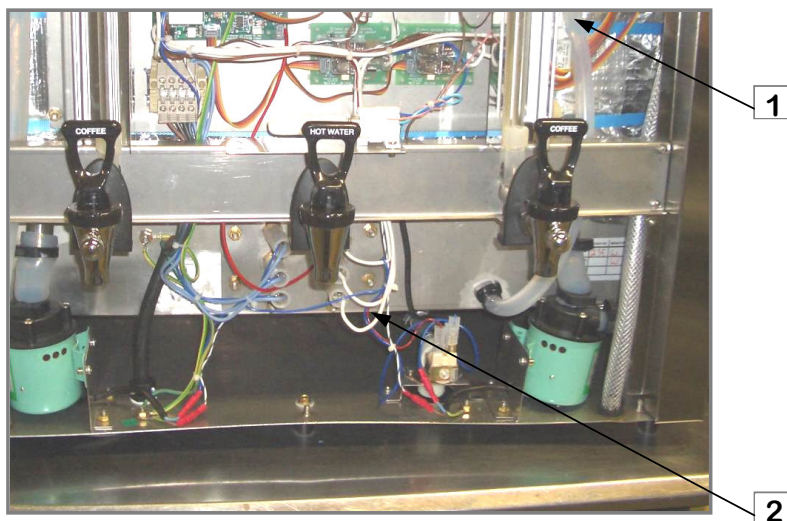

The element assembly consists of two 2.8kW 230V elements attached to the stainless steel clean out door (see below). The thermistor pocket is welded into the clean out door. When reassembling the clean out door/ element assembly ensure that the red

silicon o-ring is not damaged and the tank is well sealed. Check this carefully while the machine is heating up.

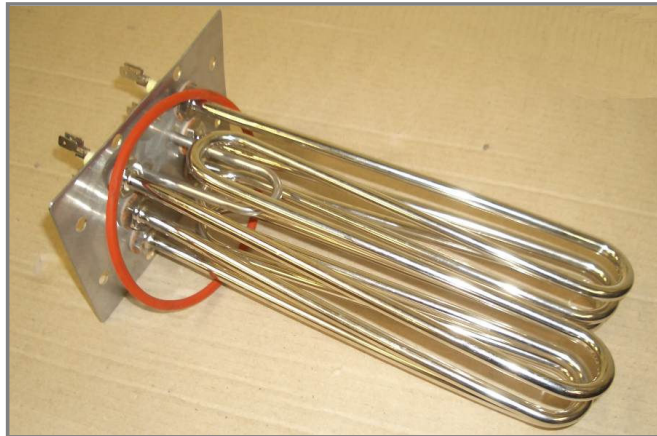

4.11. Descaling Procedure

To descale the machine thoroughly:

- Follow the instructions for removing the elements
- Attempt to remove as much scale as possible by hand, through the clean out door (see below). Note: ensure that internal components are protected if a hose is going to be used to flush the tank.

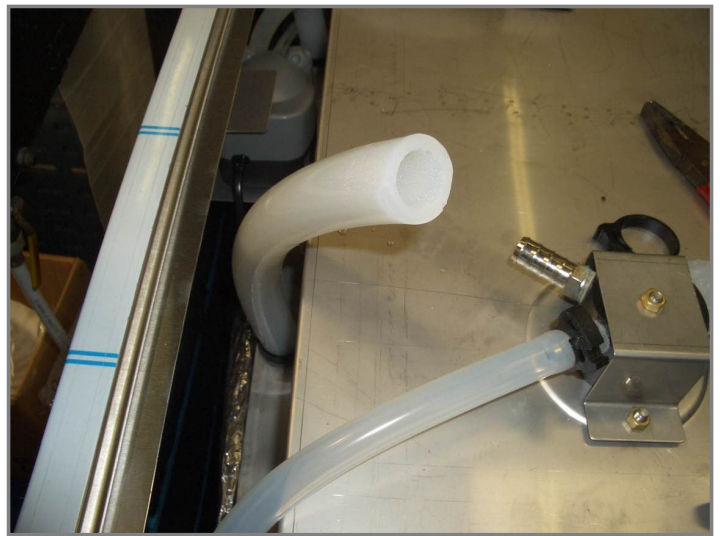
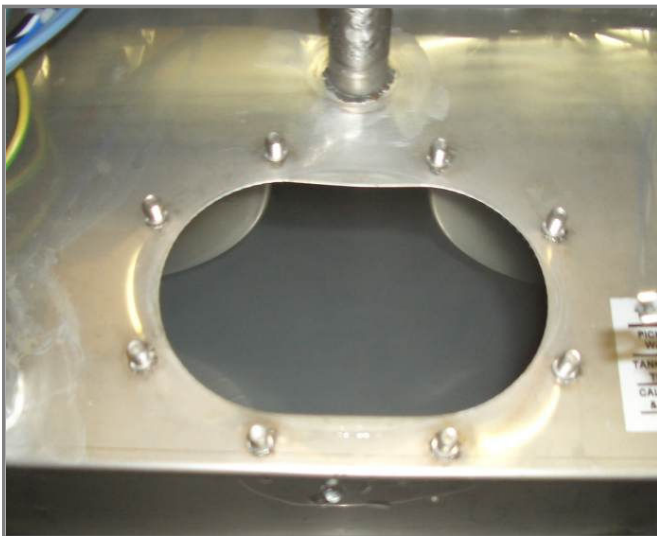

- Replace the element assembly and switch on the machine.
- Remove the cup rail and lid of the machine. Add a descale solution to the tank through the large sprayhead hose (shown below). This runs directly into the top of the tank.
- Wait 20 minutes before draining and flushing the tank again.

4.13. Wiring Diagram

Marcco Beverage Systems	Description: WIRING DIAGRAM	Drwg No: QB2T-001A	Tol: +/- 10mm	Drawn: AD	c	Wire Change	06/09/05
Model: 1000495 QWIKBREW 2 TWIN 1 PH		Part No:	Scale: NTS	Date: 15/04/05	b	New Drawing	10/3/05
		Bend Progi:	P/ch Progi:	Approv:		Rev. Details	Date

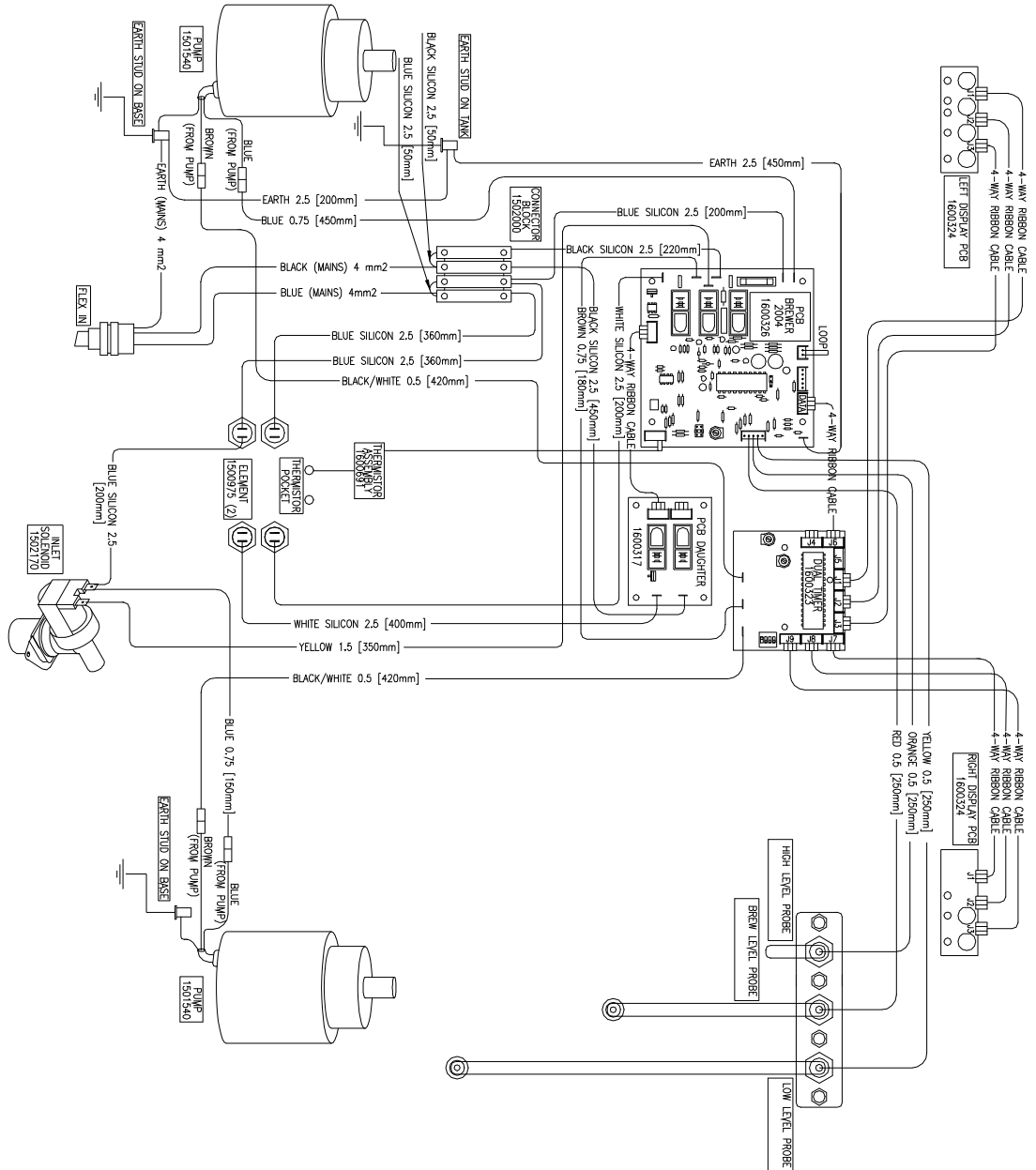

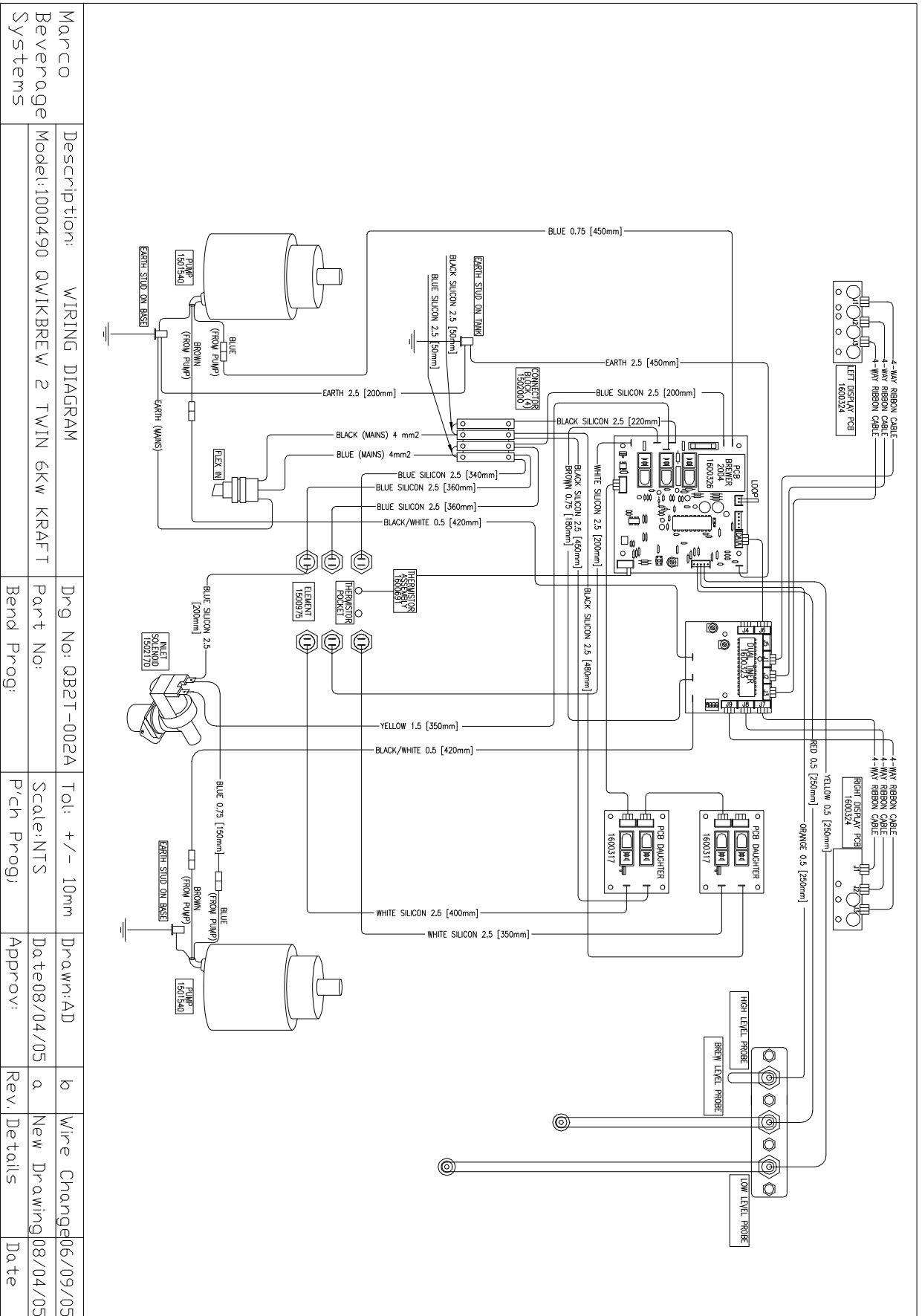

MARCO Beverage Systems Description: WIRING DIAGRAM	Model: 1000490 QWIKBREW 2 TWIN 6KW KRAFT	Drg No: QB2T-002A	Part No:	Scale: NTS	Date: 08/04/05	Wire Change: b	Date: 08/04/05
	Bend Prog:	P'ch Prog:	Tol: +/- 10mm	Drawn: AD	Rev. a	New Drawing	Details

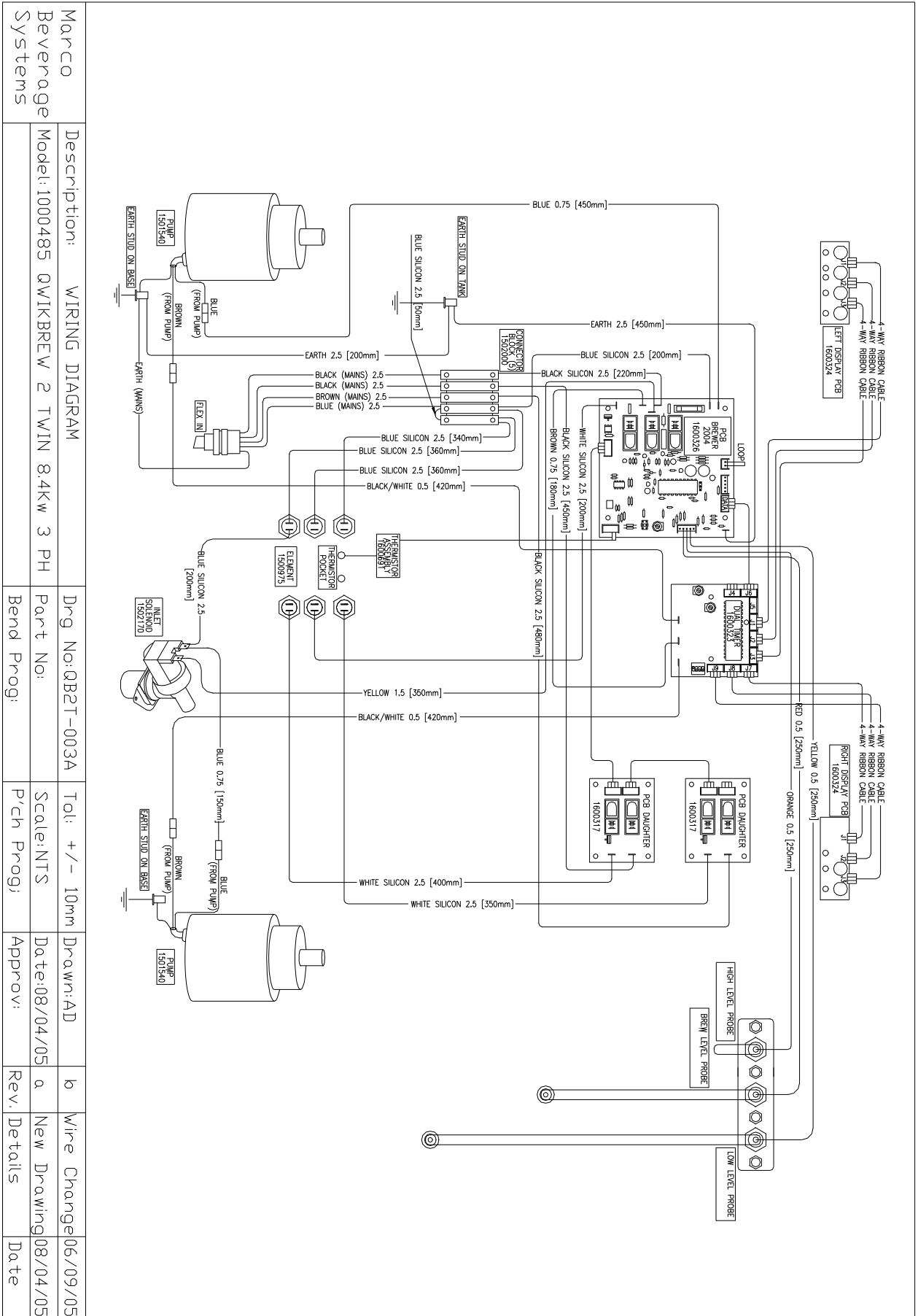

Marco Beverage Systems	Description: WIRING DIAGRAM	Part No:	Tol: +/- 10mm	Drawn: AD	Rev. Details	Wire Change: 06/09/05
Model: 1000485 QWIKBREW 2 TWIN 8.4kW 3 PH	Part No:	Scale: NTS	Date: 08/04/05	Rev. a	New Drawing	08/04/05
	Bend Prog:	P'ch Prog:	Approv:			Date

4. Technical Data:

4.14. Spare Parts List

Part Number	Description
1600326	PCB Brewer 2004
1600323	PCB Timer Dual 2004
1600317	PCB Daughter
1600324	PCB Brewer Display
1501540	Pump Nikkiso
1502170	Valve Inlet Solenoid
1600691	Thermistor Assembly
1500975	Element 2.8kW 230V (m-shape)
2301300	High Level Probe Assembly
2301326	Low Level Probe Assembly
2301304	Brew Level Probe Assembly
2100275	Hot Water Tap (with chrome body)
2100290	Coffee Tap (with chrome body)
2100155	Tap Assembly – Hot Water
2100185	Tap Assembly - Coffee
1401170	Nut Chromed for Tap
1400550	Circlip for Tap
1700260	Sightglass
1801560	Plastic Rose (around Tap)
1801570	Plastic Fascia MB2T
2300085	Basket Complete MB2
2300350	Urn Lid Complete
2300175	Drip Tray Complete Qwikbrew 2 Twin
8000240	Urn Cleanser (800g Tub)
1801511	Cup Rail Acrylic

**MARCO is an
ISO9001:2000
Registered
Company.**

