

Technical information and Installation Servicing Instructions

TURBO Oil Boiler.....



Model

- * TURBO - 17 (19.8 kW)
- * TURBO - 21 (24.4 kW)
- * TURBO - 25 (29.1 kW)
- * TURBO - 30 (34.9 kW)

CE PC M K ISO 9001 ISO 14001

CONTENTS

1) overall view		
1 -1. General information	*****	3
2) Product description		
2 - 1. Boiler Specification	*****	4
2 - 2. Product dimensions	*****	5
2 - 3. Burner Specification	*****	6
3) Installation		
3 - 1. Standard chimney installation	*****	9
3 - 2. Standard heating & hot water installation	*****	11
3 - 3. Standard gas connection installation	*****	14
3 - 4. Burner connection spec	*****	15
3 - 5. connecting Electricity	*****	16
4) Main part spec		
4 - 1. Gear pump	*****	17
4 - 2. Electronic pump	*****	17
4 - 3. Ignition transformer	*****	19
4 - 4. Connector	*****	19
4 - 5. Ignition bar	*****	20
4 - 4. Adjustment and gas conversion	*****	21
5) Burner direction for assembly		
5 - 1. Burner part exploded view	*****	22
6) Test working		
6 - 1. Check list before switching - on	*****	24
7) Direction for assembly		
7 - 1. Boiler part exploded view	*****	25
7 - 2. Part name	*****	26
8) Maintenance guide		
8 - 1. Assembly of Burner	*****	27
8 - 2. Assembly of Temp. and Overheating Sensors	*****	28
8 - 3. How to clean Heat exchanger's Exhaust tube	*****	29
9) Function of the controller		
9 - 1. Main controller part name	*****	30
9 - 2. Room control part name (CTR-5700 plus)	*****	31
9 - 3. Room control LED panel	*****	32
10) Troubleshooting guide (error code)		
10 - 1. Finding failure	*****	33
11) Technical Data Table	*****	34
10) Memo	*****	35
11) Warranty	*****	36

1. overall view

1 - 1 General Information

These instructions are suitable for **TURBO** Series standing Oil boiler;

Do not forget this instruction.

To ensure the correct installation, commissioning and servicing of domestic central heating system.

1. High efficient Heat Exchanger

It's a boiler with high efficiency and low noise, which exchanges the heat efficiently and has a tolerance to the strong headwind in winter.

2. Electronic Automatic Control Device (Korea Patent No.17570)

Electronic Automatic Control Device(CTC) judges the operation status of boiler and controls it. CTC is the high-tech controller with the program for self-diagnosis function, automatic control function, Hot water-only mode, Sleep mode and Out of house mode.

3. Cutting edge self-diagnosis System

It has the various and convenient fuel-saving mode such as Outgoing, Bath and Sleep mode, and is equipped with the safety devices including a flame sensor and a temperature sensor. It's a safe boiler with the cutting edge technology.

4. Turbo Cyclone Burner (Korea Patent No.101040)

Kiturami Turbo Cyclone Burner burns combusted air secondarily with a special metal plate heated up to 800°C like a turbo engine of an automobile. It's different from general burner which burns injected fuel from nozzle in the air. It's eco-friendly and acquires NT(Net Technology). Turbo Cyclone Burner guarantees environment-friendliness, safety and long-life.

It's a hydraulic spray type burner, which can use the oil or the diesel variously, and adapt to solidified oil under sub-zero Temp. and combustion conditions change

5. Slim design for easy installation

It's easy to transport and install in a small space by the optimal design with the cutting edge 3-dimensional design technique.

2. Product description

2 - 1 Boiler Specification

Model : TURBO Oil Boiler

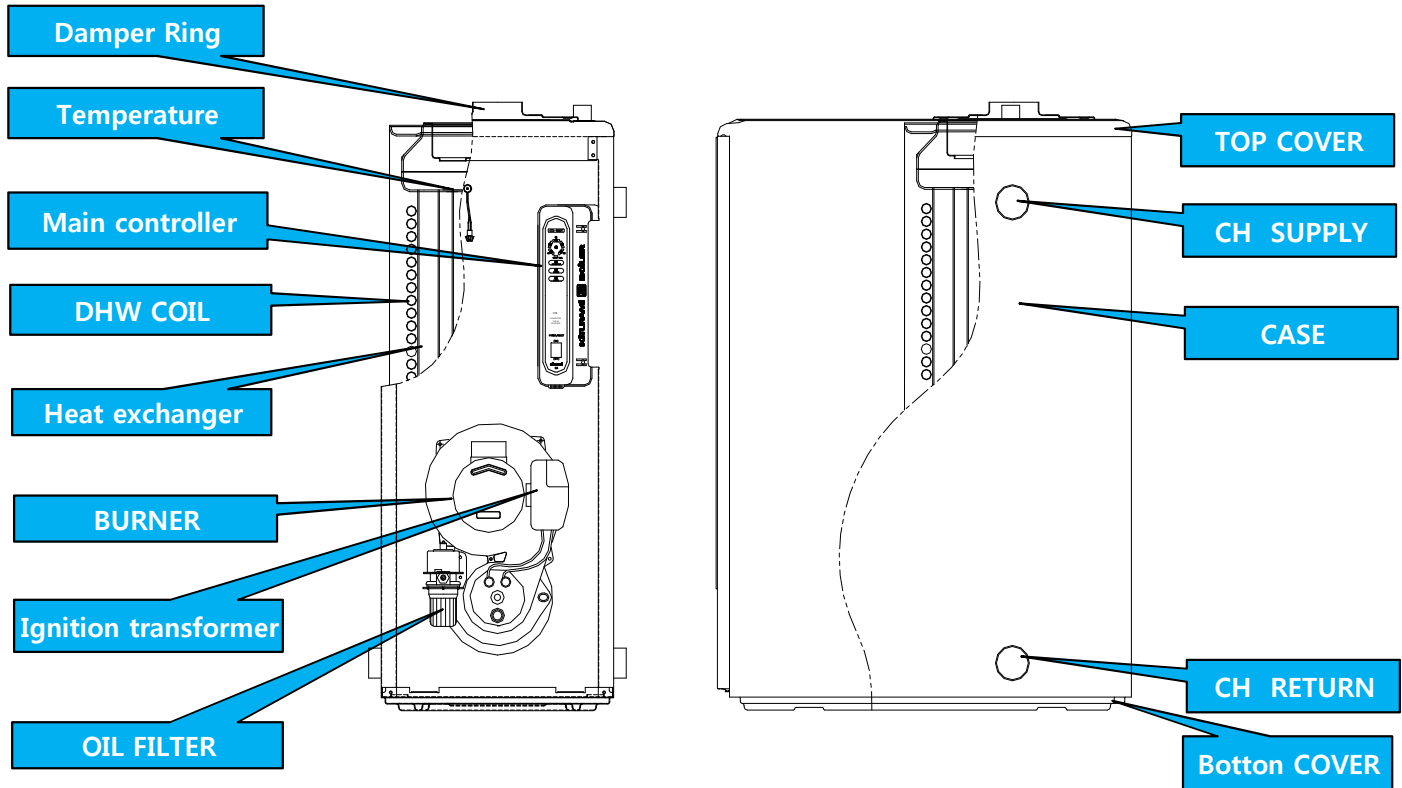

MODEL	TURBO-17	TURBO-21	TURBO-25	TURBO-30
POWER SOURCE	220 V/50Hz			
DIMENSION (Wx Dx H)	325 x 602 x 815		365 x 650 x 890	
WEIGHT (kg)	150	160	220	350
INSTALLATION TYPE	FE			
FUEL TYPE	Light Oil			
HETING AREA (m ²)	113	140	166	200



Room Control



FLUE



STAINLESS BAND

2 - 2 Product dimensions

▶ TURBO - 17 , 21 , 25 , 30

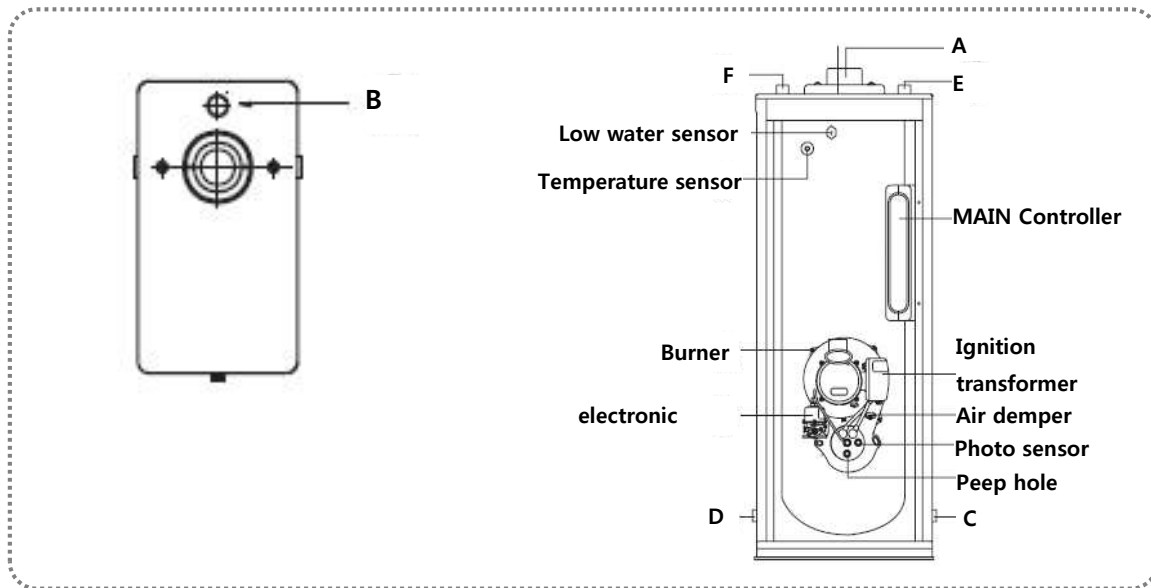

A : Flue Connector B: CH Supply
E : DHW inlet

C: CH Return
F: DHW outlet

D: Drain

▶ Dimension of Boiler

mm

MODEL	W	L	H
TURBO - 17	325	602	815
TURBO - 21	325	603	815
TURBO - 25	365	650	890
TURBO - 30	365	650	890

▶ Pipe Size

mm

MODEL	A	B	C	D	E	F	REMARK
TURBO - 17	80	32	32	32	15	15	
TURBO - 21	80	32	32	32	15	15	
TURBO - 25	80	32	32	32	15	15	
TURBO - 30	80	32	32	32	15	15	

※ CH supply pipe is on the upper section as shown in Figure.

2 - 3 Burner Specification

* BURNER MODEL : TURBO - 17 (19.8kW)
TURBO - 25 (29.0kW)

, TURBO - 21 (24.4kW)
, TURBO - 30 (34.9kW)

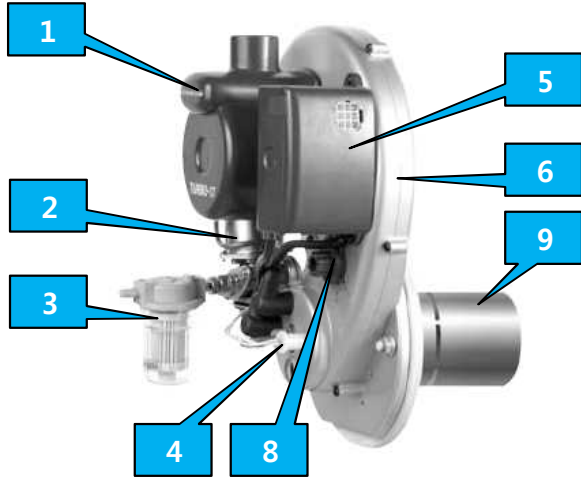

Electronic Pump type

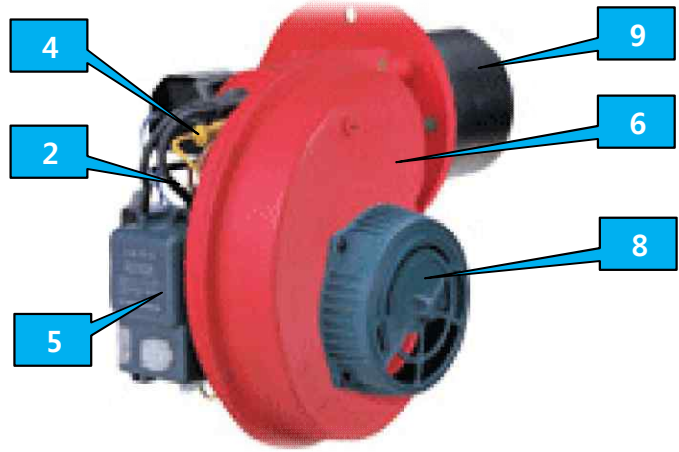

Gear Pump type

NO	NAME	NO	NAME	NO	NAME
1	Motor cover	2	Electronic, Gear Pump	3	Oil filter
4	Photo sensor	5	Ignition transformer	6	Burner Body
7	Burner Gasket	8	Air Damper	9	Burner Tube
Remark					

※ Features of Turbo Cyclone Burner

Kiturami Turbo Cyclone Burner burns combusted air secondarily with a special metal plate heated up to 800°C like a turbo engine of an automobile, considerably reducing fuel costs and exhausts.

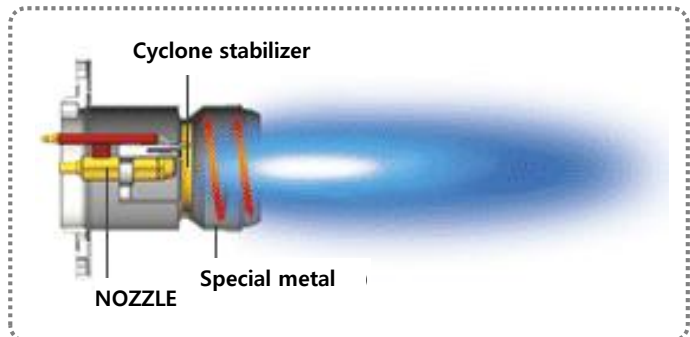

* Dimension of Electronic Pump type Burner

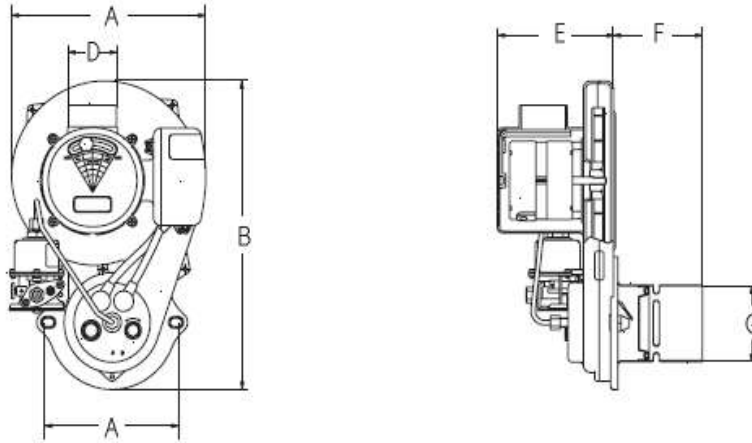

mm

MODEL	A	B	C	D	E	F	G
TURBO- 9	144	334	219	53	131	100	83
TURBO-13	144	334	219	53	131	100	83
TURBO-17	144	334	219	53	131	100	83
TURBO-21	144	334	219	53	131	100	83

* Dimension of Gear Pump type Burner

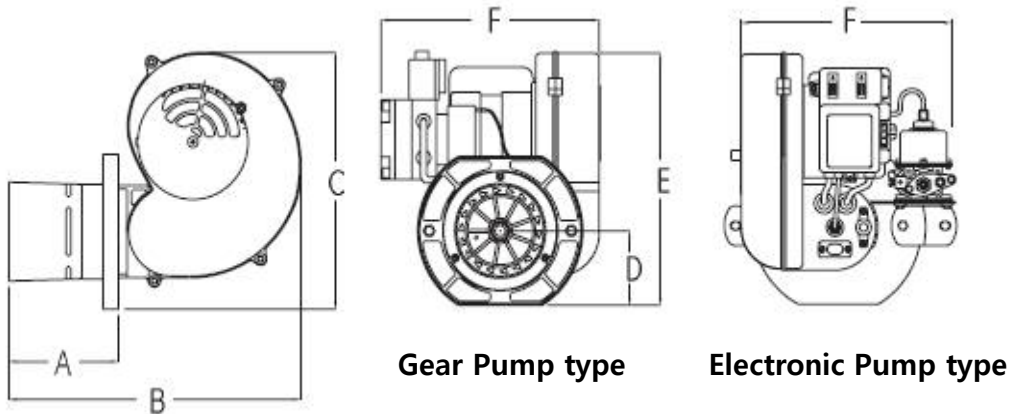

Gear Pump type

Electronic Pump type

MODEL		A	B	C	D	E	F
TURBO- 21		110	290.0	250.0	78.0	250.0	234.0
TURBO-25	Gear Pump type	110	290.0	250.0	78.0	250.0	234.0
	-	-	-	-	-	-	-
TURBO-30	Gear Pump type	110	290.0	250.0	78.0	250.0	234.0
	-	-	-	-	-	-	-
TURBO-35	Gear Pump type	110	290.0	250.0	78.0	250.0	234.0
	-	-	-	-	-	-	-

*** Dimension of Electronic Pump type Burner Flange**

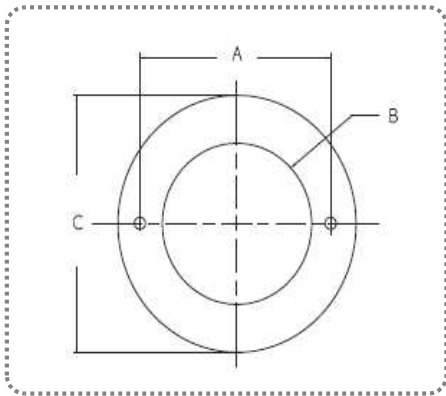

mm			
MODEL	A	B	C
TURBO-17	143.5	115	172
TURBO-21	143.5	115	172

*** Dimension of Gear Pump type Burner Flange**

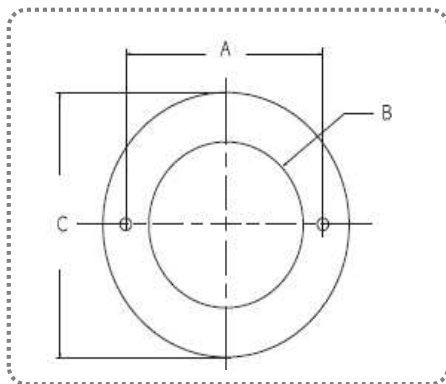

mm			
MODEL	A	B	C
TURBO-21	143.5	115	172
TURBO-25	143.5	115	172
TURBO-35	143.5	115	172

3. Installation

3-1 Standard chimney installation

► Installing flue in case of no existing flue

1. As shown in Figure 1-1, install stainless flue outside and then install air intake vent and exhaust gas vent for boiler room.
2. Cover the Flue and the surface of the wall with the nonflammable material to prevent fire or damage by high temperature of exhaust gas.
3. Install the flue part connected with exhaust hood should be installed longer than 50cm, which prevents condensate from flowing into the inside of boiler.
4. Install the condensate drain at "A" region to prevent the condensate, generated in the outer flue, from flowing into the inside of boiler.

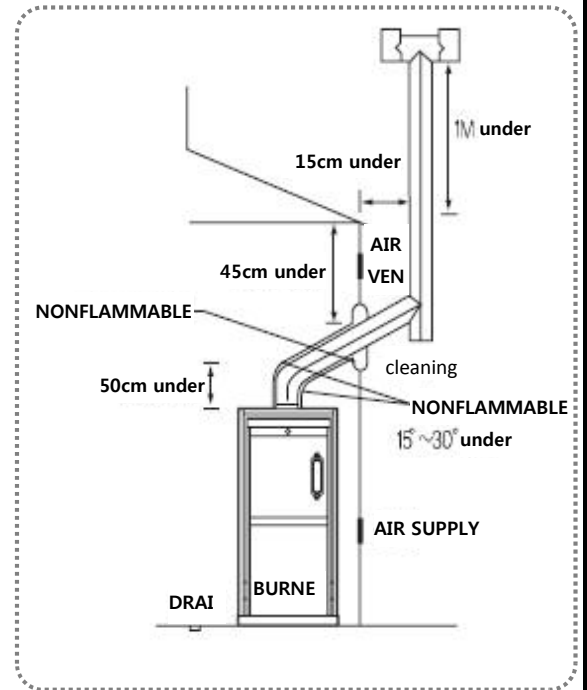

► Installing flue in case of existing flue

1. Check the air leakage at the joint between outer flue and inner flue, and seal the joint with the nonflammable material.
2. Install air intake vent at the bottom and exhaust gas vent at the top.
3. Keep the distance more than 200mm between flue's end, which smoothes the emission of exl
4. Install the condensate drain to discharge the condensate, generated in the outer flue.

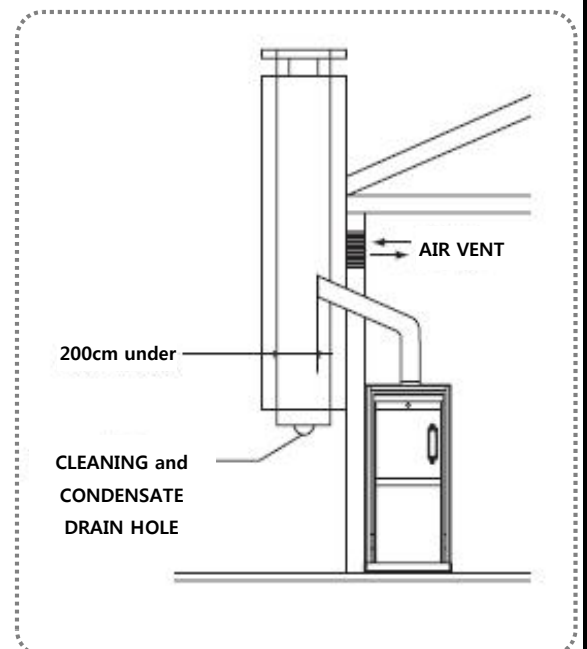

▶ Installing the Boiler

1. Do not install the boiler in tightly shut area without ventilation or in bathroom with a lot of moisture. It may cause the critical lack of oxygen or imperfect combustion.
2. Install the boiler horizontally and solidly on the nonflammables such as concrete or bricks which can withstand the weight.
3. Do not install the boiler in open veranda or outdoor for the frost protection.
4. Place the boiler in the area with enough space to check and repair it.
5. Use a plug acceptable only for the boiler.
6. Install the boiler 50mm higher than the floor.

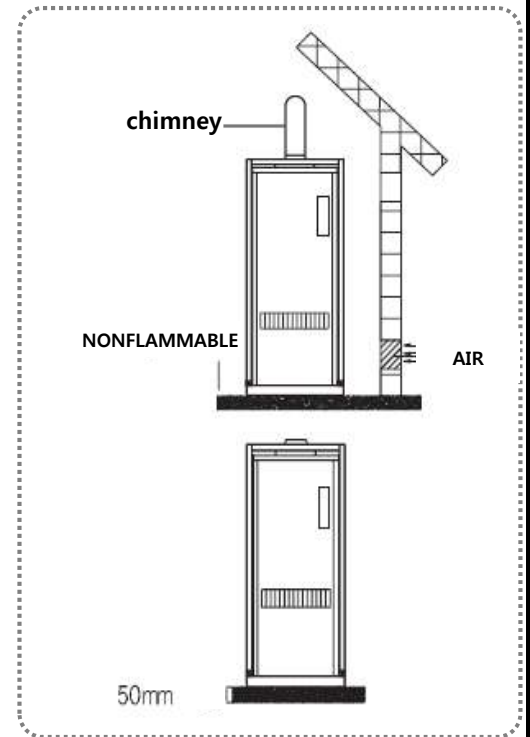

▶ Cautions in installing Flue

1. The highest part of flue should be out of wind pressure belt and not be influenced by rain and wind.
2. When there is a high building or an obstacle within 1M around the flue, the flue should be Min. 1M higher than the high building.
3. If the flue is placed in a wind pressure belt, the efficiency of the boiler is getting lower because the imperfect combustion causes soot, and that leads to safety shut down function, which means the boiler does not work well.

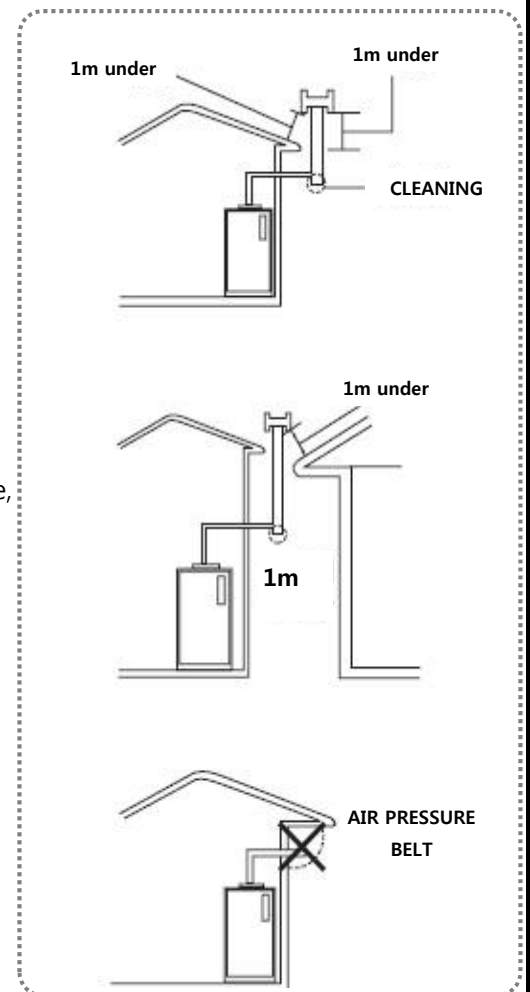

3 - 2 Standard heating & hot water installation

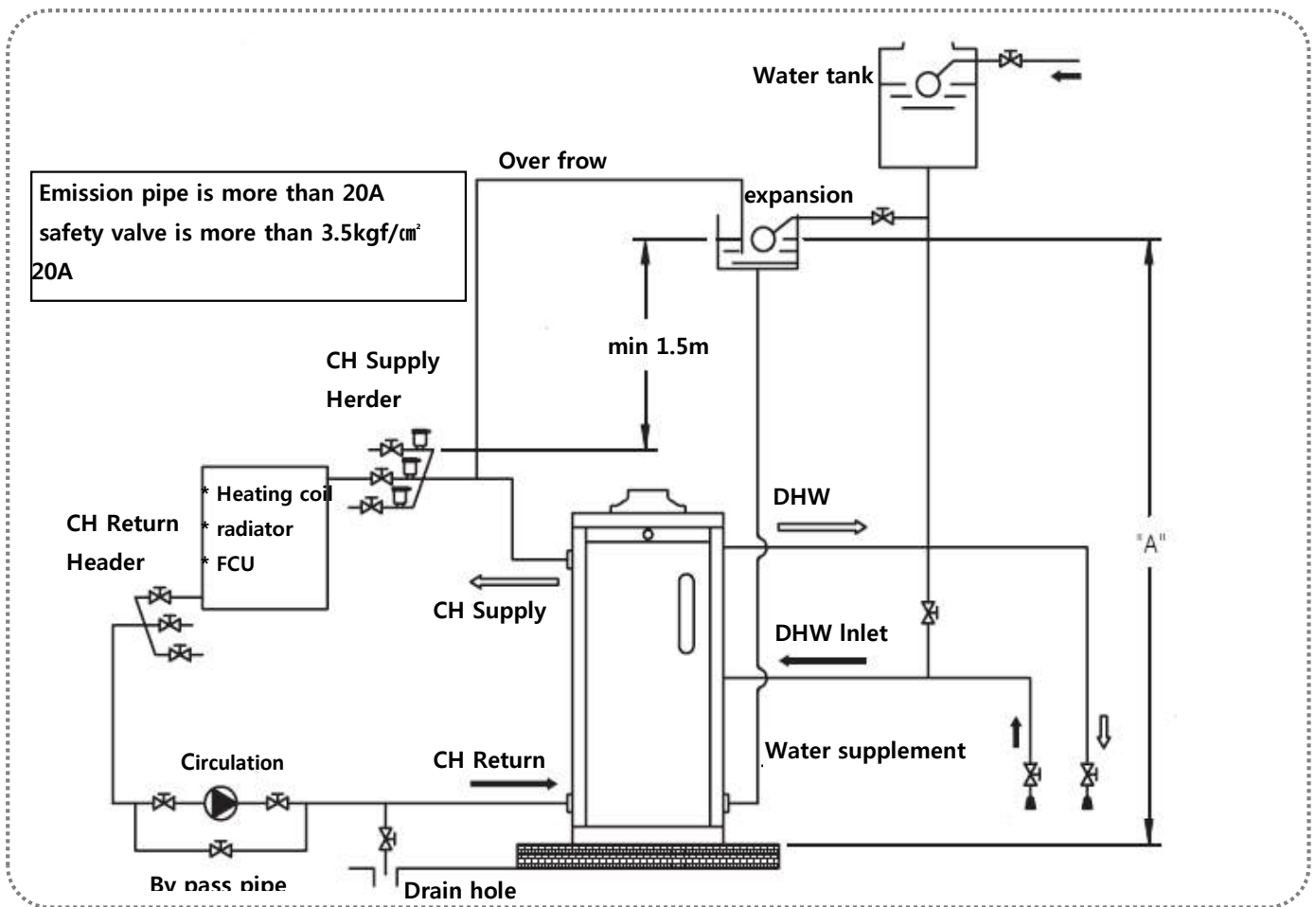

※ " A " height + pump pressure = less than the pump head pressure 35m

► Cautions in installing the pipe

1. Be sure to install a Air vent or Auto Air vent at the top of the pipes.
2. This product is for the working pressure $3.5\text{kgf}/\text{cm}^2$ of cold water supply. Therefore, Install the pipe in accordance with $3.5\text{kgf}/\text{cm}^2$
3. Don't install any valve such as a pressure reducing valve and a check valve at the water supplement and the drain pipe.

※ **Caution against the damage to the boiler due to user's negligence**

4. Please install an open type expansion tank or the nitrogen tank(closed type) and a safety valve, appropriate to the capacity of the boiler to prevent the damage by the thermal expansion pressure.
5. If the boiler is directly connected to the water supply pipe, it may be damaged due to the high pressure of water supply. Therefore, be sure to install a pressure reducing valve and a check valve.

※ **Keep the pressure of the cold water supply within $0.6 - 1.\text{kgf}/\text{cm}^2$ to use the hot water sufficiently.**

3-2-1 Installing Downward piping type

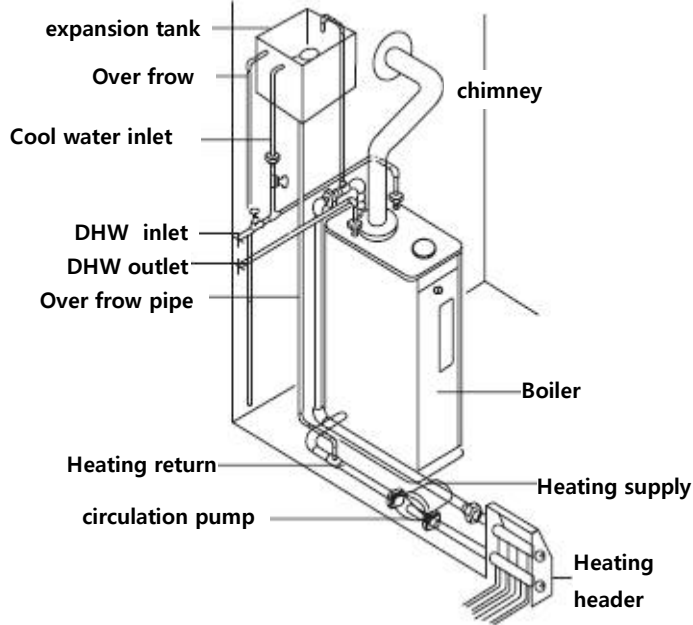

3-2-2 Installing Downward piping type (Diagram of Total Piping)

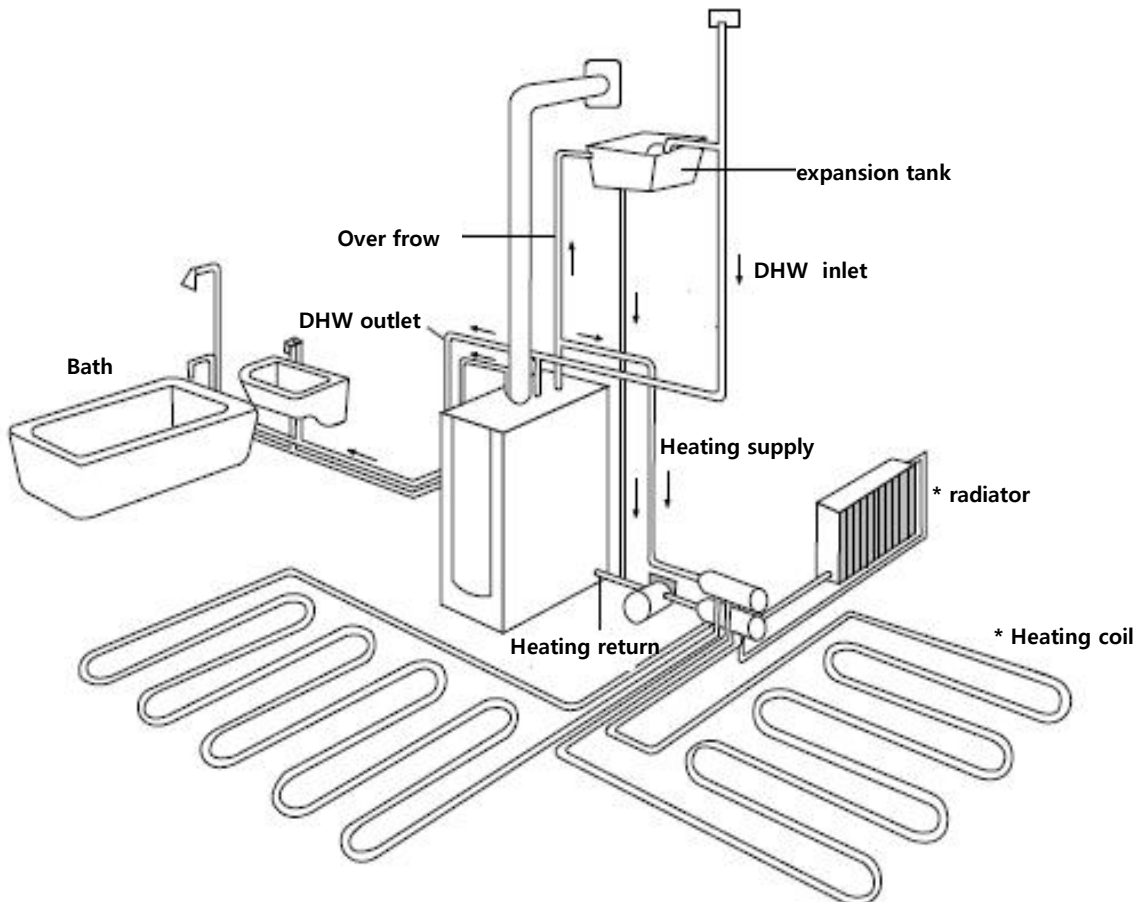

3-2-3 Installing Upward piping type

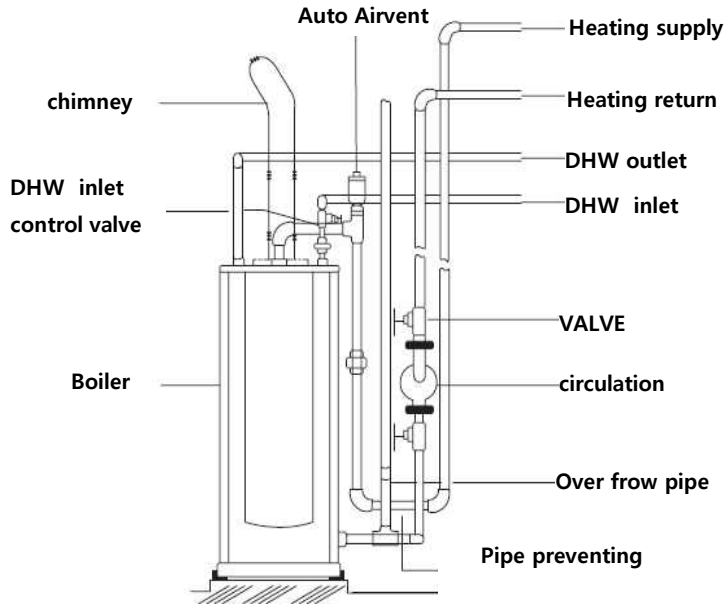

3-2-4 Installing Upward piping type (Diagram of Total Piping)

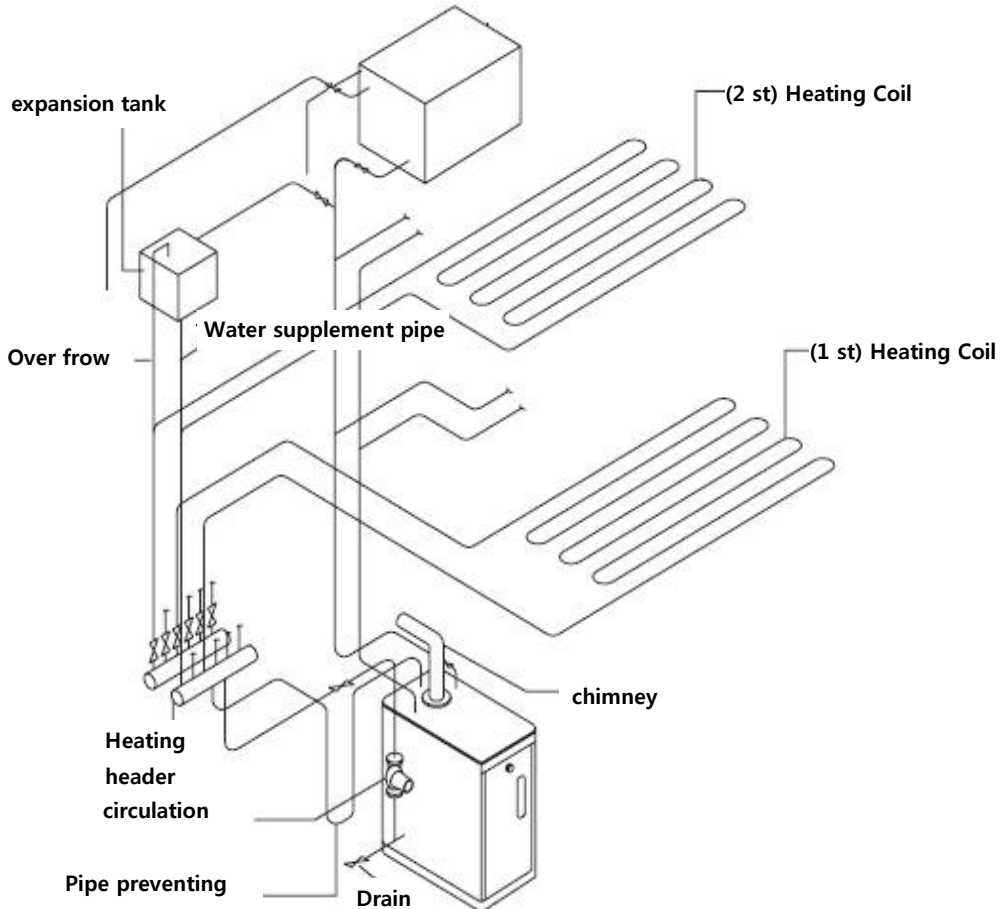

3 - 3 Standard oil pipe installation

Oil supply pipe

- When installing the Oil tank higher than Burner. (Upward type)

- ① KITURAMI burner is equipped the special filter, which protects gear pump and motor. When install the Oil tank higher than Burner, follow below instructions.
- ② The P should be lower than 4m to protect the Pump retainer.
- ③ Oil pressure from the pump should be less than 0.4bar/30cmHg.
- ④ As for Downward type Oil supply pipe, refer to below Figure and instructions.

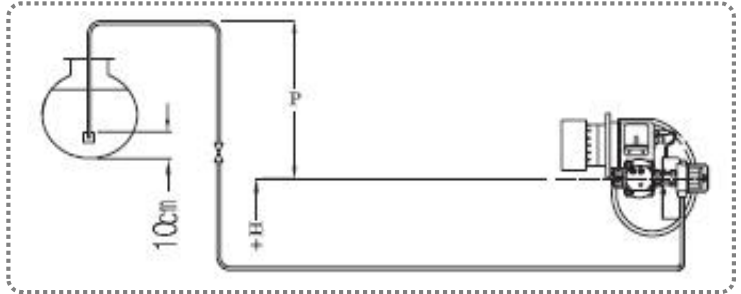

+H -H m	L (m)		
	6 (Ømm)	8 (Ømm)	10 (Ømm)
+4	21	67	100
+3	19	59	100
+2	16	51	100
+1	13	42	100
+0.5	12	38	94
0	11	34	84

H = Height from pump

L = Total length of Oil supply pipe

Values in the right table is for the Copper pipe of 8mm and 10mm, which can be substituted with the steel pipe of 1/4" , 3/8".

- When installing the Oil tank lower than Burner. (Downward type)

※ Caution : Surely check whether the return line is open or not. In case of operation of burner with it open, the retainer in pump will be damaged.

- ① Install the oil pipe, if possible, with the copper pipe, and check the air infiltration clearly.
- ② Place the both tips of return pipe and supply pipe at the same position.

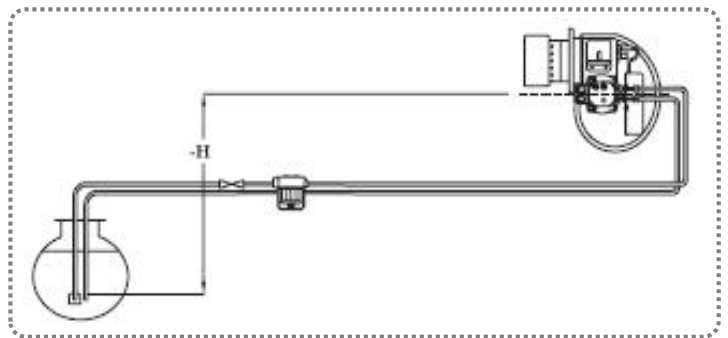

H = Height from pump

L = Total length of Oil supply pipe

Values in the right table is for the Copper pipe of 8mm and 10mm, which can be substituted with the steel pipe of 1/4" , 3/8".

+H -H m	L (m)		
	6 (Ømm)	8 (Ømm)	10 (Ømm)
0	11	34	84
-0.5	10	30	74
-1	8	26	64
-2	6	18	44
-3	3	10	24
-4	1	2	4

3 - 4 Oil Burner connection spec

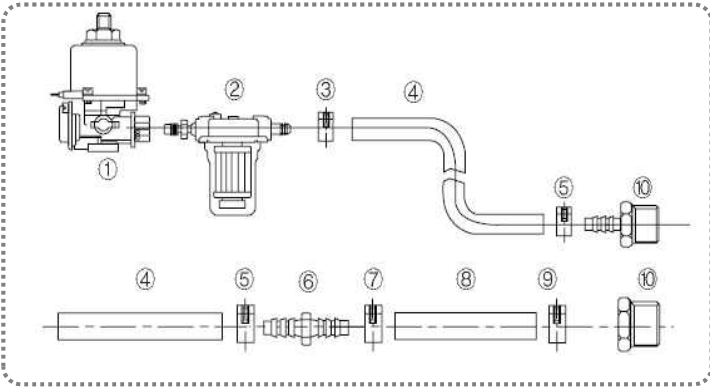

NO	Part name
①	Electronic Pump
②	Oil Filter
③ ⑤ ⑦ ⑨	Hose Band
④ ⑧	Rubber Oil Hose
⑩	Oil Tank connecting Nipple
⑥	Oil Hose extending Nipple

► How to connect the Oil pipe (only gear pump equipped boiler)

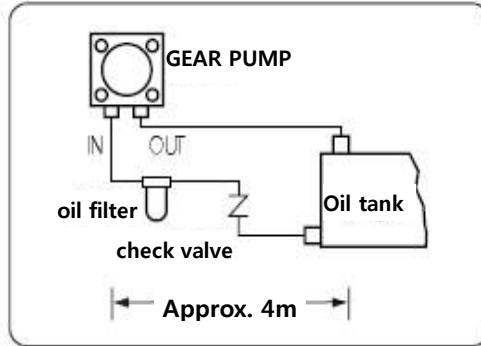
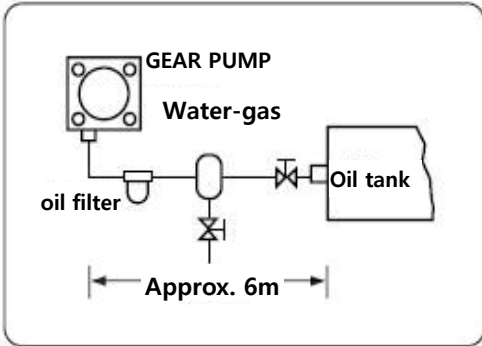

1) When the Oil tank is located higher than the Gear Pump : single piping, multy piping

2) When the Oil tank is located lower than the Gear Pump : multy piping

* Connect the Pipe from the lower part of oil tank, to gear pump's IN, and the Pipe from the upper part of oil tank to gear pump's OUT.

* If the height difference between the bottoms of oil tank and gear pump, is more than 3m, gear pump doesn't wo

※ Gear pump equipped boiler should use the diesel.

► How to connect the Oil pipe (only electronic pump equipped boiler)

1) If the Oil tank is located lower than the electronic pump, the boiler can't operate normally. Be sure to install the Oil tank higher.

2) Oil pipe should be installed as single piping.

※ Electronic pump equipped boiler can use diesel, oil and heating oil.

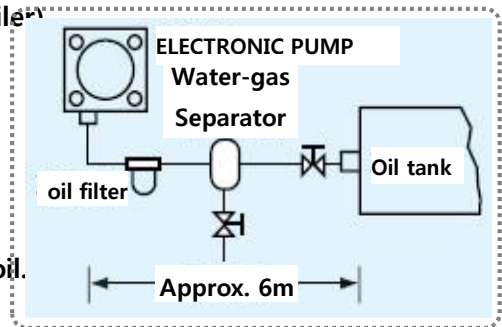

2. Water connection

1). The illustration shows the connections for the water and gas attachments of the boiler. See valves configuration

2). Check that the maximum water mains pressure does not exceed 3bar; if it does, a pressure reducing valve must be installed.

3). For measuring of the pipes and of the heating bodies in the heating system, the residual head value should be calculated as a function of the requested flow rate, in accordance with the valves shown in the circulation pump graph

3. Drain connection

1). Extend the hose from the safety valve and connect the drain hole.

※ Caution ; Do not store any wetttable things under the boiler or near the drain hole.

3 - 5 Connecting Electricity

3-5-1 Connecting Wires

※ This appliance is designed on **AC 220V ~ 230V/ 50Hz**.

This work of connecting wires is required by a qualified electrician.

1. Make sure that the earth connection is required for safety uses from any electric leakage or short-circuit.
2. Make sure that the connecting electricity - for example, connecting power and cable, wiring, earthing, etc - should comply with the regulation.
3. If this appliance is not earthed by power plug, ensure to earth separately, by minimum 30cm inserted in the ground. Note not to connect gas pipe, telephone wire and lightning conductor(rod) in order to avoid any accident from lightning, surge, or the gas accident.
4. Make sure that the socket outlet is apart by over 30 cm from the appliance.
5. The power outlet has to have at least the minimum clearance of 30mm from the gas boiler
6. The grounding point need to be buried at least 30cm

4. MAIN PART SPEC

4 - 1 GEAR PUMP

① Pressure of pump

- 10 bar : Adjusted pressure out of factory
- 12 bar : Change the pressure when the burner ignites at a low temperature.

② Structure of pump (based on DANFOSS pump)

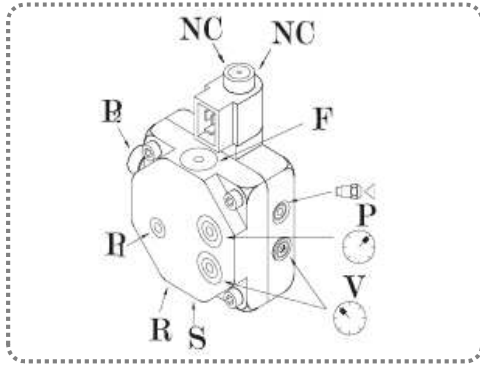

P ₁	Adjusting Pressure
P ₂	Cylinder Port
S	Inlet (Φ 1/4")
R	Outlet (Φ 1/4")
□	Nozzle Connection (Φ 1/8")
⊙	Pressure Gauge Connection (Φ 1/8")
⊙	Vacuum Gauge Connection (Φ 1/8")
F	Oil Filter Replacement

③ Gear pump work SYSTEM

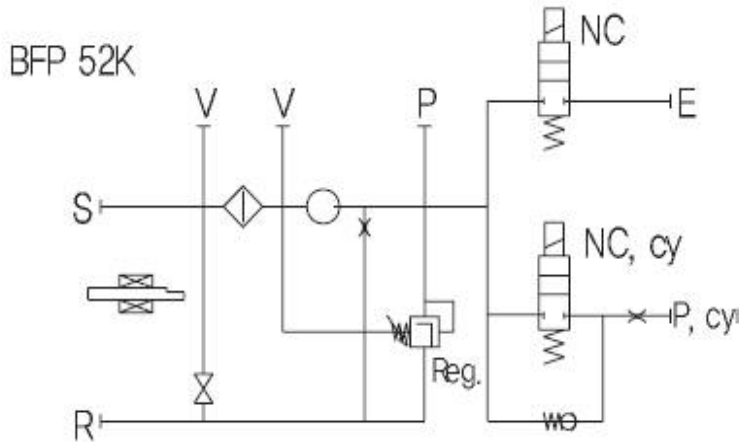

4 - 2 ELECTRONIC PUMP

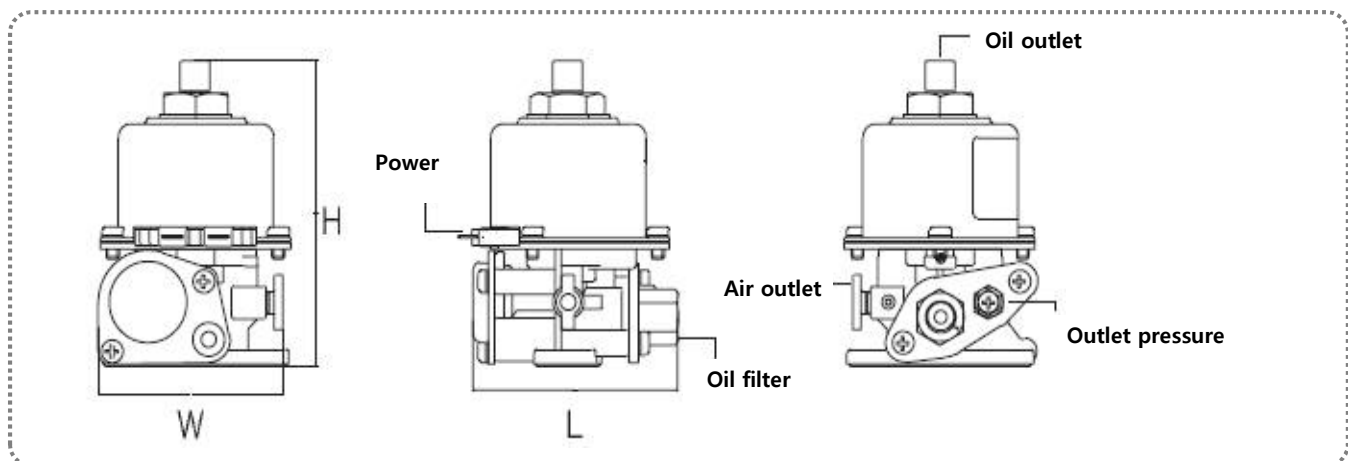

W x L x H = 60mm x 67mm x 89mm

④ How to adjust the Air damper (manual)

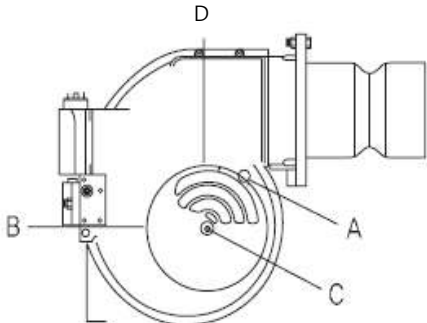

1. After loosening screw A, adjust B by hand.
2. After adjusting B to the desired number, fasten the screw A.
3. The number D is bigger, the air flow is more.

※ After checking the combustion status, adjust the air damper appropriately. In case of excessive or deficient air flow, imperfect combustion may occur.

⑤ How to adjust the Air damper (automatic)

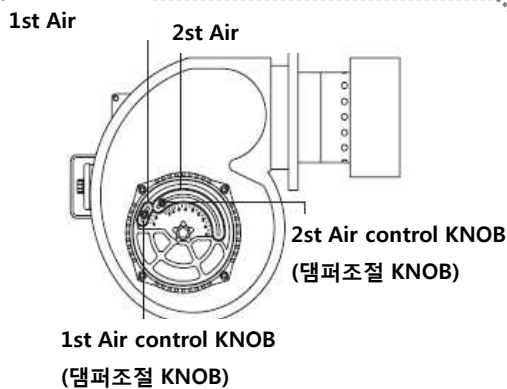

1. Loosen the 1st Air control KNOB by turning it counterclockwise.
2. Adjust the position of the Adjusting KNOB by rotating it counterclockwise (close) or clockwise (open).
3. After adjusting, fasten Adjusting KNOB by turning clockwise.

→ Adjusting method of 2nd Air control KNOB is identical to 1st Aircontrol KNOB.

→ Adjusted new location is applied after reactivation.

※ Air adjusting damper controls the 1st air inlet and the 2nd air inlet by the motor with the electronic control. It can inhale the exact amount of air to prevent a gas explosion at the initial ignition.

⑥ How to adjust the Air damper of Electronic Pump type Burner (Manual)

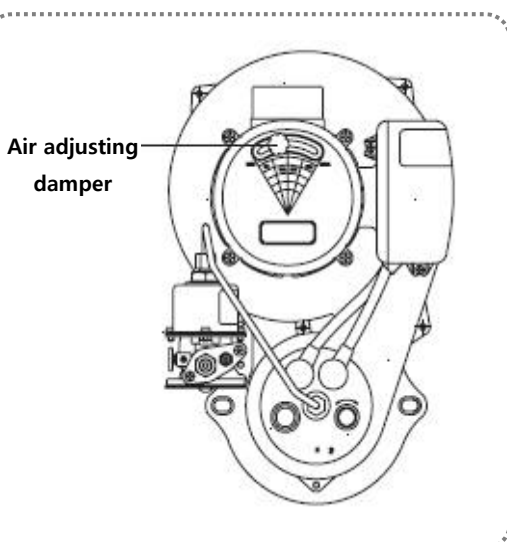

1. Loosen the Air control KNOB by turning it counterclockwise.
2. On Burner's operating, the more the knob is turned counterclockwise, the less the amount of air is.
3. On Burner's operating, the more the knob is turned clockwise, the more the amount of air is.
4. After adjusting for the perfect combustion, fasten Adjusting KNOB by turning clockwise.

4 - 3 IGNITION TRANSFORMER

① SPEC (KI-G50)

ITEM	VALUE	ITEM	VALUE
Power Supply	AC 220V ±15%(50Hz)	Power Consumption	20 W
Current	220 mA (Max)	Output Current	16.5kV (0 ~ +10%)
Consumption	33 mA (Min)	Output Frequency	15kHz (Min)
Allowable Temp.	(-10°C +70°C)	Fuse Rating	6A (instant)

② Name and Dimension

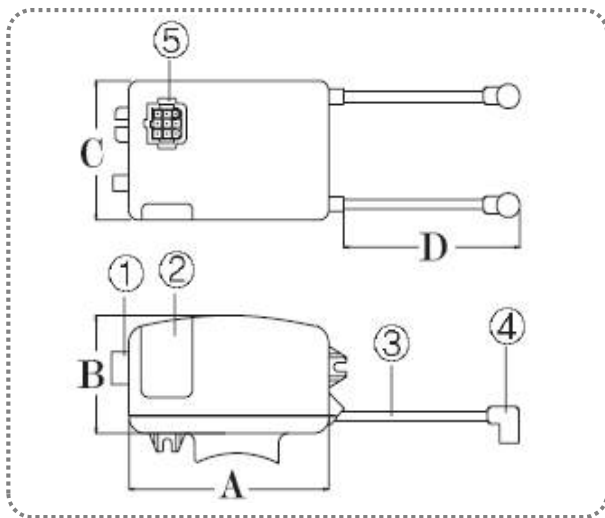

(mm)

A	105
B	60
C	70
D	170

1	Power connector
2	fuse Box
3	high tension WIRE
4	Ignition bar cap
5	9pin connector

4 - 4 CONNECTOR

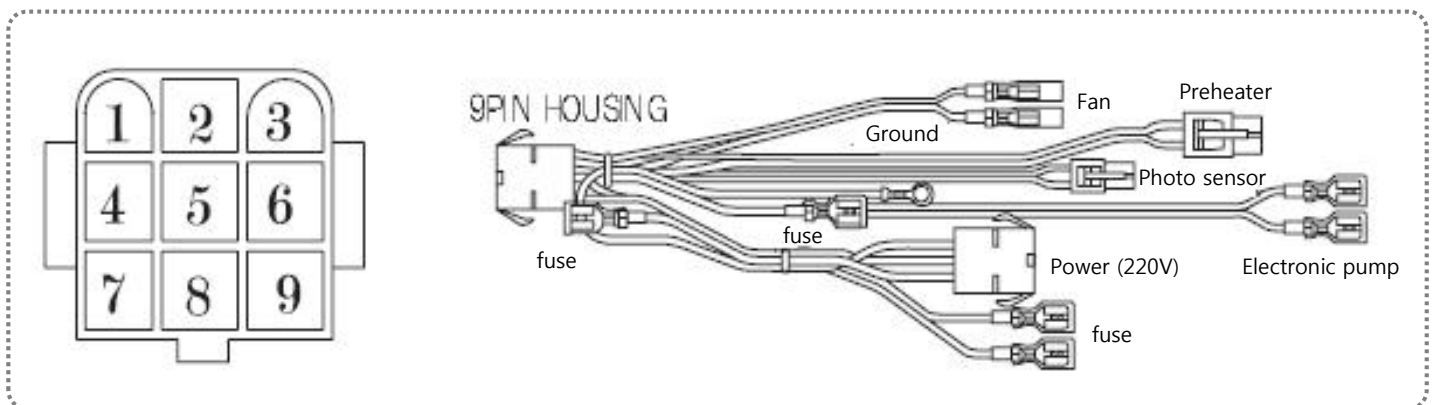

1	*	2	PHOTO SENSOR	3	PHOTO SENSOR
4	FAN	5	IGNITION TRANSFORMER	6	Electronic pump
7	FAN	8	Electronic pump	9	POWER

4 - 5 IGNITION BAR

► SPECIFICATION

ITEM	VALUE	ITEM	VALUE
Withstanding voltage	18 KV/mm	Hardness	97 M
Insulation Resistance	10 ¹⁴ - 10 ¹⁵ Ωcm	Thermal Resistance	190 °C
ARC Resistance	196 scc	Dielectric Constant	5.3

► Name and Dimension

DIMENSION (mm)			NAME	
A	TURBO-17	60	1	Ignition transformer Connection nipple
	TURBO-21	70		
B		26	2	Ignition rod Connection hole
C		3.5		
D		24	3	Electrode rod
E		11	4	Epoxy
F		14		

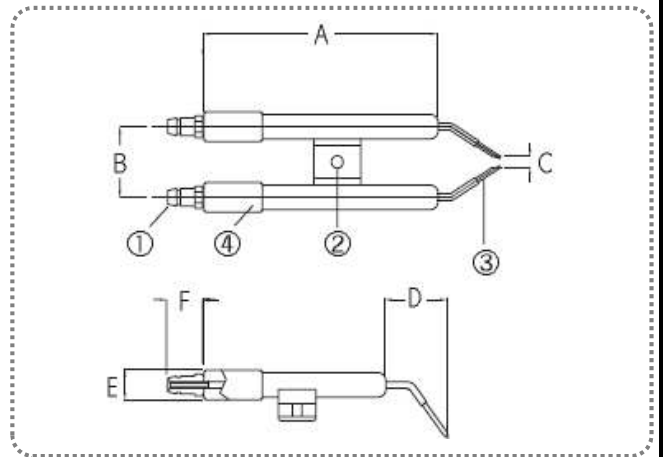

► How to adjust the location of ignition rod

1. Ignition rod carries 16.5k voltage. Before adjusting, plug off the power cord.
2. Don't adjust it at your discretion, it has been adjusted minutely out of factory.
3. If necessary, adjust the ignition rod as shown Figure.
4. Epoxy material protects electrode rod and prevent electrical short. Lots of soot may cause the intermittent ignition fault or ignition delay by electrical discharges. Therefore, check the soot and epoxy damage.

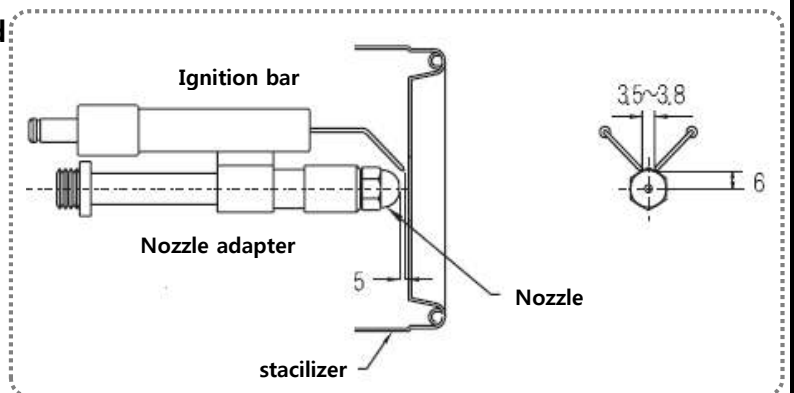

► TIME CHART

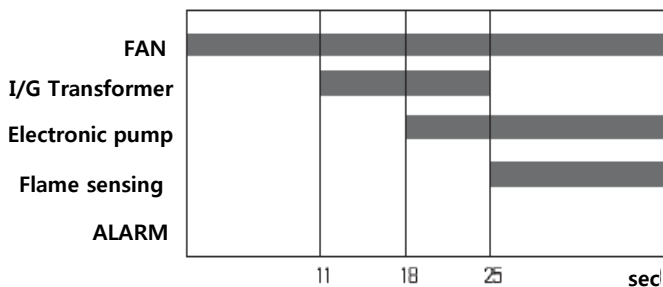

◆ Normal combustion

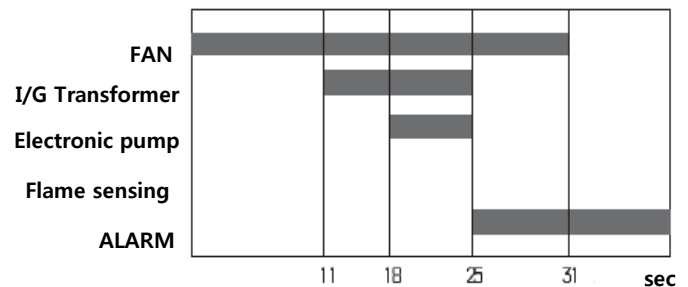

◆ Abnormal combustion

4 - 6 Adjustment and Oil Conversion

The following adjustment and conversion operations must be carried out by qualified personnel. KITURAMI Limited accepts no liability for damage to property or personal injury resulting from tampering with the boiler by unauthorized persons.

1. Burner specification by Capacity

MODEL	UNIT	TURBO-17	TURBO-21	TURBO-25	TURBO-30
CAPACITY	kW	81.4	116.3	174.4	232.6
	kcal/h	70,000	100,000	150,000	200,000
Fuel Consumption	Lit/h	9.5	13.9	20.5	27.2
Nozzle specification	G/H	2.0x60°H/45°B	3.5x60°H/45°B	16.5x60°H/45°B	16.5x60°H/45°B
	Q' TY	1EA	1EA	1EA	1EA
Burner controller		CTX-7000MV	CTX-7000MV	CTX-7000MV	CTX-7000MV
Flame detect		Photo tube type	Photo tube type	Photo tube type	Photo tube type
GEAR TYPE		58 kg/h	58 kg/h	58 kg/h	58 kg/h
		7 ~ 15	7 ~ 15	7 ~ 15	7 ~ 15
		10 kg/cm ²	10 kg/cm ²	10 kg/cm ²	10 kg/cm ²
		— 10 ~ 70	— 10 ~ 70	— 10 ~ 70	— 10 ~ 70
ELECTRONIC TYPE		7 kg/h	7 kg/h		
		7 ~ 12	7 ~ 12		
		10 kg/cm ²	10 kg/cm ²		
		— 5 ~ 60	— 5 ~ 60		

5. Burner Direction for assembly

5 - 1 Burner Part exploded view

1). CAPACITY : TURBO - 17K , 21K

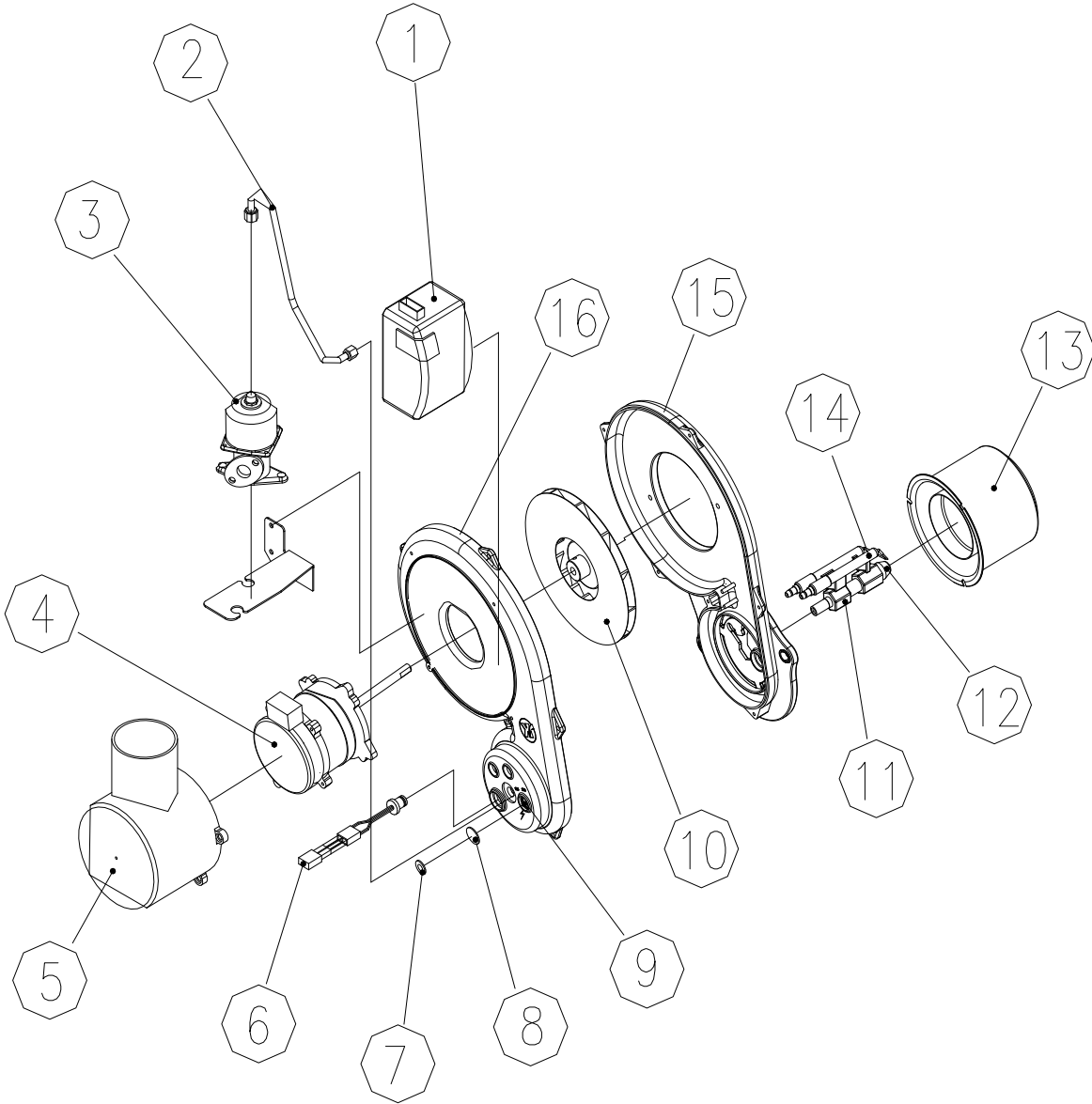

NO	NAME	NO	NAME	NO	NAME
1	IGNITION TRANSFORMER	2	OIL SUPPLY PIPE	3	ELECTRONIC PUMP
4	MORTOR (BURNER)	5	MOTOR COVER	6	PHOTO SENSOR
7	C-RING	8	MICA	9	PEEP HOLE
10	FAN	11	NOZZLE HOLDER	12	Nozzle
13	STEBILRAIGE	14	IGNITION BAR	15	BURNER BODY (FRONT)
16	BURNER BODY (REAR)				

1). CAPACITY : TURBO - 25K , 30K

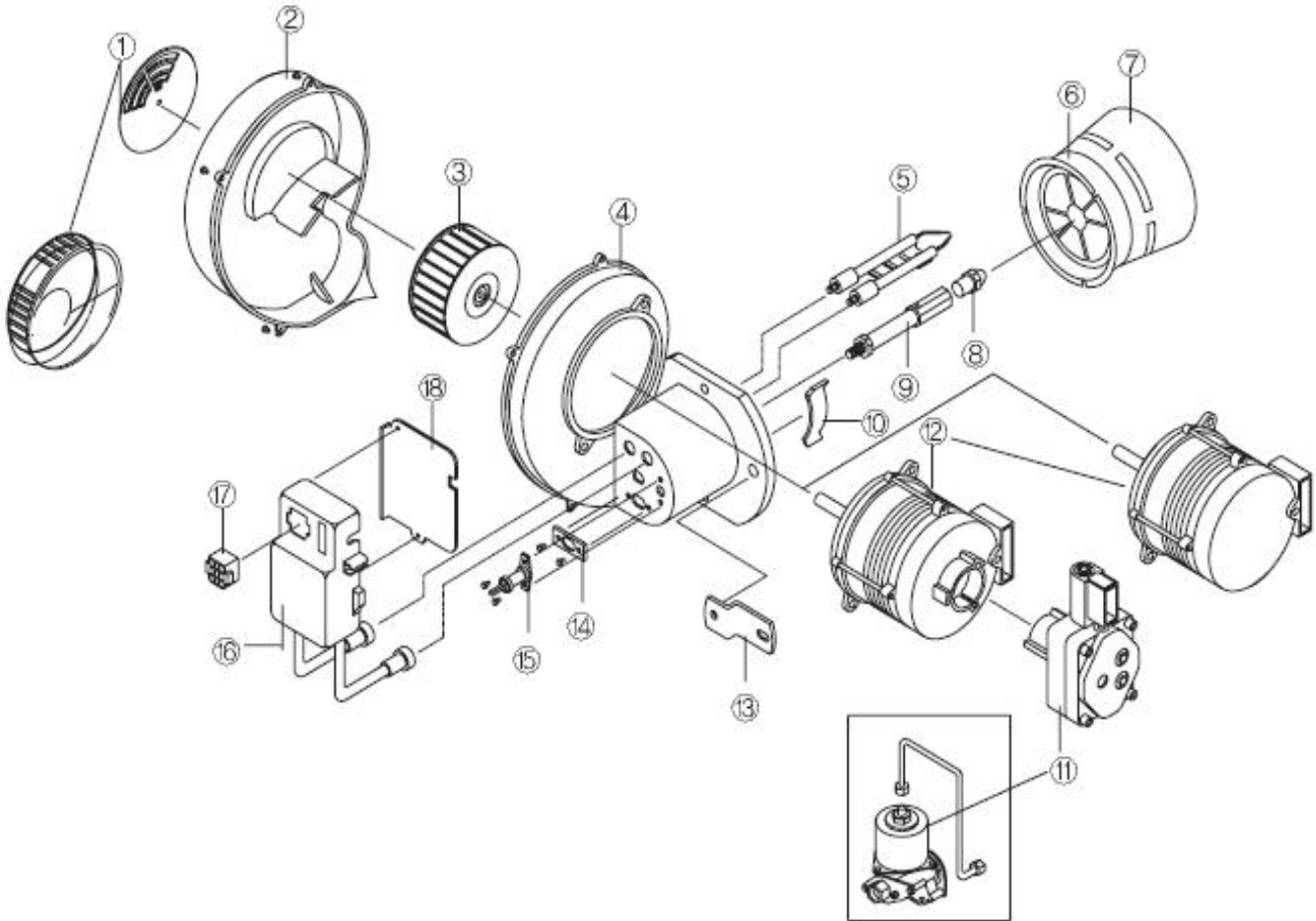

NO	NAME	NO	NAME	NO	NAME
1	DAMPER (AUTO/MANUAL)	2	FAN CASE	3	FAN
4	BODY	5	IGNITION BAR	6	STABILIZER
7	BURNER TUBE	8	NOZZLE	9	NOZZLE ADAPTOR
10	GUIDE	11	GEAR , ELECTRONIC PUMP	12	MOTOR
13	BRACKET (FLANGE)	14	BRACKET (PHOTO SENSOR)	15	PHOTO SENSOR
16	IGNITION TRANSFORMER	17	9PIN CONNECTOR	18	BRACKET (TRANSFORMER)

6. TEST WORKING

6 - 1 Check list before switching-on

1). Before switching-on, please check the followings after finishing the installation of boiler, flue, pipes, and electricity.

- ① Is the boiler connected to the boiler-dedicated electrical outlet?
- ② Are there some combustibile materials around the flue?
- ③ Has the boiler been installed in boiler-dedicated and well ventilated room?
- ④ Is there enough space for boiler inspection?
- ⑤ Does the boiler have good drainage on operating?
- ⑥ Has the boiler been installed horizontally on the nonflammable floor such as concrete floor or bricks?
- ⑦ Has the boiler's flue been kept warm completely?
- ⑧ Has the thermostat been connected to lines accurately?

①



②



③



④

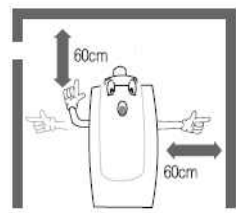

⑤



⑥

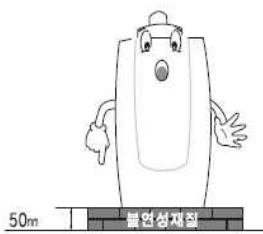

⑦



⑧

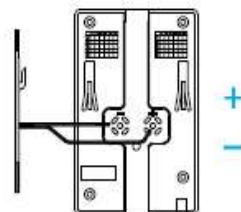

7. Direction for assembly

7 - 1 Boiler Part exploded view

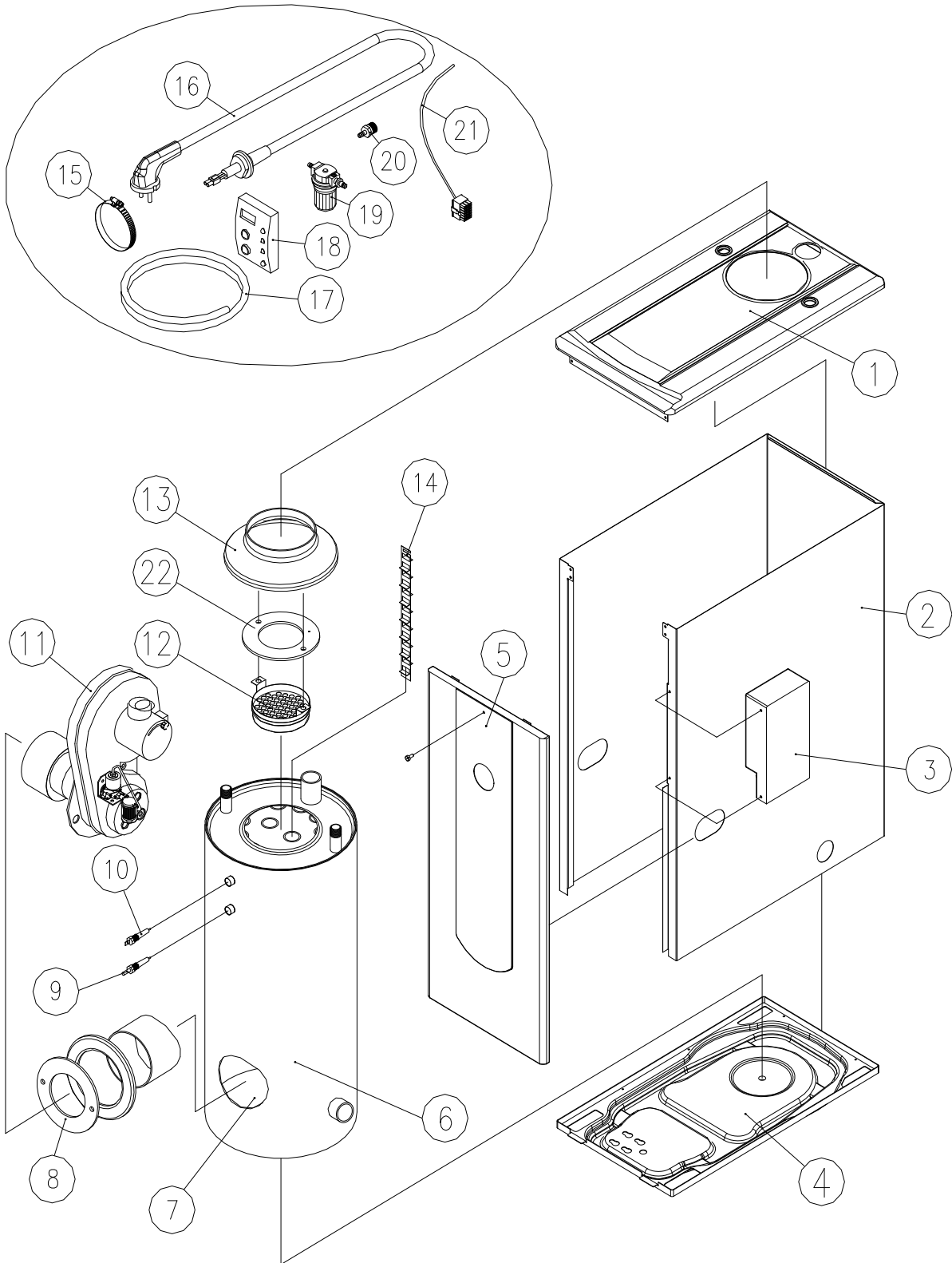

7 - 2 Part name

No	Part Name (English)	Korean	ERP Code	Model			
				17K	21K	25K	30K
1	Top cover	상부 커버					
2	Case (side)	케이스 (옆면)					
3	Main controller	메인 콘트롤러					
4	Bottom cover	하부 커버					
5	Front door	전면 도어					
6	Heat exchanger	열교환기					
7	cestabul	케스타블					
8	Gasket (burner)	가스켓 (버너)					
9	Temperature sensor	온도 센서					
10	Low water sensor	저수위 센서					
11	Burner (ASS'Y)	버너					
12	Silencer	소음기					
13	Damper ring	담바링					
14	Buffle plate	버플 플레이트					
15	Stainess band	스텐밴드					
16	Power code	파워 코드					
17	Oil hose	오일호스					
18	Room control	룸콘트롤러					
19	Oil filter	오일 필터					
20	Connector	콘넥타					
21	Bushing (Oil hose)	붓싱 (오일호스)					
22	Gasket (Hood)	가스켓 (후드)					

8. MAINTENCE GUIDE

8 - 1. Assembly Instructions for Burner

Tool

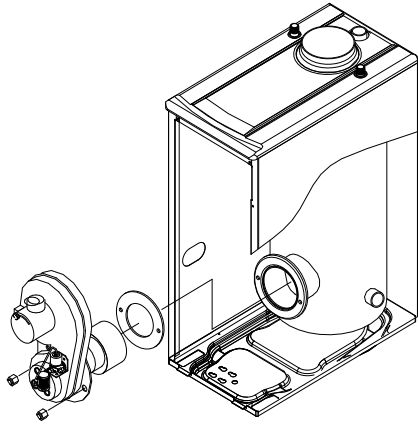

1. Plug off the power cord.
2. Close the Oil valve connected with the oil tank.
3. Disassemble screws fixed on front panel and open the panel.

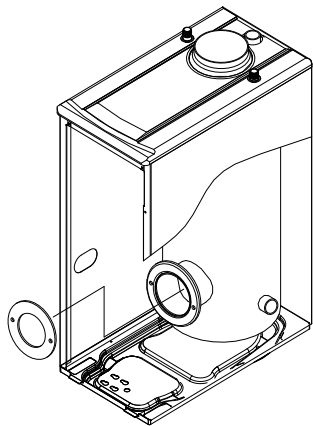

1. Separate the connector plug from burner.
2. Remove two nuts on burner flange by spanner.
3. Separate the burner by pulling forward.

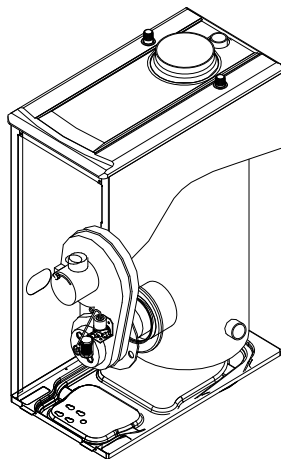

1. Replace the gasket fixed on flange with new one.
2. Check the status of Burner (interval and fixed state of ignition rod) and assemble the burner on flange.
3. Fix the burner by tightening nuts.
4. Assemble the connector plug on the exact location.

8 - 2. Assembly Instructions for the Temperature and Overheating Sensors

Tool



2

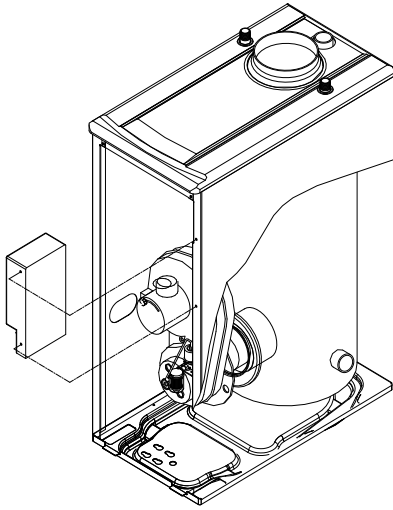

1. Plug off the power cord.
2. Close the oil valve connected with the oil tank.
3. Close the valves connected with the heating and hot water pipes.
4. Loosen screws fixed on front panel and open the panel.
5. Separate the control box and connector plug fixed on the front of Heat exchanger.

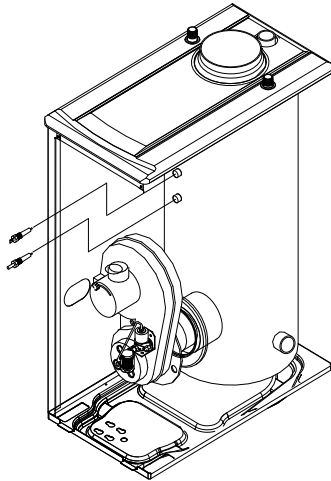

1. Separate Temperature Sensor or Overheating Sensor by turning it counterclockwise with a spanner.

※ **Check the scale on the Sensors.**

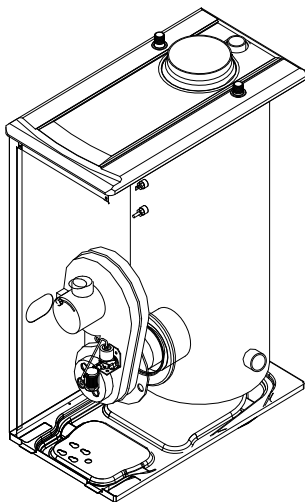

1. After sealing the Sensor by Teflon, Assemble the Sensor at the exact location by turning clockwise.
 2. Connect the Sensor with connector plug.
- ※ **After opening pipe valve, check the water leakage.**
3. Assemble the connector plug and control box.

8 - 3. How to clean Heat exchanger's Exhaust tube

Tool

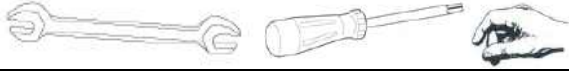

3

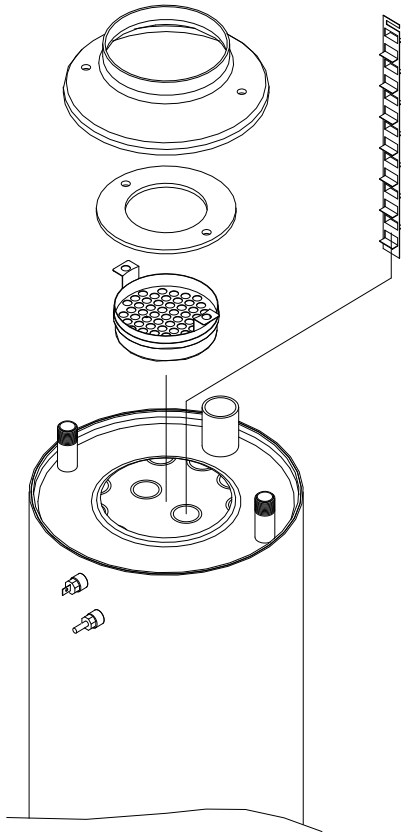

1. Plug off the power cord.
2. Close the oil valve connected with the oil tank.
3. Loosen screws fixed on front panel and open the panel.
4. Loosen screws fixed on the top of Heat exchanger and separate the panel.
5. Untie stainless band on the flue and separate the flue.
6. Loosen nuts fixed on Damper ring and separate Damper ring from Exhaust hood.
7. Check the soot status of top of the Heat exchanger and take Baffle plates out of Exhaust tubes.
8. Clean the soot inside the Exhaust tubes by using brush or chemical.
9. In reverse order, assemble Heat exchanger.

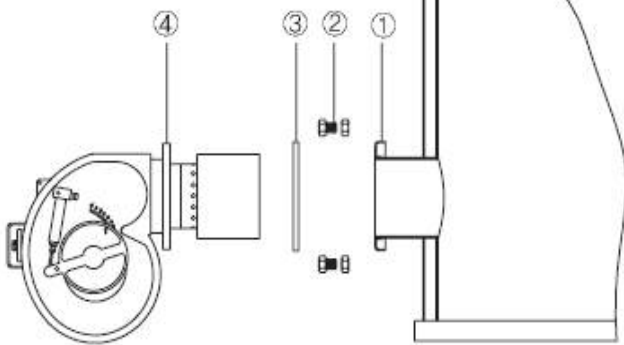

- ① Flange of Boiler
- ② Fixing Bolt
- ③ Sealing Gasket
- ④ Flange of Burner

9. Functions of the controller

9 - 1 Main Controller part name

Model : CTX - 1500

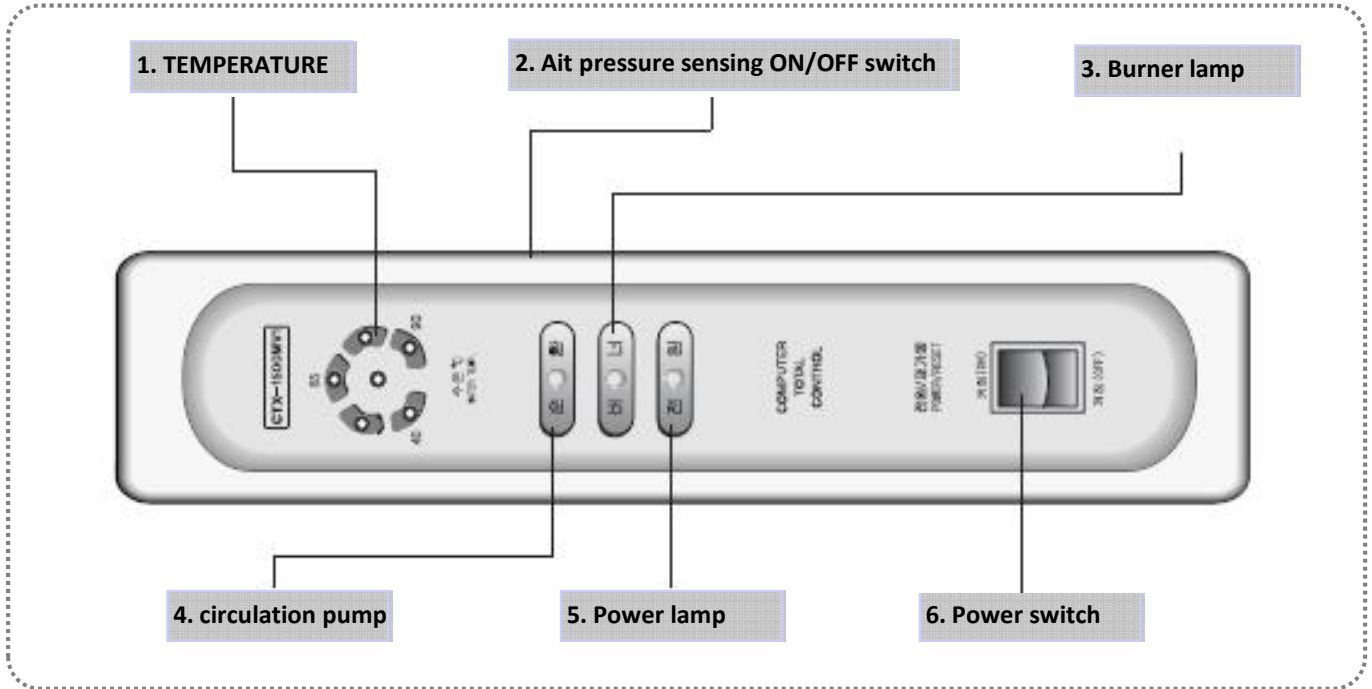

► Parts Description

1. TEMPERATURE

Displays current water temperature in the Heat exchanger of boiler.
(Flickers in case of the lack of water in Heat exchanger.)

2. Ait pressure sensing ON/OFF switch

Lights when Burner operates.

3. Burner lamp

4. circulation pump

Lights when Circulation Pump operates.
(Flickers when the water in Heat exchanger overheats.)

5. Power lamp

Lights when Power is ON.
(Flickers when detecting abnormal signal between Room controller and Main controller.)

6. Power switch

Switch for boiler power On/Off or Restart

9 - 2 Room Control panel (CTR-5700 plus)

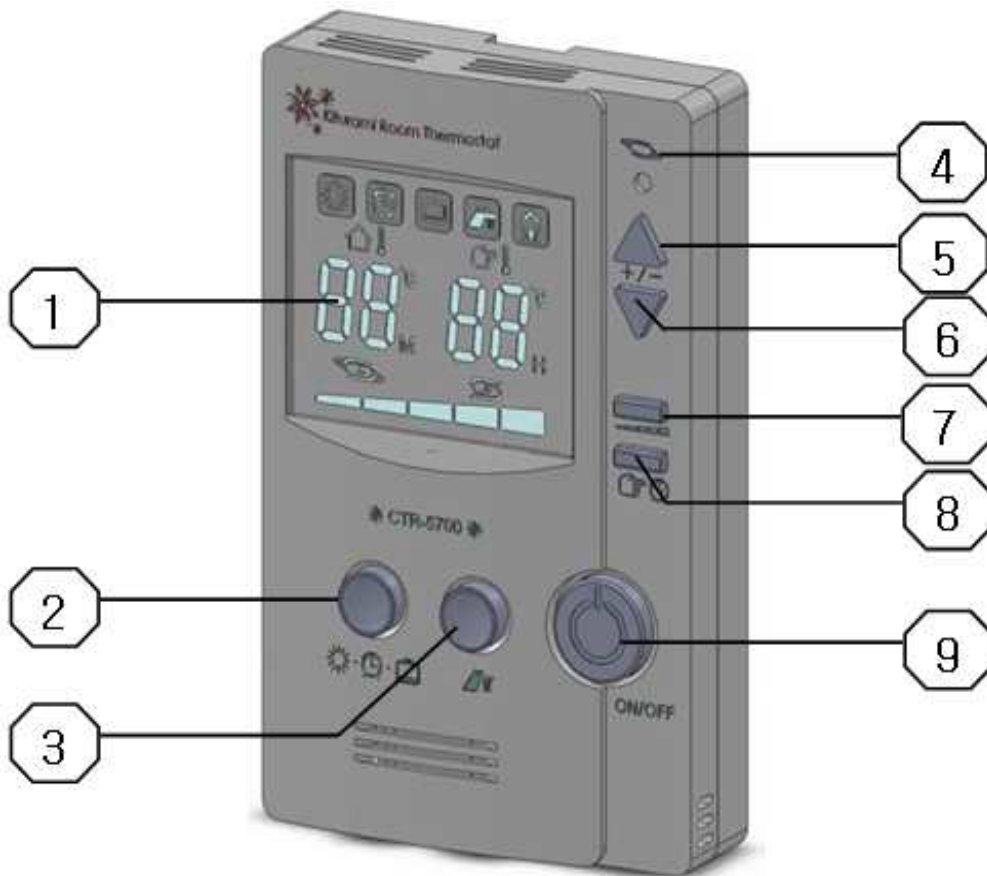

◎ LEGEND

1. LED panel
2. BOILER HEATING OPERATING CONDITION SELECT BUTTON
(RPPM TEMPERATURE HEATING, TIMER HEATING, OUT GOING)
3. DOMESTIC HOT WATER, ONLY
4. GREEN INDICATOR - POWER SUPPLY
5. ADJUSTMENT NUMERIC INCREASING BUTTON EACH EUNCTION
6. ADJUSTMENT NUMERIC DECREASING BUTTON WITH EACH FUNCTION
7. CH TEMPERAYURE ADJUSTMENT BUTTON.
8. TIMER ADJUSTEMENT BUTTON

9 - 3 Room control LED panel

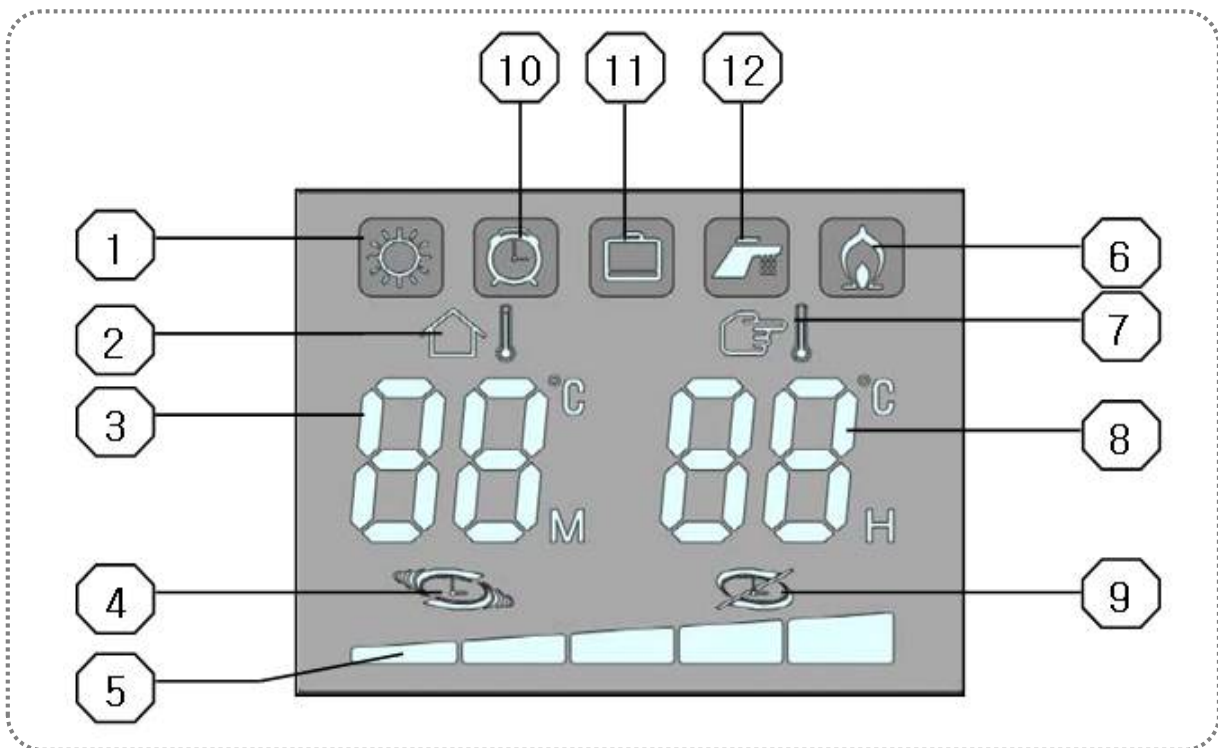

◎ Display Features

1. When the boiler operates with room temperature heating mode, this symbol display
2. When the boiler operates with room temperature heating mode, this symbol display.
3. Current's room temperature display in accordance with each heating modes
4. When the boiler operates with timer mode, this symbol display.
5. When the boiler operates with heating temperature mode, adjusted heating temperature display. More the BAR's numbers, the heating temperature is higher
6. When the boiler is operating in each setting mode, this symbol display
7. When set the room temperature will changing, this symbol display.
8. When the room temperature will be changing, this symbol display
9. When the boiler doesn't operate with timer mode, this symbol display
10. When the boiler operates with timer heating mode, this symbol display
11. When the boiler operates with outgoing mode, this symbol display.
12. When the boiler operates with DHW mode, this symbol display

10. Troubleshooting guide (error code)

10 - 1 Finding fault

Error code

The error codes display when errors occur

The last ten errors are saved in the appliance error memory

→ Press the "Timer" button for 5 seconds

→ Automatically the last errors history display 2 times by step on LCD panel.

You can exit the error memory display as follow;

→ Do not press any button return to the former times display

Code	Meaning	Cause
E 01	When failed to ignite initially and to do so by it's third try	It is due to the fuel shortage or interruption to the fuel supply caused by air inflow into gear pump. So refuel or emit the air to outside after checking the fuel volume.
E 02	When photo sensor failed to detect flame at the moment of ignition.	It is occurred when photo sensor is broken down or it can't detect light as the foreign substances are caught between the sensor part. Remove the foreign substances from the sensor part or replace it.
E 03	When flame was detected in the combustion chamber at the moment of initial ignition.	Check that there remains residual flame in the combustion chamber before initial ignition. and use a boiler after closing the front door tight. Even sunlight or fluorescent light can be detected and it may cause an error.
E 04	Interruption in heating temperature sensor	Sensor connection defective, sensor faulty
E 08	No communication with the PCB	Communication faulty between the room controller and the PCB. PCB faulty, Room controller faulty
E 95	Not enough water in the heating system	Filling the water into the heating system
E 96	High temperature limiter actuated	Flow probe not connected thermally correct or defective, appliance does not shut down
When there is absolutely no power supply in spite of turning on the controller and room thermostat controller.		* After checking a power cord putting in, pull out the power cord. And identify that whether power is in by putting in another home appliances power cord. * If power is in but boiler doesn't operate, check the disconnection state of the fuse inserted in burner ignition trans. And change it in order to operate the boiler.
When room thermostat controller displays normal operations although it is not working..		* Check circulation pump in the boiler is operating. ※ There is a possibility that circulation pump doesn't rotate itself due to fixation. In this case having a initial forced rotation by using a screwdriver.

11. Technical Data Table

Technical Specification		Model	TURBO - 17	TURBO - 21	TURBO - 25	TURBO - 30
Heating Output (Max-Min) (Flow/Return 80/60°C)		kW (kcal/h)	19.7 (17,000)	24.4 (21,000)	29.1 (25,000)	34.9 (30,000)
Heating Input (Max-Min)		Nm ³ /h	2.15	2.8		4.3
Heating area(Max)		m ²	93	115	137	165
Combustion scope	MIN	kW (kca/h/kg/h)	12 (10,300 / 1.0)	19 (16,480 / 1.6)	26 (22,360 / 2.2)	33 (28,380 / 2.8)
	MAX	kW (kca/h/kg/h)	22.7 (19,550 / 1.9)	28 (24,150 / 2.3)	34 (29,240 / 2.8)	40 (34,400 / 3.3)
Useful Efficiency at Max-Min Heating Output (Flow/Return 80/60°C)		%	92.8	93.2	93.4	93
Energy Performance		star	★★	★★	★★	★★
Motor spec		rpm	2850	2850	2850	2850
		W	157	157/155	157/155	155
		A	0.73	0.73 / 0.7	0.73 / 0.7	0.7
Motor condenser			1.2 / 440	1.2 / 440	6 / 450	6 / 450
Ignition transformer		V1-V2 I1-I2	220V / 16.5KV 0.2 A under 32 mA above			
Electric pump		kg/h	3.5	3.5	3.5	3.5
		Regulation scope	7 ~ 12	7 ~ 12	7 ~ 12	7 ~ 12
		Use pressure (kg/cm ²)	10	10	10	10
		Use temperature (°C)	60	60	60	60
Ki a pump		kg/h	-	58	58	58
		Regulation scope	-	7 ~ 15	7 ~ 15	7 ~ 15
		Use pressure (kg/cm ²)	-	10	10	10
		Use temperature (°C)	-	-10 ~ 70	-10 ~ 70	-10 ~ 70
Burner Consuming war potential		W	75/80	160	160/145	165/145
flame detecting type			infrared rays sensor type			
Purpose			Heating and Domestic Hot Water Production			
Heating Water Circulation Method			Air Closed & Open Type			
Max Heating Water Pressure		bar (psi)	3.0 (43.5)			
Max Heating Temperature		°C (°F)	85 (185)			
Adjustable Temperature Heating		°C (°F)	45 - 80 (113 ~ 176)			
Domestic Hot Water Output		kW (kcal/h)	19.7 (17,000)	24.4 (21,000)	29.1 (25,000)	34.9 (30,000)
Min working Pressure for DHW		bar (psi)	0.2 (2.9)			
Min working Flow Rate for DHW		ℓ / min (gpm)	1.60 (0.42)			
Max Domestic Hot Water Pressure		bar (psi)	17.5 (253.8)			
Other Domestic Hot Water Rate		△t=25°C ℓ / min	11.3	14	16.6	20
		△t=30°C ℓ / min	9.4	11.7	13.9	16.7
		△t=40°C ℓ / min	7.1	8.7	10.4	12.5
Electrical Supply		V/Hz	230V / 50Hz			
Power consumption		W	102	170	186	195
Installation Type			Standing Type			
Intake/Exhaust Flue System Type		Φ	(80) FE	(80) FE	(80) FE	(80) FE
Heating water Connection		(A)	32	32	32	32
Domestic Hot Water Connection		(A)	15	15	15	15
Physical dimensions		W x D x H mm	325 x 602 x 815		360 x 650 x 915	360 x 650 x 915
Weight		kg	57	58		85
Oil Type			Light Oil			
Control method			1 stage	1 stage	1 stage	1 stage
nozzle			0.5G x 60 ° H	0.6G x 60 ° H	0.75G x 60 ° H	0.85G x 60 ° H

* Specifications are subject to change without prior notice to improve design and performance

13. Warranty

Model name		Manufacturing number	
Period of guarantee	2 years		Agent signature
Date of sale	※		※You have to have a record here to receive service free of charge.
Customer	Address		
	Tel. No		
	Name		

Terms and Conditions

- ◎ This product is insured for an amount of up to 200 million won. If a consumer or a 3rd party suffers physical or material damage due to product default, compensation is paid in an amount of up to two hundred million won.
- ◎ Free repair service is available for two years after installation given normal exploitation of product.
- ※ Free service is available only during guaranteed period. Repair will be charged if damage was caused by user's negligence or in the following cases.
 - Service was not received in any of Kiturami's service centers or damage is done as a result of discretionary interference by the user or installer.
 - Damage is caused by a natural disaster, fire, flooding, moisture, or negligent maintenance.
 - Boiler is damaged because of water condensation due to straight chimney.
 - Damage is caused by continuous use of boiler disregarding collection of waste gas inside the product due to bad funnelling.
 - Damage is caused by excessive water extension pressure due to improper installation of pipes, valves or other parts.
 - Customer does not have the guarantee of quality or the guarantee is not filled in required areas.
 - Damage is caused by use of water with salts or limestone or subterranean water.
 - Damage is caused by user's carelessness as a result of winter snowing.

Warranty cannot be reissued so keep it safety.