



2013 Owners Handbook

Coachman 5 Year Warranty



the journey starts here...

CONTENTS

All Coachman Caravan models have been certified by the National Caravan Council for compliance with stringent European Standards, British Legislation and Industry set Codes of Practice specifically relating to health and safety issues. The approval process covers the testing and inspection of critical areas of the product from fire safety, weights and dimensions to gas, electrics and ventilation. Every Coachman Caravan carries the “NCC Approved Caravan” badge. The NCC also conducts unannounced inspections at the Coachman factory to ensure continued compliance. **NCC approval gives you peace of mind that your caravan is legal and safe.**

Not all equipment described is fitted to every derivative, to check your individual specification please check with the brochures and your Dealer.

All the illustrations and descriptive matter in this guide are intended to give a general idea of the caravan. Changing market and supply situations may prevent us from maintaining exact specification details in this guide and we therefore reserve the right to alter specifications as materials and conditions demand.

Please check current details with your dealer and inspect the caravan to ensure it is satisfactory before purchase. Dealers are not agents and have absolutely no authority to bind Coachman Caravan Company Limited by any express or implied undertaking or representation.

Introduction	2	Caravan Equipment`	46
Security	5	Combi Heater	46
Your Caravan	6	Control Panel	49
Towing Code	8	Aldi Heating/Water System	52
Preparing for the Road	11	Refrigerator	53
Pre-Tow Checklist	13	Oven, Hob & Grill	60
Coupling Up Checklist	21	Microwave	66
Towing & Driving	22	Smoke Alarm & CO2 Alarm	67
Reversing	22	Thetford Cassette Toilet	73
Pulling Off	22	Rooflights	76
Caravan Handling	22	Omnivent	77
Changing a Wheel	23	Mini Heki	79
Safety & Security	24	Midi Heki	81
Fitment of AL-KO Secure	25	Entertainment System	82
Arrival at Site	27	Television & Radio Aerial	83
Connecting Services	28	Security Alarm System	86
Water	28	Beds & Bunks	88
Gas	34	Care of your Caravan	89
Electricity	38	Cleaning	89
		Storage	93
		Maintenance	94
		AL-KO Chassis	94
		Servicing	98
		Warranty	101

**Coachman Caravan Company Limited, Amsterdam Road,
Sutton Fields Industrial Estate, Hull, HU7 0XF Tel: (01482) 877405**

INTRODUCTION

WELCOME TO THE WORLD OF CARAVANS

You are now the owner of a quality caravan. The User's Guide has been prepared for your guidance to help you derive the greatest amount of pleasure from the use of your caravan. It is recommended that you read the pages of this guide thoroughly so that you are fully conversant with all the caravan systems. The major proprietary components of the caravan such as the chassis, space heater, oven, water heater, refrigerator and electrical control systems all have their own comprehensive operating instructions which should be supplied with your caravan. It is strongly recommended that you read these too as it is not possible to include all the information they contain in this handbook.

Your supplying distributor is responsible for carrying out a thorough pre-delivery inspection on your caravan and also for arranging any warranty work or routine servicing which may be required.

Authorised Dealers will be able to supply any replacement parts for your caravan, should the need arise, along with any accessories you may require. Please note that it is not possible to purchase replacement parts or accessories direct from the manufacturer.

We are sure you will have many happy times with your caravan but please remember a happy carefree time is based on proper, thorough and responsible preparation, careful driving with regard to the "Rules of the Road", other road users and above all ensuring your caravan is in a first class roadworthy condition. It is a condition of your warranty that your caravan is serviced by an authorised Dealer once every twelve months and that the service record in the back of your Warranty and Service Manual, is maintained in accordance with instructions.

Your Coachman Caravan has been designed as a luxury recreational vehicle and is **intended for recreational use only**. It is not intended for living in, using for business purposes, or hiring, and the Company accepts no liability if the caravan is used for any purposes other than holidays.

To ensure the very best quality and reliability the caravan has been through an extensive design and testing programme. Therefore **the Company accepts no liability if the caravan is altered or modified** in such a way that, in the Company's opinion, the changes would adversely affect the reliability.

You should consult your Dealer before any additional equipment is fitted.

TOWING VEHICLES

- When selecting a towing vehicle for your caravan we strongly recommend you consult THE CARAVAN TOWING GUIDE, which is based on the recommendations of the NCC, and a copy of which is in the information pack provide with this caravan.
- The caravan is manufactured for towing behind normal road cars and is **not suitable for towing behind commercial vehicles**. Providing care is exercised when towing with a 4x4, especially when off road and loading limits are strictly adhered to, then no problems should arise. However, some 4 x 4 pick ups have tremendous rear suspension movement which could, over time be detrimental to the chassis of any caravan, on these we would recommend a shock link is fitted.

REPAIRS

We at Coachman, together with our suppliers, are continually undertaking extensive research into, and testing of, repair procedures and materials such as body sealant, adhesives, gaskets and tapes.

INTRODUCTION

Therefore if you damage your caravan or it should require repairing for any reason, then these repairs must be carried out by an authorised dealer using Coachman genuine parts, recommended sealant and following Coachman procedures.

IMPORTANT

The 17 character VIN of your caravan should be quoted in all correspondence. This number is also shown on the N.C.C. Certificate.

WARRANTY

All Coachman Caravans carry a **five-year manufacturer's warranty**. This warranty applies to the UK and Northern Ireland.

The Coachman warranty does require that a full annual service be carried out by a competent Service Centre. This service must be carried out within 90 days either side of the anniversary of the purchase date for interim years but before the anniversary date on the final year and must include a full damp check. Additionally if customers damage their caravan, or should it require repairing for any reason, then these repairs must be carried out by a competent Service Centre using Coachman genuine parts, recommended sealant and following Coachman procedures.

To activate your warranty your dealer must complete the registration form in the Warranty and Service handbook and return it to Coachman within one week of collection.

WATER INGRESS

We at Coachman recognise that while over recent years we, together with our sealant suppliers, have made tremendous developments in sealants and sealing techniques and are extremely confident in our product resisting water ingress, it is water ingress above all other problems which remains the main worry and concern of potential and actual retail customers.

Therefore, on every new Coachman caravan sold, we make a comprehensive **6 year Worry Free Water Ingress and Delamination Offer:**

- Water Ingress between new and 5 years - All labour and parts covered by the Coachman Warranty provided there is a full service history.
- Water Ingress between 5 and 6 years:
- Coachman will pay the total labour cost and supply parts free of charge provided there is a full service history and the fifth service was carried out before the anniversary date on the final year of the five year warranty.

- When a customer part exchanges a Coachman caravan at a Coachman Dealer and water ingress is detected at the time of the part exchange Coachman confirms they will pay the dealer the total of the agreed cost of any repair undertaken to rectify the water ingress provided:

1. It is being exchanged for a new Coachman Caravan.
2. There is full documentary evidence that the caravan has been serviced annually.
3. The caravan is less than 6 years old.

GENERAL WARRANTY TERMS

The caravan is not covered if the manufacturer's identification (vehicle identification number) of the caravan has been defaced or removed.

The warranty also excludes

- Failure due to reasons of fair wear and tear.
- Damage resulting from accidents.
- Misuse of any component.
- Replacement of parts which have reached the end of their effective working life because of age and/or usage.
- Cleaning or adjustment of any assemblies.

INTRODUCTION

The warranty will be invalidated if the caravan has been neglected, misused or modified in any way without the prior agreement of Coachman Caravans.

The caravan will be deemed to have been neglected if it has not been serviced and maintained as stated in the Warranty and Service handbook.

The warranty also excludes:

- Caravans used for hire or reward.
- Caravans used for other than recreational purposed i.e. for living in or business purposes.
- The cost of transporting the caravan, by whatever means, to the place of repair.
- Any consequential cost or loss arising.
- Damage by mould.
- Damage by forces of nature.
- Damage by vermin.

For full details of the warranty refer to your Warranty and Service handbook.

NOTE: Caravan Movers

Any caravan mover fitted shall comply with the design, fitment and safety requirements of NCC Code of Practice 305. The installation of a caravan mover shall be in accordance with the motor mover manufacturer's installation instructions.

You should ensure you receive a signed installation certificate of compliance from the installer. Failure to do so may invalidate your warranty.

FIRE RETARDENT FOAMS

Under the Condition of the Consumer Protection Act 1987, the manufacturer has a responsibility to ensure that their product is as safe as possible.

With this in mind all caravans are equipped with either Combustion Modified High Resilient (C.M.H.R.) foam cushions or sprung mattresses. (These foams are very much safer from a fire point of view than those previously used. In addition all upholstery is made of fire retardant fabric).

NOTE: Whilst this manual will describe the general operation of the caravan, we recommend that you refer to the individual equipment manufacturers manuals for detailed information.

CARAVAN REGISTRATION AND IDENTIFICATION SCHEME – VIN

The caravan has been security marked and recorded under the Caravan Registration and Identification Scheme that is recognised by the Caravan Industry.

Shortly after purchasing this caravan you should receive your Touring Caravan Registration Document. It will be sent by post to your home address.

Your Touring Caravan Registration Document will include a 17 character VIN (Vehicle Identification Number), shown in the top right hand corner. This 17 character VIN will be die stamped into the caravan drawbar and chemically etched on up to a maximum of 10 eye level windows.

To protect yourself and your touring caravan, never leave the Registration Document in the caravan. For security reasons keep it in a safe place.

If you sell the caravan please follow the instructions on the Touring Caravan Registration Document.

If you do not receive a Touring Caravan Registration Document, lose it, or any of the details recorded are incorrect, please contact:

CRIS
Dolphin House
New Street
Salisbury
Wiltshire
SP1 2TB

Telephone 01722 411430

SECURITY TAG

Two electronic security tags containing the individual identity of your caravan are concealed within the caravan body and can only be read by using a special decoder.

Your local police can obtain the use of a decoder by contacting C.R.I.S. on telephone No: 01722 411430.

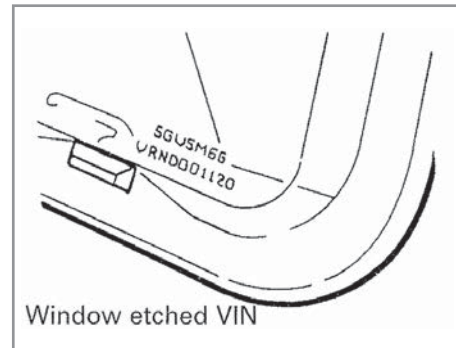

PHANTOM TRACKING SYSTEM

Some Coachman models are fitted with the Phantom Tracking System. This enables the 24 hours Phantom Monitoring Centre to pinpoint the location of the caravan through a global positioning satellite system.

Once the caravan arrives at the Dealers they could choose to call Phantom or simply instruct the customer to do so to register their purchase. There is no longer any connection for the Dealer or customer to make, nor even a need to be with the van to complete the activation.

The caller will simply need to provide their CRIS number to lead us to their device on our database. A simple command from the Phantom server will turn the alerts on and the device will be fully activated in what should be a 5 minute phone call.

The customer will then be alerted as follows.....

Battery disconnected.

Leisure battery running down (triggers about 10v).

Phantom back up battery running low.

Sargent alarm triggering.

In addition the Phantom system will observe the battery voltage and whether the alarm is

armed/disarmed each time we communicate with the tracking unit.

For further details and instructions please refer to the Phantom literature.

The following is a brief description of the main components used in your caravan. More comprehensive descriptions are to be found in the equipment manufacturers' literature held in the wallet with this guide.

AL-KO GALVANISED CHASSIS

The AL-KO chassis fitted to your Coachman is constructed from high quality, hot dip galvanised steel.

The axles and suspension are comprised of 3 rubber elements within a hexagonal tube. Additional Al-Ko Octagon Shock Absorbers are fitted as standard for increased damping and improved road holding.

Note: Holes must not be drilled into the chassis. When purchasing a stabiliser, consult your Dealer who will advise you.

BRAKING SYSTEM

The braking system comprises a rod operated overrunning device with expander mechanism and adjuster box.

An automatic reversing system with a spring-loaded reverse lever is attached to the adjuster box.

The system also incorporates a link device, which gives added safety to the handbrake operation when parking on a reverse slope or steep hill. Brake adjustment should be carried out by your Dealer.

BODY SHELL

Caravan bodies are constructed from the highest quality materials. The floor is constructed from a styrafoam plywood sandwich, impregnated with anti damp and rot compounds and adhesives.

The wall comprises an insulated foam sandwich having a pre-coated aluminium exterior surface and a coated plywood interior finish. Wooden framing is positioned within the sandwich to add strength.

The very latest 'state of the art' presses are employed to produce the extremely well insulated, robust, yet lightweight sections.

Windows are all of a dual glazed acrylic construction and the door frames are extruded aluminium. Fronts and backs are moulded acrylic capped ABS construction for strength and lightness.

Each caravan is fitted, as standard with an awning channel as an integral part of the

aluminium roof and body side moulding. If it is found necessary to fit additional attachments care must be taken to ensure any holes that are drilled in the outside of the body are correctly sealed (this should be carried out only by an approved Dealer/Workshop).

Awnings which employ rubber sucker attachments rather than screw fixings are recommended.

On NO account should screw threads longer than 15mm (5/8th inch) be permitted to enter the shell sandwich (from inside). Ensure that all screws are of the self-tapping type.

All Coachman Caravans are classified as Grade 3 thermal insulation. This means that with an outside temperature of

-15°C the internal temperature can be raised to 20°C within 4 hours of starting the heating.

PLEASE NOTE. While the roof is extremely strong and will take the weight of a person it should not be walked upon without spreader boards as point loads will damage the aluminium. Also if going on the roof all other normal Health and Safety points apply.

EXTERIOR DOORS

Pastiche, VIP and Laser models are fitted with Seitz exterior doors, firstly and most importantly, the door must not be slammed.

When closing the door from the outside, the handle should be pulled and the door pushed to with one hand. With the other hand, pressure should be applied to the front of the handle surround then the handle should be released and you will hear a click. This indicates that the door is shut.

When closing the door from the inside, you should move the lever down, pull the door closed firmly then release the lever.

TOWING CODE

GETTING STARTED

Please refer to the NCC Caravan Towing Guide contained in your information pack prior to your first outing.

TOWING CODE

PAYLOADS FOR UK TOURING CARAVANS

The Code of Practice has been prepared by the National Caravan Council and formulated with input from industry experts. The Code of Practice applies to UK specification Touring Caravans and applies for NCC certification to 2012 VIN onwards Touring Caravans.

The Code of Practice provides for the requirements for European Whole Vehicle Type Approval EWVTA, 2007/46/EC (The Framework Directive) and the directives referenced therein.

PLEASE TAKE CARE TO ENSURE THAT YOU HAVE ALLOWED FOR THE MASSES OF ALL ITEMS YOU INTEND TO CARRY IN THE CARAVAN e.g. optional equipment and personal effects such as clothing, food, pets, bicycles, sailboards, sports equipment etc.

DEFINITION OF TERMS

MAXIMUM TECHNICALLY PERMISSIBLE LADEN MASS (UPPER LIMIT)

This mass takes into account specific operating conditions including factors such as the strength of the materials, load capacity of the tyres, etc. This mass must not be exceeded.

WARNING – UNDER NO CIRCUMSTANCES SHOULD THE MAXIMUM TECHNICALLY PERMISSIBLE LADEN WEIGHT BE EXCEEDED

MAXIMUM TECHNICALLY PERMISSIBLE LADEN MASS (LOWER LIMIT)

The fully laden mass of the caravan in the manufacturer's standard specification which is stated in the publications by the manufacturer for tow car matching.

MRO – MASS IN RUNNING ORDER

Mass of the caravan equipped to the manufacturer's standard specification plus the following

a) LPG

The mass of the recommended gas storage tank(s) when filled to 90% of the permissible maximum capacity.

b) Fluids

The mass of the liquids normally remaining in the systems:

1. Water heater system – 90%;
2. Central heating system – full;
3. Freshwater – the mass of any fixed water storage tank(s) when filled to 90% of the permissible maximum capacity;
4. Toilet system flushing tank – (2kg);
5. Toilet system holding tank – empty;
6. Essential fluids for the use of any other items of standard equipment – full.

c) Electricity supply

4kg for the low voltage connection cable.

THE MASS OF THE CARAVAN IN RUNNING ORDER CONTAINS PROVISION FOR THE MASSES OF LIQUIDS, GAS ETC (SEE MASS IN RUNNING ORDER IN USER HANDBOOK). PART OF THIS PROVISION CAN ALSO BE UTILISED AS ADDITIONAL PAYLOAD IF FOR EXAMPLE YOU WISH TO TRAVEL WITH WATER TANKS EMPTY OR WITH NO GAS CYLINDER.

PERSONAL EFFECTS PAYLOAD

The user payload allows for items common to all occupants, such as food, cutlery, pots, pans, clothing, footwear, bedding, sports equipment etc.

The user payload shall not be less than:

$$10L + 10N + 50(\text{kg})$$

Where:

L is the overall length of the caravan in metres excluding draw gear as give in ISO 612.

N is the sum of all standard and optional berths.

The user payload includes an allowance for auxiliary battery.

OPTIONAL EQUIPMENT

Items made available by the manufacturer over and above the standard specification of the caravan.

The manufacturer shall specify the mass of each factory fitted item of optional equipment available including the mass of any fluids required for their safe and proper use.

Alternatively the manufacturer can specify a maximum optional payload available. The user can then choose any options up to this limit.

In either case this mass shall be added to the user payload.

NOSE WEIGHT

The part of the weight of the caravan supported by the rear of the towing vehicle.

When measuring the nose weight, it is important that the caravan is loaded and level. Do not place extra items indiscriminately into the caravan after this adjustment has been made.

The caravan is intended to be towed slightly nose heavy. The nose weight can be adjusted by distribution of the load within the caravan. You must not exceed the maximum nose weight rating of the hitch head, which is 100kg or that of the towing

vehicle as stated in the manufacturers handbook. **The caravan’s nose weight should be as high as practical; taking into account the towing vehicle and caravan nose weight limits.**

TOWING VEHICLE TERMS

Kerb weight:

The weight of the towing vehicle as defined by the vehicle manufacturer.

The Caravan and Towing Vehicle Weight Ratio

This can be determined by calculation and is equal to:

$$\frac{\text{actual laden mass of caravan}}{\text{kerb weight of towing vehicle} \times 100\%}$$

THE LAW REQUIRES THAT CARAVANS & THEIR TOWING VEHICLES & THE LOADS THEY CARRY MUST BE IN SUCH A CONDITION THAT NO DANGER OR NUISANCE IS CAUSED. (Regulation 100 of the Road and Vehicles (Construction and Use) Regulations 1986).

POWER TO WEIGHT RATIO:

TOWING CODE

No hard and fast rules can be stated but here is a general guide.

- a) Conventional petrol engines with a capacity up to approximately 1500cc should be adequate for towing a caravan weighing around 85% of the kerb weight of the towing vehicle.
- b) Above 1500cc such engines should manage a caravan weighing up to 100% of the kerb weight of the towing vehicle and still give adequate performance.

Note: The towing vehicle manufacturer's limit is, in some cases, less than the kerb weight.

Vehicles with automatic transmission may need an oil cooler fitting or the SAE rating of the gearbox oil increasing when towing. The

advice of the vehicle manufacturer should be sought.

MEASUREMENT OF NOSE WEIGHT:

Nose weight may be measured using a proprietary brand of nose weight indicator. Such equipment is obtainable at your caravan Dealer.

Another simple method is to use bathroom scales under the coupling head with a piece of wood between the coupling head and the scales, of such length that the caravan floor is horizontal with the jockey wheel raised.

Nose weight can be adjusted simply by distribution of weights in the caravan.

(See Loading)

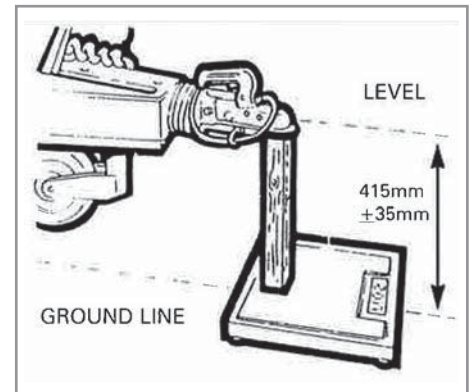
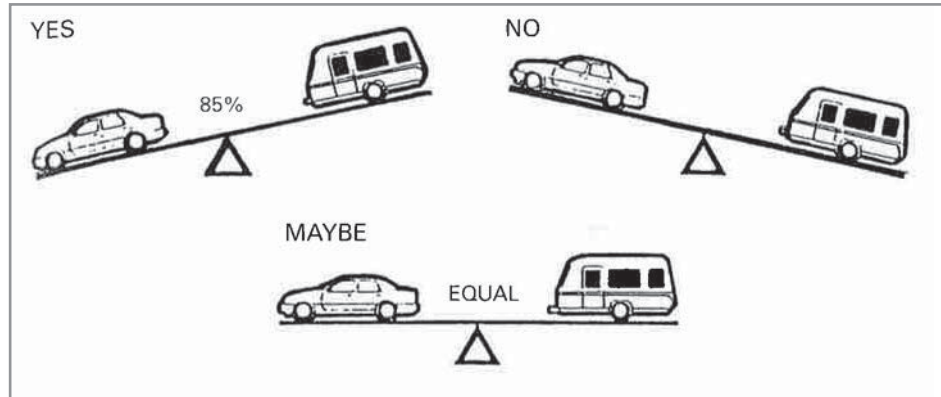

In order to be able to tow a caravan a driver must hold a Category B licence. Those car drivers who passed their tests prior to 1 January 1997 would have automatically obtained Category B + E. However, anyone who passed their test after 1 January 1997 will need to take a further test in order to obtain a Category B + E if they wish to tow a car and caravan combination whose train weight exceeds 3,500kg, or up to 4,250 if the caravan is less than 750kg or if the caravan's Maximum Technically Permissible Laden Mass exceeds the unladen weight of the car.

Note: The unladen weight of a car is normally less than the kerbside weight.

If you are unsure contact the DVLA at Swansea for further details.

Compulsory Third Party Insurance cover is required by the Road Traffic Act for a caravan and this is normally provided by the towing car Insurance Policy, but it is essential that you ensure your car Policy is not invalidated by towing.

Do not forget to take out separate Insurance Cover on the Caravan and Contents.

LOADING AND DISTRIBUTION OF WEIGHT

Under no circumstances should the MTPLM of the caravan be exceeded.

When the towing vehicle and caravan are fully laden and "ready to go" the towing vehicle should be level fore and aft. If the nose of the caravan is high at the start of your journey you may experience snaking and on rough and uneven ground the rear of the caravan could catch the road.

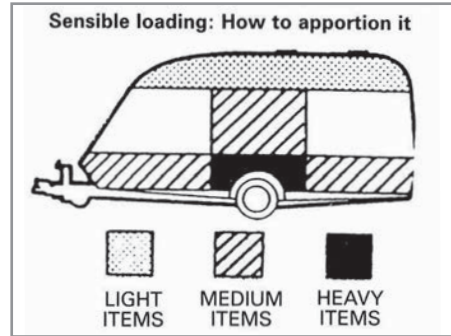

Caravans should be loaded so that the nose weight of the caravan is in accordance with the tow vehicle manufacturer's recommendation. **Also under no circumstances should it exceed the maximum hitch weight shown in the specification for the caravan.**

Heavy items should be stowed as close to the axle as possible and lightweight items, such as bedding, should be loaded at the rear. Try to stow bulky tinned supplies in the lower kitchen cupboards or even in the bottom of the bed boxes until you arrive at your final destination. Please note that the roller catches and spring loaded doors are only to keep the door closed and not to stop items falling out of lockers and on to work surfaces. Only light items should be stowed high up in the roof lockers. Ensure that all items are secure and will not move around while on tow.

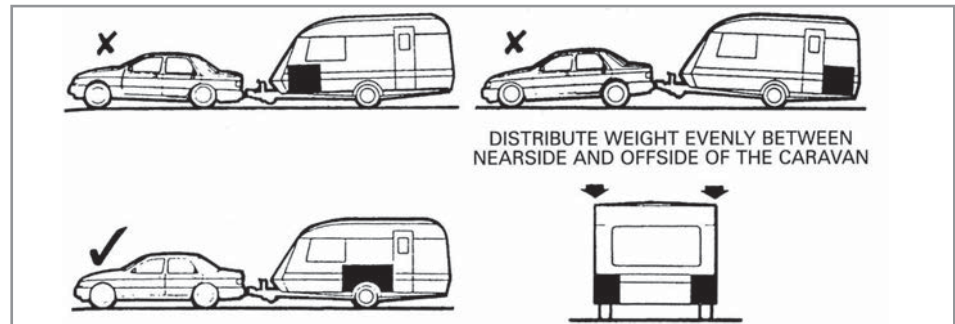

PREPARING FOR THE ROAD

Towing vehicle's rear suspension

It is important that the towing vehicle's rear suspension is not deflected excessively by the nose weight on the tow ball. If it is excessive the steering and stability will be affected.

The greater the towing vehicle's tail overhang (the distance between the rear axle and the tow ball) the greater the effect the nose weight will have on the towing vehicle's rear suspension.

After trying out the caravan it may be found that stiffening of the vehicle's rear suspension is necessary – note that this may give the towing vehicle a firmer ride when not towing.

There are a number of suspension aids available and advice should be sought on which to use and how to fit.

It is important to ensure that the caravan is towed either level or slightly nose down. This is particularly important on twin axle models.

STABILITY

The most common causes of poor stability include:

- a) Worn springs or loose spring fixings on the towing vehicle.

- b) Towing vehicle springs too soft.
- c) Insufficient nose weight.
- d) Nose of caravan is towing too high.
- e) Incorrect loading.
- f) Incorrect tyre pressures on car or caravan.

Tyres and Pressures

The tyres fitted to your caravan will operate with complete safety at the UK maximum speed limit of 60 mph, but the tyres are rated to 130 km/hr. The tyres on your caravan must be operated at the pressures indicated on the caravan's specification sheet. Remember that the towing vehicle tyres should be inflated to the 'heavy loaded' pressure given in the vehicle manufacturers' service handbook.

Note: Pressures should only be checked when the tyres are cold, not after a journey or if the vehicle has been standing in the sun.

Tyre Tread

This caravan is subject to the same criteria applied to car tyres, namely, the minimum tread should be 1.6 mm around the total circumference and across the entire width of the tyre.

Brakes/breakaway cable

A breakaway cable is fitted so that in the case of the caravan becoming detached from the car it immediately applies the brakes. Always ensure the breakaway cable is secured to the towing vehicle. See Page 20

SNAKING

This is a term used to denote an unstable car and caravan combination where the caravan 'weaves' from side to side often causing a similar swaying movement in the car itself.

Causes:

- I. Unsuitable or unbalanced outfit.
- II. Incorrect loading or weight distribution.
- III. Excessive speed especially downhill.
- IV. Side winds.
- V. Overtaking
- VI. Being overtaken by a large fast moving vehicle.
- VII. Erratic driving.
- VIII. Insufficient tyre pressure.

Cures:

Cases of persistent snaking can be alleviated or even completely cured by various proprietary devices, about which your dealer will advise you.

PRE-TOW CHECKLIST AND HITCH-UP

CAUTION: Never enter the caravan without first lowering the four corner steadies with the brace provided. Corner steadies should not be used as a jacking device, or to take the weight of the caravan.

Loose articles must be stowed securely. Do not stow tins, bottles or heavy items in overhead lockers prior to towing.

- ensure all lockers and cupboard doors are closed and secured.
- all bunks are secure.
- all rooflights are closed and secured.
- tables are stored in their transit positions.
- fridge is on 12v operation and door travel catch is set.
- all windows are fully closed and latched.

Never tow with windows on night setting.

Leave all curtains and blinds open to aid rear visibility.

- gas cylinders and appliances are correctly positioned, secured and turned off.
- battery is secure and mains connecting cable is disconnected and stowed.

Check Gas Locker, Battery Locker, Wet Locker and Cassette Toilet doors are secure.

Check wheel bolts, tyre pressures and tyre conditions.

Lock the entrance door

Suitable towing vehicles

The caravan is manufactured for towing behind normal road cars and is not suitable for towing behind commercial vehicles other than passenger car derivatives. If in doubt please contact your caravan Dealer.

STABILISERS AND TRACTION CONTROL

All Coachman Caravans come fitted with a stabiliser. It can make a good towing vehicle/caravan combination safer to handle. A stabiliser should never be used to try to

improve a combination, which has poor stability, since instability will reappear at a higher speed.

Note: Under no circumstances should holes be drilled into the chassis members e.g. for fitting additional equipment.

Coachman Caravans are also equipped for the fitment of the Al-Ko Trailer Control System (ATC) and some models have it fitted as standard

The Al-Ko ATC is the emergency braking system for caravans and works in a similar way to ESP systems for cars. The sophisticated, but simple electronic system monitors the lateral movement of a caravan during travel. When difficult driving conditions are experienced, such as evasive manoeuvring, high side winds and turbulence encountered while overtaking HGV's, Al-Ko ATC take control to regain stability and prevent dangerous snaking accidents.

ATC OPERATING INSTRUCTIONS

After coupling the caravan correctly to the towing vehicle, connect the 13 pin plug to the tow bar.

PREPARING FOR THE ROAD

Upon connection, ATC will carry out an initial self test and the LED light on the front fairing will light up RED. During the self test, the sound of the push rod moving inside ATC can be heard. When the self test is complete, the LED will turn GREEN or flashing GREEN to signal that ATC is active.

If the LED does not change to GREEN, then ATC is not functioning correctly. The table provided see Page no 15 details what to do in this case.

Important - A20 amp fuse is required on the actual towing vehicle on the constant 12v supply. Please check with your Vehicle Dealer/Towbar installer. If only a single fuse is fitted at the tow bar a minimum fuse rating of 25 amps must be used.

Note: When providing power from an independent supply e.g. a portable power pack it is necessary that a battery rated at least 12V 55 Ah is used to supply the auxiliary feed. It is also important that the power supply is fused at 20 amps.

Always re-check the ATC LED is green after any interval during a journey, such as a service station break.

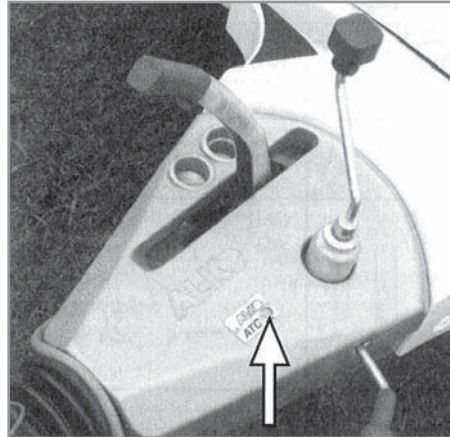

ATC LED light on the fairing

TROUBLESHOOTING

Should you experience a fault with ATC, the LED light on the fairing will change colour. Therefore, refer to the table above and follow instructions.

If no illumination of the LED is evident, refer to system requirements and check tow bar wiring for permanent supply.

In the unlikely event that you receive a red flashing LED light and disconnecting and re-connecting the power does not alleviate the problem, check the push rod position as detailed right.

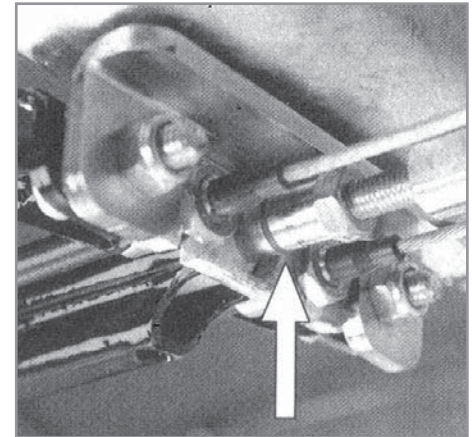

Locate ATC on the axle and check to position of the push rod. (See photograph above).

If no red line is visible, ATC is not active and can be driven. However, we recommend that you contact Al-ko at the earliest convenience.

If the red line is visible on the push rod, as shown on the left, the caravan should not be moved.

Contact Al-ko or a specialist workshop.

LED OPERATION

Display Colour	ATC Condition	Diagnosis	What to do	Outcome	Status
Green	ATC Active	Everything OK			
Green Flashing	ATC Active	Self test incomplete	Drive forward to detect movement to complete self test and re check LED	Green (Constant)	Ready for journey
Red	ATC Inactive	Possible to continue journey.	Remove 13 pin plug and wait 5 seconds. Reconnect plug	Green Red	Ready for journey. ATC faulty but can be driven. Consult Al-ko. See back page of Al-ko handbook for details
Red flashing	ATC has detected a fault	Do not continue with ATC connected	Remove 13 pin plug and wait 5 seconds. Reconnect the plug.	Green Red (flashing)	Ready for journey. ATC faulty and cannot be driven. Remove push-rod as shown on page 5 of Al-ko handbook. Consult Al-ko. See back page of Al-ko handbook for details.
LED not working	ATC has no power. LED faulty	Check push rod position as detailed on page 5 of Al-ko handbook before continuing journey.	Remove 13 pin plug and wait 5 seconds. Reconnect the plug. Check for constant live – refer to system requirements as detailed on page 3 of Al-ko handbook.	Green. LED not working.	Ready for journey. If power ok, check push rod position. Red line visible – possible to continue journey but consult Al-ko. See back page of Al-ko handbook for details.

Prior to commencing any journey, ensure that the caravan lighting is fully operational and check the vehicle is loaded appropriately, the nose weight and tyre pressure are correct and confirm that the caravan is coupled to the vehicle tow bar correctly.

PREPARING FOR THE ROAD

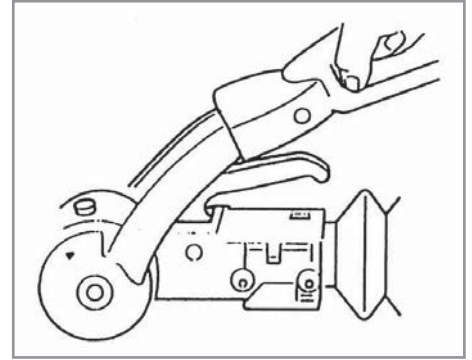
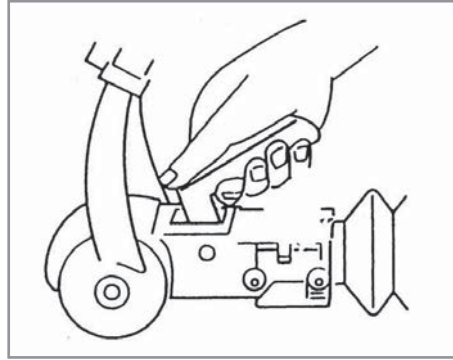
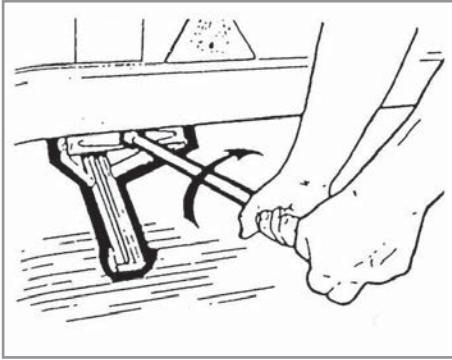

HITCHING UP

Wind up the corner steadies to the fully retracted position.

Wind up the jockey wheel to raise the hitch to the above height of the towing vehicle ball. Remove ball cover.

(It is an advantage to have a person standing by the caravan to direct the driver of the towing vehicle to place the vehicle in the correct position).

Reverse the towing vehicle so that the towing ball is just under the caravan hitch.

Operating Instructions – AKS 3004

The AKS 3004 stabiliser fitted to your caravan has 4 special friction pads, which suppress both snaking and pitching and it is essential that the tow ball is kept completely clean as contaminated pads will reduce its effectiveness.

The maximum vertical static load for this coupling is 100kg and must not be exceeded. However, the vertical static load on the towing vehicle may be less than this (check with towing vehicle manufacturer).

Whichever is the least must not be exceeded.

To hitch up with the AKS 3004 follow the following procedure:

- Using the coupling handle (which should be in the upright position), put the AKS on

to the towball. Push the black handle down and check the green indicator button is showing. **(Fig. 1)**

- Press the red stabilising lever down. The AKS is now ready for the road. **(Fig. 2)**

Safety Indicators

- If the green indicator is visible then you know you have correctly coupled your AKS to your towing vehicle. **(Fig. 3)**

Wear Indicator

For coupling mechanism and front/rear friction pads. **(Fig. 4)**

- Wear of the coupling ball and mechanism can be easily monitored. If the green section is visible (when coupled to your towball) then the front/rear friction pads, coupling ball and mechanism are in order.

- If the red lower section obscures the green section then you need to check these parts immediately.

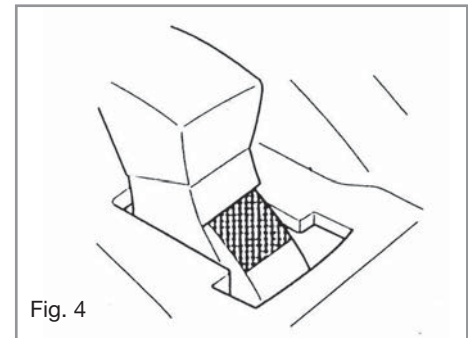
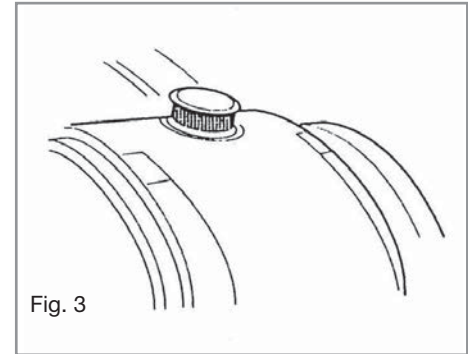
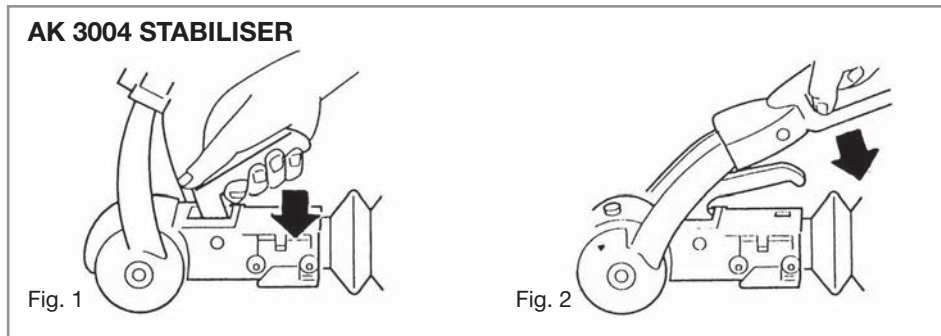

PREPARING FOR THE ROAD

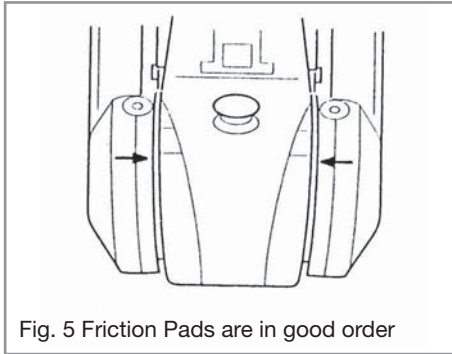

Fig. 5 Friction Pads are in good order

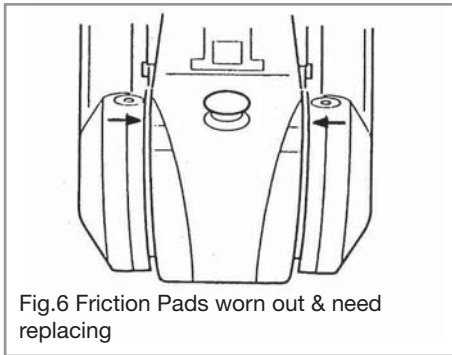

Fig.6 Friction Pads worn out & need replacing

Friction Pads Replacement

- Unscrew the 2 screws which are under the red rubber soft dock by using the special tool. **(Fig. 7).**
- Remove screw from back plate. **(Fig. 8)**
- Remove friction pads. **(Fig. 9)**

Loading capacity

The AKS 3004 can tow vehicles up to gross weight of 3000kg and a maximum nose weight of 100kg.

UNCOUPLING

Lower the jockey wheel to the ground. Disconnect the breakaway cable and plugs.

Release stabilising lever and lift the coupling handle whilst winding.

Lift the coupling head clear of the towball.

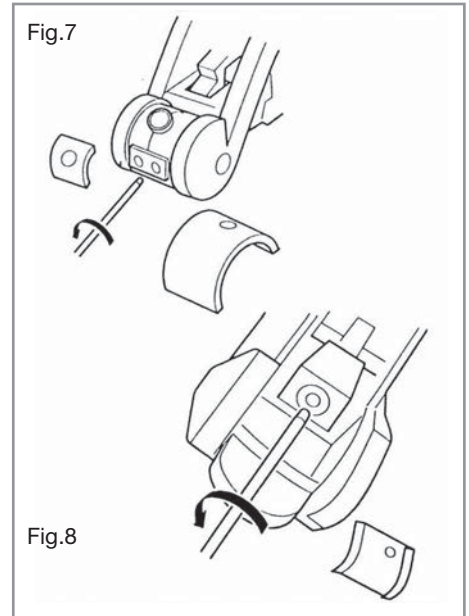

Fig.7

Fig.8

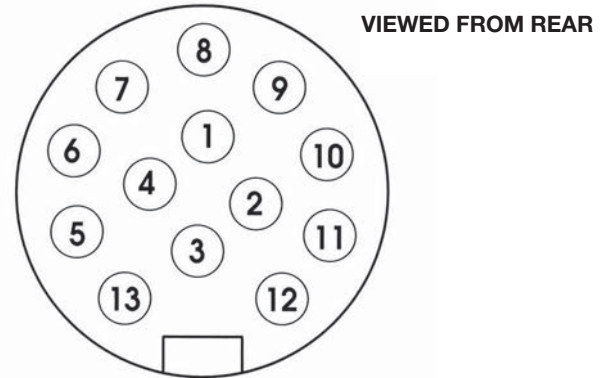

Fig. 9

Electrical Connections and Road Lighting

Plug in the 13 pin electrical connections and check that all road lights work.

In accordance with EN150 11446 your caravan is fitted with a 13 pin Jaegar plug for electrical connections and road lighting. If your car is fitted with the old type 12N and 12S sockets we would strongly recommend that you do not use adaptors but have it rewired and a 13 pin Jaegar socket fitted. (Ensuring the car socket is wired in accordance with the drawing on the right).



PIN NO	COLOUR	DESCRIPTION
1	Yellow	Left Flasher
2	Blue	Fog Hazard Light
3	White	Return for 1,2,4,5,6,7 & 8
4	Green	Right Flasher
5	Brown	Right Tail Light
6	Red	Stop Lights
7	Black	Left Tail Light
8	Orange	Reverse Lights
9	Brown/Blue	Car +
10	Brown/Red	Fridge
11	White/Green	Return for 10
12	NOT USED	
13	White/Blue	Return for 9

PREPARING FOR THE ROAD

BREAK-AWAY CABLE

UK LAW requires that all trailers with brakes built on or after 1st October 1982 (e.g. caravans, horse boxes, flat bed car trailers etc.) are fitted with a safety device to provide protection in the unlikely event of the separation of the main coupling while in motion. A device referred to as a “breakaway cable” fulfils this requirement and when fitted to a trailer its use is mandatory.

Purpose – To apply a trailer’s brakes if it becomes separated from its towing vehicle. Having done this, the cable assembly is designed to part, allowing the trailer to come to a halt away from the towing vehicle.

Construction – Usually a thin steel cable, possibly plastic coated, and fitted with a means of attachment for connection to the towing vehicle.

Operation – In the event of the main coupling of the trailer separating from the towing vehicle, the cable should be able to pull tight, without any hindrance, engaging the trailer’s brakes.

Note: The breakaway cable should never become taut during normal use.

Correct procedure for use:

- Regularly check the cable and clip for damage. If in doubt, contact your dealer or service agent.
- Make sure the cable runs as straight as possible and goes through a cable guide underneath the trailer coupling.
- Determine whether or not the towbar has a designated attachment point (i.e. a part specifically designated by its manufacturer for a breakaway cable).

Where a designated attachment point is provided on the towbar:

- Pass the cable through the attachment point and clip it back on itself (**Fig 1**).
- Do not attach the clip directly to the designated point (**Fig 2**). The clip is not sufficiently strong enough for use in this way.

Where no designated attachment point has been provided on the towbar:

Fixed ball – Loop the cable around the neck of the towball. If you fit the cable like this, use a single loop only. (**See Figs 3A and 3B**).

Detachable ball – You must seek guidance on procedure from the towbar manufacturer or supplier.

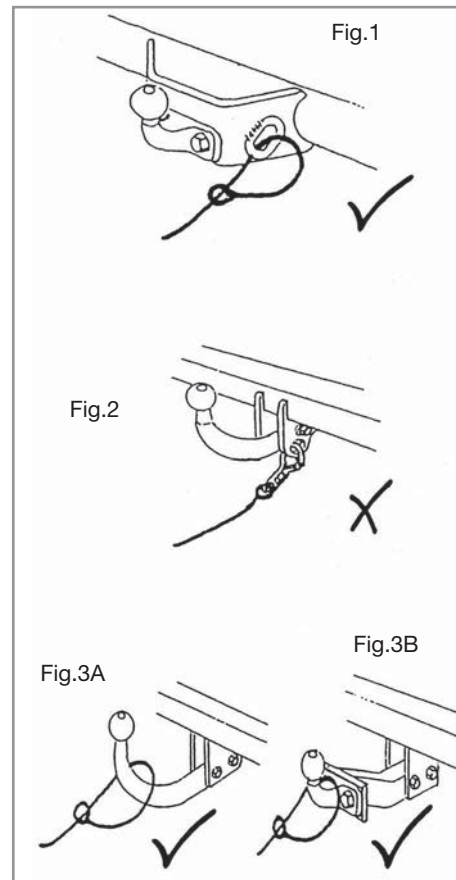

Other means of attachment –

In some instances it may be possible to attach the cable assembly:

Either:

a) to a permanent part of the towbar structure, as long as this meets the approval of the towbar manufacturer/supplier,

Or

b) to an accessory sold for the specific purpose of breakaway cable attachment.

When the breakaway cable is attached, check to ensure:

- a) that the cable cannot snag in use on the trailer coupling head, jockey wheel, or any accessory e.g. a stabiliser, bumper shield, cycle carrier, etc.
- b) that there is sufficient slack in the cable to allow the towing vehicle and trailer to articulate fully without the cable ever becoming taut and applying the brakes.

Note: For peace of mind you might wish to check the state of the cable by positioning the trailer and towing vehicle at extreme angles before setting off.

c) that it is not so slack that it can drag on the ground. If left loose, the cable may scrape along the ground and be weakened so that it subsequently fails to

do its job. The cable may also be caught on an obstacle when in motion thus engaging the trailer brakes prematurely.

Having followed this advice, should you feel that a satisfactory coupling arrangement cannot be achieved, consult your Dealer

MIRRORS

There is a legal requirement for you to have mirrors that allow you to see clearly an area that is 4 metres wide from the side of your caravan at a distance 20 metres behind the driver. A caravan is significantly wider than a car even a large 4 x 4 and you simply can't comply with the law unless you fit towing mirrors. The driver of the towing vehicle must have an adequate view of the rear.

If there is no rear view through the caravan it is essential that additional exterior towing mirrors are fitted.

Caution: Any rear view mirror must not project more than 250 mm* outside:

- a) the width of the caravan when being towed.
- b) the width of the towing vehicle when driven solo

*The limit for older vehicles is 200 mm

Note: Any rear view mirror fitted shall be 'e' marked and cover the field of view as stipulated by type approved requirements (Regulation 33 of the Road Vehicles Constructions and Use Regulation 1986).

COUPLING UP A CARAVAN CHECK LIST

1. Is the hitch fully down over the tow ball?
2. Is the hitch head lever fully closed (down)?
3. Are the visual indicators showing green?
4. Is the breakaway cable correctly attached, passing through the cable guide, loose but not dragging, and will not snag on full lock?
5. Is the stabiliser correctly attached, with the handle closed and indicators green?
6. Is the jockey wheel fully retracted and stowed away securely?
7. Are the electrics correctly attached and free from dragging or snagging on full lock?
8. Have the lights and road indicators been checked and are they working?

PREPARING FOR THE ROAD/TOWING AND DRIVING

9. Once “Hitched Up”, are the corner steadies fully retracted, and the caravan handbrake OFF?
10. Has the caravan step been stowed away?
11. Are the caravan door, windows, lockers and roof lights closed and secured?
12. Is the rear number plate correct and clearly visible?
13. Is the gas system turned off for towing.
14. If fitted check ATC system. (See Page 14).
15. Is the caravan loaded correctly and all items secure?
16. Is the sink empty of all items including the bowl?

SPEED LIMITS

Normal road towing: 50mph (80 kph)

Motorways (including
Dual carriageways): 60mph (96 kph)

PULLING OFF

Let the clutch out smoothly.

Allow more engine speed to produce the power to move the additional weight of the caravan.

Avoid wear and tear on clutch and transmission by taking extra care.

Change gears smoothly.

Try not to jerk the clutch.

CARAVAN HANDLING

Allow for caravan being wider than car.

Do not bump kerb with caravan wheels.

When passing other vehicles allow more than normal clearance for driving solo.

Allow longer to get up speed to pass.

Allow for the vehicle being twice its normal length.

Do not suddenly swing out.

Carry out all manoeuvres as smoothly as possible.

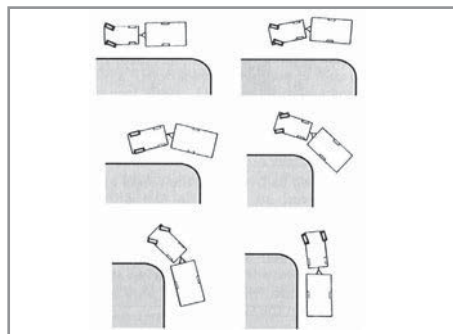

Use nearside wing mirror to check caravan has cleared when overtaking.

REVERSING

It is advisable to have a second person available when reversing the caravan. Start practising by choosing a left-hand bend for ease. Reverse slowly, turning the wheel, initially the opposite way to the direction you want the caravan to go.

Now the front of the caravan is nudged out and moving the rear in the intended direction. Take care not to hit the van with the car!

Midway through the manoeuvre, when the caravan is correctly angled, slow to a crawl and gradually apply opposite lock. Make the car follow the caravan round then finally straighten up.

CARE MUST BE TAKEN TO PREVENT FOULING WHEN TRAVERSING RAMPS OR OTHER GROUND OBSTACLES

Caravans may not be towed in the outside lane of a three or four lane motorway. (Ref. 12(2) of the Motorway Traffic (England and Wales) Regulations 1982)

Proficiency at reversing can only be achieved with practice.

MOTORWAY DRIVING

1. Reduce Speed:

- i) In high or cross winds.
- ii) Downhill.
- iii) In poor visibility.
- iv) Poor road conditions

2. High sided vehicles cause air buffeting so extra care must be taken when passing or being passed. As much space as possible should be given.

CHANGING A WHEEL

1. Unhitch the caravan and ensure handbrake is applied.
2. Lower the front of your caravan by retracting the jockey wheel as much as possible.
3. Lower the corner steadies, as a safety measure, to stabilise the caravan.
4. Your spare wheel is located in the AL-KO spare wheel carrier situated just behind the axle.
5. To remove the spare wheel from the carrier locate hand wheel situated on the centre of the spare wheel carrier retaining plate on the nearside of the chassis and remove the split ring in the hole at the end of the bolt. Now loosen

and remove the hand wheel.

6. Now slide the carrier out of the locating holes on the chassis and rest the nearside on the floor.
7. Reach into the centre of the spare wheel and remove the clamping sleeve and the retaining wheel nut. Remove spare wheel from carrier.
8. Use your wheel brace to slacken off the wheel bolts on the wheel to be changed.
9. If your caravan has a jack receiver fitted,

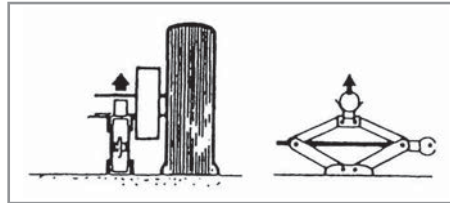

then jack up the caravan in line with the instructions. If not position a suitable jack under the axle at the appropriate jacking point (rear axle on twin axle models).

10. Jack up caravan until the wheel to be removed so that it is just off the ground.
11. Remove the wheel bolts and remove the wheel.
12. Fit spare wheel and reverse the above

procedure placing the punctured wheel in the wheel carrier.

WARNING – Ensure the wheel is of the same construction and size with the one that has been removed.

13. Tighten all bolts equally in order shown in the diagram.

Torque settings are:

Steel Wheels 88Nm (65 lbs/ft).

Alloy Wheels 130Nm (96 lbs/ft).

WHEEL BOLT TIGHTENING SEQUENCE

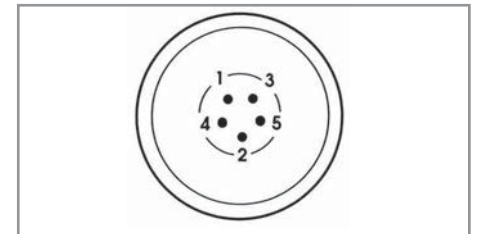

WARNING:

1. After the first 30 miles check all road wheel bolts and tighten, if required, to correct torque setting.
2. Check wheel bolt torque before each major journey.
3. Never use grease of any kind on wheel bolts.

SAFETY AND SECURITY

Please note with Alloy Wheels you should first tighten all bolts to 85Nm (63lbs/ft) then go around again in the sequence shown and increase the torque from 85Nm (63lbs/ft) to 130Nm (96lbs/ft).

IMPORTANT: Your attention is drawn to the notice affixed in the caravan advising on fire prevention, ventilation and what to do in case of fire.

CHILDREN

Do not leave children alone in the caravan. Keep potentially dangerous items, e.g. matches, drugs etc, out of reach, as at home.

FIRE EXTINGUISHERS

It is recommended that you provide, one dry powder fire extinguisher, of an approved type or complying with ISO 7165 of at least 1kg capacity by main exit door, and a fire blanket next to the cooker. Familiarise yourself with the instructions on the fire extinguisher and the local fire precaution arrangements.

A fat pan must not have an extinguisher aimed at it, but must be smothered by a fire blanket.

IN CASE OF FIRE

1. Get everyone out of the caravan as quickly as possible using whichever exit is

quickest including windows. Do not stop to collect any personal items.

2. Raise the alarm. Call the fire brigade.
3. Turn off gas container valve if safe to do so.

VENTILATION AND CONDENSATION

All caravans comply with EN 1645-1. The ventilation points on your caravan are fixed points of ventilation, which are required by the European Standards. Low level ventilation is located at various points. High level ventilation is through the roof lights. Under no circumstances must these vents be blocked or obstructed.

WARNING

Never use portable cooking or heating equipment, other than electrical heaters that are not of the radiant type, as it is a fire and asphyxiation hazard.

Petrol/Diesel Fumes

The fitting of a tail pipe to your exhaust will reduce the possibility of fumes entering your caravan through the front fixed ventilation points.

It is advised that fixed ventilation points are checked and cleaned (if necessary) on a regular basis.

SECURITY VIN (VEHICLE IDENTIFICATION NUMBER)

Record your caravan V.I.N. which can be found stamped on the underside of the drawbar or on one of the eye level windows. Make a note of this number in the space provided at the front of this guide and make a separate note of the number to keep safe at home.

CARAVAN THEFT

The theft of a caravan can occur in the most unlikely circumstances; from a motorway service area, even from an owner's driveway.

Secure all windows and doors when your caravan is unoccupied, even if only for a short length of time.

ADDITIONAL SECURITY

Laser and VIP models come as standard with the AL-KO Secure wheel clamping device. While Amara and Pastiche have the AL-KO Secure receiver fitted as standard and the AL-KO Secure device can be purchased from your dealer, alternatively consider fitting any device, which might deter or prevent intrusion by thieves. A hitch lock cover prevents towing of the caravan.

FITMENT OF AL-KO SECURE

- Align the wheel so that the receiver can be seen in the centre of the rim opening. DO NOT use the rim opening in which the tyre valve is fitted. **(Fig 1)**
- Unscrew the plastic cap from the receiver and store in the tool kit box. (When AL-KO Secure is not in use, always screw the plastic cap in place). **(Fig 2)**
- Insert the locking bolt into the rim specific insert. **(Fig 3)**
- Insert the locking bolt socket key. **(Fig 4)**
- Line up the locking bolts and assembly with the receiver. **(Fig 5)**
- Tighten the locking bolt socket using the wheel spanner provided (or torque wrench as shown) to wheel torque (Ideally 86 Nm). **(Fig 6)**
- Remove the locking bolt socket key. **(Fig 7)**
- Insert barrel lock. **(Fig 8)**
- Hold the lock fast and lock. **(Fig 9)**
- The AL-KO Secure is now fitted. **(Fig 10)**

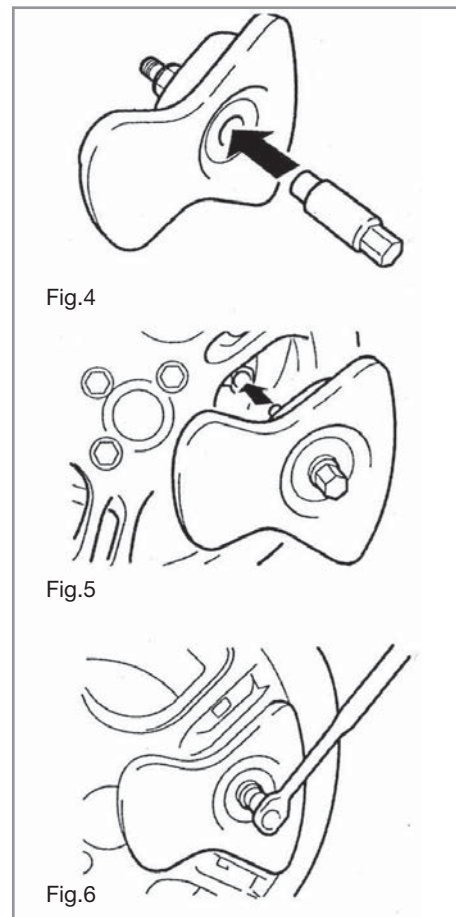
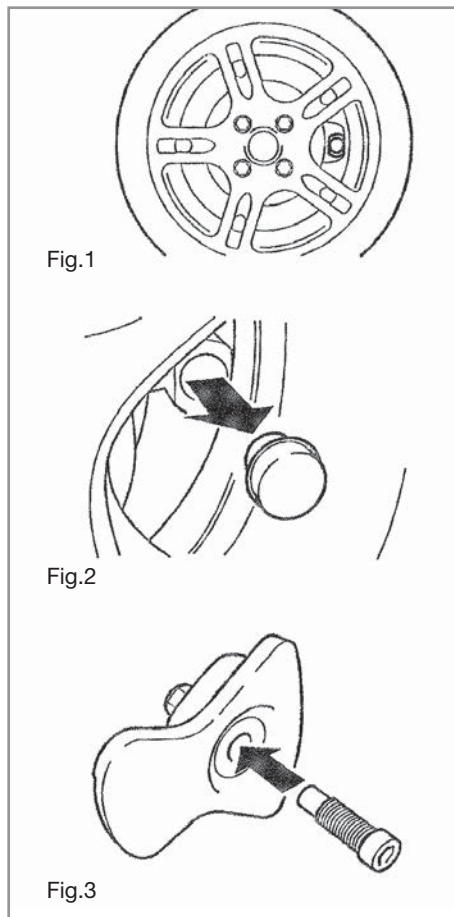

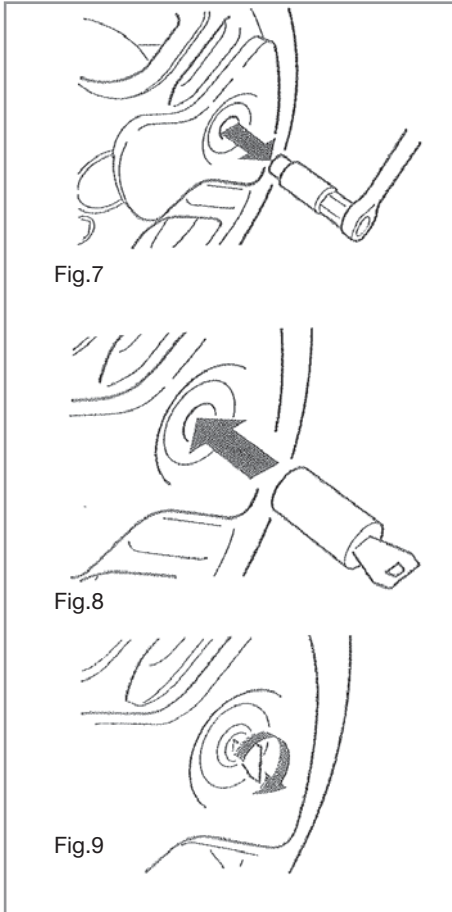

Fig.7

Fig.8

Fig.9

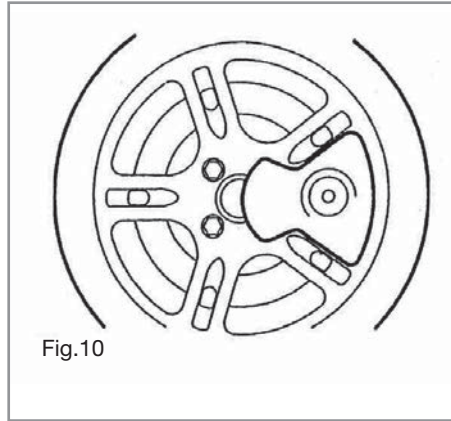

Fig.10

TWIN AXLE CARAVANS

Fit the front lock first by aligning the wheel so the receiver can be seen in the centre of the rim opening. Chock front wheel and opposite wheel. Jack the caravan (preferably using the AL-KO side lift jack) until the rear wheel is clear of the ground. Fit the second lock by aligning the wheel as described previously.

FREE CRIME PREVENTION

Advice on securing your caravan, protecting your valuables, property marking, either at home or whilst on site, can be obtained from the Crime Prevention Officer through your local Police Station.

CHECK SITE REGULATIONS FOR ANY LOCAL RESTRICTIONS

SELECTING A PITCH

Carefully select where you wish to place your caravan. The site should be as level as possible, preferably not under or near trees, well drained and away from possible boggy areas. Consider how you will move the caravan when it is time to leave the site. On sloping ground it is better to pitch facing downhill, especially during wet weather.

It should be noted that some items of caravan equipment are only designed for use up to a 3 degree angle and if this angle is exceeded the components may fail.

It is good practice to chock the wheels of the caravan when parked on a slope even though the caravan brakes are applied.

UNHITCHING

Apply the caravan handbrake.

WARNING

Attention: Always disconnect the 13 pin plug between the towing vehicle and the caravan before connecting an LV (230V) supply to the caravan and before charging the caravan battery by any other means.

Disconnect the breakaway cable.

Disconnect the 13 pin plug and return it to its holders.

Unclamp and lower the jockey wheel to the ground.

Release the stabilising lever and coupling handle.

Operate the handle to wind down the jockey wheel until the coupling head clear of the towing ball.

Replace towball cover.

Park your vehicle alongside the caravan on the offside.

LATERAL LEVELLING

On uneven ground lateral levelling may be accomplished by the use of a leveller jack and a spirit level placed 'across' the caravan floor.

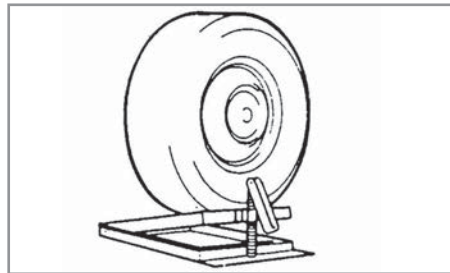

Place the leveller jack, folded flat, in front of the wheel needed to be raised to level the axle.

Tow the caravan onto the leveller jack. Wind up until the spirit level shows that the caravan is laterally level. Apply the caravan handbrake and chock the caravan wheel if necessary. Lower the jockey wheel to ground level.

Proceed with unhitching as described above.

(On upward facing pitches when the hydraulically damped drawbar of the hitch becomes fully extended it will be necessary to compress the drawbar slightly in order to achieve a 'clean' unhitching). With the caravan brake on, reverse the towing vehicle about 1 inch (2.54cm) to release hitch lock tension and using the jockey wheel adjustment unhitch the caravan as previously described.

Note: Under no circumstances should the caravan steadies be used as a jack. They are only a means of stabilising the caravan.

ARRIVAL AT SITE/CONNECTING SERVICES - WATER

FORE AND AFT LEVELLING

Place the spirit level 'fore and aft' and using the jockey wheel adjustment level the caravan horizontally.

Wind down the corner steadies onto load spreaders (blocks of wood a minimum of 6 inches (15.25cm square) taking care not to lift the caravan wheels.

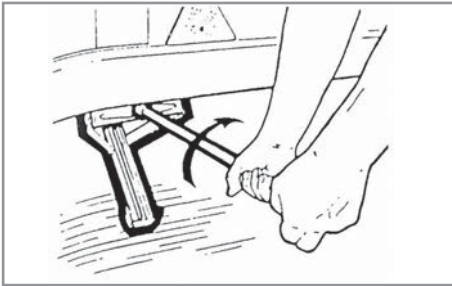

It is important that the caravan is correctly levelled to ensure the correct working of the refrigerator, cooker etc.

Your caravan should not be operated at an angle greater than 3 degrees.

Caution: Never enter the caravan without first lowering the four corner steadies with the brace provided. Corner steadies should not be used as a jacking device.

PARKING ON A REVERSE – SLOPING SITE OR STEEP HILL

For successful parking on a reverse slope or steep hill, the operator need only apply the handbrake with one hand while gently but purposely inching the caravan or trailer a small distance backwards with the other.

WARNING: If the handbrake is NOT fully applied (i.e. vertical) and is set to some lesser position than the full vertical, then problems will almost certainly arise after the trailer has been uncoupled from the towing unit. On steep hills or sloping sites always chock the caravan wheels.

CONNECTING SERVICES

Connection of services is dealt with under separate headings. **In all cases become familiar with manufacturers' instructions.**

Before making connections of any description to the caravan ensure ALL equipment is turned off and that where appropriate switches are moved to the off positions.

WATER

Your caravan will be fitted with a Truma Ultraflow Filter water system and on Laser models this is combined with a Whale Underfloor Tank System. To determine which model you have, please refer to the Coachman brochure.

Under no circumstances should mains water be connected to the caravan without a pressure reducer.

If using the system after a storage period, carry out checks as outlined in "Setting up the Water System".

Fill fresh water container and place in suitable position. Place waste water receptacles in position.

Place the submersible pump or filler pipe (dependant on system) into the water container, ensuring that it is fully submerged before operating the system.

WASTE CONNECTION

Your caravan is fitted with a 28mm waste water system. Two waste water outlets are located on the offside of the caravan to the rear of the wheels. These outlets connect to standard waste hose, which can then be inserted into suitable waste water containers.

PRESSURISED WATER SYSTEM

Fresh water is supplied to the caravan from an external water container by the Ultraflow Filter Compact System, which consists of a socket located near the water heater cowl, on the offside of your caravan and a separate plug-in pump assembly. The socket is protected by a hinged lid which should be kept shut when the pump is not connected. The lid is easily opened by gripping the lower edge and pulling outwards. The separate plug-in pump assembly consists of a submersible pump, hose and plug. The plug provides connection to both water supply to the caravan and 12 volt DC electric power to the pump. A dust cover is fitted to the connecting dual hose to prevent contaminants falling into the water container.

TRUMA ULTRAFLOW FILTER HOUSING

The Truma Ultraflow Filter Housing is part of a unique, high quality product range designed to bring water to your caravan in a convenient and efficient manner.

The system includes a special filter which removes unpleasant tastes, smells and suspended particles to give clear, fresh tasting water.

The activated carbon, which removes chlorine, tastes and smells, etc., by absorption and by mechanical filtration reduces algae and bacteria. The silver content avoids bacteriological growth in the filter.

Truma Ultraflow operates in the caravan water supply as a **pressurised system**. The **Truma Surge Damper** includes an **electronically controlled pressure switch**. The pressure switch turns the water pump on and off regardless of the momentary atmospheric pressure and battery power (between 10v and 14v).

Also available on some models is a special outdoor shower which connects directly beside the pump.

The water pump and outdoor shower are detachable from the Ultraflow Filter Housing for security and while touring. A blanking plug is available to blank off the inlets when the pump or shower is not attached.

To connect the pump, simply align the plug with the socket and push it into position. This makes both water and electric connections.

The shower plug contains no electrical connections.

To remove, pull the lower trigger and pull the plug from the socket.

OPERATING INSTRUCTIONS

Raise the lid, clean both the water socket and the plug of the pump assembly.

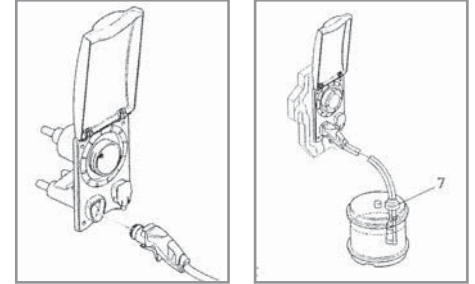

Plug the pump assembly into the socket.

Place the pump into the water container, ensuring that it is fully submerged before operating the system. The dust cover (7) is to stop contaminants falling into the water container.

To remove the pump assembly from the Ultraflow Filter Housing, pull the lower trigger and pull out the hose plug.

△ Do not remove by pulling the hose or electric cable.

ROUTINE MAINTENANCE

1. Ensure that the O-ring seal on the hose plug and socket are free from dirt.
2. To aid fitting of the plug assembly smear the O-ring with vegetable oil.
3. To change the filter, turn the filter cap anti-clockwise and pull out the filter.

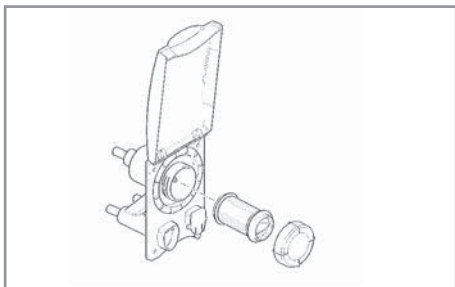

4. After installation, please drain off the first litres until the filtrate is clear.

Maximum filtering efficiency (cleaning effect) can only be achieved if the filter is changed at regular intervals. The filter must be changed within 35 days of initial use, even if it was not in use during this time. Please remember that water is foodstuff. We recommend that filtered water is consumed within 1 – 2 days and advise you to drain the system after long periods of disuse.

Use dial on the filter housing for guidance to replace after approx. 35 days of use.

NOTES

Never allow the pump to run dry. Always ensure that the pump is submerged in the water or the lifetime of the pump will be reduced.

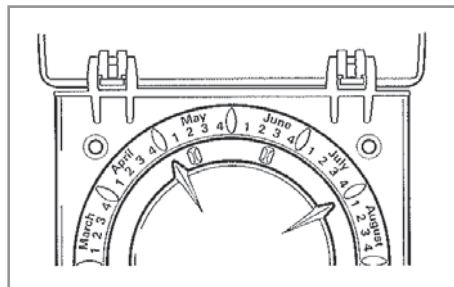

WINTERISATION

If there is any chance of the temperature falling below freezing when the caravan is not in use the water system and toilet system must be winterised. All the taps should be opened; the water filter and the caravan system drained using all the drain taps (cold/hot/waterheater) situated within the caravan. Additionally shower heads should be removed and the hose left hanging downwards.

During the winter when the caravan is not in use, it is advisable to remove the filter to avoid any retained water within the filter freezing.

If you use the Truma external shower (some models) you must drain the filter housing by connecting up the outside shower and allowing the remaining water to drain by the open shower head. The filter hole may be sealed with the filter cap.

Clean the water system at the start and end of each season.

FAILURE TO CARRY OUT THIS PROCEDURE MAY INVALIDATE YOUR WARRANTY ON ALL WATER SYSTEM ASSOCIATED PARTS.

STERILISING

1. When cleaning the water system at the start or the end of the season it is advisable to use a sterilising fluid e.g. Chempro SDP or similar. It is recommended that for this operation the filter is removed as the fluid reduces the effectiveness of a new filter.
2. Flush the system thoroughly to remove the effective fluid traces.
3. After sterilising the system at the start of the season it is recommended that a new filter cartridge should be fitted.

ULTRAFLOW WATER PUMP ASSEMBLY

The Water Pump Assembly comes complete with the water pump, container cover and storage clip. The submersible pump needs no priming and is extremely quiet in operation.

ULTRAFLOW SURGE DAMPER/PRESSURE SWITCH

The Ultraflow Surge Damper enables an even water flow in the pressurised water supply. The integrated electronically controlled pressure switch turns the water pump on and off regardless of the momentary atmospheric pressure and battery power (between 10v and 14v).

Together with the Ultraflow Surge Damper the caravans water supply operates as a pressurised system.

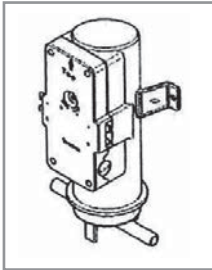

Please note that a correct function of the Truma pressure switch is only ensured with the genuine Ultraflow Pump Assembly.

ON LASER MODELS THE WATER CAN BE SUPPLIED FROM THE UNDERSLUNG WHALE TANK (SEE SEPARATE INSTRUCTIONS).

ULTRAFLOW OUTDOOR SHOWER

The outdoor shower connects directly to the Ultraflow Filter Housing beside the pump socket. The supplied connector with quick fittings ensures an easy installation.

Please note, that the shower has no electrical connections and works only in a pressurised system.

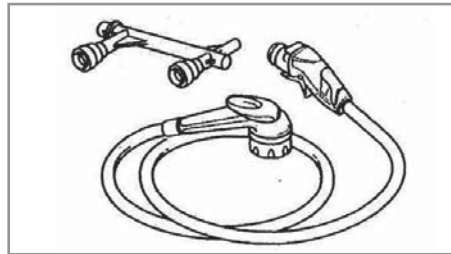

ULTRAFLOW WATERLINE

The Ultraflow Waterline is a 15 metre “food quality” hosepipe. It comes complete with fittings and a special pressure-reducing adaptor, which allows caravanners to connect their Ultraflow caravan water system direct to a mains water supply with modification.

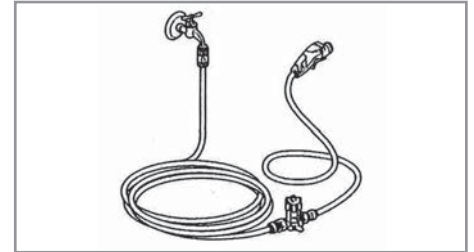

ULTRAFLOW REPLACEMENT FILTER

The Ultraflow Filter Cartridge is a high quality water filter, which removes unpleasant tastes and odours from the caravan’s stored water. For the occasional caravanner, the cartridge should be replaced at the start of each season. For the regular caravanner we recommend to replace the filter after 35 days of use.

MIXER TAPS

The shower, hand basin and kitchen taps are operated by raising or lowering the handle to control the flow and moving from side to side to blend hot and cold water to achieve the desired temperature.

OPERATION OF THE WATER SYSTEM

After the waste connections have been made, all the taps have been closed, the

CONNECTING SERVICES - WATER

water heater drain tap and the hot and cold drain taps closed. Check also that your external container is full, and the pump submerged.

1. Switch on the 12v master switch.
2. Turn on the pump at the switch panel.
3. The pump will run for a short time as it is priming the system.
4. Open a cold tap and leave open until there is a good flow of water.
5. Close that tap and carry out the same operation on the remaining cold taps.
6. Repeat this operation with the hot taps until there is a good flow. This will take longer as your Truma water heater will be filling.

WHALE ON BOARD SYSTEM (LASER)

The external/onboard water system fitted to the Laser range gives the user ultimate flexibility of water supply to the caravan. This includes a self-contained 38 litre underslung tank.

The system can be used in five modes.

1. Supply to the caravan from an external water container.

2. Supply to the caravan from a mains water supply.(By use of an Ultraflow Waterline)
3. Fill the underfloor tank from an external water container.
4. Fill the underfloor tank from a mains water supply.(By use of an Ultraflow Waterline)
5. Supply the caravan from the underfloor tank.

OPERATION OF THE UNDERFLOOR WATER TANK SYSTEM

As submersible pump system see Control Panel Instructions.

NOTE: The external pump will automatically switch off when the tank is full.

TANK DRAIN OPERATION

The water tank should be drained when the vehicle is not in use or is in transit.

Simply lift the drain plug handle out from recessed area, rotate 45° and rest on top surface as shown in the diagram. This will enable the tank to be drained without having to hold the handle. When the tank is drained, refit the handle by pushing through the drain plug, to seal the tank from debris.

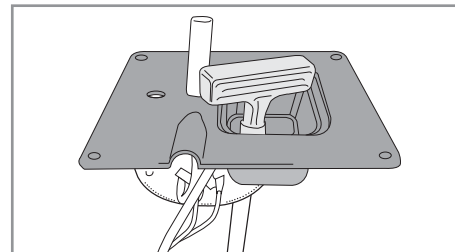

NOTE: The tank module is connected to the caravan water system and wiring. Please refer to the Ultraflow instructions.

IMPORTANT – Auto change over

The lower float switch within the tank, will automatically switch over to an external water supply, when the tank water level drops below the bottom float position.

MAINTENANCE

To clean and sterilise inside the water tank, use diluted sterilising fluid and fully flush tank with water afterwards. Ensure an industry recommended freshwater tank cleaner is used.

TROUBLESHOOTING

The Whale water tank is fitted with a control module, in the unlikely event you are experiencing problems with the system, please refer to the table opposite.

Problem	Possible Causes	Potential Solution
Pump fails to turn on	Loose wiring connection Pump circuit has no power. Blown fuse. Pressure switch failure Defective motor.	Remake a sound connection Replace fuse/reset Reset pressure switch using manufacturer's instructions. Replace pump.
Float switches fail to operate.	Loose wiring connection. Defective switch.	Remake a sound connection. Contact Whale Support.
Tank leaking from drain plug	Drain stem not engaged past O-ring.	Reseal ensuring the drain system is fully home.

If the problem persists contact Whale Support on +44 (0845 217 2933

WINTERISING

Freezing in winter may cause damage to the Whale under-floor tank and module. To avoid this damage, ensure the system is completely drained.

1. Drain the fresh water tank using the drain stem.
2. Turn pump on and open all taps (including drain valve) and allow the pump to purge the water from the system **(not suitable for submersible systems)**.

3. Open the taps until water flow stops **(suitable for submersible systems)**.
4. Turn off power isolator switch for water pump.
5. Remember to leave all outlets open.

FAILURE TO CARRY OUT THIS PROCEDURE MAY INVALIDATE YOUR WARRANTY ON ALL WATER SYSTEM ASSOCIATED PARTS.

TRAVELLING

Do not travel with water in the tank.

It is strongly recommended that all water is drained from the tank before travelling.

GAS (LPG)

The gas installation of your caravan has been designed to meet the requirement of EN1949 and BS 5482.

EN1949 requires a fixed outlet pressure regardless of the gas type and lays down a harmonised pressure of 30mbars for LPG installations in touring caravans across Europe. Your caravan is fitted with a regulator which meets these requirements and thus allows users to move freely between European countries by being able to purchase any LP gas type. Different bottle types are accommodated by using different hose adapters, which connect to the 30 mbar regulator.

It should be noted the standard UK domestic butane or propane regulator is not suitable for use on caravans manufactured to EN1949. They are not set on 30 mbar and have a greater outlet pressure tolerance. Likewise the current standard automatic changeover regulator will not be suitable.

WARNING

- Do not use appliances which have a different working pressure.
- The gas system should only be modified by competent and qualified persons.
- The gas system and appliances must be inspected/maintained every 12 months (irrespective of usage) by a qualified technician.
- The caravan is designed to accept a maximum of 2 x 7 kg steel butane or 2 x 6 kg propane bottles or 1 x 5 kg and 1 x 10 kg BP light cylinders.
- Ensure there is no stress at the hose assembly when it is connected to the cylinder.

- Inspect flexible hoses on a regular basis for deterioration, wear and damage and renew as necessary with an approved type, in any case no later than the expiry date marked on the hose.
- Do not site bottles outside the gas locker compartment as this would necessitate the use of a high pressure hose in excess of 450mm.
- Do not use any additional independent gas appliances inside your caravan.
- When changing cylinders ensure that all appliances are turned off and the service valve is closed.
- Use appliances only for the purpose for which they were designed/installed eg. Do not use cookers as heater

TYPES OF GAS:

BUTANE

Butane is supplied in the U.K. in Green or Blue bottles.

All these have a male left hand thread except for Camping Gaz, which has a special female right hand, Calor, 7.5 kg and 15 kg bottles have a special clip-on connection.

Continental bottles usually have a male left hand thread similar, but not identical, to U.K. Butane.

Butane is suitable for use at temperatures down to 2°C but will not work below that.

PROPANE

Propane is supplied in red steel containers or partly red bottles which have a female left hand threaded connector or by BP Gas Light in green cylinders.

Scandinavian countries use the same connector.

Germany or Austria supply Propane with a male connection.

Propane will work at temperatures as low as - 40°C and is therefore suitable for all winter caravanning.

CONNECTION

Make sure that heating, cooking appliances and gas cylinders are switched off.

Ensure the regulator has been connected via the flexible hose supplied by your dealer to the gas bottle.

Note: Gas bottle valves should always be in the 'OFF' position when towing.

HOSES

Your caravan will be supplied with a Truma High Pressure hoses which must be used between the pressure regulator and your gas bottle (there are different adapters for Propane and Butane and different types of cylinders).

Ensure that the open end of the gas hose is protected against the entry of dirt or insects if it is to be left disconnected for any extended period.

WARNING

Inspect flexible hoses regularly for deterioration, wear and damage, and renew as necessary with an approved type, in any case not later than the expiry date marked on the hose.

GAS SAFETY ADVICE

Regularly check flexible gas hose. Finally make sure that each gas appliance is working efficiently to the recommendations of the appliance manufacturers.

Awning Spaces LPG Appliance Exhaust

There is no danger of pollution of an enclosed awning space from the LPG exhaust from a refrigerator venting into it.

If totally enclosed, water heaters may produce sufficient exhaust to pollute the awning space, from a general comfort, smell and hygiene point of view. In extreme cases there could be a build up of carbon dioxide to a dangerous level.

Caravan owners are advised to allow some fresh air circulation in the awning space when such appliances are in use.

VENTILATION

Fresh air circulation should be allowed below the caravan when appliances are in

use. At least three sides of the underfloor space should always be kept open and unobstructed especially by snow. Do not make any additional openings in the floor.

WARNING

Under no circumstances should fixed ventilation openings or gas appliance flues be obstructed in any manner as this could lead to a build up of dangerous carbon monoxide. Gas drop holes under appliances should also be kept clear at all times.

Grilles and flues should be kept clean and free from dust.

Fixed ventilation/gas drop holes are sited under gas appliances in various locations in your tourer.

GAS LEAK PRECAUTIONS

- a) NO SMOKING, extinguish all naked flames.
- b) If a gas leak is suspected immediately turn off all supply at the cylinder.
- c) NEVER look for a leak with a naked flame. Always use a soap solution or special leak detecting liquid when testing connections.
- d) DO NOT operate any electrical apparatus, especially light switches. If the leak is not

CONNECTING SERVICES - GAS

obvious, the caravan should be evacuated and qualified personnel consulted. Turn the supply off at the cylinder.

- e) Avoid naked flames when connecting or changing a cylinder.

FACTS ABOUT LPG

LPG has been given a smell by the manufacturers in order to identify leaks.

The gas is heavier than air and therefore sinks to the lowest point.

WARNING:

Never allow modification of electrical or LPG systems and appliances except by qualified persons.

Aerosols and highly flammable liquids must not be stored in the compartment behind, or adjacent to, any gas appliance.

Some industrial LPG appliances operate a high pressure and require a 'high pressure' regulator. This often has an adjusting handle on it. NEVER use such a regulator on a caravan.

FLUE INSTALLATIONS

All flue installations should be inspected once a year throughout their length for corrosion. Flues should be replaced if any

sign of perforation is found. Ensure that the replacement is of an approved type.

Gas Equipment Isolation Manifold

This is located in one of the lower cupboards and the circuits covered by each tap are clearly indicated. If a fault is suspected then isolate the unit involved and consult your Dealer.

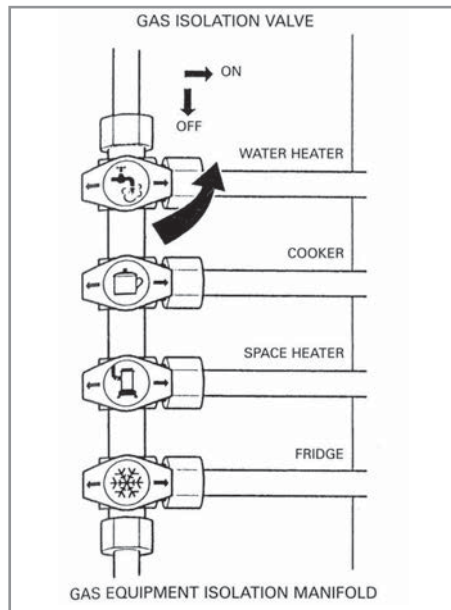

External Quick Release Gas Coupling (BBQ Point)

This is supplied with a nozzle for your appliance which is a simple push-fit into the coupling on the caravan.

To attach, push back the knurled collar on the coupling. This action automatically seals the gas supply and will then allow you to turn on the gas supply.

WARNING:

Do not use a gas barbecue in an enclosed awning space.

CHANGING GAS CYLINDERS

If a gas cylinder is to be left disconnected for an extended period, then care must be taken to ensure that dirt and insects cannot enter the open end of the gas supply hose.

CONNECTING SERVICES - GAS

Empty cylinder:

- i. Turn off cylinder valve and all gas appliances
- ii. Release retaining strap.
- iii. Remove hose connection from cylinder.
- iv. Remove cylinder from gas locker and stand on ground.

Full cylinders

- i. Remove plastic protector from cylinder.
- ii. Place cylinder in gas locker.
- iii. Connect hose to cylinder (If you are changing the type of cylinder you will have to change this hose or use an adapter – See your Dealer). Avoid tension on the rubber gas hose.
- iv. Connect retaining strap.
- v. Turn on cylinder valve and then systematically turn on appliance valves relight appliances as required.

ELECTRICITY

MAINS SUPPLY (LOW VOLTAGE)

WARNING

Never allow modification of electrical or LPG systems and appliances except by qualified persons

Your caravan's main electrical installation is designed to run on a 230v 50hz a.c. supply.

On Arrival At Caravan Site

1. Before connecting the caravan installation to the mains supply, check that:
 - (a) the mains supply is suitable for your installation and appliances, i.e. whether it is a.c. or d.c. and whether it is at the correct voltage and frequency.
 - (b) your installation will be properly earthed. Never accept a supply from a socket outlet or plug having only two pins, or from a lighting outlet.
 - (c) any residual current device (earth leakage circuit breaker) in the mains supply to the caravan has been tested within the last month.

In case of doubt, consult the site owner or his agent.

2. **MAKE SURE THAT THE SWITCH AT THE SITE SUPPLY POINT IS OFF AND THAT ALL ELECTRICAL EQUIPMENT IN THE CARAVAN IS SWITCHED OFF.**

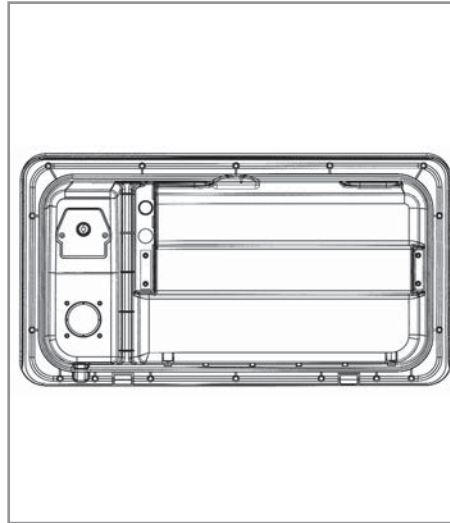

3. Remove any cover from the electricity inlet provided on the caravan and insert the connector of the supply flexible cable.
4. Remove any cover from the socket outlet provided at the site supply point, and connect the plug at the other end of the supply flexible cable to this. Switch on the main switch at the site supply point.

Note: If you wish to use any 12v appliances, you must turn on at the control panel.

IN CASE OF DIFFICULTY CONSULT AN APPROVED ELECTRICAL INSTALLATION CONTRACTOR (WHO MAY BE THE LOCAL ELECTRICITY BOARD). IT IS DANGEROUS TO ATTEMPT MODIFICATIONS AND ADDITIONS YOURSELF.

LAMPHOLDER-PLUGS (BAYONET-CAP ADAPTORS) SHOULD NOT IN ANY CIRCUMSTANCES BE USED.

On Leaving Caravan Site

5. Reverse the procedure described in Paragraph 3 and 4 above.

IT IS IMPORTANT THAT THE MAIN SWITCH AT THE SITE SUPPLY POINT SHOULD BE SWITCHED OFF, THE SUPPLY FLEXIBLE CABLE DISCONNECTED, AND ANY COVER REPLACED ON THE SOCKET OUT LET AT THE SITE SUPPLY POINT. IT IS DANGEROUS TO LEAVE THE SUPPLY SOCKET OR SUPPLY FLEXIBLE CABLE LIVE.

Periodically

6. Preferably not less than once a year, the caravan electrical installation should be inspected and tested and a report on its condition obtained as prescribed in the Regulations for Electrical Installations, published by the Institute of Electrical Engineers.

Note: Connection to a mains voltage supply OVERSEAS requires particular attention.

Care must be taken when connecting supplies abroad since the supplies can be REVERSE POLARITY.

The significance of REVERSE POLARITY is that when equipment is switched off it may not be electrically isolated.

The only certain way of making equipment safe is to unplug it.

A means of checking the polarity of the mains supply when overseas is useful.

There are available several proprietary makes of equipment for the purpose.

If it can be achieved, it is preferable to connect live to live, and neutral to neutral to maintain full electrical protection.

CHECK all caravan equipment is set-up to accept the site supply before actually switching on.

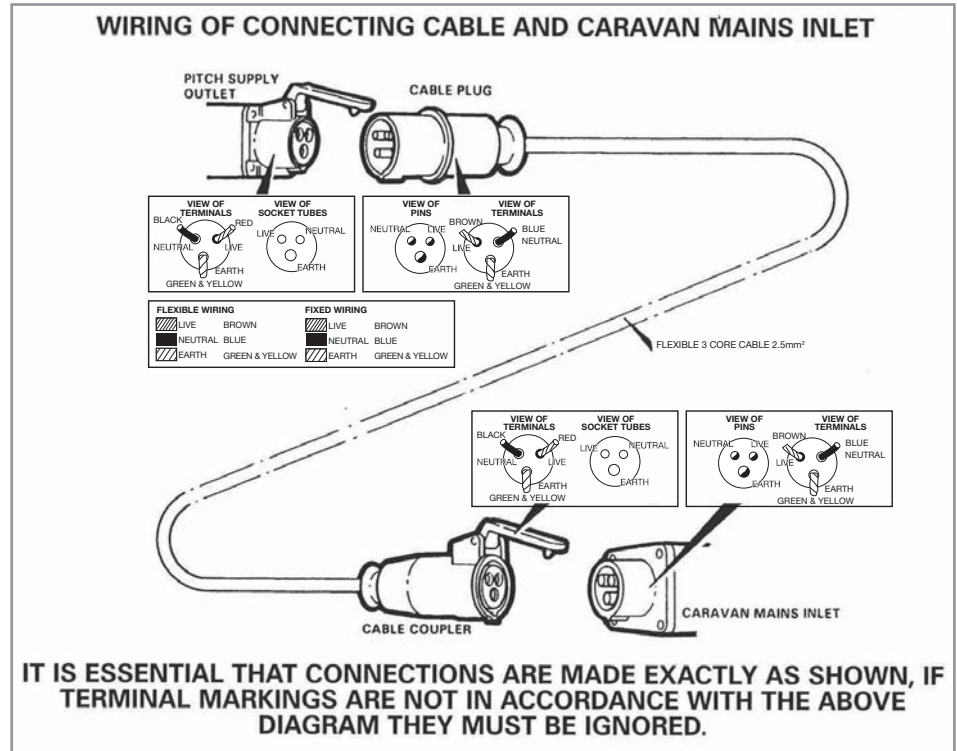

Note: It is possible that all of the 230V mains electrical equipment may not be able to be operated simultaneously. A typical UK caravan site mains hook up point provides a maximum output of 16 amps and on some continental sites the

available output may be as low as 5 amps. If your loading exceeds the site supply it may trip the site circuit breaker. Please check the available mains output with your site operator.

CONNECTING SERVICES - ELECTRICITY

The following items need to be added together if used simultaneously.

230V Mains equipment typical consumption figures:

Fridge		0.80 amps
Charger		0.80 amps
Water heater		3.7 amps
Blown air heaters (Elec)		8.00 amps
Colour TV		2.50 amps
Microwave		6.00 amps
Air conditioning (Elec)		4.00 amps
Kettle	1.5 kw	6.5 amps
	3.0 kw	13.0 amps

12V ELECTRICAL SYSTEM (EXTRA LOW VOLTAGE)

Your caravan is fitted with a Power Distribution Unit (PDU). This comprises of the 230 volt RCD and MCB's, Relay housing and Power Supply/Battery charger, this is located under the front off side seat towards the centre of the caravan.

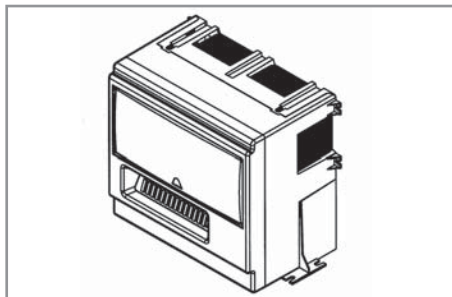

RCD & MCB'S

This is for the 230 volt distribution RCD (Residual Current Device) and MCB's (Miniature Circuit Breakers). The RCD gives protection against electric shock, in the event of an earth fault that would cause earth leakage or earth directly through the human body the RCD will automatically disconnect the whole 230 volt supply. Only after removing the fault will the RCD be able to be switched back to the ON position. This is done by moving the switch upwards against the spring pressure and so restoring the supply.

The MCB's are designed to protect both for the overload of each circuit and also the short circuit. In both events the MCB will automatically switch to the OFF position and when the fault is removed they can be switched upwards against the spring to the ON position. Both the RCD and MCB's will

only latch back into position if the fault has been removed. If these devices will not locate back into the ON position consult a qualified electrician.

N.B. The information provided in the guide relating to fitted equipment is only intended as a quick reference. Comprehensive details of maintenance and fault finding charts where appropriate can be found by referring to the accompanying manufacturer's literature. If any doubts still exist about the operation of the equipment qualified personnel or your caravan dealer should be consulted.

WARNING:

Always disconnect the electrical connector between the towing vehicle and the caravan before connecting a mains supply to the caravan and before charging the caravan battery by any other means.

BATTERY CHARGER/POWER SUPPLY

AMARA ONLY

This caravan is fitted with a 20 amp 12 volt power supply providing the extra low voltages to the caravan and charging the battery. It will give a constant 13.8 volts that will supply the caravan when it is needed, as long as the 230 volt supply is connected. When you disconnect 230 volt supply the caravan auxiliary battery will supply your caravan extra low voltage system.

LASER/PASTICHE AND VIP

These caravans are fitted with a dual stage battery charger and a power supply to meet your caravan 12 volt requirements.

When the 230 volt supply is connected the battery charger will charge your auxiliary battery at 13.8 volts constantly and for 4 hours in a 24 hour period will boost this to 14.2 volts to ensure your battery is kept in prime condition. At no time during this period will any power for the 12 volt system in your caravan use the battery. At the same time the power supply side of the unit will supply your caravan requirements at 13 volts up to 20 amps.

When the 230 volt supply is disconnected for any reason the power supply will automatically switch the auxiliary battery

into the 12 volt system and feed your requirements.

NOTE: WE RECOMMEND A BATTERY TO BE USED AT ALL TIMES.

The Thetford Refrigerator requires that the battery is connected for the gas igniter to work.

CAUTION!

- As with all types of transformer/power supply a certain amount of heat is generated, this will vary with the charge rate, therefore adequate space and ventilation must be provided and maintained around the unit to aid cooling.
- Keep all flammable materials and aerosols well away from this appliance and other sources of heat, as this could cause the pressure in the aerosol to rise. Should a seal then fail it is possible an explosion will ensue.
- **N.B.** Remember any work, replacing parts or repair, **must only** be carried out when the mains supply has been disconnected, and only by a qualified electrician.

RELAY HOUSING

Provides the 12 volt distribution through out the caravan. All the fuses are located at the front of the PDU behind the lift up cover. Ensure fuses being replaced are of the rating

indicated on the PDU and never increase the rating of the fuse you replace.

The system is fully compliant with the EMC recommendations within the EU.

When the caravan is plugged into the car the 12 volts system will be supplied by the car except the refrigerator...

When the car ignition is switched on and the car is started the system will automatically switch the 12 volt supply in the caravan off, then it will connect the refrigerator 12 volts on and connect the auxiliary battery to charge from the car.

The car alternator, in this mode, will only supply the battery with a small trickle charge.

CONNECTING SERVICES - ELECTRICITY

TESTING RCD

Periodically it is necessary to test the operation of the RCD. This is achieved by ensuring that it is switched in the ON position with an electricity supply connected and by pressing the test button marked 'T'. The unit should immediately switch to the OFF position. Provided this happens all is correct and the switch should be returned to the ON position, upwards against the spring pressure, to restore the supply back to

CONNECTING SERVICES - ELECTRICITY

normal. The RCD also acts as the main switch for the unit and if it is required to switch off all circuits in the caravan this can be achieved by switching the RCD to OFF.

REVERSE POLARITY

When connecting mains supply abroad, the supply can be of reverse polarity. The significance of this is that when equipment is switched OFF it may not be electrically isolated. The only certain way of making sure equipment is safe is to unplug it.

There are several; proprietary makes of equipment to check the polarity of mains supply. This equipment is useful, mostly for mains connection when overseas.

If reverse polarity occurs on site then reverse the live and neutral connections inside the plug on your mains cable. This must be done by a qualified electrician. Ensure that the cable is re-connected to its original configuration on return to the UK.

If it can be achieved, it is preferable to connect live to live, and neutral to neutral to maintain full electrical protection.

BATTERY BOX

Located in the battery box below the mains inlet your caravan will be fitted with an aerial and satellite connection if an external source is available.

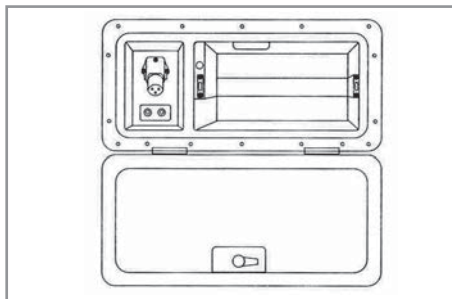

ALWAYS USE BATTERY TRAY PROVIDED.

WHEN USING A BATTERY WITH A VENT KIT, LEAVE THE VENT TUBE IN THE BATTERY TRAY. VENTILATION IS PROVIDED THROUGH THE BATTERY BOX DOOR WHEN THE DOOR IS CLOSED AT THE TOP AND BOTTOM.

WARNING

Do not smoke – explosive gases may be present at the battery. Prevent flames and sparks in that area. Switch off all appliances and lamps before disconnecting the auxiliary battery.

WARNING

Batteries should be tested regularly to ensure reliability and safety. Should a fault develop the charger will continue to try to charge the battery leading to possible overheating and failure.

If in doubt have it checked by your supplier.

Battery Type

It is recommended that a top quality 12V leisure battery of a sealed type is used which is essential to flatten out current surges. It should be noted that a leisure battery is designed to deliver a lesser current over longer periods which is often referred to as ‘Cycling’, or ‘Deep cycling’. Leisure batteries are constructed differently to starter batteries to withstand the many cycles of discharging and recharging. The battery locker will take up to a 120 amp hour battery (depending on the manufacturer) and we would recommend you use a high quality 110 amp hour minimum. It should be noted that if using a motor mover the battery should be of an AGM type and capable of at least a 500 amp cold crank current. That is the power the battery can deliver for a given time under certain conditions and is usually referred to as its CCA (cold cranking amps).

There are various different methods of measuring the CCA, but the most popular standard in the UK is the SAE (Society of Automobile Engineers) method. Always use the battery tray and retaining strap when installing a battery always ensuring fixing across to two points never around the battery.

Never leave a leisure battery in a discharged (flat) condition as this will cause the battery plates to 'Sulphate' rendering the battery useless and also invalidate any warranty. Lead-acid batteries must be left in fully charge condition, ideally disconnected when left idle for long periods and a top-up charge performed periodically. These rules apply to all types of lead-acid batteries.

CAUTION: Take care not to expose the battery to sparks or naked flames, as explosive gases may be present

N.B. As with mains supply, switch off **all** appliances and lights before disconnecting the battery.

Generators

When using a generator ensure that the actual output voltage does not exceed the

rated generator output voltage, and the rated input voltage of the consumer unit, otherwise internal damage to the unit could occur.

Before starting the generator ensure that the RCD lever is in the off position.

N.B. Refer to the manufacturer's instruction book before use.

N.B. It is important as with all power supplies that the generator is run up to speed and allowed to settle before switching it onto the system.

Light Switches – Pastiche/VIP/Laser

The front side high level lights in Pastiche/VIP/Laser are fitted with a dimmer light switch. To operate these just press and release for the on/off function and hold to go through the dimmer cycle.

Control Panel Amara



- Pump ON/OFF Switch/Pump Run Indication
- Master 12 volt ON/Off Switch
- 12 volt Lighting Switch
- Voltmeter Switch
- Awning Light Switch

When the caravan is connected to the car, the car supply is connected automatically. For your convenience the master 12 volt switch, switches all the 12 volt circuits from the caravan except for the circuits requiring dedicated supplies from the battery, such as fridge ignition or alarm if fitted.

The pump switch, switches the supply to the pump, but the pump run light will only illuminate when water is being used.

DIGITAL CONTROL PANEL (PASTICHE/VIP/LASER)

Overview

The BCA-DCP-1200 is the central control unit for your caravan. It allows you to easily control the electrical system, saving you power and providing more useful functionality.

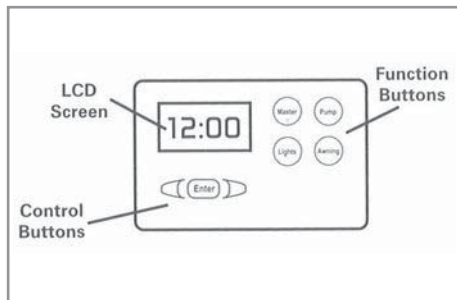

- The LCD screen provides clear feedback to display large menus and information.
- The control buttons offer an easy way to select menus and adjust user settings.
- The function buttons give quick access to regularly used tasks.

MAIN FUNCTION BUTTONS

Master Switch

Pressing the Master Switch will switch power to all unessential accessories in your caravan. The alarm, radio, awning light and fridge will still receive power when the master is off.

Lights Switch

Pressing the Lights Switch will switch power to all the lights circuits in the caravan. If the master switch is off then this button will not function.

Pump Switch

Pressing the Pump Switch will switch power to the water pump. If the master switch is off then this button will not function. If the water pump is running a warning icon **P** will appear in the clock menu.

Awning Switch

Pressing the Awning switch will switch power to the awning light. The awning light works independently from the master switch.

Menu Details

 The available menus are controlled by the 3 control buttons. The left and right buttons cycle through the available menus. Pressing the enter button accesses

any extra options that the current menu holds. Only menus relevant to your caravan will be displayed.

Clock



The clock menu is the default menu. If the control panel is inactive the screen will automatically revert here before going on standby.

Setting the clock



1. If the back light is off, bring the device out of standby by pressing the enter button.



2. On the clock menu, hold Enter  for 3 seconds until the house begin to flash.

3. Press  Left and  Right until the desired hour is reached.



4. Press Enter.  The minutes will begin to flash.



5. Use  Left and  Right until the desired minute is reached.

6. Press Enter  to set time, seconds will automatically be reset to 00.

Battery Voltage

 The Battery Voltage menu displays the voltage of the leisure battery.





An estimate of your batteries remaining charge can be seen by pressing Enter  on this menu and selecting the % unit.  Based on standard battery voltages, if your battery measures over 12.7v it is 100% charged. Below 12v is 0% charged.

You can return to displaying in volts by pressing Enter  and selecting the V unit. 

 If your battery voltage drops below 12.2v (25%) a warning icon will display on the clock menu.

The battery voltage may read much higher than normal if it is recharging.

Temperature

 The temperature inside your living space can be viewed using the Internal Temperature menu. You can change between degrees Celsius and Degrees Fahrenheit by pressing enter  and selecting Left  for °C or Right  for °F.

CARAVAN EQUIPMENT



Water Tank Level

If you caravan is fitted with a water probe, then the water level within the tank is displayed on the Water Tank Level menu. The percentage of water remaining in your tank is displayed on the screen.

 If your water tank gets below 25%, the low water warning icon will display on the clock menu.

Warning Icons

There are a number of warning icons that display above the time on the clock menu if certain undesirable situations occur. Here is a summary of what they mean.

Icon	Description
	The water pump is currently running
	The leisure battery voltage is below 12.2v
	The water tank is below 25% full

Dimmer Switches

Your caravan may be fitted with dimmer lights that are controlled via switches mounted on the walls of your living space. Quickly pressing these switches will turn the lights on and off. When the light is on, you can hold the button down to slowly dim the brightness. When a desired brightness is reached, release the button and the level will be saved. Holding the dimmer button again will cause the lights to increase in brightness until full power is reached.

Warranty

If you believe there is a problem with your control panel please contact your caravan dealer who will be able to help.

Your caravan will be fitted with a Truma Combi (Amara/Pastiche/VIP) water heater. The Laser is fitted with the Alde Combined System.

TRUMA COMBI

Amara, Pastiche and VIP caravans are fitted with the Truma Combi this is a warm air heater with integrated hot water boiler.

The primary power source is gas with a secondary source of 230 V electric. For room heating the combi can work on dual fuel.

The burner operates fan-supported, which ensures trouble-free function. The unit also has heating elements for elements for electrical operation. The unit is unsuitable for use as an instantaneous water heater.

In **winter operation** the heater can be used to heat the room and simultaneously warm water. If only warm water is required, select **summer operation**.

3 different energy selections are available for operating the unit.

- **gas operation only**
Propane/Butane for autonomous use
- **electrical operation only**
230 v for use on camp site
- or gas and electrical operation – **mixed operation** only possible in winter mode

Winter Operation

In winter operation, the unit automatically selects the required power setting according

to the temperature difference between the temperature set on the control panel and the current room temperature. When the boiler is filled, the water is automatically heated as well. The water temperature depends on the selected operational mode and the heater output.

All 3 energy selection options can be used for winter deployment but if the ambient temperature is below 6 C mixed operation or gas only is recommended.

With gas operation the unit automatically selects the output level that is required.

For **electrical operation** depending on the fuse protection at the camping site, power of 900 W (3.9 A) or 1800 (7.8 A) can be manually selected.

Note: If more output is required (e.g. heating up or low outside temperatures) gas or mixed operation should be selected so that enough heating power is always available.

With mixed energy operation selected, the 230 V electric supply is prioritised over the gas operation if the heat requirements are low (i.e. to maintain the room temperature). The gas burner is only in operation when there is a greater requirement for heat. The gas burner is also switched off first during the heating operation when heat requirements reduce.

Summer Operation

(Boiler operation only)

Gas operation or 230 V electrical is used for hot water preparation. The water temperature can be set to 40 C or 60 C.

With **gas operation** the water is heated at the lowest burner setting. Once the water temperature is reached, the burner switches off.

Depending on the fuse protection at the camping site, power of 900 W (3.9 A or 1800 W (7.8A) can be manually selected for **electrical operation**.



Mixed operation is not possible. With this setting the unit automatically selects electrical operation. The gas burner is not enabled.

Airflow

The position of the new heating system fitted to the Amara, Pastiche and VIP ranges requires that the airflow be balanced by the operator to get the desired heating distribution.

The reason for this is simple, in that the airflow will try to travel down the path of least resistance to the vents adjacent to the unit at the front of the caravan, resulting in a reduced flow to the rear.

This airflow can be easily balanced by using the butterflies in the blown air outlets to optimise the flow to different parts of the caravan.

Hot water and Showering

Unlike the Truma Ultrastore you will not achieve the best out of your combi by putting the hot water on and leaving it on.

To obtain the best out of your combi you will need to do a small degree of planning and choose one of the following options

Option 1 – Timer

If you like to shower in the morning or the evening you can set the timer to deliver hot water when you really want it.

In winter mode and with water temperature set to 60° set the timer for approximately 1 hour before showering.

Option 2 – Manual control

Hot water is set to 40° as standard then approximately 10 – 15 minutes before showering you should switch to 60° for a power boost.

Reheat for a follow on second shower

The quickest water reheat times can be gained by having the water set to 60° temperature and showering approximately 10 minutes after the temperature setting

stops flashing on the LCD control panel.

Safety Instructions

The use of upright gas cylinders from which gas is **taken in the gas phase** is mandatory for the operation of gas regulators, gas equipment and gas systems. Gas cylinders from which gas is taken in the liquid phase (e.g. for fork lifts) must not be used, since they would result in damage to the gas system.

If the gas system is leaking or if there is a smell of gas:

- extinguish all open flames
- open windows and door
- close all quick-acting valves and gas cylinders
- do not smoke
- do not activate any electric switches
- ask an expert to inspect the entire system.

 Repairs may only be carried out by an expert!

Guarantee claims, warranty claims and acceptance of liability will be ruled out in the event of the following:

- modifications to the unit (including accessories).

- modifications to the exhaust duct and the cowl.
- failure to use original Truma parts as replacement parts and accessories.
- failure to follow the installation and operating instructions,

It also becomes illegal to use the appliance, and in some countries this even makes it illegal to use the vehicle.

The gas supply's operating pressure (30 mbar) must be the same as the unit's operating pressure (see type plate).

Liquid gas systems must comply with the technical and administrative regulations of the respective country of use (e.g. EN 1949 for vehicles in Europe). The national legislation and regulations (e.g. DVGW Work Sheet G 607 for vehicles in Germany) must be observed.

In Germany, the gas system must be retested every 2 years by a liquid gas specialist (DVFG, TÜV, DEKRA). The test must be confirmed on the respective test certificate (G 607).

The vehicle owner is always responsible for arranging the inspection.

Liquid gas equipment may not be used when refuelling, in multi-storey car parks, in garages, or on ferries.

CARAVAN EQUIPMENT

During the initial operation of a brand new appliance (or after it has not been used for some time), a slight amount of fumes and smell may be noticed for a short while. It is a good idea to heat the device up several times in summer operation (60°C) and to make sure that the area is well ventilated.

Heat sensitive objects such as spray cans or flammable liquids may not be stored in the same compartment where the heater is installed because, under certain conditions, this area may be subject to elevated temperatures.

Only pressure regulating equipment that complies with EN12864 (in vehicles) with fixed output pressure of 30 mbar may be used for the gas system. The flow rate of the pressure control device must correspond to at least the maximum consumption of all devices installed by the system manufacturer.

We recommend the gas pressure control systems Truma SecuMotion/MonoControl CS for vehicles and the gas pressure control systems Truma DuoComfort/DuoControl CS for dual-cylinder gas systems.

At temperatures of around 0°C or less the gas pressure regulator and the changeover valve should be operated using the EisEx regulator heater.

Controller connecting hoses that meet national regulations must always be used in the respective country for which the equipment is destined. These hoses must be checked regularly for brittleness. Winter-proof special hoses must always be used if the equipment is operated during the winter.

Pressure regulating equipment and hoses must be replaced with new ones no more than 10 years after the date of manufacture (every 8 years if used commercially). This is the responsibility of the operator.

Important operating notes

The integrity and tight fit of the exhaust gas double duct must be checked regularly, particularly at the end of long trips. Also check the mounting of the appliance and the cowl.

Following a blow-back (misfire) always have the exhaust gas system checked by an expert

Always keep the cowl for the exhaust duct and combustion air intake free of contamination (slush, ice, leaves etc.).

The hot air outlets and the recirculated air intake opening must be free so that the unit does not overheat. The integrated temperature limiter blocks the gas supply when the unit becomes too hot.

Operating Instructions

Always observe the operating instructions and “Important operating notes” prior to starting! The vehicle owner is responsible for the correct operation of the appliance.

The installer or vehicle owner must apply the yellow sticker with the warning information, which is enclosed with the appliance, to a place in the vehicle where it is clearly visible to all users ((e.g. on the wardrobe door)! Ask Truma to send you stickers, if necessary.

Directive 2004/78/EC stipulates that a safety shut-off device is required if caravans are being heated while driving.

The Truma gas pressure control systems SecuMotion/MonoControl CS satisfy these requirements.

 Before using for the first time, it is essential to flush the entire water supply system through with clean water. If the heater is not being used, always drain the water contents if there is a risk of frost. **There shall be no claims under guarantee for damage caused by frost!**

Materials in the device which come into contact with water are suitable for use with drinking water (see manufacturer declaration www.truma.com – Downloads – Manufacturer Declaration).

CONTROL PANEL

Operating Instructions

Symbols used

 Symbol indicates a possible hazard.

 Comment including information and tips.

Safety Instructions

To protect you from electrical shocks, injury or burns the following basic safety principle must be observed when using electrical devices. Please read and follow these instructions before using the device.

Installation

Ensure that the devices are positioned safely and cannot fall down or over. Always position the cables to ensure they do not pose a tripping hazard. Do not expose electrical devices to rain. Do not operate electrical devices in damp or wet environments. Do not operate electrical devices close to flammable liquids or gases. Position the devices so that they are out of the reach of children.

Protection against an electrical shock

Only operate devices whose casings and cables are undamaged. Ensure the cables are installed safely. Do not pull on the cables

Use

Do not use electrical devices for purposes other than those stated by the manufacturer.

Repairs

Do not repair or modify the device. Please contact your dealer or the Truma Service (see service manual of www.truma.com).

Accessories

Only use accessories and additional devices that are supplied or recommended by the manufacturer.

Intended Use

The CP 25-UK is digital operating/display and control unit for the Combi 4 E/6 E. The device is designed to be installed in caravans and motorcaravans.

Initial operation or activation after a power cut

After the operating voltage has been connected, the unit will beep and the display remains dark. To switch on, press the

 key and the main screen will appear.

Function description

Main Screen

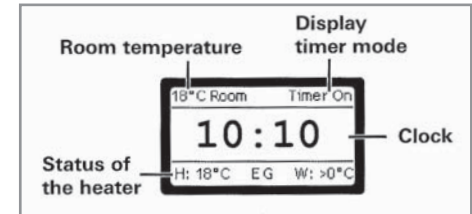

Room temperature: Display on when the heater is active

Timer: Display on when the timer is active

Clock: Only if the clock has been set, otherwise the Truma logo will appear in the display

Status of Heater

H: Set room temperature (e.g. 18°C)

EG: Energy selection (E = Electro, G = Gas)

W: Set water temperature

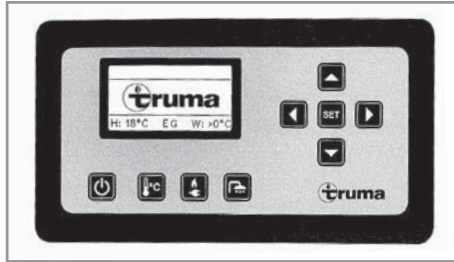

- Selection key upwards to select functions or set valves.
- Selection key downwards to select functions or set valves.
- Selection key backwards to select valves.
- Selection key forwards to select valves.
- On/Off.
 - Display and heater is switched on and/or off.
 - The clock is shown when the time is set.
 - After an interruption in the operating voltage, the display and the heater are switched off. If the time is shown, this needs to be set.

- Green LED shines when the heater is on
- Green LED flashes when the heater is after-running

Red LED shines when there is a malfunction

Manual Mode

- In manual mode, the heater is controlled via the 4 keys below the display.
- It is not necessary to set the time because the Truma logo is shown in the display instead of the time.

- A pre-selection between summer/winter operation must be made via the set up.

Room Temperature

When the menu is selected the yellow LED shines.

The current set room temperature is displayed and can be changed.

Key increases the room temperature (max 30°C) by 1°C.

Key reduces the room temperature (min 5°C) by 1°C.

A change in the room temperature needs to be confirmed with

Energy Selection

When the menu is selected the yellow LED shines.

Depends on summer/winter operation (see setup).

- Use key or to select the energy source and confirm with
- Bar shows current mode.

Summer operation

230 V – 4 A (electro mode 230 V, 900 W)

230 V – 8 A (electro mode 230 V, 1800 W)

Gas powered

Winter operation

230 V – 4 A (electro mode 230 V, 900 W)

230 V – 8 A (electro mode 230 V, 1800 W)

Gas powered

230 V – 4 A and gas (mixed operation gas and electro mode 900 W)

230 V – 8 A and gas (mixed operation gas and electro mode 1800 W)

- If the electro or mixed operations are selected and there is no 230 V power supply, the heating will not function.

Water temperature

When the menu is selected the yellow LED shines.

During the heating-up phase, the set water temperature flashes in the main screen.

- Use key  or  to select the water temperature and confirm with 

- Bar shows current mode

Depends on summer/winter operation (see setup).

Summer operation

Water 40°C

Water 60°C

Winter operation

Water > 0°C (heating **without** controlled water temperature, heating has priority), frost protection for the boiler.

Water 60°C

Timer Mode

- The heater runs in timer mode as soon as one or both timers have been activated in the setup.
- “Timer On” appears in the main screen.
- The heater is only active in the set time window (active timer).
- Only the energy selection can be changed in the case of an active timer.
- A change in the room or water temperature will automatically switch the control system into manual mode.

 Setup

In the main screen display you can enter the setup menu via the setup key.

The following settings can be made.

Back (return to main screen)

Timer 1 on/off (select  on/off)

Timer 2 on/off (select  on/off)

Summer/Winter (select  summer/winter)

Set clock

Set timer 1

Back (Return to main screen)

Start (Set start time)

Stop (Set stop time)

Water (Set water temperature)

Temp (Set room temperature)

The timer settings can be made every day until the timer is switched off.

If the room or water temperature is changed outside the timer menu, the timer is automatically switched off.

Set timer 2

Back (Return to main screen)

Start (Set start time)

Stop (Set stop time)

Water (Set water temperature)

Temp (Set room temperature)

The timer settings can be made every day until the timer is switched off.

If the room or water temperature is changed outside the timer menu, the timer is automatically switched off.

Buzzer on/off (select  on/off)

Backlight (brightness levels 0 – 9)

 If no action is taken, the display switches back to the main screen after a few seconds. The lighting switches off after a short delay.

Further information

See operating instructions Combi 4 E/Combi 6 E

Maintenance

Clean the panel with a dry and fluff-free cloth.

Disposal

The device must be disposed of in line with the administrative regulations of the respective country in which it is used. National regulations and laws (in Germany, for example, the End-of-life Vehicle Regulation) must be observed.



CARAVAN EQUIPMENT

ALDE CENTRAL HEATING AND HOT WATER SYSTEM - LASER.

Full instructions on the use of this system are included in the information pack you received with your caravan and we would strongly recommend you read them thoroughly before using the boiler.

The central panel for the system is situated by the door of the caravan and the following is a quick start guide.

Quick Start Guide

Use the Left  and right  arrow keys to move across symbols. Highlight the required symbol so that it flashes. You can then adjust that function.

Use the +/On and -/Off keys to adjust settings and turn functions On and Off.

On With 'On' displayed the boiler is in standby mode and ready to be given commands.

Off With 'Off' displayed the boiler is shutdown.

 Select your desired room temperature to call for heating. **Turn down when only hot water is required.**

30 min hot water booster, with this function 'On' the circulation pump for the heating is turned off. Used for additional hot water.

 Select 'On to operate the boiler LPG. **Note you can use gas and 230v electric at the same time if you wish.**

Select 1, 2 or 3kW to operate the boiler — on 230V Electric. (This depends on the maximum rating on the site)

 Indicates that the circulation pump is operating for central heating.

 Indicates that 230V is supplied to the boiler. **If not shown 230V is not supplied to the boiler.**

The system is filled with Glycol before leaving the factory however you should still check to ensure it is filled with Glycol before starting the boiler, check the expansion tank level. The fluid should be 20mm above the minimum mark when cold.

Ensure adequate LPG Propane, 230V and 12V supplies are connected and turned on. The control panel should be active and display the 230V connection symbol.

Turn the boiler 'On' using the control panel, then scroll across and raise the desired room temperature to + 30°C. The circulation pump symbol should appear. Visually check in the expansion tank that the pump is operating.

Scroll across and turn on the 2kW electric heater using the panel. Wait for 10 minutes and check that the upper flow pipe on the

boiler is getting hot. The bottom return pipe may also be warm.

Scroll back and turn on the gas burner using the control panel. You might not be able to hear it start, so visually check the flue outside to confirm the boiler is operating. Wait for 10 minutes and check the lower return pipe on the boiler. It should now be hot and the boiler fully operational.

If the return pipe is not hot, turn the boiler to 'Off' and locate the air bleeds. Open the bleeds until fluid comes out and then close them. Top up the header tank if needed and then restart the boiler. Check after 5 minutes that the return pipe is hot.

If the lower return pipe is not hot, turn the boiler 'Off' and bleed the radiators. Then turn the boiler 'On' wait 10 minutes and check the lower return pipe again.

NOTE: In the winter or when there is a danger of freezing your fresh water should be drained down. Your central heating is still safe to use even with the fresh water drained down.

REFRIGERATOR

Your caravan is fitted with a refrigerator/freezer combination, details of which are in your Technical Data Booklet.

FOR FULL OPERATIONAL INSTRUCTIONS FOR YOUR PARTICULAR FRIDGE, REFER TO REFRIGERATOR MANUFACTURER'S INSTRUCTIONS USUALLY FOUND IN THE APPLIANCE.

For 12v wiring arrangement, refer to Technical Data.

The refrigerator is not suitable for the proper storage of medications.

THETFORD REFRIGERATOR

Your Coachman caravan is fitted with a N3112A or a N3175A (see caravan model specification for details) which have been specially developed by Thetford for caravans and motorhomes.

Control Panel with touchscreen

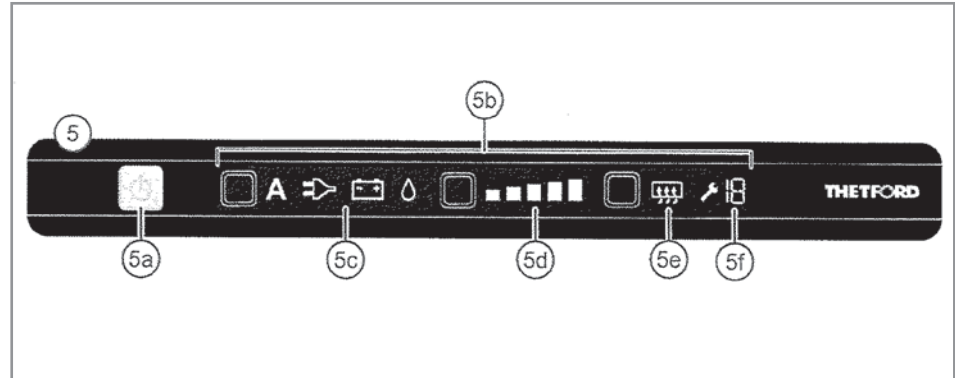

Main Parts

1. Refrigerator door, 2. Freezer door, 3. Door lock, 4 Security lock (dependent on model), 5. Control panel with LCD touchscreen, 5a. On/off switch, 5b. Touchscreen, 5c. Symbols sources, 5d. Cooling level indicators, 5e. Symbol 'anti condensation' (only for model B), 5f. Error code, 6. Freezer compartment, 7. Ice cube tray, 8. Refrigerator compartment, 9. Cooling fins, 10 Storage shelves, 11. Vegetable bin, 12. Serial label, 13 Door bins, 14 Bottle retainer.

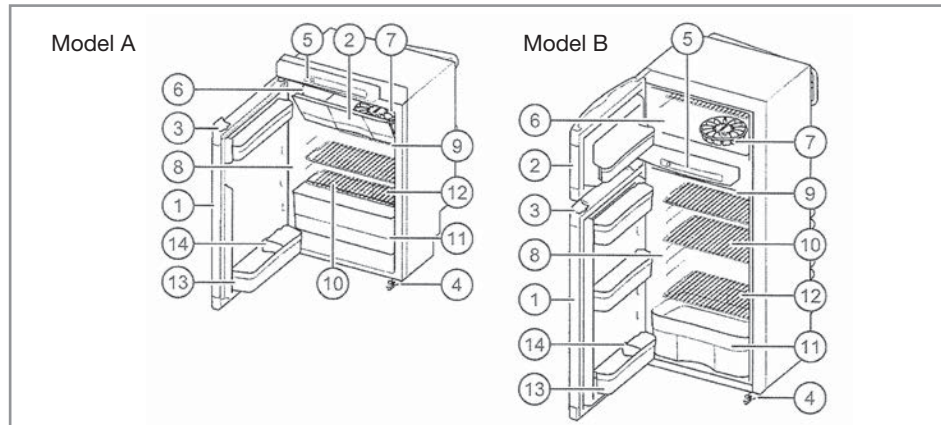

INTRODUCTION

Before operating and using this refrigerator we advise you to read the Thetford manual completely. Keep this manual in a safe place for future reference.

For the latest version of the manual please visit www.thetford-europe.com.

Symbols used



OK



Tip



Special attention required.



Caution (possible risk of injury or product damage)

USE SAFELY

For correct and safe use of this refrigerator, you need to observe several precautions and general recommendations. If these instructions have not been followed, warranty claims will not be accepted.

 **What to do if you smell gas:** Directly close the valve of the gas bottle, extinguish any naked flames, do not switch on any electrical devices or lighting, open the windows and leave the room. Then contact the Customer Service Department in your country or holiday location.



What to do if you smell a pungent odour from the cooling system: Switch off the refrigerator, extinguish any naked flames, provide sufficient ventilation through vents, windows and doors. Then contact the Customer Service Department in your country or holiday location.

MAINTENANCE

- Make sure that installation, electrical connection, maintenance and periodical inspection of the gas system will be done by a qualified technical person, according to Thetford's instructions (www.thetford-europe.com) and local safety rules;
- Never open or damage the cooling system at the back of your refrigerator. The cooling system is pressurised and contains substances that are harmful to your health;
- Never attempt to repair parts of the gas system, the gas flue or electrical components yourself. The repairs may only be done by a qualified party. Please contact the Customer Service Department for further support and addresses;
- Before carrying out any kind of maintenance or cleaning, switch off your refrigerator;
- Never expose the refrigerator to rain.

USE OF GAS

- The refrigerator only runs on liquid gas (propane, butane or a mixture both of these). It does not run on natural gas or coal gas;
- Only use gas which is mentioned on the serial label inside the refrigerator;
- It is recommended to use an additional filter when operating on Liquefied Petroleum Gas (LPG);
- Make sure the type and position of the gas bottle meets the latest technical regulations;
- Change the gas bottle in open air and out of reach of any possible source of ignition;
- Never obstruct the ventilation openings in the gas bottle storage location;
- Keep flammable material away from the refrigerator;
- Do not use gas to power your refrigerator in the vicinity of petrol stations or while driving.

FOOD

- Respect the expiry date printed on the packaging of food;

- Defrosting, cleaning or maintenance of the refrigerator can shorten the preservability of food.

SWITCH ON REFRIGERATOR

i To secure optimal performance, level your vehicle before operating the refrigerator.

↑ We advise to clean the inside of the refrigerator properly, before using your refrigerator.



To switch on the refrigerator, push the on/off switch and hold it for 1 second, as illustrated. A light in the on/off switch will turn green.

⌚ After 10 seconds the settings will dim. The green light indicates the refrigerator is still in function.

⌚ To check the settings push the confirmation button. The last selected settings will light up.

⌚ For optimal performance, switch on the refrigerator 8 hours before placing food.

SELECTING SOURCE

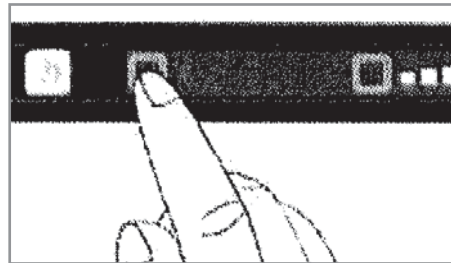

After switching on the refrigerator, push the source button several times, as illustrated

Push until the desired source is selected.

Sources

The refrigerator automatically select the best source available

- | | | |
|---|--------------|--|
| A | Auto | (in order: mains, battery, gas) |
| | 220v
240v | The refrigerator is powered by the mains. |
| | 12v | The refrigerator is powered by the battery of your vehicle. |
| | Gas | The refrigerator is powered by the gas connection of a gas bottle. |

⌚ Always use the gas connection or mains voltage to start up and cool. Operating on 12v is only effective while the engine of the vehicle is running.

⌚ If the 'auto' function on the refrigerator is selected, but no source is available, a light in the on/off switch blinks red.

⌚ The performance of the refrigerator, by operating on 12v, is dependent on the thickness and length of the wiring and the overall installation of the vehicle.

⌚ When selecting gas, the flame should be ignited within 30 seconds. If the system fails, restart the refrigerator and select the gas source again.

⌚ From about 1000m above sea level problems of a physical nature can occur when lighting the gas. This does not mean that the refrigerator is not working properly.

SELECTING COOLING LEVEL

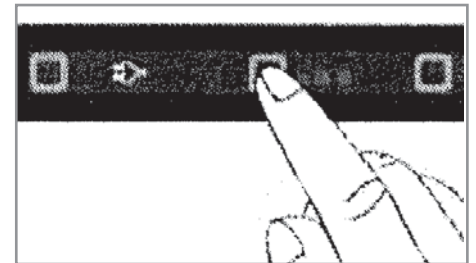



CARAVAN EQUIPMENT

After switching on the refrigerator, push the cooling level button several times, as illustrated. Push until the desired level is selected.



Your refrigerator meets the climate class SN requirements according to EN/ISO 7351 at a temperature of 10°C to 32°C.

 We advise to set the refrigerator on cooling level 3, with an ambient temperature between 15°C and 25°C. A higher temperature needs a higher cooling level, a lower temperature a lower level.

 To improve the cooling performance of your refrigerator in high temperatures, Thetford advises to install the Ventilator Kit. It helps to detract the warm air quicker to the vents. The ventilator Kit is suitable for all Thetford refrigerators.

CONTROL OF OPTIONAL EXTRAS

Anti condensation.

 Present on refrigerator model B

To prevent the control panel from condensation, the anti-condensation function is automatically switched on (no symbol visible). Only switch off this function when little energy is present.

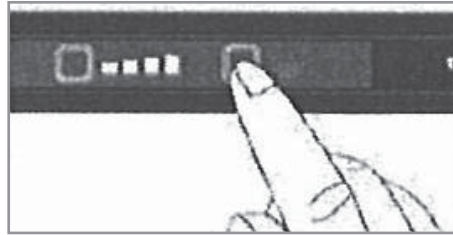

Push on the anti-condensation button. The symbol on the control panel will light up.

USE OF REFRIGERATOR COMPARTMENT

You can organise your refrigerator as desired by moving the storage shelves and door bins in height.

 Make sure the door can still be closed after reorganising shelves and bins.

Moving storage shelves

Turn the plastic clamp on the right side of the storage shelf upwards, as illustrated. Lift the right side of the storage shelf upwards, as illustrated. Lift the right side a bit, and move the storage shelf to the desired position.

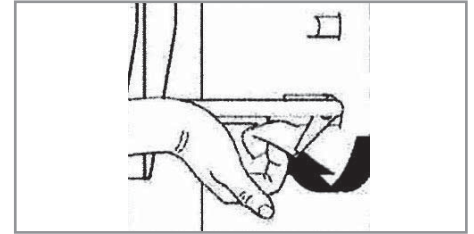

First place the left side of the storage shelf in the refrigerator wall, then the right side in the corresponding groove. Turn the plastic clamp downwards. Your storage shelf is fixated again.

Push a door bin out of the locking with both hands, as illustrated. Place this door bin back in the desired position and push it back on the locking. The door bin is fixated again.

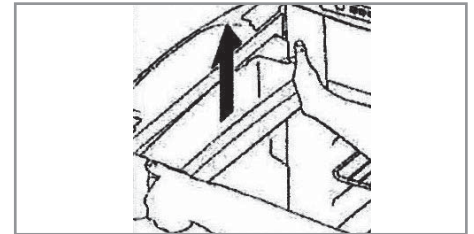

Organising food

After a minimum of 8 hours of cooling, the food can be placed in the refrigerator. Do

not completely cover the cooling fins with food, to preserve an optimal performance of the refrigerator. Make sure air can still circulate around the fins.

⚠ To prevent your refrigerator from ice-formation, always cover liquid products, let warm products cool down before placing them in the refrigerator and don't open the door longer than necessary.

👉 To reduce the cooling time, store only pre-cooled food in the refrigerator.

👉 To prevent the food from drying out or your refrigerator from odours, store food separately in closed boxes.

USE OF FREEZER COMPARTMENT

You can use the freezer compartment to keep food frozen or to make ice cubes with the special delivered tray.

⚠ Never keep carbonated liquids in the freezer compartment.

⚠ If the refrigerator has to perform for a longer period in internal vehicle temperature below 10°C, a constant regulation of temperature in the freezer compartment can't be guaranteed. The temperature can increase and the food may defrost in the freezer compartment.

Making ice-cubes

Fill 2/3 of the ice cube tray with water and put the tray in the freezer compartment. Make sure you only use drinking water.

⚠ Never eat ice cubes or popsicles directly out of the freezer compartment. This can cause burn wounds.

👉 To fasten the process, make ice cubes at night, when the refrigerator has more capacity. Place the ice cube tray in an empty freezer on the bottom and the back.

WHILE DRIVING

⚠ Never operate the refrigerator by gas while driving.

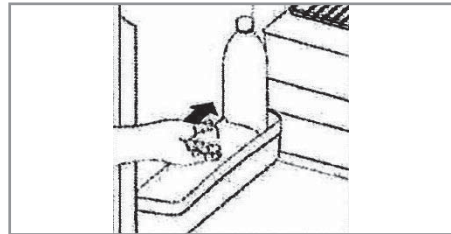

Make sure all products in your refrigerator can't move while driving. Secure the bottles in the door with the bottle retainer and fixate all food on the storage shelves.

Door lock

When you close and press the door of the refrigerator, the door locks automatically. While driving this door lock also secures the door.

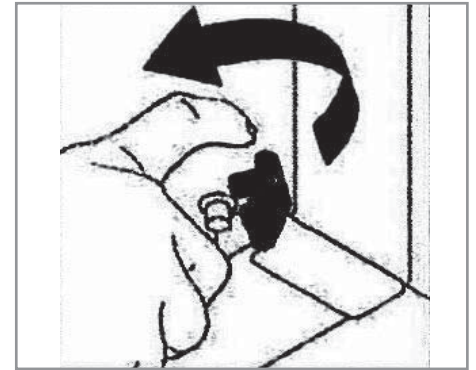

Some models have an extra security lock on the bottom of the refrigerator. To be sure the door will not open while driving, push the black security lock over the pin on the door.

⚠ Never let children play or hide in the refrigerator. Children can be trapped and possibly suffocate.

CARAVAN EQUIPMENT

WINTER USE

When you are going to use the refrigerator with an outside temperature below 10°C, install a suitable winter cover, as illustrated.

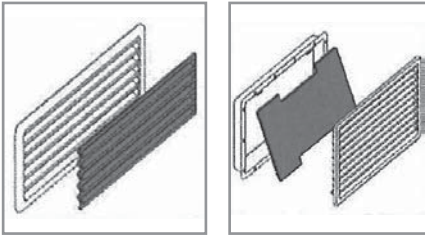

This cover will protect your refrigerator against too cold air and makes sure the refrigerator will still perform optimally.

⚠️ Make sure you remove the winter cover again once the temperature is above 10°C.

CLEANING

It is important to regularly clean the refrigerator for optimal performance. Clean the inside with a soft cloth and mild household cleaner. Use a wet soft cloth for the outside of the refrigerator. Make sure the vents on the outside of the vehicle are always dust-tight.

⚠️ Never clean your refrigerator with soap or aggressive, caustic or soda-based cleaning agents.

⚠️ The loose parts of the refrigerator are not suitable for the dishwasher.

⚠️ Water through the vents may damage your refrigerator. Therefore install winter covers before washing your vehicle.

SWITCH OFF REFRIGERATOR



Before defrosting the refrigerator or storing your vehicle, switch off the refrigerator. Push the on/off switch, as illustrated, and hold it for 2 seconds to switch off the refrigerator. All lights will go out.

DEFROSTING

A layer of ice on the cooling fins will decrease the cooling capacity and durability of your refrigerator. Therefore your refrigerator is provided with an automatic defrost system, which prevents ice formation.

Despite this system, it is also possible to manually defrost your refrigerator on occasion. Remove all food, wrap it tightly in

newspaper and put it on a cold place or in an insulated bag. Then open the doors. Put dry towels in the refrigerator to catch the remaining water. When the refrigerator is defrosted, thoroughly dry the inside.

⚠️ Do not speed up the defrosting process by removing the ice layer with force or sharp objects or by using a hairdryer.

STORAGE

If you do not expect to use your refrigerator for a longer period, it is important to thoroughly empty, defrost and clean the complete refrigerator. Then install the winter cover over the vents, to protect your refrigerator during storage

⚠️ To prevent odours and mould in the refrigerator, keep all doors open during storage.

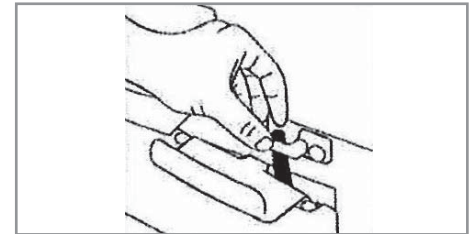

Rotate the hook at door lock 45 degrees and lock it in place by using the strike plate, as illustrated.

 Make sure the gas taps of the gas bottle are closed during storage.

 Water through the vents may damage your refrigerator. Therefore install winter covers before washing your vehicle.

DISPOSAL

Your refrigerator has been designed and manufactured with high quality materials and components, which can be recycled and reused. The cooling system contains ammonia as the coolant and ozone friendly cyclopentane as the blowing agent in the foam. The refrigerators are free of any CFCs/HCFCs and HFCs.

When your refrigerator has reached its end of life, dispose the product according to the local rules. Do not dispose the refrigerator with normal household waste. The correct disposal of your old product will help prevent potential negative consequences to the environment and human health.

QUESTIONS

If you require further information or have any questions about your refrigerator, please visit Thetford website www.thetford-europe.com. If you still have questions, contact the Customer Service Department in your country or your holiday location

For correct and efficient support, please ensure all relevant product type information is available refer to Thetford handbook.

Troubleshooting

In case of a problem an error code on the control panel can light up. When error codes 1, 2, 4, 5, 8, 9 12 or 13 are visible, directly contact your Dealer or a Thetford Service Centre.

3 The refrigerator does not work on gas:

Check if the gas bottle is not empty – check if the valve of the gas bottle and all shut-off valves are open – switch the refrigerator off and on again- try to run the refrigerator on another power source.

6 The refrigerator does not work on 12 V:

Make sure the engine is running – try to run the refrigerator on another power source.

7 The refrigerator does not work on 12 V:

Make sure the engine is running – try to run the refrigerator on another power source.

10 The refrigerator does not work on 230 V:

Check if the mains is available – try to run the refrigerator on another power source.

11 The refrigerator does not work in AUTO mode:

Check if the sources are connected – try to run the refrigerator manually on a power source.

18 All symbols on the control panel light up:

Wait a few seconds until the refrigerator starts normal.

FAQ

What can I do, when the refrigerator does not start?

Check if you switched on the refrigerator according to the instructions, if the vehicle stands level or if there is an available energy source to start the refrigerator with. If none of this is the case, please contact your Dealer or Thetford Service Centre.

The refrigerator does not cool sufficiently, what can I do?

Check if the vents aren't covered or blocked from the outside, if the refrigerator stands level, if the highest cooling level of the refrigerator is selected, if the door of the refrigerator still closes properly or if there is not too much ice on the cooling fins. If none of this is the case, please contact your Dealer or a Thetford Service Centre.

CARAVAN EQUIPMENT

All lights on the control panel are blinking, what should I do?

Please contact your dealer or a Thetford Service Centre

No winter cover is supplied with my refrigerator is this correct?

The winter cover is an accessory for your refrigerator, which you can purchase at your Dealers.

Spare Parts

Original Thetford spare parts are available through your own Dealer or an authorised Thetford Service Centre.

WARRANTY

Thetford BV offers the end users of its products a three-year guarantee. In the case of malfunction within the warranty period, Thetford will replace or repair the product at its discretion. In this case, the costs of replacement, labour costs for the replacement of defective components and /or the costs of the parts themselves will be paid by Thetford.

1. To make a claim under the guarantee, the user must take the product to his Dealer or an authorised Thetford Service Centre (www.thetford-europe.com). The claim will be assessed there.

2. Components replaced during repair under guarantee become the property of Thetford.

3. This warranty does not prejudice current consumer protection laws.

4. This warranty is not valid in the case of products that are for, or are used for, commercial purposes.

5. Guarantee claims falling into one of the following categories will not be accepted:

The product has been improperly used, or the instructions in the manual have not been followed; - the product has not been installed in accordance with the instructions; - alterations have been made to the product; - the product has been repaired by an unauthorised Thetford Service Centre; - the product code or serial ID has been changed; - the product has been damaged by circumstances outside the normal use of the product.

6. The guarantee is only valid for Thetford refrigerators that are built in a caravan.

Thetford is not liable for any loss and/or damage caused directly or indirectly by use of the refrigerator.

OVEN, HOB AND GRILL

Your caravan is fitted with one of the Thetford CK 13000 3 burner hotplate duel fuel cookers.

Introduction

This appliance has been installed in accordance with the local, national and European regulations in force. Particular attention has been given to the requirements regarding ventilation. Read the instructions before using the appliance.

Thetfords policy is one of continuous development and improvement. Specifications and illustrations may change subsequent to publication.

Provision of Ventilation

The use of a gas cooking appliance results in the production of heat and moisture in a room in which it is installed. Ensure that the kitchen is well ventilated, keep natural ventilation holes open or install a mechanical ventilation device (mechanical extractor hood).

Prolonged intensive use of the appliance may

Before using the appliance for the first time, remove all accessories and packing in the grill and oven, including any plastic surface protection film.

Clean all surfaces with hot soapy water to remove any residual protective covering of oil and rinse carefully.

call for additional ventilation, for example opening a window, or more effective ventilation, for example increasing the level of mechanical ventilation where present.

Operation

The burners on this appliance have fixed aeration and no adjustment is required. The burners should flame as follows:-

Propane – The flames should burn quietly with a blue/green colour with no sign of yellow tips.

Butane – Normally on initial lighting, a small amount of yellow tipping will occur. This then increases slightly as the burner heats up.

Using the Hotplate Gas Burners

1. Ensure gas cylinder/supply is connected and turned on. In the event of a gas smell turn off at gas cylinder/mains and contact supplier.
2. Flame supervision: Each burner is controlled individually and is monitored by a thermocouple probe. In the event of the burner flames being accidentally extinguished, turn off the burner control and do not attempt to re-ignite the burner for at least one minute.
3. To light: Push in the control knob and turn to full rate.

4. Your hob is fitted with Spark Ignition and can be ignited by depressing the ignition button, which is located on the fascia. If the burner has not lit within 15 seconds the control knob should be released and the burner left for at least 1 minute before a further attempt to ignite the burner.

5. For simmering, turn the knob further anti-clockwise to the low rate position.

Each burner will support pans from 10 to 22cm care should be taken not to overload the appliance as performance may be reduced.

The following pan sizes are the maximum we recommend:-

Electric Hotplate 180mm

Auxiliary Burner 200mm

Semi-Rapid Burner 2 x 200mm or 1 x 220mm with 1 x 180mm

When using small pans the flames should not spread beyond the base of the pan as this will reduce the efficiency of the burner.

Avoid old or misshapen panes as these may cause instability.

The lid must be opened fully prior to using the hotplate burners.

6. To turn off: Turn the control knob until the line on the control knob is aligned with the dot on the control panel. Always make sure the control knob is in the off position when you have finished using the hotplate burners.

Using the Electric Hotplate

Ensure the electricity is switched on. The hotplate control is numbered from 1 to 6. To turn it on, rotate the knob either clockwise or anti-clockwise to the required position. Position 1 is the coolest setting. To turn off, rotate the knob until the line or pointer on the knob lines up with the zero on the control panel.

The hotplate is a sealed construction and transfers heat through conduction. For maximum efficiency a correctly sized pan with a flat heavy gauge base should be used. Pan size should be the same or slightly larger (up to 1 1/2.5cm oversize).

Before using your hotplate for the first time, we recommend that you prime and season it.

To prime the Hotplate.

Switch on the hotplate for a short period, without a pan, to harden and burn off the coating.

Use a medium to high setting for 3 – 5 minutes. A non toxic smoke may occur during this process. Allow it to cool, then season.

CARAVAN EQUIPMENT

To season the Hotplate.

First heat the hotplate for 30 seconds on a medium setting, then switch off. Pour a minimal amount of unsalted vegetable oil onto a clean dry cloth or paper towel and apply a thin coat of oil to the hotplate surface. Wipe off any excess, then heat the hotplate on a medium setting for 1 minute. Occasional seasoning will help to maintain the Hotplate's appearance.

Ensure the glass lid is open before turning on the hotplate burners.

Children should be supervised to ensure they do not play with the appliance.

Glass lids may shatter when heated. Turn off the hotplate and allow it to cool before closing the glass lid.

Remove all spillage from the surface of the glass lid before opening.

The glass lid has the tendency to snap shut towards the end of lowering. This is caused by the travel lock action of the hinges as it is activated.

Make sure all fingers are removed from appliance when closing the lid.

Using the Grill

1. Ensure gas cylinder/supply is connected and turned on. In the event of a gas smell turn off at gas cylinder/mains and contact supplier.
2. To light: Open door, push in the control knob and turn to full rate. Hold a lighted match or taper to the burner and push the control knob in and hold. The burner should ignite and the control knob should be held for 10 – 15 seconds before release. If the burner goes out, repeat procedure holding control knob for slightly longer.
3. For models fitted with Spark Ignition the procedure is similar except that the burner can be ignited by depressing the ignition button, which is located on the fascia. Ignition must be carried out with the door open and if the burner has not lit within 15 seconds the control knob should be released and the grill left for at least 1 minute before a further attempt to ignite the burner.
4. Note: the grill must only be used with the door open.
5. On first use of the grill, it should be heated for about 20 minutes to eliminate any residual factory lubricants that might impart unpleasant smells to the food being cooked. A non-toxic smoke may

occur when using for the first time so open any windows and turn on mechanical ventilators to help remove the smoke.

6. Although the grill does heat up quickly, a few minutes preheat is recommended.
7. Flame Failure Device (FFD): the grill burner is fitted with a flame sensing probe, which will automatically cut off the gas supply in the event of the flame going out. In the event of the burner flames being accidentally extinguished, turn off the burner control and do not attempt to re-ignite the burner for at least one minute.
8. It is normal for the flames on this burner to develop yellow tips as it heats up.
9. Reversible grill pan trivet enables the correct grilling height to be achieved.

Fast Toasting	trivet in high position
Grilling Sausages	trivet in high position
Grilling Steak/Bacon	trivet in high position
Grilling Chops etc	trivet in low position
Slow Grilling	trivet removed
10. To turn off: Turn the control knob until the line on the control knob is aligned with the dot on the control panel. Always make sure the control knob is in the off position when you have finished grilling.

△ The grill area can get hot when the oven is in use, even if the grill is switched off.

Care should be taken when removing pans from the grill, i.e. use of oven gloves, and by making use of the removable grill pan handle

The grill pan supplied is multi functional for use in grill or oven.

The handle design allows removal or insertion whilst the pan is in use.

Always remove the handle when the pan is in use.

The grill MUST only be used with the door open.

Using the Oven

The appliance is fitted with a cooling system. The cooling fans will automatically switch on a few minutes after the grill and/or oven is turned on, and will remain on even after the appliance has been switched off.

The fans will automatically switch off a few minutes after the appliance has been switched off, when the front of the appliance has cooled sufficiently.

A constant 12 V supply is necessary at all times to ensure the cooling system operates correctly.

1. Ensure gas cylinder/supply is connected and turned on. In the event of a gas smell turn off at gas cylinder/mains and contact supplier.
2. To light: Open door, push in the control knob and turn to full rate (240°C)
3. Your oven is with Spark Ignition and can be ignited by depressing the ignition button, which is located on the fascia. Ignition must be carried out with the door open, and if the burner has not lit within 15 seconds the control knob should be released and the oven left for a least 1 minute before a further attempt to ignite the burner.
4. Place the oven shelf in the required position and close the door.
5. Set the control knob to required temperature. Although the oven heats up quickly, it is recommended that a 10 minute preheat be allowed. The oven should be up to full temperature in about 15 – 20 mins.
6. To turn off: turn the control knob until the line on the control knob is aligned with the dot on the control panel.
7. Shelf: the shelf has been designed to allow good circulation at the rear of the oven and is also fitted with a raised bar to prevent trays or dishes making contact

with the back of the oven. To remove a shelf, pull forward until it stops, raise at front and remove.

Before first use, heat the oven for about 30 minutes at 200°C, to eliminate any residual factory lubricants that might impart unpleasant smells to the meals being cooked. A not-toxic smoke may occur when using for the first time so open any windows and turn on mechanical ventilators to help remove the smoke.

The pans and trays supplied with this appliance are the maximum sizes recommended for use. Larger panes and trays may restrict good circulation of heat, increasing cooking times.

Always ensure food is properly cooked prior to serving.

Oven Temperature Control

The temperature in the oven is controlled by a thermostatic gas tap and is variable over the range 130°C to 240°C. Approximate temperatures for the settings on the control knob are shown in the table below. The temperatures indicated refer to the centre of the oven and at any particular setting the oven will be hotter at the top and cooler towards the base.

The variation between top and centre, and centre to bottom is approximately equivalent

CARAVAN EQUIPMENT

to one gas mark. Good use can be made of the temperature variation in several dishes requiring different temperatures may be cooked at the same time. In this way maximum

Cooking Guidelines

Best results will be obtained by the shelf

positions in this guide. Although the oven heats up quickly, it is recommended a 10 minute preheat be allowed. The oven should reach full temperature in 15 – 20 minutes.

Most cookery books give details of the shelf positions and gas mark settings for each recipe. If in doubt about a recipe you intend

to use, study the recipe carefully then find a similar dish in our guide and use our shelf position and gas mark setting recommendation. Shelf positions are from the top down. When roasting with aluminium foil care must be taken that the foil does not impair circulation or block the oven flue outlet.

Gas Mark	Temperature (Centre – Shelf Pos. 2)				Dish	Temp (°C)	Shelf Position	Cooking Time
¼ -½	265 - 275°C	130 - 135°C	Very Cool	Meringues	Very rich Fruit cake	150	2	Approx. 60 mins per 500g
1	285	140	Cool	Stewed fruit	Baked custard	165	3	50 – 60 mins
2	300	150	Cool	Rich fruit cake	Victoria sandwich	180	2	20 – 30 mins
3	330	165	Warm	Baked custard	Small cakes	195	2	15 – 25 mins
4	355	180	Moderate	Victoria sandwich	Shortcrust pastry	210	2	15 – 55 mins
5	385	195	Fairly hot	Whisked sponges	Scones	220	2	8 – 15 mins
6	410	210	Hot	Short crust pastry	Puff pastry	230	2	15 – 30 mins
7	430	220	Hot	Bread, scones	Beef	165	3	25 mins per 500g plus 25 mins
						220	3	15 mins per 500g plus 20 mins
8	445	230	Very hot	Puff pastry	Pork	165	3	30 mins per 500g plus 35 mins
						220	3	25 mins per 500g plus 25 mins
9	465	240	Very hot	Quick browning				

Do's and Don'ts

- DO read the user instructions carefully before using the appliance for the first time.
- DO allow the oven to heat before using for the first time, in order to expel any smells before the introduction of food.
- DO clean the appliance regularly.
- DO remove spills as soon as they occur.
- DO always use oven gloves when removing food shelves and trays from the oven.
- DO NOT allow children near the cooker when in use. Turn pan handles away from the front so that they cannot be caught accidentally
- DO NOT allow fats or oils to build up in the oven trays or base.
- DO NOT use abrasive cleaners or powders that will scratch the surfaces of the appliance.
- DO NOT under any circumstances use the oven as a space heater.
- DO NOT put heavy objects onto open grill and oven doors.

Leaks

If a smell of gas becomes apparent, the supply should be turned off at the cylinder.

IMMEDIATELY

- Extinguish naked lights including cigarettes and pipes.
- Do not operate electrical switches
- Open all doors and windows to disperse any gas escape.
- Never check for leaks with a naked flame, leak investigation should be carried out using a leak detector spray.
- Check the gas is not escaping from an unlighted appliance.

MAINTENANCE

This appliance needs little maintenance other than cleaning. After the unit has cooled all parts should be cleaned using warm soapy water. Do not use abrasive cleaners, steel wool or cleansing powders. When cleaning the burner ring it is essential to ensure that the holes do not become blocked. The control knobs are a push fit and can be removed for cleaning. They are interchangeable without affecting the sense of operation.

SERVICING

All servicing must be carried out by an approved competent person. Before any service work is started the appliance should have been left to cool and be disconnected from both the gas and electrical supplies. After each service the appliance must be checked for gas soundness.

For service, please contact your authorised local Service Agent giving details of the model and serial number on the data badge plus date of purchase.

Shut off gas supply at isolating valve, switch off electric supply and ensure all parts are cool before cleaning or servicing.

All servicing must be carried out by an approved competent person.

After each service the appliance must be checked for gas soundness.

This appliance must not be modified or adjusted unless authorised and carried out by the manufacturer or his representative. No parts other than those supplied by the manufacturer should be used on this appliance.

If the supply cord is damaged, it must only be replaced by the manufacturer or his representative in order to avoid a hazard.

CARAVAN EQUIPMENT

MICROWAVE

Certain model caravans are fitted with a microwave oven for usage instructions please refer to the Manufacturers Operation Manual and Cookbook. We would however draw your attention to the following important safety instruction and information.

Under no circumstances should the microwave be operated with the cupboard in the closed position.

IMPORTANT SAFETY INSTRUCTIONS

Please read carefully and keep for future reference.

Oven Use:

- The oven is for domestic food use only.
- Never operate the oven when empty.
- Do not leave or store anything inside the oven when not in use.
- Never attempt to use the oven with the door open. It is important not to force or tamper with the door safety latches.
- Never operate the oven with any object caught in the door.

- Do not insert fingers or objects in the holes of the door latches or air-vent openings as this may damage the oven and cause an electric shock.
- If water or food drops inside the air vent openings switch off the oven immediately, unplug it and call an approved service facility.

WARNING: Never allow children to use the oven without adult supervision.

WARNING: Liquids and other foods must not be heated in sealed containers since they are liable to explode. Microwave heating of beverages can result in delayed eruptive boiling, therefore care has to be taken when handling the container. Stir the liquid prior to and during heating/reheating, let liquid stand for at least 20 seconds in the oven after cooking.

FIRE: If smoke is observed, switch off and unplug the appliance and keep the door closed in order to stifle any flames.

HOW YOUR OVEN WORKS

Microwaves are energy waves, similar to those used for TV and radio signals.

Electrical energy is converted into microwave energy, which is directed into the oven cavity via a waveguide. To prevent food and grease entering the waveguide it is protected by the waveguide cover.

Microwaves cannot pass through metal, because of this the oven cavity is made of metal and there is a fine metal mesh on the door. During cooking the microwaves bounce off the sides of the oven cavity at random.

Microwaves will pass through certain materials, such as glass and plastic, to heat the food.

Water, sugar and fat in food absorb microwaves which cause them to vibrate. This creates heat by friction, in the same way your hands get warm when you rub them together.

Once cooking is complete the oven automatically stops producing microwaves.

Standing time is necessary after cooking, as it enables the heat to disperse equally throughout the food.

NOTE: Microwaves are not designed to run continuously for over 20 minutes.

SMOKE ALARM

The smoke alarm fitted to your caravan is approved for use in caravans and motor homes. The National Caravan Council (NCC) requires that all new or used touring caravans sold by its members be fitted with a smoke alarm featuring an alarm silence facility.

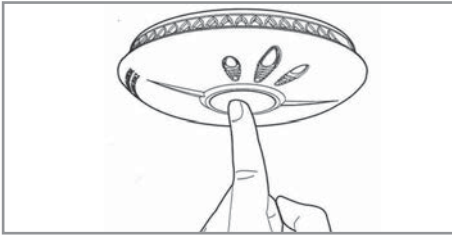

WARNING

Test smoke alarm operation after caravan has been in storage, before each trip and at least once per week during use.

NOTE: A different smoke alarm to the one illustrated may be fitted (subject to availability) but it still meets the criteria above.

For further information on use of the alarm, battery replacement, testing etc., refer to the manufacturer's literature contained in the Owner's Information Pack.

POISONOUS GAS ALARM

Introduction

The CO9X 7 Year Life Carbon Monoxide Poisonous Gas Alarm which is fitted to your caravan is one of a new generation of domestic life safety products from FireAngel Limited, which combines the latest technology and innovative design to provide an aesthetically pleasing and effective contribution to your home safety.

The FireAngel range of products is constantly being improved and expanded. Please visit www.fireangel.co.uk to find out about the latest additions to our product range.

FireAngel manufactures some of the most technologically advanced carbon monoxide detectors in the world.

Operating Features

- An advanced electrochemical sensor designed to accurately measure low levels of carbon monoxide (CO) providing an early warning of toxic CO levels in your home.
- Detects carbon monoxide continuously.
- Resistant to false alarms caused by normal household contaminants.
- Sounds a loud 85dB alarm (at 1 metre (3

feet)) to alert you in case of an emergency.

- Test/reset button.
- Regular self-check to ensure detector is operating correctly.
- Simple to mount, portable, ideal for travelling.
- Independently tested to confirm to the European Carbon Monoxide Alarm Standard BS EN 50291 : 2001.
- 7 year warranty

Carbon Monoxide and how it can affect you and your family.

Carbon monoxide is a dangerous, poisonous gas that kills hundreds of people each year and injures many more. It is often referred to as the silent killer because it has no odour or taste and cannot be seen. Like oxygen, CO enters the body through the lungs during the normal breathing process. It competes with oxygen by replacing it in the red blood cells, thereby reducing the flow of oxygen to the heart, brain and other vital organs. In high concentrations CO can kill in minutes.

Many cases of reported carbon monoxide poisoning indicate that while victims are aware they are not feeling well, they become disorientated and unable to save themselves by either exiting the building or calling for

CARAVAN EQUIPMENT

assistance. Exposure during sleep is particularly dangerous because the victim usually does not wake up.

Symptoms of CO poisoning

The following symptoms may be related to CO poisoning which all household members should be made aware of:

- Mild Exposure: Slight headache, nausea, vomiting, fatigue (often described as 'flu-like' symptoms).
- Medium Exposure: Severe throbbing headache, drowsiness, confusion, fast heart rate.
- Extreme Exposure: Unconsciousness, convulsions, cardiorespiratory failure, death.

Your FireAngel CO detector monitors the level of CO as parts per million (ppm) in the atmosphere surrounding the detector.

35ppm The maximum allowable concentration for continuous exposure for healthy adults in any 8 hour period, as recommended by the Occupational Safety and Health Administration (OSHA)

200ppm Slight headache, fatigue, dizziness, nausea after 2 – 3 hours.

400ppm Frontal headaches within 1 – 2 hours, life threatening after 3 hours.

800ppm Dizziness, nausea and convulsions within 45 minutes. Unconsciousness within 2 hours. Death within 2 – 3 hours.

Should you suspect CO may be affecting you and your family, open the doors and windows of your caravan to ventilate, turn off your appliances and evacuate the caravan. At this time the authorities should be contacted to locate the source of the carbon monoxide before re-entering the caravan. Medical attention should be sought for anyone suffering the effects of CO poisoning.

Common sources of CO

- Oil and gas boilers
- Portable generators
- Oil or solid fuel cookers
- Gas or paraffin heaters
- Barbecues
- Clogged chimneys
- Wood or gas fireplaces
- Cigarette smoke
- Gas appliances
- Any fossil fuel burning appliance

WARNING

This FireAngel carbon monoxide detector is not a combustible gas detector, nor a smoke detector

WARNING

Do not use this carbon monoxide detector on an intermittent basis, or as a portable detector for trying to trace one source of the spillage of combustion products from fuel-burning appliances or from chimneys.

DO NOT:

- IGNORE ANY WARNING FROM YOUR CO DETECTOR!
- Burn charcoal inside your home, caravan, tent or cabin.
- Install, convert or service fuel-burning appliances without proper knowledge, skill and expertise.
- Use a gas cooker for heating a room.
- Operate unvented gas burning appliances using paraffin or natural gas in closed rooms.
- Operate petrol-powered engines indoors or in confined areas.
- Barbecue indoors, or in an attached garage.

- Ignore a safety device when it shuts an appliance off

ALWAYS

- Buy appliances accepted by a recognised testing laboratory.
- Install appliances according the manufacturer’s instructions.
- Have appliance installations carried out by professionals (for gas appliances engineers should be registered on the Gas Safe register)
- Have your appliances checked regularly by a qualified service engineer.
- Have your chimneys and flues cleaned professionally every year.
- Make regular visual inspections of all fuel-burning appliances
- Open windows when a fireplace or oil/solid fuel cooker is in use.
- Only install CO detectors that meet the requirements of BS EN 50291:2001 in your home
- Be aware of CO poisoning symptoms.

EDUCATE YOURSELF AND YOUR FAMILY ON THE SOURCES AND SYMPTOMS OF CO POISONING AND HOW TO USE YOUR CARBON MONOXIDE DETECTOR.

POWER PACK ACTIVATION

See Diagram below

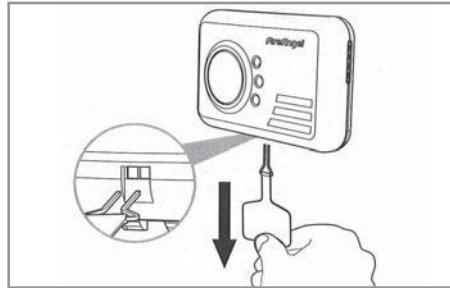

- a. Your detector comes complete with an integrated power pack that will provide power for its entire operational life. To activate the power pack you need to pull the disabling tab (see image). This will in turn pull out the metal disabling clip, which is attached to the end of the tab, from the disabling socket which is situated on the underside of the detector. Retain the disabling tab for future use.
- b. When the detector is activated the Power LED will begin to flash green once every minute to indicate that the detector is receiving power from the power pack and is fully operational.
- c. Test the sounder, power pack and circuitry by pressing and holding the centre of the

Test/Reset button briefly to confirm that the detector is operating properly. The sounder will sound as soon as the button is pressed and the Alarm LED will illuminate red indicating that the sounder is working and the power pack is providing power to the unit. This test for the sounder, power pack and circuitry should be performed on a weekly basis. This should be continued for the lifetime of the product.

WARNING

Prolonged exposure to the sounder in close proximity to your ears may damage your hearing.

Under normal operating conditions, the power pack will last for the lifetime of the product i.e. 7 years.

The detector will not protect against the risk of carbon monoxide poisoning when the power pack has drained.

WARNING

Constant exposure to extreme high or low temperatures may reduce the life of the power pack.

POWER PACK DE-ACTIVATION

Your CO-9X is portable, making it ideal for taking with you on holiday. You will need to

CARAVAN EQUIPMENT

deactivate your detector when travelling or even when storing e.g. when decorating. Fitting is the reverse of removal. To deactivate the detector the two ends of the metal clip must be inserted into the corresponding holes in the disabling socket located on the underside of the detector (see image). You can ensure that the product is disabled by pressing the test button – if there is no sound from the sounder then clip has been fitted correctly.

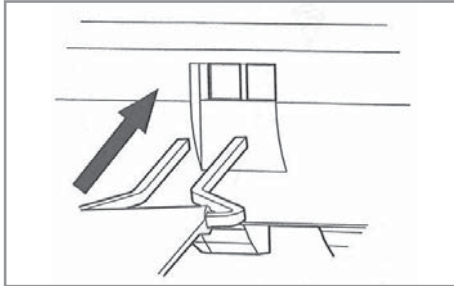

NOTE: If the disabling tab is no longer available then the clip can be replicated by opening out a thin metal paper clip into a U-shape.

Your FireAngel detector offers many features which set it apart from other CO detectors on the market today.

Test/Reset button feature

This button will:

- Test the sounder, power pack and circuitry
- Allows you to test the sensor by introducing a source of CO into the detector (See 'Testing the Sensor' below).
- Silence the loud 85dB (at 1 metre (3 feet)) sounder during an alarm (only for alarms due to levels of CO of less than 50ppm)

Testing the sounder, power pack and circuitry

Test the sounder, power pack and circuitry by pressing and releasing the Test/Reset button to confirm that the detector is operating properly. The sounder should sound as soon as the button is pressed, and the Alarm LED will illuminate red indicating that the sounder is working and the power pack is providing power to the unit. This test for the sounder, battery and circuitry should be performed on a weekly basis.

Testing the sensor

NOTE: We suggest the use of an incense stick or cigarette as the inefficient way in which these products burn means the smoke given off contains a detectable localised amount of carbon monoxide. Alternative sources of smoke, for example an extinguished candle or match, will not

contain sufficient levels of carbon monoxide to obtain a response from the detector during this test. Please note your CO detector will not detect smoke.

CAUTION: Sensor testing should only be performed by a responsible adult. This test should only be performed once a month. Excessive testing will cause the life of the power pack to be shortened.

NOTE: CO test kits may be used in order to avoid having to burn cigarettes, incense sticks etc. However we recommend that incense sticks are used as they are cheap and readily available.

• Read all steps thoroughly before attempting the sensor test.

- Step 1 If the detector is wall or ceiling mounted unhook the detector from the screws.
- Step 2 Cover the sounder vents with one hand. Press and hold the Test/Reset button down with your thumb/finger until the Fault LED illuminates yellow and the sounder sounds for a second time (this should happen after around 5 seconds). Release the Test/Reset button. Upon releasing the Test/Reset button the Fault LED will flash yellow once every second. This indicates that the sampling rate of the detector has increased and

can be tested using a known source of CO.

Step 3 Light a cigarette or an incense stick using a match or lighter. If using an incense stick be sure to blow out the flame so that the incense stick is smouldering. Extinguish the lighter, or put out the match and place it in a dish of water.

Step 4 Turn the detector on its side so that the vents on the right hand side of the detector are pointing downwards (See diagram). Hold the burning cigarette or incense stick 15 – 20cm (6 – 8 inches) below the detector, so that the smoke enters the vents on the side of the detector. An increase in the localised carbon monoxide level within the sensor to more than 50ppm will cause the sounder to sound for one cycle of four loud beeps and the Fault LED to illuminate yellow for a short time.

This will end the test.

The Fault LED will no longer flash yellow and the detector will go back to normal operating mode i.e. the Power LED will flash green once every minute (it may take up to two minutes of exposure to the smoke for the localised level of carbon monoxide within the sensor to reach

over 50ppm). Now move the source of CO away from the detector as the test is finished.

Step 5 After step 4, put out the incense stick or cigarette by placing it into a dish of water. Ensure that all flames have been extinguished.

NOTE: If the localised carbon monoxide level within the sensor does not reach 50ppm during the test, the sensor test will stop automatically after 3 minutes.

UNDERSTANDING THE PRODUCT'S INDICATOR

The higher the concentration of carbon monoxide detected by the detector, the quicker it will respond. When sufficient carbon monoxide is detected a loud audible signal *8.5 dB at 1m (3 feet) will be emitted and the Alarm LED will flash red once every second.

The Alarm will sound:

- Between 60 and 90 minutes when exposed to 50ppm of CO
- Between 10 and 40 minutes when exposed to 100ppm of CO
- Within 3 minutes when exposed to 300ppm or more of CO.

Fault/low power pack signal:

The unit continuously checks the settings of its sensor and circuitry. If any of these settings are found to be incorrect or if the power pack becomes low then the detector will emit a **single chirp** once per minute and the Fault LED will flash yellow once per minute for up to 30 days.

IMPORTANT:

This does NOT mean that the detector has detected carbon monoxide.

If the product is still within warranty then contact technical support. If the product is no longer in warranty **replace immediately!**

IMPORTANT:

The selected power pack was chosen to provide power beyond the lifetime of the product, in particular the sensor (under normal operating conditions). The sensor life is seven years. For this reason, the detector should be replaced after seven years from the date of installation.

FireAngel Technical Support Line
9.00am – 5.00pm, Monday – Friday.

Telephone: 0800 141 2561

UK Textphone Users Telephone: 18001
0800 1414 2561

Eire dial: 1-800 523171

e-mail: technicalsupport@fireangel.co.uk

CARAVAN EQUIPMENT

MAINTAINING/TESTING YOUR DETECTOR

Maintenance

Your detector will alert you to potentially hazardous CO concentrations in your caravan when maintained properly. To maintain your FireAngel detector in proper working order, and to ensure that the sensor will last for the lifetime of the product, it is recommended that you:

- Test the sounder, power pack and circuitry of your detector at least once per week by pressing the Test/Reset button briefly.
- Perform the Sensor Test once every month.
- Keep the detector free of dust by gently vacuuming the case with a soft brush attachment once per month.

To prevent the possibility of contaminating the sensor in your detector and thus affecting its reliability:

- Never use cleaning solutions on your detector. Simply wipe with a slightly damp cloth.
- Do not paint the detector
- Do not spray aerosols on or near the detector

- Do not use any solvent based products near the detector.
- Move the detector to a safe location and store in a plastic bag before performing any activities using substances that emit strong fumes. Remember to remove it from the bag and replace the detector when these activities are finished.

Failure of any test should be reported to the Technical Support Team.

Do not attempt to repair your CO detector. Do not remove any screws or open the main casing of your detector. Any attempt to do so may cause malfunction and will invalidate the warranty.

WHAT TO DO IN THE EVENT OF AN ALARM

WARNING

A loud alarm is a warning that unusually high and potentially lethal levels of carbon monoxide are present. Never ignore this alarm, further exposure can be fatal. Immediately check residents for symptoms of carbon monoxide poisoning, and contact the proper authorities to resolve all CO problems. **NEVER IGNORE ANY ALARM.**

Please carefully review the owner's manual to ensure that you know what actions to take in the event of an alarm.

What to do during an alarm

- Keep calm and open the doors and windows to ventilate the caravan.
- Turn off appliances where possible and stop using the appliances.
- Evacuate the caravan leaving the doors and windows open.
- Ring your gas or appliance supplier on their emergency number, keep the number in a prominent place.

Write your fuel supplier's emergency number here

- Do not re-enter the property until the alarm has stopped. When exposed to fresh air it can take up to 10 minutes for the sensor to clear and the alarm to stop depending on the level of carbon monoxide detected.
- Get medical help immediately for anyone suffering the effects of carbon monoxide poisoning (headache, nausea), and advise that carbon monoxide poisoning is suspected.
- Do not use the appliance again until it has been checked by an expert. In the case of gas appliances the engineer must be registered on the Gas Safe register.

Thetford C260

See Thetford quick guide supplied

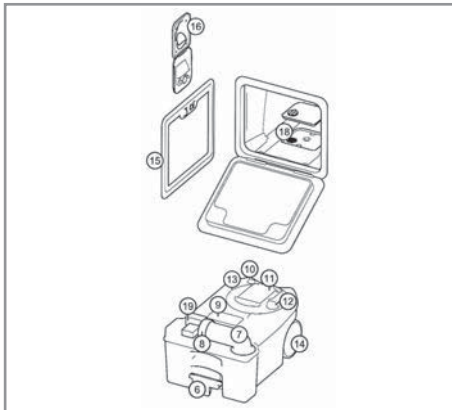
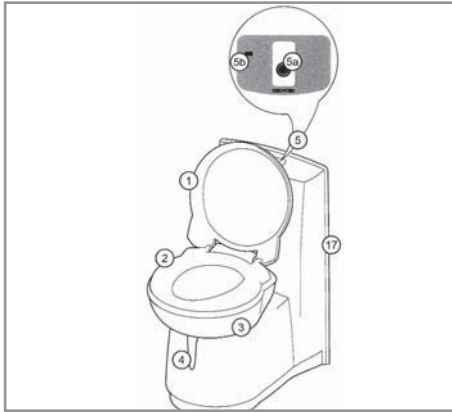

Main Parts

Standard

1. Cover. 2. Seat. 3. Swivelling toilet bowl.
4. Blade handle to open/close blade. 5. Control panel (position is different from C263 models). 5a. Flush button. 5b. Waste-holding tank level indication. (1 level or 3 levels dependent on model). 6. Pull handle.
7. Pour out spout. 8. Cap with measuring cup. 9. Automatic pressure release vent.
10. Vent button. 11. Sliding cover. 12. Blade opener. 13. Waste holding tank mechanism. 14. Wheel. 15. Service door/3.

Options

16. Waterfill door (only for C262 model).
17. Filter for electric ventilator.
18. Console with flush water tank (only for C262 model).
19. Location waste pump-out system.

Introduction

This Thetford cassette toilet is a high quality product. It is user friendly, meets high quality standards and gives you all the convenience of home.

Before operating and using this toilet we advise you to read the Thetford manual completely. Keep this manual in a safe place for future reference. For the latest

version of the manual please visit www.thetford.eu

Symbols used

✓ OK

☞ Tip

ⓘ Special attention required

⚠ Caution (possible risk of injury or product damage).

Preparing for use

This cassette toilet has a waste holding tank of 17.5LA C262 model has its own 8L flush-water tank. Before using your toilet, it is vital that you add toilet additives to these tanks. Check the correct dosage on the additive package. The add ±3L of water to the waste holding tank. Fill the flush-water tank of a C262 model to the top.

⚠ **Never add toilet additives directly via the blade as this could damage the lip seal of the waste-holding tank via the pour out spout.**

⚠ **Never force if you cannot get the waste-holding tank back into place easily. If blockage occurs, always check if the blade handle is in the closed positions.**

CARAVAN EQUIPMENT

 Thetford offers a pleasantly scented toilet flush for the flush-water tank (Aqua rinse) and a variety of waste holding products (Aqua Kem Blue, Aqua Kem Green, Aqua Kem Natural, Aqua Kem Sachets)

Aqua rinse keeps the flush water fresh, ensures a smooth slush and leaves a protective layer. All products for the waste-holding tank suppress unpleasant smells, stimulate the breakdown of waste, reduce the formation of gas, protect moving parts and help to keep the waste-holding tank fresh and clean. For the differences between distinguishing qualities of each waste holding tank product please visit www.thetford.eu.

The range of toilet products may vary for each country.

Use of your toilet

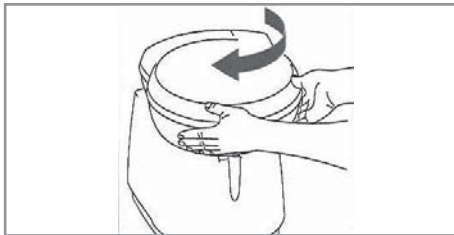

Turning the bowl

You can turn this bowl to a desired position (max ± 90).

Close the cover and use both hands to rotate the bowl as illustrated.

Opening the blade



The toilet can be used with the blade open or closed. To open the blade, slide the blade handle sideways as illustrated. Make sure you always close the blade completely after use.

Flushing the toilet

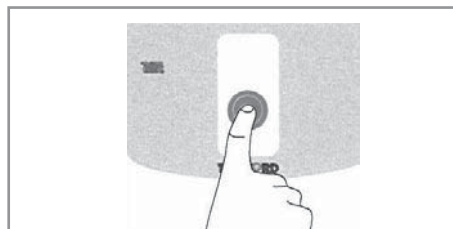

Press the flush button once to activate the control panel. Then press the flush button for several seconds to flush the toilet.

 **Ordinary toilet paper can cause clogging. Use Aqua Soft toilet paper instead. This toilet paper is super-soft, dissolves quickly, prevents clogging and makes it easier to empty the waste holding tank.**

Level indication

You can check whether your waste holding tank has a 1 level or a 3 level indication. Make sure the tank is empty and place it back properly. The activated the control panel. If no level indication light lights up, you toilet has a 1 level indication. It will only indicate a full tank. If a green level indication light immediately lights up, you toilet has a 3-level indication. It will empty half full and full.

Emptying Tank

Waste-Holding Tank

When the red light to the level indicator on the control panel lights up, you need to empty the waste-holding tank. Remove the tank via the service door. Then take it to an authorised waste disposal point. Empty the waste holding tank via the pour out spout.

 To empty the tank without splashing, press and hold the vent button with your thumb while the pour out spout is pointing downwards.

If you want to continue using your toilet after emptying, prepare the waste-holding tank gain.

 Aqua Kem Green, Aqua Kem Natural and Aqua Rinse (Test ISO-11734) are absolutely safe to empty into a septic tank or small biological systems on camping sites.

 Please avoid to travel with a waste-holding tank that is more than $\frac{3}{4}$ full. This may cause leakage through the venting system.

Flush Water Tank (only for C262 models)

The flush water tank has a capacity of 8L. Only empty the flush water tank completely if you don't expect to use your toilet for a long time (winter) period.

Place a sufficiently large bowl under the drain tube and catch the remaining water. Empty this bowl at an authorised waste disposal point.

See Thetford quick guide diagrams 33 -38 for visual reference.

 **To prevent water damage to your caravan, ensure that you don't travel with a full flush water tank, or with water in the bowl.**

Cleaning

Just like your toilet at home, it is also important to clean this cassette toilet regularly. You will prevent limescale and ensure optimal hygiene. Clean the inside of the bowl with toilet bowl cleaner and a soft brush and use bathroom cleaner for the outside of the toilet.

 **Never use household cleaners to clean your toilet. These may cause permanent damage to the seals and other toilet components.**

Remove seat and cover

To clean your toilet thoroughly, remove the seat and cover. First push the seat and cover together to the right, then lift them up.

Winter Use

You can use your toilet as normal in cold weather as long as the toilet is situated in a heated location. If this is not the case and there is a risk of frost, we advise not to use your toilet. Make sure you completely empty the waste-holding tank. For a C262 model also empty the flush-water tank.

Aqua Kem Sachets are particularly suitable for winter camping as the sachets are filled with powder. They completely dissolve in water, are easy to dose and economical in use.

Maintenance

To prolong the life of your toilet, maintain your toilet regularly. Use cassette tank cleaner 2 or 3 times a year on the waste-holding tank. It safely removes stubborn limescale on the inside of the tank. When seals become dry, use seal lubricant to keep the seals soft and pliable. It has been specially developed for mobile toilets and is absolutely safe to use.

 **Never use Vaseline or vegetable oil to lubricate the seals as this may cause leakage to your waste-holding tank.**

Storage

If you don't expect to use your toilet for a long period, you have to thoroughly empty, clean and dry the whole toilet.

Also empty the flush-water tank of a C262 model. This is also a good moment to maintain you toilet.

During storage we advise leaving the blade open to prevent damage to the blade and to loosen the cap of the pour out spout to ventilate the waste holding tank.

Questions

If you require further information or have any

CARAVAN EQUIPMENT

questions about your toilet please visit www.thetford.eu.

Spare Parts

Original Thetford spare parts are available through your own dealer or an authorised Thetford Service Centre.

FAQ

What should I do in case of a defect on my Thetford toilet?

Contact your Dealer where you bought your caravan or, if you are on holiday, contact an authorised Thetford Service Centre.

A red light on the control panel flashes, what should I do?

Check if the waste-holding tank is present or positioned properly.

I cannot move waste-holding tank.

Check if the blade of your toilet is completely closed.

What should I do when the electric blade doesn't function?

Manually open or close the blade by sliding the small handle under the toilet bowl sideways.

What should I do if the blade is blocked?

Loosen the cap with measuring cup from the

pour out spout and try again.

Does the toilet have a fuse?

Yes, the toilet has a maintenance-free self-resetting fuse.

Warranty

Thetford BV offers the end users of its products a three-year guarantee. In case of malfunction within the warranty period, Thetford will replace or repair the product at its discretion. In this case, the cost of replacement, labour costs for the replacement of defective parts and/or the costs of the parts themselves will be paid by Thetford.

1. To make a claim under this guarantee the user must take the product to his Dealer or authorised Thetford Service Centre (www.thetford.eu). The claim will be assessed there.
2. Components replaced during repair under guarantee become the property of Thetford.
3. This warranty does not prejudice current consumer protection laws.
4. This warranty is not valid in the case of products that are for, or are used for, commercial purposes.

Guarantee claims falling into one of the

following categories will not be accepted.

- The product has been improperly used or the instructions in the manual have not been followed (for example incorrect use of additives).
 - The product has not been installed in accordance with the instructions.
 - Alterations have been made to the product.
 - The product has been repaired by an unauthorised Thetford Service Centre.
 - The product code or serial ID has been changed.
 - The product has been damaged by circumstances outside the normal use of the product.
5. Not using Thetford products to care for your Thetford toilet could create some damage, which would not be covered by this warranty.

Thetford is not liable for any loss and/or damage caused directly or indirectly by use of the toilet.

ROOF LIGHTS

When opening the roof lights, care must be taken to release the locking mechanism as the unit is raised.

Roof lights must be fully closed when towing.

When closed roof lights still provide fixed ventilation.

Roof lights provide a maximum 11,500mm of fixed ventilation each.

WINDOWS

All opening windows have two catch positions. The first position is for ventilation the second seals the window from ventilation and rain.

THE OMNIVENT 12 VOLT ROOFLIGHT FAN

Use Rooflight

- Close the lid before driving.
- To take away the roller blind, unscrew and click the frame off at the side of the knob.

Use of the Ventilator

- The ventilator is started by the soft switch S2. The middle LED light lights up and the ventilator starts in comfort mode, this is the lowest speed (extract). See Fig. 1.

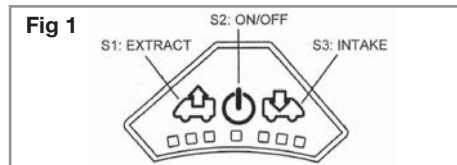

Table 2

PUSH BUTTOMS	LIGHTS	SPEED	Ampère	Watt
	■ ■ ■ ■ ■ ■ ■ ■	0	0,2 mA	2,4 mW
1x	■ ■ ■ ■ ■ ■ ■ ■	1	0,15 A	2 W
1x + 1x	■ ■ ■ ■ ■ ■ ■ ■	2	0,35 A	5 W
1x + 2x	■ ■ ■ ■ ■ ■ ■ ■	3	0,65 A	9 W
1x + 3x	■ ■ ■ ■ ■ ■ ■ ■	4	1,20 A	17 W
1x + 4x	■ ■ ■ ■ ■ ■ ■ ■	5	1,70 A	24 W
1x + 5x	■ ■ ■ ■ ■ ■ ■ ■	6	2,50 A	34 W
1x + 5x + 1x	■ ■ ■ ■ ■ ■ ■ ■	5		
1x + 5x + 2x	■ ■ ■ ■ ■ ■ ■ ■	4		
... ..				
1x	■ ■ ■ ■ ■ ■ ■ ■	0	0,2 mA	2,4 mW

PUSH BUTTOMS	LIGHTS	SPEED	Ampère	Watt
	■ ■ ■ ■ ■ ■ ■ ■	0	0,2 mA	2,4 mW
1x	■ ■ ■ ■ ■ ■ ■ ■	1	0,15 A	2 W
1x + 1x	■ ■ ■ ■ ■ ■ ■ ■	0	15 mA	0,2 W
1x + 2x	■ ■ ■ ■ ■ ■ ■ ■	1	0,15 A	2 W
1x + 3x	■ ■ ■ ■ ■ ■ ■ ■	2	0,30 A	5 W
1x + 4x	■ ■ ■ ■ ■ ■ ■ ■	3	0,50 A	9 W
... ..				

CARAVAN EQUIPMENT

- By pushing on the switch S1 (extract) or S3 (intake), the airflow can be adjusted in 6 steps. See Table 2.

*MIN = 3,7 m3 /min. (2W – 0,17 A)

*MAX = 24 m3/min. (86 W – 7,20 A)

- In order to save the battery, the speed drops from position 6 to the lowest position after one hour of use.
- It is possible to allow the ventilator to work for 5 minutes on the highest speed (boost). To do this push for 3

seconds on the button S1 (extraction) or S2 (intake). After 5 minutes the ventilator returns to its previous speed setting. See table in Fig. 3.

- For reasons of security, the ventilator stops when the tension is too high (19,5v) or too low (11,1v) or when the fan is blocked. For trouble shooting see Fig. 4.

MAINTENANCE

The ventilator grid can be removed for cleaning. Also the mosquito screens can be taken out for cleaning.

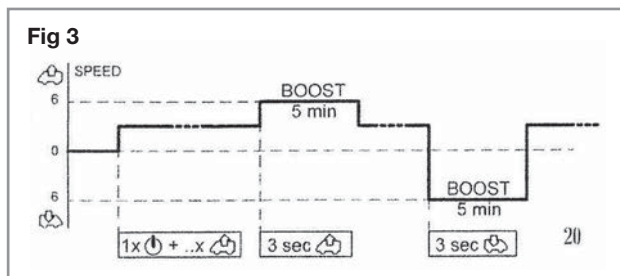

The roof light is only waterproof in the direction of the traffic. When transporting the caravan in the opposite direction or when the back of the caravan is up, ensure the dome is watertight by using the 'Lock-unlock' (not supplied on a ventilator version) or by using something that ensures that the dome remains closed when being transported.

THE HEKI 2 ROOFLIGHT

The Heki 2 roof lights provide a maximum of 13,200mm of fixed ventilation.

Fig 4 TROUBLE SHOOTING

FLASHING LED'S	PROBLEM
■ ■ ■ ■ ☼ ■ ■ ■ ■	or Tension < 11,1 V or Tension > 19,5V
☼ ■ ■ ■ ■ ■ ■ ■ ☼	Motor blocked
■ ■ ■ ☼ ■ ■ ☼ ■ ■	Motor not connected

1. To open to the tilted position:

- Press the button in the toggle catches on either side of the dome and turn through approx. 90°.
- Grasp the metal bar in the middle, snap it out of its holder, swivel down and push the dome upwards.

(Dome is held by the two gas springs after approx. 150mm).

- Swivel the metal bar towards the dome and snap into its holder.

- To close the dome, proceed with steps (a-c) in reverse order.

2. To open in the intermediate position:

- Open the toggle catches on either side of the dome.
- Grasp the metal bar in the middle, snap it out of its holder, swivel down and push the dome outwards.

(Dome is opened automatically by the two gas springs after approx. 150mm).

- Open both black fasteners and swivel the metal bar toward the intermediate position and pull the dome down until the metal bar is stopped by the fasteners.

- To close, proceed with steps (a-d) in reverse order.

3. To open in the ventilation position:

- a) Open the toggle catches on either side of the dome.
- b) Using both hands on the two toggle catches, press the dome up about 2cm and fasten the toggle catches in the corresponding setting.
- c) To close, proceed with steps (a-b) in reverse order.

4. Closing the blinds:

- a) Pull blind across aperture using finger grip in the bar. Engage with plastic clip on the other side of the aperture.

CAUTION In extremely bright sunshine, the blackout blind must only be closed two-thirds, and the pane must be set in the intermediate position.

- b) Select the required position (black-out/flyscreen) by moving both joined end rods together.

5. Opening the blinds:

- a) Move blind (end rod with rocker) right to the outside.
- b) Hold the recessed grip with one hand; with the other hand, press the rocker and move the blind back (do not let it recoil).
- Suitable for a max. of 100km/h (62.5mph) (with Seitz spoiler up to 130km/h (81mph)).

Opening / closing the dome:

- press the push button (1) and simultaneously open the dome with the bar (2).

Position "A"

- push the bar (2) to the marked rest position (●).

- Fix the bar in the rest position by pushing the sliders (3), left and right, downwards.

Position "B"

- push the bar (2) to the marked position (●) and lead over the locking mechanism left and right by applying slight pressure.

Position "C"

- push the bar (2) to the marked rest position (●).
- applying slight pressure, lead the bar (2) over the catch hook (4) left and right so that the dome is locked and the bar (2) lies on the push button (1).

Position "D"

- push the bar (2) to the marked position (●)

Opening / closing the blinds

- push the blind (5) in the direction of the arrow (A) and the flyscreen (6) in the direction of the arrow (B).

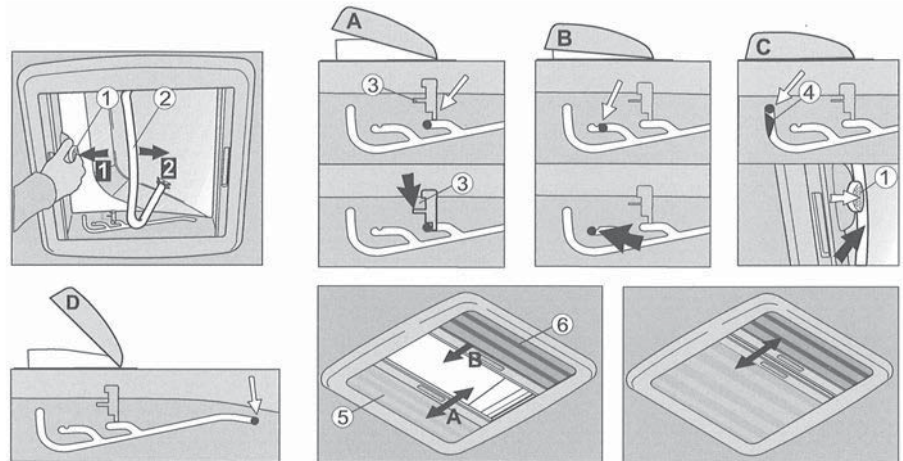

CARAVAN EQUIPMENT

- Do not stand on the acrylic glass dome.
- Close HEKI 2 completely before moving off.
- Do not leave your caravan when HEKI 2 is open.
- Please consult your supplying dealer if you have any problems or defects.
- Remove any snow/ice or dirt before opening the roof.

Care Instructions

Clean the acrylic (glass) pane only with Seitz acrylic cleaner or soap suds and plenty of water.

Use talcum to care for the rubber seals.

Only use water and mild soap suds to clean the blinds.

The guarantee becomes null and void if these instructions are not followed.

MINI HEKI ROOFLIGHT

The Mini Heki Rooflight will provide a maximum of 7500 mm² of fixed ventilation.

Safety precautions:

1. Repairs should be carried out only by trained personnel.
2. Inform an approved dealer in case of

defects and malfunctions.

3. Before starting off, check the rooflight for damage in the dome (tension cracks) and the opening mechanism which could arise owing to, for example, branches and other natural causes.
4. Do not step on the dome.
5. Close the rooflight before starting off (check whether it is locked).
6. Do not leave the vehicle with the rooflight open (danger of burglary).
7. Do not open in strong wind or rain.
8. Before opening, remove snow, ice, dirt, etc. from the dome
9. Malfunctions are to be repaired by an approved dealer at once.
10. Do not use caustic detergents (danger of tension cracks in the dome).
11. Before setting off close the dome, check the locking mechanism and open the blinds.

Care instructions

- Clean the dome with the Seitz acrylic cleaner.
- Opaque spots and light scratches on the dome can be removed with the Seitz Acrylic Polish and the Seitz special

polishing cloth.

- Use talcum powder regularly (four times yearly) to care for the rubber seals supplied with versions without permanent ventilation.
- Clean the blinds only with water and mild suds.

The guarantee becomes null and void if the care and safety instructions are not followed.

MIDI HEKI

Intermediate position of dome

By pushing the bar into the marked rest position, two extra opening angles, apart from the one in which the dome is fully opened, can be chosen.

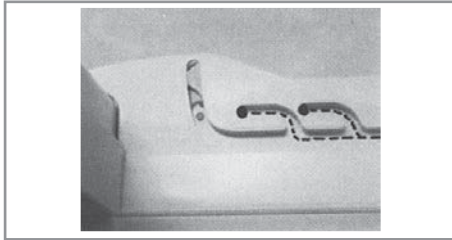

Closing the dome (Drive and rest position)

Push the bar with hands on the right and the left side in such a way that the hook bolts (1) the dome on the left and the right side and the bar lies on the push button (2). Check if the dome is locked.

Opening/closing the blind and fly net

Pull the end rod from the recessed part and push it in a position you desire. (Both systems are adjustable in any positions and can be used independently from each other).

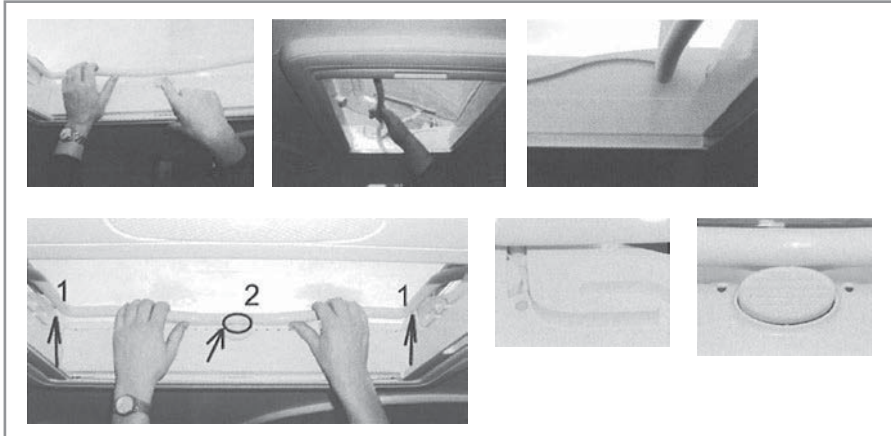
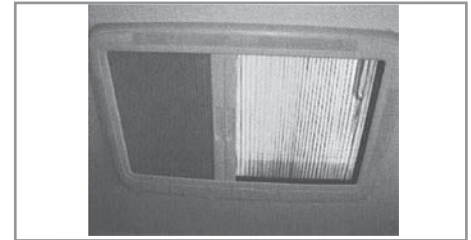

Safety precautions

- Repairs should be carried out only by trained personnel.
- Inform an approved Dealer in case of defects and malfunctions.
- Before starting off, check the roof light for damage in the dome (tension cracks) and the opening mechanism which could arise owing to, for example branches and other natural causes.
- Do not step on the dome.

CARAVAN EQUIPMENT

- Do not leave the vehicle with the rooflight open (danger of burglary and water penetration).
- Do not open in strong wind, rain or snowfall.
- Before opening remove snow, ice, dirt etc from the dome.
- Malfunctions are to be repaired by an approved Dealer at once.
- Do not use caustic detergents (danger of tension cracks in the dome).
- Before setting off close the dome and check the locking mechanism.
- Avoid high speed (maximum recommended speed is 130km/h).
- Before starting off open the blind.
- Do not close the blind more than 2/3 during the day (Danger of heat jam).

Care Instructions

- Clean the dome with the Seitz acrylic cleaner.
- Opaque spots and light scratches can be removed with Seitz Acrylic polish and the Seitz Special polishing cloth.
- Use talcum powder regularly (4 times a year) to care for the rubber seals.

- Clean the blinds only with water and mild soap suds or a vacuum cleaner.

The guarantee becomes null and void if the care and safety instructions are not followed.

WINDOW BLINDS

Pull blind down by its centre catch. Do not pull down by one side of the blind. This will inevitably lead to problems. Do not allow blinds to spring back freely. Always control them by hand.

FLYSCREENS

To operate the flyscreen, either pull the screen fully down or fully up, dependant on type of window fitted. To release – if a cross bar is fitted, gently pull the cross bar downwards towards you and allow the tension of the spring to roll up the flyscreen. Where a cross bar is not fitted, disconnect from the blind catch and release gently.

It is recommended that blinds are in the open position whilst the caravan is moving.

Winterisation

The blind/flyscreen should not be left in the down position throughout the winter as the memory of the mechanism may be lost.

GAS BARBECUE POINT

Your caravan is fitted with a gas barbecue point.

The gas barbecue point, is situated on the nearside towards the front. This point is for use with a gas barbecue only.

Simply lift up the flap, unplug the red plastic end cap and connect the appliance in accordance with the gas barbecue manufacturer's instructions. Turn the gas supply valve on.

NOTE: The connection cannot be undone unless the gas supply valve is first turned off.

CAUTION! Do not use a gas barbecue inside the awning. ALWAYS use the appliance in the open air.

ENTERTAINMENT SYSTEMS

Your caravan is fitted with a CD/MP3 or DVD/MP3 player. For instructions on how to set up and use this equipment, you should refer to the Sony Handbook you have received with your information pack. For service, Warranty support and technical queries you should contact Base Systems at the number shown on Page 104 of this handbook

AV/TV CONNECTIONS

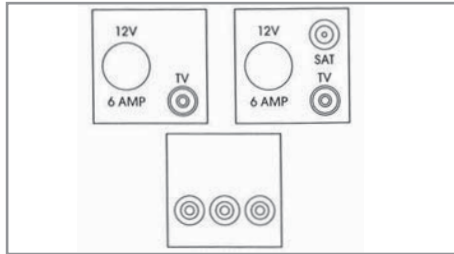

For TV 12 volt supply + arial connection.

VISION PLUS STATUS 550 DIGITAL ANTENNA

Please read these instructions carefully. Incorrect installation will affect the performance of your Status

Technical:

Antenna Dome	
Length	530mm
Width	340mm
Height	125mm
Mounting Foot	
Diameter	122mm
Height	35mm
Amplifier	157 x 45 x 29mm
Frequency Range	UHF 470-860 Mhz
Antenna Forward Gain	7db
Amplifier Gain	16db

Gain Adjustment	15db
Noise Figure	2.8 db
Output Impedence	75 ohms
Output	92 dbuV
Power Supply	12-24 vDC
Power Consumption	90 ma
Signal Outputs	2 TV 1 Radion

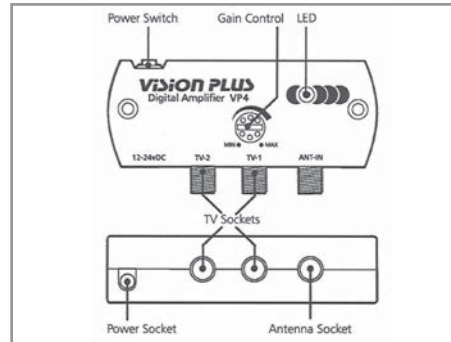
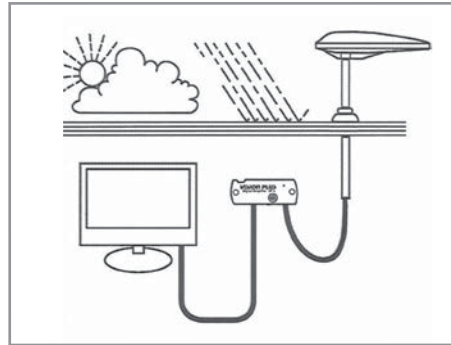

OPERATING THE SYSTEM.

Travelling

When positioning the Antenna Dome please allow for the following:-

DO NOT TRAVEL:-

- With the Antenna raised.
- With the Antenna set for vertical signals.

To reduce the possibility of damage when travelling, have the antenna pointing towards the rear of your caravan/motor home.

Operating

1. Loosen the Mast Locking Collar and raise the antenna.
 2. Determine whether the TV transmissions are horizontal or vertical and position accordingly.
 3. Switch ON the Amplifier and the LED will illuminate and check the gain is set to MIN by rotating the button anti-clockwise.
 4. Rotate the antenna.
- RED – Poor signal – keep turning.
 YELLOW – Getting better – slow down.
 GREEN – Signals located, ready to GO
5. If there is no GREEN, increase the Gain and repeat the 360 degree rotation.

CARAVAN EQUIPMENT

- Once the transmitter has been located increase the Gain to MAX.
- Turn on your television set and tune in.
This will be necessary at all new locations.
- Secure the Antenna by hand tightening the Mast Locking Collar.

IMPORTANT

You may detect more than one transmitter.

Choose the position that gives you the most channels when tuning in your TV.

In poor signal areas the LED may only glow YELLOW.

In strong signal areas you may need to reduce the gain by rotating the Control anti-clockwise.

Removing the Antenna

A permanently fitted Status can be easily removed leaving only the Mounting Foot and rubber gaiter.

- Unplug the antenna lead from the Amplifier.
- Loosen the Mast Locking Collar and lift off whilst feeding out the mast, coaxial cable and plug.
- Push the Blanking Cap supplied into place.

IMPORTANT – The Blanking Cap is a temporary seal and is not recommended for long term use.

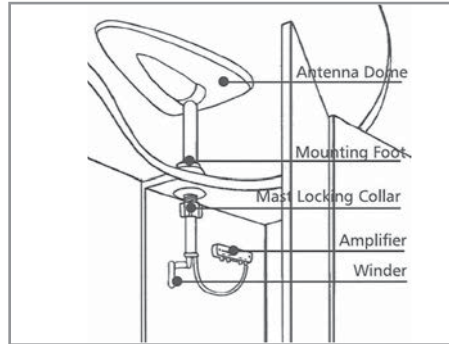

FAULT FINDING

The following are some of the key areas we suggest you check which generally solve the most common problems encountered with the operation of the Status antenna.

Coaxial Connections

It is critical that all connections in the system are fitted correctly. Using the diagrams and procedures described over the page, please check all connectors ensuring they are wired correctly. Secondly please ensure only quality plugs have been used.

Coaxial Cable

Sharp bends, kinks and hot surfaces can easily damage coaxial cable and should be avoided. Coaxial cable, if placed in close proximity to electrical cables, transformers or other pieces of electrical equipment, may pick up electrical interference causing picture quality to deteriorate, especially in poor reception areas. Excess cable should be removed and NOT coiled as this may cause picture distortion. An inspection of the routing of the cable is highly recommended to ensure all is correct.

Gain Control

In normal use the button should be rotated clockwise for maximum. In strong signal areas the amplification may need to be reduced. To reduce amplification rotate the button anti-clockwise until picture quality improves. The button rotates through 270 degrees from MAX to MIN.

LED Light

Should the LED on the Amplifier not light, firstly check there is power to the unit. Secondly check the polarity is correct. Otherwise contact Grade UK Ltd for further assistance.

Short Hook Up – Test 1

This test isolates the wiring from the Amplifier through to your TV/Radio points.

Unplug the coaxial plugs from the ‘TV’ sockets of the Amplifier and using you TV fly lead with Converter 1 supplied. Connect your TV to the Amplifier.

Please ensure the Antenna Dome is plugged directly into the ‘ANT-IN’ socket of the Amplifier and switch on. Tune in your TV for the strongest signal.

If the picture quality improves the fault lies with the wiring of the system between the Amplifier and the TV outlet socket.

Short Hook Up – Test 2

This test isolates the Amplifier by connecting your TV direct to the Antenna.

Unplug the Antenna from the Amplifier and connect Converter 2 supplied to the plug on the cable end. Using your TV Fly Lead connect the antenna directly to your TV. Tune in your TV for the strongest signal.

If the picture quality improves, the fault lies with the Vision Plus Amplifier.

Antenna Dome Co-axial Cable

Check the routing of the coaxial cable from the Antenna Dome to the Amplifier. Check to ensure there are no kinks or trapped cable or if there are loops of surplus cable which could be affecting performance.

SIGNAL	SYMPTOM	ACTION
Very Poor	No picture or sound, TV freezing severe pixilation, break up and picture drop out.	Check the amplifier gain is set to maximum (rotate clockwise). Check antenna alignment which must be directed at the transmitter. Ensure the antennas polarity is correct, whether horizontal or vertical. Bypass the amplifier by following “Short Hook-Up Test 1”.
Poor	Moderate pixilation and sound distortion	
Medium	Minor pixilation, will not receive all channels	
Good	Stable picture, good sound quality, will receive all channels	N/A
Strong	Possible pixilation, picture break up and drop out.	Reduce the amplifier gain (rotate anti-clockwise). Rotate antenna AWAY from the transmitter.
Very Strong	No picture or sound, TV freezing, severe pixilation, break up and picture drop out.	Rotate antenna AWAY from the transmitter. Switch “OFF” the amplifier and turn the gain control to maximum (rotate clockwise).
After performing any of the “Actions” above you must re-tune your TV		

Customer Help Line

Should you still be experiencing difficulties and require assistance, please do not hesitate to contact Grade UK Ltd at the address below.

Grade UK Limited
 8 Finch Close
 Lenton Lane Industrial Estate
 Nottingham
 NG7 2NN

Tel: 0115 986 7151

Email: info@gradeuk.co.uk

www.gradeuk.co.uk

MAINTENANCE

Gaiter

We suggest you periodically check the gaiter for any signs of damage or for wear.

If the rubber is caught by overhead obstructions it may rip or tear which would allow water to work its way into the fabric of the roof.

CARAVAN EQUIPMENT

Over an extended period of time the gaiter will wear at the contact area with the mast. Should the gaiter begin to fail the signs will be small amounts of water dripping down the outside of the mast, however, the design of the Gaiter and Mounting Foot ensures that water cannot work its way into the fabric of the roof. Should this problem occur contact Grade UK Ltd for a replacement unit.

Spares & Repairs

Should you require any parts for replacements or repair please log on to www.gradeuk.co.uk or telephone

0115 986 7151.

GUARANTEE

The Status Antenna has a return to base guarantee against defective parts and workmanship for two years or a period determined by Coachman Caravans. This does not include any malfunction resulting from improper use, incorrect installation, accidental or malicious damage. To support your guarantee claim a dated Proof of Purchase will be required.

This does not affect your statutory rights. Any queries concerning warranty please contact Grade UK Ltd

MOBILE ALARM SYSTEM

(Where fitted)

Introducing the new Sargent **STINGER 310** series modular alarm system.

Based on new technology and a two year design process, the **STINGER 310** incorporates ideas and feedback from users and experts throughout the caravan and security industries.

Designed to be modular, the system can be expanded by a forthcoming range of wired and wireless accessories.

To ensure your **STINGER 310** system is operated correctly, please read all sections of these instructions before attempting to use the alarm. If you are unsure of any content, please contact your supplier in the first instance or the manufacturer direct.

OPERATION – USING THE KEY FOB

Each **STINGER 310** is supplied with two key fob style radio controllers, which are used to operate the alarm system. Each key fob has four buttons which can be used as follows;



LED Torch button

Press and hold the button to use the torch for night time convenience



Arm / Disarm button

Press and release the button to arm the alarm (one beep)

Press and release the button to disarm the alarm (two short beeps)

To arm the alarm without the PIR movement sensor (if you leave pets inside etc)

Press and hold the arm button and release after you hear one beep followed by two beeps



Awning Light button

Press and release the button to turn the awning light on or off.

(NOTE: Awning light control is present in all Coachman Caravan models)



Programming Mode button

Press and hold the button for 10 seconds to access the 3

programming modes, which are indicated by series of long beeps, as follows:

One long beep - Tilt sensor sensitivity adjustment

Press the arm/disarm button to select the required setting. 1 beep = low sensitivity for windy conditions. 2 beeps = standard sensitivity (default). 3 beeps = High sensitivity. Press the program mode button to move to the next setting.

Two long beeps - Beeper volume

Press the arm/disarm button to cycle through the 7 available volume levels.

When you are happy with the selected volume, press the program mode button to move to the next setting.

Three long beeps - PIR movement detector sensitivity

Press the arm/disarm button to select the required setting/pulse count. 1 beep = high sensitivity . 2 beeps = standard sensitivity (default). 3 beeps = Low sensitivity for hostile environments.

Press the program mode button again to exit programming mode, which is indicated by one extra long beep.

OPERATION – THE PIR INTERNAL MOVEMENT SENSOR

The **STINGER 310** comes complete with a 120° Passive Infra Red (PIR) internal movement sensor that detects body movement within the vehicle.

If you are leaving pets within the vehicle the system should be armed without the PIR sensor active (see key fob arm/disarm section) to prevent your pet from triggering the alarm.

Please be aware that direct sunlight onto the PIR lens, or extremes of temperature (above 30 deg C) may affect the operation of the detector. Always ensure roof light blinds are closed if sunlight could shine directly onto the PIR.

OPERATION – THE TILT SENSOR

The **STINGER 310** incorporates a new electronic tilt and motion sensor with automatic calibration and easy sensitivity adjustment from the key fob. This feature provides excellent tilt detection with no moving parts.

The tilt sensor works automatically and does not need adjustment for normal use even if you park on a steep incline. The sensitivity of the sensor can be adjusted as described in the key fob programming section.

OPERATION – AWNING LIGHT

When the **STINGER 310** alarm system is armed or disarmed the Awning light will be activated for a period one minute to provide illumination whilst entering or exiting the caravan. The Awning light can be turned off during this period by pressing the Awning light button on the key fob if required. (note: awning light control is an optional feature present in all Coachman Caravan models)

The Awning light can be turned on or off at any time by pressing and releasing the Awning light button.

BATTERY – SYSTEM BASE UNIT

The **STINGER 310** system unit uses a special 4.8 volt Nickel Metal Hydride battery pack that supplies backup battery power to

the system should the supply from the leisure battery fail or be disconnected. It is recommended that the alarm system is permanently connected to a 12 volt supply. When fully charged the battery will provide approximately 6 months stand-alone operation, depending on temperature conditions. It is recommended that this battery pack is replaced every 3 years.

Before placing your caravan in storage please ensure the caravan has had a fully charged leisure battery fitted or the mains charger switched on for at least 14 days prior to storage to ensure the internal backup battery is fully charged. It is recommended that a leisure battery remains connected to the caravan during storage.

Always dispose of old batteries in accordance with local regulations.

BATTERY – KEY FOB

The **STINGER 310** key fob controllers use two lithium button cells (CR 2032) in each key fob. Please note that excessive use of the LED torch will reduce the life of the batteries considerably.

To replace the batteries, firstly remove the four cross head screws from the underside of the fob, then pull apart the two halves of the fob. Remove the used batteries from the lower half of the case, then insert the new

CARAVAN EQUIPMENT

batteries in the same manner, noting that the battery positive faces away from the green circuit board. Now reassemble the fob casing and refit the screws, taking care not to over tighten.

BEDS AND BUNKS

FRONT DOUBLE BED

The two front single beds can easily be converted into a double bed by **lifting** the offside bed slightly and sliding it towards the nearside bed. However, **prior** to moving the unit, ensure that the backrest is laid flat on the seat base cushion otherwise it will foul the blinds. Arrange the seat appropriately.

All high level beds will take a maximum weight of 10 stone (63.5kg). When in use, the high level beds must have the bunk safety boards in place as shown in diagram 4. Note these are not suitable for children under 6 years old without supervision.

Prior to tilting the single beds to access storage, please ensure the backrest is laid flat on the base cushion.

WARNING.

Please ensure the adjustable feet on the bed are adjusted to touch the floor/carpet so that the bed is completely level and will not put strain onto the bed mechanism in its extended position.

NOTE:

Any failures due to strain caused by non level usage are not covered by warranty

When upper bunks are used by children especially under the age of three, care must be taken against the risk of falling out.

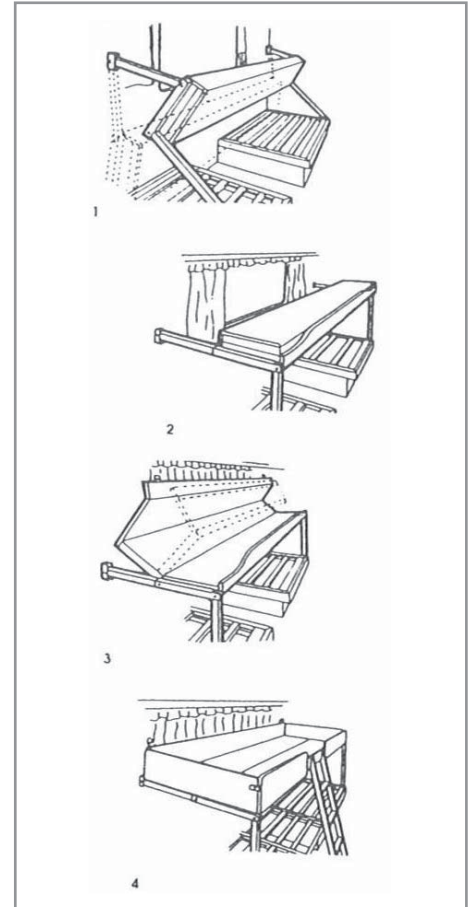

CLEANING

This section of the guide is devoted to the care, cleaning and general preservation of your caravan in order to keep it in good condition.

Exterior

- Side walls of your caravan are finished in acrylic finished aluminium, which is extremely durable and easy to clean. It is recommended that a proprietary brand of vehicle shampoo with plenty of cold water is used.
- Do not use a pressure washer as this can disturb the mastic seals.
- An occasional polish with a good quality vehicle wax will help obtain a high gloss finish. Under no circumstances should an abrasive or harsh cleaner be used. Stubborn marks, such as tar, grease etc., can be removed by rubbing with a soft cloth dampened with white spirit.
- Plastic and ABS panels should be cleaned using water and a mild detergent.

Under no circumstances should alcohol spirit or solvent-based liquids be used on these items, as these substances will react with the material and cause visual damage.

Acrylic Windows

Your caravan is fitted with shatter resistant acrylic windows. To preserve their clarity and unblemished transparency it is essential that the following cleaning instructions are strictly adhered to:

Road grit, dust, sand, flies, lime tree secretions, bird droppings etc., should be 'swilled off' using plenty of cold water. Any remaining dirt should be washed off using a soft cloth and warm water. **Under NO circumstances should any abrasive cleaning agents, household detergents or proprietary cleaning fluids be used. Alcohol spirit or solvent-based liquids must not be used on these items as they will react with the material and cause visual damage.**

Correct removal of scratches from acrylic panes is achieved by using a special polishing cloth and acrylic polishing paste. Light scratches and matt areas can be removed from acrylic by using the acrylic polishing paste and polishing cloth. Distribute the polishing paste on the pre-cleaned surface with the polishing cloth and polish gently in a circular motion for 3-5 minutes. Rinse with warm water. Do not use in strong sunshine. Correct antistatic treatment of the acrylic pane is achieved with an antistatic acrylic cleaner. The acrylic cleaner prevents the static charging and with

it the attraction of dust; it removes among other things, light stains and dust which clings loosely to the pane. Regular care with acrylic cleaner prevents the formation of a film of grime, which might be difficult to remove later, and renews constantly the antistatic effect. Spray the acrylic cleaner on the pane, with an unbroken movement wipe the surface with a fresh polishing cloth (for example: first vertically, then horizontally, but not in a circular motion!). Rub gently do not rub dry, leave to dry naturally. Do not use in strong sunshine. Thus can the acrylic panes be enjoyed again.

It is a popular misconception that caravan windows are vacuum sealed. This is not the case.

The windows in a caravan can be susceptible to condensation if the temperature difference between inside and outside is changed quickly and dramatically, such as when a damp or cold caravan heats up quickly via a heater or the sun. This can be exaggerated particularly if the ventilation is not allowing the temperatures to balance.

The caravan window, unlike a glass window is not completely diffusion-proof, which means it is permeable to the water vapour contained in the air. That is to say that water is initially absorbed from the air on the surface of the panes. The water molecules then penetrate by diffusion into the material

CARE OF YOUR CARAVAN

itself and then end up on the inside of the pane. Here they are absorbed by the air trapped between the two panes. If the water vapour in the air surrounding the window is high enough, this procedure continues until the air in the window is completely saturated.

In view of the fact that the quantity of water vapour which can be absorbed by a volume of air decreases when the temperature falls, as soon as the temperature drops the water condenses at the coldest points of the window where it becomes visible as droplets. When the pane heats up again, the water evaporates. It is in fact still there but invisible. If the air around the window becomes very dry, then the diffusion procedure starts up again through the acrylic in the other direction. Most of the moisture disappears from the window. It should be noted that the diffusion procedure through the window is relatively slow.

It is true condensation can be the result of window delamination but for a quantity of windows to delaminate on the same caravan would be extremely unlikely and the real test is "do the windows eventually clear".

Condensation actually occurs when the humidity inside the caravan exceeds 60% and the ventilation is not sufficient. To help overcome this some of the following actions can be taken:

- Leave the rooflight open.
- Put windows onto night vent position.
- Leave doors between compartments open.
- Keep temperature at night to minimum.
- Increase ventilation above normal in inclement weather.

Interior Walls

Your caravan interior walls are finished with a vinyl coating and will only require a wipe over with a damp cloth, using a mild detergent, to keep them in a good condition.

Furniture

Treat your caravan furniture as you would the furniture in your home. Polish wood surfaces sparingly with a good quality wax polish. Use a damp cloth to clean laminated surfaces.

Your furniture is made from wood or wooden based materials so it requires attention and care to maintain its beauty.

Moisture in air can cause damage to furniture. Wood expands or contracts with an increase or decrease in the relative humidity in the air. The damage can be quite visible if the relative humidity is higher than 80% for a long time. To prevent damage assure the relative humidity of air is not too

high for a long time by ventilating the van.

When wood is wet, wipe it dry. Do not just wait for the sun to dry it. The longer the water stays on the surface, the more damage it can do.

Carpets, Upholstery and Curtains

- Do not use aerosol sprays as the propellant will permanently mark cushions.

Vacuum clean carpets and upholstery to ensure a long life. Marks on cushions can be removed using a mild upholstery shampoo with the minimum of water. Curtains and Upholstery – check the manufacturer's label for care instructions.

DO NOT WASH CURTAINS AND DO NOT WASH OR DRY CLEAN CARPETS.

Argent Stainless Steel Sink

Routine Cleaning

It is good practice to clean equipment immediately after use. Most deposits can be removed by washing with soap or mild detergent and hot water, followed by a clean water rinse and drying with a soft cloth to prevent water spotting. For more tenacious deposits a non-abrasive multi-purpose cream cleaner may be used. This should be applied with a soft damp cloth followed by a

clean water rinse and drying. Stubborn dirt and grease may require the use of nylon scouring pad (such as Scotchbrite), in conjunction with the multi-purpose cream cleaner.

Oil, grease and fingerprints can generally be removed with a soap/water solution but a hydrocarbon solvent may be required.

Care must be taken to use the proper safety precautions if using solvents. Fingerprints, on the glass lid, can be eliminated with a glass cleaner. Removal of the excess cleaner with a soft cloth leaves a protective film from which fingerprints can be wiped.

Tannin (Tea) Stains

Tannin stains can be removed using a hot solution of sodium carbonate (washing soda) and water, alternatively, the solution can be applied with a soft cloth/sponge. This treatment should be followed by a clean water rinse to remove any residues and drying with a soft cloth.

Heat Tinting and Discoloration

Heavy oxidation is unlikely to occur during normal usage. If heat tinting does occur, slight abrasion of the surface will be required and the type of cleaner will depend upon the original finish of the component. A highly polished surface will require the use of a proprietary stainless steel polish but slight

scratching may occur during the polishing treatment. If the finish is directional, as in a ground, brush or dull polish, then a nylon scouring pad/cloth in conjunction with the multi-purpose cream cleaner can be used.

Scratches

Scratching will be most noticeable on highly polished components, in particular the drainer area of sinks where hard objects are likely to be placed during normal household use. These marks are usually only superficial and can be removed with a proprietary stainless steel cleaner/polish. A useful alternative is a car paint restorer, such as 'T-Cut'.

Rust Marks

Under normal usage, it is unlikely that these marks will be caused by rusting of the stainless steel itself, but are more likely to be the result of small particles of "ordinary steel" which have become attached to the surface and subsequently rusted. These brown marks are usually only superficial stains and can be removed by using a soft damp cloth and multi-purpose cream cleaner. Occasionally, it may be necessary to resort to a proprietary stainless steel cleaner, to return the surface to its original condition.

CAUTIONS

- i) Cleaning agents containing sodium

hypochlorite (bleach) should not be left in contact with stainless steel. This includes many of the new "trigger-dispense" cleaning products and some multi-purpose cream cleaners. If bleach is necessary, it should be used only in the strengths prescribed by the manufacturer and never left in contact with the surface for longer than 30 minutes, after which the stainless steel should be rinsed thoroughly with clean water.

- ii) On no account should "wire wool" pads be used unless they are made of stainless steel.
- iii) Harsh abrasives and scouring materials should not be used for cleaning stainless steel as they will leave scratch marks in the surface and damage the appearance of the article. Likewise, do not use wire brushes, scrapers or contaminated scouring pads.
- iv) If the article has a directional polished grain, any cleaning with abrasives should be carried out along this grain and not across it.
- v) After use, always remove wet cleaning aids (such as cloths, pads, containers) from the surface, to avoid formation of water marks/stains.
- vi) Most domestic dishwashing liquids contain chlorides; if they are left in long-term contact with stainless steel, pitting

CARE OF YOUR CARAVAN

corrosion may occur.

vii) Silver Dip cleaners are particularly harmful as they contain strong acids which can very quickly cause discoloration and pitting. If this type of cleaner comes into contact with the surface of a stainless steel article, it should be rinsed off thoroughly with clean water.

Ovens

Only clean ovens with soap and water.

Shower Room and Wash Basin Fittings

Always put the cold water into the wash hand basin before adding the hot. Thermoplastic products such as basins and showers have an adequate but limited resistance to high temperature. 70°C normally should be considered the maximum temperature the products can withstand. Bear in mind the maximum comfortable for human skin is approximately 40°C!

The normal effect of overheating on plastics is distortion of the surface, although perhaps unsightly this does not generally affect the practical application of the product.

The best way to keep the surface clean is by regular conventional soap and water and clear rinsing in cold water. **For stubborn stains Thetford Bathroom Cleaner is recommended.** The use of any other

cleaners may harm the product, cause premature failure and will invalidate the warranty.

Abrasive products should never be used and the same applies to solutions such as nail varnish remover (Acetone), linseed oil based products (such as putty), thinners, pine oil, etc. Thetford Bathroom Cleaner is available from most good Caravan Dealers.

WATER SYSTEMS

The water systems, and in particular storage tanks, in caravans are susceptible to contamination by bacteria if care is not taken with their use and cleaning. The symptoms caused by bacterial contamination are not purely limited to gastro-intestinal diseases, but may also manifest themselves as ear, nose, throat, eye or skin infections. It is therefore important that you carry out the following procedure prior to using the caravan each time, even if you boil or filter all water you use for drinking.

Containers

1. All water remaining in the container should be disposed of so that the container is empty.
2. The outside of the container should be thoroughly cleansed and washed down to remove any dirt, dust or other contaminant. Water at a suitably hot

temperature containing an appropriate detergent is recommended for this purpose.

3. Water should be put into the container swirled round, then emptied out.
4. The container should then be totally filled with water containing an appropriate disinfectant/sterilant solution and allowed to stand for the recommended contact time.
5. The solution should be emptied from the container.
6. The opening of the container should be cleaned thoroughly with an appropriate pre-prepared wipe impregnated with a disinfectant/sterilant.
7. The container should be inverted whilst stored overnight (if possible).
8. The container must be filled with mains water only and mains water only should be used for the above cleaning procedure.
9. On no account should garden hoses be used to fill water tanks.

Systems

1. Drain down the system (Open all taps to allow air in, enabling the system to drain quickly), using the floor mounted drain taps.

2. Remove any water filters fitted, and replace with a short length of hose or empty filter cartridge (this will ensure the filter is not affected by the disinfectant/sterilant solution).
3. Fill the system by using the pump with a disinfectant/sterilant solution. (Check that the solution at full strength appears all taps/showers). Allow to stand for the recommended period of time.
4. Drain the system down completely, as 1.
5. Thoroughly clean the outside of all taps/connectors with a cloth soaked in the disinfectant/sterilant.
6. Flush the system through with clean drinking water until no traces of disinfectant/sterilant can be detected at any tap.
7. Replace the filter.

Suitable sterilising chemicals are available from your caravan dealer, accessory shop, chemists, or home-brew shops. It is not, however, recommended to use bleach or sodium metabisulphide.

STORAGE

If the caravan is to be stored for any length of time, especially over the winter period, the following operations are recommended.

Remove all linens, blankets, cushions, clothes, mattresses, etc. which could be affected by damp conditions. Clean the caravan inside and out as detailed in the previous section.

Drain off the water system. (See previous section).

Drain and sterilise the toilet. (See previous section).

Ensure all windows, roof lights and doors are correctly fastened and locked. Check fixed ventilation apertures are not obstructed.

Ensure that the alarm PIR's view of the caravan interior is clear and not obscured by items stored on the floor.

Check that the site you have chosen to store the caravan is open, fairly high and dry and if possible not exposed to gales etc. If this proves impossible it is recommended that the caravan chassis is anchored to the ground.

Jack up the caravan (use bottle or screw jack, do NOT use the corner steadies) so that the wheels are clear of the ground. Support the caravan axle with wooden blocks, axle stands or similar so that when the jacks are removed the wheels remain clear of the ground. Lower the corner steadies to 'just' site the caravan. Cover the tyres to prevent deterioration. Release the handbrake.

Rotate the wheels at regular intervals to maintain wheel-bearing lubrication. Grease the over-run and shroud in a waterproof protective cover. Grease must not be used if an AKS or similar stabiliser is fitted.

Switch off 12 volt supply.

SECURITY: Lowering and locking the corner steadies and removing the wheels reduces the risk of caravan theft.

NOTE: Do not work under the caravan unless the corner steadies are down and the axle is supported.

Should the caravan be stored for a prolonged period of time it is strongly recommended that the caravan is fully serviced before the commencement of use. Your dealer will ensure that your caravan is safe, secure and ready for your enjoyment.

NOTE: Caravans stored for any length of time should not have the handbrake applied. Ideally the wheels should be removed and the caravan placed on winter wheels and the handbrake released. The hitch head should be checked to see that it is fully extended and that there is no load on the braking system.

MAINTENANCE – AL-KO LIGHTWEIGHT CHASSIS

AL-KO GALVANISED CHASSIS

Hot dip galvanising offers high corrosion protection by forming a barrier layer through reaction with the atmosphere. This will be apparent by the chassis members changing to a light grey colour. During winter periods or storage where there is insufficient air circulation or heavy moisture, a soft porous, light grey oxidation layer may form. This is known as 'White Rust' and should NOT be confused with rust

THE AXLE (Fig 1)

The AL-KO rubber suspension axle has been designed for new standards of spring comfort and is maintenance free.

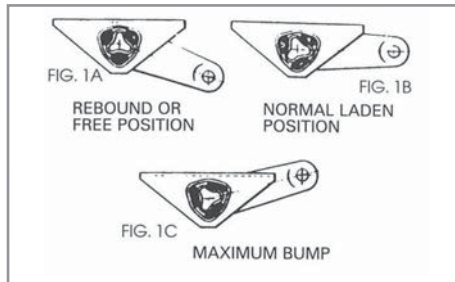

Three rubber elements are contained within a hexagonal axle tube. These provide suspension and have inherent damping characteristics.

Figures 1(A), (B) and (C) show the deformation of the rubber elements at the extremes of suspension movement.

The axle is designed to ride with the suspension drop arm at, or slightly below, the horizontal position.

SUSPENSION SHOCK ABSORBERS

All 2012 Coachman Caravans are fitted with AL-KO Octagon Shock Absorbers to provide increased damping characteristics and to improve road holding.

OPERATION OF BRAKING SYSTEM (Figs 2 and 3)

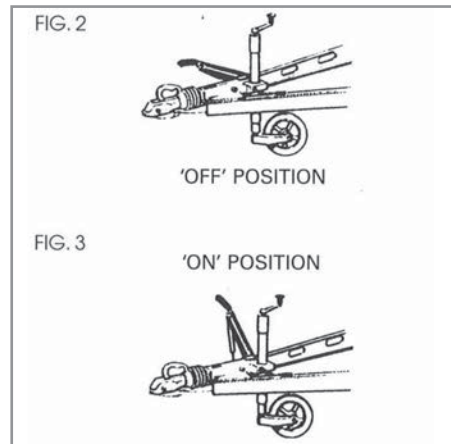

FORWARD BRAKING

In the free position, with the handbrake fully forward in the OFF position, the drawshaft of the overrun device is fully extended and the shoes are clear of the drum.

As the towing vehicle brakes, or starts to drive downhill, the drawshaft of the overrun device is depressed toward the unit being towed. This action imparts linear motion to the main shaft of the overrun device which is transmitted via the overrun lever, brake rod and Bowden cable to the expanding clutch. This mechanism forces the leading brake shoe and by reaction, the trailing shoe outwards into contact with the drum.

Friction between the brake shoes and the drum creates a tendency for both shoes and the expanding clutch to move in the direction of forward rotation until they abut the adjuster box. This ensures that both shoes remain in the braking position.

REVERSING

When the towing vehicle reverses, the drawshaft is pushed backward, moving the overrunning device through its full travel. This movement is transmitted in the normal manner to the expanding clutch.

The clutch forces both shoes into contact with the drum. Initial friction between these creates a tendency for the shoes and the

expanding clutch to move in the direction of the wheel rotation i.e. reverse. This movement imparts pressure to the spring-loaded auto-reverse lever, causing it to collapse. Thus, friction between the shoes and drum is almost eliminated, allowing the trailer to reverse in concert with the towing unit.

Slight forward movement of the chassis will allow the coiled spring to reassert itself, enabling the reverse lever to recover to its normal position. Normal braking is then immediately available

PARKING

The AL-KO parking brake system incorporates a patented device for added safety when parking on a reverse-sloping site or steep hill.

The AL-KO parking brake system comprises a handbrake lever mechanism actuating a Bowden cable, which operates a brake unit assembly, contained within the wheel hub.

AL-KO's unique parking brake system requires a source of stored energy to lock the wheel brakes should the trailer start to move after it has been uncoupled from the towing unit.

This energy source is provided by a spring cylinder acting as an energy store.

WHEELS AND TYRES

WHEELS

The AL-KO chassis is supported on road wheels fitted with pneumatic tyres. The size of wheel and type fitted to the chassis is dependent upon the load to be towed.

Each chassis is provided with an adjustable jockey wheel, which is clamped inboard directly to the overrun device. The jockey wheel provides stabilisation and is fitted with a solid tyre.

SPARE WHEEL CHASSIS MOUNTED

Each Coachman caravan has a unique AL-KO spare wheel carrier mounted on the chassis under the caravan.

The carrier is of extra strong, lightweight construction and is easy to operate. Detailed operating instructions are included under the heading "Changing a Wheel" on PAGE 23.

TYRES

Please refer to Technical Data Handbook for information regarding wheel and tyre sizes.

PRESSURES

It is customary for tyre manufacturers to mark tyres with load and inflation data. **This**

information relates to the use of the tyre on cars. This is not the operating or maximum pressure when used on a caravan.

Please refer to the technical supplement for information regarding tyre pressures.

It is dangerous to drive with under inflated tyres. The pressures (cold) recommended by the manufacturer should be adhered to.

Pressure checks, including those on the spare tyre, should be made with the tyres cold and using an accurate pressure gauge. The checks should be carried out before each journey and at regular intervals during storage.

TYRE WEAR AND DAMAGE

The legal requirements for tread depth on motor vehicles' tyres applies also to caravans. Similarly, it is not permitted to mix cross-ply and radial tyres on the same axle. A redundant tyre must be replaced by one of the same size and construction.

Wheels should be balanced and changed round occasionally to equal wear and prolong the life of the tyres. A tyre should be renewed if a blister, rupture or cut exposing the casing is detected. If the tyre has suffered violent impact (e.g. against a kerb), it should be examined by a specialist as soon as possible.

MAINTENANCE – AL-KO LIGHTWEIGHT CHASSIS

As from April 1987 the speed limit in the UK when towing a caravan was raised from 50mph to 60mph where permitted.

RECOMMENDED LUBRICANTS

Mobilgrease MP is recommended for all greasing routines. A good all-purpose oil is recommended for general use.

AL-KO EURO-AXLE

DESCRIPTION

Retaining the well-proven AL-KO Hexagonal rubber independent suspension, the specific features of the AL-KO Euro-Axle are:

- Bolted on wheel brakes
- Adjustable toe-in and camber (factory only)
- Strengthened stub axle. Sealed for life bearing unit
- Octagon Shock Absorbers

In addition the backplate has a 'gold' coloured, zinc passivated finish.

All Euro-Axles can be positively identified by the axle date plate.

IMPORTANT NOTE

The toe-in and camber is factory set and must not be altered.

Braking System adjustment must be carried out by an Approved Dealer.

AL-KO BRAKING SYSTEM ADJUSTMENT

This must only be undertaken by an Approved Dealer.

CHANGING A WHEEL

The corner steadies must not be used to jack up the caravan. They can be lowered to touch the ground only as a safety measure to stabilise the caravan.

(b) Apply the handbrake full as for parking.

Do not forget to give the caravan or trailer a slight rearward push to stop

the reversing lever collapsing.

(c) Slacken off the wheel bolts on the wheel to be changed.

(d) Jack up the caravan with the jack under either the axle tube or the axle mounting plate.

Do not use the chassis member as a jacking point.

If there is lack of ground clearance because of a flat tyre, gently move the caravan onto some ramping boards.

(e) Support the weight of the caravan on axle stands or ramping boards. Lower the corner steadies.

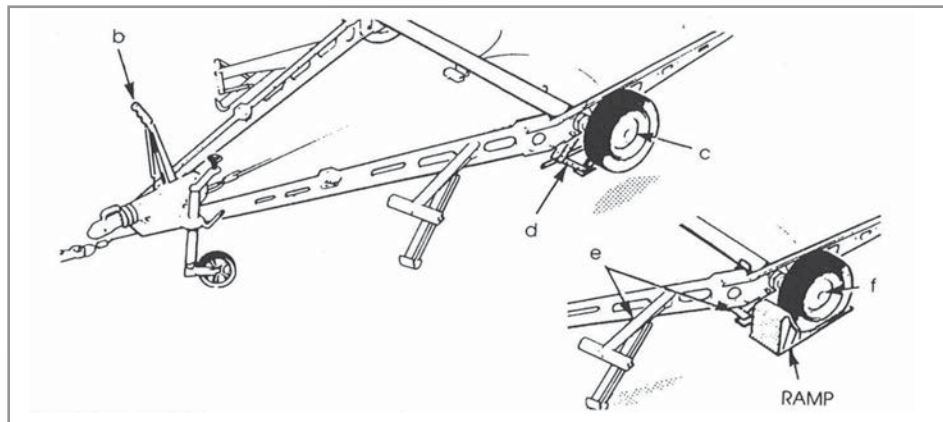

- (f) Remove the wheel bolts and remove the redundant wheel.

The spare wheel is located in the AL-KO spare wheel carrier situated just behind the axle. To remove it follow the instructions on Page 23 (Items 5 to 7).

Before fitting a new wheel, examine it for distortion or other damage. Ensure that all mating surfaces are clean and dry, including bolt seats.

ALWAYS USE THE CORRECT BOLTS TO SECURE THE WHEEL. THERE ARE UNIQUE BOLTS FOR ALLOY WHEELS AND UNDER NO CIRCUMSTANCES SHOULD ANY OTHER BOLTS BE USED WITH ALLOY WHEELS. Alloy wheel bolts are stamped with 10.9 and may be used with steel wheels.

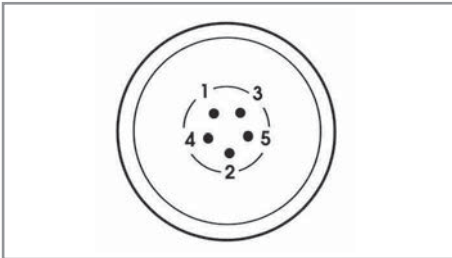

A corner steady brace is not to be used for the next step.

- Fit the new wheel and refit the wheel bolts.

WARNING – Ensure the wheel is of the same construction and size with the one that has been removed

Tighten all bolts equally in the order shown in the diagram.

Torque settings are:

Steel Wheels	88Nm (65lbsft)
Alloy Wheels	130Nm (96lbsft)

Please note with alloy wheels you should first tighten all the bolts to 85Nm (63lbsft) then go round again in the sequence shown and increase the torque from 85Nm (63kbsft) to 130Nm (96lbsft).

- Raise the corner steadies. Take the weight of the caravan onto the jack and remove the axle stands or ramping boards.
- Lower the caravan to the ground.

WARNING:

- 1. After the first 30 miles check all road wheel bolts and tighten, if required, to correct torque setting.**
- 2. Check wheel bolt torque before each major journey.**
- 3. Never use grease of any kind on wheel bolts.**

JACKING

Under no circumstances should the corner steadies be used to jack up the unit.

When it is necessary to jack up use the jack supplied on VIP and Laser, or use a bottle, screw or scissor type jack with axle shaped head is recommended. Place the jack plate under the axle tube as near as possible to the main chassis member.

LUBRICATION

Lubricate the Jockey Wheel

Lightly oil the wheel axle and screw thread.

Lubricate the Brake Linkage

Lightly oil all moving parts.

Lubricate the Corner Steadies

Lightly oil the screw and pivot pins.

For more information concerning the chassis and undergear please refer to the AL-KO handbook contained within your document wallet.

SERVICING

It is a condition of warranty that your caravan is serviced once a year by a competent Service Centre. Proof of this will be required in the event of a warranty claim.

The Coachman warranty does require that servicing must be carried out within 90 days either side of the anniversary of the purchase date for interim years but before the anniversary date on the final year and must include a full damp check

Your caravan also requires servicing at least once a year for safety, efficiency and to protect the investment you have made. Whether the caravan is used for short trips or continental long range touring, regular servicing is necessary and will ensure continued enjoyment of your caravan.

Dealers will carry out your annual servicing using the latest techniques and equipment (a list of the items to be inspected, tested and adjusted appears in your Warranty and Service Handbook and at the rear of this guide), and will complete the service document as proof of regular maintenance.

As with motor vehicle service documents, not only will the proof of regular servicing enhance your caravan's resale value but in the unlikely event of any defect appearing at some later date it is vital that service history can be identified.

We suggest service invoices are retained with this guide.

Additionally, but most importantly, regular service is a requisite of the Guarantee and will preserve your rights under the warranty.

PARTS

In the interest of safety, replacement parts for an appliance shall conform to the appliance manufacturers' specification and should be fitted by him, or his authorised agent.

MAINS ELECTRICS

It is recommended that you have your Mains Electric's System inspected by an NICEIC approved contractor every 3 years.

CUSTOMER SERVICES

Should you require any replacement parts for your caravan it is necessary that you contact the dealer from whom you purchased the caravan or any authorised dealer and give the following information, which will help in identifying the required component.

- a) Model of caravan.
- b) VIN number.
- c) Description of fault plus sizes if cupboard doors, mirrors, windows wheels & tyres etc. are required.

ALL PARTS MUST BE ORDERED AND SUPPLIED THROUGH YOUR APPOINTED DEALER.

The dealer can then order them from the factory or direct from the supplier for appliances detailed overleaf where the original supplier undertakes warranty.

All the illustrations and descriptive matter in this guide are intended to give a general idea of the caravan. Changing market and supply situations may prevent the manufacturer from maintaining the exact specifications and details in this handbook and we therefore reserve the right to alter specifications and materials as conditions demand.

Dealers are not agents of the manufacturer and have absolutely no authority to bind the manufacturers by any express or implied undertaking or representation.

REPAIRS

Should you be unfortunate enough to suffer an accident with your caravan, you should contact your Dealer.

The cost of transporting, towing or moving the caravan by any means to or from the place of repair is the responsibility of the owner.

The manufacturers will also undertake to

supply certain specialist repairs with the necessary spare parts. In this case, your selected repairer must contact the AFTER SALES DEPARTMENT with all enquiries.

Coachman genuine parts and recommended procedures must be used at all times.

SERVICE DOCUMENTS

TOURING CARAVANS – ANNUAL SERVICE RECORD

Your caravan needs servicing at least once a year.

Whether you use your caravan for short journeys or for touring at home or abroad, regular servicing will help ensure that you can enjoy it to the full.

The Annual Service offered by your Dealer will include the following work and it is our recommendation you have your caravan serviced to this standard annually.

The dealer will complete the record in this guide to show the work has been carried out.

SECTION (A) CHASSIS

1. Brakes/Lights
2. Suspension
3. Axles and Hubs
4. Tyres and pressures
5. Wheel bolts
6. Towing hitch and overrun device
7. Jockey wheel
8. Breakaway cable
9. Corner steadies
10. Check wheel carrier and grease sliding joints.
11. Lubrication
12. Operational check

SECTION (B) EXTERIOR

1. Exterior panels
2. Windows
3. Rooflights
4. Entrance door/Door Locks
5. Wheel boxes
6. Mouldings
7. Gas bottle and locker

8. Ventilation
9. Paintwork
10. All seals, mouldings etc.
11. Reflectors
12. Graphics

SECTION (C) INTERIOR

1. Wall panels
2. Furniture
3. Curtains/Blinds/Flyscreens
4. Bedding/seating
5. Carpet
6. Door and Drawers
7. All hinges and catches
8. Ventilation
9. Hoses and sink plugs
10. Hot water system
11. Cold water system
12. Window hinges and stays
13. Cassette Toilet
14. Shower
15. Shower Tray
16. Central Heating
17. Damp test

SERVICING

SECTION (D) ELECTRICAL

1. All interior lights/Road lights
2. Water pump and switches
3. Refrigerator
4. Distribution Unit
5. Charging Unit
6. Junction box
7. Wiring and supports
8. Trailer connecting plugs
9. Overall tests ext. lights
10. Awning light
11. Electronic Ignition (Hob)
12. 12v/230v System where applicable

SECTION (E) GAS INSTALLATION

1. Hob burners
2. Oven
3. Heater
5. Fridge
6. Water heating
7. Fully operational
8. Leak tested

SECTION (F) FINAL

Road Test

CARE WARRANTY

Your caravan is covered by a 5 year warranty. To activate this warranty your selling dealer must forward the signed and completed Registration Form contained in the Warranty and Service Handbook within one week of purchase. It is a condition of this warranty that a service and safety check is carried out by your caravan dealer at least once every year (12 months from the date of purchase), within the period 90 days before to 90 days after the anniversary of the purchase date for interim years but BEFORE THE ANNIVERSARY ON THE FINAL YEAR in accordance with the National Caravan Council recommendations. For further information please read your policy documents in your Warranty and Service Handbook.

IF YOU HAVE A “WARRANTY” PROBLEM

We sincerely hope you will never have cause to complain about your caravan. However, if things do go wrong, the course of action for you is to contact your dealer and explain the difficulty you are having. We are confident they will do their utmost to resolve the problem to your complete satisfaction.

The Dealer from whom the caravan is purchased is liable for warranty repairs.

Any other approved dealers may carry out work on a caravan at his own convenience or discretion, but is not obliged to do this.

Your caravan is supplied to you with a manufacturers warranty guarantee that is valid for 5 years from the date of purchase except when otherwise stated.

Please refer to your Extended Warranty and Service Handbook for details.

The manufacturers are not responsible for travelling costs incurred returning a caravan to a dealer or the factory for warranty repair. This also applies to consequential loss, i.e. earnings incurred.

You will need to retain proof of servicing (invoices) in the event of a warranty claim.

SPECIFIC EXCLUSIONS

During the first year; tyres, bulbs, fluorescent tubes and fuses. Normal wear and tear.

- Proprietary products such as refrigerators, space heater, water heaters, ovens and audio equipment which are covered by the respective manufacturers’ own guarantee and service arrangements. (See list on Page 104)
- The caravan is not covered if the manufacturers’ identification (vehicle identification number) of the caravan has

been defaced or removed.

The warranty also excludes

- Failure due to reasons of fair wear and tear.
- Damage resulting from accidents.
- Misuse of any component.
- Replacement of parts which have reached the end of their effective working life because of age and/or usage.
- Cleaning or adjustment of any assemblies.

The warranty will be invalidated if the caravan has been neglected, misused or modified in any way without the prior agreement of Coachman Caravans.

The warranty also excludes.

- Caravans used for hire or reward.
- Caravans used for other than recreational purposes i.e. for living in or business purposes.
- The cost of transporting the caravan, by whatever means, to the place of repair.
- Any consequential cost or loss arising.
- Damage by mould.
- Damage by forces of nature.
- Damage by vermin.

WARRANTY

For full details of the warranty refer to your Warranty and Service Handbook.

In years two, three, four and five, the Warranty will cover all original components of the caravan including permanently fitted equipment forming part of the original manufacturer's specification plus water ingress and delamination. The specific exclusions of the Coachman Caravan Company Limited Warranty during years two, three, four and five are tyres, battery, glass, paintwork, brightwork and all similar trim and finish, tables, hinges, knobs and handles, window catches, stays and associated fittings, adjustment of blinds, catches, stays and doors, replacement of bulbs, fluorescent tubes and electrical connection, entertainment/communications systems and connected equipment. Additionally proprietary products such as refrigerators, space heaters, water heaters, ovens, chassis and audio equipment which are covered by the respective manufacturers' own guarantee and service arrangement are also excluded. (SEE LIST PAGE 104)

- The caravan is not covered if the manufacturers' identification (vehicle identification number) of the caravan has been defaced or removed.

The warranty also excludes

- Failure due to reasons of fair wear and tear.
- Damage resulting from accidents.
- Misuse of any component.
- Replacement of parts which have reached the end of their effective working life because of age and/or usage.
- Cleaning or adjustment of any assemblies.

The warranty will be invalidated if the caravan has been neglected, misused or modified in any way without the prior agreement of Coachman Caravans. The caravan will be deemed to have been neglected if it has not been serviced and maintained as stated in the Warranty and Service Handbook.

The warranty also excludes.

- Caravans used for hire or reward.
- Caravans used for other than recreational purposed i.e. for living in or business purposes.
- The cost of transporting the caravan, by whatever means, to the place of repair.
- Any consequential cost or loss arising.

- Damage by mould.
- Damage by forces of nature.

For full details of the warranty refer to your Warranty and Service Handbook.

The remaining benefits of the Coachman Five Year Warranty may be transferred to a new owner if the caravan is sold provided the caravan has been serviced by an Authorised Dealer in accordance with the requirements of the Warranty and Service Handbook and details of the change of ownership have been supplied to Coachman using the change of ownership form in the

IT IS A CONDITION OF YOUR WARRANTY THAT YOUR CARAVAN IS SERVICED ANNUALLY BY AN APPROVED COACHMAN DEALER OR A COMPETENT SERVICE CENTRE.

Warranty and Service Handbook.

WATER INGRESS

We at Coachman recognise that while over recent years we, together with our sealant suppliers, have made tremendous developments in sealants and sealing techniques and are extremely confident in our product resisting water ingress, it is water ingress above all other problems

which remains the main worry and concern of potential and actual retail customers.

Therefore, on every new Coachman caravan sold, we make a comprehensive 6 year Worry Free Water Ingress and Delamination Offer:

- Water Ingress between new and 5 years – All labour and parts covered by the Coachman Warranty provided there is a full service history.
- Water Ingress between 5 and 6 years:
- Coachman will pay the total labour cost and supply parts free of charge provided there is a full service history and the fifth service was carried out before the anniversary date on the final year of the five year warranty.
- When a customer part exchanges a Coachman caravan at a Coachman Dealer and water ingress is detected at the time of the part exchange Coachman confirms they will pay the dealer the total of the agreed cost of any repair undertaken to rectify the water ingress provided:
 1. It is being exchanged for a new Coachman Caravan.
 2. There is full documentary evidence that the caravan has been serviced annually.
 3. The caravan is less than 6 years old.

WARRANTY & AFTER-SALES REFERENCE CHART

EQUIPMENT MANUFACTURERS HANDLING WARRANTY DIRECT WITH DEALERS		
Appliance/Component	Company & Address	Telephone Numbers
AL-KO Chassis, axle & undergear Hitch, Traction Control	AL-KO Chassis, axle & undergear Hitch, Traction Control	01926 818500
CD/Radio/DVD/MP3	Base Systems Limited, 85/87 Fylde Road, Preston, PR1 2XQ	0800 0264343
Alarm	Sargent Electrical Systems Ltd, Unit 39 Tokenspire Business Park, Woodmansey, Beverley, HU17 0TB	01482 678981
Polyplastic Windows	Miriad Products Limited, 2000 Park Lane, Dove Valley Park, Foston, South Derbyshire, DE65 5BG	01283 586060
Porta Potti Cassette Toilet	Thetford Limited, Unit 6, Brookfields Way, Manvers, Rotherham, S63 5DL	0844 9971960
Power Centre/Chargers/Loom/Relays Consumer Unit/Control Panels.	BCA Leisure Ltd, Unit H9 Premier Way, Lowfields Business Park, Elland, HX5 9HF	01422 376977
Cooker Hob and Refrigerator	Thetford Limited, Unit 6, Brookfields Way, Manvers, Rotherham, S63 5DL	0844 9971960
Shower Towers	Plas-Tech Thermoforming, Catfoss Ind Estate, Catfoss Lane, Brandesburton, Driffield, YO25 8EU	01964 544544
Soft Furnishings	Leisure Furnishings Ltd, Unit 4, Meadow Brooks Business Park, Meadow Lane, Long Eaton, Notts, NG10 2GD	01159 463666
Status Aerial	Grade UK, 8 Finch Close, Lenton Lane Industrial Estate, Nottingham, NG7 2NN	01159 867151
Ultra Heat Space Heater/Ultrastore Water Heater/Regulator/Ultraflow Filter Housing/Compact Housing	Truma UK Limited, Park Lane, Dove Valley Park, Foston, South Derbyshire, DE65 5BG	01283 586050
Phantom Tracker	Phantom Limited, 149 Broadstone Road, Stockport, Cheshire, SK5 7GA	0870 7777060
Whale OnBoard Water Tank	Munster Simms, Old Belfast Road, Bangor, County Down, Northern Ireland, BT19 1LT	02891 270531
Alde Heating	Alde, 14 Regent Park, Booth Drive, Hark Farm South Ind. Est, Wellingborough, NN8 6AB	01933 677765
Smoke and Carbon Monoxide Alarms	FireAngel, The Techno Centre, Puma Way, Coventry, CV1 2TT	0800 1412561
Omnivent	Rose and Co, Westmoreland Street, Hull, HU2 0HS	01482 328231

A		Connecting Services	28	Wheels & Tyres	95	T	
Alarm	86	Water	28	Microwave	66	Television & FM Radio Aerial	83
AL-KO Lightweight Chassis	94	Gas	34	O		Thetford Cassette Toilet	73
Arrival at Site	27	Electricity	38	Oven, Hob, Grill	60	Towing Code	8
Parking	28	Consumer Unit	40	P		Towing & Driving	22
Selecting a Pitch	27	Control Panel	43	Preparing for the Road	11	Pulling Off	22
Unhitching	27	Coupling-Up Checklist	21	Pre-Tow Checklist & Hitch-up	13	Reversing	22
Levelling	28	E		Pressure Switch	31	Speed Limits	22
B		Electricity	38	R		U	
Battery	42	Wiring of Connecting Cable & Caravan Mains Inlet	39	Refrigerator	53	Ultraflow Filter Housing	29
Beds & Bunks	88	Fuses	40	Rooflights	76	V	
Blinds & Flyscreens	82	Relay Housing	41	The Heki 2 Rooflights	78	Ventilation	24
Body Shell	6	Testing R.C.D.	41	The Omnivent 12V Rooflight	77	V.I.N	5
Braking System	6	Polarity	42	The Mini Heki Rooflight	79	W	
Brake-Away Cable	20	12v System	40	The Midi Heki Rooflight	81	Warranty	12
C		Entertainment System	82	S		Water Heater (Combi)	46
Caravan Equipment	46	G		Safety & Security	24	Electrical Operating	47
Caravan Handling	22	Gas	34	Security Tag	5	Instructions	47
Caravan Mains Inlet	39	The Regulator	34	Servicing	98	Gas Operating Instructions	47
Caravan Registration & Identification Scheme (VIN)	5	Types of Gas	34	Heater	46	Water Pump	29
Charger	41	Gas Barbecue Point	36	Speed Limits	22	Water System	29
Cleaning	89	M		Smoke Alarm	67	Wheel Changing	23
		Maintenance		Stabiliser	17	Waste Connection	28
		Wheel Changing	23	Storage	93		

the journey starts here..



Coachman Caravan Company
Aftercare Operatons
Amsterdam Road
Sutton Fields Industrial Estate
Hull HU7 0XF
Tel: 01482 877405 Fax: 01482 371679

www.coachman.co.uk