

# ***BIRO***®

## **HEAVY HORSEPOWER GRINDER OPERATING MANUAL & PARTS LIST**

Models 342, 542, 548, 552, 7542, 7548, 7552, 1056, 1556  
Applicable on HHP Grinders starting with Serial No. 2250



*Biro Designed*

*Biro Built*



### **IMPORTANT NOTICE**



This Manual contains important safety instructions which must be strictly followed when using this equipment.

PTCT  
H400-078A  
8-08-23

# TABLE OF CONTENTS

	Page
NOTICE TO OWNERS AND OPERATORS .....	1
SAFETY TIPS .....	2
INSTALLATION .....	3
UNCRATING AND SET UP .....	3
MOTOR WIRING .....	3
ELECTRICAL REQUIREMENTS .....	4
MOTOR SPECIFICATIONS .....	4
WIRING DIAGRAMS .....	5
OPERATION .....	6
TO PROCESS PRODUCT .....	6
CLEANING .....	7
MAINTENANCE .....	8
GRINDING BOWL INSTALLATION .....	8
BEARING HOUSING LUBRICATION .....	9
ROLLER CHAIN AND DRIVE SPROCKET LUBRICATION .....	9
MAIN DRIVE CHAIN TENSION .....	9
PARTS DIAGRAMS, MAIN BODY AND DRIVE SYSTEM FOR 3, 5, 7½ HORSEPOWER GRINDERS .....	10
AND WARNING LABELS & LOCATIONS ON GRINDERS	
PARTS DIAGRAMS, BOWL AND TRAY SECTION FOR 3, 5, 7½ HORSEPOWER GRINDERS .....	11
AND WARNING LABELS & LOCATIONS ON GRINDERS	
ELECTRICAL CONTROLS FOR 3, 5, 7½ HORSEPOWER GRINDERS .....	12 & 13
PARTS DIAGRAMS, MAIN BODY AND DRIVE SYSTEM FOR 10 & 15 HORSEPOWER GRINDERS .....	14
AND WARNING LABELS & LOCATIONS ON GRINDERS	
PARTS DIAGRAMS, BOWL AND TRAY SECTION FOR 10 & 15 HORSEPOWER GRINDERS .....	15
AND WARNING LABELS & LOCATIONS ON GRINDERS	
ELECTRICAL CONTROLS FOR 10 & 15 HORSEPOWER GRINDERS .....	16
OPERATOR'S SIGNATURE PAGE .....	17
LIMITED WARRANTY .....	18

## NOTICE TO OWNERS AND OPERATORS

BIRO's products are designed to process food products safely and efficiently. Unless the operator is properly trained and supervised, however, there is the possibility of a serious injury. It is the responsibility of the owner to assure that this machine is used properly and safely, strictly following the instructions contained in this Manual and any requirements of local law.

No one should use or service this machine without proper training and supervision. All operators should be thoroughly familiar with the procedures contained in this Manual. Even so BIRO cannot anticipate every circumstance or environment in which its products will be used. You, the owner and operator, must remain alert to the hazards posed by the function of this equipment – particularly the ROTATING GRINDING WORM, which can severely injure an inattentive operator amputating fingers and limbs. No one under eighteen (18) years of age should operate this equipment. If you are uncertain about a particular task, ask your supervisor.

This Manual contains a number of safe practices in the SAFETY TIP section. Additional warnings are placed throughout the Manual. Warnings related to your personal safety are indicated by:



OR



Warnings related to possible damage are indicated by:



BIRO also has provided warning labels on the equipment. If any warning label or Manual becomes misplaced, damaged, or illegible, please contact your nearest Distributor or BIRO directly for a replacement.

Remember, however, this Manual or the warning labels do not replace the need to be alert and to use your common sense when using this equipment.

This Manual applies to machines with serial number 2250 and higher.

**- NOTE -**

**A copy of this manual is included with each HEAVY HORSEPOWER GRINDER.**

**The descriptions and illustrations contained in this manual are not binding.  
The manufacturer reserves the right to introduce any modification  
without updating the manual.**

## SAFETY TIPS

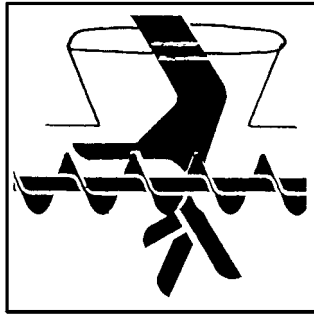

### **ROTATING GRINDING WORM TO AVOID SERIOUS PERSONAL INJURY**

**NEVER** Touch This Machine Without Training and Authorization By Your Supervisor.

**ALWAYS** Read Operation and Service Manual **BEFORE** Operating, Cleaning or Servicing.

**NEVER** Place Hands Into Machine Input or Output Openings.

**NEVER** Open Machine During Operation.

**ONLY** Use a Qualified Electrician to Install According to Local Building Codes: Machine **MUST** Be Properly Grounded.

**ALWAYS** Connect to **Proper** Voltage & Phase.

**ONLY** Install on Level, Non-Skid Surface in a Clean, Well-Lighted Work Area Away From Children and Visitors.

**NEVER** Use This Machine For Non-Food Products.

**NEVER** Operate Machine With Tray And/Or Tray Guard Removed, or Magnetic Safety Switch By-Passed.

**ALWAYS** Turn Off, Unplug From Power Source and Perform Lockout/Tagout Procedure to This Machine **BEFORE** Attempting to Unjam or Unclog, Cleaning or Servicing.

**NEVER** Leave Machine Unattended While Operating.

**NEVER** Alter This Machine From its Original Form as Shipped From Factory. **DO NOT** Operate Machine With Parts Missing.

**PROMPTLY REPLACE** Any Worn or Illegible Warning Labels.

**USE ONLY BIRO** Parts and Accessories Properly Installed.

# INSTALLATION



## TO AVOID SERIOUS PERSONAL INJURY PROPERLY INSTALL EQUIPMENT IN ADEQUATE WORK AREA

***ALWAYS** Use Qualified Technician and Electrician for Installation.*

***ALWAYS** Connect to **Proper** Voltage & Phase.*

***ALWAYS** Install Equipment in Work Area with Adequate Light and Space Away From Children and Visitors.*

***ONLY** Operate on a Solid, Level, Non-Skid Surface.*

***NEVER** Bypass, Alter, or Modify This Equipment in Any Way From Its Original Condition.*

***NEVER** Operate With Tray And/Or Tray Guard Removed, or Magnetic Safety Switch By-Passed.*

***NEVER** Operate Without all Warning Labels Attached and Owner/Operator Manual Available to the Operator.*

## UNCRATING AND SET UP

1. Read this Manual thoroughly before installation and operation. **Do not** proceed with installation and operation if you have any questions or do not understand anything in this Manual. Contact your local Distributor, or BIRO first.
2. Install machine on a level, solid, non-skid surface in a well-lighted work area away from children and visitors.



### **ALWAYS LEVEL MACHINE BEFORE USING**

3. After installing machine in operational area, it is imperative that the four adjusting legs be adjusted to level the machine and also eliminate rocking.
4. This machine is complete except for a knife and plate. There is a bowl shipping plug (stamped steel) placed in the output end of the grinding bowl to retain the grinding worm during shipment. **REMOVE THE BOWL SHIPPING PLUG AND THE GRINDING WORM.**



5. After checking and making sure the power supply is correct, plug in your machine. **NEVER OPERATE MACHINE WITHOUT TRAY AND GUARD INSTALLED** (Machine will not run with tray removed).
6. Machine must be properly grounded. Use qualified electrician to install according to building codes.

### **MOTOR WIRING AND ELECTRICAL REQUIREMENTS**

- (A) Interchange of current is made in motor outlet box. Leads are properly marked. Changing instructions are on the motor plate or motor outlet box.
- (B) All grinders are wired 220 volts unless otherwise specified. Be sure motor specifications (voltage, cycle, phase) match power supply line. Be sure line voltage is up to specification.
- (C) Electrical connections to be accordance with safety codes and National Electrical Code.

- (D) Rated voltage of the unit shall be identical with full supply voltage.
- (E) Voltage drop on the supply line shall not exceed 10% of full supply voltage.
- (F) The feederline conductor size in the raceway from the branch circuit to the unit must be correct to assure adequate voltage under heavy starting and short overload conditions.
- (G) The feederline conductor shall only be used for the supply of one unit of the relevant horsepower. For connections of more than one unit on the same feederline, a local electrician will have to be consulted to determine the proper conductor size.
- (H) The size of the electrical wiring required from the power source to the grinder on the 3, 5, 7½ HP Grinders is a **MINIMUM OF No. 10 WIRE**. On the 10 & 15 HP Grinders a **MINIMUM OF No. 8 and No. 6** respectively.
- (I) The BIRO Manufacturing Company is not responsible for permanent wiring, connection or installation.



**NOTE TO OWNER AND ELECTRICIAN: IF THIS MACHINE IS NOT CORD AND PLUG CONNECTED TO THE ELECTRICAL SUPPLY SOURCE, THEN IT SHOULD BE EQUIPPED WITH, OR CONNECTED TO, A LOCKABLE, MANUALLY-OPERATED DISCONNECT SWITCH (OSHA 1010.147).**

**MOTOR SPECIFICATIONS**

HP	KW	VOLTS	HZ	PH	AMPS
5	4	208/220	60	3	17/16
5	4	230	60	1	27
5	4	440	60	3	8
5	4	550	60	3	6.4
7.5	5.5	208/220	60	3	23/22
7.5	5.5	440	60	3	11
10	7.5	208/220	60	3	27/25.6
10	7.5	440	60	3	12.8
10	7.5	550	60	3	10
15	11	208/220	60	3	41/39
15	11	440	60	3	19.5

- 7. Located on the side of the machine is a toggle handle that activates the internal on/off switch. The interlock safety switch is mounted to the top of the internal switch and will break contact with the magnetic starter should the tray be removed.



- 8. Turn the toggle handle to the "ON" position. **CHECK THE ROTATION OF THE WORM DRIVE SHAFT; ROTATION MUST BE COUNTER-CLOCKWISE** as indicated by the rotation decal affixed to the grinding bowl. **ROTATION MUST ONLY BE CHECKED WITH THE GRINDING WORM REMOVED**, otherwise serious irreparable damage may occur to grinding components.
- 9. If machine runs clockwise (backwards), it must be rewired to correct rotation, otherwise serious irreparable damage may occur to grinding components.
- 10. Insert worm assembly into grinding bowl, place knife (sharp edges out) onto the square end of the worm assembly. The breaker plate slides over the worm knife drive pin, and is held from rotating by pins in the grinding bowl. Put on the retaining ring.



**ONLY HAND TIGHTEN RETAINING RING**

For best results, use knife and plate as a set. **Do not operate machine for any period of time** without product in the grinding bowl. This will cause heating and dulling of the knife and plate.

- 11. Check placement of all warning labels and Manual. Machine is now ready for trained operators to process product.
- 12. Use meat deflector attached to tray to eliminate meat splatter.
- 13. Contact your local Distributor or BIRO directly if you have any questions or problems with the installation or operation of this machine.

**WIRING DIAGRAM FOR HEAVY HORSEPOWER MANUAL FEED GRINDERS  
EQUIPPED WITH AEG OR STROMBERG STARTER (3, 5, 7½ HP ONLY)  
STARTING WITH SERIAL NUMBER 24808**

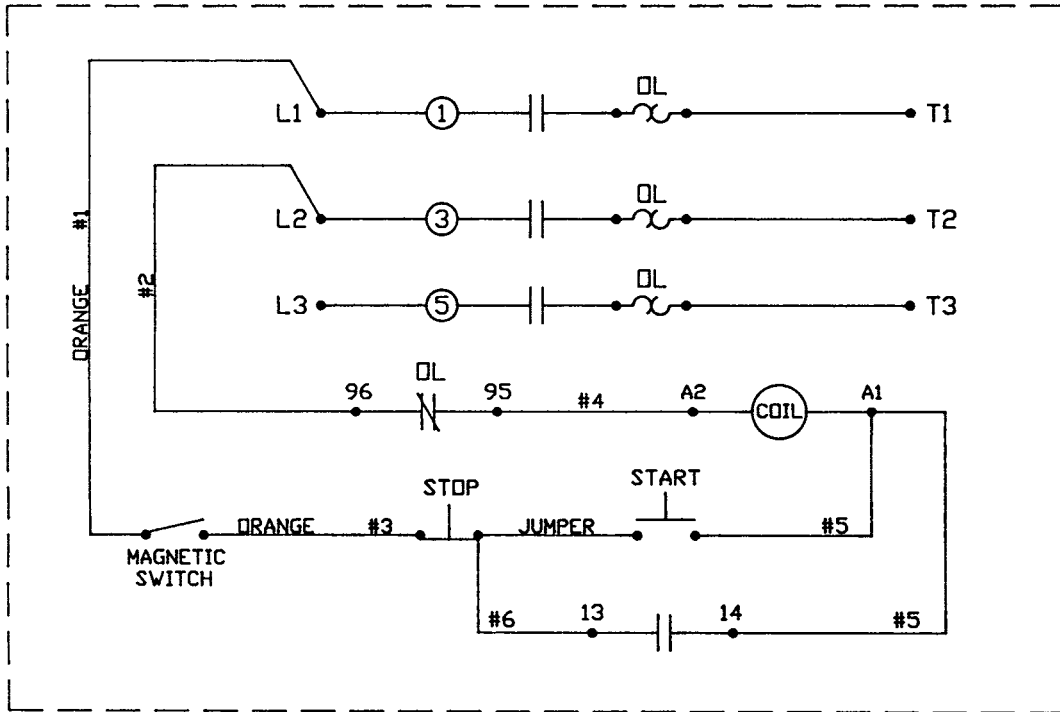

**WIRING DIAGRAM FOR HEAVY HORSEPOWER MANUAL FEED GRINDERS  
EQUIPPED WITH AEG OR STROMBERG STARTER (10,15 HP ONLY)**

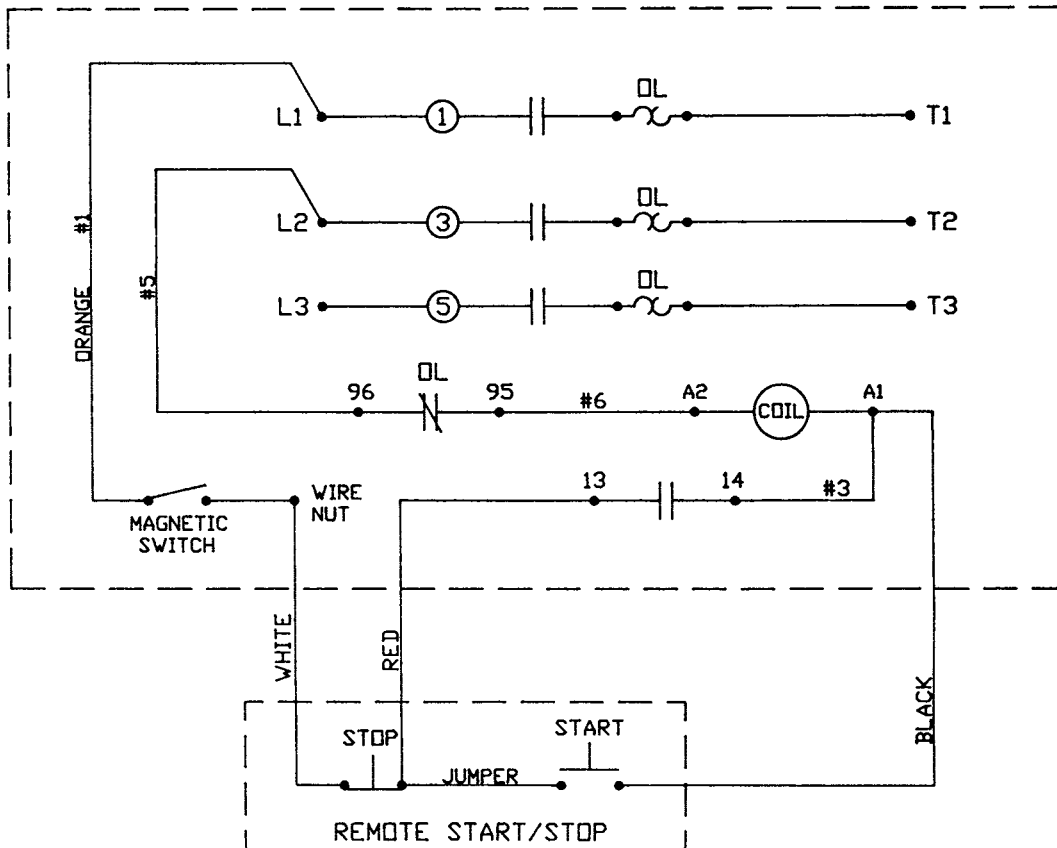

# OPERATION



## **ROTATING GRINDING WORM TO AVOID SERIOUS PERSONAL INJURY**

***ONLY** Properly Trained Personnel Should Use This Equipment.*

***NEVER** Place Hands Into Machine Input or Output Openings.*

***NEVER** Open Machine During Operation.*

***DO NOT** Wear Gloves While Operating.*

***DO NOT** Tamper With, Bypass, Alter, or Modify This Equipment in Any Way From Its Original Condition.*

***NEVER** Operate Machine With Tray And/Or Guard Removed, or Magnetic Safety Switch By-Passed.*

***ALWAYS** Turn Off, Unplug From Power Source and Perform Lockout/Tagout Procedure to This Machine Before Unjamming, Unclogging, Cleaning or Servicing.*

***NEVER** Leave Unattended While Operating.*

***NEVER** Operate Without All Warning Labels Attached and Owner/Operator Manual Available to the Operator.*

### **A. TO PROCESS PRODUCT**

1. Before starting grinder, have meat stomper within easy reach and method of receiving ground product located at output end of grinding bowl.
2. Turn toggle to "ON" position. Look down grinder bowl and make certain grinding worm is turning in the proper direction (counter-clockwise).
3. Carefully push unground product to top opening of grinding bowl and let drop to grinding worm. Product will then be ground out.



### **DO NOT REACH DOWN BOWL OPENING**

4. Use meat stomper to assist any product that should "bridge up" in grinding bowl opening.
5. When finished grinding turn toggle handle to "OFF" position and unplug grinder from power source and perform lockout/tagout procedure.

#### **DO'S**

- Always keep knife & plate as matched set.
- Always keep the knife & plate sharp.
- Always check for levelness by laying the knife on the plate before inserting in machine.
- Always install the knife & plate in correct sequence, knife 1st then plate.
- Always keep knives & plates lubricated in storage and when starting up machine.
- Always use coolant when sharpening plates.
- Always inspect the plates making sure all holes are clear that there are no cracks.

#### **DON'Ts**

- Never, never mix different knives to different plates.
- Never, never over tighten the bowl retaining ring on the machine.
- Never, never run the grinder/mincer without product. Product is a natural lubricant. Heat can build up so fast that cold product could crack the plate.
- Never, never hit the plate against anything to clean the holes.
- Never, never throw the knives & plates.



## CLEANING



### **ROTATING GRINDING WORM TO AVOID SERIOUS PERSONAL INJURY**

**ALWAYS** Turn Off, Unplug From Power Source and Perform Lockout/Tagout Procedure to This Machine **BEFORE** Cleaning or Servicing.

**ONLY** Use Recommended Cleaning Equipment, Materials and Procedures.

**NEVER** Spray Water or Other Liquid Substances Directly at Motor, Power Switch or any Other Electrical Components.

**ALWAYS** Thoroughly Clean Equipment at Least Daily.

#### **CLEANING THE BIRO HEAVY HORSEPOWER GRINDER**

1. Disconnect grinder from power source and perform lockout/tagout procedures.
2. Remove grinding bowl, end ring, breaker plate, knife and grinding worm.



#### **DO NOT SPRAY DIRECTLY AT ELECTRICAL COMPONENTS**

3. Machine is now ready to be cleaned using warm soapy water and rinsed with clean water. Machine may be cleaned by power spray washing, taking care to not spray directly at any electrical controls.
4. The grinding bowl can be removed for cleaning if desired. This is accomplished by removing the two nuts on the back flange of the grinding bowl.
5. After machine has been cleaned and allowed to air dry, all exposed metal surfaces should be coated with a good food grade light oil or grease.

#### **CLEANING THE BOWL - RING AND WORM CARE OF TIN COATED PRODUCTS (DO'S AND DON'TS)**

1. Do not use abrasive cleaning materials, such as Brillo pads or metal scrapers. Tin is a soft metal and should be cleaned with a soft cloth and dried.
2. Do not use a cleaning agent containing a high percentage of free alkali or acid.
3. Do not use detergent containing a high percentage of tri-sodium phosphate or meta-silicate. Tin is reactive to both.
4. Rinse well and dry thoroughly after washing to remove agents that may be reactive to tin.
5. If sterilizing agent containing chlorine is used, the tinned surface must be thoroughly rinsed. Chlorine is corrosive to tin.
6. Dry thoroughly after rinsing and store in a dry environment.
7. If water is exceptionally hard, drying will be necessary to prevent spotting.

## MAINTENANCE



### ROTATING GRINDING WORM TO AVOID SERIOUS PERSONAL INJURY

**ALWAYS** Turn Off, Unplug From Power Source and Perform Lockout/Tagout Procedure to This Machine **BEFORE** Servicing.

**NEVER** Touch This Machine Without Training and Authorization By Your Supervisor.

**NEVER** Place Hands Into Machine Input or Output Openings.

**NEVER** Bypass, Alter, or Modify This Equipment in Any Way From Its Original Condition.

**PROMPTLY REPLACE** Any Worn or Illegible Labels.

**USE ONLY GENUINE BIRO** Parts and accessories Properly Installed.

#### A. GRINDING BOWL INSTALLATION

1. Mount the grinding bowl on the two threaded studs on the front of the machine. Tighten in position with provided nuts.
2. Place the grinding worm in the grinding bowl and fully seat rear drive tang into worm drive shaft.
3. Install knife, breaker plate and end retaining ring.



#### ONLY HAND TIGHTEN RETAINING RING

4. When the bowl assembly is mounted and tight, there should be approximately  $\frac{1}{8}$ " gap between the back inside wall of the bowl and the back of the worm (SEE FIGURE 1). The bowl ring wrench which is provided with each grinder is used only for **REMOVAL** of the end retaining ring for cleaning purposes or for changing knife and breaker plate.
5. To check wear: With bowl assembly removed, place a straight edge across outside flange of aluminum bearing housing. The end of the worm drive shaft should just contact the straight edge, i.e. flange face and worm drive shaft end should be in the same plane (SEE FIGURE 2).

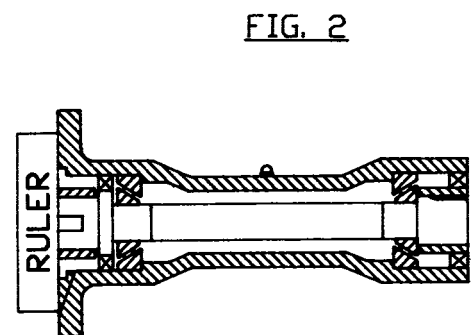
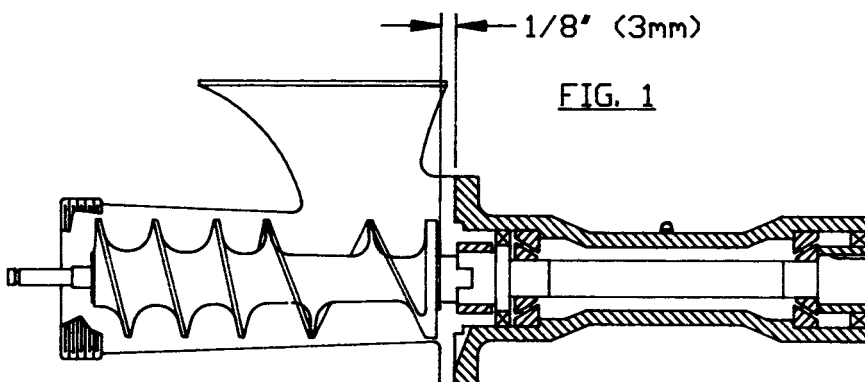

## **B. BEARING HOUSING LUBRICATION**

1. Unplug grinder from power source and perform lockout/tagout procedures.
2. Remove bolted on tray.
3. Check and relubricate with good grade of lithium bearing grease semi-annually.
4. Reinstall tray and bolt on tightly.

## **C. ROLLER CHAIN AND DRIVE SPROCKET LUBRICATION**

Chains should be protected against dirt and moisture. Chain life will vary appreciably depending upon its lubrication. The better the lubrication, the longer the chain life.

Lubrication effectiveness will vary with the amount of lubrication and frequency of application. Ideally, a lubricant film should always be present between the working parts. Manually lubricate the chain after the 1st six weeks then every 6 months thereafter.

Lubricating just the outside of the chain does little good. Apply lubrication on the inside of the chain span so that it will work through the moving parts and joints by centrifugal force as the chain rotates and reach the area where one surface "scrubs" another.

Recommended types of chain lubricant are those with Molybdenum Disulphide or Graphite added. Also bonded lubricants such as Dow Corning's Molykote 321R or equivalent are excellent for open chains. The lubricant should be of a viscosity whereby it will "flow" somewhat and penetrate the internal working surfaces. Thick stiff greases are of little value because they cannot work into moving parts of the chain.

Symptoms of Inadequate Lubrication:

1. Excessive noise
2. Chain becomes stiff
3. Chain runs hot
4. Broken pins, bushings or rollers
5. Excessive chain elongation — caused by wear on the pin outside diameter and pushing inside diameter  
Once a chain is elongated or worn past acceptable limits, jumping of sprocket teeth and/or improper chain/sprocket mesh will occur.

## **LUBRICATING CHAIN AND SPROCKETS**

1. Unplug grinder from power source and perform lockout/tagout procedures.
2. Remove bolted on tray.
3. Spray or brush lubricant on inside of chain, slowly and carefully turning large sprocket by hand.
4. Reinstall tray and bolt on tightly.

## **D. MAIN DRIVE CHAIN TENSION LUBRICATING CHAIN AND SPROCKETS**

1. Unplug grinder from power source and perform lockout/tagout procedure.
2. Remove feed tray.
3. Loosen motor mounting bolts.
4. Remove shims from under the motor. Important to remove same shims from back of motor as from the front for proper sprocket alignment.
5. Total chain flex should be  $\frac{1}{8}$ " to  $\frac{3}{8}$ " for proper chain tension. Do not over tension as this can cause excessive wear or premature failure of motor bearings and journal box bearings.
6. Retighten all motor mounting bolts.
7. Reinstall feed tray.

**IMPORTANT: Must have Model and Serial Number when ordering Parts**

# MAIN BODY AND DRIVE SYSTEM FOR 3, 5 AND 7½ HORSEPOWER GRINDERS

Applicable on Choppers Starting with Serial No. 2250

Part No.	Description
H301	Bearing box, aluminum
H301A	Bearing box assembly
H302	Main drive shaft, 2⅝ × 15¼ long
H303	Shaft collar, 2⅝ × 1¼ long
H304	Shaft nut, 2⅝ × 1¼ long
H305	Shaft spacer, 2⅝ × 1½
H306	Grease brg. box
H307	Bearing box grease fitting, ⅜
H308	Main shaft key, ⅝ × 3⅞ long
H309	Seal
H310A	Front bearing cup and cone assembly
H311A	Rear bearing cup and cone assembly
H313	Bowl studs, ½ × 3¼
H317	Switch rod, 20¾L
H317-1	Switch rod 20¾L after s/n 27182
H318	Aluminum switch cam (Ser. 9039 to 11260)
H318-1	Switch cam, nylon (before 9039 & after 11260)
H319	Switch handle
H322	Connection box cover
H324	Base fee, 1½", black pipe coupling
H325A	Base plate assembly
H327-11	Aluminum legs, 1½ × 11

H328	Switch lock collar
H331	Roll pin, ⅛ × 5⅝
H333	Model & serial number plate
H335A	Bevel collar trim 8" w/fastener
H346	Connection box
H366	½-13 hex nut, bowl & bowl stud locknut
H382	Motor pinion - 19 tooth - 60 Hz
H382-1	Motor pinion - 22 tooth for 50Hz
H383	Sprocket - 141 tooth
H384-CL	35-4 roller chain w/connecting link
H384-1	} SEE INSERT "A" "A" AT RIGHT
H384-2	
H384-3	
H386A	SS case assembly
H389-1	Carriage bolt, ⅝-18 × 4
H390	Hex nut, ½-13 motor attachment
H406	Grease for chain
H425	Motor shim 2" × 11"
H432	Box end bowl wrench ⅝
H462	Guard for switch toggle
H462-1	Guard ferrule
H476	Hex nut SS ⅝-18
H591	Bushing, switch rod
H591-1	Bushing lock nut
H592	Star washer, switch rod bushing
H653-E	Warning label, English
H653-SP	Warning label, Spanish

Part No.	Description
H379	3 hp, 220/440-50/60-3
H380-U	5 hp, 220/440-50/60-3
H380-5B	5 hp, 230-50/60-1
H381-U	7½ hp, 220/440-50/60-3

## NOT SHOWN

14572 ..... Ring wrench hanger

## INSERT A

To convert machines S/N2250 to 3173 equipped with 2" Silent Chain, 2½" Silent Chain, or 35-3 Roller Chain will require:

- 1 Ea. H382 Motor Sprocket
- 1 Ea. H383 Main Sprocket
- 1 Ea. H384-CL 35-4 Roller Chain w/Connecting Link

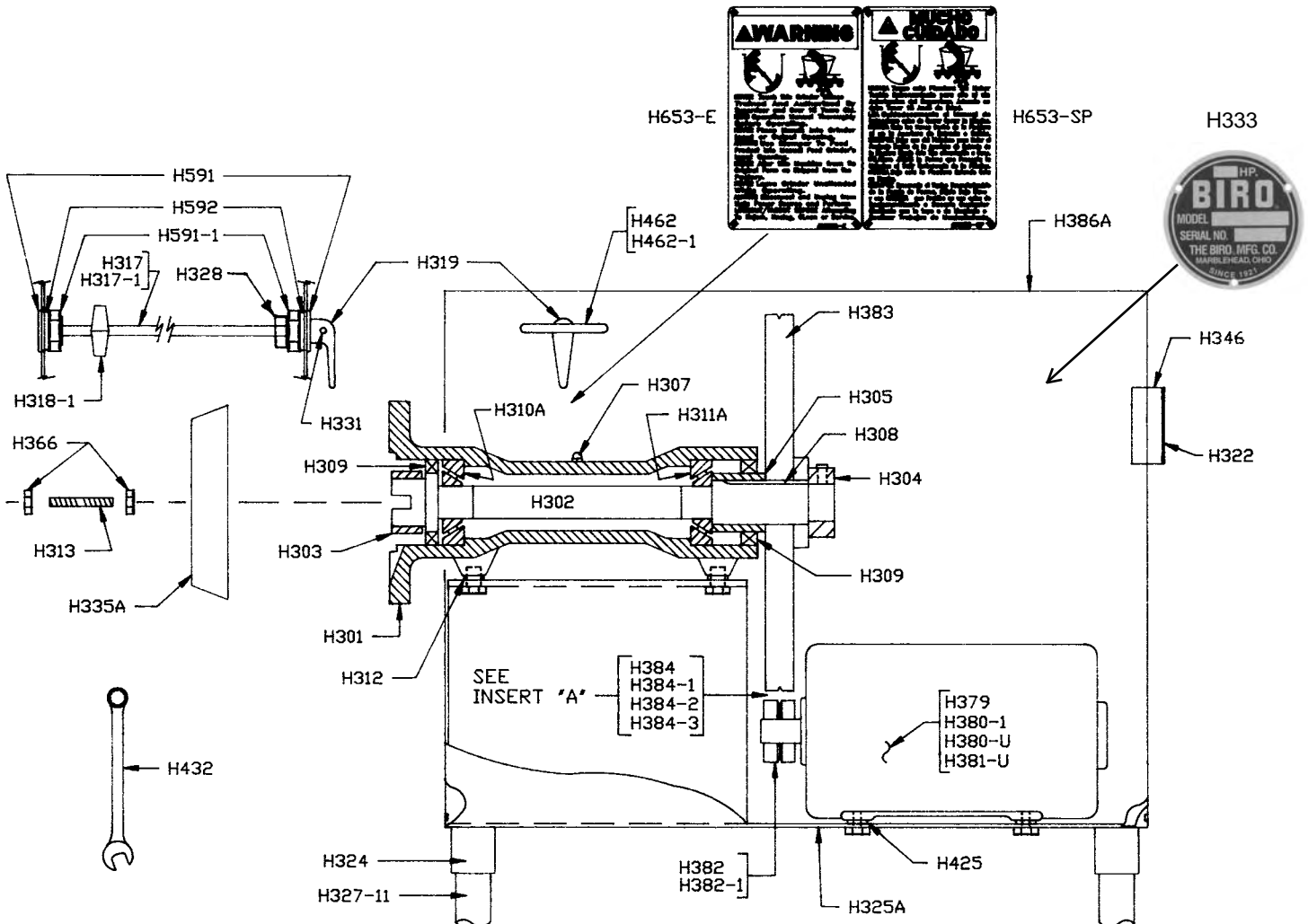

**IMPORTANT: Must have Model and Serial Number when ordering Parts**

# MAIN BODY AND DRIVE SYSTEM FOR 3, 5 AND 7½ HORSEPOWER GRINDERS

Applicable on Choppers Starting with Serial No. 2250

## GRINDER HORSEPOWER AND BOWL SIZE AVAILABLE

Model 342 — 3 HP — #42 size bowl — tinned  
 Model 548 — 5 HP — #48 size bowl — tinned  
 Model 552 — 5 HP — #52 size bowl — tinned  
 Model 7548 — 7.5 HP — #48 size bowl — tinned  
 Model 7552 — 7.5 HP — #52 size bowl — tinned

42 Bowl Section	
Part Number	Description
HC42A	Bowl Assembly
HC42	Bowl
HS42A	Worm assembly
HR42/48	Ring
HK48	Knife drive pin
HP48	Bowl Pin
H340	Aluminum ring wrench

48 Bowl Section	
Part Number	Description
HC48A	Bowl assembly
HC48	Bowl
HS48A	Worm assembly
HR42/48	Ring
HK48	Knife drive pin
HP48	Bowl pin
H340	Aluminum ring wrench

52 Bowl Section	
Part Number	Description
HC52A	Bowl assembly
HC52	Bowl
HS52A	Worm assembly
HR52	Ring
HK52	Knife drive pin, fine thread, to #26795
HK52/56	Knife drive pin, coarse thread, #26796 on
HP52	Bowl pin
H340	Aluminum ring wrench

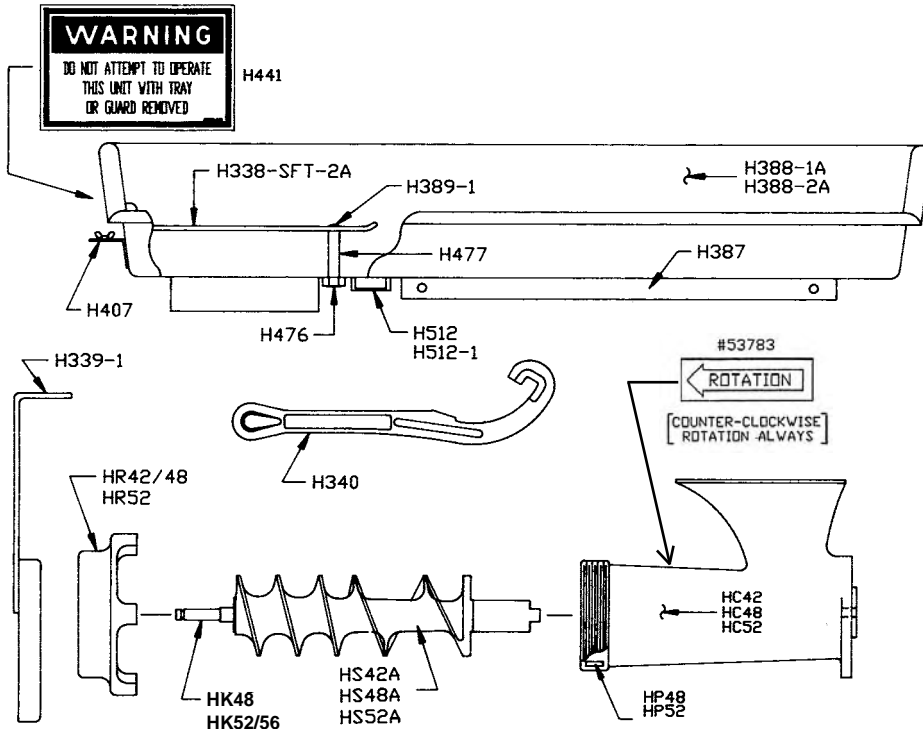

Tray Section For 3, 5, 7 Horsepower	
Part Number	Description
H339-1	Spurt guard for SS tray
H388-1A	Left hand tray assembly, SS
H388-2A	Right hand tray assembly, SS
H338-SFT-2A	Tray guard assem. for SS tray
H387	Tray angles, .0625 × 1¼ × 29
H389-1	Carriage bolt, ⅝-18 × 4
H404SFT	Stomper, 12½" long
H404SFT-SLD	Solid stomper, 12½"
H407	Wing nut, ⅝ SS tray only
H441	Warning decal
H476	Hex nut SS ⅝-18
H477	SS stand off for tray guard
H512	Magnet housing
H512-1	Magnet ser. no. 26628 on

## BOWL, RING, & WORM IDENTIFICATION ALL DIMENSIONS IN INCHES

MODEL	42	48	52
ITEM NO.	HC42	HC48	HC52
A	5.00	5.00	6-1/2
B	10-9/32	13-27/32	13-7/32

ITEM NO.	HR42/48	HR52
E	7-13/16	9.00
F	MAJOR DIA.	5.00
	MINOR DIA.	4.81
G	3-9/16	4-21/32

MODEL	42	48	52
ITEM NO.	HS42A	HS48A	HS52A
C	10-5/16	13-7/8	12-13/16
D	11-13/16	15-3/8	15-1/16

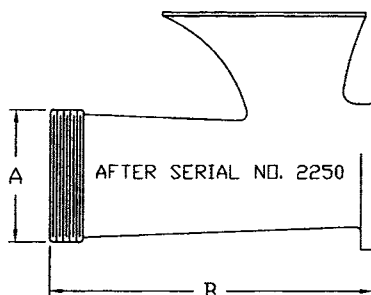

AFTER SERIAL NO. 2250

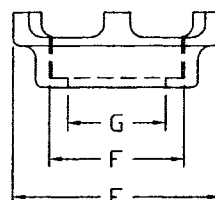

AFTER SERIAL NO. 2250

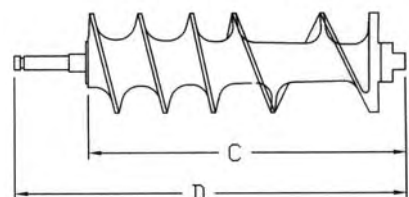

IMPORTANT: Must have Model and Serial Number when ordering Parts

## ELECTRICAL CONTROLS 3, 5 AND 7½ HORSEPOWER GRINDERS

FROM SERIAL NO. 2250 TO  
SERIAL NO. 5239

ORIGINALLY EQUIPPED WITH ALLEN BRADLEY 609-BAA MANUAL STARTER WITHOUT MAGNETIC SAFETY SWITCH. THESE SWITCHES ARE OBSOLETE AND MUST BE UPDATED TO THE APPROPRIATE AEG EQUIVALENT. ORDER H478AE (SPECIFY HP AND VOLTS TO COMPLETE NUMBER). AEG SWITCH ASSEMBLY MUST BE INSTALLED BY A QUALIFIED BIRO SERVICE AGENCY.

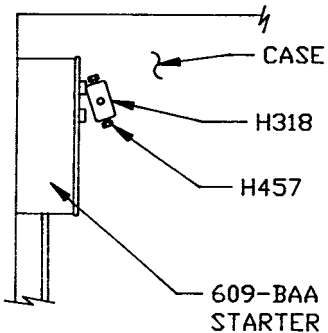
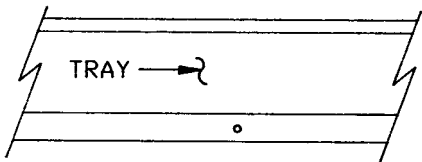

FROM SERIAL NO. 9039 TO  
SERIAL NO. 11260

ORIGINALLY EQUIPPED WITH ALLEN BRADLEY 609U-BAA MANUAL STARTER WITH MAGNETIC SAFETY SWITCH. THESE SWITCHES ARE OBSOLETE AND MUST BE UPDATED TO THE APPROPRIATE AEG EQUIVALENT. ORDER H478AE (SPECIFY HP AND VOLTS TO COMPLETE NUMBER). AEG SWITCH ASSEMBLY MUST BE INSTALLED BY A QUALIFIED BIRO SERVICE AGENCY.

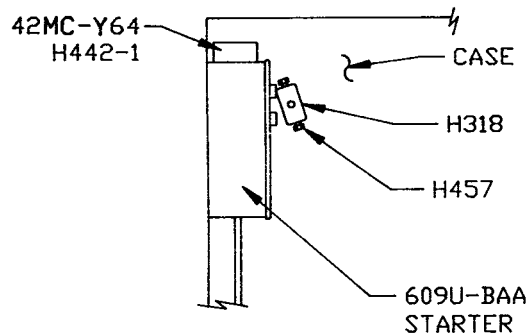
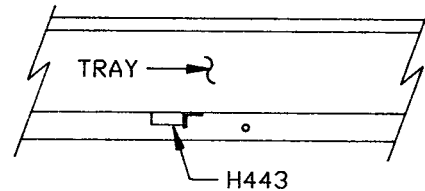

### CONVERSION TO AEG STARTER

FROM SERIAL NO. 2250 TO SERIAL NO. 11260 WHEN REPLACING AN ALLEN BRADLEY SERIES 609 STARTER WITH AN AEG STARTER. NEW HOLE LOCATIONS MUST BE DRILLED IN THE MACHINE CASE FOR MOUNTING THE STARTER AND RELOCATING THE SWITCH ROD AS SHOWN IN THE DIAGRAM.

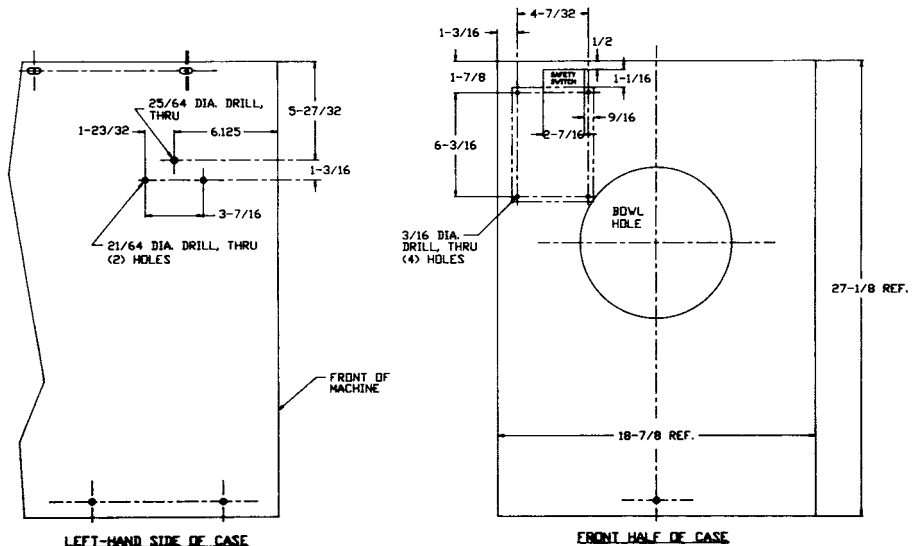

**FROM SERIAL NO. 5240 TO  
SERIAL NO. 9038 AND SERIAL NO.  
11281 TO SERIAL NO. 24807**

ORIGINALLY EQUIPPED WITH ALLEN BRADLEY 709-BAA MAGNETIC STARTER WITH MAGNETIC SAFETY SWITCH AND AN ALLEN BRADLEY 800S-2SA START-STOP STATION. THE START-STOP STATION IS STILL AVAILABLE, BUT THE 709-BAA IS OBSOLETE AND NOT AVAILABLE. UNITS REQUIRING REPLACEMENT OR REPAIR MUST BE UPDATED WITH THE APPROPRIATE AEG STARTER. ORDER H478AE (SPECIFY HP & VOLTS TO COMPLETE NO.)-LB. AEG SWITCH ASSEMBLY LESS BUTTONS. THIS SWITCH ASSEMBLY MUST BE INSTALLED BY A QUALIFIED BIRO SERVICE AGENCY.

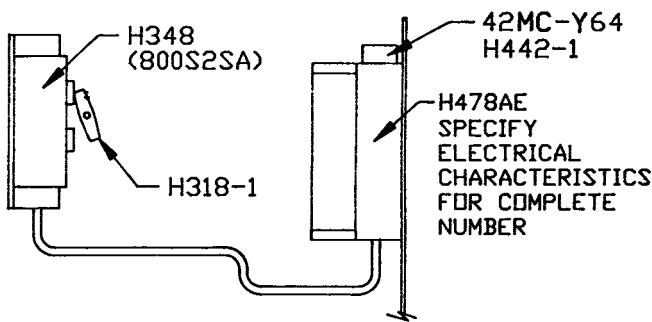

USING 10 & 15 HP WIRING  
DIAGRAM ON PAGE 10

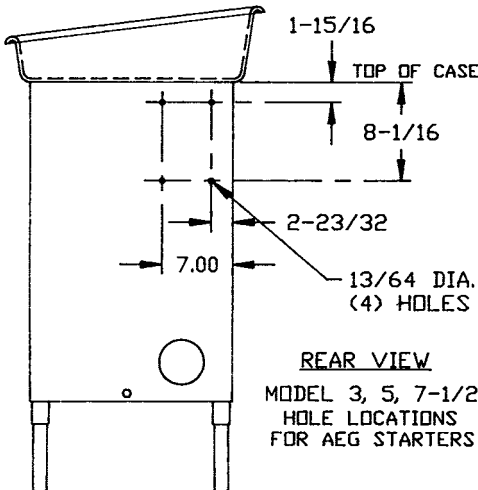

**AEG Switch Section**

Part Number	Description
H318-1	Switch cam, nylon #5240-9038 & #11281 to present
42MC-Y64	Magnetic safety switch, low voltage
H442-1	Magnetic safety switch, high voltage
H478AE-21A-LB	Switch assembly less buttons BAEG/3-C12 (3HP-208/220/230V)
H478AE-23A-LB	Switch assembly less buttons BAEG/3-E6 (3HP-440V)
H478AE-25A-LB	Switch assembly less buttons BAEG/5-C17 (5HP-208/220/230V)
H478AE-27A-LB	Switch assembly less buttons BAEG/5-E12 (5HP-440V)
H478AE-30A-LB	Switch assembly less buttons BAEG/7.5-C23 (7.5HP-208/220/230V)
H478AE-32A-LB	Switch assembly less buttons BAEG/7.5-E17 (7.5HP-440V)

**SERIAL NO. 24808 TO 26493**

ORIGINALLY EQUIPPED WITH STROMBERG STARTER WITH PUSH BUTTONS AND MAGNETIC SAFETY SWITCH AS ONE UNIT. THE STROMBERG STARTER AND INTERNAL COMPONENTS ARE NO LONGER AVAILABLE. REPLACEMENT REQUIRES UPDATE TO APPROPRIATE AEG EQUIVALENT.

**SERIAL NO. 24808 TO PRESENT**

EQUIPPED WITH AEG STARTER WITH PUSH BUTTONS AND MAGNETIC SAFETY SWITCH AS ONE UNIT.

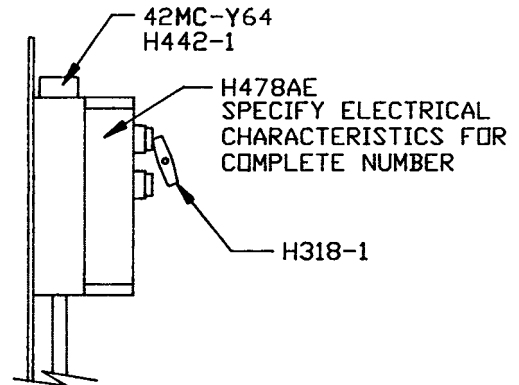

USED ON ALL 3, 5, 7-1/2 HP  
GRINDER SWITCH SYSTEMS

**AEG Switch Section**

Part Number	Description
H318-1	Switch cam, aluminum (#2250-5239 & #9039-11280)
H42MC-Y64	Magnetic safety switch, low voltage
H442-1	Magnetic safety switch, high voltage
H457	Square head screw
H478AE-21A	Switch assembly BAEG/3-C12 (208/220V)
H478AE-22A	Switch assembly BAEG/3-D6 (380/415V)
H478AE-23A	Switch assembly BAEG/3-E6 (440V)
H478AE-24A	Switch assembly BAEG/3-F6 (550V)
H478AE-25A	Switch assembly BAEG/5-C17 (208/220V)
H478AE-26A	Switch assembly BAEG/5-D12 (380/415V)
H478AE-27A	Switch assembly BAEG/5-E12 (440V)
H478AE-28A	Switch assembly BAEG/5-F8 (550V)
H478AE-29A	Switch assembly BAEG/5S-C32 (230V-1PH)
H478AE-30A	Switch assembly BAEG/7.5 C23 (208/220V)
H478AE-31A	Switch assembly BAEG/7.5-D17 (380/415V)
H478AE-32A	Switch assembly BAEG/7.5-E17 (440V)
H478AE-33A	Switch assembly BAEG/7.5-F12 (550V)
H479AE-220	Contactor SP27.10-C0 (208/220/230V)
H479AE-380	Contactor SP27.10-D0 (380/415V)
H479AE-440	Contactor SP27.10-E0 (440V)
H479AE-550	Contactor SP27.10-F0 (550V)
H481AE-51	Overload B27S-K (3HP-380/440/550V)
H481AE-52	Overload B27S-L (5HP-550V)
H481AE-53	Overload B27S-M (3HP-220V; 5HP-380/415/440V) (7.5HP-550V)
H281AE-31	Overload B27S-N (5HP-220V; 7.5HP-380/415/440V) (10HP-380/415/440/550V)
H281AE-32	Overload B27S-O (7.5HP-220V) (15HP-380/415/440/550V)
H281AE-33	Overload B27S-P (5HP-230V-1PH; 10HP-220V)
H478AE-ENCL-PB	WT enclosure w/button holes (3/5/7.5HP)
H482-1	Green Push Button (3.5, 7/2HP)
H482-2	Red Push Button (3.5, 7/2HP)

**IMPORTANT: Must have Model and Serial Number when ordering Parts**

# MAIN BODY AND DRIVE SYSTEM FOR 10 AND 15 HORSEPOWER GRINDERS

Applicable on Choppers Starting with Serial No. 2250

Part No.	Description
H101	Bearing box
H101A	Bearing box assembly
H102	Main drive shaft, 3/4 rd x 15 1/2
H103	Shaft collar, 3/4 x 1
H104	Shaft nut 3/4 x 1 1/4
H105	Shaft spacer 3/4 x 1 1/4
H109	Seal
H110A	Front bearing cup & cone assembly
H111A	Rear bearing cup & cone assembly
H113	Bowl stud 3/4-10 x 4
H117	Switch rod, 24 1/4 L
H117-1	Switch rod 23 3/8 L after s/n 27192
H125A	Base plate assembly
H127S-6	Steel legs, 1 1/2 x 6
H135A	Bevel collar trim — 10 w/fastener
H182	Motor pinion — 17 tooth — 60 Hz
H182-1	Motor pinion — 21 tooth — 50Hz
H183	128 tooth sprocket
H184	3" silent chain
H184-1	Master link 1/2 pitch 3"
H186A	Case assembly, stainless
H222	Hex nut for bowl stud, 3/4

H224	Motor shim, 1 x 2 CF, 11" long, 10, 15 HP
H225	Motor Shim, 1/8 x 2 x 11 (use H425)
H232	Box end wrench, 1"
H306	Grease, brg. box
H307	Bearing box grease fitting,
H308	Main shaft key, 3 long
H318-1	Switch cam, nylon
H319	Switch handle
H322	Connection box cover
H324	Base feet, 1 1/2", black pipe coupling
H328	Switch rod collar
H331	Roll pin, 1/8 x 5/8
H333	Model & serial number plate
H346	Connection box
H389-1	Carriage bolt, 5/16-18 x 4
H390	Hex nut, 1/2-13 motor attachment
H406	Grease for chain
H462	Guard for switch toggle
H462-1	Guard ferrule
H476	Hex nut SS 5/16-18
H591	Bushing, switch rod
H591-1	Bushing lock nut
H592	Star washer, switch rod bushing
H653-E	Warning label, English
H653-SP	Warning label, Spanish

Part No.	Description
H179-U	10 hp, 220/440-50/60-3
H180-B	15 hp, 220/440-50/60-3

Part No.	Description
14572	Ring wrench hanger

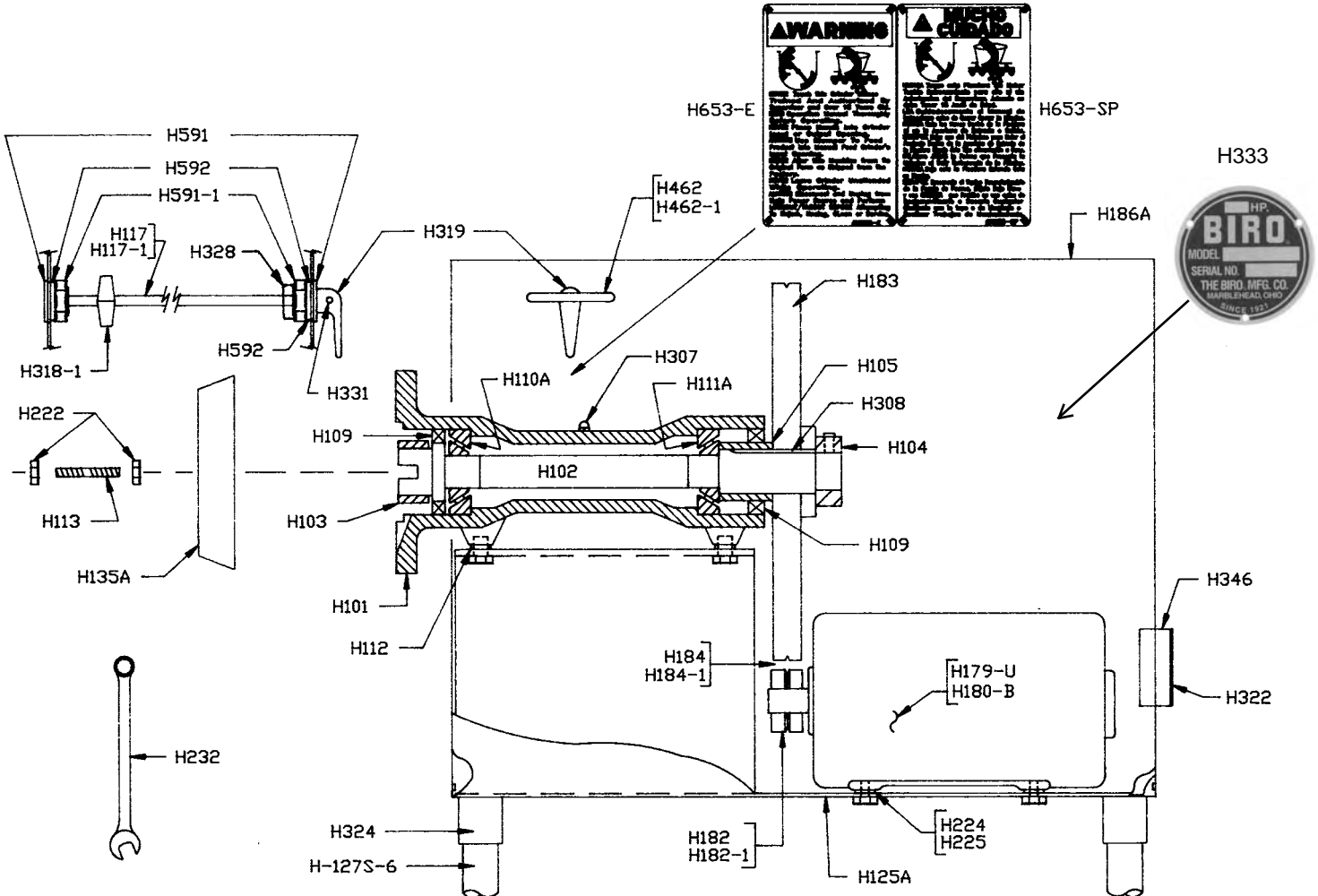



**IMPORTANT: Must have Model and Serial Number when ordering Parts**

# MAIN BODY AND DRIVE SYSTEM FOR 10 AND 15 HORSEPOWER GRINDERS

Applicable on Choppers Starting with Serial No. 2250

## GRINDER HORSEPOWER AND BOWL SIZE AVAILABLE

Model 1056 — 10 HP — #56 size bowl — tinned  
Model 1556 — 15 HP — #56 size bowl — tinned

56 Bowl Section	
Part Number	Description
HC56A	Bowl assembly
HC56	Bowl
HS56A	Worm assembly
HR56	Ring
HP56	Bowl pin
HK52/56	Knife drive pin
H235	Bowl spurt guard stud
H340	Aluminum ring wrench

Tray Section 10 and 15 Horsepower	
Part Number	Description
H139	Spurt Guard
H188A	Left hand tray assembly, SS
H188-2A	Right hand tray assembly, SS
H187	SS tray angle
H338-SFT-2A	Tray guard assem. for SS tray
H389-1	Carriage bolt, $\frac{5}{16}$ -18 x 4
H404SFT	Stomper, 12 $\frac{1}{2}$ " long
H404SFT-SLD	Solid stomper, 12 $\frac{1}{2}$ "
H407	Wing nut, SS tray only
H441	Warning decal
H476	Hex nut SS $\frac{5}{16}$ -18
H477	SS stand off for tray guard
H512	Magnet housing
H512-1	Magnet S/N 26628 on

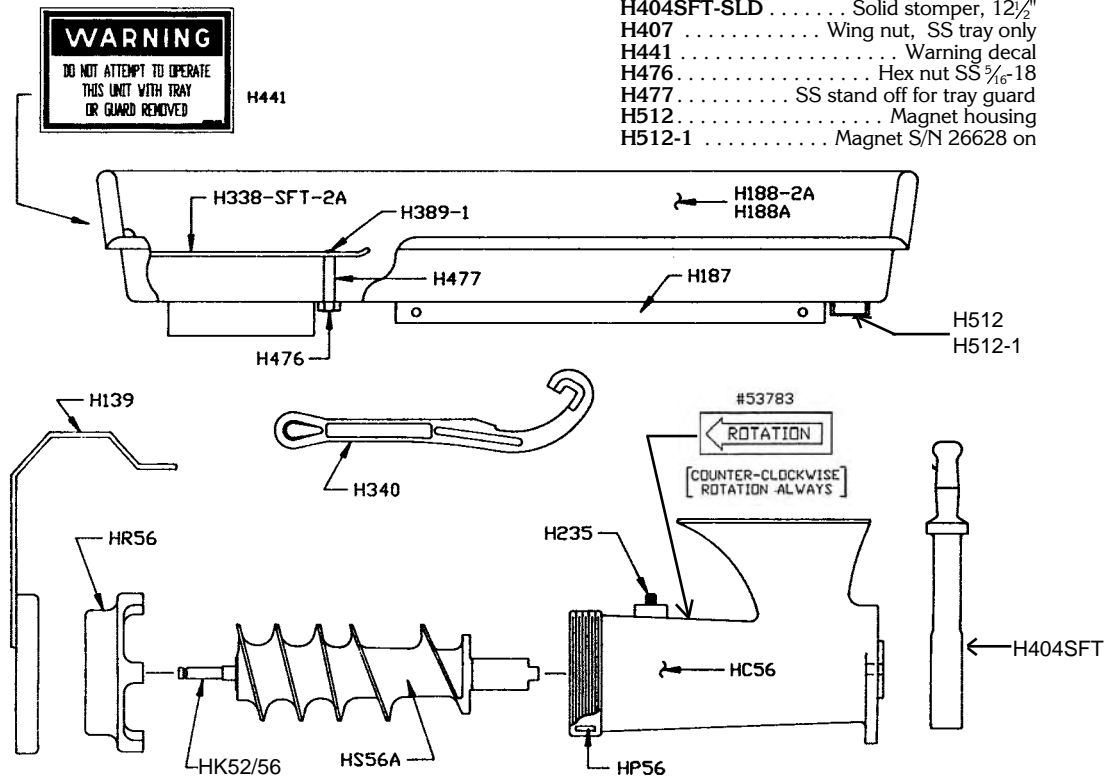

## BOWL, RING, & WORM IDENTIFICATION ALL DIMENSIONS IN INCHES

ITEM NO.	HC56
A	6-7/8
B	16-25/32

ITEM NO.	HR56
E	9-5/16
F	MAJOR DIA. 6-7/8
F	MINOR DIA. 6.68
G	5-3/8

ITEM NO.	HS56A
C	16-7/16
D	18-11/16

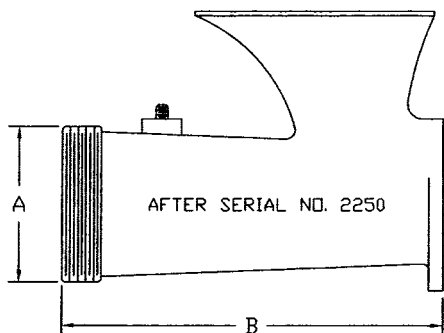

AFTER SERIAL NO. 2250

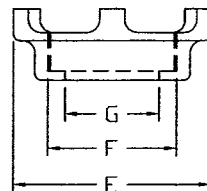

AFTER SERIAL NO. 2250

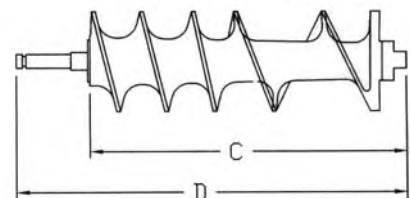

**IMPORTANT: Must have Model and Serial Number when ordering Parts**

## ELECTRICAL CONTROLS 10 AND 15 HORSEPOWER GRINDERS

**FROM SERIAL NO. 2250  
TO SERIAL NO. 24729**

ORIGINALLY EQUIPPED WITH ALLEN BRADLEY 709-BAA MAGNETIC STARTER WITH MAGNETIC SAFETY SWITCH AND AN ALLEN BRADLEY 800S-2SA START-STOP STATION. THE START-STOP STATION IS STILL AVAILABLE, BUT THE 709-BAA IS OBSOLETE AND NOT AVAILABLE. UNITS REQUIRING REPLACEMENT OR REPAIR MUST BE UPDATED WITH THE APPROPRIATE AEG STARTER. ORDER H278AE (SPECIFY HP & VOLTS TO COMPLETE NO.) AEG SWITCH ASSEMBLY. THIS SWITCH ASSEMBLY MUST BE INSTALLED BY A QUALIFIED BIRO SERVICE AGENCY.

**FROM SERIAL NO. 24780  
TO SERIAL NO. 26586**

ORIGINALLY EQUIPPED WITH STROMBERG STARTER WITH MAGNETIC SAFETY SWITCH AND AN ALLEN BRADLEY 800S-2SA START-STOP STATION. THE START-STOP STATION IS STILL AVAILABLE, BUT THE STROMBERG STARTER AND INTERNAL COMPONENTS ARE NO LONGER AVAILABLE. REPLACEMENT REQUIRES UPDATE TO APPROPRIATE AEG EQUIVALENT.

**FROM SERIAL NO. 24780  
TO PRESENT**

EQUIPPED WITH AEG MAGNETIC STARTER AND AN ALLEN BRADLEY 800S-2SA START-STOP STATION.

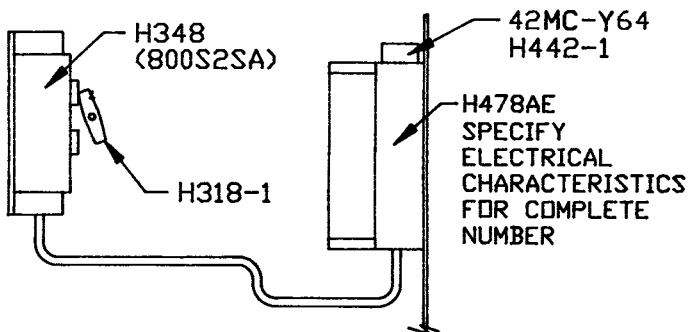

AEG Switch Section	
Part Number	Description
H277	SO Cord, 16/4 (10, 15HP push button to starter)
H278AE-11A	Switch Assembly, BAEG/10-C32 (220V)
H278AE-12A	Switch Assembly, BAEG/10-D17 (380/415V)
H278AE-13A	Switch Assembly, BAEG/10-E17 (440V)
H278AE-14A	Switch Assembly, BAEG/10-F17 (550V)
H278AE-15A	Switch Assembly, BAEG/15-C50 (220V)
H278AE-16A	Switch Assembly, BAEG/15-D23 (380/415V)
H278AE-17A	Switch Assembly, BAEG/15-E23 (440V)
H278AE-18A	Switch Assembly, BAEG/15-F23 (550V)
H279AE-220	Contactors SP37.10-C0 (208/220/230V)
H279AE-380	Contactors SP37.10-D0 (380/415V)
H279AE-440	Contactors SP37.10-E0 (440V)
H279AE-550	Contactors SP37.10-F0 (550V)
H281AE-31	Overload B27S-N (5HP-220V; 7.5HP-380/415/440V) (10HP-380/415/440/550V)
H281AE-32	Overload B27S-O (5HP-220V) (15HP-380/415/440/550V)
H281AE-33	Overload B27S-P (5HP-230V-1PH; 10HP-220V) (10HP-380/415/440/550V)
H281AE-34	Overload B77S-QN (15HP-220V)
H278AE-ENCL	WT enclosure less button holes (10/15HP)
H318-1	Switch cam, nylon (before 9039 & 11281 to present)
H348	Push button station 800S2SA
42MC-Y64	Magnetic safety switch, low voltage
H442-1	Magnetic safety switch, high voltage

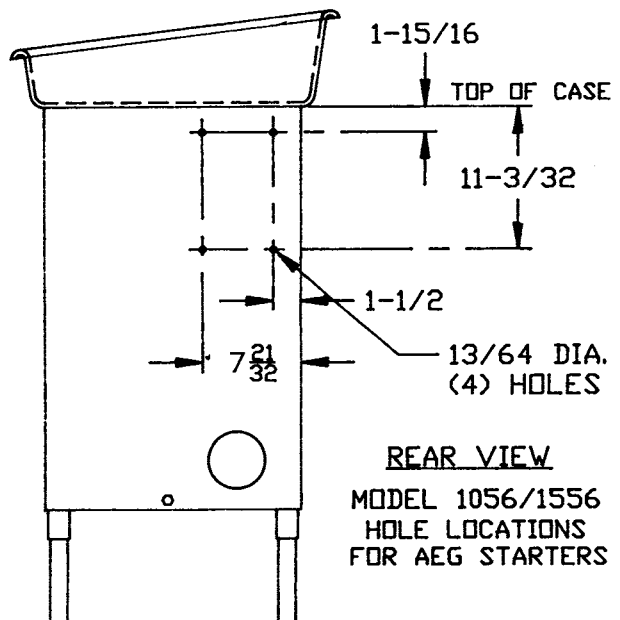



## LIMITED WARRANTY

**WARRANTY:** The BIRO Manufacturing Company warrants that the BIRO Heavy Horsepower Grinder will be free from defects in material and workmanship under normal use and with recommended service. BIRO will replace defective parts, which are covered by this limited warranty, provided that the defective parts are authorized for return, shipping charges prepaid, to a designated factory for inspection and/or testing.

**DURATION OF WARRANTY:** The warranty period for all parts covered by this limited warranty is one (1) year from date of Inspection/Demonstration advised on the returned Warranty Registration card, or eighteen (18) months from original factory ship date, whichever occurs first, except as noted below.

**PARTS NOT COVERED BY WARRANTY:** The following are **not** covered by this limited warranty: wearable parts in the grinding system such as bowl, ring, worm, drive shaft, and knife drive pin. This limited warranty does not apply to machines sold as used, rebuilt, modified, or altered from the original construction in which the machine was shipped from the factory. (WATER CONTAMINATED ELECTRICAL SYSTEMS ARE NOT COVERED UNDER THIS LIMITED WARRANTY.) BIRO is not responsible for electrical connection of equipment, adjustments to switch controls or any other electrical requirements, which must be performed only by a certified electrician. BIRO is not responsible for service charges or labor required to replace any part covered by this limited warranty or for any damages resulting from misuse, abuse, lack of proper or recommended service.

**EXCLUSION OF WARRANTIES AND LIMITATION OF REMEDIES:** BIRO gives no warranties other than those expressly stated in this limited warranty. THE IMPLIED WARRANTY OF MERCHANTABILITY, THE IMPLIED WARRANTY OF FITNESS FOR PROCESSING FOOD PRODUCTS, AND ALL OTHER IMPLIED WARRANTIES ARE SPECIFICALLY EXCLUDED. BIRO IS NOT LIABLE FOR CONSEQUENTIAL OR INCIDENTAL DAMAGES, EXPENSES, OR LOSSES. THE REMEDIES PROVIDED IN THIS BIRO LIMITED WARRANTY ARE PURCHASER'S SOLE AND EXCLUSIVE REMEDIES AGAINST BIRO.

**REGISTRATION CARDS:** You must sign, date and complete the warranty registration card supplied with each machine. The warranty card must be returned to The Biro Manufacturing Company for proper registration. If no warranty card is returned to BIRO, the warranty period will begin from the date the machine was originally shipped from the factory.

### HOW TO GET SERVICE:

1. Contact the agency from whom you purchased the machine; or
2. Consult the yellow pages of the phone directory for the nearest authorized dealer; or
3. Contact Biro Mfg. Company for the nearest authorized service entity (250 plus worldwide) in your area.

## THE BIRO MANUFACTURING COMPANY

1114 Main Street  
Marblehead, Ohio 43440-2099  
Ph. 419-798-4451  
Fax 419-798-9106  
E-mail: [Service@biro.saw.com](mailto:Service@biro.saw.com)  
Web: <http://www.birosaw.com>