



HEG / RRE / WEG Series Griddle



VULCAN
HEG24E
HEG36E
HEG48E
HEG60E
HEG72E
RRE24E
RRE36E
RRE48E

WOLF
WEG24E
WEG36E
WEG48E
WEG60E
WEG72E

This Manual is prepared for the use of trained Vulcan Service Technicians and should not be used by those not properly qualified.

This manual is not intended to be all encompassing. If you have not attended a Vulcan Service School for this product, you should read, in its entirety, the repair procedure you wish to perform to determine if you have the necessary tools, instruments and skills required to perform the procedure. Procedures for which you do not have the necessary tools, instruments and skills should be performed by a trained Vulcan Service Technician.

The reproduction, transfer, sale or other use of this Manual, without the express written consent of Vulcan, is prohibited.

This manual has been provided to you by ITW Food Equipment Group LLC ("ITW FEG") without charge and remains the property of ITW FEG, and by accepting this manual you agree that you will return it to ITW FEG promptly upon its request for such return at any time in the future.

For additional information on Vulcan-Hart Company or to locate an authorized parts and service provider in your area, visit our website at www.vulcanequipment.com

TABLE OF CONTENTS

GENERAL	3
INTRODUCTION	3
MODELS COVERED	3
INSTALLATION	3
CLEANING PROCEDURES	3
TOOLS AND TEST EQUIPMENT	3
LUBRICATION	3
OPERATING CONTROLS	3
THERMOSTAT	3
INDICATOR LIGHT	3
REMOVAL AND REPLACEMENT OF PARTS	4
GRIDDLE SERVICE POSITION	4
HEATING ELEMENT REPLACEMENT	4
THERMOSTAT REPLACEMENT	6
SERVICE PROCEDURES AND ADJUSTMENTS	8
THERMOSTAT CALIBRATION PROCEDURES	8
TESTING VOLTAGE TO HEATER(S)	9
ELECTRICAL OPERATION	10
PROCEDURE OF OPERATION	10
24" WIRING DIAGRAM	11
24" SCHEMATIC	12
1 & 3 PHASE	12
2 PHASE, 3 WIRE	12
36" WIRING DIAGRAM	14
36" SCHEMATIC	14
1 & 3 PHASE	14
2 PHASE, 3 WIRE	15
48" WIRING DIAGRAM	17
48" SCHEMATIC	17
1 & 3 PHASE	17
3 PHASE, 4 WIRE	18
60" WIRING DIAGRAM	19
60" SCHEMATIC	20
1 & 3 PHASE	20
2 PHASE, 3 WIRE	21
72" WIRING DIAGRAM	22
72" SCHEMATIC	23
1 & 3 PHASE	23
2 PHASE, 3 WIRE	24
TROUBLESHOOTING	26
TROUBLESHOOTING	26

GENERAL

INTRODUCTION

This manual is applicable to the models and ML numbers on the cover page. Procedures apply to all models unless specified otherwise.

MODELS COVERED

Vulcan Brand		
Models	Length	Depth
HEG24E	24"	24"
HEG36E	36"	24"
HEG48E	48"	24"
HEG60E	60"	24"
HEG72E	72"	24"

Vulcan Brand		
Models	Length	Depth
RRE24E	24"	24"
RRE36E	36"	24"
RRE48E	48"	24"

Wolf Brand		
Models	Length	Depth
WEG24E	24"	24"
WEG36E	36"	24"
WEG48E	48"	24"
WEG60E	60"	24"
WEG72E	72"	24"

INSTALLATION

Generally, all installation are made by the dealer or others contracted by the dealer or owner. Detailed installation instructions are included in the "Installation and Owners Manual" for the appropriate model.

CLEANING PROCEDURES

Detailed cleaning procedures are included in the "Installation and Owners Manual" for the appropriate model.

TOOLS AND TEST EQUIPMENT

Tools Required

- Standard set of hand tools.
- VOM with AC current tester.

NOTE: VOM sensitive of at least 20,000 ohms/volt can be used.

Special

- Thermocouple type, griddle or surface mount, temperature tester.
- 2 each, 8 inch long 4 x 4 wooden blocks.

LUBRICATION

1. Anti seeping coumpound
2. Penetrating oil
3. Finger Nail Polish

OPERATING CONTROLS

Thermostat

With the dial set to the desired setting, the temperature of the griddle section is maintained. When the operator turns the thermostat dial to OFF, electrical power is removed from the heating unit. Each thermostat controls a 12 inch wide section of the griddle surface.

Indicator Light

A red light will energize automatically for each section of the griddle when the thermostat is set, and will de-energize when the section has reached the thermostat setting. The light will energize and de-energize during the cooking operation to show that current temperature is being maintained.

REMOVAL AND REPLACEMENT OF PARTS

GRIDDLE SERVICE POSITION



WARNING Disconnect the electrical power to the machine and follow lockout / tagout procedures.

WARNING Griddle plate might be hot.

Griddle Service Position

1. Remove thermostat knobs.
2. Remove front trim panel screws and remove front trim panel.

NOTICE Do not damage indicator lights when removing front trim panel.

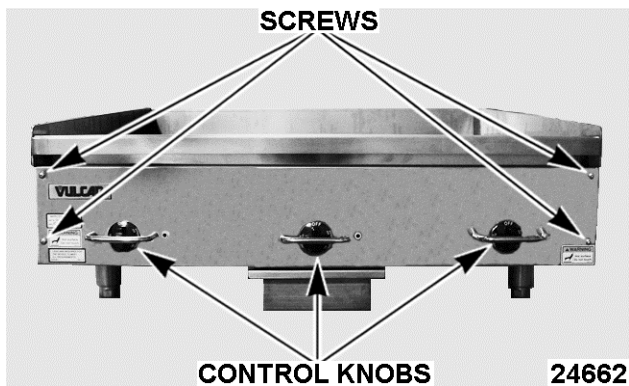

Fig. 1

3. Remove griddle plate assembly mounting bolts, left and right side.

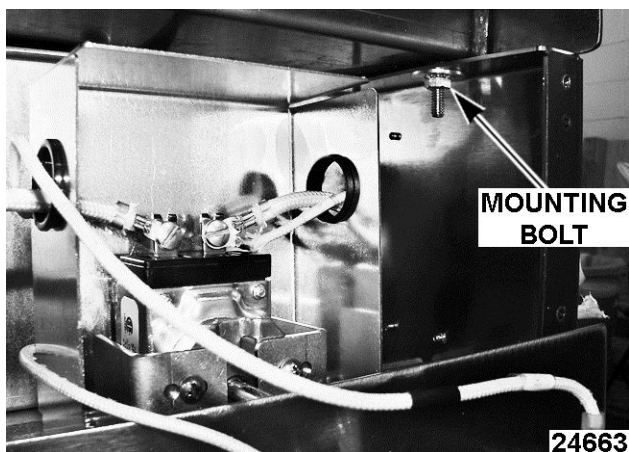

Fig. 2

WARNING Lift griddle plate straight up to prevent the griddle plate from sliding to the left or right.

4. Lift griddle plate up, to add two 4 x 4 blocks between the griddle plate and left and right sides of unit, approximately 6 to 7 inches.

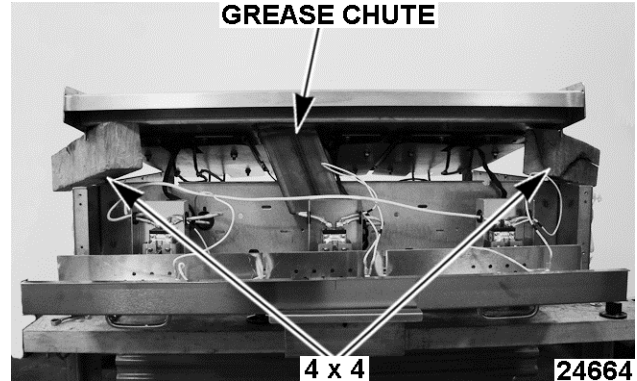

Fig. 3

NOTICE Verify Grease Chute does not raise past the heater element panel. This helps prevent the top from sliding to the rear.

WARNING Use 4 x 4, or greater, blocks to support griddle top. Do **NOT** use 2 x 4 blocks as they can tip over and lower griddle plate.

HEATING ELEMENT REPLACEMENT



WARNING Disconnect the electrical power to the machine and follow lockout / tagout procedures.

WARNING Griddle plate might be hot.

Heating Element Removal

1. Place griddle plate into GRIDDLE SERVICE POSITION.
2. Remove front heater element jumper wire connection.

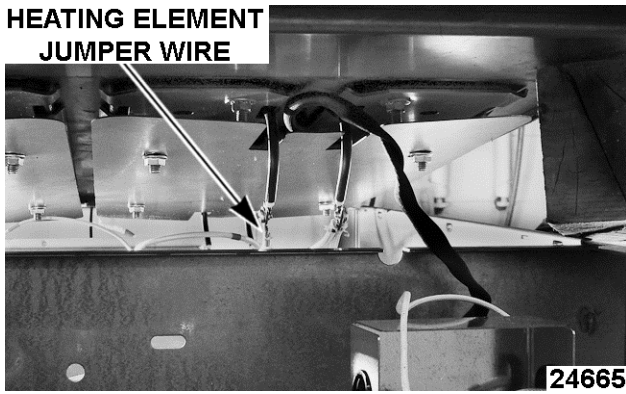

Fig. 4

NOTICE When removing heater element jumper wire screw, support heater element.

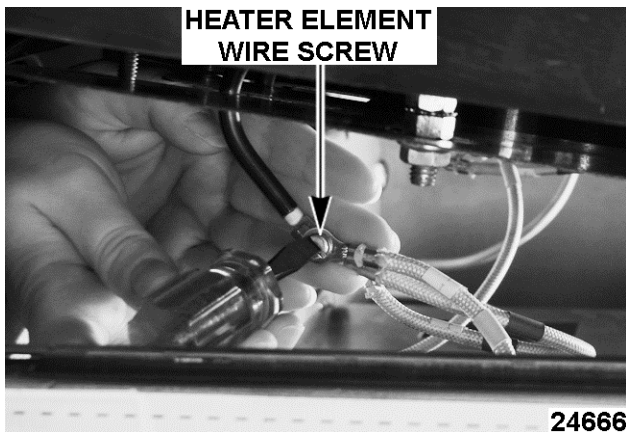

Fig. 5

3. Remove element baffle shield.

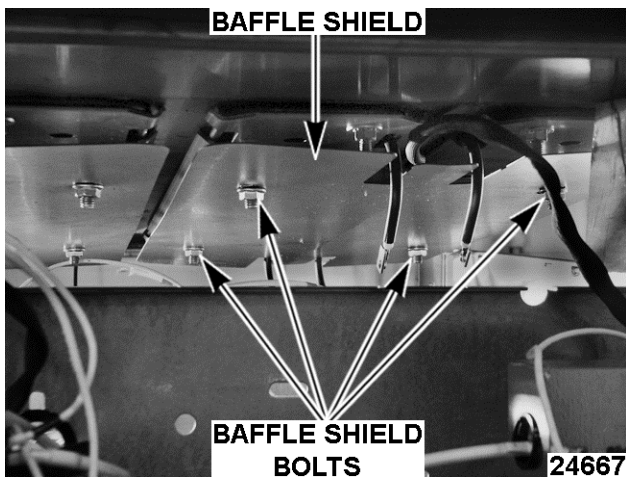

Fig. 6

4. Remove bulb clamp.

NOTE: Loosen front and rear bolts and remove thermostat probe from bulb clamp. Secure thermostat probe to prevent damage.

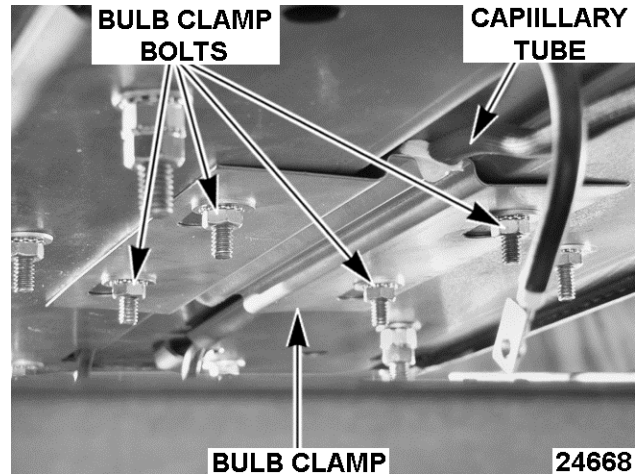

Fig. 7

5. Remove heater element jumper wire on the back heater element connections.

NOTICE When removing heater element jumper wire screw, support heater element. Refer to figure 24666.

6. Remove heating element pressure plate.

NOTE: Heater element is held into place by the pressure plate.

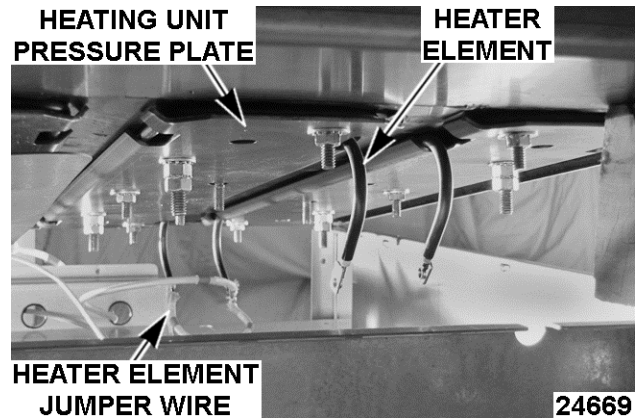

Fig. 8

7. Reverse procedures to install.

NOTE: Nuts should be torqued to 30-35 Inch Pounds.

8. See THERMOSTAT REPLACEMENT for proper installation of the thermostat.

NOTE: Coat threaded studs with high temperature anti-seize compound prior to putting bolts back on.

NOTE: Tighten nuts to 30-35 inch-pounds.

NOTICE Over tightening the nuts can cause damage and prevent the element from moving with expansion and contraction that can lead to premature failures.

9. Check for proper operation.

THERMOSTAT REPLACEMENT



WARNING Disconnect the electrical power to the machine and follow lockout / tagout procedures.

WARNING Griddle plate might be hot.

Capillary Tube Removal

1. Place griddle plate into GRIDDLE SERVICE POSITION.
2. Remove front heater element jumper wire connection.

HEATING ELEMENT JUMPER WIRE

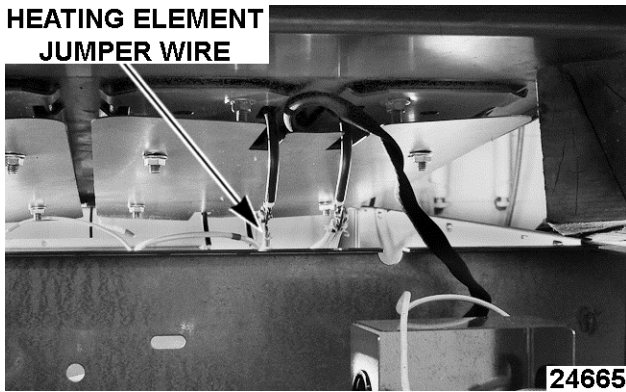

Fig. 9

NOTICE When removing heater element jumper wire screw, support heater element.

HEATER ELEMENT WIRE SCREW

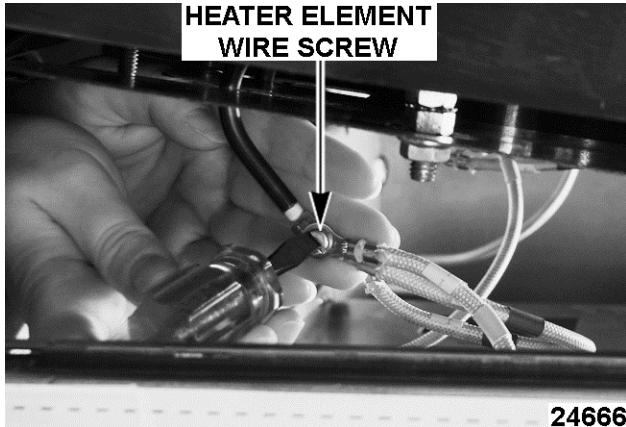

Fig. 10

3. Remove heater element baffle shield.

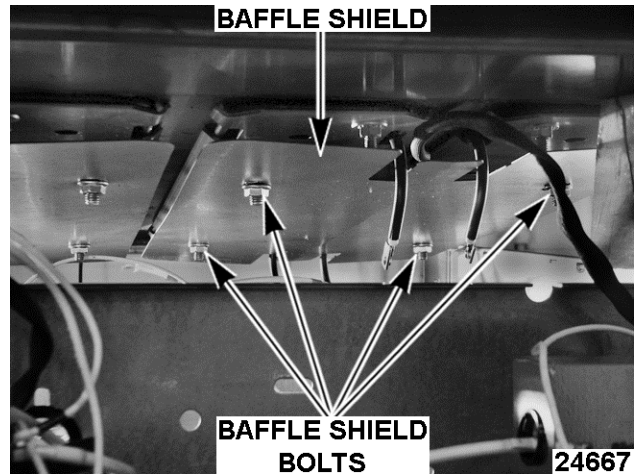

Fig. 11

4. Loosen back bolts to bulb clamp.
5. Remove front bolts to bulb clamp.

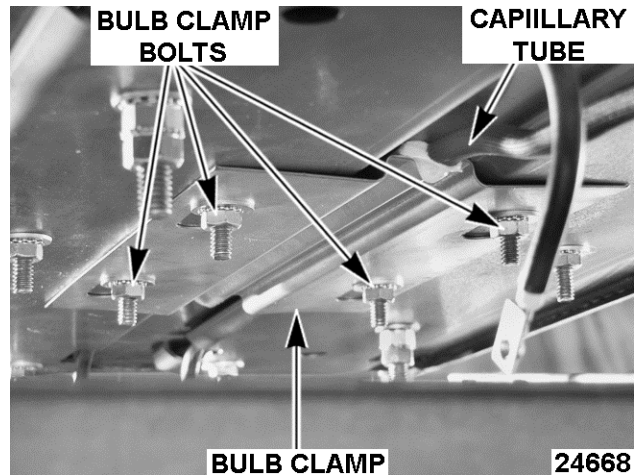

Fig. 12

6. Pull thermostat probe to remove.

NOTE: Retain capillary sleeve for new thermostat.

Thermostat Control Removal

1. Remove thermostat connection screws.

NOTE: Note heater element wire locations on the thermostat connection tabs.

2. Remove thermostat mounting screws.

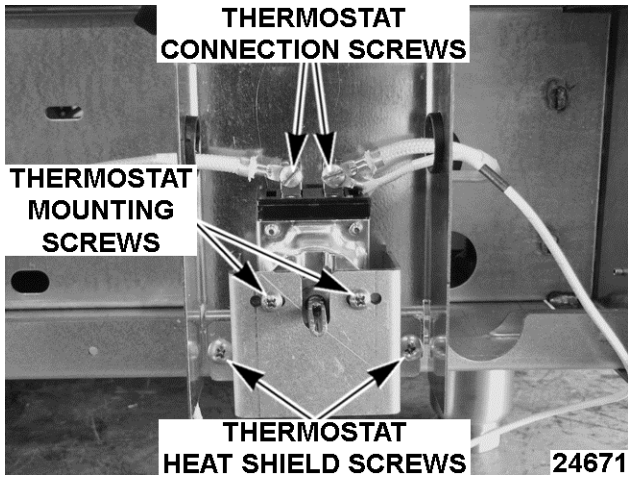

Fig. 13

3. Remove thermostat heat shield screws.
4. Remove thermostat assembly from unit.

Thermostat Control Installation

1. Install capillary sleeve on replacement thermostat.
2. Install thermostat to thermostat bracket using mounting screws.
3. Thread capillary tube through opening located on the thermostat heat shield.

NOTICE Secure thermostat capillary tube to prevent damage, while installing thermostat.

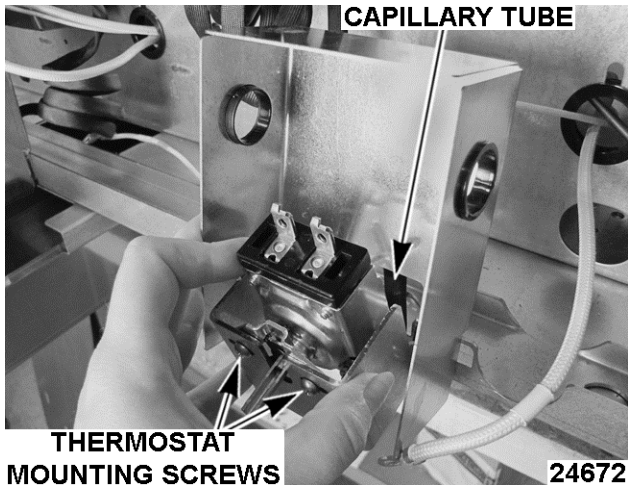

Fig. 14

4. Install thermostat bracket with the thermostat heat shield to the unit.
5. Connect heater wires to the thermostat per the wire connections noted earlier.

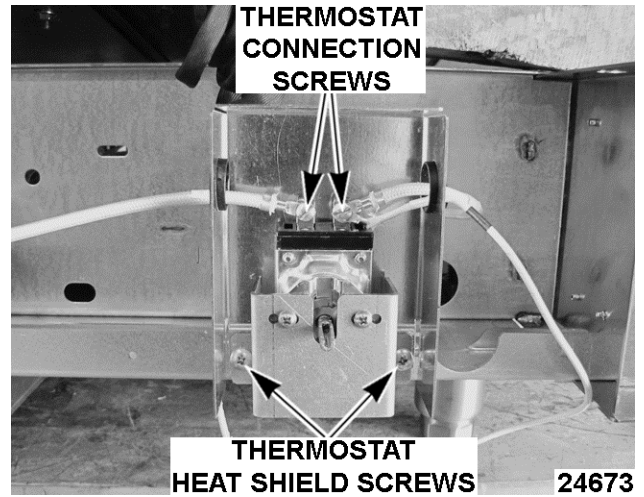

Fig. 15

Capillary Tube Installation

1. Slide capillary tube between bulb clamp and bottom of griddle plate.

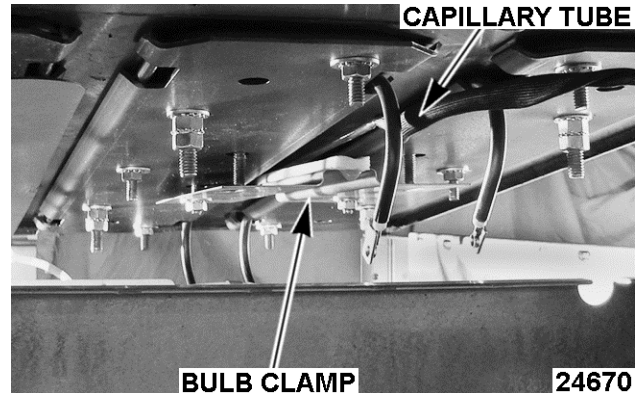

Fig. 16

NOTE: Verify capillary tube is flush against the bottom of the griddle plate.

2. Tighten bolts. Torque to 30-35 inch pounds.
3. Install baffle shield using HEATING ELEMENT REPLACEMENT instructions.
4. Check for proper operation.

SERVICE PROCEDURES AND ADJUSTMENTS

THERMOSTAT CALIBRATION PROCEDURES

1. Clean temperature test section that is not working. Center temperature tester surface mount probe in center of thermostat probe. See table for proper testing locations according to griddle size.

NOTE: All readings taken 12" from front of griddle.

Griddle Size	Distance(s) From Left Edge of Griddle
24"	6", 18"
36"	6", 18", 30"
48"	6", 18", 30", 42"
60"	6", 18", 30", 42", 54"
72"	6", 18", 30", 42", 54", 66"

2. Set the thermostat to a temperature above 300°F.
3. Allow the thermostat to cycle three times.
4. Note the tester reading when the indicator light turns ON and OFF.

NOTE: If the difference between the ON and OFF temperatures is greater than 25°F, replace the thermostat.

5. Add these two temperatures together, then divide the sum by 2 to obtain an average temperature.
 - A. If the average temperature is within 15°F of the set temperature, the thermostat is calibrated.
 - B. If the average temperature is not within 15°F of the set temperature:
 - 1) Remove thermostat knob.
 - 2) Insert a flathead screwdriver into thermostat dial stem until it reaches the calibration screw.

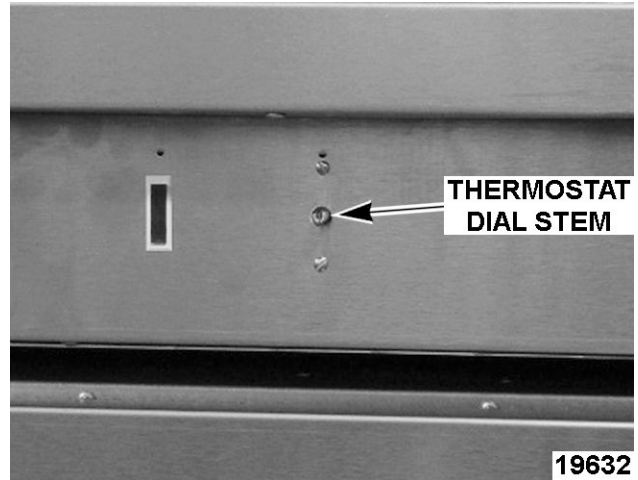
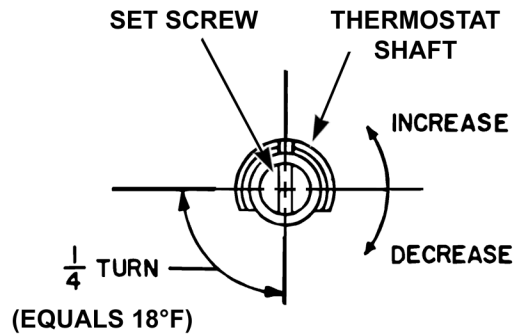

Fig. 17

- 3) Turn adjustment screw CCW to increase and CW to decrease temperature.



7842

Fig. 18

NOTE: A 1/4 turn equals 18°F change.

6. Replace knob and repeat steps 3 and 5 until average temperature is within 15°F of set temperature.
7. Reseal adjustment screw to prevent movement.

NOTE: Finger nail polish can be used to reseal screw to prevent movement.

8. If thermostat cannot be calibrated, replace thermostat as outlined under THERMOSTAT REPLACEMENT.

TESTING VOLTAGE TO HEATER(S)



⚠ WARNING Disconnect the electrical power to the machine and follow lockout / tagout procedures.

1. Test supply voltage to verify it is correct.
2. Turn power off to griddle.
3. Place griddle into GRIDDLE SERVICE POSITION.
4. Connect voltmeter to leads of heating element in question.
5. Set meter on the appropriate range, determined by line voltage rating stamped on griddle data plate.
6. Turn on electrical power.
7. Turn thermostat to 350°F.
 - A. Pilot light will energize.
8. Reading should agree with the voltage rating stamped on the griddle data plate.
 - A. If voltage reading is incorrect, and the line voltage is correct, the thermostat is not functioning properly.
 - B. If current draw is correct, then heating element is functioning properly. See table below for proper values.

VOLTS	COLOR CODE	POWER	AMP	RESISTANCE
208	YELLOW	2.7kW	13	16
240	RED	2.7kW	11.3	21.3
480	GREEN	2.7kW	5.6	85.7
NOTES:	1. Values in table are nominal. Tolerance is +5/-10%. 2. Resistance values (ohms) are @ 77°F room temperature.			

ELECTRICAL OPERATION

PROCEDURE OF OPERATION

1. Refer to the schematic in the appropriate electrical diagram at the end of this section to trace circuits explained in this section.
2. The electrical connection(s) to the griddle are made in the junction box.
 - A. Detailed information about the electrical connections to the griddle is contained in the "Installation and Owners Manual".
3. From the junction box, one electrical connection is made to the thermostat. The other electrical connection is made to the common side of the two heating elements which the thermostat controls.
4. With the dial set to "OFF", the thermostat contacts are open.
5. Turn dial to 350°F.
 - A. The thermostat contacts close, electrical power is applied to the heating elements, the griddle begins to heat.
 - B. The indicator light energizes.
6. When the griddle surface reaches 350°F, the thermostat contacts open and electrical power is removed from the heating elements.
 - A. The indicator light de-energizes.
7. The thermostat will cycle the heating elements and indicator light to maintain the griddle temperature.

24" WIRING DIAGRAM

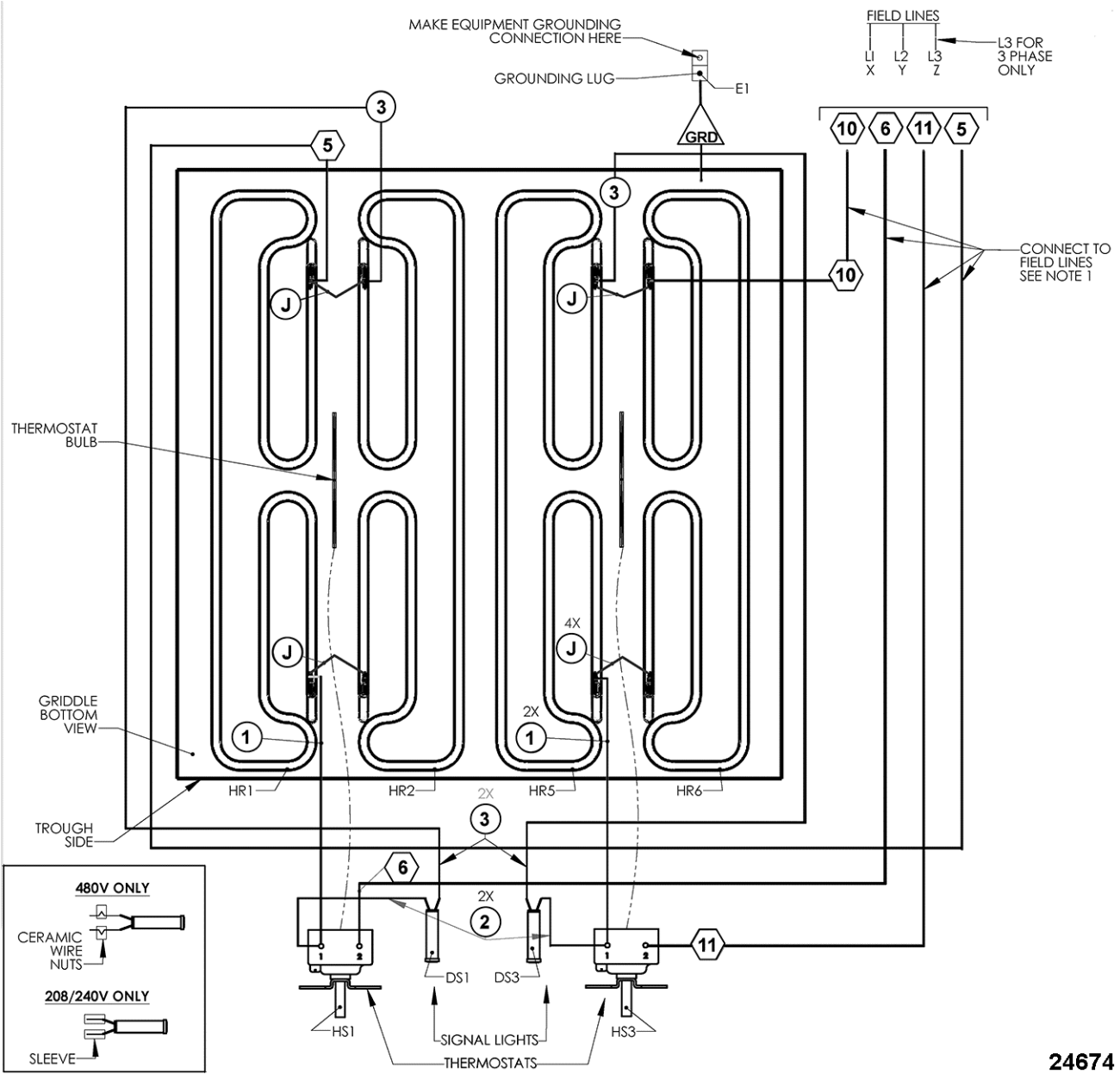

24674

24" WIRING DIAGRAM

Notes:

1. For supply connections, use copper wire sized in accordance with the national electrical code and suitable for at least 90°C (194°F).
2. Lead marker numbers are the same as lead item numbers unless otherwise specified.
3. Wiring to be:
 - A. **10G,m 532515** - leads 1, 5, 6, 10, 11, J and GRD.
 - B. **18GA., 532518** - leads 2 and 3.

24" SCHEMATIC

1 & 3 PHASE

208, 240, & 480 VAC, 1 & 3 PHASE				
	X-Y	Y-Z	X-Z	TOTAL
KW PER LINE	5.4	5.4	0.0	10.8

NOMINAL AMPS PER LINE				
	3-PHASE			1-PHASE
	X	Y	Z	-
208	22.5	45.0	22.5	51.9
240	19.5	39.0	19.5	45.0
480	9.7	19.5	9.7	22.5

FOR 3-PHASE:

1. Connect wire #5 to L1.
2. Connect wire #6 & #11 to L2.
3. Connect wire #10 to L3.

FOR 1-PHASE:

1. Connect wire #5 & #10 to L1.
2. Connect wire #6 & #11 to L2.

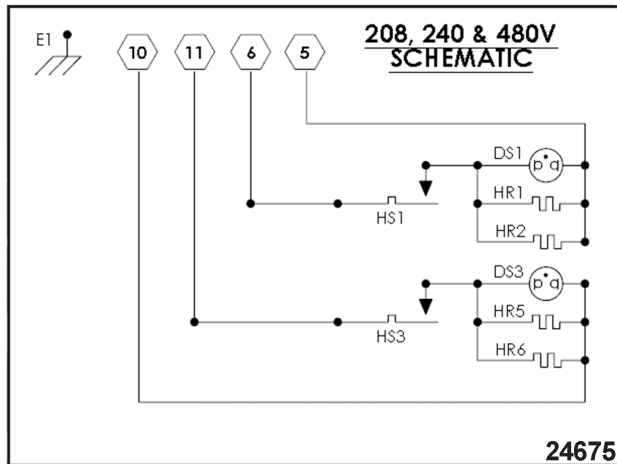

1 & 3 PHASE

2 PHASE, 3 WIRE

220/380 & 240/415 VAC. 2-PHASE, 3 WIRE			
	L1-N	L2-N	L3-N
KW PER LINE	5.4	5.4	0.0

NOMINAL AMPS PER LINE					
	L1	L2	L3	N	TOTAL kW
220/380	5.2	5.2	0.0	3.4	9.1
240/415	5.6	5.6	0.0	3.8	10.8

FOR 2-PHASE, 3 WIRE:

1. Connect wire #5 & #10 to neutral ("N").
2. Connect wire #11 to L1.
3. Connect wire #6 to L2.

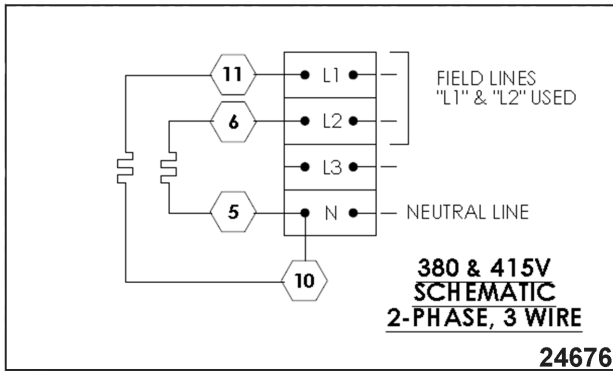

2 PHASE, 3 WIRE

36" WIRING DIAGRAM

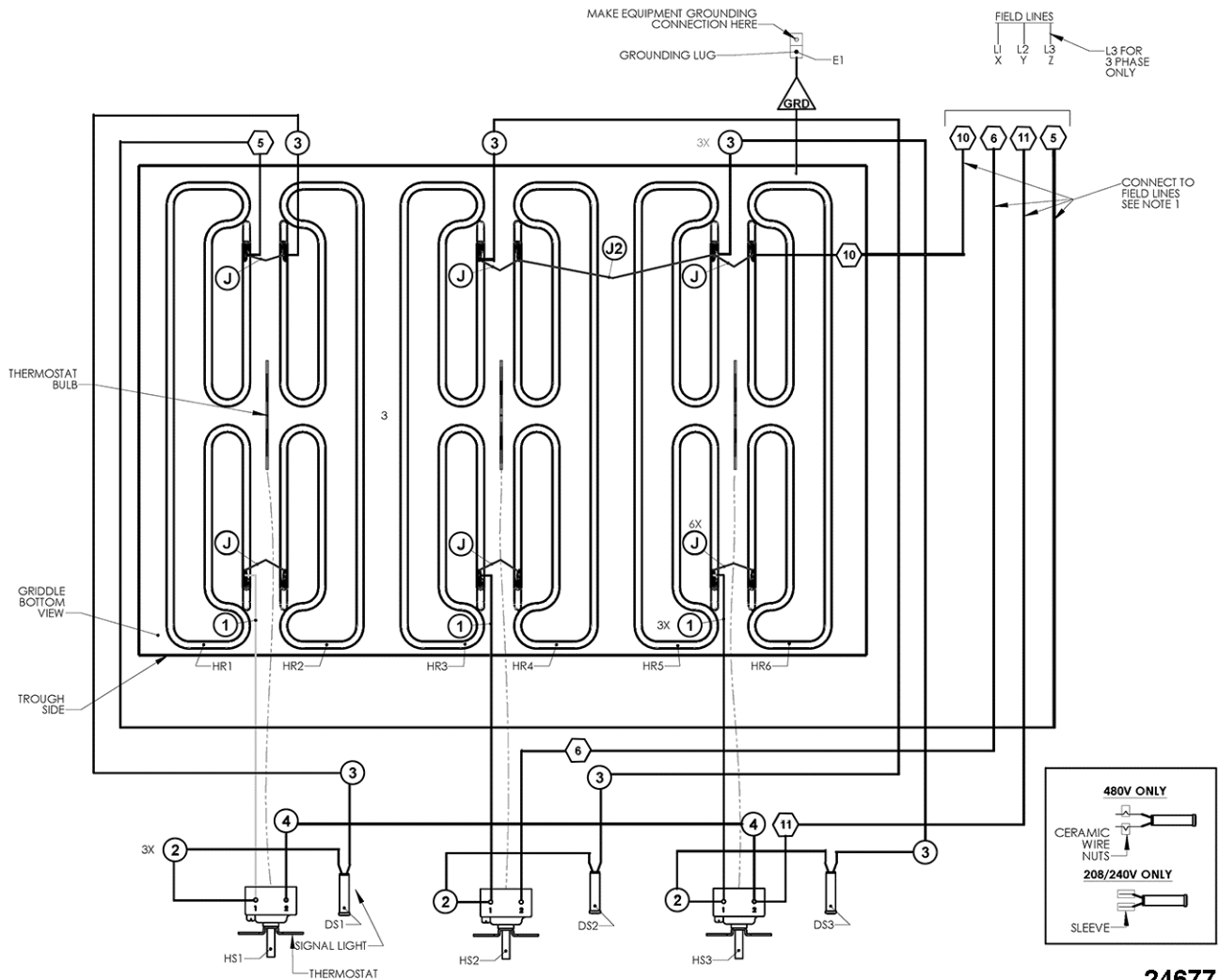

24677

Notes:

1. For supply connections, use copper wire sized in accordance with the national electrical code and suitable for at least 90°C (194°F).
2. Lead marker numbers are the same as lead item numbers unless otherwise specified.
3. Wiring to be:
 - A. **10G,m 532515** - leads 1, 4 - 6, 10, 11, J, J2 and GRD.
 - B. **18GA., 532518** - leads 2 and 3.

36" SCHEMATIC

1 & 3 PHASE

208, 240, & 480 VAC, 1 & 3 PHASE				
	X-Y	Y-Z	X-Z	TOTAL
KW PER LINE	5.4	5.4	5.4	16.2

NOMINAL AMPS PER LINE				
	3-PHASE			1-PHASE
	X	Y	Z	-
208	45.0	45.0	45.0	77.9
240	39.0	39.0	39.0	67.5
480	19.5	19.5	19.5	33.8

FOR 3-PHASE:

1. Connect wire #10 to L1.
2. Connect wire #11 to L2.
3. Connect wire #5 & #6 to L3.

FOR 1-PHASE:

1. Connect wire #5 & #10 to L1.
2. Connect wire #6 & #11 to L2.

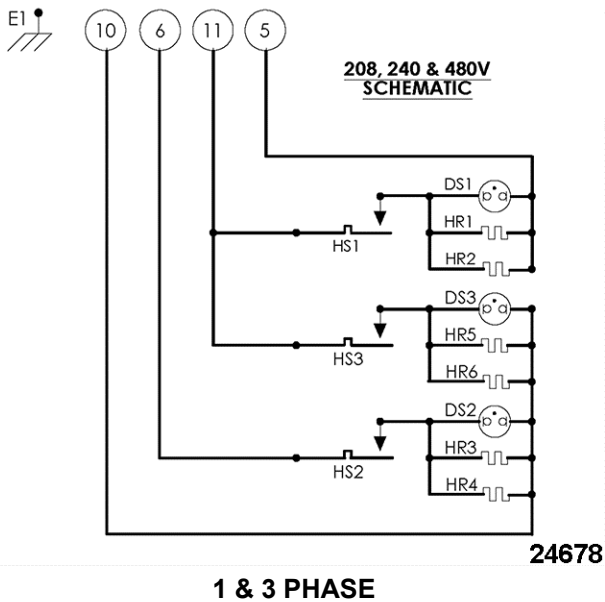

2 PHASE, 3 WIRE

220/380 & 240/415 VAC. 2-PHASE, 3 WIRE			
	L1-N	L2-N	L3-N
KW PER LINE	5.4	10.8	0.0

NOMINAL AMPS PER LINE					
	L1	L2	L3	N	TOTAL kW
220/380	6.9	6.9	0.0	4.6	13.6
240/415	7.5	7.5	0.0	5.0	16.2

FOR 2-PHASE, 3 WIRE:

1. Connect wire #5 & #10 to neutral ("N").
2. Connect wire #6 to L1.
3. Connect wire #11 to L2.

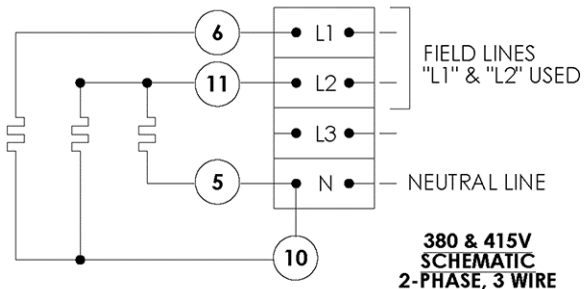

**380 & 415V
SCHEMATIC
2-PHASE, 3 WIRE**

24679

2 PHASE, 3 WIRE

48" WIRING DIAGRAM

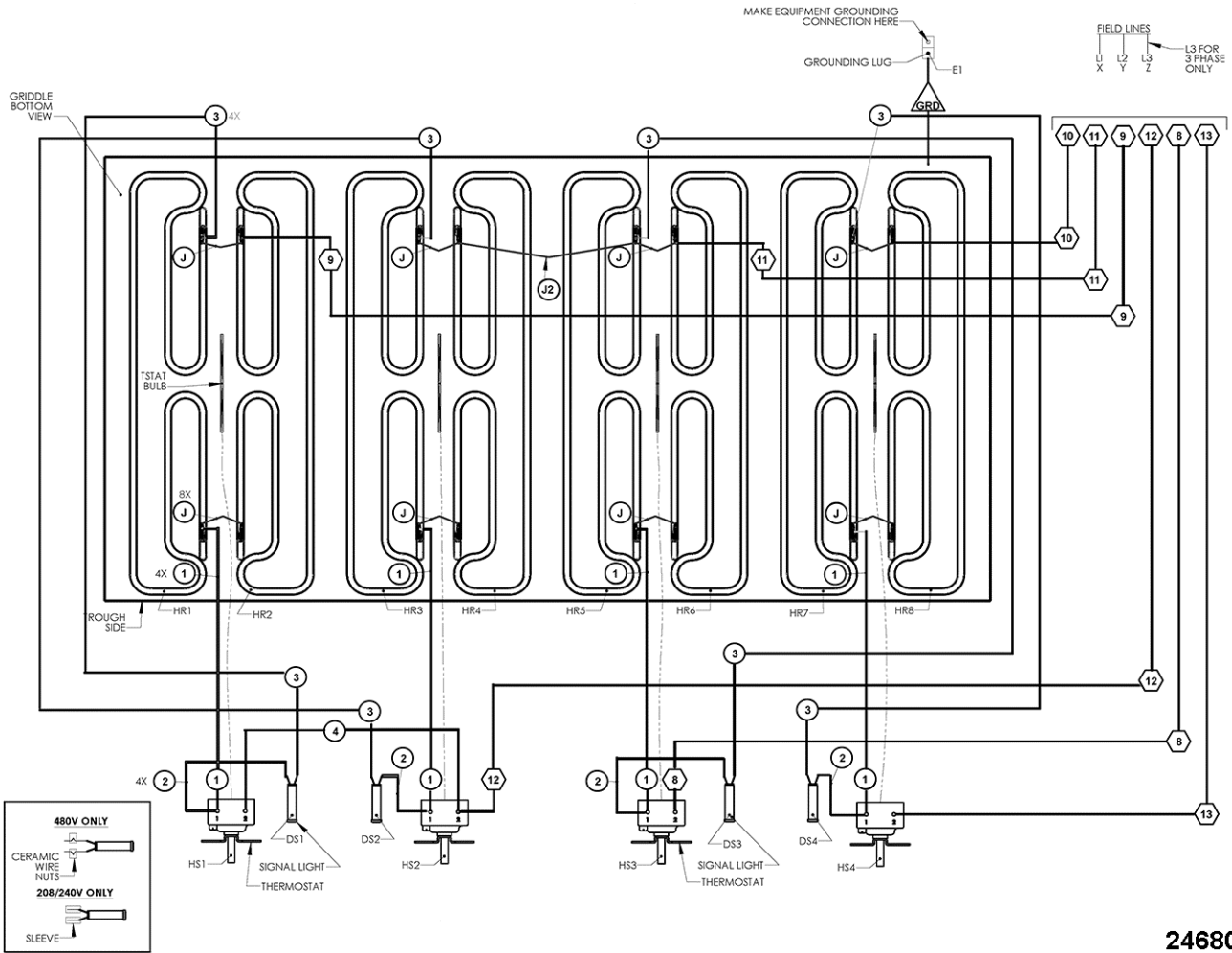

48" WIRING DIAGRAM

Notes:

1. For supply connections, use copper wire sized in accordance with the national electrical code and suitable for at least 90°C (194°F).
2. Lead marker numbers are the same as lead item numbers unless otherwise specified.
3. Wiring to be:
 - A. **10G,m 532515** - leads 1, 4, 8 - 13, J, J2 and GRD.
 - B. **18GA., 532518** - leads 2 and 3.

48" SCHEMATIC

1 & 3 PHASE

208, 240, & 480 VAC, 1 & 3 PHASE				
	X-Y	Y-Z	X-Z	TOTAL
kW PER LINE	10.8	5.4	5.4	21.6

NOMINAL AMPS PER LINE				
	3-PHASE			1-PHASE
	X	Y	Z	-
208	67.4	67.4	45.0	103.8
240	58.5	58.5	39.0	90.0
480	29.2	29.2	19.5	45.0

FOR 3-PHASE:

1. Connect wire #10 & #11 to L1.
2. Connect wire #8, #9 & #13 to L2.
3. Connect wire #12 to L3.

FOR 1-PHASE:

1. Connect wire #8, #12 & #13 to L1.
2. Connect wire #9, #10 & #11 to L2.

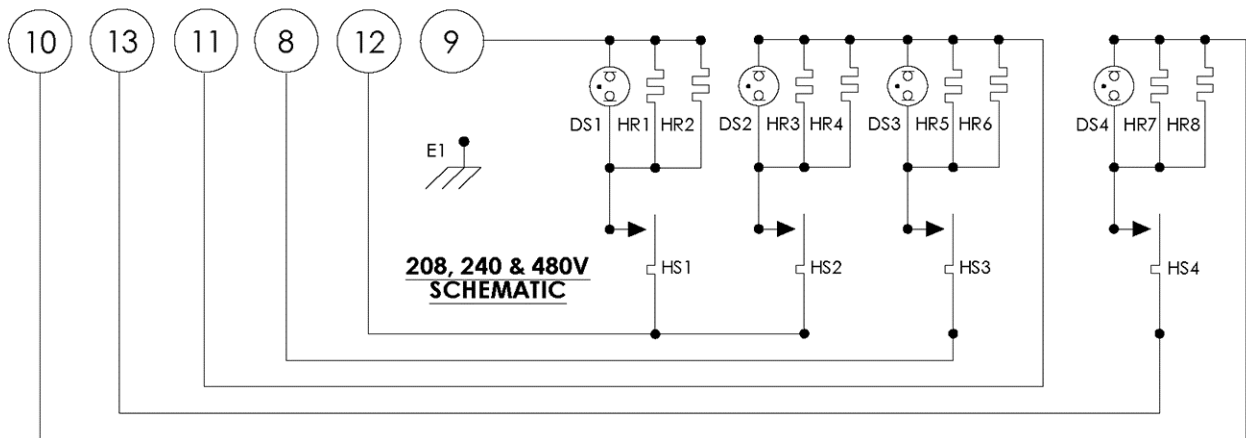

24681

1 & 3 PHASE

3 PHASE, 4 WIRE

220/380 & 240/415 VAC. 3-PHASE, 4 WIRE			
	L1-N	L2-N	L3-N
kW PER LINE	10.8	5.4	5.4

NOMINAL AMPS PER LINE					
	L1	L2	L3	N	TOTAL kW
220/380	13.8	12.0	12.0	3.7	18.2

NOMINAL AMPS PER LINE					
	L1	L2	L3	N	TOTAL kW
240/415	15.0	13.1	13.1	4.0	21.6

FOR 3-PHASE, 4 WIRE:

1. Connect wire #9, #10 & #11 to neutral ("N").
2. Connect wire #12 to L1.
3. Connect wire #8 to L2.
4. Connect wire #13 to L3.

**380 & 415V
SCHEMATIC
3-PHASE, 4 WIRE**

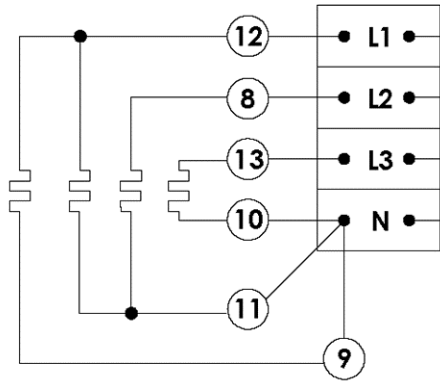

24682

3-PHASE, 4 WIRE

60" WIRING DIAGRAM

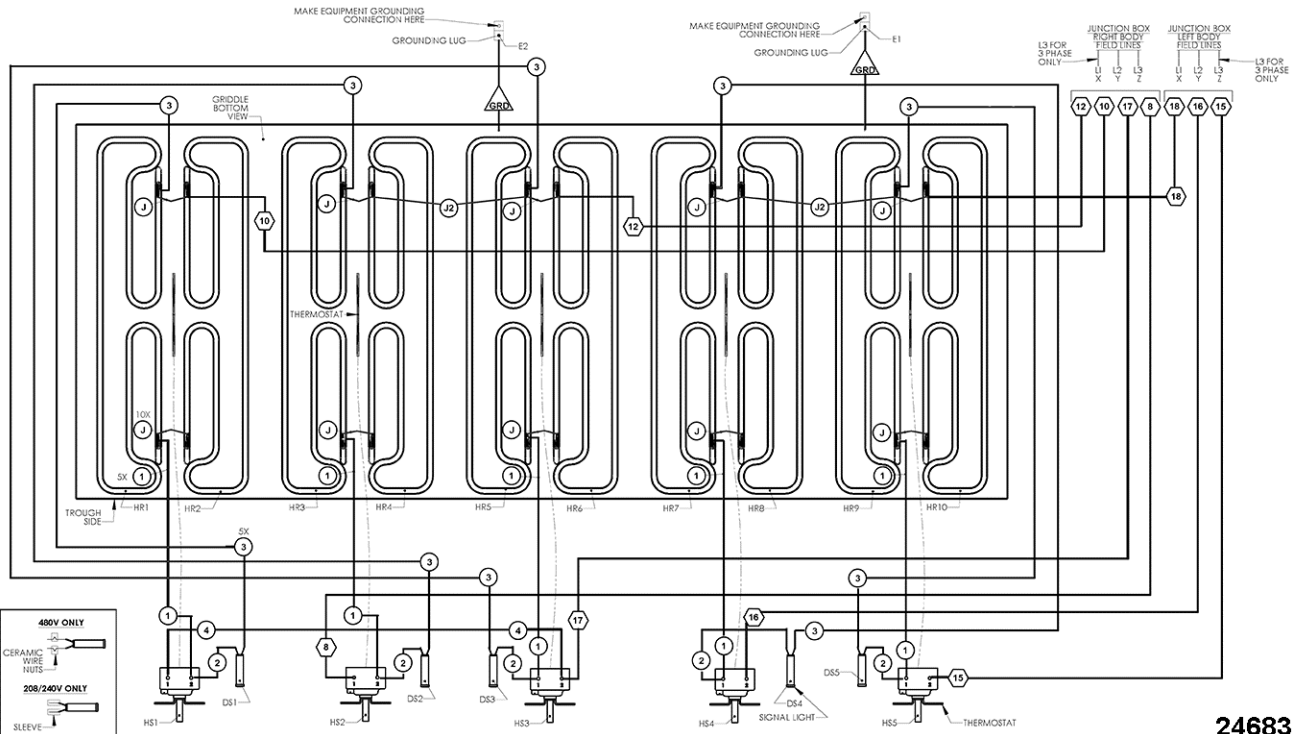

24683

60" WIRING DIAGRAM

Notes:

1. For supply connections, use copper wire sized in accordance with the national electrical code and suitable for at least 90°C (194°F).
2. **SERVICING ONLY**
Each half of this griddle is wired separately and terminates in its own junction box. Each junction box requires a separate fused branch circuit power supply as the griddle is not fused. Both power sources have to be disconnected before servicing the device.
3. Lead marker numbers are the same as lead item numbers unless otherwise specified.
4. Wiring to be:
 - A. **10G,m 532515** - leads 1, 4, 8, 10, 12, 15 - 18, J, J2 and GRD.
 - B. **18GA., 532518** - leads 2 and 3.

60" SCHEMATIC

1 & 3 PHASE

208, 240, & 480 VAC, 1 & 3 PHASE					
		X-Y	Y-Z	X-Z	TOTAL
KW PER LINE	LEFT	5.4	0	5.4	10.8
	RIGHT	5.4	5.4	5.4	16.2

NOMINAL AMPS PER LINE					
		3-PHASE			1-PHASE
		X	Y	Z	-
208	LEFT	45.0	22.5	22.5	51.9
	RIGHT	45.0	45.0	45.0	77.9
240	LEFT	39.0	19.5	19.5	45.0
	RIGHT	39.0	39.0	39.0	67.5
480	LEFT	19.5	9.7	9.7	22.5
	RIGHT	19.5	19.5	19.5	33.8

LEFT JUNCTION BOX PHASE WIRING:

FOR 3-PHASE:

1. Connect wire #18 to L1.
2. Connect wire #16 to L2.
3. Connect wire #15 to L3.

FOR 1-PHASE:

1. Connect wire #15 & #16 to L1.
2. Connect wire #18 to L2.

RIGHT JUNCTION BOX PHASE WIRING:

FOR 3-PHASE:

1. Connect wire #8 & #10 to L1.
2. Connect wire #17 to L2.
3. Connect wire #12 to L3.

FOR 1-PHASE:

1. Connect wire #10 & #12 to L1.
2. Connect wire #8 & #17 to L2.

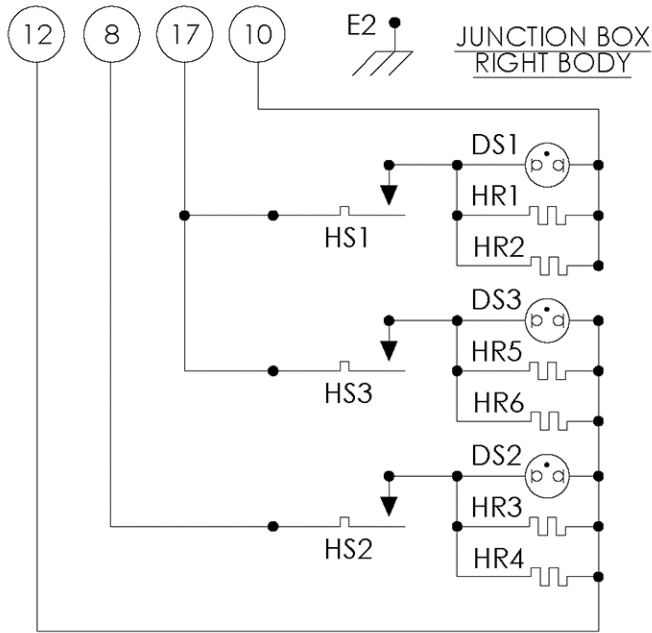

**208, 240 & 480V
SCHEMATIC**

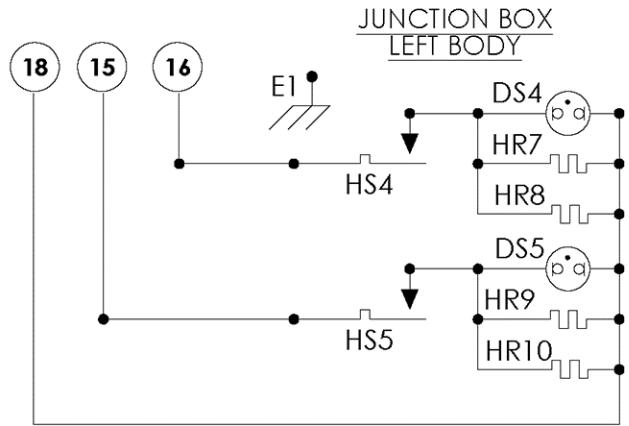

24684

1 & 3 PHASE

2 PHASE, 3 WIRE

220/380 & 240/415 VAC. 2-PHASE, 3 WIRE				
		L1-N	L2-N	L3-N
kW PER LINE	LEFT	5.4	5.4	0.0
	RIGHT	5.4	10.8	0.0

NOMINAL AMPS PER LINE						
		L1	L2	L3	N	TOTAL kW
220/380	LEFT	5.2	5.2	0.0	3.4	9.1
	RIGHT	6.9	6.9	0.0	4.6	13.6
240/415	LEFT	5.6	5.6	0.0	3.8	10.8
	RIGHT	7.5	7.5	0.0	5.0	16.2

LEFT JUNCTION BOX PHASE WIRING

1. Connect wire #18 to neutral (N).
2. Connect wire #16 to L1.
3. Connect wire #15 to L2.

RIGHT JUNCTION BOX PHASE WIRING

1. Connect wire #8 & #10 to neutral (N).
2. Connect wire #12 to L1.
3. Connect wire #17 to L2.

**380 & 415V SCHEMATIC
2-PHASE, 3 WIRE**

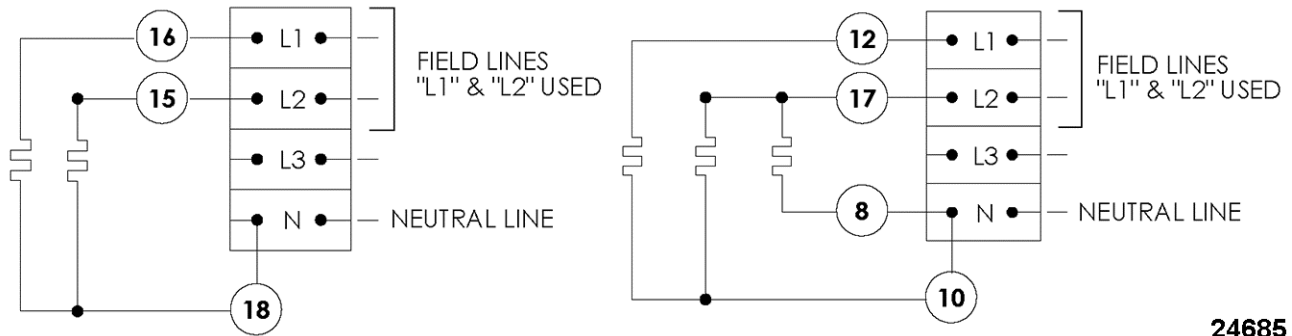

24685

2-PHASE, 3 WIRE

72" WIRING DIAGRAM

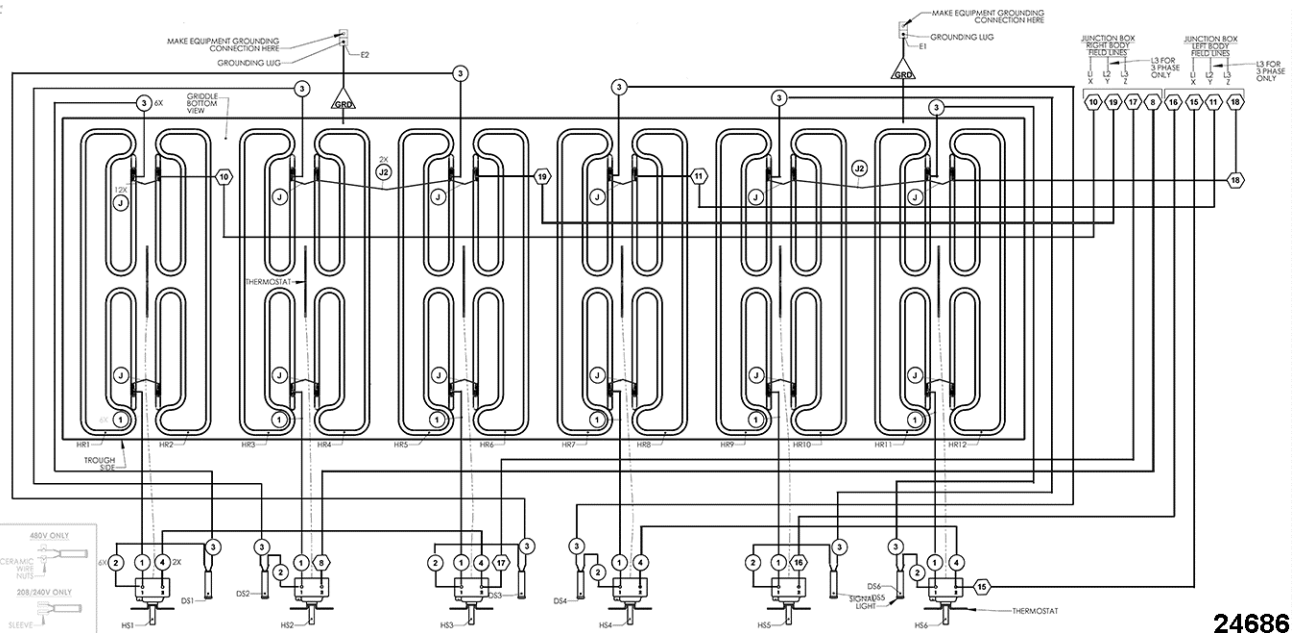

24686

72" WIRING DIAGRAM

Notes:

1. For supply connections, use copper wire sized in accordance with the national electrical code and suitable for at least 90°C (194°F).
2. **SERVICING ONLY**
Each half of this griddle is wired separately and terminates in its own junction box. Each junction box requires a separate fused branch circuit power supply as the griddle is not fused. Both power sources have to be disconnected before servicing the device.
3. Lead marker numbers are the same as lead item numbers unless otherwise specified.
4. Wiring to be:
 - A. **10G,m 532515** - leads 1, 4, 8, 10, 11, 15 - 19, J, J2 and GRD.
 - B. **18GA., 532518** - leads 2 and 3.

72" SCHEMATIC

1 & 3 PHASE

208, 240, & 480 VAC, 1 & 3 PHASE					
		X-Y	Y-Z	X-Z	TOTAL
KW PER LINE	LEFT	5.4	5.4	5.4	16.2
	RIGHT	5.4	5.4	5.4	16.2

NOMINAL AMPS PER LINE					
		3-PHASE			1-PHASE
		X	Y	Z	-
208	LEFT	45.0	45.0	45.0	77.9
	RIGHT	45.0	45.0	45.0	77.9
240	LEFT	39.0	39.0	39.0	67.5
	RIGHT	39.0	39.0	39.0	67.5
480	LEFT	19.5	19.5	19.5	33.8
	RIGHT	19.5	19.5	19.5	33.8

LEFT JUNCTION BOX PHASE WIRING:

FOR 3-PHASE:

1. Connect wire #16 & #11 to L1.
2. Connect wire #15 to L2.
3. Connect wire #18 to L3.

FOR 1-PHASE:

1. Connect wire #11 & #18 to L1.
2. Connect wire #16 & #15 to L2.

RIGHT JUNCTION BOX PHASE WIRING:

FOR 3-PHASE:

1. Connect wire #8 & #10 to L1.
2. Connect wire #17 to L2.
3. Connect wire #19 to L3.

FOR 1-PHASE:

1. Connect wire #10 & #19 to L1.
2. Connect wire #8 & #17 to L2.

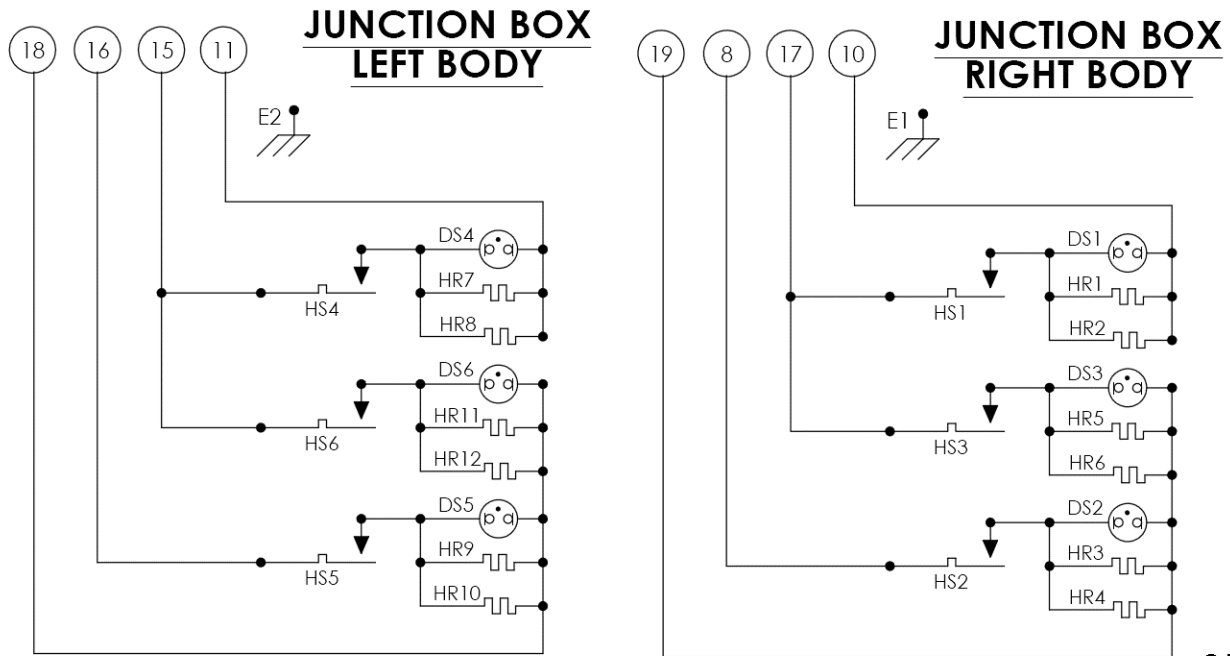

24687

1 & 3 PHASE

2 PHASE, 3 WIRE

220/380 & 240/415 VAC. 2-PHASE, 3 WIRE				
		L1-N	L2-N	L3-N
kW PER LINE	LEFT	5.4	10.8	0.0
	RIGHT	5.4	10.8	0.0

NOMINAL AMPS PER LINE						
		L1	L2	L3	N	TOTAL kW
220/380	LEFT	6.9	6.9	0.0	4.6	13.6
	RIGHT	6.9	6.9	0.0	4.6	13.6
240/415	LEFT	7.5	7.5	0.0	5.0	16.2
	RIGHT	7.5	7.5	0.0	5.0	16.2

LEFT JUNCTION BOX PHASE WIRING

1. Connect wire #11 & #18 to neutral (N).
2. Connect wire #16 to L1.
3. Connect wire #15 to L2.

RIGHT JUNCTION BOX PHASE WIRING

1. Connect wire #19 & #10 to neutral (N).
2. Connect wire #8 to L1.
3. Connect wire #17 to L2.

**380 & 415V SCHEMATIC
2-PHASE, 3 WIRE**

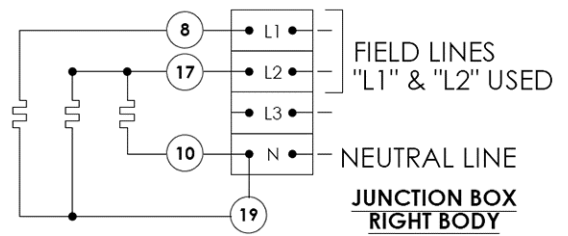
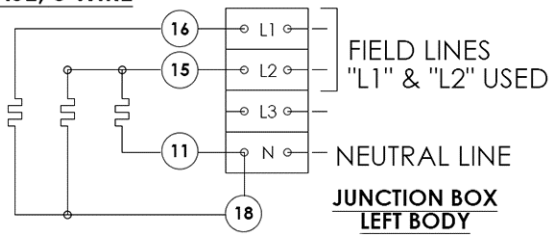

24688

2-PHASE, 3 WIRE

TROUBLESHOOTING

TROUBLESHOOTING

Troubleshooting Guide	
PROBLEM	POSSIBLE CAUSES
Heat does not come on when the temperature controller is turned on.	<ol style="list-style-type: none"> 1. Main power supply disconnected. 2. Problem with thermostats. Refer to <u>THERMOSTAT REPLACEMENT</u>. 3. Problem with heating elements. Refer to <u>HEATING ELEMENT REPLACEMENT</u>.
Fat appears to smoke excessively.	<ol style="list-style-type: none"> 1. Temperature set too high. 2. Moisture in food may be turning into steam.
Food sticks to griddle or burned around edges or contains dark specs.	<ol style="list-style-type: none"> 1. Temperature set too high. 2. Griddle surface requires cleaning and/or seasoning. 3. Surface under food not covered with enough cooking oil.
Food under-cooked inside.	<ol style="list-style-type: none"> 1. Temperature set too low. 2. Food not cooked for long enough time.
Food tastes greasy or has objectionable off-flavor.	<ol style="list-style-type: none"> 1. Food itself may have off-flavor. 2. Food stored improperly before cooking. 3. Too much griddle fat used. 4. Temperature set too low.
Noticeable build-up of gum on griddle.	<ol style="list-style-type: none"> 1. Temperature set too high. 2. Griddle surface needs cleaning and/or seasoning. 3. Too much griddle fat used.
Griddle does not heat. (Indicator light does not glow).	<ol style="list-style-type: none"> 1. No power to the machine. Circuit breaker tripped. 2. Thermostat inoperative. Refer to <u>THERMOSTAT REPLACEMENT</u>.
Griddle does not heat. (Indicator light glows).	Heating element(s) inoperative. Refer to <u>HEATING ELEMENT REPLACEMENT</u> .
Hot and cold spots controlled by the same thermostat.	<ol style="list-style-type: none"> 1. Uneven loading patterns. 2. Heating element(s) not clamped tight to griddle plate. Refer to <u>HEATING ELEMENT REPLACEMENT</u>. 3. Different voltage heating elements. 4. Heating elements inoperative. Refer to <u>HEATING ELEMENT REPLACEMENT</u>. 5. Air drafts on griddle plate.

Troubleshooting Guide	
PROBLEM	POSSIBLE CAUSES
Too hot in area controlled by the same thermostat.	<ol style="list-style-type: none"> 1. Incorrect voltage supply. 2. Thermostat bulb not clamped tight to griddle plate. Refer to <u>CAPILLARY BULB INSTALLATION</u>. 3. Thermostat not calibrated correctly. Refer to <u>THERMOSTAT CALIBRATION PROCEDURES</u>.
Too cold in area controlled by the same thermostat.	<ol style="list-style-type: none"> 1. Incorrect voltage supply. 2. Thermostat not calibrated correctly. Refer to <u>THERMOSTAT CALIBRATION PROCEDURES</u>.