

American Dish Service

ADS MODEL ASQ GLASSWASHER

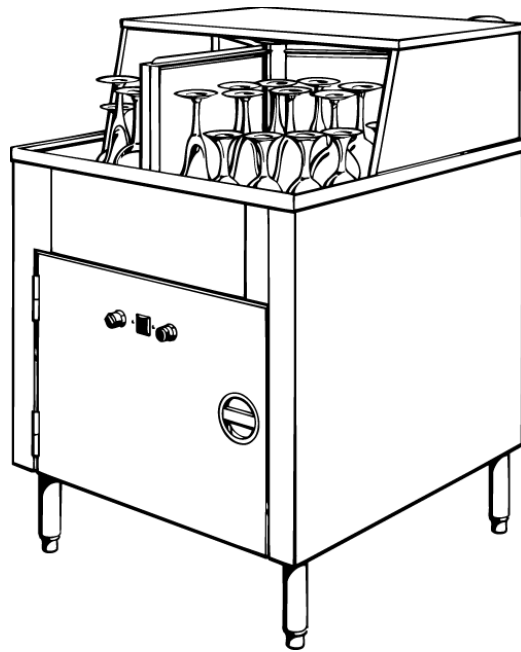

SERVICE MANUAL

900 Blake Street
Edwardsville, Kansas 66111
(913)-422-3700

IMPORTANT:

American Dish Service provides this information as a service to our customers. Keep all instructions for future reference. Although ADS will make every effort to make sure the information in this service manual is correct and up-to-date, ADS does not certify that this is the case, and should you decide to utilize this manual, you do so at your own risk. ADS reserves the right to alter or update this information at any time without notice. Should you desire to make sure that you have the most up-to-date information, we would direct you to the appropriate document on our website: www.AmericanDish.com. The instructions and guidelines in this owners manual are given with the assumption that the dishwasher has been installed, operated, and maintained properly and in accordance with all applicable Codes, Ordinances, and Safety requirements. Failure to install, operate, and maintain the machine in this manner will void the ADS Warranty. ADS assumes no liability or control over the installation, maintenance (service), or operation of the equipment. Product failure due to improper installation, maintenance, and operation is not covered under the ADS Warranty.

WARNING:

During the operation of all dishmachines, chemicals, high voltage electricity, and normal operational functions can cause harm, bodily injury, or worse if proper installation, operation, and maintenance are not observed. It is imperative that the operator(s) are trained in the operation and made aware of the hazards that can exist. This is the responsibility of the owner of this equipment. When installing, operating, or maintaining your dishwasher you must follow all applicable safety requirements, including the wearing of approved personal protective equipment.

TABLE OF CONTENTS

- 1.0 GENERAL**
- 2.0 OPERATOR PROCEDURE**
- 3.0 INSTALLATION**
- 4.0 CHEMICALS**
- 5.0 PREVENTIVE MAINTENANCE**
- 6.0 TROUBLESHOOTING**
- 7.0 REPAIR PROCEDURES**
- 8.0 REPLACEMENT PARTS**

1.0 GENERAL

The Model ASQ Glass washing machine is intended for under counter installation in bars and restaurants. The unit has a circular rack divided into three compartments. This rack is indexed manually so that one compartment is at the back of the machine in the wash zone while the other two compartments are used for loading and unloading. The machine uses liquid chemicals for sanitizing, rinse-aid and detergent.

During the first part of the cycle detergent is metered and the machine washes glasses. It then drains and pre-rinses. Fresh water continues to flow into the machine until the sump is full and the recirculating pump starts for the pumped rinse. Chlorine based sanitizing chemicals are introduced during the rinse. When the cycle is complete the rinse water remains in the machine to serve as wash water for the following load.

The rack is manually indexed bringing freshly washed glasses to the front compartment and taking soiled glassware into the wash compartment. When the cycle start button is pressed the next cycle begins.

Chemicals are stored in the front compartment accessible through the main door. Electrical controls are enclosed in a cabinet on this door for accessibility. A small heater maintains wash temperature when there are long periods between cycles.

2.0 OPERATOR PROCEDURES

2.1 DAILY START-UP

The following procedure should be followed at the beginning of each shift:

1. Inspect spray arm, screen and sump (1) for cleanliness.
2. Inspect chemical containers to insure an adequate supply for the entire shift.
3. Turn on power switch (Green) at the front of the machine.
4. Depress the fill button on the side of the control cabinet until the machine begins its cycle.
5. When the machine has finished its first cycle check the water temperature (2). If it has not reached 120° F. (49°C.) then press the cycle start button on the front of the machine (Red). Repeat this procedure until water is at the proper temperature.
6. Load the first glasses into the left hand side of the carousel. Unlatch and rotate the carousel 1/3 revolution.
7. Press the cycle start button (Red).
8. Subsequent loads of soiled glasses may be placed on the left hand side of the carousel and clean glasses may be removed from the right hand side of the carousel while the machine is in operation.

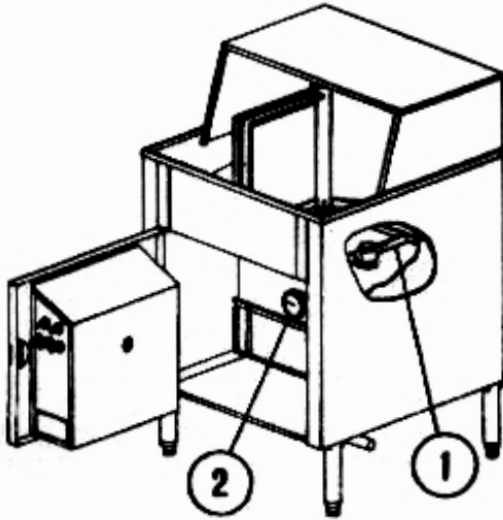

Figure 2.1.1

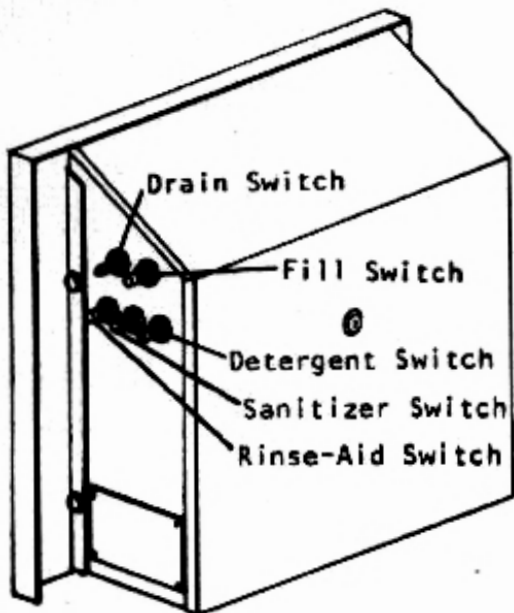

Figure 2.1.2

2.2 DAILY MAINTENANCE

At the end of his shift the operator should do the following (See Figure 2.2.1):

1. Drain water from the machine using the drain switch inside the door.
2. Remove the hood top (1) by lifting up approximately 1 inch and pulling forward.
3. Remove the carousel by lifting approximately 1 ½ inches and pulling forward.
4. Remove the splash shields (2) on either side of the carousel pivot by pulling up at the center and sliding inward.
5. Remove the spray arm (3) by lifting it off the pivot.
6. Remove the scrap screen (4) and dispose of accumulated debris.
7. Thoroughly clean the inside of the sump and drain pan as well as all removed parts.
8. Clean the spray arm.
9. Reassemble in reverse order.
10. Refill with water.

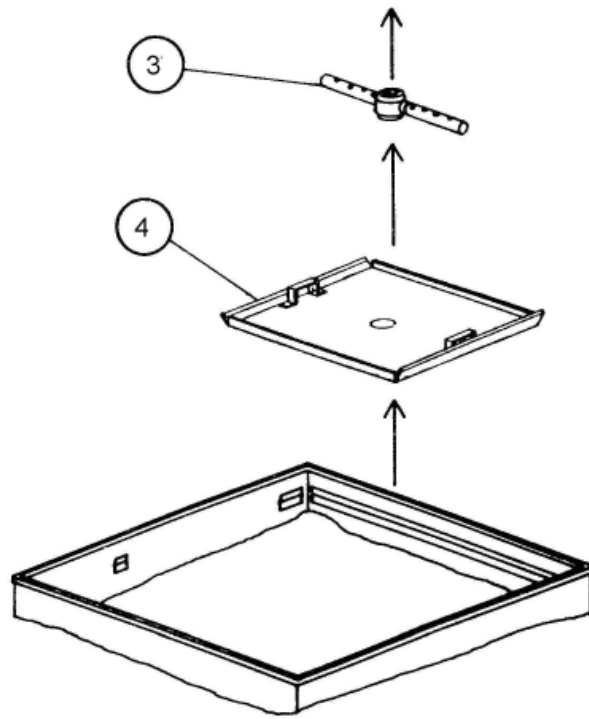
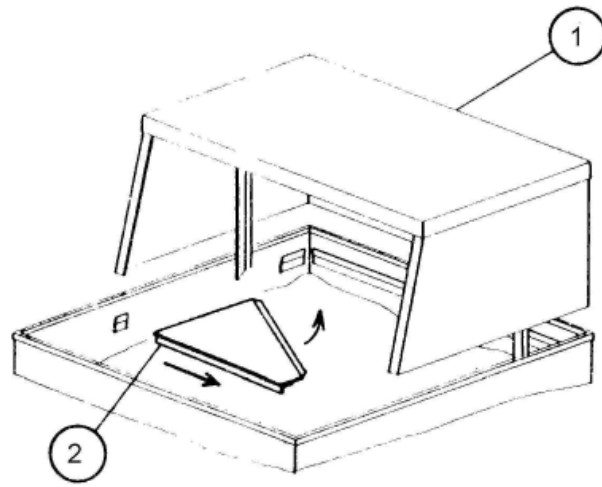

Figure 2.2.1

3.0 INSTALLATION

Adjust height and level of the machine (See Section 7.1.3).

Connect the machine (1) to a separately fused 20 amp circuit using ½ inch Sealtite. All electrical work shall conform to the current edition of the National Electric Code or to applicable local codes, whichever is most stringent. Check building wiring for proper polarity and grounding.

Connect the fresh water inlet (2) to a suitable source of hot water. Source must be capable of supplying 140° F. (60° C.) water with a recovery rate of 50 GPH.

Connect tail piece (3) to drain.

Place chemical suction tubes in their proper containers.

RED – DETERGENT
GREEN – SANITIZER
BLUE – RINSE-AID

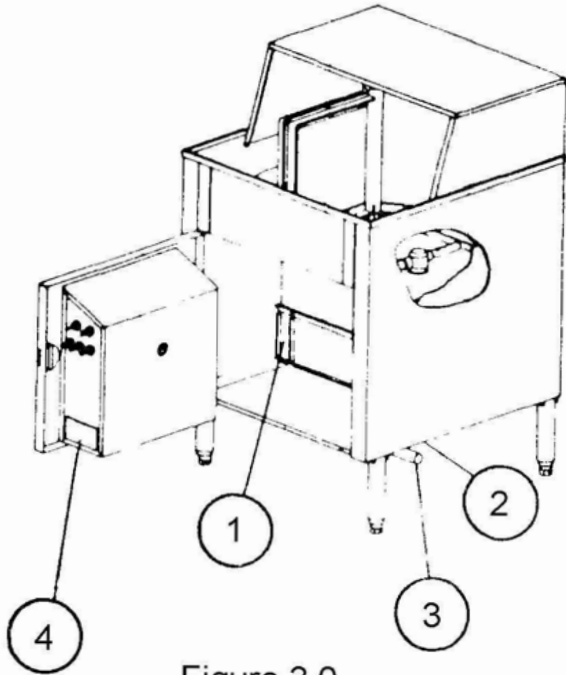

Figure 3.0

3.1 START-UP

Perform the following start-up procedures. This should be done by a qualified service representative.

1. Check voltage rating on name plate (4) and confirm that electrical supply is correct.
2. Visually inspect machine for defects, shipping damage or improper installation.
3. Prime chemical pumps (See Figure 2.1.2).

4. Adjust chemical pump delivery in accordance with the recommendations of Section 4.0 and 7.4.3.
5. Fill and operate machine. Insure that water level is correct and all components work properly. Water level may be checked at the clear plastic tube inside the front compartment.
6. Wash several loads. Insure that chemicals are metered in the appropriate quantities and that glasses are clean.
7. Re-check for leakage at plumbing or cabinet.
8. Confer with owner to insure that he understands the operation and is satisfied with the start-up.

3.2 WARRANTY

Record Model #, Serial #, and other necessary information on Warranty Card and forward to:

**AMERICAN DISH SERVICE
900 BLAKE STREET
EDWARDSVILLE, KS 66111-3820**

4.0 CHEMICALS

All ADS machines require detergent and sanitizer for proper operation. A rinse-aid may be used if desired.

Selection of the proper chemicals and the correct amounts will depend on several factors. Proper selection is vital if optimum results are to be realized. It may be necessary to change chemicals or adjust the quantity after the initial selection.

4.1 DETERGENT

Detergent is used to “emulsify” grease and loosen soil. Emulsification is a process which breaks down grease into very small particles which then mix with water. The detergent also reduces surface tension of the water to dissolve soluble matter.

The detergent selected must be designed for low-temperature dishwashing. Always use established brands.

The proper quantity of detergent may vary over a wide range, and depends on the following factors:

1. Water hardness.
2. Type and amount of grease.
3. Length of time the dishes stand.
4. Iron content of water.
5. Detergent formulation.

For this reason, your chemical distributor should be consulted to determine the amount which will give good results with lowest detergent usage. Your distributor should use the Hatch Test Kit to test water hardness before making a recommendation. After the machine has been in use or if conditions change, the setting can be readjusted for optimum results.

4.2 SANITIZER

Sanitizer should be 6% solution of sodium hypochlorite. Initial setting is 5cc and this should be checked periodically with a Chlorine Test Kit. Free chlorine in the final rinse should be 50ppm or more.

4.3 RINSE-AID

Rinse-aid reduces surface tension and causes the rinse water to run off in sheets rather than collect in droplets. This exposes more water surface to the air which allows the glasses to dry faster and prevents spot formation.

The optimum amount of rinse-aid varies depending on many of the same factors that affect detergent usage. Consult your chemical supplier and use nationally recognized brands.

5.0 PREVENTIVE MAINTENANCE

The machine should be inspected approximately once a month. The following steps will prevent many costly repairs.

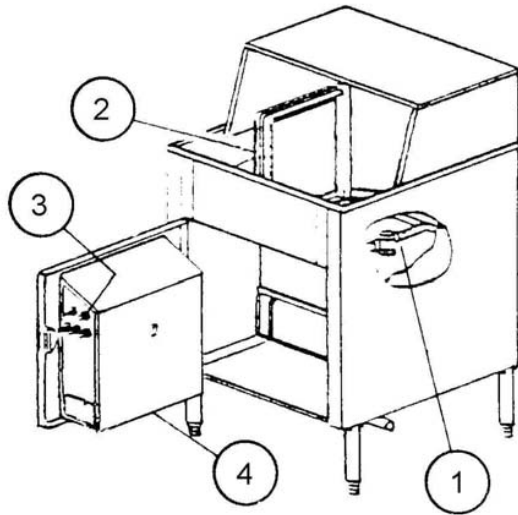

1. Check that Operator Procedures have been followed.
2. Inspect spay arm hub (1) for tightness and spray arm for free rotation (See Section 7.2.0).
3. Assemble machine and check for distortion of sheet metal parts, ease of assembly and proper operation of carousel and latch (2). Check for proper gap between carousel and splash guards (See Section 7.1.1).
4. Using manual fill switch (3), check fill rate and water level.
5. During the machine cycle, check the following:
 - a. Leakage at vacuum breaker or cabinet.
 - b. Timer for proper operation.
 - c. Operation and flow of chemical pumps.
 - d. Operation of pilot lights and switches.
6. Remove control box cover (4) and check the following:
 - a. Cycle counter and drive tube.
 - b. Chemical pumps and rotors (lubricate if required).
 - c. Squeeze tubes.
 - d. Chemical intake and discharge tubes.
 - e. Timer and switches.
 - f. Wiring for loose connections.
7. Inspect door hinges and latch.

TROUBLESHOOTING INDEX

<u>DESCRIPTION</u>	<u>PAGE</u>
6.0 TROUBLESHOOTING	2
Machine Will Not Operate – Green Light Off	3
Machine Will Not Operate – Green Light On	4
Cycle Will Not Resume After Wash	5
Machine Repeats Cycle	6
Pump Motor Will Not Operate	7
Pump Will Not Stop - Timer Is In Neutral	8
Motor Stops After Short Time	9
Recirculating Pump Leaks	10
Noisy Recirculating Pump	11
Low or Unsteady Pump Pressure	12
Detergent Pump Will Not Operate	13
Detergent Pump Will Not Stop	14
Sanitizer Pump Will Not Operate	15
Sanitizer Pump Will Not Stop	16
Rinse-Aid Pump Will Not Operate	17
Rinse-Aid Pump Will Not Stop	18
Chemical Does Not Flow	19
Heater Will Not Shut Off	20
Heater Will Not Operate	21
Fill Water Will Not Stop	22
Machine Does Not Fill	23
Water Leaks From Vacuum Breaker	24
Spray Arm Does Not Spin Properly	25
Glasses Not Clean – But Machine Operates	26
Excessive Foaming	27
 <u>DIAGRAMS</u>	
Electrical Component Identification	
Interconnection Diagram with Chemical Alert	91-0001
Ladder Diagram with Chemical Alert	91-0002
Interconnection Diagram without Chemical Alert	91-0003
Ladder Diagram without Chemical Alert	91-9004

6.0 TROUBLESHOOTING

Scope – This section should be used to isolate problems if the machine malfunctions. When a diagnosis has been made and confirmed, refer to Section 7.0 for repair procedures.

CAUTION

ALWAYS turn off Power Switch when removing or replacing electrical covers.

ALWAYS use extreme care when checking voltages.

ALWAYS turn off Power Switch and disconnect circuit breaker or fuses before making electrical repairs.

To use the troubleshooting charts, find the chart which describes the problem best in the upper left hand corner. A series of questions is asked and should be answered “YES” or “NO”. This answer leads to the next question until the problem is isolated and a repair is described. When the electrical control system is involved, a portion of the circuit diagram is included on the chart to assist in understanding.

Unless otherwise stated, voltage measurements should be taken from the neutral buss.

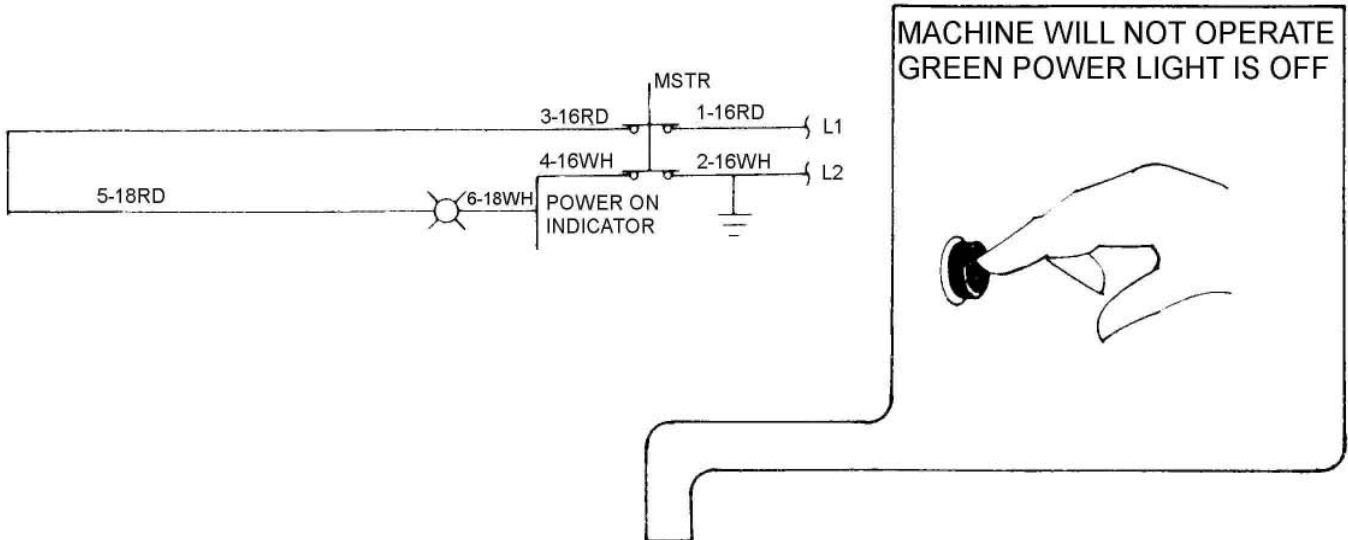

Is fuse blown or breaker tripped?



Reset or replace

Is there voltage between 1-16RD and 2-16RD at field wire box?

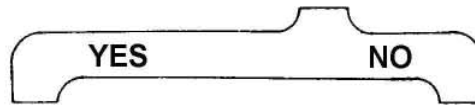

Is there voltage between 1-16RD and 2-16WH at master switch?

Repair building electrical system.

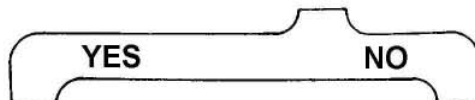

With switch on, is there voltage between 3-16RD and 4-16WH?

Repair loose connection.



Is power lamp burned out?

Replace contact block on master switch. (7.4)

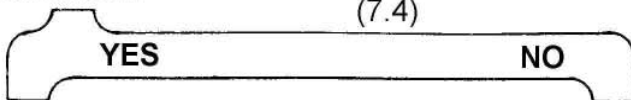

Replace lamp. (7.4)

Repair loose connection.

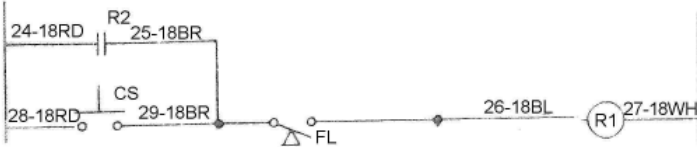

MACHINE WILL NOT OPERATE - GREEN POWER LIGHT IS ON



Does R1 relay close when red button is pressed?

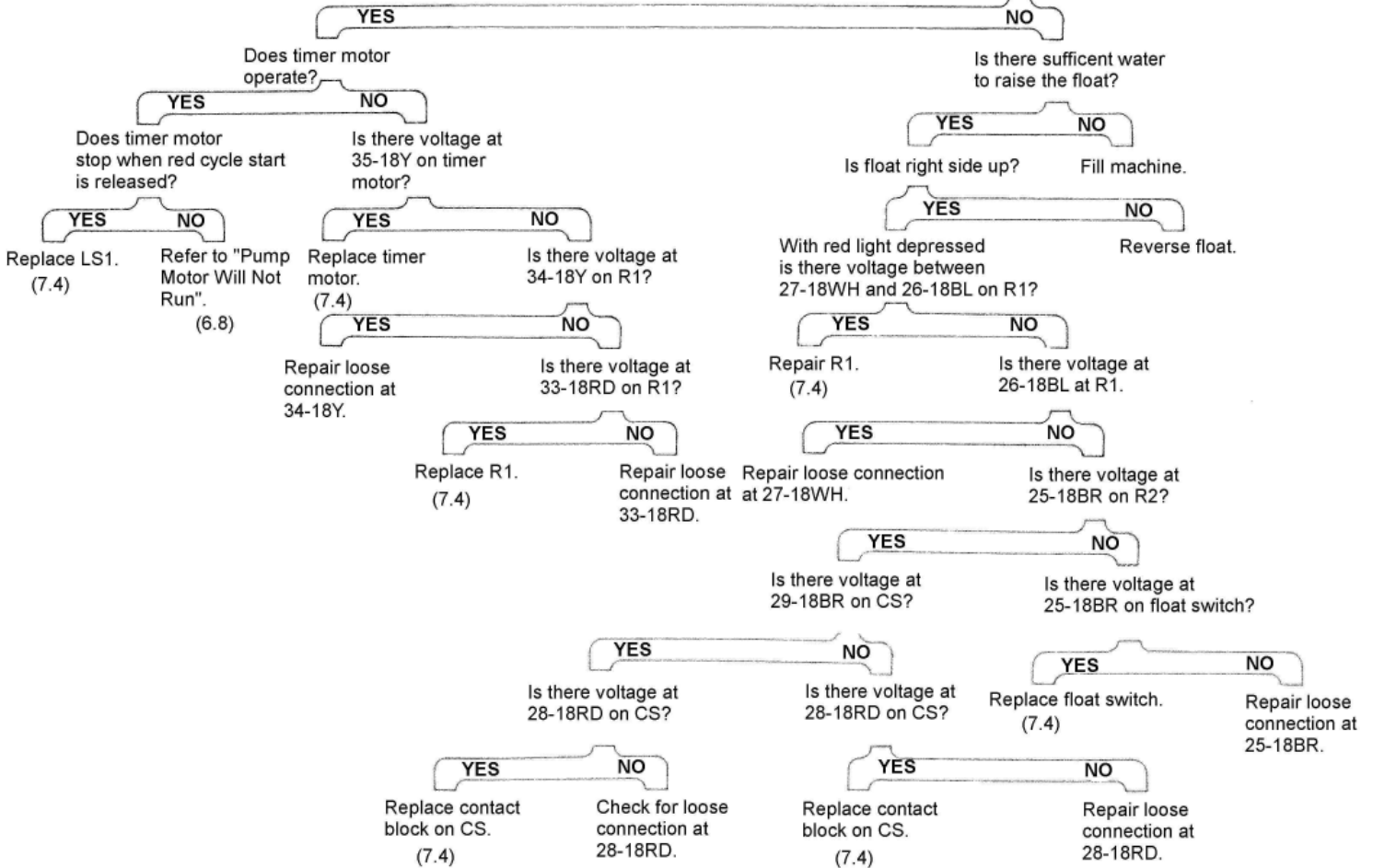

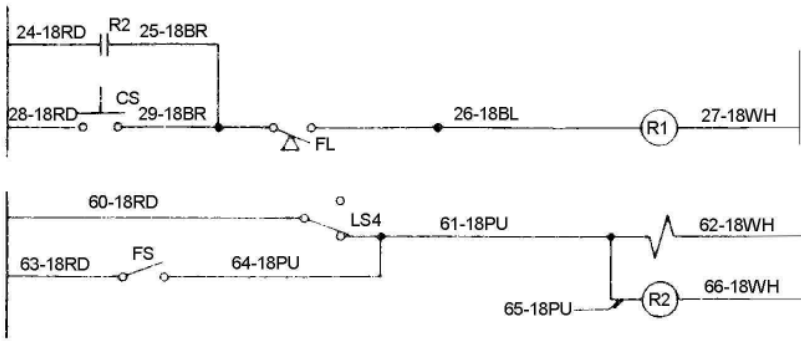

Is there sufficient water in sump to activate float switch?



Does R2 close when manual fill is depressed?

Refer to 7.4.3



Is there voltage at 28-18RD on R2?

Is there voltage between 65-18PU and 69-18WH at R2?



Replace R2.
(7.4)

Repair connection in 28-18RD.

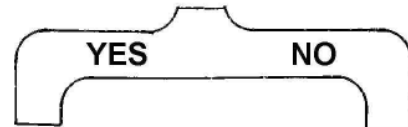

Replace R2.
(7.4)

Repair loose connection in 69-18WH or 65-18PU.

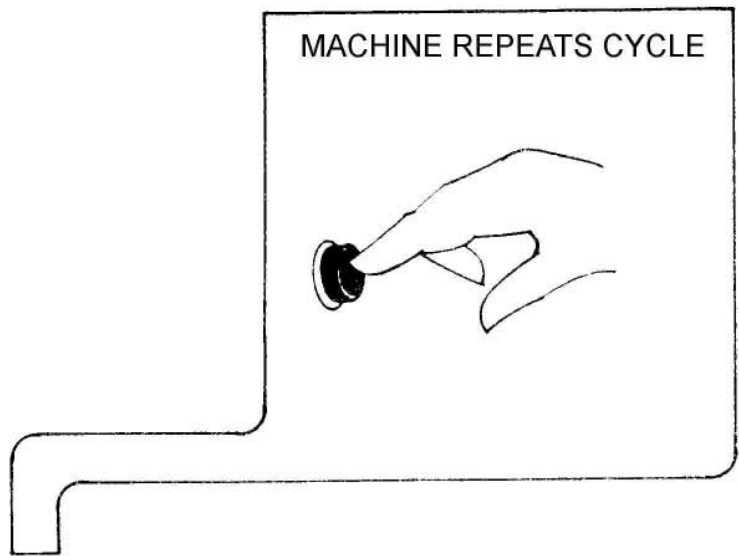

Does R1 energize when power switch is turned on?

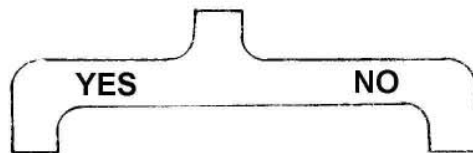

Replace LS1.
(7.4)

Replace contact block
on cycle (instant)
start switch (CS).
(7.4)

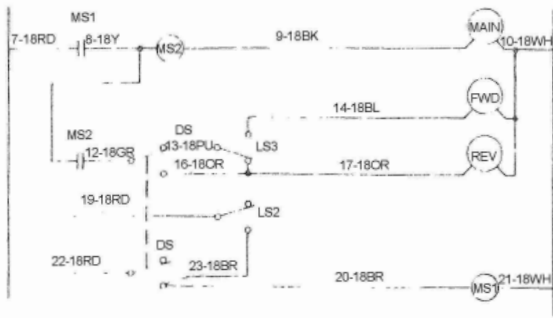

NOTICE
THE FOLLOWING TESTS SHOULD BE DONE WITH LS2 IN THE UP POSITION.

PUMP MOTOR WILL NOT OPERATE



Does pump operate when drain switch is actuated?

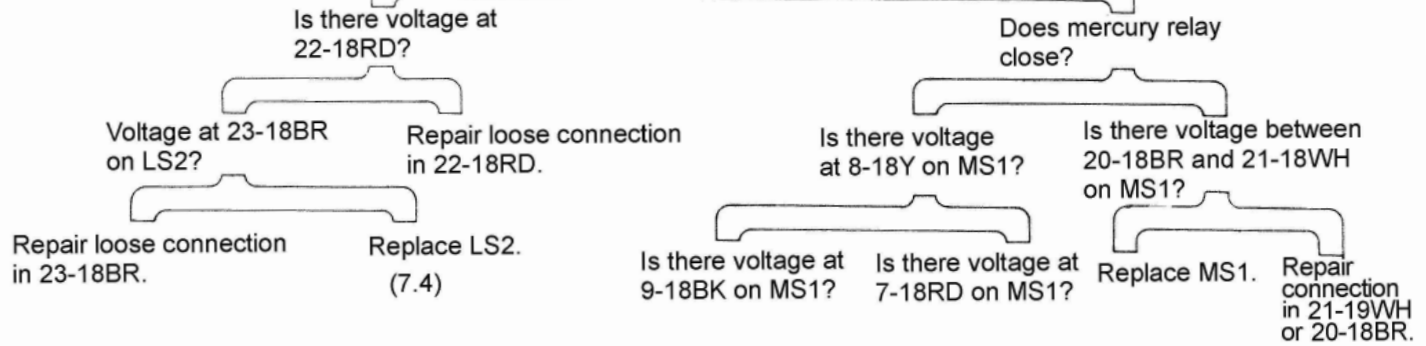

For the following tests place a jumper wire across lower terminals of MS2 and unplug motor at molex plug. Turn machine on and place LS2 in lower position.

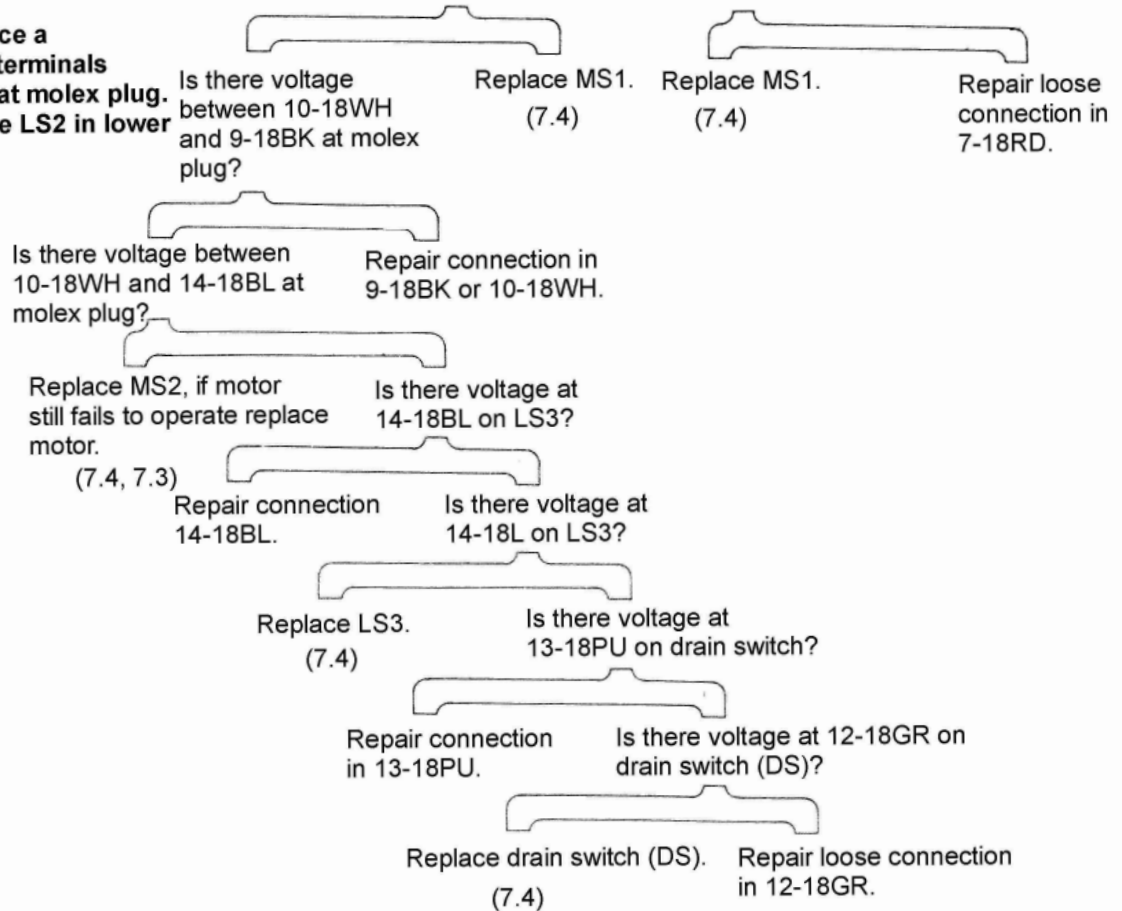

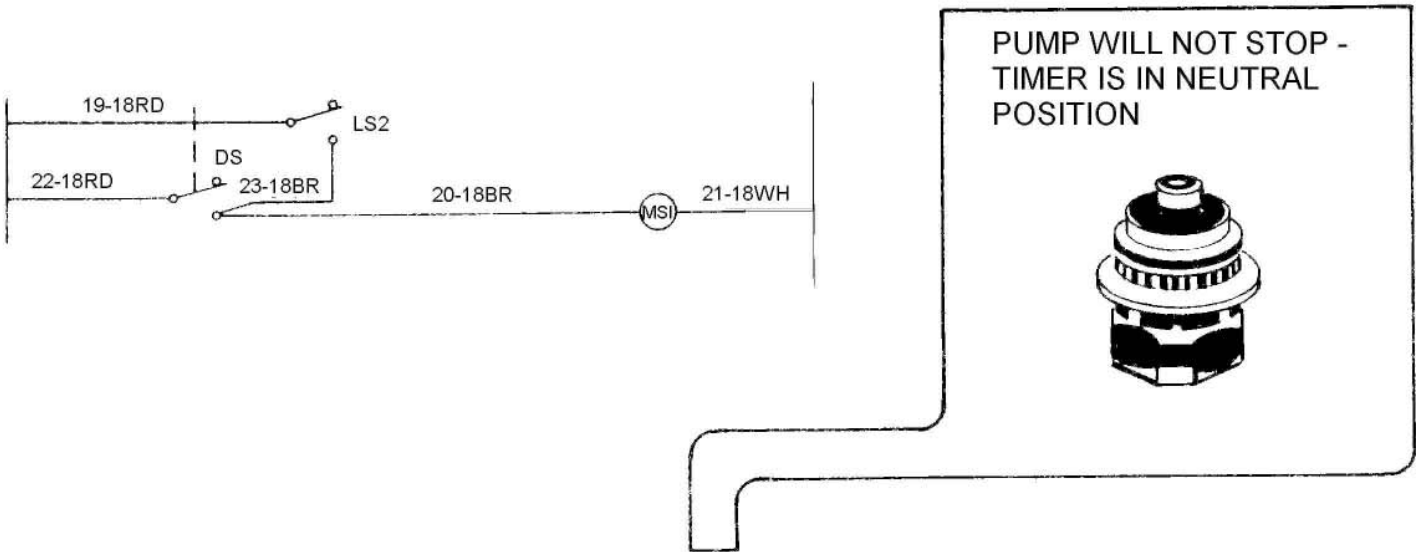

Is there voltage at 20-18BR on motor relay (MSI)?

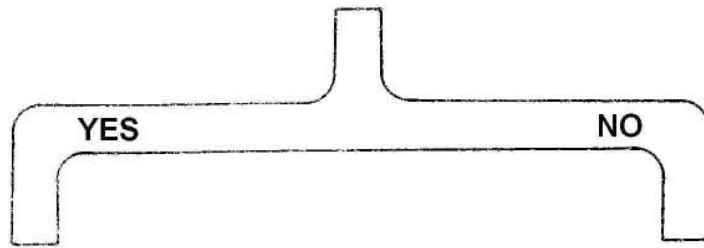

Does pump continue to operate with 19-18RD removed from LS2?

Replace MSI.
(7.4)



Replace drain switch (DS).
(7.4)

Replace LS2.
(7.4)

MOTOR STOPS AFTER
SHORT TIME



Does start winding relay (MS2)
operate properly when tested
with neon light?

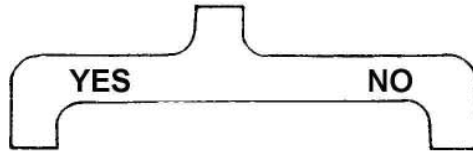

Replace motor.
(7.3)

Replace MS2.

RECIRCULATING PUMP LEAKS



Is leak at shaft?

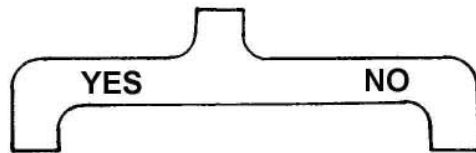

Replace pump.

(7.3)

Replace gasket between
pump and sump.

(7.3)

NOISY RECIRCULATING PUMP



With Upper Housing removed,
Spin Impeller. Are bearings
rough?

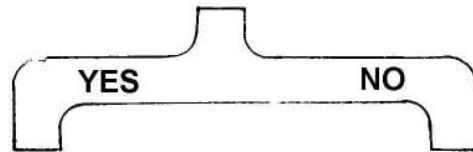

Replace motor.
(7.3)

Clean impeller.
(7.3)

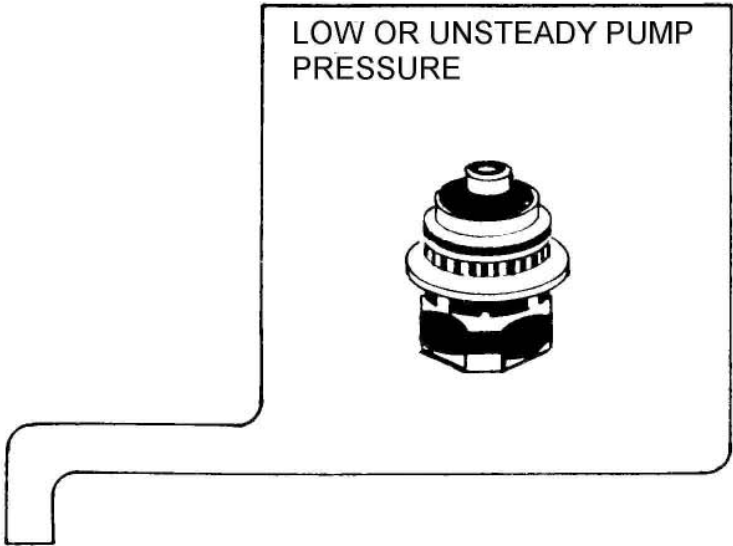

Does pressure fluctuate?

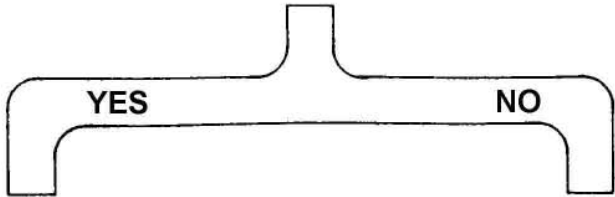

Adjust water level.
(7.4)

Are spray jets worn?

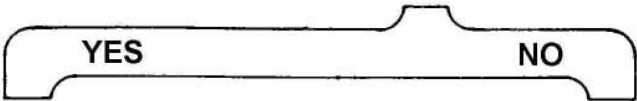

Replace spray arm.

Clean impeller.
(7.3)

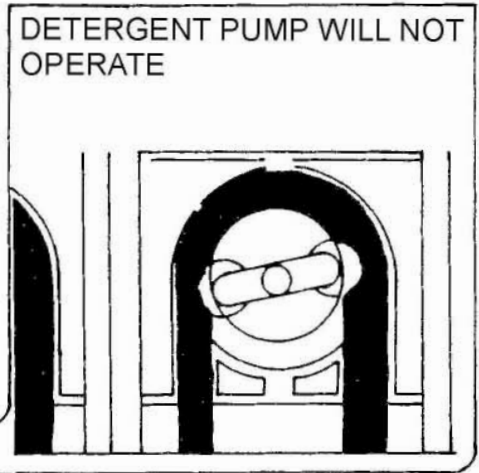
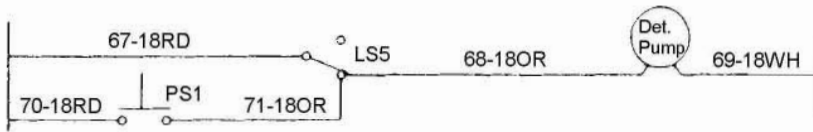

NOTICE
PERFORM THESE TESTS WITH
LS5 IN DOWN POSITION

Does pump operate with prime
switch (PS1) depressed?

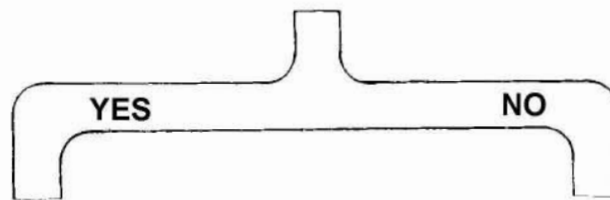

Is there voltage at 67-18RD
on LS5?

Is there voltage between 68-18OR
and 69-18WH at pump?

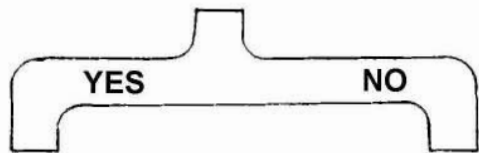

Replace LS5.
(7.4)

Repair loose connection
on 67-18RD.

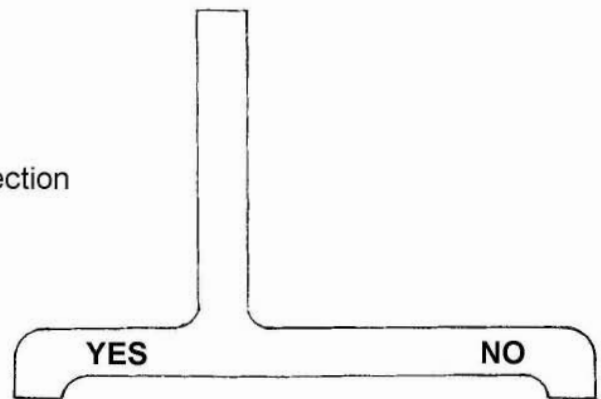

Replace pump.
(7.4)

Repair connection
in 69-18WH.

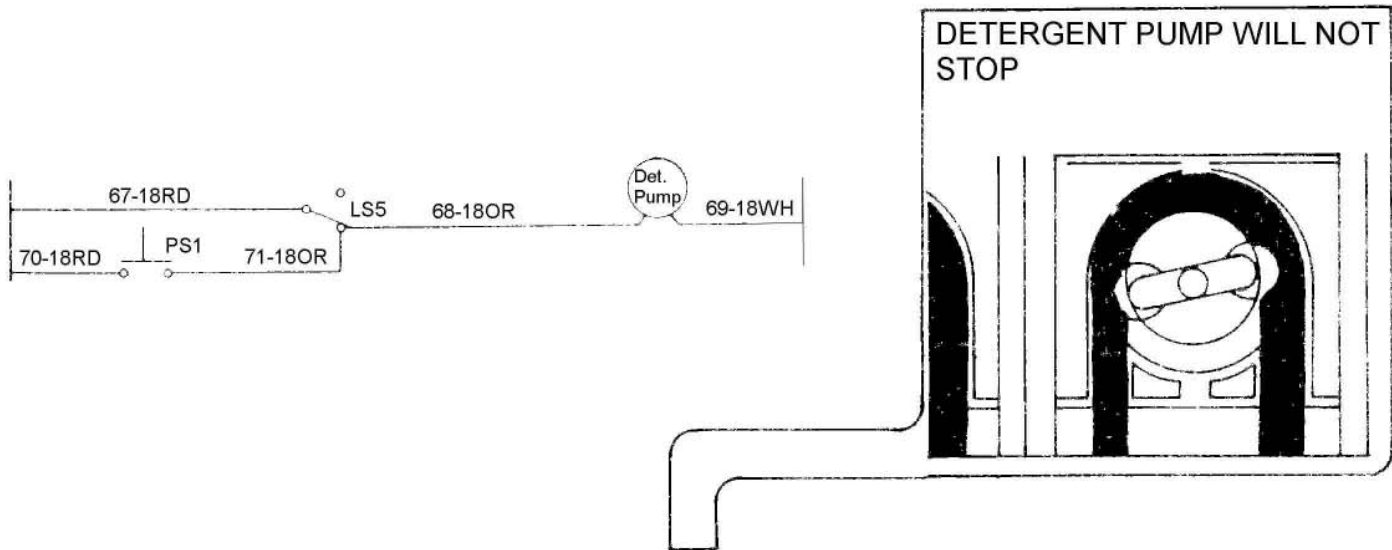

With timer in neutral position & wires 68-18OR and 71-18OR removed from LS5, does pump continue to operate?

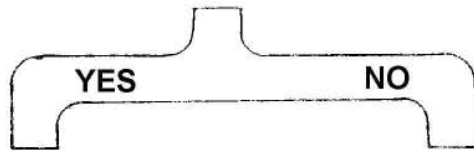

Replace PS1.
(7.4)

Replace LS5.
(7.4)

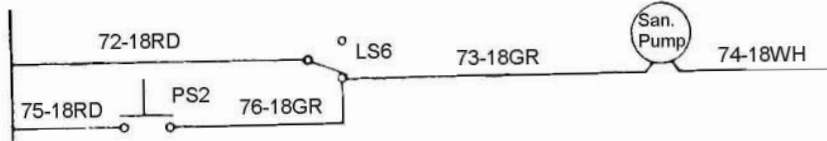

SANITIZER PUMP WILL NOT OPERATE

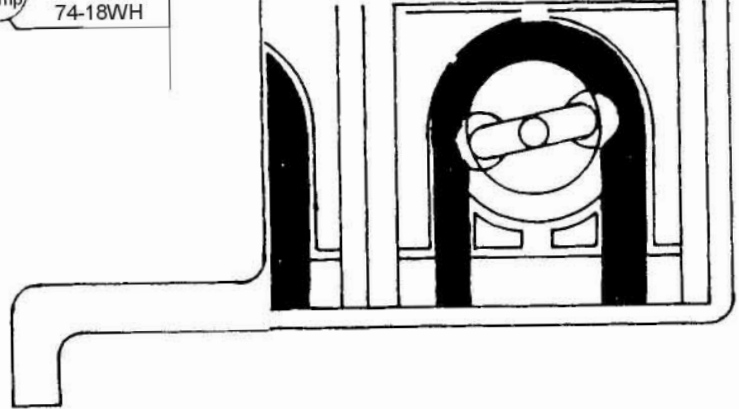

NOTICE
PERFORM THESE TESTS WITH
LS6 IN DOWN POSITION

Does pump operate with prime
switch (PS2) depressed?

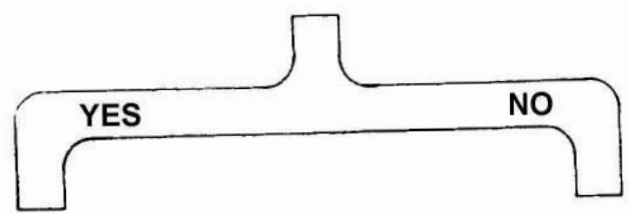

Is there voltage at 72-18RD
on LS6?

Is there voltage between 73-18GR
and 74-18WH at pump?

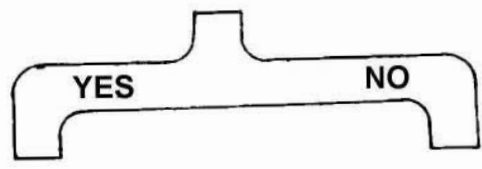

Replace LS6.
(7.4)

Repair connection in
72-18RD.

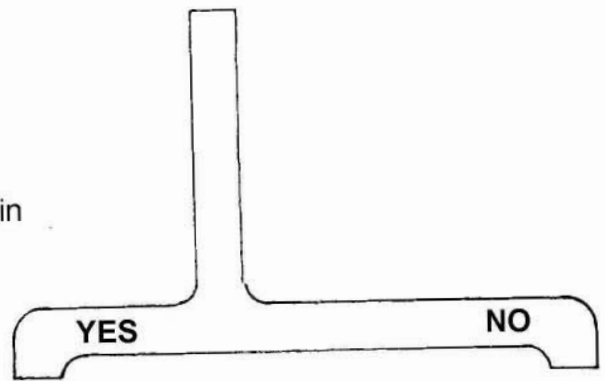

Replace pump.
(7.4)

Repair loose connection
in 74-18WH or 73-18GR.

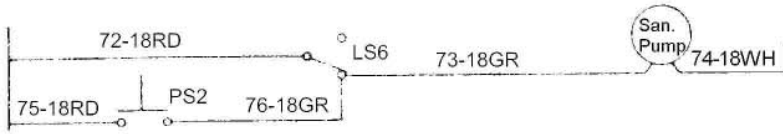

With timer in neutral & wires
73-18GR and 76-18GR removed
from LS6, does pump continue to
run?

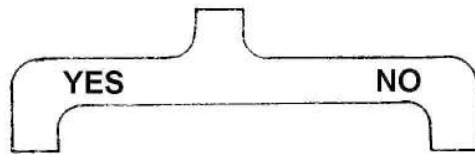

Replace PS2.
(7.4)

Replace LS6.
(7.4)

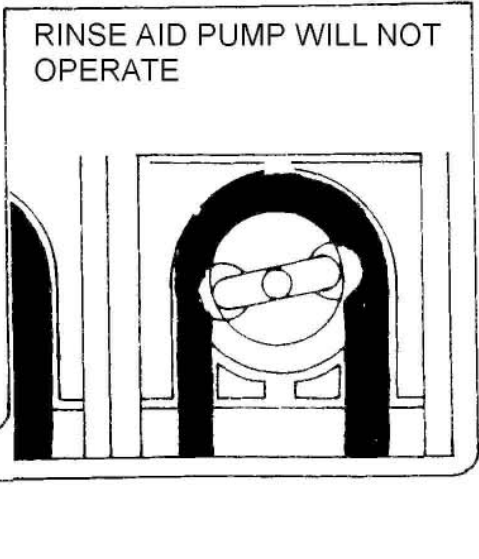
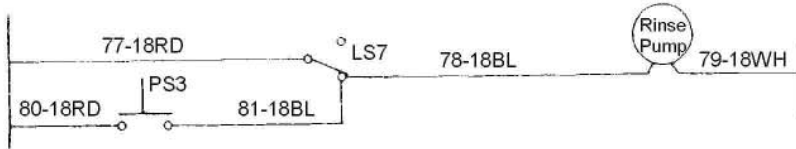

NOTICE
PERFORM THESE TESTS WITH
LS7 IN DOWN POSITION

Does pump operate with prime
switch (PS3) depressed?

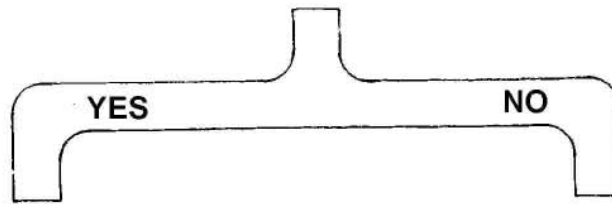

Is there voltage at 77-18RD on LS7?

Is there voltage between 78-18BL
and 79-18WH on pump?

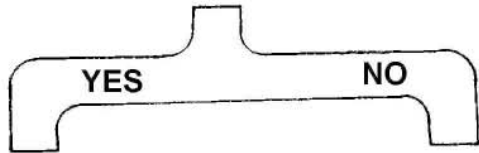

Replace LS7.
(7.4)

Repair Connection
in 72-18RD.

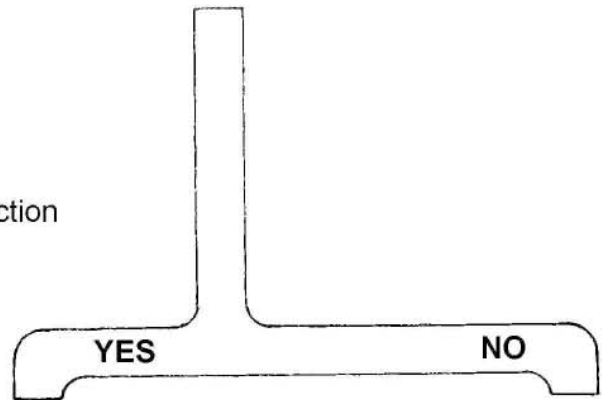

Replace pump.
(7.4)

Repair loose connection
in 78-18BL or 79-18WH.

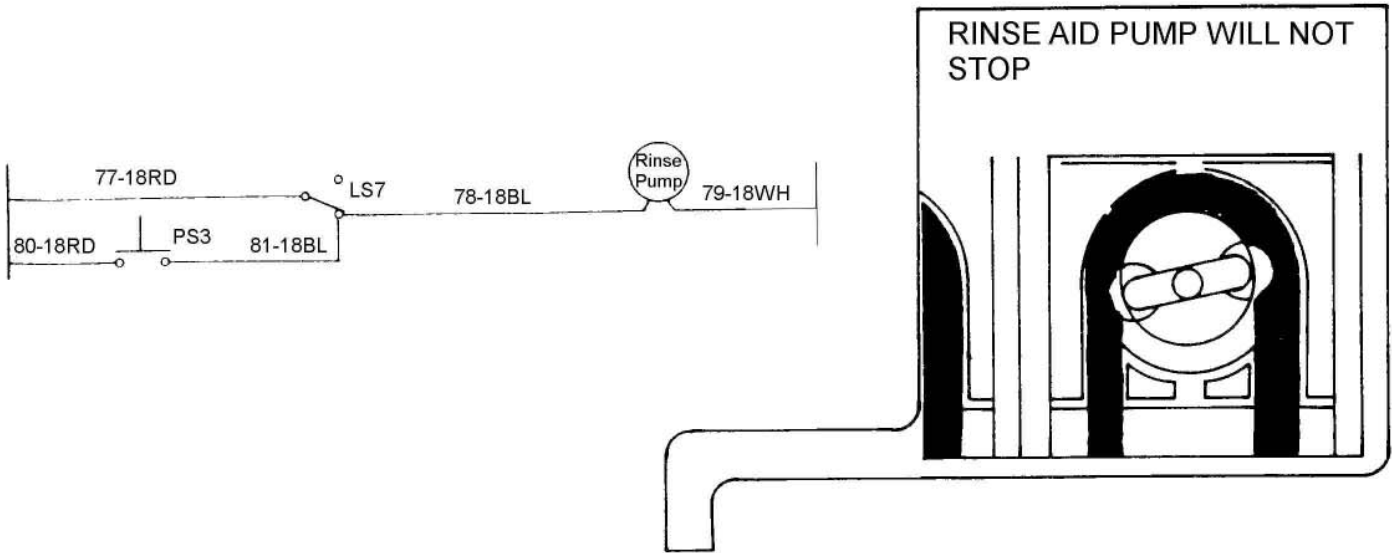

With timer in neutral & wires 81-18BL & 79-18BL removed from LS7, does pump continue to operate?

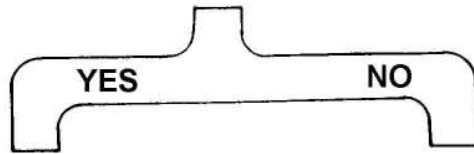

Replace PS3.
(7.4)

Replace LS7.
(7.4)

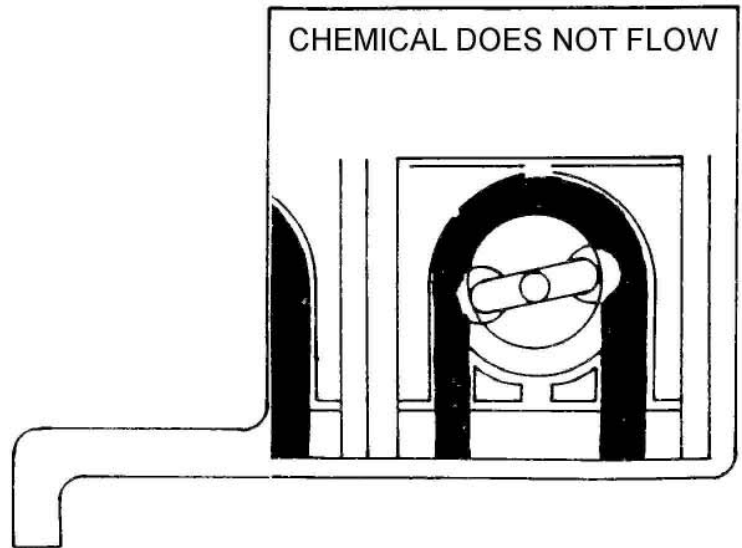

Is container empty?



Replace container.

Is intake tube submerged?



Is squeeze tube worn, cracked or brittle?

Position properly.



Replace squeeze tube.

Does pump operate?

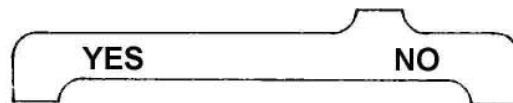

Inspect for air leakage in intake tube.

Refer to 6.14, 6.16, 6.18.

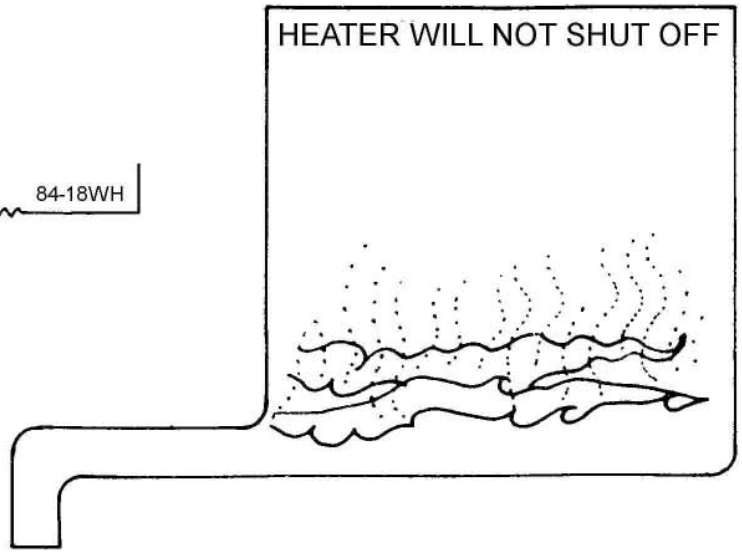

Replace thermostat (TS).

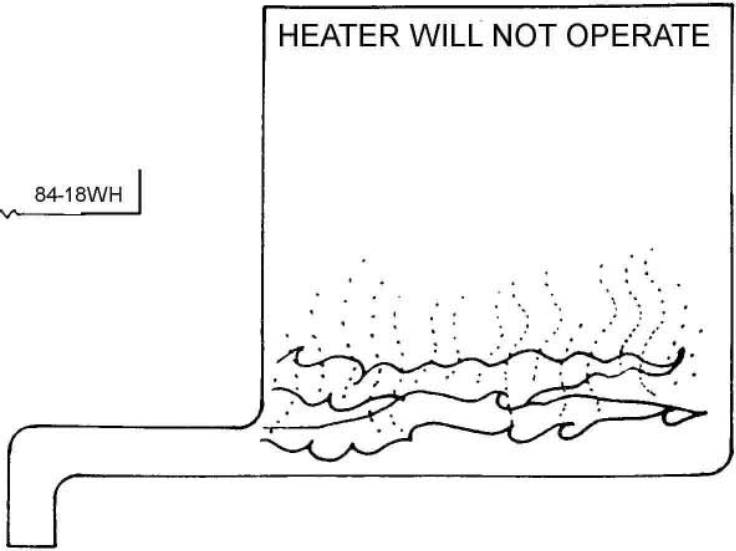
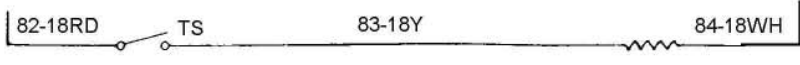

Is there voltage at 84-18WH on heater?

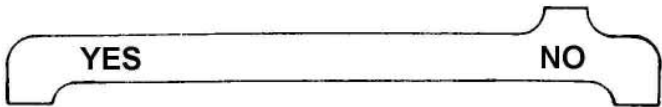

Repair loose connection in 84-18WH.

Is there voltage at 83-18Y on heater?

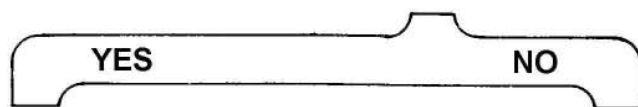

Replace heater.

Is there voltage at 82-18RD on TS?



Replace thermostat (TS).

Repair loose connection in 82-18RD.

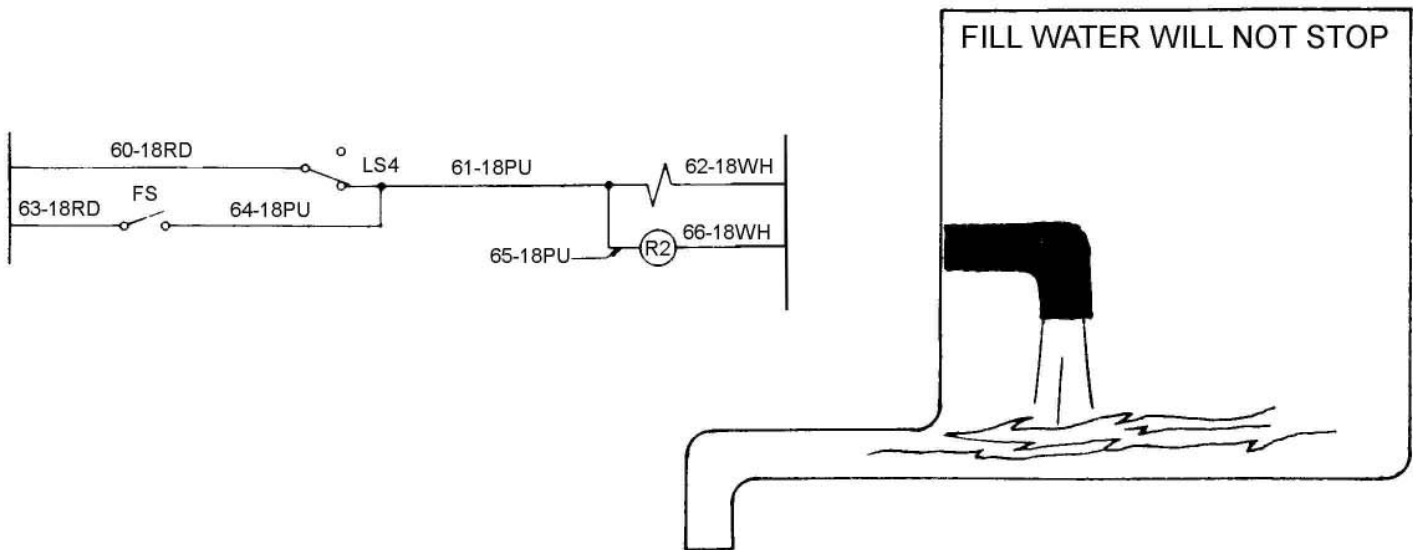

Does flow stop when master switch is turned off?

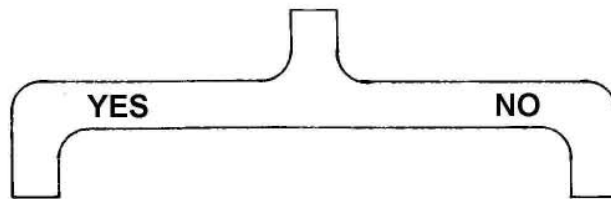

With 63-18RD disconnected from fill switch and master switch on, does flow stop?

Service solenoid valve diaphragm.
(7.5)

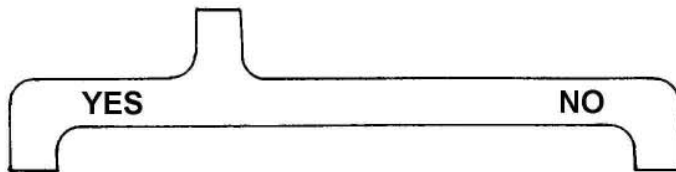

Replace fill switch (FS).
(7.4)

Replace #4 timer switch (LS4).
(7.4)

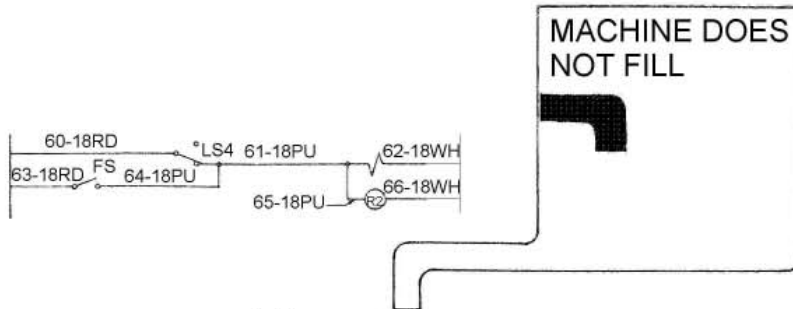

Is there water pressure at supply line?

YES **NO**

Are all the valves on?

Determine cause and remedy.

YES **NO**

Is inlet strainer clean?

Turn on valve.

YES **NO**

Does manual fill (FS) operate properly?

Clean inlet strainer.

YES **NO**

Is there voltage at 60-18RD on LS4?

Does solenoid valve click when fill button is depressed?

YES **NO**

YES **NO**

Replace LS7. (7.4)

Repair loose connection in 63-18RD.

Install diaphragm kit. (7.5)

With fill button depressed, is there voltage at 63-18RD on fill switch?

YES **NO**

Is there voltage at 64-18PU on LS4?

Repair loose connection in 63-18RD.

YES **NO**

Is there voltage between 61-18PU & 62-18WH on water solenoid?

Repair connection at 64-18PU.

YES **NO**

Replace solenoid coil. (7.5)

Repair loose connection at 61-18PU or 62-18WH.

WATER LEAKS FROM
VACUUM BREAKER

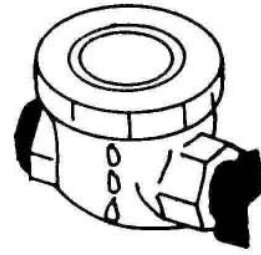

Overhaul vacuum breaker.

(7.5)

SPRAY ARM DOES NOT SPIN PROPERLY

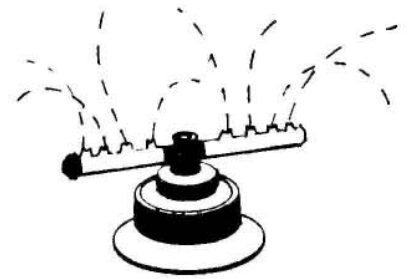

Is spray arm clean?

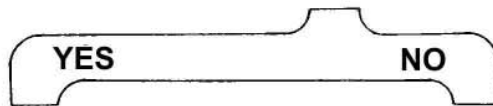

Is bearing free?

Clean spray arm.



Is water level correct?

Replace bearing and/or spray arm.

(7.2)

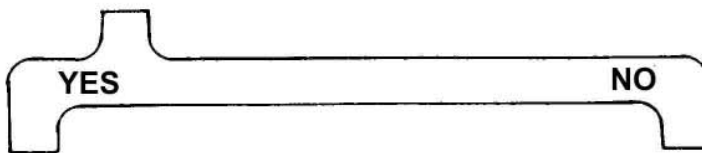

Check spray arm pressure.

(7.2)

Adjust water level

(7.5)

GLASSES NOT CLEAN BUT
MACHINE OPERATES

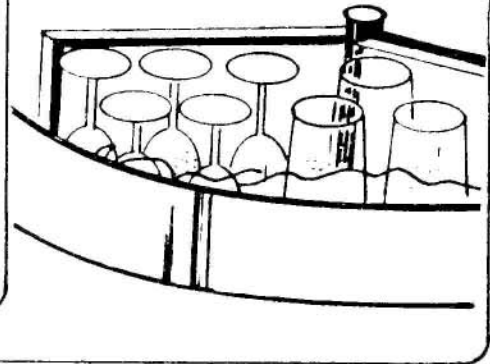

Is detergent supply depleted?

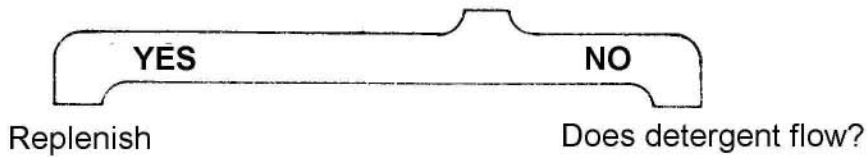

Does spray arm rotate
at 40 - 60 RPM?

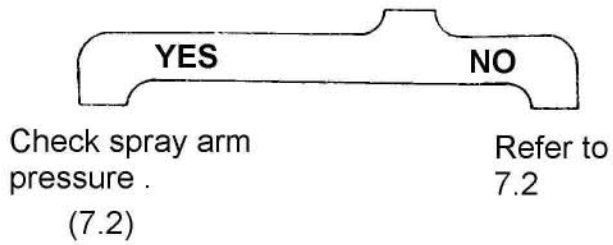

Does detergent pump
operate?

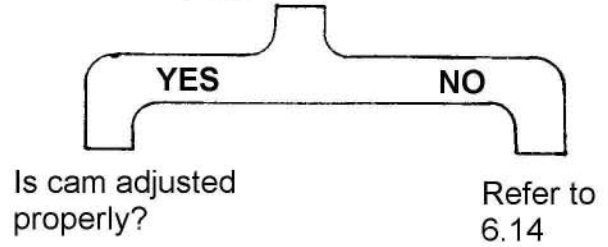

Is squeeze tube
worn?

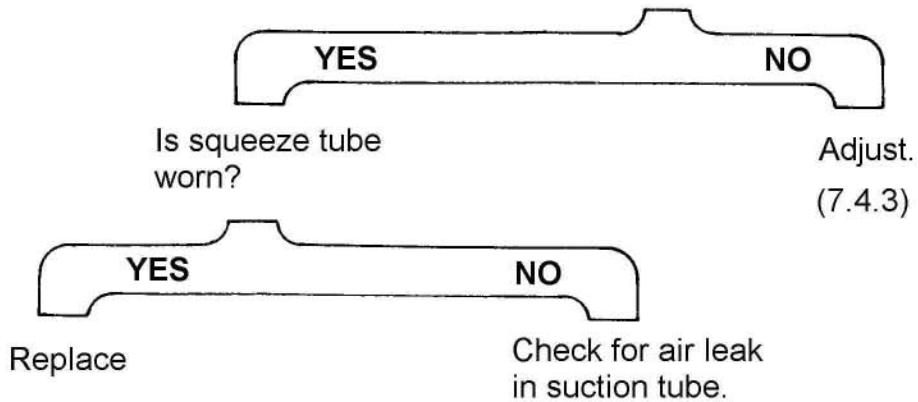

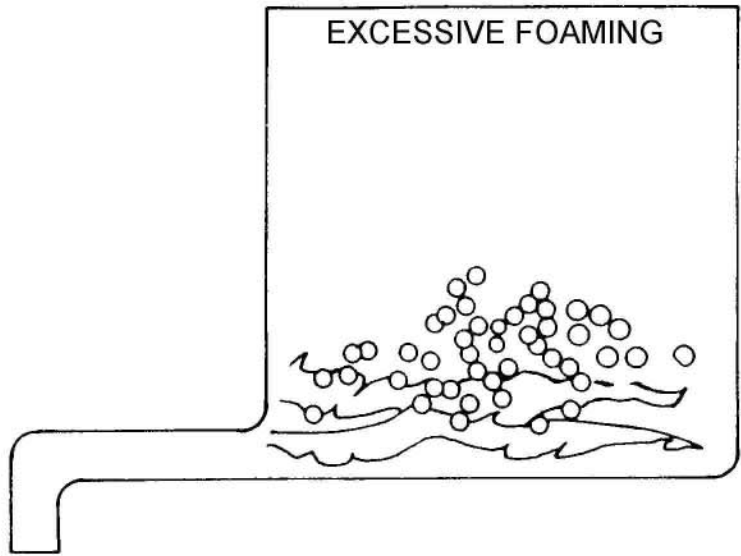

Are chemical intake tubes in proper containers?

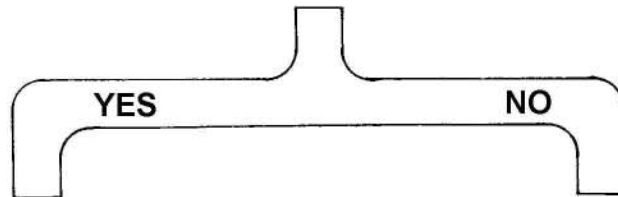

Is proper detergent being used?

Repair and flush lines.



Is correct amount of detergent being monitored?

Use proper detergent.

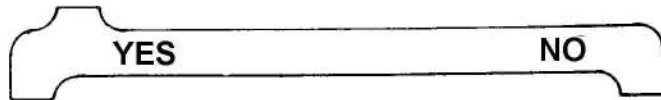

Is proper rinse aid being used?

Adjust.
(7.4.3)

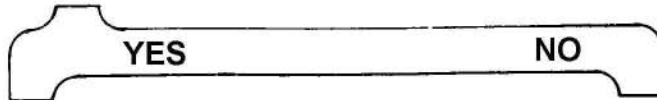

Is rinse aid metered in proper amount?

Use proper rinse aid.

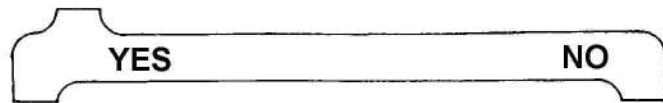

Look for low water temperature.

Adjust.
(7.4.3)

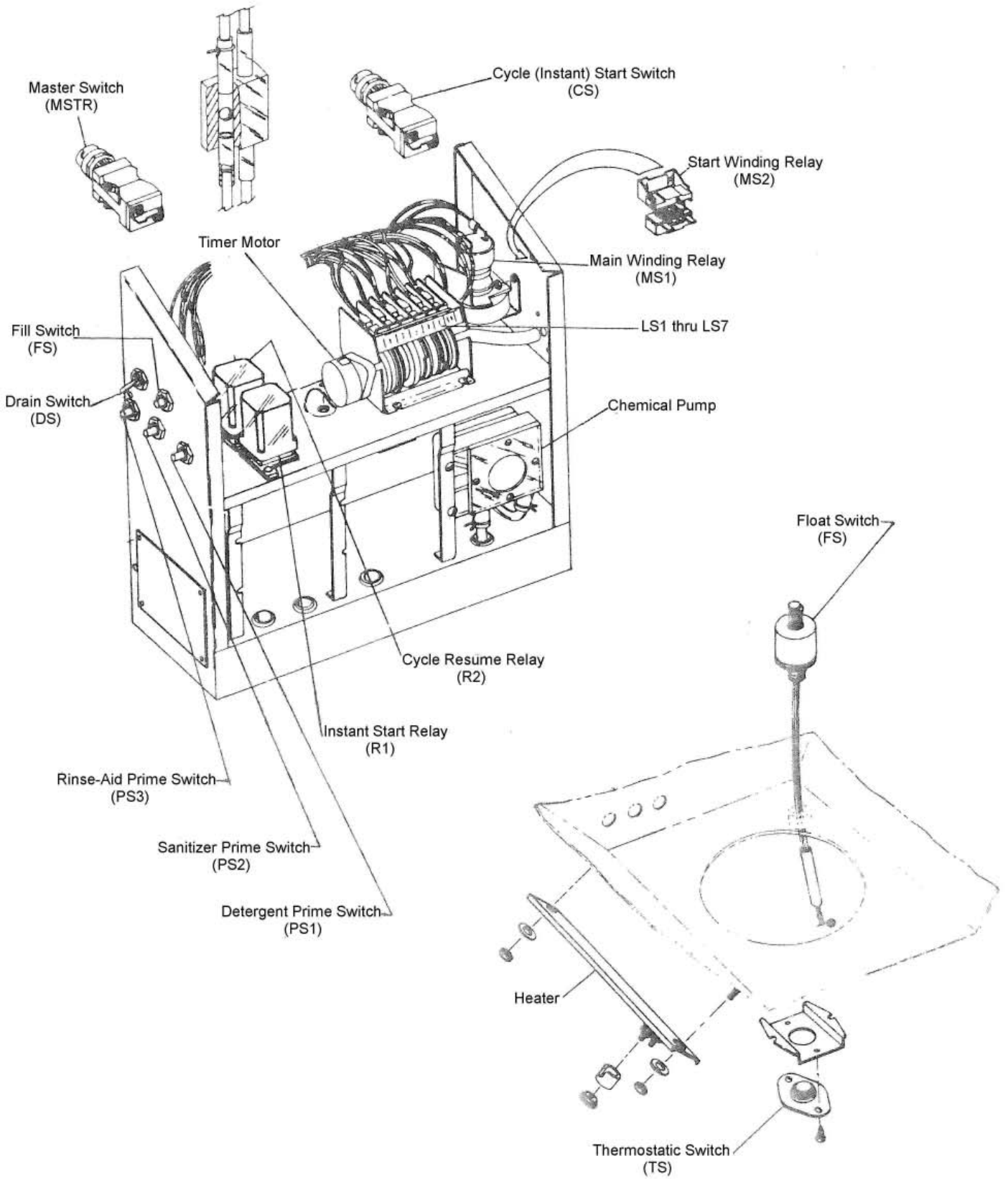

REPAIR PROCEDURES INDEX

	<u>DESCRIPTION</u>	<u>PAGE</u>
7.0	REPAIR PROCEDURES	2
7.1	CABINET ASSEMBLY	3
	7.1.1 Carousel Adjustment	3
	7.1.2 Height Adjustment	5
7.2	SPRAY SYSTEM	6
	7.2.1 Pressure Check	6
	7.2.2 Bearing and/or Spray Arm Replacement	7
7.3	PUMP/MOTOR ASSEMBLY	8
	7.3.1 Upper Pump Housing Replacement	8
	7.3.2 Pump/Motor Replacement	10
7.4	CONTROL SYSTEM	11
	7.4.1 Timer Motor Replacement	13
	7.4.2 Cam Adjustment	13
	7.4.3 Timer Switch Replacement	15
	7.4.4 Motor Relay Replacement	15
	7.4.5 Replacement of Start Winding Relay	15
	7.4.6 Chemical Pump Replacement	16
	7.4.7 Heater Replacement	16
	7.4.8 Thermostat Replacement	16
	7.4.9 Float Switch Replacement	16
	7.4.10 Power or Cycle Start Switch Repair	17
	7.4.11 Cleaning Flow Indicator	19
	7.4.12 Flow Indicator Replacement	19
7.5	FRESH WATER PLUMBING	20
	7.5.1 Clean/Replace Strainer Screen	20
	7.5.2 Replace Shut-Off Valve Packing	20
	7.5.3 Service Solenoid Valve Diaphragm	23
	7.5.4 Replace Solenoid Valve Coil	23
	7.5.5 Overhaul Vacuum Breaker	23
	7.5.6 Plumbing Removal	25

7.0 REPAIR PROCEDURES

Repair procedures are organized around the major sub-assemblies of the machine. Most common procedures are included. In addition to specific procedures, each major sub-assembly is discussed with respect to its construction and operation. Before attempting any repair, maintenance personnel should be thoroughly familiar with the construction and operation of the equipment and should be certain that the diagnosis is correct.

7.1.0 CABINET ASSEMBLY (See Figure 7.1)

The cabinet of the Model ASQ Glasswasher is of welded stainless steel construction. The lower section of the cabinet has two compartments. The motor compartment houses the pump motor, solenoid valve and several electrical components. Except during maintenance the motor compartment panel (1) must always be in place.

The front compartment provides storage areas for washing, sanitizing and rinse-aid chemicals. The control box (2) which is mounted on the door is also contained in this compartment.

The carousel (3) which holds the glasses is supported at the bottom on a pivot pin and at the top by a ring on the hood top. Alignment of the carousel is attained by moving the lower pivot left or right. On some machines, shims may be used to position the pivot front to rear. A latching mechanism maintains position of the carousel.

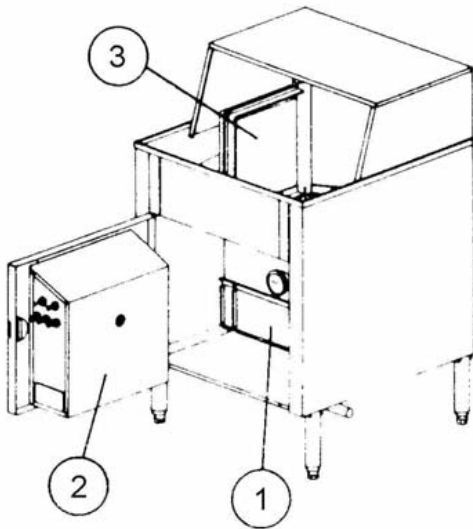
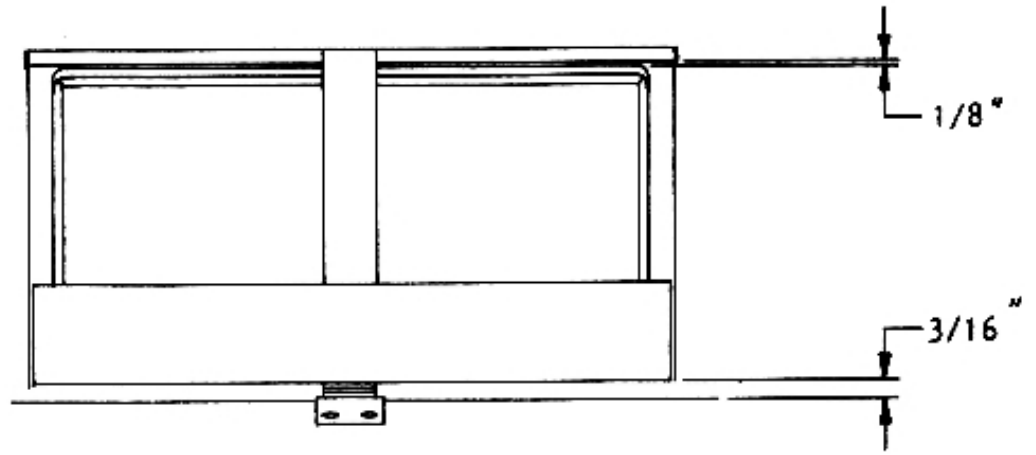

Figure 7.1

7.1.1 CAROUSEL ADJUSTMENT (See Figure 7.1.1)

Alignment of the carousel is critical to proper operation and sealing of the wash compartment. This alignment is made at the factory but if the machine is damaged or a new hood is installed this alignment could be altered. Before making any alignment changes be absolutely sure that the hood and hood top are seated firmly in place and there are no broken or protruding parts.

1. Assemble the machine and check the gap above the carousel divider and below. This gap should be approximately 1/8 inch at the top and 3/16 inch at the bottom and should be even along the entire length and the same on both sides.



Correct Alignment

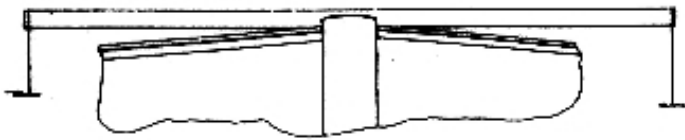

Adjust Lower Pivot To Rear

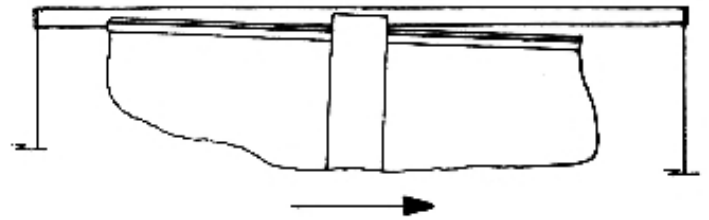

Adjust Lower Pivot To Right

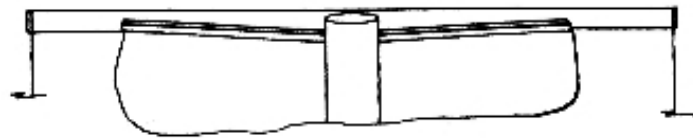

Adjust Lower Pivot Forward

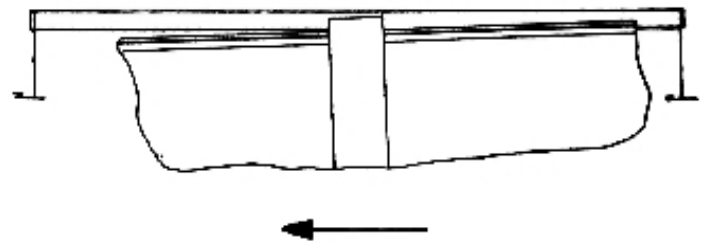

Adjust Lower Pivot To Left

Figure 7.1.1

2. Adjust the lower pivot in order to attain an even gap along both sides at the top of the carousel.
3. The width of the gap may now be adjusted by installing or removing spacers at the bottom of the carousel.

7.1.2 HEIGHT ADJUSTMENT (See Figure 7.1.2)

1. Place level (1) on top of machine in both front-back and side-side directions to determine if machine is out of level and in which direction.
2. Adjust level by turning lower portion of bullet feet (2) with an open-end crescent wrench.

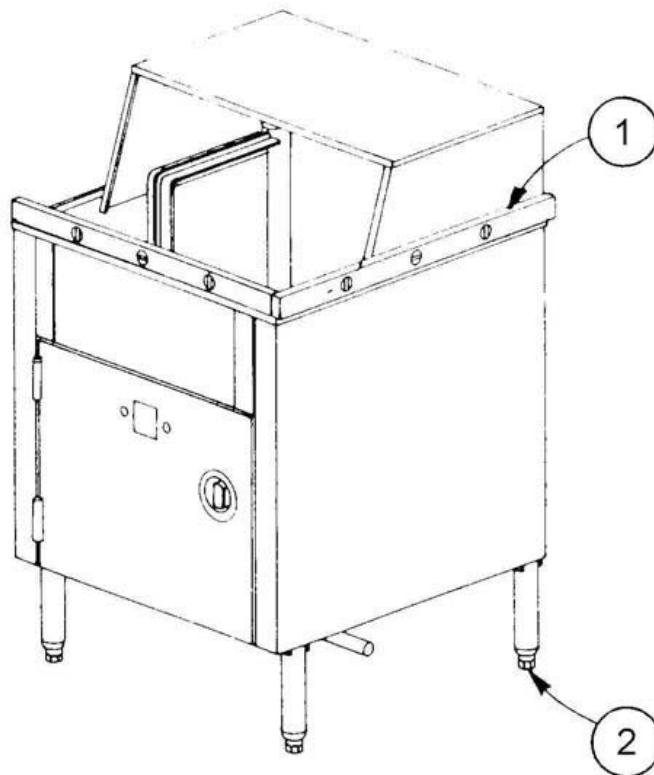

Figure 7.1.2

7.2.0 SPRAY SYSTEM

The Model ASQ Glasswasher spray system consists of a rotating spray arm with “V” type spray jets. The arm rotates on a stainless steel pivot and uses the hydro-static principle in which fluid is forced under pressure between the bearing surfaces. The bearing therefore rides on a thin film of water. The spray arm may be readily removed for daily cleaning.

7.2.1 PRESSURE CHECK (See Figure 7.2.1)

1. Install special pressure fitting (1) on one end of lower spray arm (2) and attach pressure gauge which reads 0.20 PSI.
2. Close doors and start machine.
3. Record pressure during wash portion of cycle. If pressure fluctuates, record maximum and minimum pressure.
4. Normal pressure may range from 8 PSI (5600 KG/M²) to 12 PSI (8400 KG/M²). If pressure is less than 8 PSI (5600 KG/M²) or fluctuates more than 3 PSI (2100 KG/M²), refer to Section 6.11.

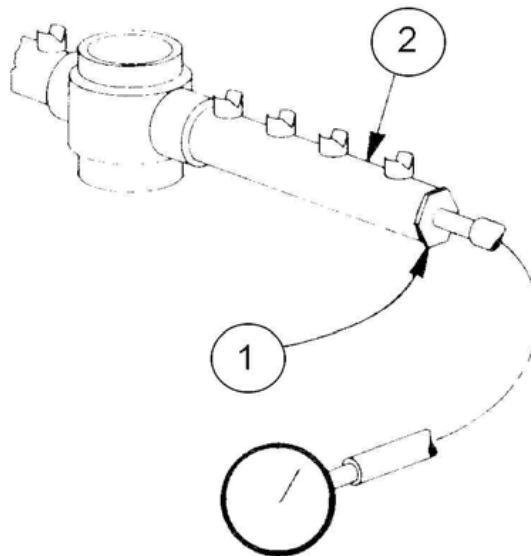
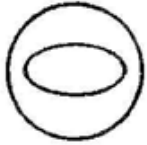

Figure 7.2.1

7.2.2 BEARING and/or SPRAY ARM REPLACEMENT

1. Remove spray arm.
2. Inspect bearing for scoring or excessive wear and replace if necessary.
3. Inspect spray arm hub for wear or scoring and jets for wear.



Normal

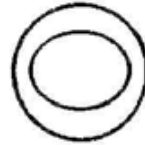

Worn

4. Replace spray arm as required.

7.3.0 PUMP/MOTOR ASSEMBLY

The Model ASQ Glasswasher uses an integral pump and motor assembly. Field repair of this unit is not recommended with the exception that the upper housing may be replaced if damaged or the gasket may be replaced if leakage occurs. Any other defects normally cause extreme damage to the pump or motor windings and replacement of the entire unit is the most economical and reliable repair.

This unit contains a recirculating pump for spraying water over the glasses as well as drain pump which pumps soiled water from the machine. The recirculating pump is activated when the motor is driven in the forward direction and drain pump is active when the motor reverses. The motor has three windings. The main winding energizes and provides power for the pump. The forward or reverse windings are energized for approximately ½ second when the motor is first started to initiate rotation in the proper direction. Once the motor is at operating speed the starting winding is de-energized by the motor start relay and the main winding continues to rotate the motor in either the forward or reverse.

Motor burn outs may be caused by failure of the motor start relay or a loose connection in the motor starting circuit. If a motor has been replaced because of burn out it is imperative that the main and starting circuits be checked and the motor start relay replaced.

7.3.1 UPPER PUMP HOUSING REPLACEMENT (See Figure 7.3.1)

1. Remove hood top, hood, carousel and splash shields.
2. Remove spray arm and scrap tray.
3. Remove eight screws (1) around the top of the pump housing (2) and remove housing.
4. Do not move or rotate any portions of the lower pump assembly.
5. Reassemble in reverse order.

RECIRCULATING
PUMP ASSEMBLY

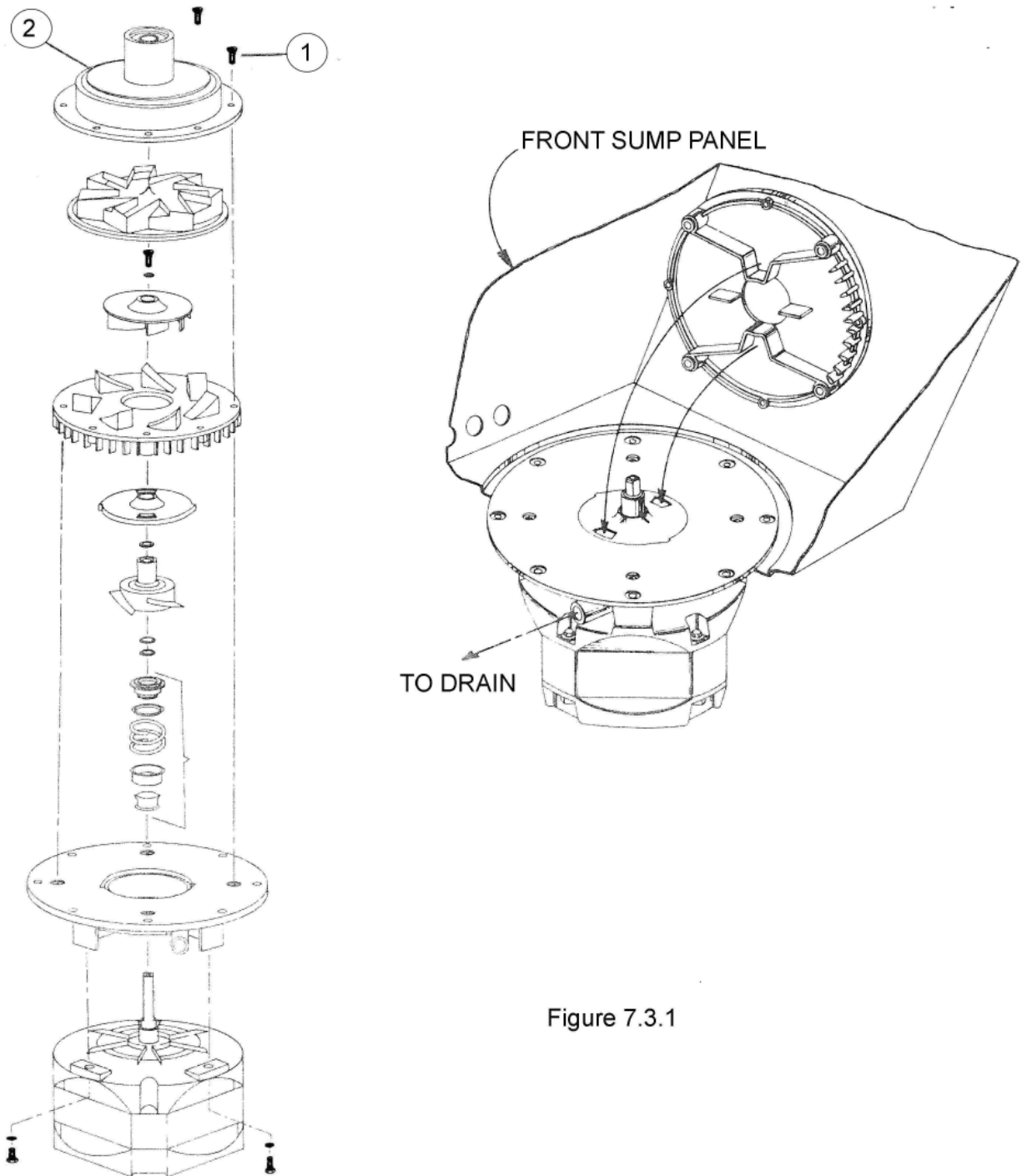
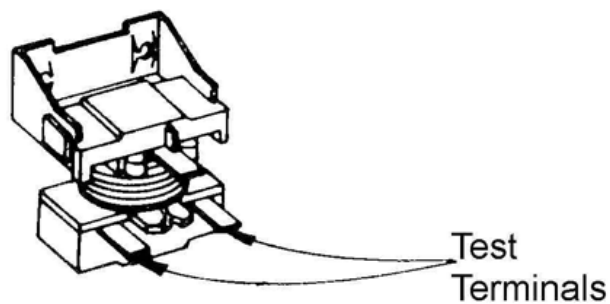

Figure 7.3.1

7.3.2 PUMP/MOTOR REPLACEMENT

1. Remove hood top, hood sides, splash shields, spray arm and scrap tray.
2. Remove motor compartment panel and floor.
3. Disconnect motor from wiring harness.
4. Remove eight screws attaching motor to sump bottom.
5. Remove motor/pump assembly.
6. Remove spray arm pivot from motor assembly.
7. Reassemble in reverse order making certain that the motor is oriented properly.
8. Before energizing machine connect a neon test light across the two lower terminals of the motor starting relay.
9. Press the "Power On" button and "Cycle Start" button, the neon test light should go out as soon as the main motor relay is energized. It will remain out for approximately $\frac{1}{2}$ second and then light again. If this does not occur IMMEDIATELY shut off power to the machine. Check the motor starting circuits and replace the motor start relay.



7.4.0 CONTROL SYSTEM

(See Figure 7.4)

The timer (1) consists of a drive motor and seven cams. These cams open and close seven switches which control most functions of the machine.

Switch #1 (LS1) controls the timer motor. When the machine is off and the timer is in its neutral position, no power is supplied to the timer motor. When the machine cycle starts, Switch #1 is activated and the timer motor drives the cams through their cycle.

Switch #2 (LS2) supplies power to the MOTOR RELAY which powers the main motor windings.

Switch #3 (LS3) activates either the forward or reverse motor start windings through the MOTOR START RELAY.

Switch #4 (LS4) controls the Solenoid Valve which supplies fresh water to the machine. Its cam is adjustable in order to control the starting point of the purge cycle and the water level.

Switches #5 (LS5), #6 (LS6), and #7 (LS7) control the detergent (RED), sanitizer (GREEN) and rinse-aid (BLUE) metering pumps respectively. The cams which operate these switches are also adjustable.

R1, the Instant Start Relay (2) supplies power to the timer and pump motors for approximately one second after the cycle start button is depressed. This allows time for Cam #1 to actuate.

R2, the Cycle Resume Relay (3) restarts the timer motor when the water level is near its proper point. Water continues to flow for several seconds and this time is adjustable to provide the exact water level required.

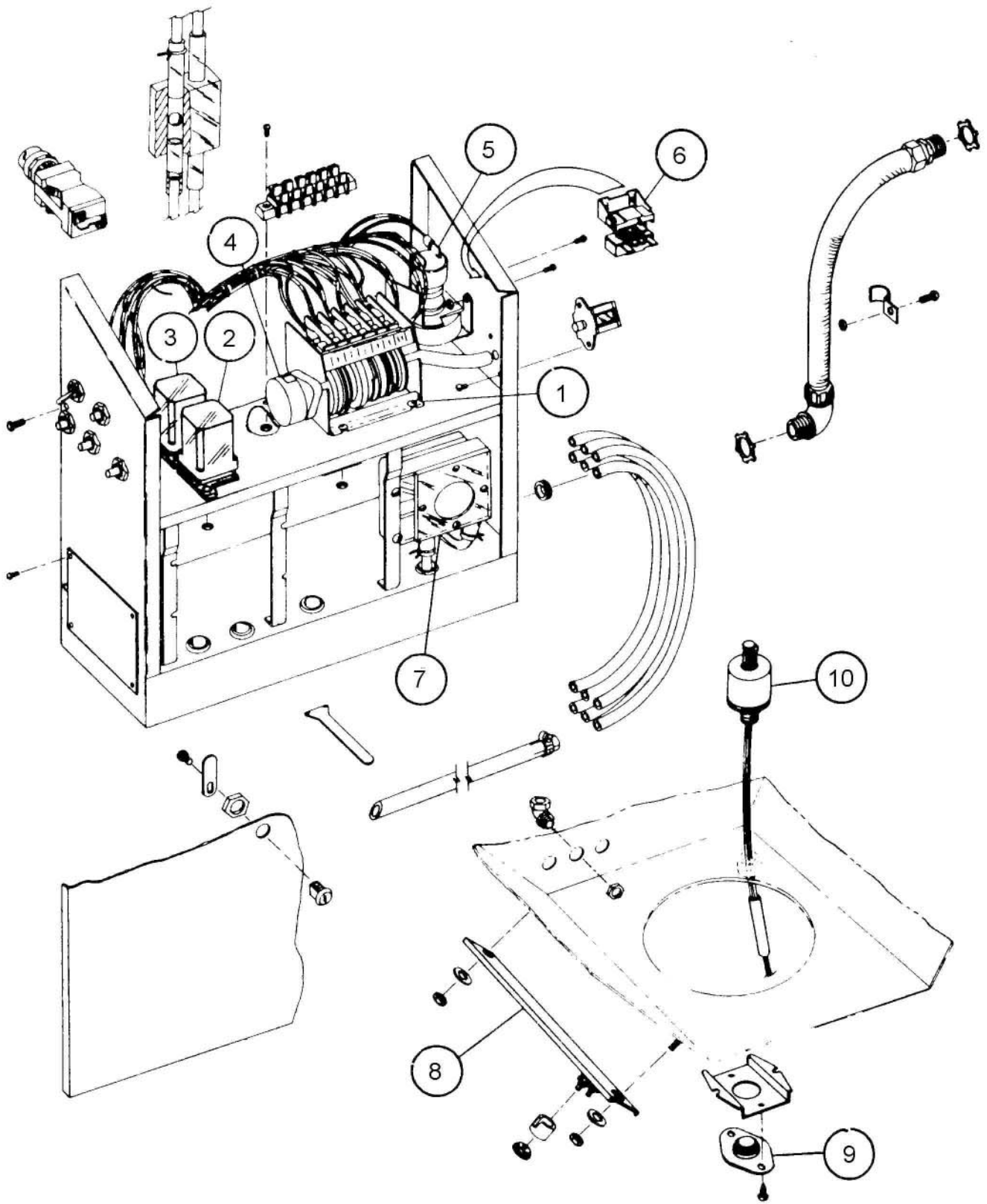

7.4.1 TIMER MOTOR (4) REPLACEMENT

1. Remove two mounting screws and nuts.
2. Pull motor to the left, away from timer frame until stopped by the pinion.
3. Slide motor up and forward so that motor shaft slides out slot in frame.
4. Disconnect wires and reconnect to new motor.
5. Replace motor in frame making sure that gear and pinion are meshed and that the motor is flush against the frame with the shaft bushing locked in place at the bottom of the slot

7.4.2 CAM ADJUSTMENT (See Figure 7.4.2)

The timer cams which control the water solenoid valve and chemical pumps are adjustable. These cams are split with a left and right side. The right side of the cam sets the point at which the solenoid valve opens or the chemical pump starts. The left side sets the point at which the solenoid valve closes or chemical pump stops.

**THE RIGHT SIDE OF CAM SHOULD
ALWAYS REMAIN AT FACTORY SETTING.**

Adjustment of the left side will determine the length of time the solenoid valve is open or the chemical pump operates and thus controls the amount of water or chemical introduced into the machine.

Cams are adjusted using a special wrench which fits into notches on the side of the cam.

The cart shows factory cam settings. The right side of adjustable cams should always be at factory setting but the left side may be changed to suit field conditions.

TIMER CYCLE 72 SECOND

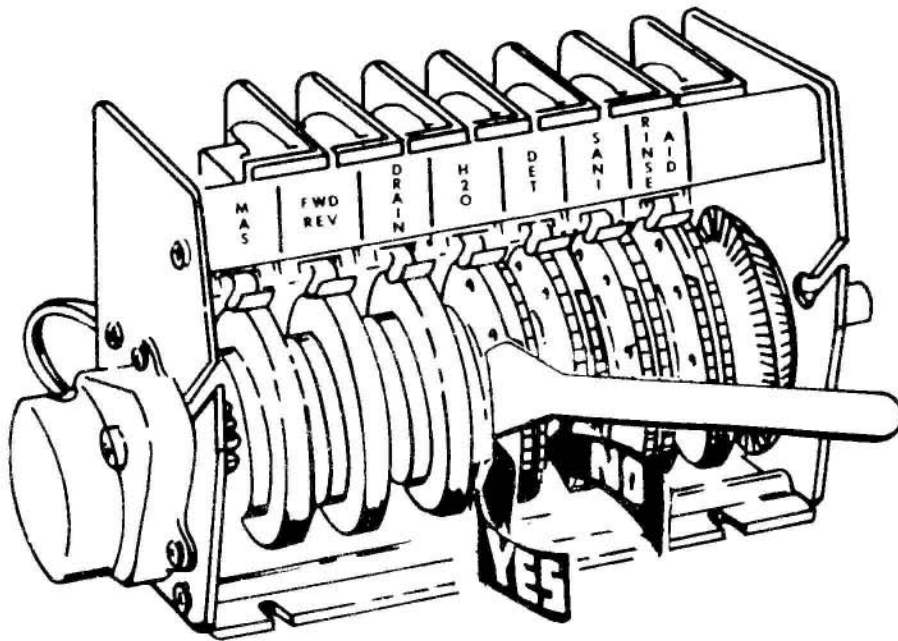
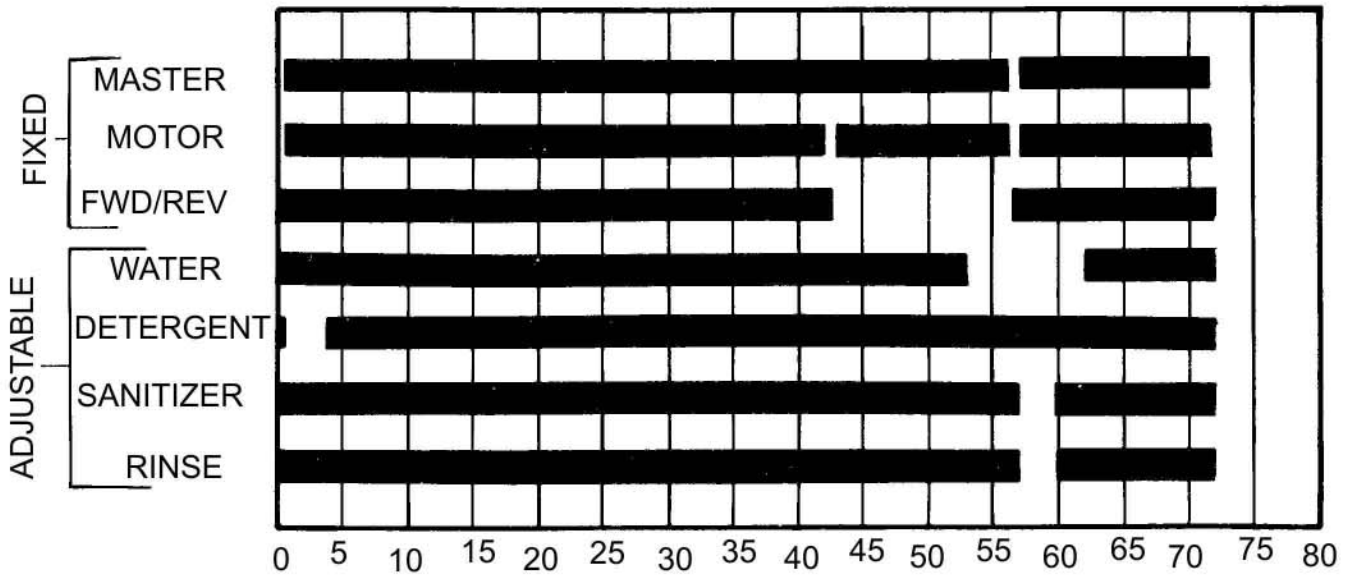

**ADJUST CAM FROM LEFT SIDE ONLY!
DO NOT MOVE OR ADJUST RIGHT SIDE
OF CAM.**

Figure 7.4.2

7.4.3 TIMER SWITCH REPLACEMENT

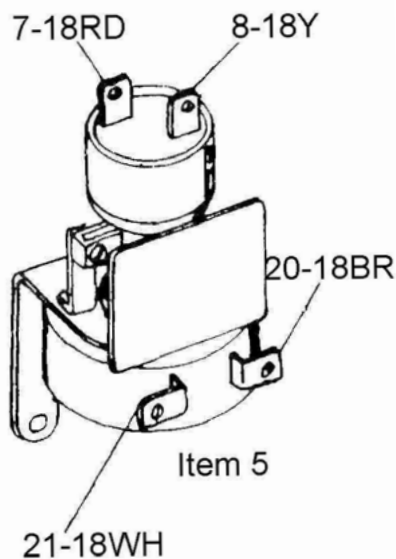

1. Remove small Phillips head screw which holds the timer switch bracket to the timer frame.
2. Move the switch straight to the rear away from the timer frame approximately 3/8 inch.
3. Separate the switch from its bracket and attach the bracket to the replacement switch.
4. Transfer wires one at a time from the old switch to the new switch.
5. Replace bracket and screw.

7.4.4 MOTOR RELAY REPLACEMENT

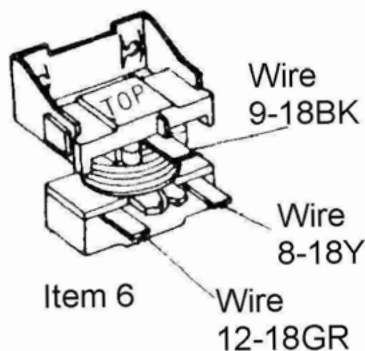

1. Remove four wires from the motor start relay (5).
2. Remove two screws and nuts which attach the motor relay to the cabinet side.
3. Install the new motor relay and attach wires.

7.4.5 REPLACEMENT OF START WINDING RELAY (6)

1. Remove the two screws which hold the relay bracket to the timer cabinet.
2. Attach new relay to the cabinet.
3. Remove wires one at a time from the old relay and reattach to the new relay.

CAUTION

Install relay in upright position!

Care must be taken to insure that wires are attached to this relay properly. Improper wiring will cause immediate motor burn out.

7.4.6 CHEMICAL PUMP REPLACEMENT

1. Loosen the two mounting screws which attach the chemical pump to its bracket.
2. Carefully remove the squeeze tube from the chemical intake and chemical discharge tubes.
3. Pull the pump (7) forward out of the cabinet and disconnect wires.
4. Reassemble in reverse order with the new pump.

7.4.7 HEATER REPLACEMENT

1. Remove motor compartment panel.
2. Remove attachment nuts and heater (8).
3. Remove ceramic insulating caps and disconnect wires.
4. Reassemble in reverse order.

7.4.8 THERMOSTAT REPLACEMENT

1. Remove motor compartment panel.
2. Remove two screws (1) which hold thermostat (9) to bracket.
3. Disconnect wires and attach to new thermostat.
4. Install new thermostat and screws.

"DELAVAL" Lettering
On Top

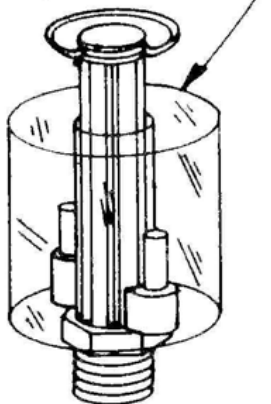

Item 10

7.4.9 FLOAT SWITCH REPLACEMENT

1. Remove motor compartment panel.
2. Disconnect two wires from float switch (10).

3. Remove clip and float.
4. Remove stem.
5. Reassemble in reverse order making sure that float is installed right side up.

7.4.10 POWER or CYCLE START SWITCH REPAIR (See Figure 7.4.10)

1. Disconnect wires from all four terminals.
2. Remove lens (1) from front of switch.
3. Remove collar (2).
4. Remove small gasket (3).
5. Remove remainder of switch assembly from the door.
6. To replace lamp transformer insert a screwdriver under the locking tabs on one side of the transformer (4) and then on the opposite side. Reverse steps 1 thru 5.
7. To replace switch operator insert screwdriver under locking tabs at the front of the switch and pry up. Do the same on the opposite side.
8. Install the operator. Reverse steps 1 thru 5.
9. Replace contact block (5).
 1. Insert a small screwdriver in the slot at the rear of the contact block and separate the blocks.
 2. Slide the blocks forward and backward, do not attempt to pry apart laterally.
 3. Assemble the new contact block (blocks) and insert the lamp holder from the front. Apply sufficient force to push lamp holder into place.
10. Reassemble in reverse order.

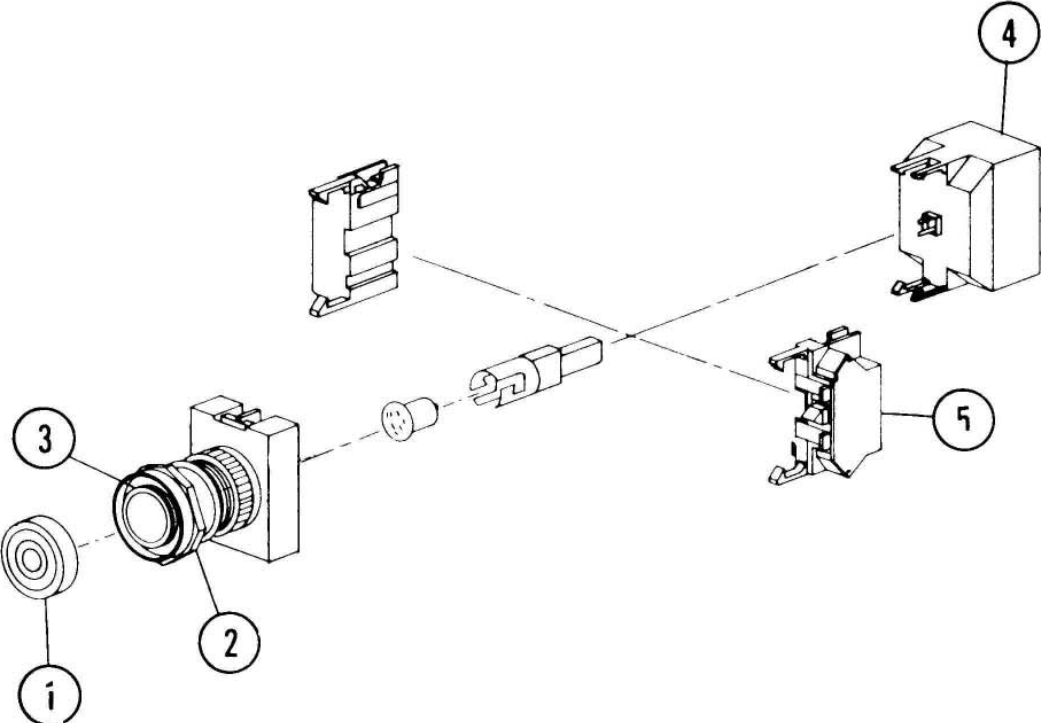

Figure 7.4.10

CAUTION

Flow indicators and chemical system contain caustic chemicals. Flush system and protect eyes before performing service.

7.4.11 CLEANING FLOW INDICATOR (11) (See Figure 7.4)

1. Remove chemical tubes from detergent and sanitizer containers and place in a container or clean water.
2. Operate both pumps using the prime switches until the chemical tubes are flushed and filled with clean water. If flow indicator still remains cloudy remove the silicone tubes from both ends and clean with rags and pipe cleaner.
3. Reassemble.

7.4.12 FLOW INDICATOR REPLACEMENT

1. Remove chemical suction tubes from chemical containers and place in clean water. Flush the system using the prime switches.
2. Remove silicone rubber tubes from both ends of the flow indicator and remove glass balls.
3. Remove screws attaching indicator to door.
4. Install new indicator reversing steps 1, 2, and 3.

7.5.0 FRESH WATER PLUMBING

(See Figure 7.5)

Fresh water is introduced into the machine through the fresh water plumbing assembly. A manual shut-off valve in the front compartment closes off the system when servicing is required on other components. Water flows from the shut-off valve through a strainer and into the water solenoid which controls water flow into the machine. A vacuum breaker provides back flow protection.

7.5.1 CLEAN/REPLACE STRAINER SCREEN

1. Remove strainer cap (1).
2. Remove screen and inspect.
3. Slightly open shut-off valve (2) to flush loose scale or dirt from the strainer housing.
4. If screen is clogged, soak in lime remover. If damaged, replace.
5. Reassemble in reverse order.

7.5.2 REPLACE SHUT-OFF VALVE PACKING

1. Shut off water supply upstream of machine.
2. Remove screw and lift off valve handle.
3. Using $\frac{3}{4}$ inch wrench, remove valve bonnet (3).
4. Disassemble stem, packing and plug.
5. Clean plug, stem and bonnet using lime remover and steel wool.
6. Install new packing and reassemble in reverse order.

FRESH WATER ASSEMBLY

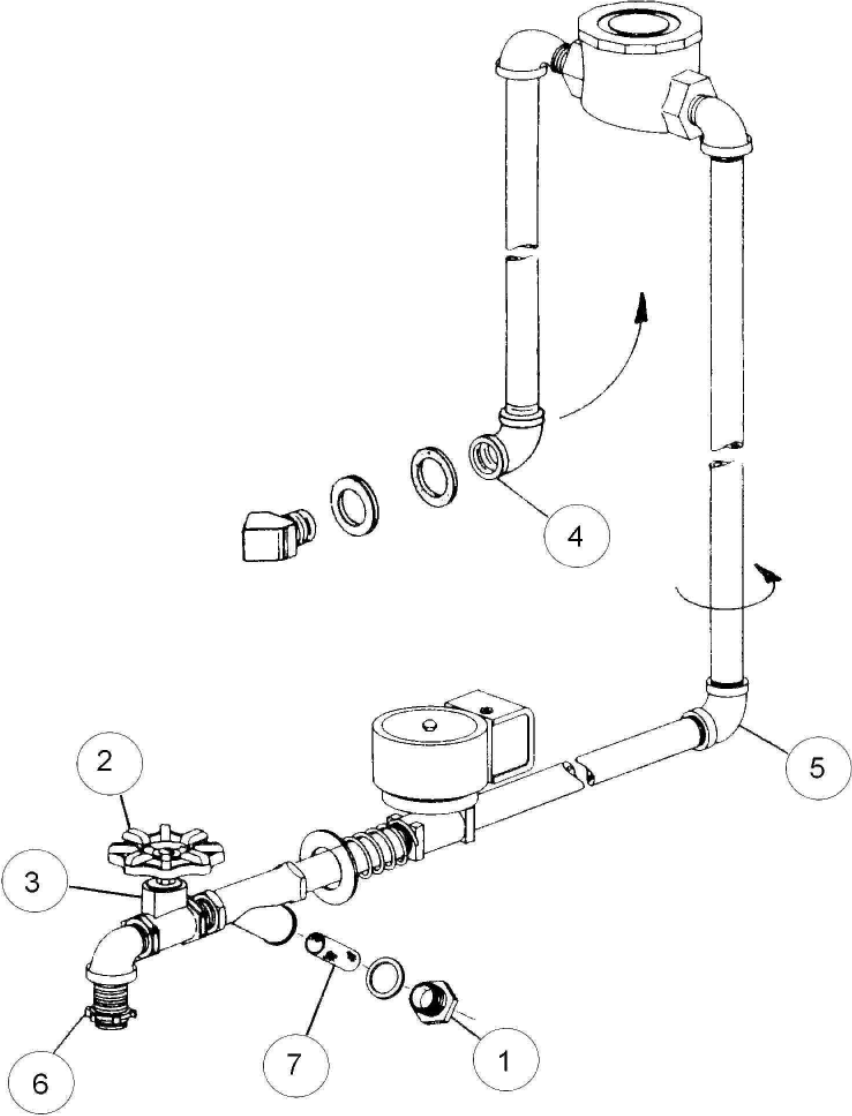

Figure 7.5

SOLENOID
ASSEMBLY

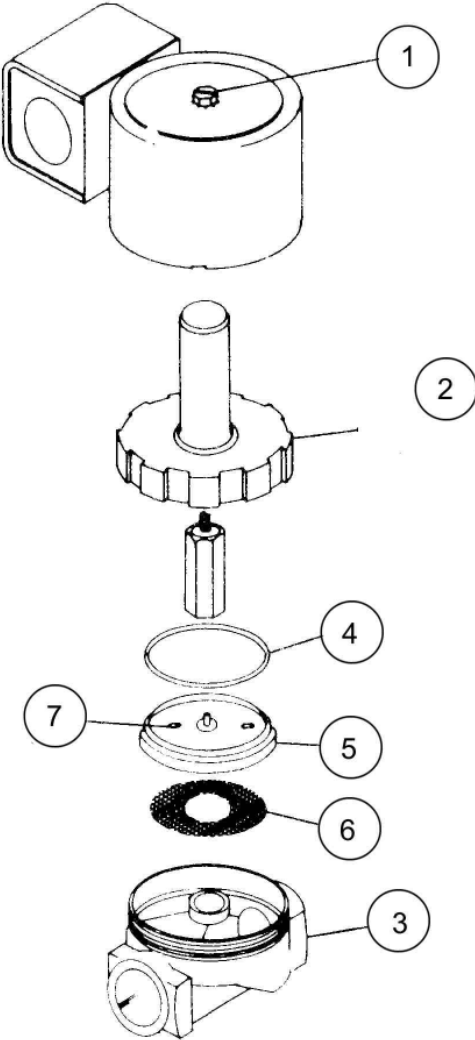

Figure 7.5.3

7.5.3 SERVICE SOLENOID VALVE DIAPHRAGM (See Figure 7.5.3)

1. Shut off water with manual valve.
2. Remove screw (1) and lift off solenoid.
3. Unscrew valve bonnet (2) using spanner or channel-locks. Insure that valve body (3) is held firmly to prevent damage to plumbing.
4. Remove bonnet (2), o-ring (4) and diaphragm (5).
5. Clean screen (6) and valve body.
6. Inspect bleeder holes (7) for plugging and diaphragm for damage.
7. Reassemble in reverse order using new parts from diaphragm kit.
8. Clean strainer screen (7). (See Figure 7.5)

7.5.4 REPLACE SOLENOID VALVE COIL (See Figure 7.5.3)

1. Remove screw (1) on top of solenoid coil housing.
2. Remove coil and housing.
3. Disassemble housing and replace coil.
4. Install housing on valve body and replace screw.

7.5.5 OVERHAUL VACUUM BREAKER (See Figure 7.5.5)

1. Remove cap by turning counter clockwise with channel-locks or pipe wrench.
2. Remove plunger (1) and gasket.
3. Clean gasket seat, plunger seat and stem using steel wool and lime remover.
4. Reassemble in reverse order using new plunger and gasket.

VACUUM BREAKER
ASSEMBLY

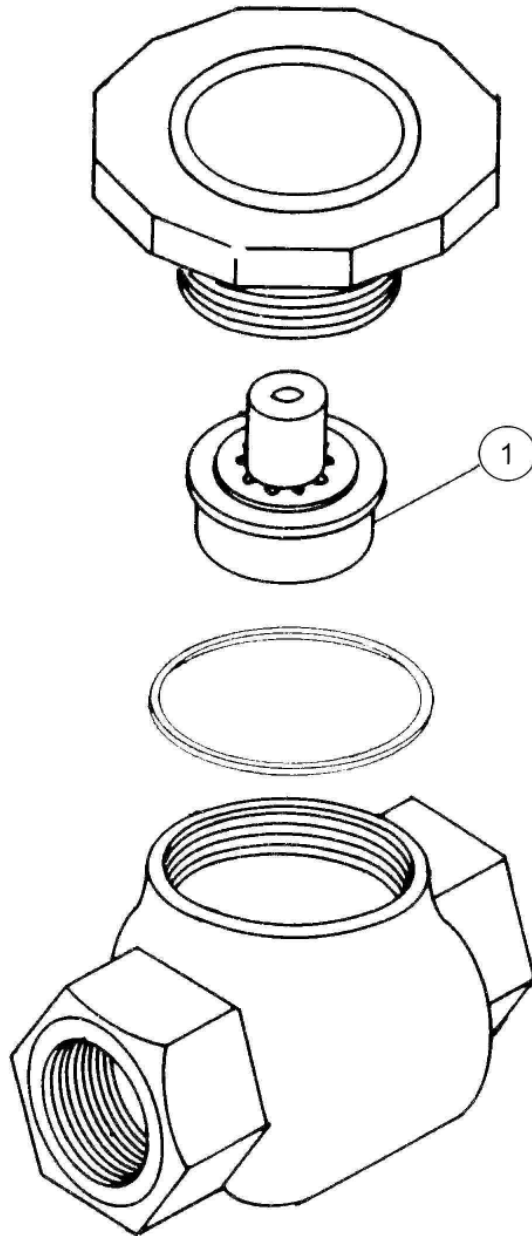

Figure 7.5.5

7.5.6 PLUMBING REMOVAL

(See Figure 7.5)

Most repairs on fresh water plumbing can be done without removing the plumbing assembly from the machine. However, when a valve or a strainer body must be replaced the plumbing must be completely disassembled and removed. The following procedure applies:

1. Remove 45° elbow, washer and gasket from inside the machine sump (4).
2. Rotate the pipe attached to the discharge at the vacuum breaker 90° to an upward direction as shown.
3. Using a pipe wrench rotate the vacuum breaker inlet pipe and remove this portion of the plumbing from the machine.
4. Remove the elbow (5).
5. Remove lock nut (6) on plumbing inlet.
6. Remove screw which attaches the gusset to the front sump panel.
7. Remove lower plumbing assembly from the machine.
8. Replace individual parts as required and reassemble in reverse order using teflon pipe fitting tape on all joints.