



Mission 3D Inverter Series

Service Manual 2014

MBSEU-A-1412



CONTENTS

1. Precaution	3
1.1 Safety Precaution.....	3
1.2 Warning	3
2. Function	6
3. Dimension	7
3.1 Indoor Unit.....	7
3.2 Outdoor Unit.....	10
4. Refrigerant Cycle Diagram	13
5 Installation Details	14
5.1 Wrench torque sheet for installation	14
5.2 Connecting the cables	14
5.3 Pipe length and the elevation	15
5.4 Installation for the first time	16
5.5 Adding the refrigerant after running the system for many years	17
5.6 Re-installation while the indoor unit need to be repaired	18
5.7 Re-installation while the outdoor unit need to be repaired	19
6. Operation Characteristics	21
7. Electronic function	22
7.1 Abbreviation	22
7.2 Display function.....	22
7.3 Main Protection	23
7.4 Operation Modes and Functions.....	24
8. Troubleshooting	28
8.1 Indoor Unit Error Display.....	29
8.2 Trouble shooting.....	30

1. Precaution

1.1 Safety Precaution

- To prevent injury to the user or other people and property damage, the following instructions must be followed.
- Incorrect operation due to ignoring instruction will cause harm or damage.
- Before service the unit, be sure to read this service manual at first.

1.2 Warning

➤ Installation

- Do not use a defective or underrated circuit breaker. Use this appliance on a dedicated circuit.
There is risk of fire or electric shock.
- For electrical work, contact the dealer, seller, a qualified electrician, or an authorized service center.
Do not disassemble or repair the product, there is risk of fire or electric shock.
- Always ground the product.
There is risk of fire or electric shock.
- Install the panel and the cover of control box securely.
There is risk of fire of electric shock.
- Always install a dedicated circuit and breaker.
Improper wiring or installation may cause fire or electric shock.
- Use the correctly rated breaker of fuse.
There is risk of fire or electric shock.
- Do not modify or extend the power cable.
There is risk of fire or electric shock.
- Do not install, remove, or reinstall the unit by yourself (customer).
There is risk of fire, electric shock, explosion, or injury.
- Be caution when unpacking and installing the product.

Sharp edges could cause injury, be especially careful of the case edges and the fins on the condenser and evaporator.

- For installation, always contact the dealer or an authorized service center.
- Do not install the product on a defective installation stand.
- Be sure the installation area does not deteriorate with age.
If the base collapses, the air conditioner could fall with it, causing property damage, product failure, and personal injury.
- Do not let the air conditioner run for a long time when the humidity is very high and a door or a window is left open.
- Take care to ensure that power cable could not be pulled out or damaged during operation.
There is risk of fire or electric shock.
- Do not place anything on the power cable.
There is risk of fire or electric shock.
- Do not plug or unplug the power supply plug during operation.
There is risk of fire or electric shock.
- Do not touch (operation) the product with wet hands.
- Do not place a heater or other appliance near the power cable.
There is risk of fire and electric shock.
- Do not allow water to run into electrical parts.
It may cause fire, failure of the product, or electric shock.
- Do not store or use flammable gas or combustible near the product.
There is risk of fire or failure of product.
- Do not use the product in a tightly closed space for a long time.
Oxygen deficiency could occur.
- When flammable gas leaks, turn off the gas and open a window for ventilation before turn the product on.
- If strange sounds or smoke comes from product, turn the breaker off or disconnect the power supply cable.

There is risk of electric shock or fire.

■ **Stop operation and close the window in storm or hurricane. If possible, remove the product from the window before the hurricane arrives.**

There is risk of property damage, failure of product, or electric shock.

■ **Do not open the inlet grill of the product during operation. (Do not touch the electrostatic filter, if the unit is so equipped.)**

There is risk of physical injury, electric shock, or product failure.

■ **When the product is soaked, contact an authorized service center.**

There is risk of fire or electric shock.

■ **Be caution that water could not enter the product.**

There is risk of fire, electric shock, or product damage.

■ **Ventilate the product from time to time when operating it together with a stove etc.**

There is risk of fire or electric shock.

■ **Turn the main power off when cleaning or maintaining the product.**

There is risk of electric shock.

■ **When the product is not be used for a long time, disconnect the power supply plug or turn off the breaker.**

There is risk of product damage or failure, or unintended operation.

■ **Take care to ensure that nobody could step on or fall onto the outdoor unit.**

This could result in personal injury and product damage.

➤ CAUTION

■ **Always check for gas (refrigerant) leakage after installation or repair of product.**

Low refrigerant levels may cause failure of product.

■ **Install the drain hose to ensure that water is drained away properly.**

A bad connection may cause water leakage.

■ **Keep level even when installing the**

product.

It can avoid vibration of water leakage.

■ **Do not install the product where the noise or hot air from the outdoor unit could damage the neighborhoods.**

It may cause a problem for your neighbors.

■ **Use two or more people to lift and transport the product.**

■ **Do not install the product where it will be exposed to sea wind (salt spray) directly.**

It may cause corrosion on the product.

Corrosion, particularly on the condenser and evaporator fins, could cause product malfunction or inefficient operation.

➤ Operational

■ **Do not expose the skin directly to cool air for long time. (Do not sit in the draft).**

■ **Do not use the product for special purposes, such as preserving foods, works of art etc. It is a consumer air conditioner, not a precision refrigerant system.**

There is risk of damage or loss of property.

■ **Do not block the inlet or outlet of air flow.**

■ **Use a soft cloth to clean. Do not use harsh detergents, solvents, etc.**

There is risk of fire, electric shock, or damage to the plastic parts of the product.

■ **Do not touch the metal parts of the product when removing the air filter. They are very sharp.**

■ **Do not step on or put anything on the product. (outdoor units)**

■ **Always insert the filter securely. Clean the filter every two weeks or more often if necessary.**

A dirty filter reduces the efficiency of the air conditioner and could cause product malfunction or damage.

■ **Do not insert hands or other objects through air inlet or outlet while the product is operated.**

■ **Do not drink the water drained from the product.**

■ **Use a firm stool or ladder when cleaning or maintaining the product.**

Be careful and avoid personal injury.

■ **Replace the all batteries in the remote control with new ones of the same type. Do not mix old and new batteries or different types of batteries.**

There is risk of fire or explosion.

■ **Do not recharge or disassemble the batteries. Do not dispose of batteries in a fire.**

They may burn or explode.

■ **If the liquid from the batteries gets onto your skin or clothes, wash it well with clean water. Do not use the remote if the batteries have leaked.**

2. Function

Model Names of Indoor/Outdoor Units

	Capacity	Indoor units	Outdoor units
3D inverter	9k	MSMBAU-09HRFN1-QRD0GW	MOB01-09HFN1-QRD0GW
	12k	MSMBBU-12HRFN1-QRD0GW	MOB01-12HFN1-QRD0GW
	18k	MSMBCU-18HRFN1-QRD0GW	MOB01-18HFN1-QRD0GW
	24k	MSMBDU-24HRFN1-QRD0GW	MOF2-24HFN1-QRD0GW

3. Dimension

3.1 Indoor Unit

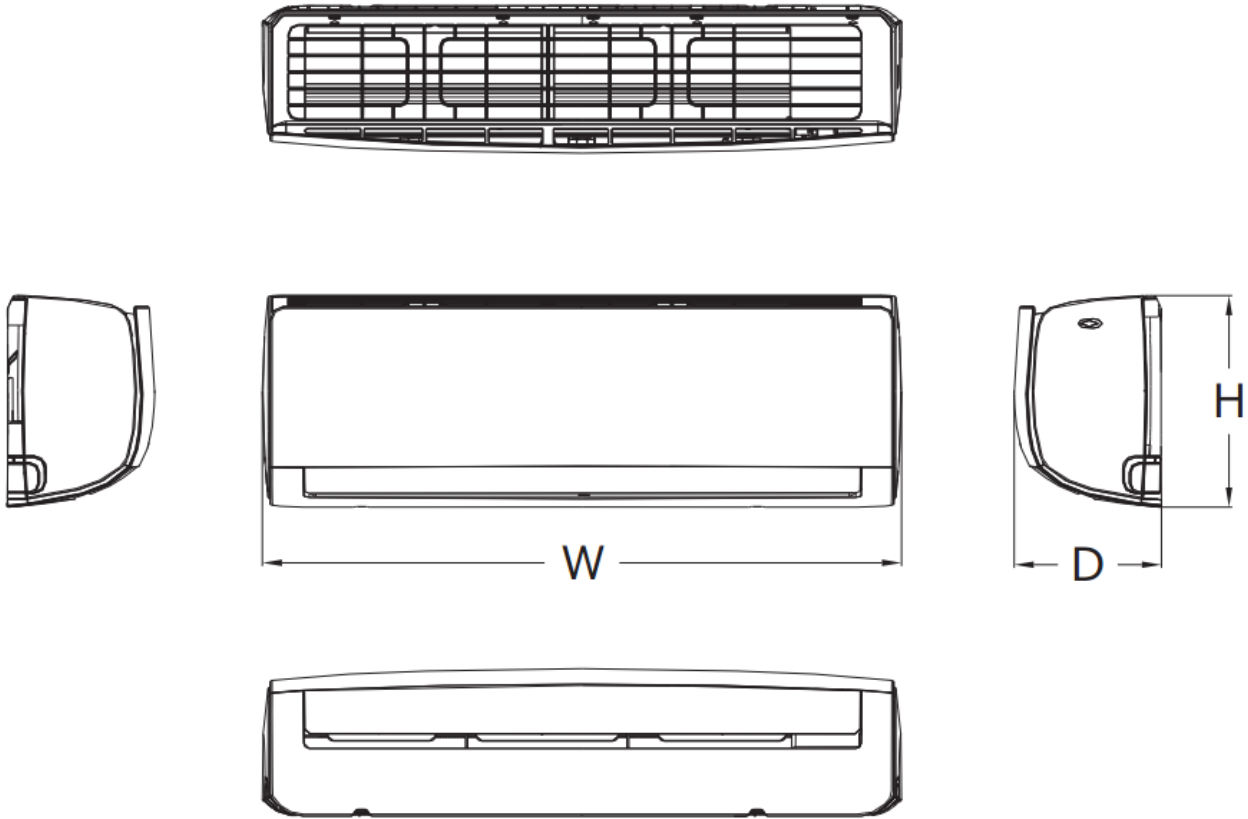

Model	W	D	H
MSMBAU-09HRFN1-QRD0GW	730	198	293
MSMBBU-12HRFN1-QRD0GW	810	200	300
MSMBCU-18HRFN1-QRD0GW	980	225	325
MSMBDU-24HRFN1-QRD0GW	1090	235	338

For MSMBAU-09HRFN1-QRD0GW:

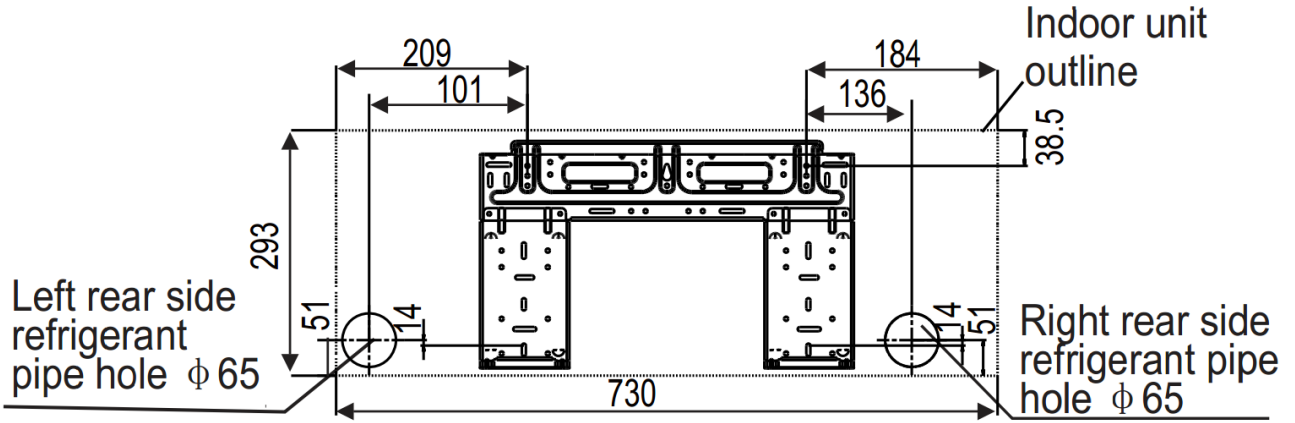

For MSMBBU-12HRFN1-QRD0GW:

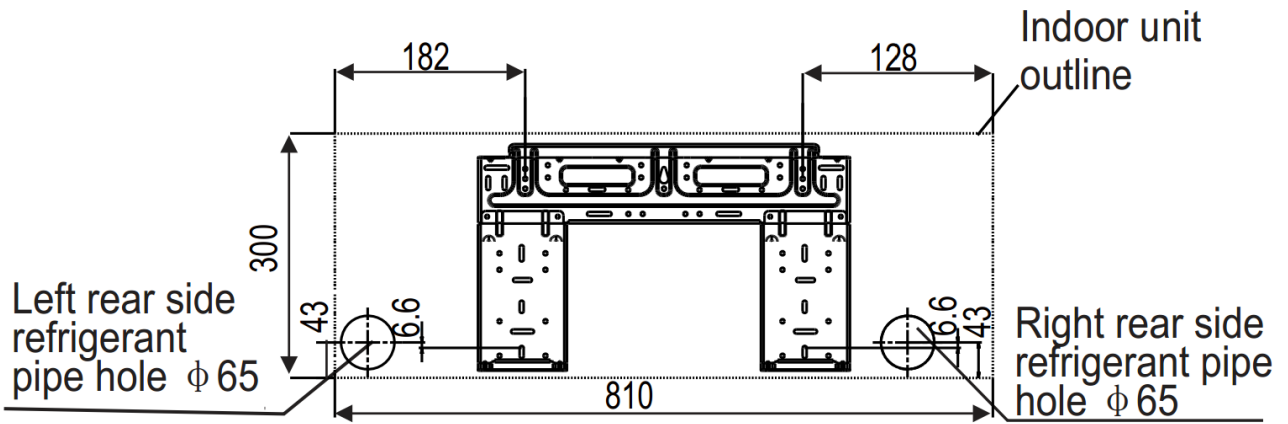

For MSMBUCU-18HRFN1-QRD0GW:

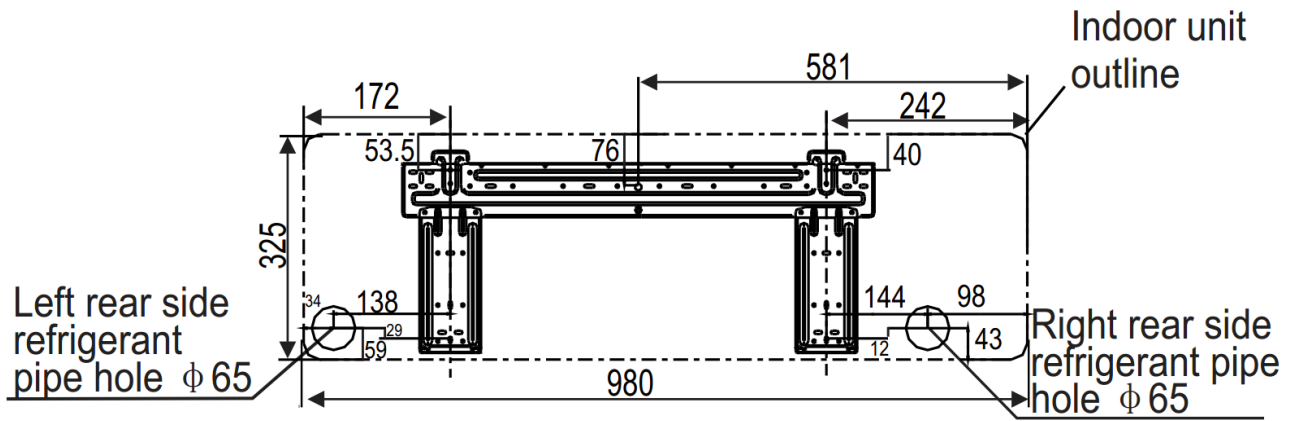

For MSMBDU-24HRFN1-QRD0GW:

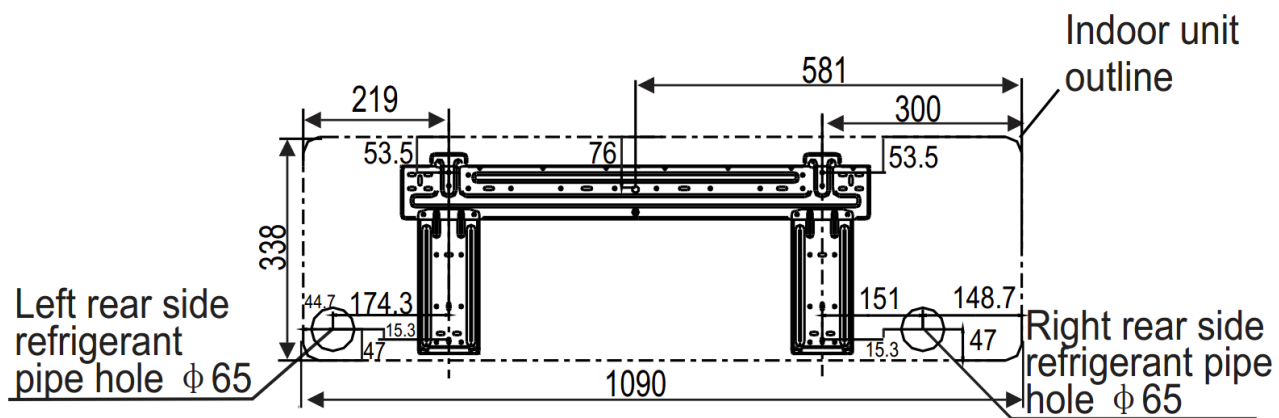

3.2 Outdoor Unit

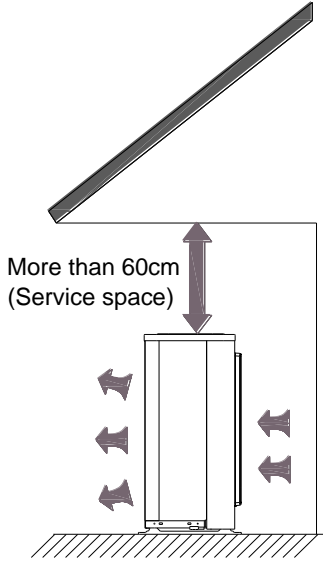
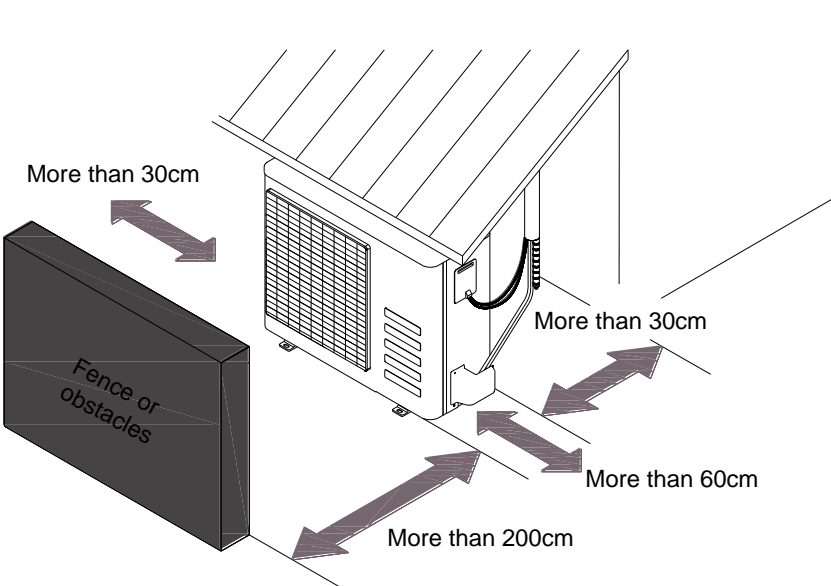

For MOB01-09HFN1-QRD0GW, MOB01-12HFN1-QRD0GW, MOB01-18HFN1-QRD0GW,

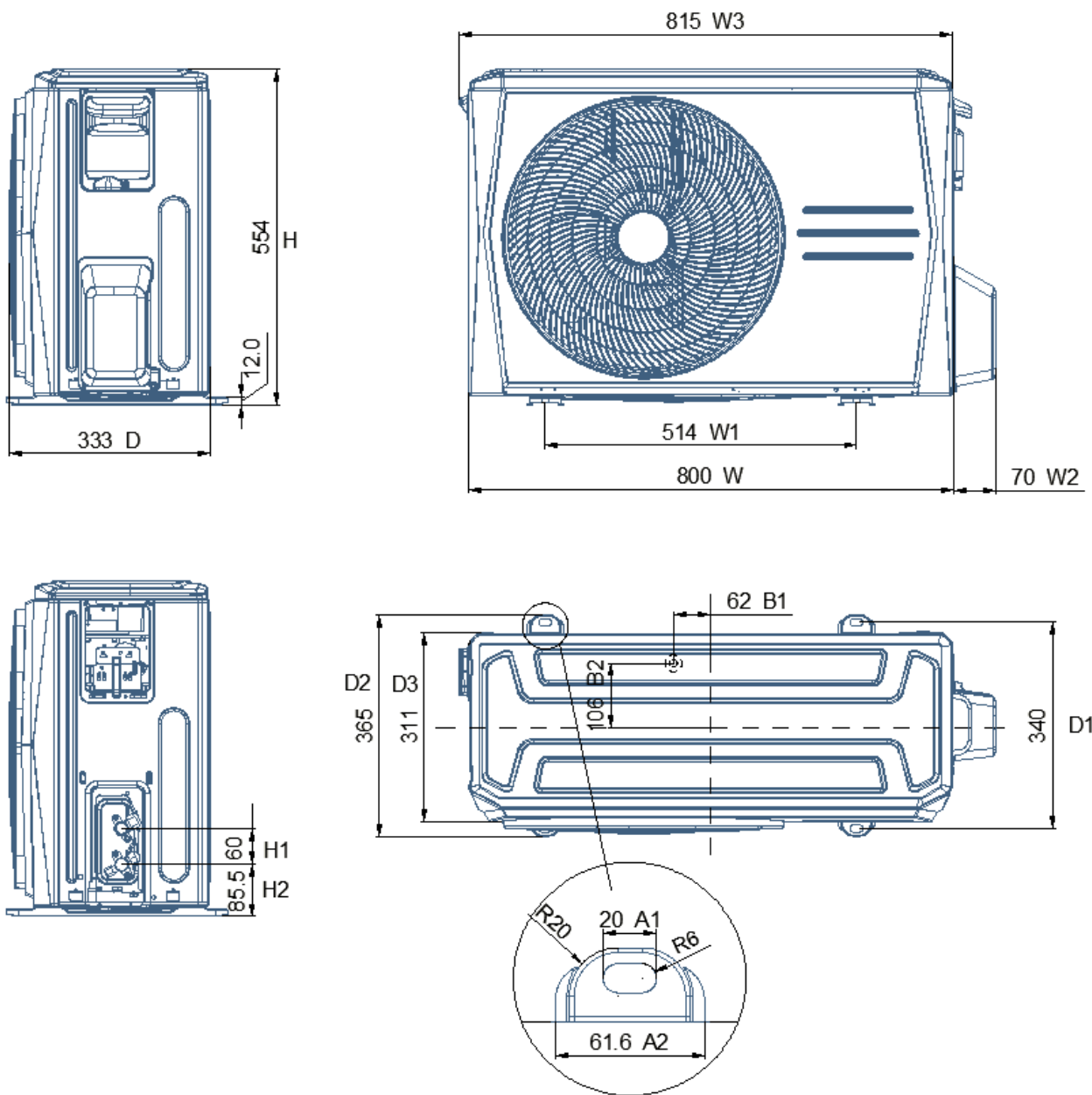

For **MOF2-24HFN1-QRD0GW**,

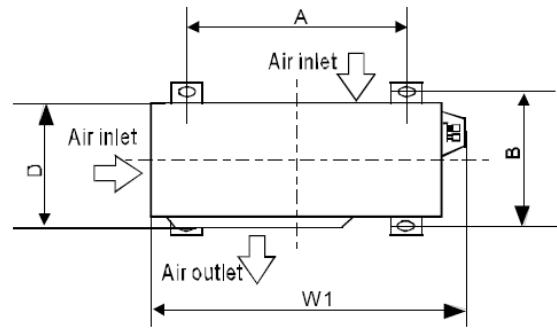
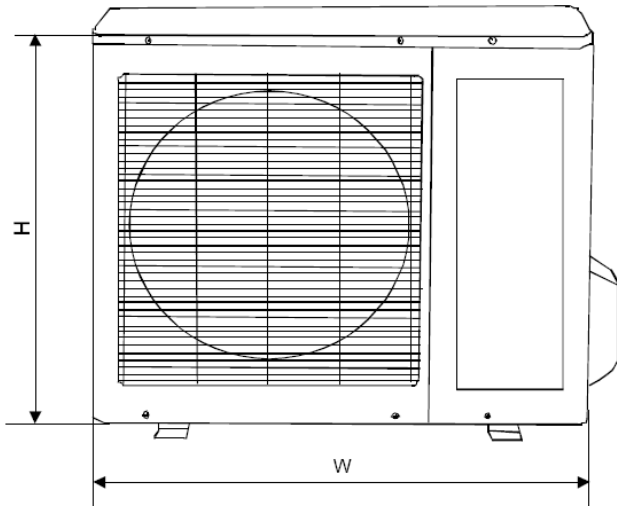

Model	W	D	H	W1	A	B
MOF2-24HFN1-QRD0GW	845	320	700	908	560	335

4. Refrigerant Cycle Diagram

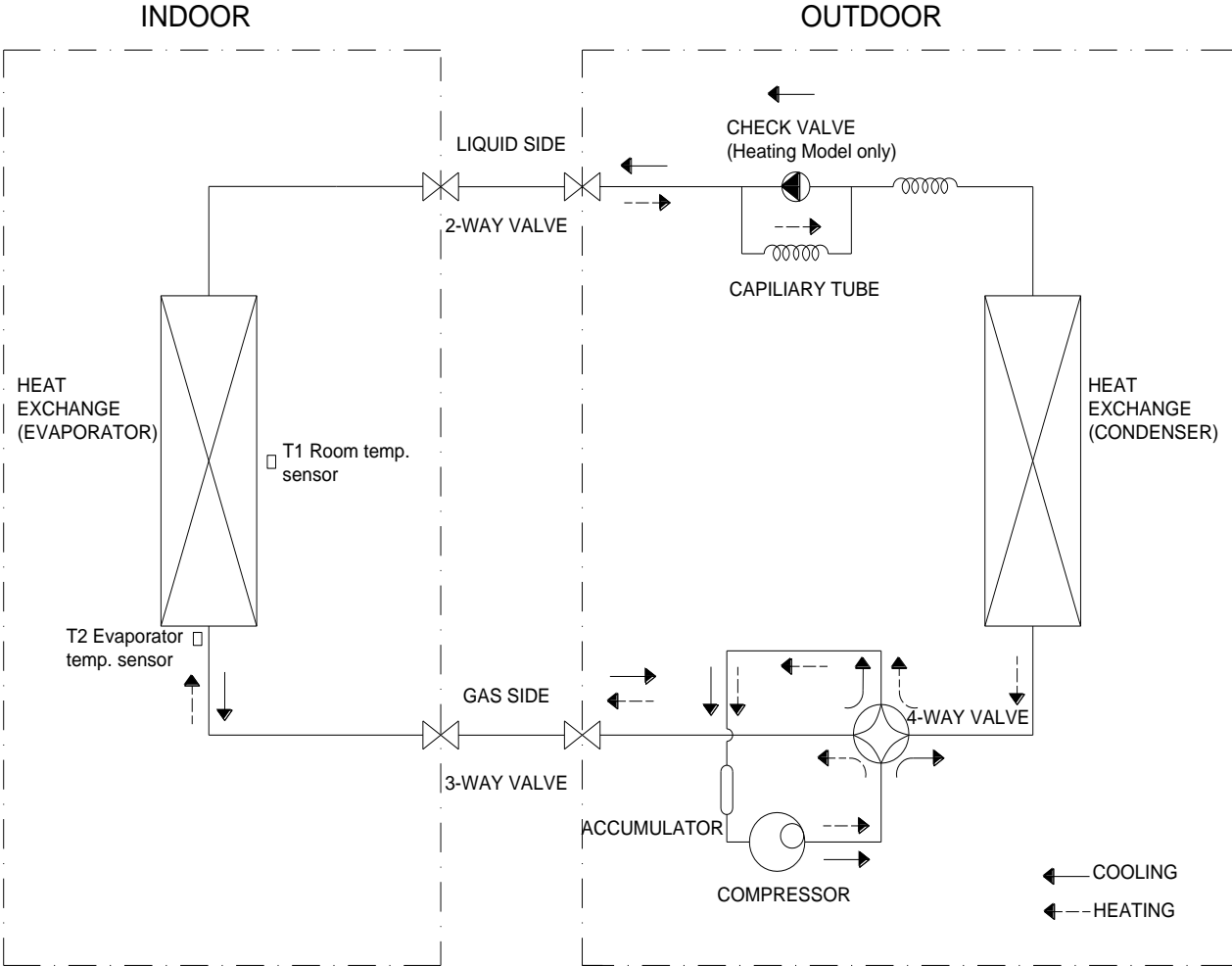

5 Installation Details

5.1 Wrench torque sheet for installation

Outside diameter		Torque	Additional tightening torque
mm	inch	N.cm	N.cm
Φ6.35	1/4	1500(153kgf.cm)	1600(163kgf.cm)
Φ9.52	3/8	2500(255kgf.cm)	2600(265kgf.cm)
Φ12.7	1/2	3500(357kgf.cm)	3600(367kgf.cm)
Φ15.9	5/8	4500(459kgf.cm)	4700(479kgf.cm)
Φ19	3/4	6500(663kgf.cm)	6700(683kgf.cm)

5.2 Connecting the cables

The power cord of connect should be selected according to the following specifications sheet.

Rated current of appliance	Nominal cross-sectional area (mm ²)
>3 and ≤6	0.75
>6 and ≤10	1
>10 and ≤16	1.5
>16 and ≤25	2.5

The cable size and the current of the fuse or switch are determined by the maximum current indicated on the nameplate which located on the side panel of the unit. Please refer to the nameplate before selecting the cable, fuse and switch.

5.3 Pipe length and the elevation

The pipe length and refrigerant amount:

Model	Pipe size		Standard length (m)	Max. Elevation B (m)	Max. Length A (m)	Additional refrigerant (g/m)
	Gas	Liquid				
MSMBAU-09HRFN1-QRD0GW + MOB01-09HFN1-QRD0GW	3/8" (Φ9.52)	1/4" (Φ6.35)	5	10	25	15
MSMBBU-12HRFN1-QRD0GW + MOB01-12HFN1-QRD0GW	3/8" (Φ9.52)	1/4" (Φ6.35)	5	10	25	15
MSMBCU-18HRFN1-QRD0GW + MOB01-18HFN1-QRD0GW	1/2" (Φ12.7)	1/4" (Φ6.35)	5	20	30	15
MSMBDU-24HRFN1-QRD0GW + MOF2-24HFN1-QRD0GW	5/8" (Φ15.9)	3/8" (Φ9.52)	5	25	50	30

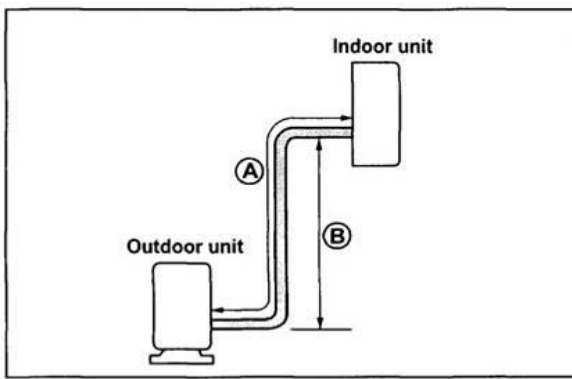

Caution:

The capacity test is based on the standard length and the maximum permissible length is based on the system reliability.

5.4 Installation for the first time

Air and moisture in the refrigerant system have undesirable effects as below:

- Pressure in the system rises.
- Operating current rises.
- Cooling or heating efficiency drops.
- Moisture in the refrigerant circuit may freeze and block capillary tubing.
- Water may lead to corrosion of parts in the refrigerant system.

Therefore, the indoor units and the pipes between indoor and outdoor units must be leak tested and evacuated to remove gas and moisture from the system.

Gas leak check (Soap water method):

Apply soap water or a liquid neutral detergent on the indoor unit connections or outdoor unit connections by a soft brush to check for leakage of the connecting points of the piping. If bubbles come out, the pipes have leakage.

1. Air purging with vacuum pump

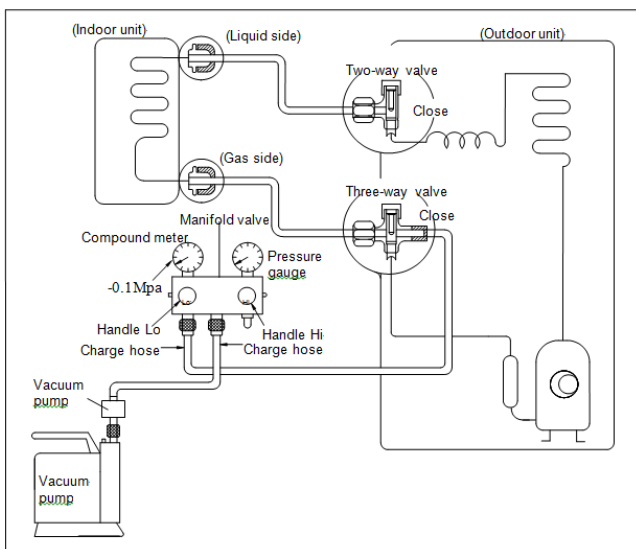

- 1) Completely tighten the flare nuts of the indoor and outdoor units, confirm that both the 2-way and 3-way valves are set to the closed position.
- 2) Connect the charge hose with the push pin of handle lo to the 3-way valves gas service port..
- 3) Connect the charge hose of handle hi connection to the vacuum pump.

- 4) Fully open the handle Lo of the manifold valve.
- 5) Operate the vacuum pump to evacuate.
- 6) Make evacuation for 30 minutes and check whether the compound meter indicates -0.1Mpa. If the meter does not indicate -0.1Mpa after pumping 30 minutes, it should be pumped 20 minutes more. If the pressure can't achieve -0.1Mpa after pumping 50 minutes, please check if there are some leakage points.

Fully close the handle Lo valve of the manifold valve and stop the operation of the vacuum pump. Confirm that the gauge needle does not move (approximately 5 minutes after turning off the vacuum pump).

- 7) Turn the flare nut of the 3-way valves about 45° counterclockwise for 6 or 7seconds after the gas

coming out, then tighten the flare nut again. Make sure the pressure display in the pressure indicator is a little higher than the atmosphere pressure. Then remove the charge hose from the 3 way valve.

- 8) Fully open the 2 way valve and 3 way valve and securely tighten the cap of the 3 way valve.

2. Air purging by refrigerant

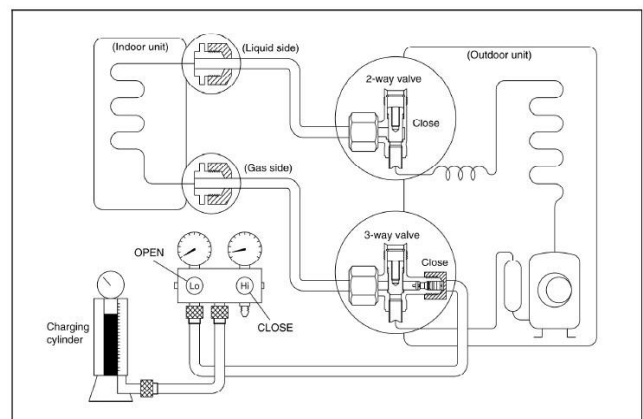

Procedure:

- 1). Confirm that both the 2-way and 3-way valves are set to the closed position.
- 2). Connect the charge set and a charging cylinder to the service port of the 3-way valve.
- 3). Air purging.
Open the valves on the charging cylinder and the

charge set. Purge the air by loosening the flare nut on the 2-way valve approximately 45' for 3 seconds then closing it for 1 minute; repeat 3 times.

After purging the air, use a torque wrench to tighten the flare nut on the 2-way valve.

4). Check the gas leakage.

Check the flare connections for gas leakage.

5). Discharge the refrigerant.

Close the valve on the charging cylinder and discharge the refrigerant by loosening the flare nut on the 2-way valve approximately 45' until the gauge indicates 0.3 to 0.5 Mpa.

6). Disconnect the charge set and the charging cylinder, and set the 2-way and 3-way valves to the open position.

Be sure to use a hexagonal wrench to operate the valve stems.

7). Mount the valve stems nuts and the service port cap.

Be sure to use a torque wrench to tighten the service port cap to a torque 18N·m.

Be sure to check the gas leakage.

3. Adding the refrigerant if the pipe length >5m

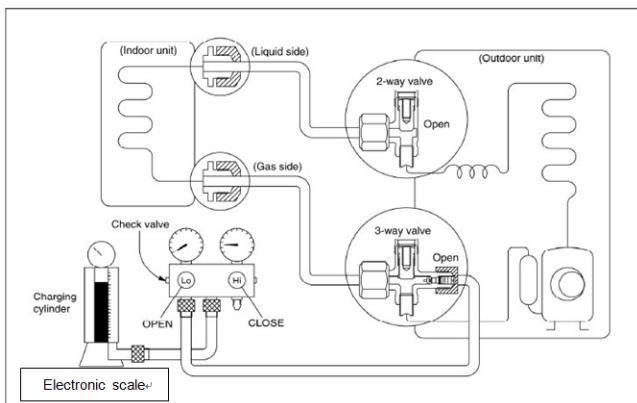

Procedure:

1). Connect the charge hose to the charging cylinder, open the 2-way valve and the 3-way valve.

Connect the charge hose which you disconnected from the vacuum pump to the valve at the bottom of the cylinder. If the refrigerant is R410A, make the cylinder bottom up to ensure the liquid charge.

2). Purge the air from the charge hose.

Open the valve at the bottom of the cylinder

and press the check valve on the charge set to purge the air (be careful of the liquid refrigerant).

3) Put the charging cylinder onto the electronic scale and record the weight.

4) Operate the air conditioner at the cooling mode.

5) Open the valves (Low side) on the charge set and charge the system with liquid refrigerant.

6).When the electronic scale displays the proper weight (refer to the table), disconnect the charge hose from the 3-way valve's service port immediately and turn off the air conditioner before disconnecting the hose.

7). Mount the valve stem caps and the service port

Use torque wrench to tighten the service port cap to a torque of 18N.m.

Be sure to check for gas leakage.

5.5 Adding the refrigerant after running the system for many years

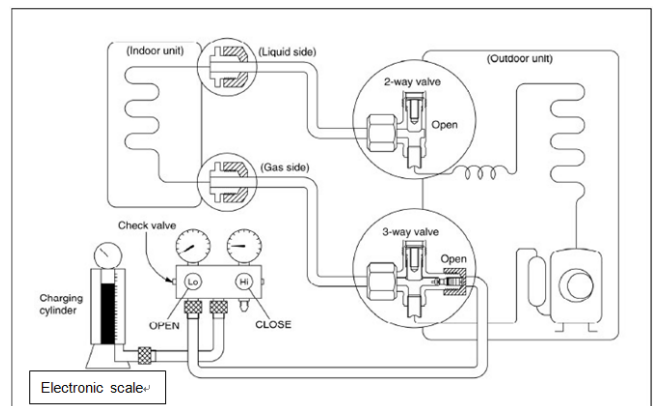

Procedure:

1). Connect the charge hose to the 3-way service port, open the 2-way valve and the 3-way valve. Connect the charge hose to the valve at the bottom of the cylinder. If the refrigerant is R410A, make the cylinder bottom up to ensure liquid charge.

2). Purge the air from the charge hose.

Open the valve at the bottom of the cylinder and press the check valve on the charge set to purge the air (be careful of the liquid refrigerant).

3) Put the charging cylinder onto the electronic scale and record the weight.

- 4) Operate the air conditioner at the cooling mode.
- 5) Open the valves (Low side) on the charge set and charge the system with liquid refrigerant.
- 6) When the electronic scale displays the proper weight (refer to the gauge and the pressure of the low side), disconnect the charge hose from the 3-way valve's service port immediately and turn off the air conditioner before disconnecting the hose.
- 7). Mount the valve stem caps and the service port

Use torque wrench to tighten the service port cap to a torque of 18N.m.
Be sure to check for gas leakage.

5.6 Re-installation while the indoor unit need to be repaired

1. Collecting the refrigerant into the outdoor unit

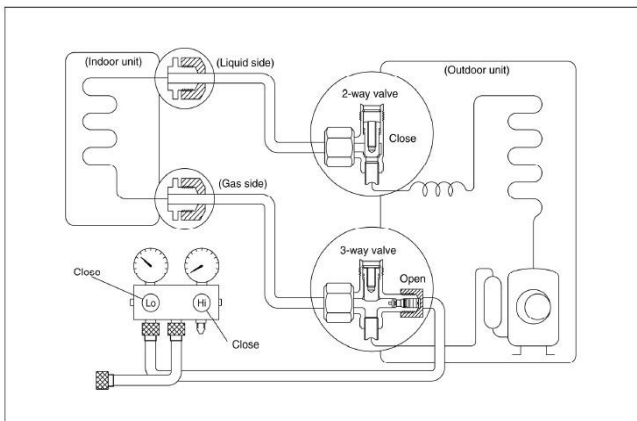

Procedure

- 1). Confirm that both the 2-way and 3-way valves are set to the opened position
Remove the valve stem caps and confirm that the valve stems are in the opened position.
Be sure to use a hexagonal wrench to operate the valve stems.
- 2). Connect the charge hose with the push pin of handle Lo to the 3-way valves gas service port.
- 3). Air purging of the charge hose.
Open the handle Lo valve of the manifold valve slightly to purge air from the charge hose for 5 seconds and then close it quickly.
- 4). Set the 2-way valve to the close position.
- 5). Operate the air conditioner at the cooling cycle

and stop it when the gauge indicates 0.1MPa.
6). Set the 3-way valve to the closed position immediately

Do this quickly so that the gauge ends up indicating 0.3 to 0.5Mpa.

Disconnect the charge set, and tighten the 2-way and 3-way valve's stem nuts.

Use a torque wrench to tighten the 3-way valves service port cap to a torque of 18N.m.

Be sure to check for gas leakage.

2. Air purging by the refrigerant

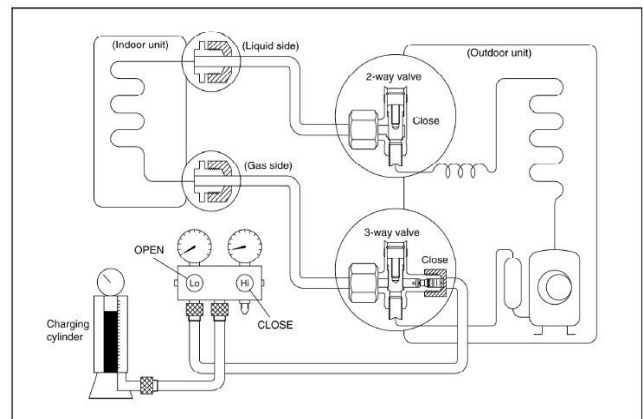

Procedure:

- 1). Confirm that both the 2-way and 3-way valves are set to the closed position.
- 2). Connect the charge set and a charging cylinder to the service port of the 3-way valve
Leave the valve on the charging cylinder closed.
- 3). Air purging.

Open the valves on the charging cylinder and the charge set. Purge the air by loosening the flare nut on the 2-way valve approximately 45' for 3 seconds then closing it for 1 minute; repeat 3 times.

After purging the air, use a torque wrench to tighten the flare nut on the 2-way valve.

- 4). Check the gas leakage

Check the flare connections for gas leakage.

- 5). Discharge the refrigerant.

Close the valve on the charging cylinder and discharge the refrigerant by loosening the flare nut on the 2-way valve approximately 45' until the gauge indicates 0.3 to 0.5 Mpa.

- 6). Disconnect the charge set and the charging cylinder, and set the 2-way and 3-way valves to the open position

Be sure to use a hexagonal wrench to operate the valve stems.

7). Mount the valve stems nuts and the service port cap

Be sure to use a torque wrench to tighten the service port cap to a torque 18N.m.

Be sure to check the gas leakage.

5.7 Re-installation while the outdoor unit need to be repaired

1. Evacuation for the whole system

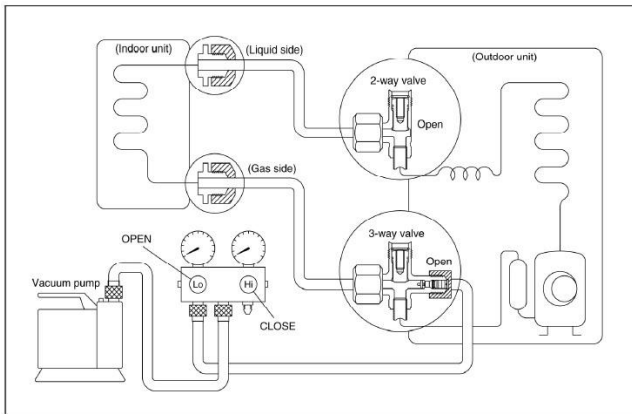

Procedure:

- 1). Confirm that both the 2-way and 3-way valves are set to the opened position.
- 2). Connect the vacuum pump to 3-way valve's service port.
- 3). Evacuation for approximately one hour. Confirm that the compound meter indicates -0.1Mpa.
- 4). Close the valve (Low side) on the charge set, turn off the vacuum pump, and confirm that the gauge needle does not move (approximately 5 minutes after turning off the vacuum pump).
- 5). Disconnect the charge hose from the vacuum pump.

2. Refrigerant charging

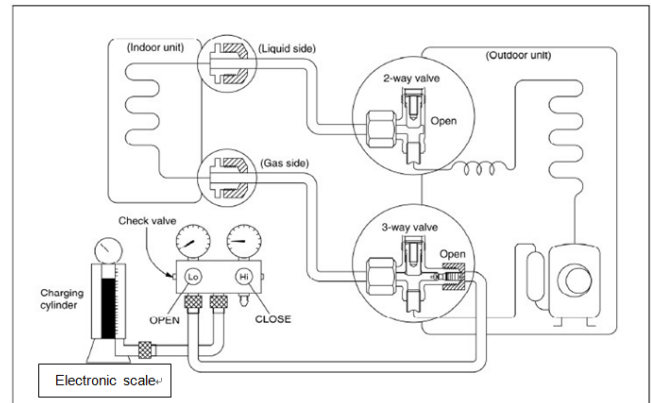

Procedure:

- 1). Connect the charge hose to the charging cylinder, open the 2-way valve and the 3-way valve

Connect the charge hose which you disconnected from the vacuum pump to the valve at the bottom of the cylinder. If the refrigerant is R410A, make the cylinder bottom up to ensure liquid charge.

- 2). Purge the air from the charge hose
Open the valve at the bottom of the cylinder and press the check valve on the charge set to purge the air (be careful of the liquid refrigerant).
- 3) Put the charging cylinder onto the electronic scale and record the weight.
- 4). Open the valves (Low side) on the charge set and charge the system with liquid refrigerant
If the system cannot be charge with the specified amount of refrigerant, or can be charged with a little at a time (approximately 150g each time) , operating the air conditioner in the cooling cycle; however, one time is not sufficient, wait approximately 1 minute and then repeat the procedure.
- 5).When the electronic scale displays the proper weight, disconnect the charge hose from the 3-way valve's service port immediately
If the system has been charged with liquid refrigerant while operating the air conditioner, turn off the air conditioner before disconnecting the hose.
- 6). Mounted the valve stem caps and the service port
Use torque wrench to tighten the service port cap to a torque of 18N.m.

Be sure to check for gas leakage

6. Operation Characteristics

Mode Temperature	Cooling operation	Heating operation	Drying operation
Room temperature	17°C~32°C (62°F~90°F)	0°C~30°C (32°F~86°F)	10°C~32°C (50°F~90°F)
Outdoor temperature	0°C~50°C (32°F~122°F)	-20°C~30°C (-4°F~86°F)	0°C~50°C (32°F~122°F)
	-15°C~50°C (5°F~122°F) (For the models with low temperature cooling system)		

CAUTION:

1. If the air conditioner is used beyond the above conditions, certain safety protection features may come into operation and cause the unit to operate abnormally.
2. The room relative humidity should be less than 80%. If the air conditioner operates beyond this figure, the surface of the air conditioner may attract condensation. Please set the vertical air flow louver to its maximum angle (vertically to the floor), and set HIGH fan mode.
3. The optimum performance will be achieved during this operating temperature zone.

7. Electronic function

7.1 Abbreviation

- T1: Indoor room temperature
- T2: Coil temperature of evaporator
- T3: Coil temperature of condenser
- T4: Outdoor ambient temperature
- T5: Compressor discharge temperature

7.2 Display function

7.2.1 Icon explanation on indoor display board.



Digital display:

Displays the temperature settings when the air conditioner is operational.

Displays the room temperature in FAN mode.

Displays the self-diagnostic codes.

Displays '00' for three seconds when Timer ON, Fresh, Swing, Turbo or Silence feature is activated.

Displays 'DF' for three seconds when Timer OFF is set.

Displays 'DF' for three seconds when Fresh,

Swing, Turbo or Silence feature is cancelled.

Displays 'dF' under defrosting operation.

Displays 'cF' when anti-cold air feature is activated under heating mode.

Displays 'SC' during self clean operation (if applicable).

Displays 'FP' under 8°C heating operation (if applicable).

When ECO function(optional) is activated,the

"88" illuminates gradually one by one as E → C → 0 → set temperature → E

In one second interval.



WIFI control display(optional)

Displays when the WIFI control feature is activated.(Not available when the unit does not have this function)

NOTE:

A guide on using the infrared remote is included in this literature package.

7.3 Main Protection

7.3.1 Three minutes delay at restart for compressor

Less than 1 minute delay for the 1st time stand-up and 3 minutes delay for others.

7.3.2 Temperature protection of compressor top

The unit will stop working when the compressor top temp. protector cut off, and will restart after the compressor top temp. protector restart.

7.3.3 Temperature protection of compressor discharge

Compressor discharge temp. $T_5 > 115^{\circ}\text{C}$ for 5s, compressor stops.

7.3.4 Fan speed is out of control

When indoor fan speed keeps too low (300RPM) for certain time, the unit will stop and the LED will display the failure

7.3.5 Inverter module protection

The Inverter module has a protection function about current, voltage and temperature. If these protections happen, the corresponding code will display on indoor unit and the unit will stop working.

7.3.6 Indoor fan delayed open function

When the unit starts up, the louver will be active immediately and the indoor fan will open 7s later.

If the unit runs in heating mode, the indoor fan will be also controlled by anti-cold wind function.

7.3.7 Compressor preheating functions

Preheating permitting condition:

When T_4 (outdoor ambient temperature) $< 3^{\circ}\text{C}$, the preheating function will be activated.

7.3.8 Sensor protection at open circuit and breaking disconnection.

When there's only one temperature sensor in malfunction, the air conditioner will keep working but show the error code, in case of any emergency use.

When there's more than one temperature sensor in malfunction, the air conditioner will stop working

7.3.9 Refrigerant leakage detection

This function is only active in cooling mode. It can better prevent the compressor being damaged by refrigerant leakage or compressor overload.

Open condition:

When compressor is active, the value of the Coil temperature of evaporator T2 has no change or very little change.

7.4 Operation Modes and Functions

7.4.1 Fan mode

- (1) Outdoor fan and compressor stop.
- (2) Temperature setting function is disabled, and no setting temperature is displayed.
- (3) Indoor fan can be set to high/med/low/auto.
- (4) The louver operates same as in cooling mode.
- (5) Auto fan:

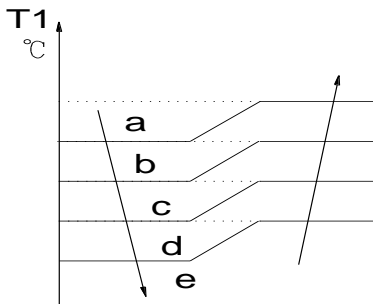

7.4.2 Cooling Mode

7.4.2.1 Compressor running rules

When $T1 - T_s < -2^\circ\text{C}$, the compressor will stop, when $T1 - T_s > -0.5^\circ\text{C}$, the compressor will be activated.

When the AC run in mute mode, the compressor will run with low frequency.

When the current is more than setting value, the current protection function will be activated, and the compressor will stop.

7.4.2.2 Outdoor fan running rules

The outdoor unit will be run at different fan speed according to T4.

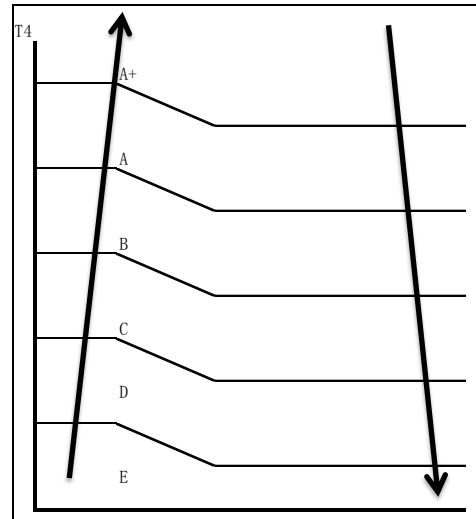

7.4.2.3 Indoor fan running rules

In cooling mode, indoor fan runs all the time and the speed can be selected as high, medium, low and auto.

When the setting temp. is reached, if the compressor stop running, indoor fan motor will run in Minimum speed or setting speed.

The indoor fan is controlled as below:

Setting fan speed	T1-Td °C(°F)	Actual fan speed
H	A	H+ (H+=H+G)
	B	H (=H)
	C	H- (H-=H-G)
M	D	M+ (M+=M+Z)
	E	M (M=M)
	F	M- (M-=M-Z)
L	G	L+ (L+=L+D)
	H	L (L=L)
	I	L- (L-=L-D)

The auto fan acts as below rules:

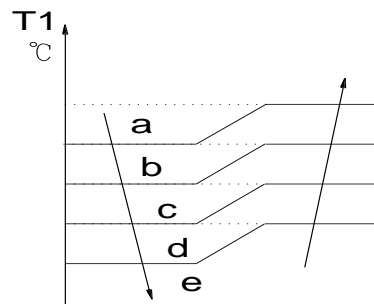

7.4.2.4 Condenser temperature protection

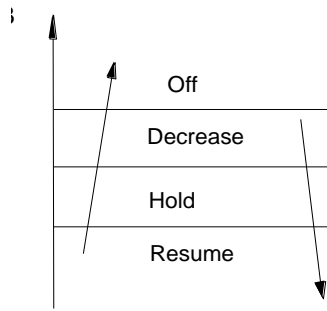

When condenser temperature temp. is more than setting value, the compressor will stop.

7.4.2.5 Evaporator temperature protection

When Evaporator temperature temp. is less than setting value, the compressor will stop.

7.4.3 Heating Mode

7.4.3.1 Compressor running rules

When $T1 - T_s > -\Delta T$, the compressor will stop, when $T1 - T_s < \Delta T - 1.5$ 时, the compressor will be on.

ΔT is the programmed parameter of temperature compensation.

When the AC run in mute mode, the compressor will run with low frequency.

When the current is more than setting value, the current protection function will be activated and the compressor will stop.

7.4.3.2 Outdoor fan running rules

The outdoor unit will be run at different fan speed according to $T4$.

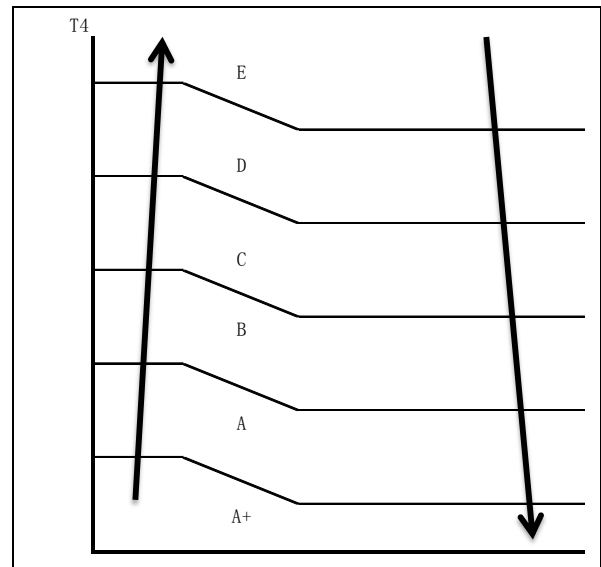

7.4.3.3 Indoor fan running rules

When the compressor is on, the indoor fan can be set to high/med/low/auto/mute.

When indoor unit coil temp. is low, the anti-cold air function will start and indoor fan motor will run at low speed, the speed can't be changed, when the temp. is lower than setting value, the indoor fan motor will stop.

When the indoor temp reaches the setting temp., the compressor will stop, the indoor fan motor will run at the minimum speed or setting speed. (The anti-cold air function is valid).

The indoor fan is controlled as below:

Setting fan speed	$T1 - T_d$ °C	Actual fan speed
H		H- (H=H-G)
		H (=H)
		H+(H+=H+G)
M		M-(M=M-Z)
		M(M=M)
		M+(M+=M+Z)
L		L-(L=L-D)
		L(L=L)
		L+(L+=L+D)

Auto fan action in heating mode:

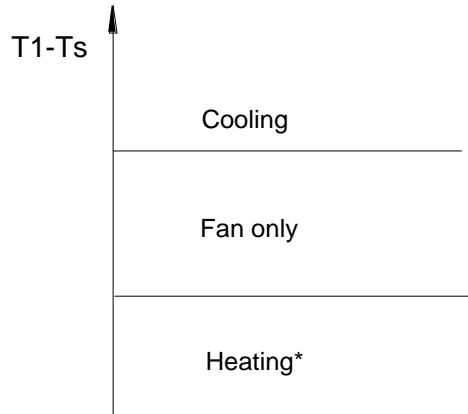
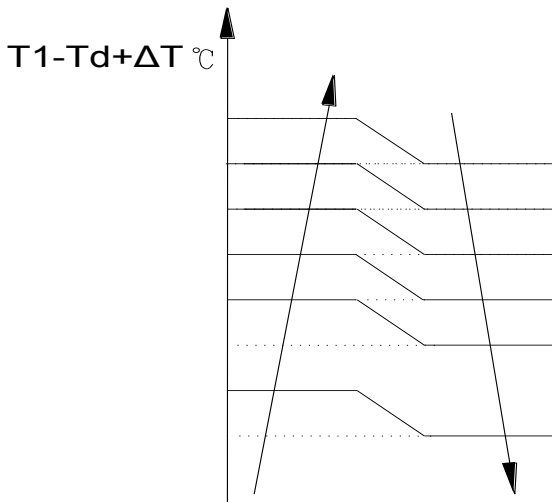

7.4.3.4 Defrosting mode

AC will enter the defrosting mode according to the value of temp. of T3 and the value range of temp. change of T3 and also the compressor running time.

During the defrosting mode, the compressor keep running, indoor and outdoor motor will stop, defrost lamp of the indoor unit will be lighted

“**DF**.” Will be displayed.

7.4.3.5 Evaporator coil temperature protection

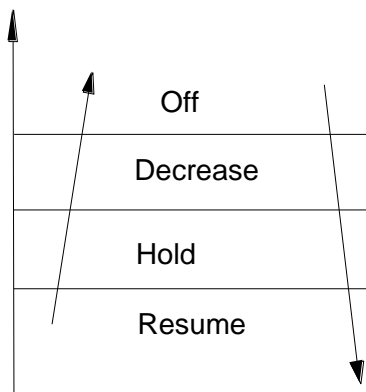

When evaporator temperature temp. is more than the setting protection value, the compressor will stop.

7.4.4 Auto-mode

This mode can be chosen with remote controller and the setting temperature can be changed between 17°C~30°C

In auto mode, the machine will choose cooling, heating or fan-only mode according to ΔT ($\Delta T = T1 - Ts$).

Indoor fan will run at auto fan of the relevant mode.

The louver operates same as in relevant mode. If the machine switches mode between heating and cooling, the compressor will keep stopping for certain time and then choose mode according to T1-Ts.

If the setting temperature is modified, the machine will choose running function again.

7.4.5 Drying mode

Indoor fan speed is fixed at breeze and can't be changed. The louver angle is the same as in cooling mode.

All protections are active and the same as that in cooling mode.

7.4.6 Forced operation function

Forced cooling mode:

The compressor and outdoor fan keep running and the indoor fan runs at low speed. After running for 30 minutes, AC will turn to auto mode with 24°C setting temperature.

Forced auto mode:

The action of forced auto mode is the same as normal auto mode with 24°C setting temperature.

When AC receives signals, such as switch on, switch off, timer on, timer off, mode setting, fan speed setting, sleeping mode setting, follow me setting, it will quit the forced operation.

7.4.7 Auto-Restart function

The indoor unit is equipped with auto-restart function, which is carried out through an auto-restart module. In case of a sudden power failure, the module memorizes the setting conditions before the power failure. The unit will resume the previous operation setting (not including swing function) automatically after 3 minutes when power returns.

If the memorization condition is forced cooling mode, the unit will run in cooling mode for 30 minutes and turn to auto mode as 24°C setting temp.

If AC is off before power off and AC is required to start up now, the compressor will have 1 minute delay when power on. Other conditions, the compressor will have 3 minutes delay when restarts.

7.4.8 8°C Heating(optional)

When the compressor is running, the indoor fan motor will run without anti-cold air function.

When the compressor is off, the indoor fan motor is off .

8. Troubleshooting

Safety

Electricity power is still kept in capacitors even the power supply is shut off. Do not forget to discharge the electricity power in capacitor.

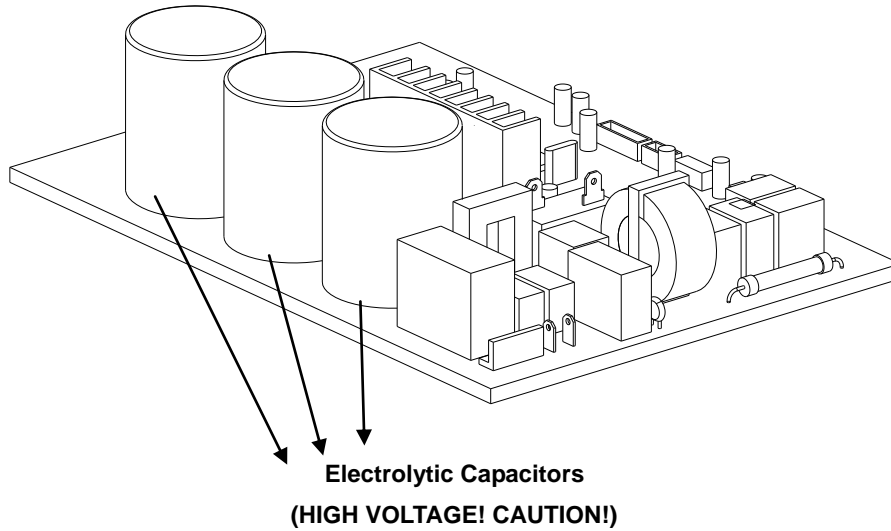

For other models, please connect discharge resistance (approx.100Ω 40W) or soldering iron (plug) between +, - terminals of the electrolytic capacitor on the contrary side of the outdoor PCB.

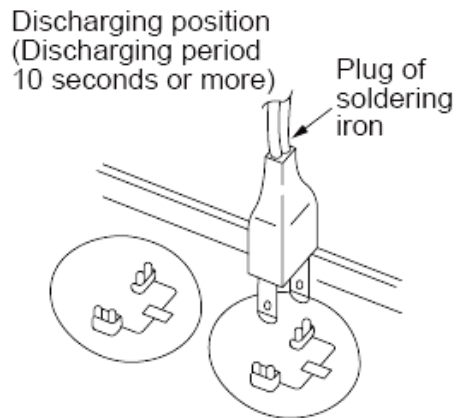

Note: The picture above is only for reference. The plug of your side may be different.

8.1 Indoor Unit Error Display

Operation lamp	Timer lamp	Display	LED STATUS
☆ 1 time	X	E0	Indoor unit EEPROM parameter error
☆ 2 times	X	E1	Indoor / outdoor units communication error
☆ 4 times	X	E3	Indoor fan speed has been out of control
☆ 5 times	X	E4	Indoor room temperature sensor T1 open circuit or short circuit
☆ 6 times	X	E5	Evaporator coil temperature sensor T2 open circuit or short circuit
☆ 7 times	X	EC	Refrigerant leakage detection
☆ 2 times	O	F1	Outdoor ambient temperature sensor T4 open circuit or short circuit
☆ 3 times	O	F2	Condenser coil temperature sensor T3 open circuit or short circuit
☆ 4 times	O	F3	Compressor discharge temperature sensor T5 open circuit or short circuit
☆ 5 times	O	F4	Outdoor unit EEPROM parameter error
☆ 6 times	O	F5	Outdoor fan speed has been out of control
☆ 1 times	☆	P0	IPM malfunction or IGBT over-strong current protection
☆ 2 times	☆	P1	Over voltage or over low voltage protection
☆ 3 times	☆	P2	High temperature protection of compressor top diagnosis and solution
☆ 5 times	☆	P4	Inverter compressor drive error

O (light)

X (off)

☆ (flash)

8.2 Trouble shooting

8.2.1 EEPROM parameter error diagnosis and solution(E0/F4)

Error Code	E0/F4
Malfunction decision conditions	Indoor or outdoor PCB main chip does not receive feedback from EEPROM chip.
Supposed causes	<ul style="list-style-type: none">● Installation mistake● PCB faulty

Trouble shooting:

Power off, then restart the unit 2 minutes later.

Yes

Replace the indoor/outdoor main PCB.

EEPROM: a read-only memory whose contents can be erased and reprogrammed using a pulsed voltage. For the location of EEPROM chip, please refer to the below photos.

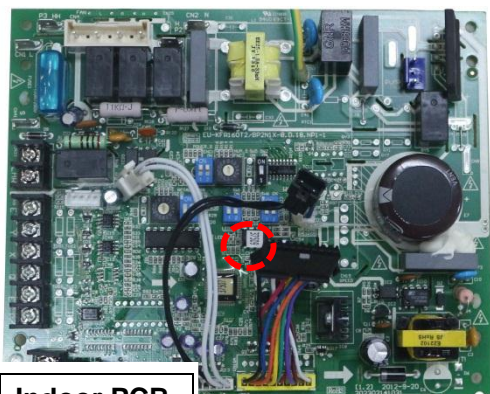

Indoor PCB

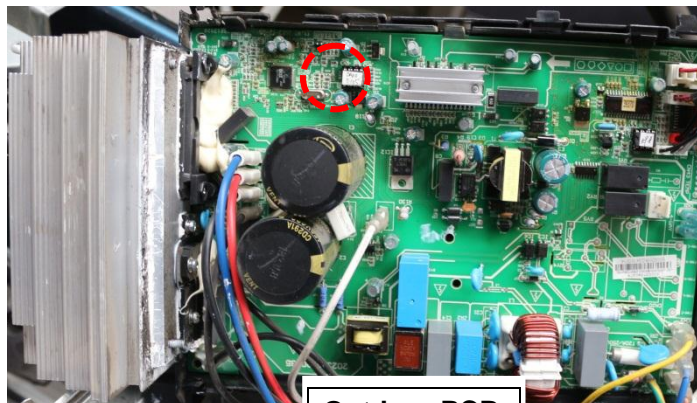

Outdoor PCB

Note: The two photos above are only for reference, it's may be not same totally with the ones on your side.

8.2.2 Indoor / outdoor unit's communication diagnosis and solution(E1)

Error Code	E1
Malfunction decision conditions	Indoor unit does not receive the feedback from outdoor unit during 110 seconds and this condition happens four times continuously.
Supposed causes	<ul style="list-style-type: none"> ● Wiring mistake ● Indoor or outdoor PCB faulty

Trouble shooting:

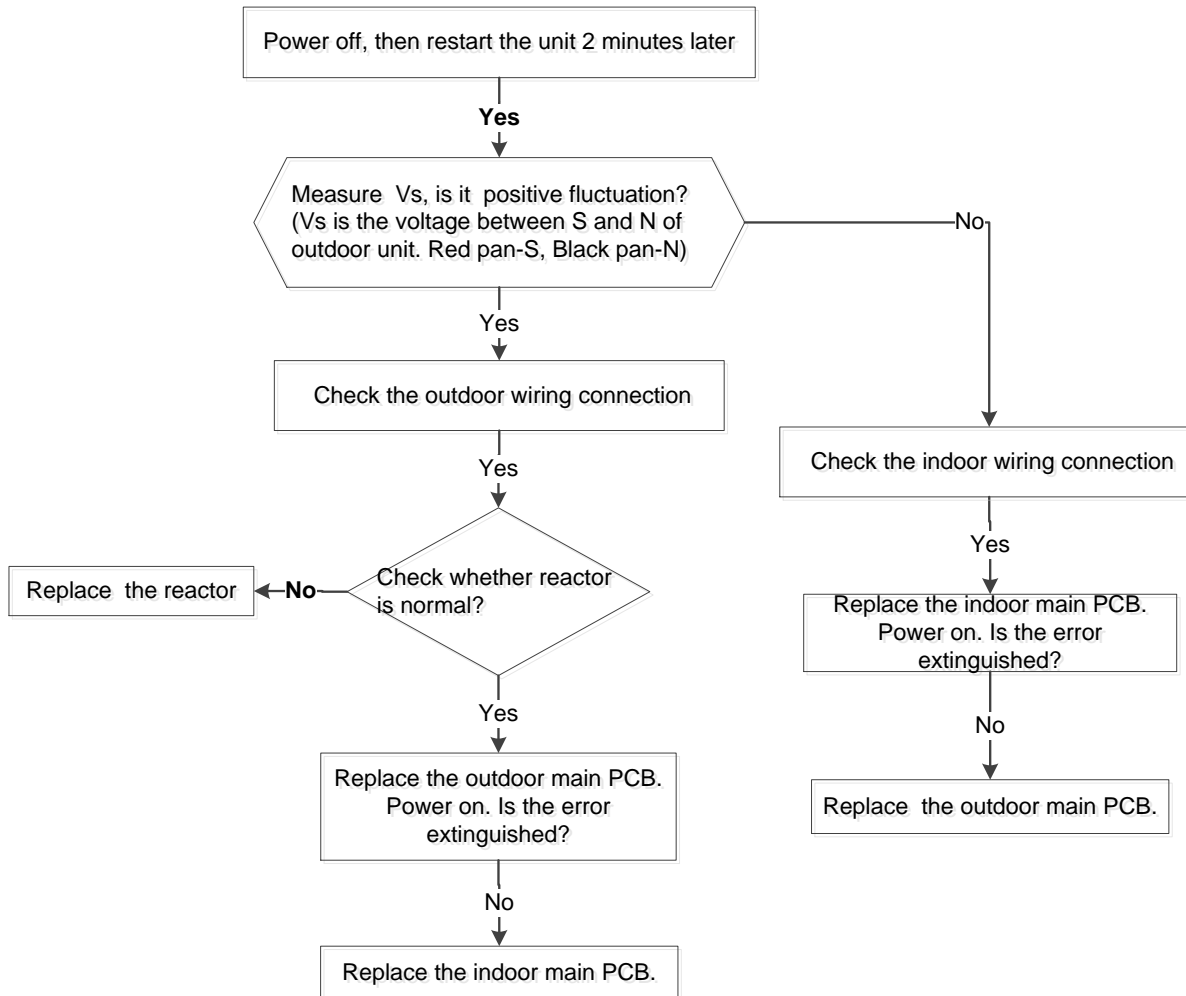

8.2.4 Fan speed has been out of control diagnosis and solution(E3)

Error Code	E3/F5
Malfunction decision conditions	When indoor fan speed keeps too low (300RPM) for certain time, the unit will stop and the LED will display the failure.
Supposed causes	<ul style="list-style-type: none"> ● Wiring mistake ● Fan ass'y faulty ● Fan motor faulty ● PCB faulty

Trouble shooting:

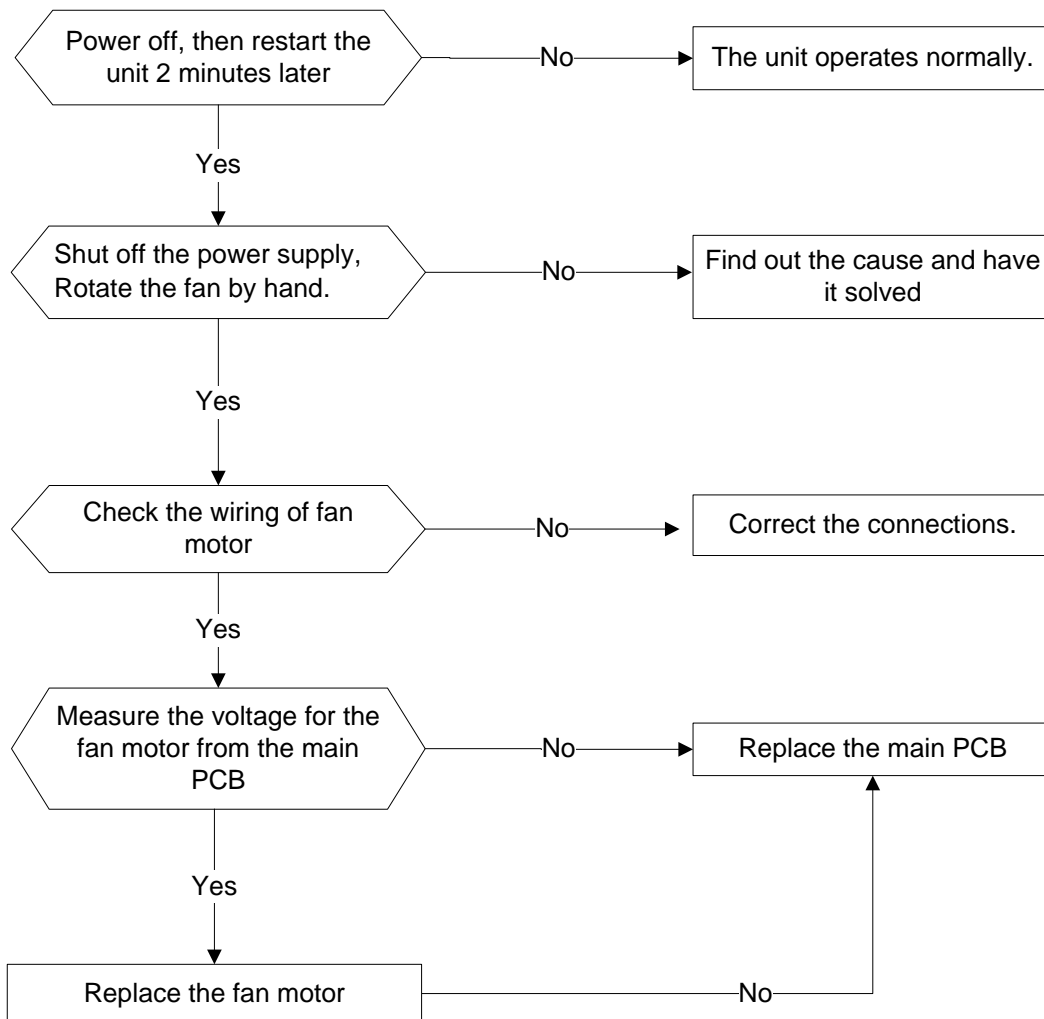

Index1:

1:Indoor or Outdoor DC Fan Motor(control chip is in fan motor)

Power on and when the unit is in standby, measure the voltage of pin1-pin3, pin4-pin3 in fan motor connector. If the value of the voltage is not in the range showing in below table, the PCB must has problems and need to be replaced.

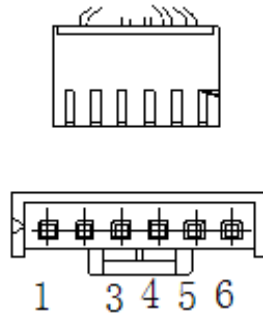

DC motor voltage input and output

NO.	Color	Signal	Voltage
1	Red	Vs/Vm	280V~380V
2	---	---	---
3	Black	GND	0V
4	White	Vcc	14-17.5V
5	Yellow	Vsp	0~5.6V
6	Blue	FG	14-17.5V

2. Outdoor DC Fan Motor (control chip is in outdoor PCB)

Power on ,and check if the fan can run normally, if the fan can run normally, the PCB must has problems and need to be replaced, If the fan can't run normally, measure the resistance of each two pins. If the resistance is not equal to each other, the fan motor must have problems and need to be replaced, otherwise the PCB must has problems and need to be replaced.

3. Indoor AC Fan Motor

Power on and set the unit running in fan mode at high fan speed. After running for 15 seconds, measure the voltage of pin1 and pin2. If the value of the voltage is less than 100V(208~240V power supply)or 50V(115V power supply), the PCB must has problems and need to be replaced.

8.2.4 Refrigerant Leakage Detection diagnosis and solution(EC)

Error Code	EC
Malfunction decision conditions	<p>Define the evaporator coil temp.T2 of the compressor just starts running as Tcool.</p> <p>In the beginning 5 minutes after the compressor starts up, if $T2 < T_{cool} - 2^{\circ}\text{C}$ does not keep continuous 4 seconds and this situation happens 3 times, the display area will show “EC” and AC will turn off.</p>
Supposed causes	<ul style="list-style-type: none"> ● T2 sensor faulty ● Indoor PCB faulty ● System problems, such as leakage or blocking.

Trouble shooting:

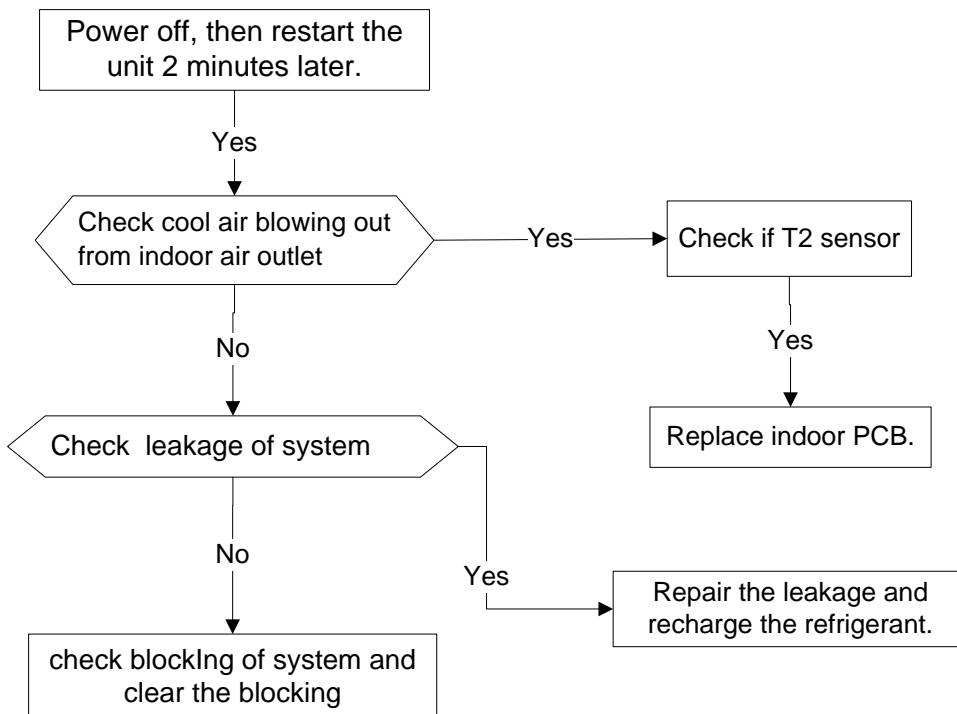

8.2.5 Open circuit or short circuit of temperature sensor diagnosis and solution(E5)

Error Code	E4/E5/F1/F2/F3
Malfunction decision conditions	If the sampling voltage is lower than 0.06V or higher than 4.94V, the LED will display the failure.
Supposed causes	<ul style="list-style-type: none">• Wiring mistake• Sensor faulty

Trouble shooting:

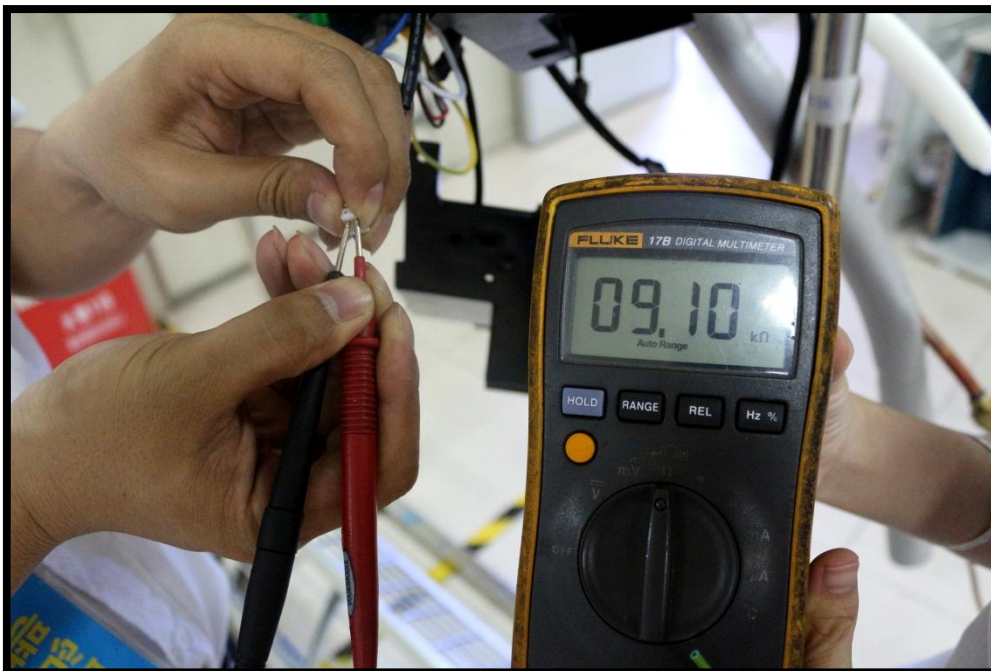
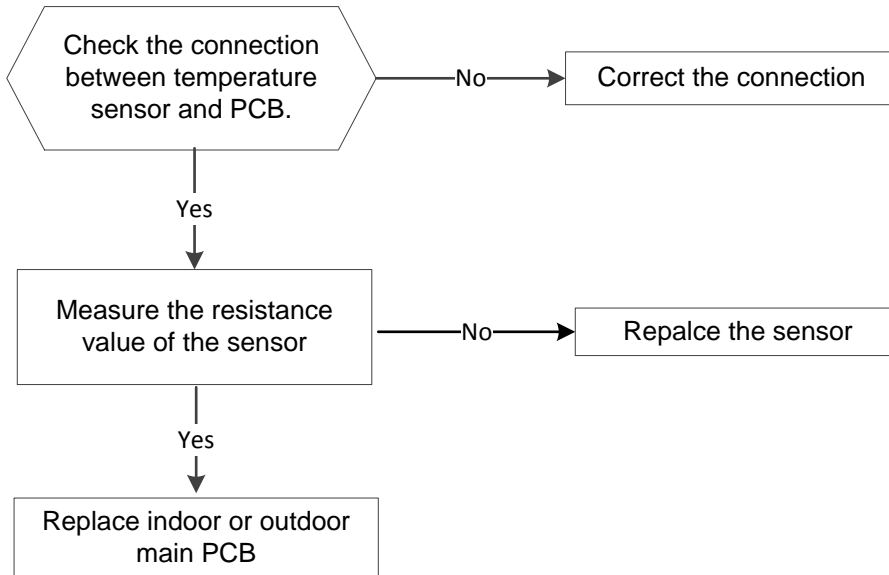

8.2.6 IPM malfunction or IGBT over-strong current protection diagnosis and solution(P0)

Error Code	P0
Malfunction decision conditions	When the voltage signal that IPM send to compressor drive chip is abnormal, the display LED will show “P0” and AC will turn off.
Supposed causes	<ul style="list-style-type: none"> ● Wiring mistake ● IPM malfunction ● Outdoor fan ass’y faulty ● Compressor malfunction ● Outdoor PCB faulty

Trouble shooting:

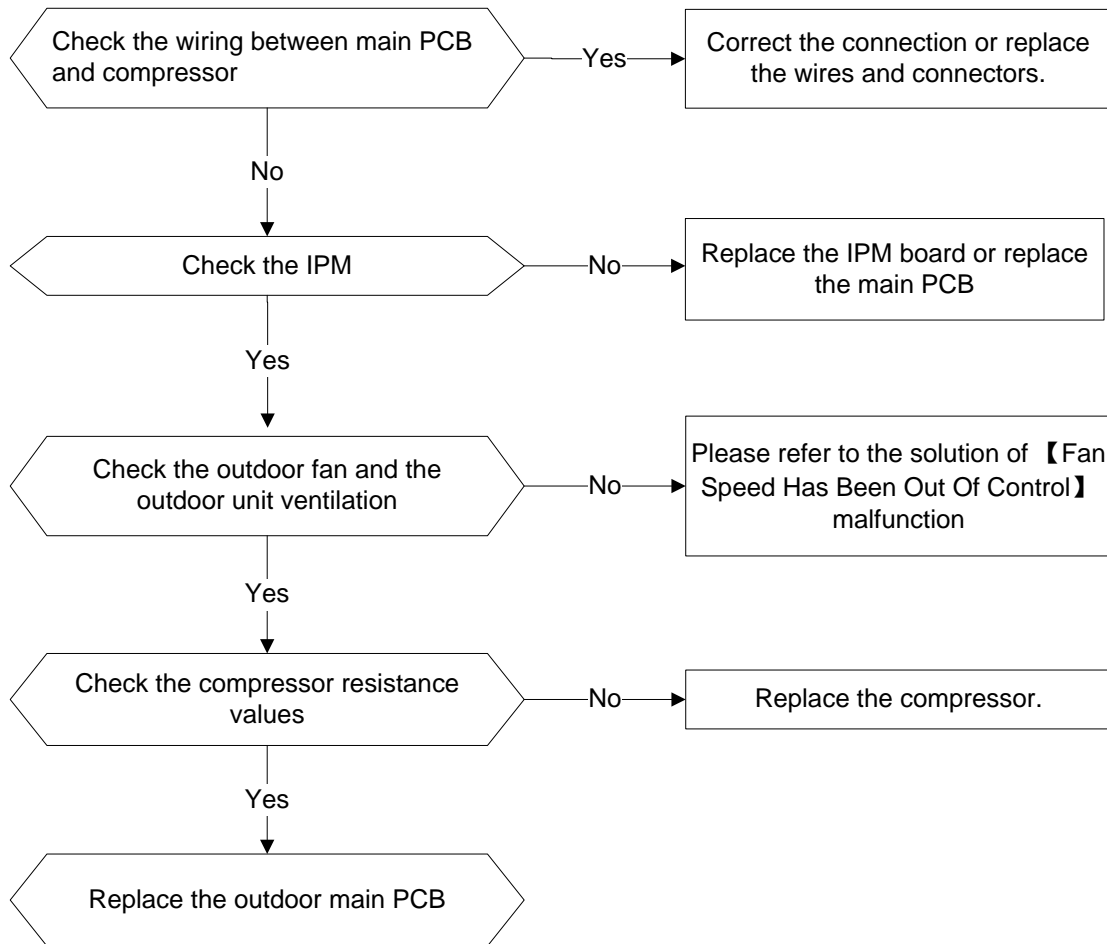

➤ IPM continuity check

Turn off the power, let the large capacity electrolytic capacitors discharge completely, and dismount the IPM. Use a digital tester to measure the resistance between P and UVWN; UVW and N.

Digital tester		Normal resistance value	Digital tester		Normal resistance value
(+)Red	(-)Black		(+)Red	(-)Black	
P	N	∞ (Several MΩ)	U	N	∞ (Several MΩ)
	U		V		
	V		W		
	W		(+)Red		

8.2.7 Over voltage or too low voltage protection diagnosis and solution(P1)

Error Code	P1
Malfunction decision conditions	An abnormal voltage rise or drop is detected by checking the specified voltage detection circuit.
Supposed causes	<ul style="list-style-type: none"> ● Power supply problems. ● System leakage or block ● PCB faulty

Trouble shooting:

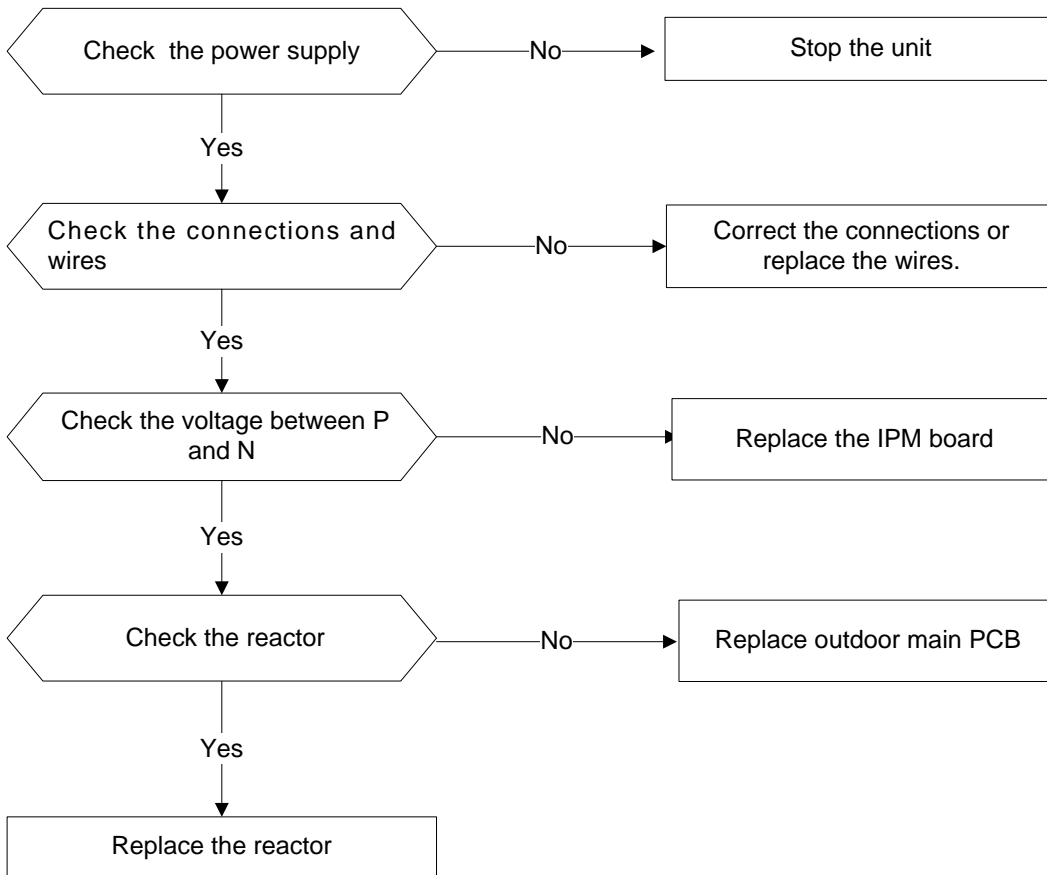

8.2.8 High temperature protection of compressor top diagnosis and solution(P2)

Error Code	P2
Malfunction decision conditions	If the sampling voltage is not 5V, the LED will display the failure.
Supposed causes	<ul style="list-style-type: none"> ● Power supply problems. ● System leakage or block ● PCB faulty

Trouble shooting:

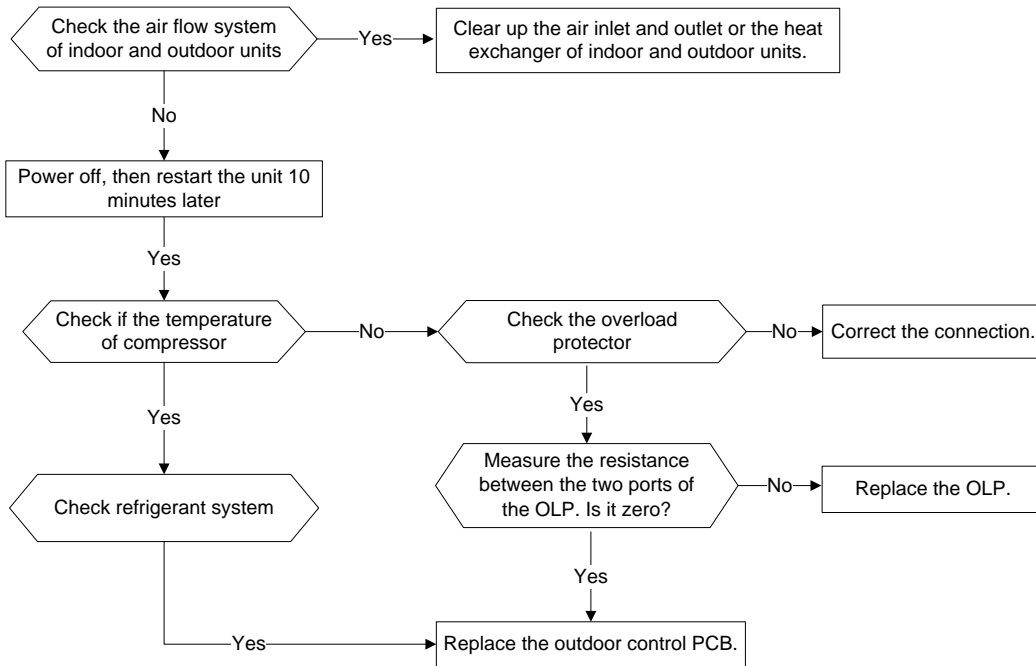

8.2.9 Inverter compressor drive error diagnosis and solution(P4)

Error Code	P4
Malfunction decision conditions	An abnormal inverter compressor drive is detected by a special detection circuit, including communication signal detection, voltage detection, compressor rotation speed signal detection and so on.
Supposed causes	<ul style="list-style-type: none"> ● Wiring mistake ● IPM malfunction ● Outdoor fan ass'y faulty ● Compressor malfunction ● Outdoor PCB faulty

Trouble shooting:

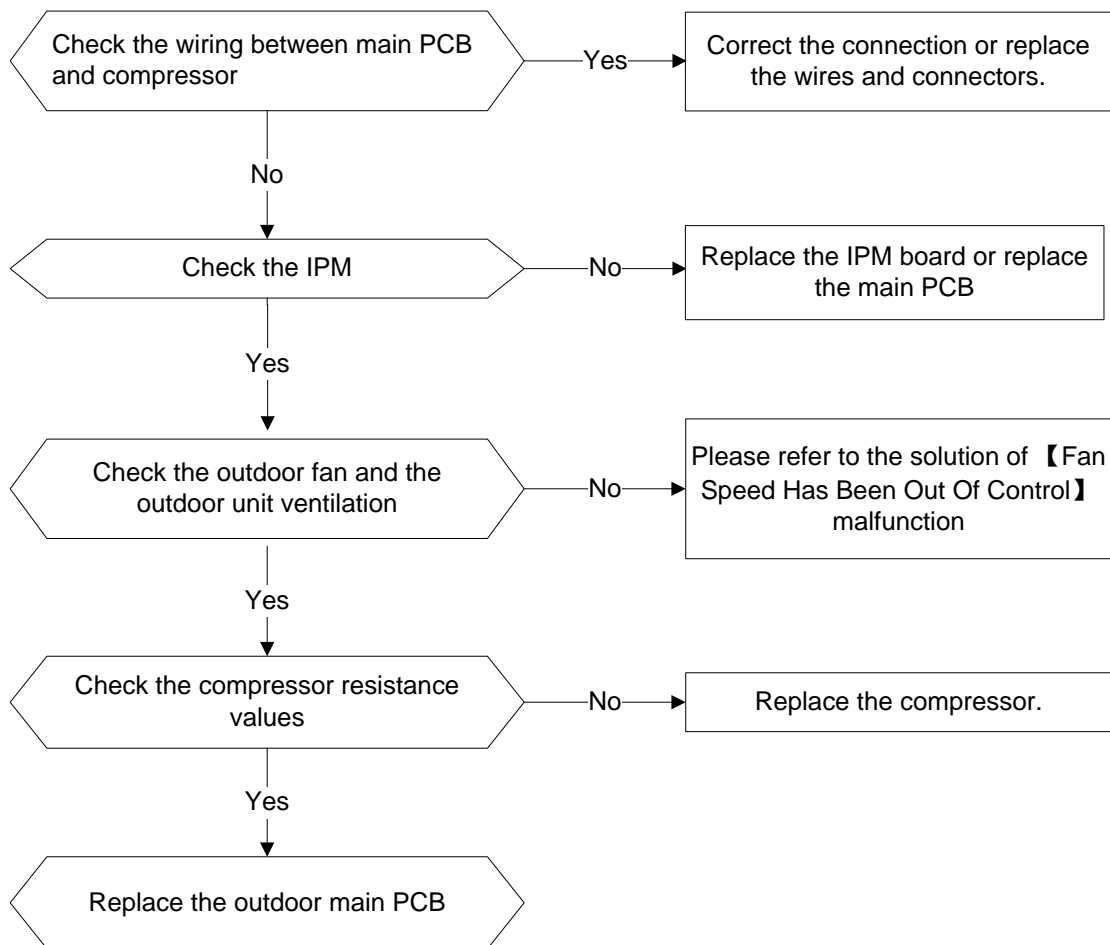

Main parts check

1. Temperature sensor checking

Disconnect the temperature sensor from PCB, measure the resistance value with a tester.

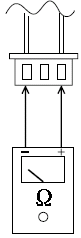

Tester

Temperature Sensors.

Room temp.(T1) sensor,

Indoor coil temp.(T2) sensor,

Outdoor coil temp.(T3) sensor,

Outdoor ambient temp.(T4) sensor,

Compressor discharge temp.(T5) sensor.

Measure the resistance value of each winding by using the multi-meter.

Appendix 1 Temperature Sensor Resistance Value Table (°C--K)

°C	K Ohm	°C	K Ohm	°C	K Ohm	°C	K Ohm
-20	115.266	20	12.6431	60	2.35774	100	0.62973
-19	108.146	21	12.0561	61	2.27249	101	0.61148
-18	101.517	22	11.5000	62	2.19073	102	0.59386
-17	96.3423	23	10.9731	63	2.11241	103	0.57683
-16	89.5865	24	10.4736	64	2.03732	104	0.56038
-15	84.2190	25	10.0000	65	1.96532	105	0.54448
-14	79.3110	26	9.55074	66	1.89627	106	0.52912
-13	74.5360	27	9.12445	67	1.83003	107	0.51426
-12	70.1698	28	8.71983	68	1.76647	108	0.49989
-11	66.0898	29	8.33566	69	1.70547	109	0.48600
-10	62.2756	30	7.97078	70	1.64691	110	0.47256
-9	58.7079	31	7.62411	71	1.59068	111	0.45957
-8	56.3694	32	7.29464	72	1.53668	112	0.44699
-7	52.2438	33	6.98142	73	1.48481	113	0.43482
-6	49.3161	34	6.68355	74	1.43498	114	0.42304
-5	46.5725	35	6.40021	75	1.38703	115	0.41164
-4	44.0000	36	6.13059	76	1.34105	116	0.40060
-3	41.5878	37	5.87359	77	1.29078	117	0.38991
-2	39.8239	38	5.62961	78	1.25423	118	0.37956
-1	37.1988	39	5.39689	79	1.21330	119	0.36954
0	35.2024	40	5.17519	80	1.17393	120	0.35982
1	33.3269	41	4.96392	81	1.13604	121	0.35042
2	31.5635	42	4.76253	82	1.09958	122	0.3413
3	29.9058	43	4.57050	83	1.06448	123	0.33246
4	28.3459	44	4.38736	84	1.03069	124	0.32390
5	26.8778	45	4.21263	85	0.99815	125	0.31559
6	25.4954	46	4.04589	86	0.96681	126	0.30754
7	24.1932	47	3.88673	87	0.93662	127	0.29974
8	22.5662	48	3.73476	88	0.90753	128	0.29216
9	21.8094	49	3.58962	89	0.87950	129	0.28482
10	20.7184	50	3.45097	90	0.85248	130	0.27770
11	19.6891	51	3.31847	91	0.82643	131	0.27078
12	18.7177	52	3.19183	92	0.80132	132	0.26408
13	17.8005	53	3.07075	93	0.77709	133	0.25757
14	16.9341	54	2.95896	94	0.75373	134	0.25125
15	16.1156	55	2.84421	95	0.73119	135	0.24512
16	15.3418	56	2.73823	96	0.70944	136	0.23916
17	14.6181	57	2.63682	97	0.68844	137	0.23338
18	13.9180	58	2.53973	98	0.66818	138	0.22776
19	13.2631	59	2.44677	99	0.64862	139	0.22231

2.Compressor checking

Measure the resistance value of each winding by using the tester.

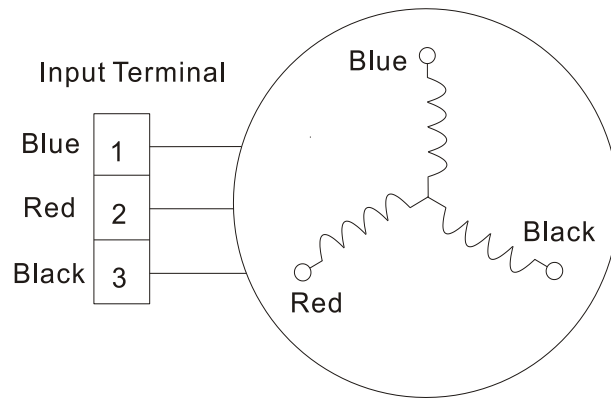

Position	Resistance Value		
	ASN98D22UFZ	ASM135D23UFZ	DA200S2C-10MT
Blue - Red	1.57Ω (20°C/68°F)	1.75Ω (20°C/68°F)	0.51Ω (20°C/68°F)
Blue - Black			
Red - Blue			