

KD85

INSTRUCTION MANUAL

IMPORTANT! Read these instructions before you use your new KD85 Key Machine.

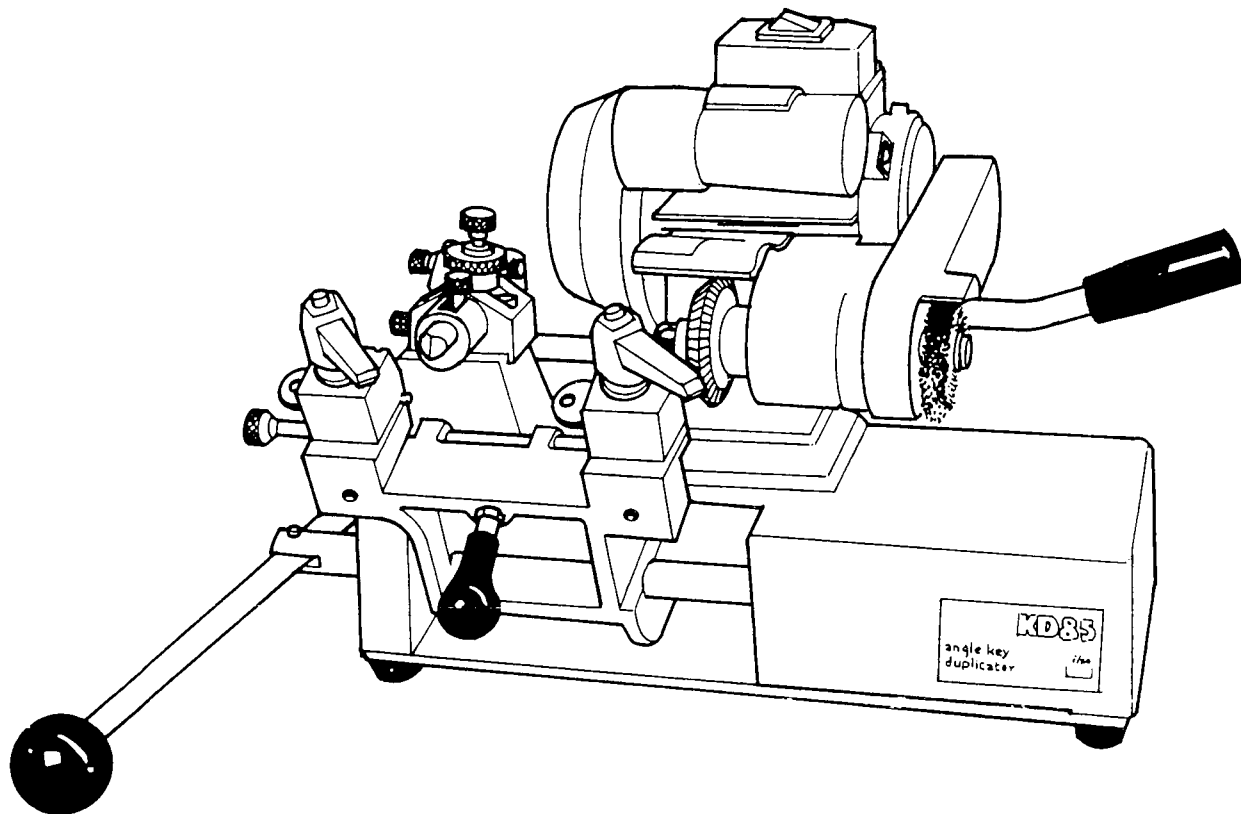

ILCO UNICAN

USA: 400 Jeffreys Rd., P. O. Box 2627, Rocky Mount, NC 27802-2627 • Tel: (919) 446-3321 • FAX: (919) 446-4702
EXPORT: 7301 Decarie Blvd., Montreal, Que. H49 2G7 • Tel: (514) 735-5411 • FAX: (514) 273-3521



This manual is registered and applies specifically to the machine which carries this serial number. It properly identifies your model and assures you will receive correct parts, if and when you require replacement parts. Retain this manual in a safe place. It's the only one of its kind. If ownership of this machine is trans-

ferred, this service manual should accompany the machine.

When seeking service information about this machine, refer to the Model No. (which is KD85), your registration number (see below) and the part number desired (see pages 4 to 9). Note that some parts are

CONTENTS

interchangeable with other ILCO ORION models.	
Warranty.....	2
Introduction to the KD85.....	3
Operating Parts (Illustrated)	4
Operating Parts Identification (Names and Part Numbers).....	5
Exploded View Parts List (Names and Part Numbers)	6-7
Exploded View of Parts	8-9
The Cutting Operation, Assembly Instructions	10
The Cutting Operation, Proper Key Cutting Techniques	11
Adjusting for Proper Depth of Cut	12
Adjusting for Proper Lateral Distance (Spacing)	13
How to Duplicate Keys, Standard Cut, Angle Cut	14-15
Cutting Angle Keys by Code.....	15
Replacements (Cutter and Brush)	16

ONE YEAR LIMITED WARRANTY

ILCO UNICAN warrants to the original buyer of any new model KD85 machine that it will repair or replace, at its option, any part of any machine which proves, to the reasonable satisfaction of ILCO UNICAN, to have defects arising from the faulty manufacture of the machine or from defective material or components, during a period of one (1) year from the date of shipment of the machine by ILCO UNICAN, provided that the machine is returned by prepaid transport to ILCO UNICAN or to its authorized representative before the expiry of the warranty period together with a detailed description of the alleged defect(s). ILCO UNICAN may, at its discretion, elect to refund the purchase price allocable to the part affected, or to issue a credit if the price therefore remains unpaid.

ILCO UNICAN sells precision-made machines. The buyer assumes all risks, and ILCO UNICAN shall not be liable for any reason, if the machine has been subjected to improper installation, improper use, improper or inadequate maintenance, negligence, if any unauthorized modification or alteration is made to the machine, or in case of accident. For greater certainty, any machine not operated in accordance with ILCO UNICAN's printed instructions or operated beyond its rated capacity shall not be covered by this or any other warranty.

Any and all warranties made by ILCO UNICAN on any machine, product, or component thereof shall be effective only if and for so long as the buyer complies with all payment obligations pursuant to the buyer's accepted and acknowledged order. Failure to meet such payment obligations shall void all warranties and not extend the period of time for which such machine, product or component thereof is warranted irrespective of whether or not payment is eventually made.

These warranties are in lieu of and not in addition to any other warranty of condition, expressed or implied, including without limitation merchantability, fitness for a particular purpose or latent defects. The buyer releases ILCO UNICAN from any liability for any reason other than a breach of its warranties hereunder.

The liability of ILCO UNICAN shall in no case, including negligence, exceed the purchase price of the defective machine, nor shall ILCO UNICAN be liable for any personal injuries, property damage or consequential damages.

Use only genuine ILCO UNICAN replacement parts on this machine!

Registration and Serial number is _____

The KD85 At A Glance

Congratulations! You have just purchased the ILCO ORION KD85 angle key machine. This unique product is actually three key machines in one: first, the KD85 is specifically engineered to duplicate angle cut keys, such as Medeco® and Emhart®. Second, the KD85 can originate an angle cut key from code information. Third, the KD85 can cut a standard single or double bitted duplicate key from a pattern key.

This unique lever-operated key machine has three factory pre-set cutter angle positions: left tilt, center,

and right tilt. When the locksmith is not cutting special angle keys, the tilting feature can be blocked. After the tilting feature has been neutralized, the KD85 can be used to duplicate most standard single and double bitted automotive and residential type keys.

The KD85 also features positive grip vise jaws as well as a micrometer-style knob for accurate depth adjustments. A convenient side mounted deburring brush is also featured, as well as a sturdy belt guard, which covers the belts and pulleys.

UNPACKING

When unpacking the KD85, you'll notice the protective cushioning material and the abundance of oil that has been applied to prevent rust and corrosion. Before using the machine, wipe off the excess oil and grease. Only the moving parts have to be lubricated.

Place the machine on a sturdy workbench or counter. Make sure the machine power switch is in the off position (depressed so its O side is in the housing). Then, plug the power cord into a 110 Volt AC receptacle,

preferably one with a surge protector. Because of the heavy duty construction, it is not necessary to bolt down the KD85.

Refer to the drawing on page 4 to identify the operating parts. Note that three handles have to be installed on the machine; instructions for installing these handles are given on page 10. Do not attempt to operate this machine without the handles being securely installed.

SAFETY

The KD85 has been engineered to originate and to duplicate cylinder keys. It is not intended or designed for any other purpose. The machine operator assumes all liability when using this machine in a manner inconsistent with its stated design purpose.

ILCO UNICAN strongly recommends the use of protective eye glasses or goggles when operating this machine, or when in the vicinity of the machine while it is being operated. Protective eye wear prevents injuries!

Note that this machine does not turn off automatically when the carriage is released.

When the key machine is operating, be careful not to butt the vise jaw or carriage against the cutting wheel as this will cause damage to the cutter, the vise jaw, and the carriage. It also will dull the cutter quickly.

The key deburring brush is metal and may cause injury to fingers and/or hands. When deburring, hold the key firmly by its head and rotate the key under the brush.

CAUTION! DO NOT DESTROY OR DISCARD THIS VALUABLE SHIPPING CARTON. STORE IT CAREFULLY IN A SAFE PLACE. IN THE EVENT OF A PROBLEM WITH YOUR MACHINE, IT MUST BE RETURNED TO OUR SERVICE FACILITY IN ITS ORIGINAL PROTECTIVE CARTON.

OPERATING PARTS

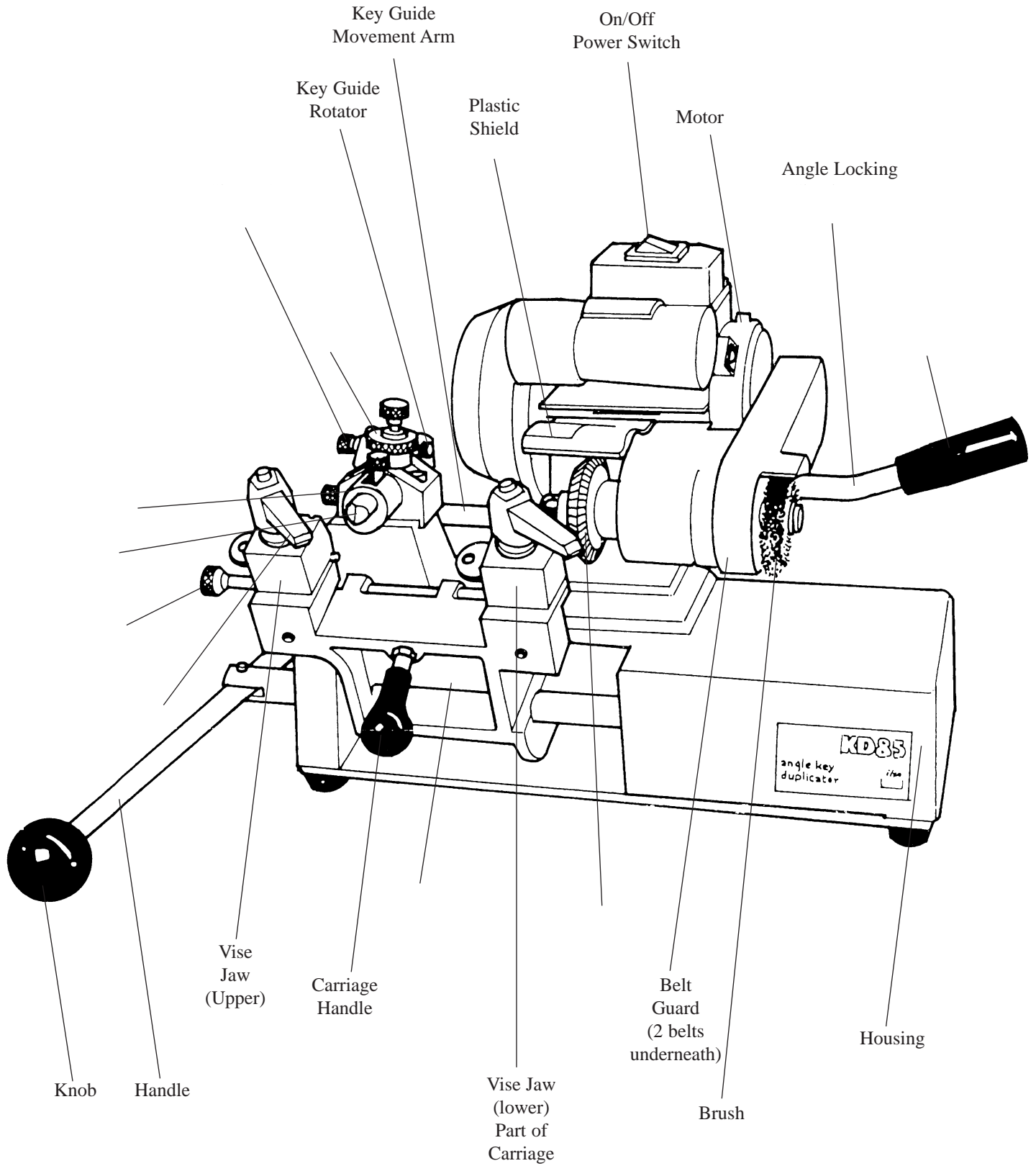

OPERATING PARTS IDENTIFICATION

Refer to page 4.

Part No.	Identification
KD85-1	Housing
KD85-9	Motor
KD85-15	On/Off Switch, Rocker Type
KD85-23	Carriage
KD85-31	Handle
KD85-32	Knob
KD85-53	Upper Vise Jaw (2)
KD85-58	Clamp Assembly (2)
KD85-61	Clamp Screw (Block)
KD85-62	Carriage Handle
KD85-68	Knob, Setting Gauge
KD85-89	Key Guide
KD85-102	Brush, 2" diameter
KD85-104	Plastic Shield
KD85-200	Belt Guard
KD85-207	Angle Locking Clutch Lever
KD85-208	Angle Locking Clutch Lever Handle
KD85-220	Key Guide Movement Arm
KD85-221	Key Guide Housing
KD85-227	Key Guide Rotator
KD85-D	Depth Knob Cam
CU85	Cutter

EXPLODED VIEW PARTS LIST

Refer to pages 8 and 9 for illustrations.

Part No.	Description	Part No.	Description
KD85-1	Housing	KD85-97	Cutter Washer
KD85-2	Case (Housing Base Plate)	KD85-98	Bearing
KD85-5	Motor Shelf	KD85-99	Bearing Spacer, External
KD85-7	Motor Pulley	KD85-99IN	Bearing Spacer, Internal
KD85-8	Reflex Belt Y17 (6mm x 500mm)	KD85-100	Pulley, Cutter Spindle
KD85-9	Motor (110v 60 Hz)	KD85-101	Washer, Brush Spacer
KD85-15	On/Off Switch, Rocker Type	KD85-102	Brush, 2" diameter
KD85-23	Carriage	KD85-103	Brush, Shoulder Screw
KD85-24	Carriage Shaft	KD85-104	Plastic Shield
KD85-31	Handle	KD85-107	Foot
KD85-32	Knob	KD85-111	Service Bar
KD85-52	Vise Jaw Spring (4)	KD85-137	ILCO ORION Label
KD85-53	Upper Vise Jaw (2)	KD85-151	Oiling Ball
KD85-55	Vise Jaw Post (2)	KD85-200	Belt Guard (Metal)
KD85-58	Clamp Assembly (2)	KD85-201	Belt Guard Spacer (Short)
KD85-61	Clamp Screw (Block)	KD85-202	Belt Guard Spacer (Long)
KD85-62	Carriage Handle	KD85-203	Angle Setting Plate
KD85-63	Extension Arm (Sleeve)	KD85-204	Angle Locking Clutch Pin (4mm x 40mm)
KD85-64	Finger, Setting Gauge	KD85-205	Angle Locking Clutch
KD85-66	Spring, Setting Gauge	KD85-206	Angle Locking Clutch Spring
KD85-67	Shaft, Setting Gauge	KD85-207	Angle Locking Clutch Lever
KD85-68	Knob, Setting Gauge	KD85-208	Angle Locking Clutch Lever Handle
KD85-69	Sleeve, Setting Gauge	KD85-209	Angle Setting Label
KD85-89	Key Guide	KD85-211	Cutter Spindle Housing
KD85-93	Key Guide Adjusting Screw	KD85-212	Cutter Spindle Washer (238 x 15 x 25mm)
KD85-94	Depth Knob Cam Pin	KD85-213	Cutter Spindle Housing Pin (4mm x 10mm)
KD85-95	Cutter Spindle	KD85-214	Cutter Spacer (3/8" x 16mm x 9.5mm)
KD85-96	Cutter (Acorn) Nut, Left Hand	KD85-215	Cutter Spindle Housing Washer (Brass)

EXPLODED VIEW PARTS LIST

Refer to pages 8 and 9 for illustrations.

Part No.	Description	Part No.	Description
KD85-216	Cutter Spindle Housing Anchor Washer	KD85-229	Detent Release Shaft
KD85-217	Cutter Spindle Housing Anchor Nut	KD85-230	Key Guide Rotator Control Plate
KD85-220	Key Guide Movement Arm	KD85-231	Handle - Carriage Connecting Pin
KD85-221	Key Guide Housing	KD85-232	Handle "O" Ring
KD85-222	Key Guide Barrel	KD85-233	Handle Link
KD85-223	Key Guide Adjusting Screw Housing	KD85-234	Handle Support Pin
KD85-224	Depth Knob Cam Washer	KD85-235	Handle SupportCU85 Cutter
KD85-225	Depth Knob Cam Tension Spring	KD85-D	Depth Knob Cam
KD85-226	Key Guide Barrel Retaining Ring	KD85-DLS	Depth Knob Cam Locking Screw
KD85-227	Key Guide Rotator	KD85-IM	Instruction Manual
KD85-228	Key Guide Rotator Space Plate	KD85-SMG	Spacing Plate (hgt - 5.99mm)
		KD85-SMP	Spacing Plate (hgt.- 6.75mm)

OPERATING ACCESSORIES



Service Bar

Used to adjust spacing and depth. Also serves as stop for shoulderless keys.



Service Pins

Used as shims to raise narrow blade keys above surface of vise jaw.



Metric Allen Wrench

Various size wrenches are used to loosen and retighten set screws on the machine.



Metric Wrench

Used to loosen and retighten cutter nut and belt tension adjustment nut.



Cutter Spindle Bar

Used to hold cutter spindle rigid while removing cutter nut.

EXPLODED VIEW

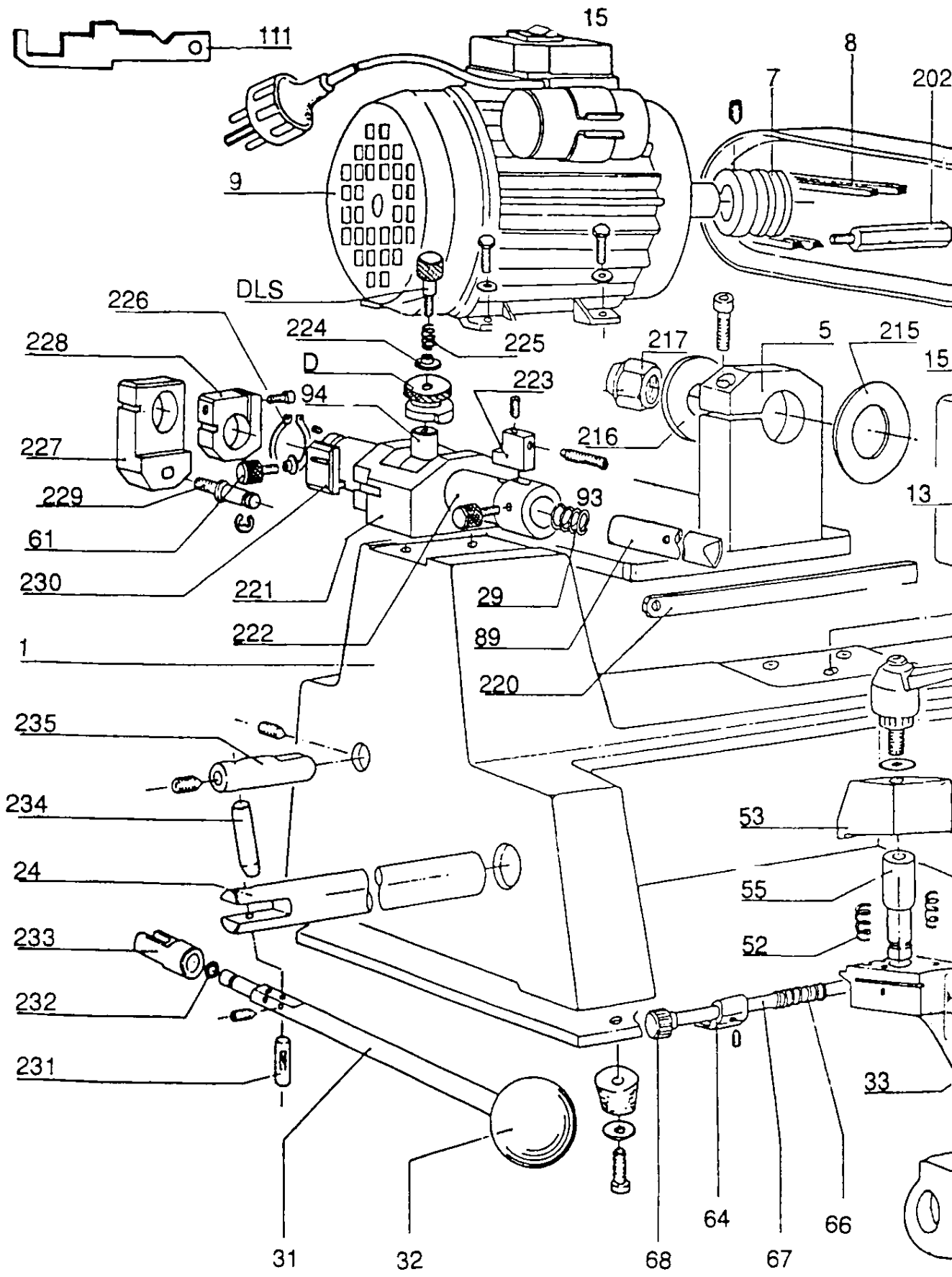

EXPLODED VIEW

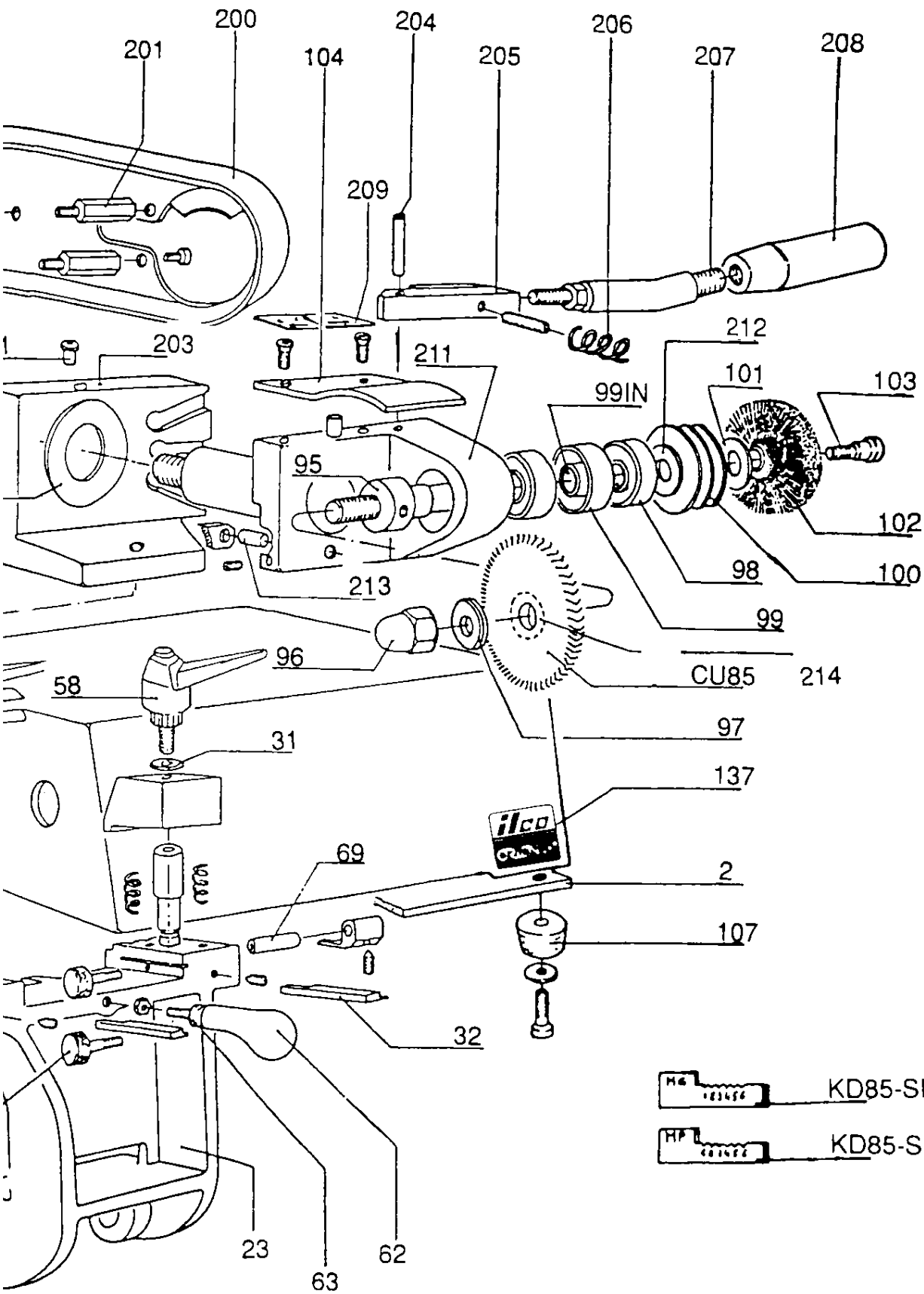

KG KD85-SMG

HP KD85-SMP

THE CUTTING OPERATION

ASSEMBLY INSTRUCTIONS

The KD85 key machine comes completely assembled except for three handles. These handles can be attached in just a few moments by following these simple instructions. Note that all set screws are metric.

ble through the threaded retaining hole (See Figure 1).

3. Insert, thread and tighten the retaining screw to secure the connecting pin.

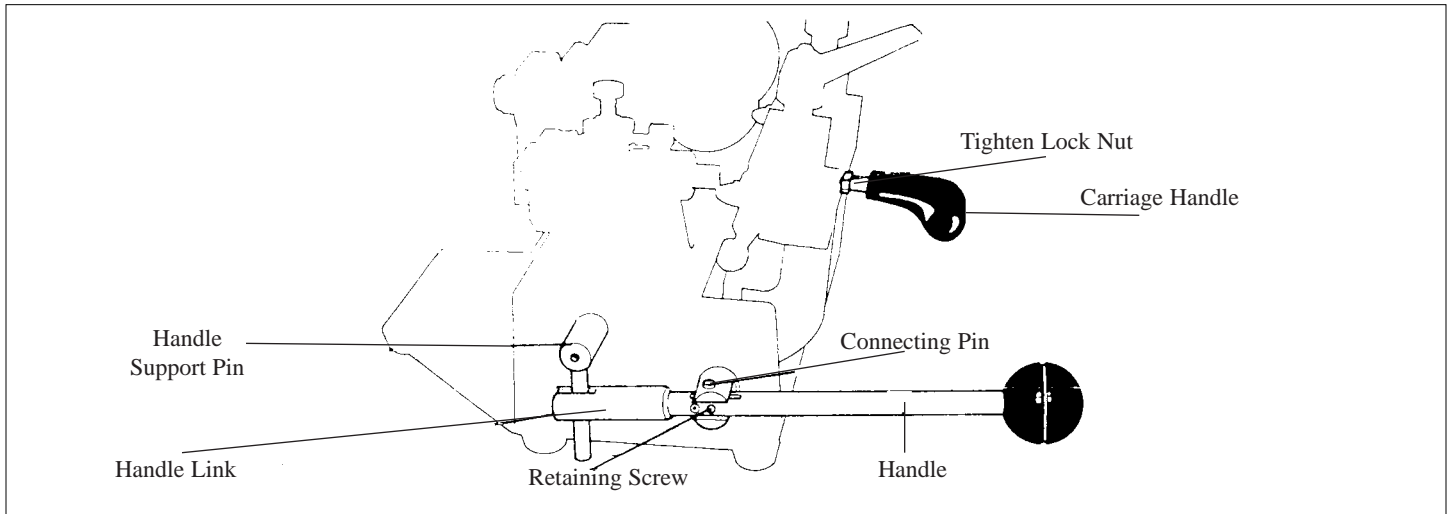

CARRIAGE HANDLE INSTALLATION

1. Insert the threaded extension arm sleeve (KD85-63) of carriage handle (KD85-62) in the threaded hole of the key machine carriage (KD85-23) and tighten (See Figure 1).
2. Secure the carriage handle by tightening the lock nut with the end wrench which is provided for you.

HANDLE INSTALLATION

1. The knob (KD85-32), the handle (KD85-31), the handle "O" ring (KD85-232) and the handle link (KD85-233) come already assembled. Carefully insert the handle link into the handle support pin (KD85-234), being careful to align the hole closest to the handle knob with the corresponding hole in the carriage shaft (KD85-24).
2. Once the holes are aligned, carefully insert the handle carriage connecting pin (KD85-231) with the milled or "flat" side facing the threaded retaining hole. It may be necessary to gently tap the handle carriage connecting pin until the milled side is visi-

ANGLE LOCKING CLUTCH LEVER HANDLE INSTALLATION

1. Insert, thread, and tighten the angle locking clutch lever handle (KD85-208) on the threaded angle locking clutch lever (KD85-207) (See Figure 2).

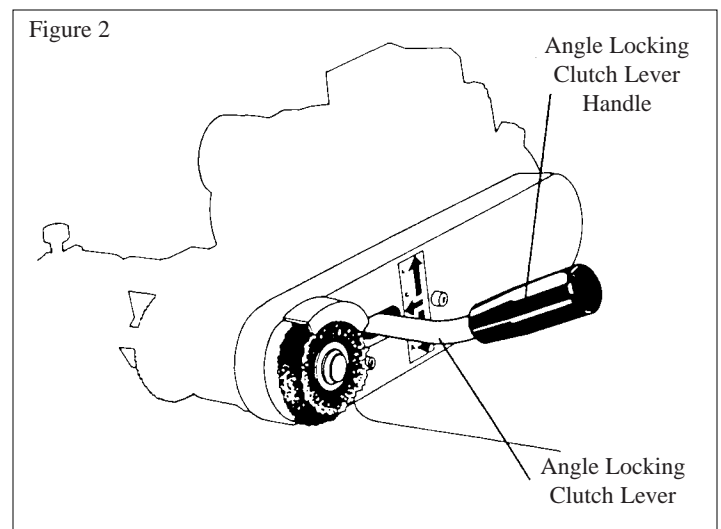

THE VERSATILITY OF THE KD85 KEY MACHINE

The KD85 key machine has been specially engineered to not only duplicate angle cut keys, but also to generate angle cut keys by code number. The unique key guide and cutting wheel tilt simultaneously in the same direction to accurately reproduce both right and left angle cuts for Medeco[®] and other specialty type keys.

The KD85 key machine also has the ability to repro-

duce standard (or center) cuts. Reproducing center cuts is necessary for duplicating and generating angle cut keys. However this ability allows the KD85 key machine to easily duplicate the many standard single and double bitted keys, which the professional locksmith encounters every day, by setting the angle locking clutch lever to the "C" or Center setting.

PROPER KEY CUTTING TECHNIQUES

Even though your KD85 key machine is designed to make key cutting fast, easy and accurate, operator skill is important. The actual mechanics of placing keys within the vise jaws are simple to learn, but there are some basics that must be followed. A properly adjusted key machine, used by someone who ignores good key cutting techniques, will **NOT** produce a good key. The way a person clamps a key into the vise jaws is critical to the accuracy of the duplicated key.

Remember - the real purpose of a duplicate key is simply to operate the lock for which it was intended. If your customers don't bring back the keys, you can assume the keys are cut correctly. If customers return the keys, you should re-examine your cutting techniques and adjustments of the machine.

Here are some important operating tips:

1. Vise jaws - clean them regularly so that no metal chips lie under the keys. **It is essential that both keys lie flat across the entire width of both vise jaws. Neither key should be tilted.**

2. Do NOT use pliers or other tools to tighten the vise jaws. Firm hand pressure is sufficient.
3. Keep the carriage shaft free of metal chips. A thin film of oil can be applied to it. The carriage should travel smoothly along its shaft.
4. NEVER touch the shoulder of a key to the side of the key guide. This will cause the shoulder of the key blank to touch the side of the cutting wheel. When this happens, some of the metal will be cut away from the shoulder of the key blank. If the resulting duplicated key is duplicated two, three, four times over, an error will accumulate and cause a non-operating key. Do not grind away the shoulder.
5. Don't run the cutter into the vise jaw; this will only dull the cutter, and reduce cutter efficiency.
6. Keep the cutter clean. Don't let any foreign objects or instruments blunt it. This cutter is a precise cutting tool and should be handled with care.
7. Lubricating of moving parts is important. Oil cups are provided to keep the cutter shaft bearings well lubricated. The carriage spindle should be lubricated with a thin film of oil.

ADJUSTMENTS

ADJUSTING FOR PROPER DEPTH OF CUT

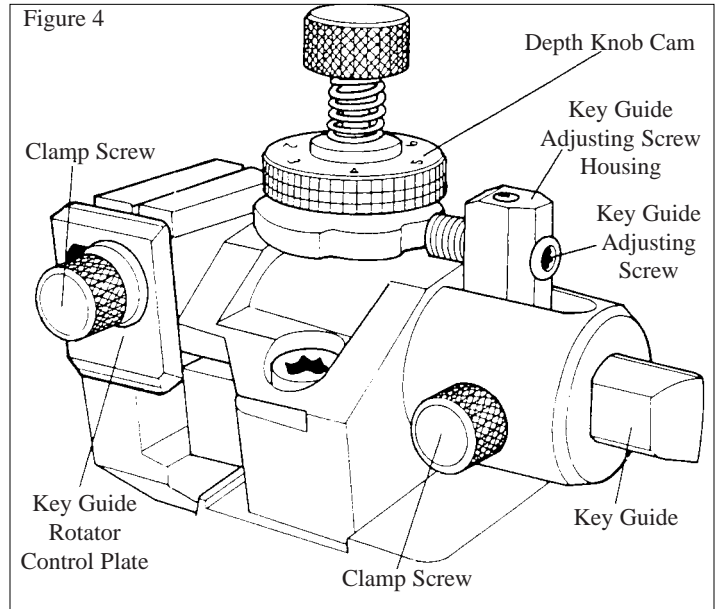
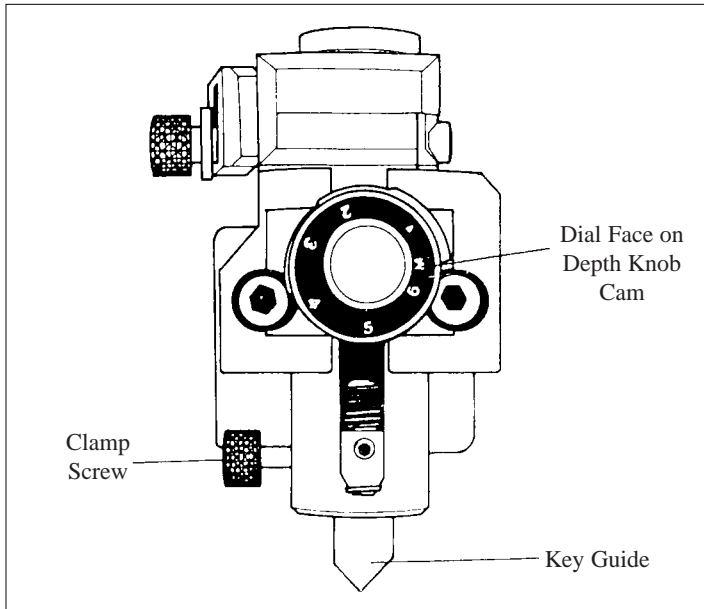

Remove the wire plug from its electrical socket for safety. Then, turn the depth knob cam so the M on its dial is directly behind the key guide adjusting screw. Push in on the key guide (to cancel out its spring loaded pre-positioning feature) and secure it in this position by tightening the clamp screw (See Figure 3).

Clamp the two service bars into the vise jaws as shown in Figure 5, making certain that both bars rest flat against the bottom of the vise and that they are butting against the ledge of each jaw. Lift the carriage toward the key guide and cutter until a flat portion of the left service bar rests against the key guide.

Turn the cutter by hand. The machine is correctly adjusted if the cutter barely grazes the top of the right

service bar. If the cutter is stopped from turning or turns freely without contacting the service bar, the cutting depth must be adjusted, as follows:

1. Loosen the set screw in the top of the key guide adjusting screw housing.
2. Turn the adjusting screw in or out as needed until the cutter barely touches the service bar (See Figure 4).
3. Securely tighten the set screw in the top of the key guide adjusting screw housing.

Note that no cutter is perfectly round, but has a high spot. Be sure to adjust with the high spot, otherwise all cuts will be slightly deeper.

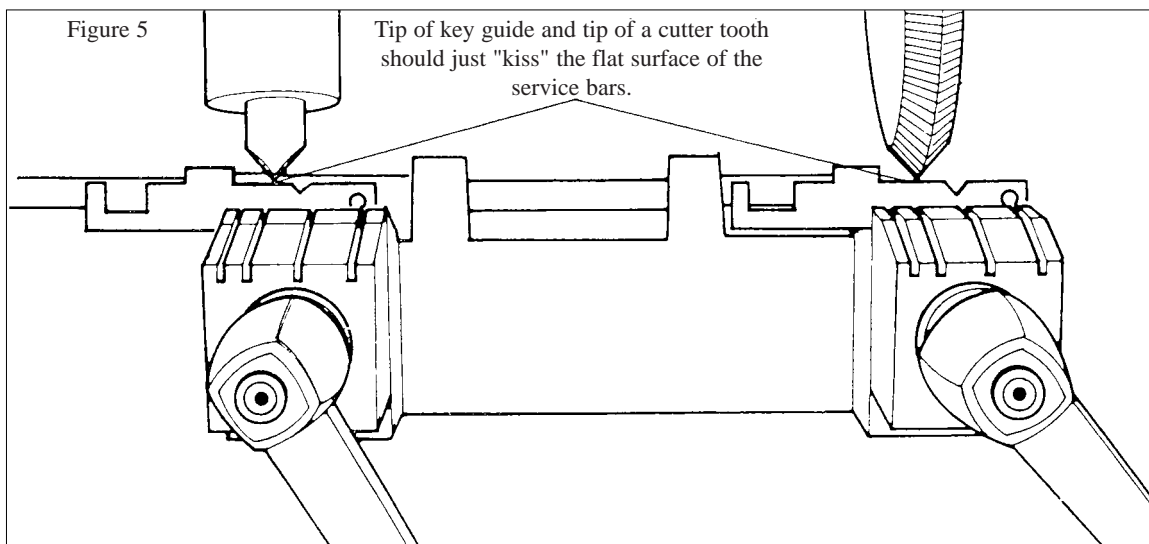

ADJUSTING FOR PROPER LATERAL DISTANCE (SPACING)

Key cutting accuracy also depends upon the spacing of the key and blank key to be the same as the distance between the key guide and cutter. To assure that the lateral distance adjustment is correct, refer to Figures 6 and 7 and proceed as follows:

1. Insert the service bars vertically into a slot of each upper vise jaw. Use the same slot in each jaw.
2. Roll up the setting gauge and place the finger against the service bars. Both fingers should touch. If they do not, loosen the small set screw under the right finger and push this finger until it contacts the service bar. Tighten the set screw. **NOTE!** This action

assures the setting gauge is aligned with the vise jaws.

3. Clamp a service bar into the left vise jaw. Do not butt its bottom shoulder against the carriage; this shoulder should be 1/8" from the carriage. Roll up the setting gauge so the left finger contacts the top shoulder of the service bar.
4. Clamp the other service bar into the right vise jaw, butting its top shoulder against the right finger of the setting gauge. Lower the setting gauge.
5. Raise the carriage and drop the key guide into the V notch of the left service bar. The cutter should drop into the V notch of the right service bar. Both the key guide and the tip of a cutter wheel tooth must fit exactly into their V grooves or the setting will not be accurate. Turn the cutter by hand to confirm the fit.
6. If the guide and cutter don't seat exactly into each "V" groove, the distance between the key gauge fingers must be altered. This can be accomplished by repositioning the right service bar. Loosen the Allen set screw securing the right finger. Move the service bar so its V notch will accept the cutter and tighten the vise jaw to firm this position. Push the right finger to contact the service bar shoulder. Retighten the screw.

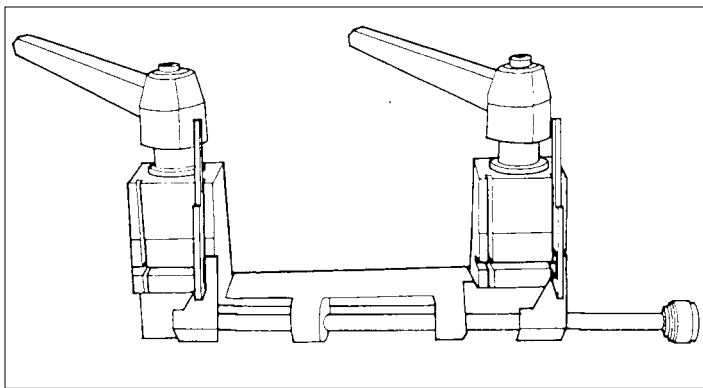

Figure 6

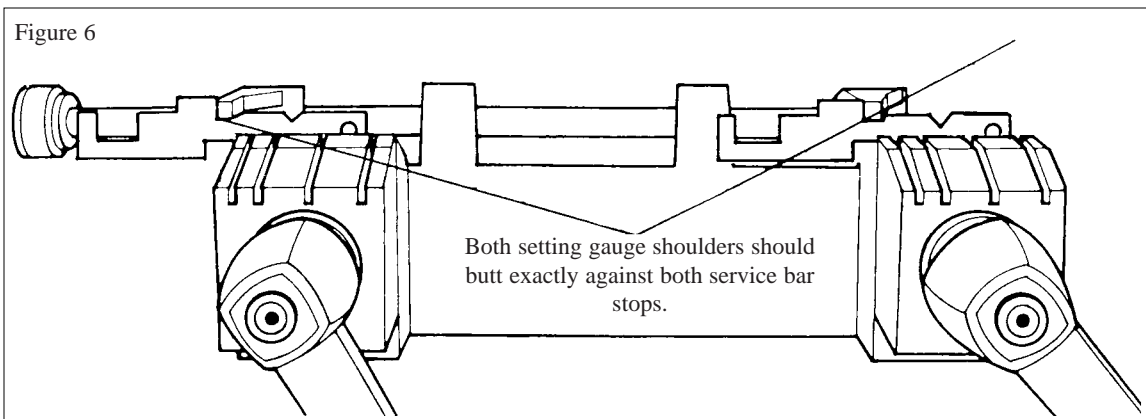
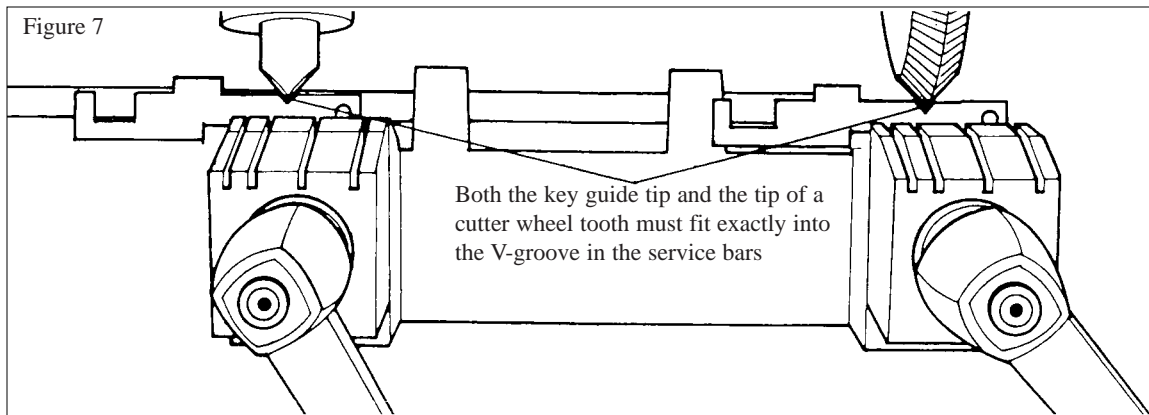

Figure 7



HOW TO DUPLICATE KEYS

7. If the right finger has reached the limit of its travel and cannot be moved further, then reposition the left finger of the setting gauge.
8. If the above movements do not produce the correct

spacing adjustment, the machine must be returned to the factory. Do not attempt to alter the distance between the cutter and key guide with shims or by changing the setting of the cutter spindle.

DUPLICATING STANDARD CENTER CUT KEYS

1. Insert the pattern key into the left vise jaw.
2. Roll up the setting gauge assembly. Make sure the upper shoulder of the pattern key is butted up against the left finger of the setting gauge. Tighten the pattern key in the vise, using the clamp assembly handle. Set the key blank against the right finger of the setting gauge and tighten the key blank in the right vise. Roll down the setting gauge assembly making sure it does not interfere with key cutting (See Figure 8).
3. Move the key guide rotator control plate to the left or "Copy" position and tighten securely using its clamp screw (see Figure 4). Make sure the key guide is butted up against the depth knob cam (See Figure 3). It is important to note that key duplication must only take place after the depth knob cam has been set to M. Also, set the angle locking clutch
4. Activate the key machine by pressing the ON-OFF switch at the top of the key machine motor. Lift the handle in your left hand while holding the carriage handle in your right hand.
5. Using both handles, raise the carriage and carefully glide the pattern key across the key guide. All the cuts in a standard center angle single bitted key blank can be cut in one pass. This movement will be dupli-

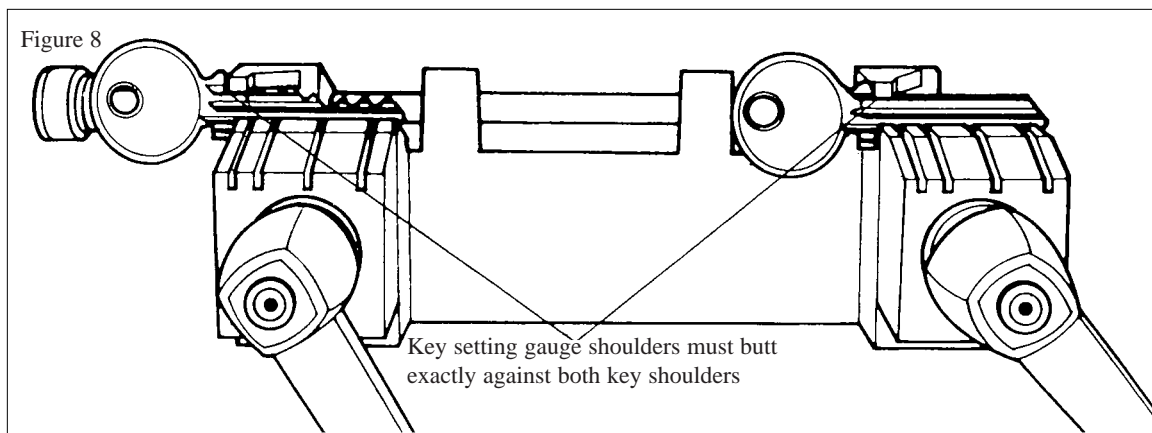

3. Move the key guide rotator control plate to the left or "Copy" position and tighten securely using its clamp screw (see Figure 4). Make sure the key guide is butted up against the depth knob cam (See Figure 3). It is important to note that key duplication must only take place after the depth knob cam has been set to M. Also, set the angle locking clutch

cated by the action of the key blank against the cutter. As a result, the key blank will become a duplicate of the pattern key. A double bitted key blank will have to be removed, and reversed, so the uncut side of the key blank can be cut using the same procedure as the first side. It may not be necessary to reverse the pattern key if the cuts are the same on both sides.

DUPLICATING ANGLE CUT KEYS

Making angle cut keys must be performed one cut (left, center, or right) at a time. Do NOT glide the pattern key and the key blank across the key guide and cutter, as with standard center cut keys.

Determine visually the angles of the individual key cuts. Assume for purposes of demonstration that the

angles of the cuts are as follows: R-C-L-R-C-L, (where R=Right, C=Center, and L=Left). Make sure the key guide rotator control plate is in the left or "Copy" position and the key guide is locked against the depth knob cam. Also, the depth knob cam must be set to M. Setting to any other number will cause deep cuts.

Pull the angle locking clutch lever handle towards you and lift upward in the direction of the angle cut arrow labeled “R” (See Figure 9). Turn on the machine.

Line up the first cut of the pattern key with the key guide, and carefully make the first cut ONLY. Line up the fourth cut, which also has a right angle, and make this fourth cut only, in the same manner.

Use the angle lever handle to push downward

toward the angle cut arrow labeled “L”. Make the two left angle cuts (position 3 and 6) in the same manner. Finally, position the angle lever handle at the position marked “C”, and make the remaining two standard center cuts (position 2 and 5).

Note that, when the angle lever handle is moved, both the cutter and the key guide will tilt to the same angle as a synchronized unit.

Figure 9

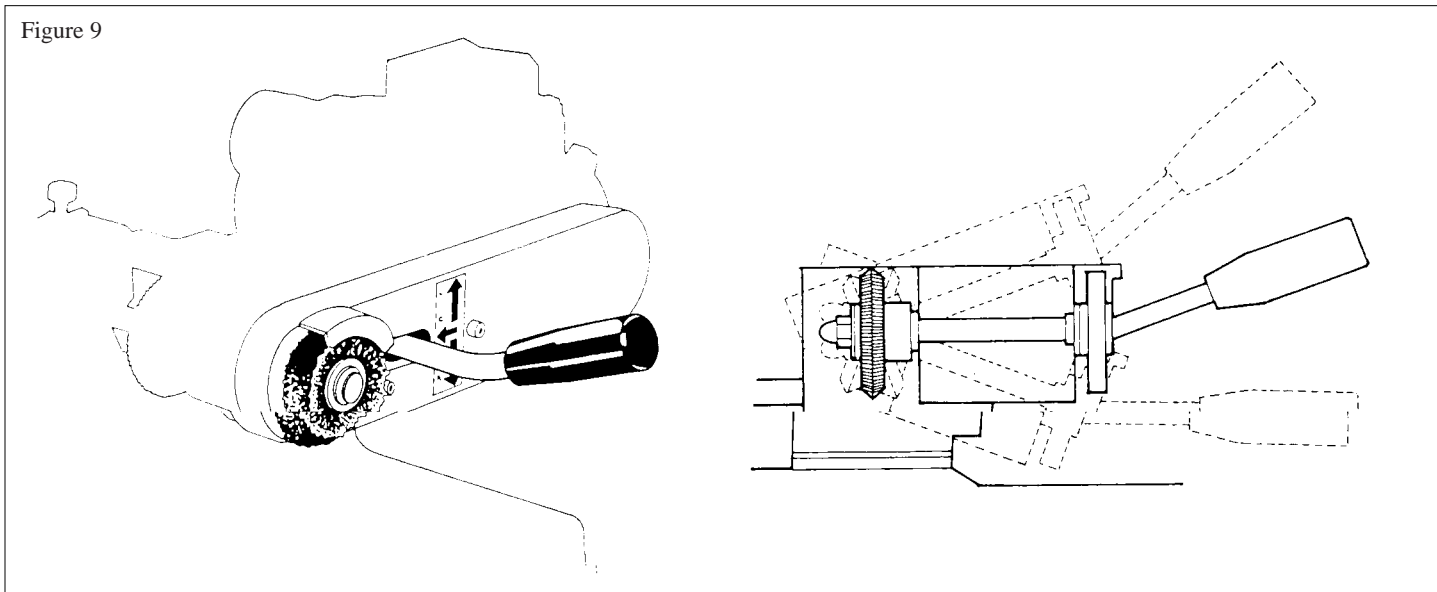

CUTTING ANGLE KEYS BY CODE

The KD85 will originate an operating key by code (without a pattern key). Depths are determined by the depth knob cam - 1 equals depth 1, 2 equals depth 2, etc. Spacing is designated by the markings on the spacing plate, which is clamped into the left vise, lining up with the key guide. Also, the key guide is loosened, allowing it to pre-position into a spacing location before the actu-

al cut is made in the key blank.

Before making an angle cut by code, the angle of each cut must be known as well as the depth. Once this is known, proceed as follows.

1. Loosen the clamp screw securing the key guide rotator control plate. Move the key guide rotator control plate

Figure 10

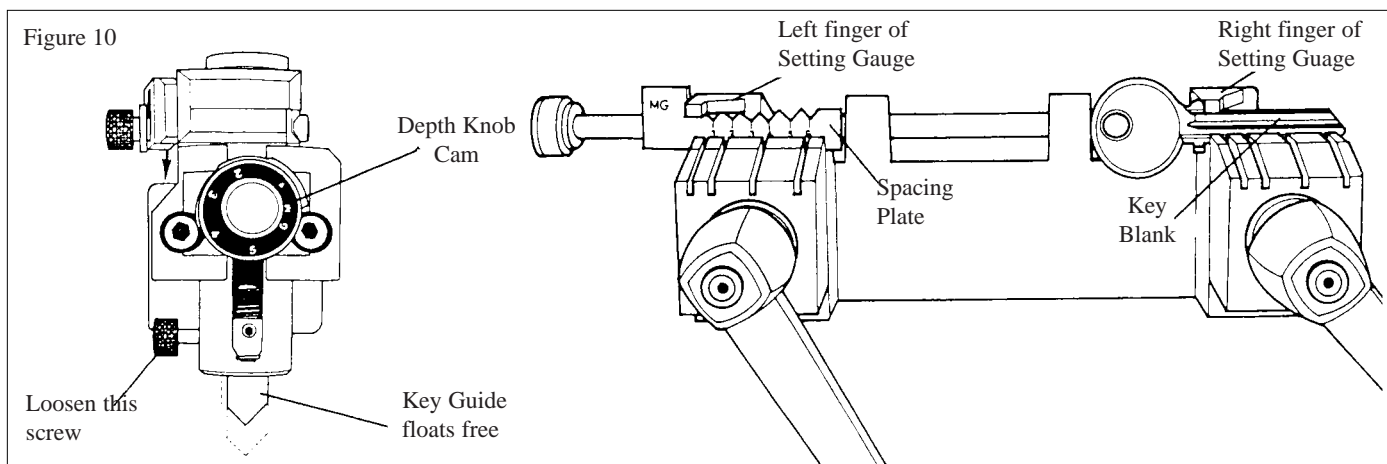

REPLACEMENTS

- toward the direction of the cutter. Tighten the clamp screw.
- Loosen the clamp screw securing the key guide. This will allow the key guide to “float freely”. Do not retighten this clamp screw.
 - Loosen the left vise jaw. Insert the desired spacing plate (KD85-SMG for larger keys or KD85-SMP for smaller keys). Tighten securely.
 - Insert the key blank in the right vise jaw.
 - Roll up the knob setting gauge and set its left finger against the shoulder of the spacing plate. Set the key blank in the same manner that is, the right finger of the setting gauge against the shoulder.
 - Loosen the key guide barrel retaining ring. Turn the depth knob cam to the desired depth (#1 - #6).
 - Turn on the machine.
 - Raise the carriage and carefully insert the key guide into the number one position on the spacing plate, and gently press upward until the cut is completed. The cut in the key blank will be made according to the specifications prescribed by the manufacturer.

Continue to follow this procedure for all the spacings and depths listed in the original code. Be sure to note the left angle, right angle, and standard center cuts, and to rotate the depth knob cam to the proper number.

REPLACING THE CUTTER AND THE BRUSH

NOTE: Use the positioning bar, the Allen wrench, and the end wrench included with the KD85 key machine to perform the following operations.

eter deburring brush. Securely tighten the brush shoulder screw using the Allen wrench.

BRUSH REPLACEMENT PROCEDURE

Insert the positioning bar into the hole to the right of the cutting wheel in the cutter spindle. Loosen and remove the brush shoulder screw using the Allen wrench which is provided. Reinstall the new 2" diam-

CUTTER REPLACEMENT PROCEDURE

Insert the positioning bar into the hole to the right of the cutting wheel in the cutter spindle. Use the end wrench to loosen and remove the cutter acorn nut that secures the cutting wheel. Reinstall the new cutting wheel. Then, insert the positioning bar in the cutter spindle, and use the end wrench to tighten the cutter nut.

