



# **OWNER'S MANUAL**

OX1100 Series

## Installation and Service Manual

INTRODUCTION  
SPECIFICATIONS  
UNPACKING  
MOUNTING  
ELECTRICAL  
OPERATION  
MAINTENANCE  
REPLACEMENT PARTS  
TROUBLESHOOTING

\*\*\*IMPORTANT\*\*\*

---

THIS MANUAL CONTAINS PRECAUTIONARY STATEMENTS RELATING TO WORKER SAFETY. READ AND SAVE THIS MANUAL COMPLETELY AND COMPLY AS DIRECTED. ALL THE POTENTIAL HAZARDS OF DUST AND MIST CONTROL SYSTEMS AND EQUIPMENT ARE IMPOSSIBLE TO LIST; THEREFORE, OBTAIN THE SERVICES OF A PROFESSIONAL INSTALLER. A FIRE PROTECTION EXPERT SHOULD BE OBTAINED IN THE EVENT THE PRODUCT IS INTENDED FOR USE THAT PRESENTS A POTENTIAL RISK OF FIRE OR FIRE PROPAGATION. REFER TO APPROPRIATE AUTHORITIES, AND DISCUSS YOUR INTENDED USE WITH YOUR LOCAL DISTRIBUTOR OR BLUE OX. WORKERS HANDLING EQUIPMENT OR SYSTEMS SHOULD BE INSTRUCTED TO CONDUCT THEMSELVES IN A SAFE MANNER.

---

RETAIN THESE INSTRUCTIONS FOR FUTURE REFERENCE.

## SPECIFICATIONS OF THE BLUE OX1100

<b>Cabinet</b>	<b>16 GA Cold Rolled Steel</b>		
<b>Finish</b>	<b>Brown Polyester Powder Coating Paint (Circuit Blue and Black also available)</b>		
<b>Size</b>	<b>Standard</b>	<b>44" L</b>	<b>20" W</b> <b>15" H</b>
<b>Unit Options</b>	<b>1100 Standard</b> <b>1100-CF (2" Carbon After Filter)</b> <b>1100-CC (Carbon Canister Bank - 18 lbs.)</b> <b>1100-HE (HEPA Filter)</b>		
<b>Shipping- Weight</b>	<b>Standard.....</b>	<b>95 lbs.</b>	
	<b>Carbon After Filter.....</b>	<b>100 lbs.</b>	
	<b>18 lb. Carbon Bank.....</b>	<b>131 lbs.</b>	
	<b>HEPA Filter.....</b>	<b>125 lbs.</b>	
<b>Power</b>	<b>115 Volt - 3.5 AMPS</b>		
<b>Capacity</b>	<b>Max 1100 CFM Standard – Max 875 CFM (HEPA)</b>		
<b>Motor</b>	<b>PSC Type 1/5 H.P. Direct Drive with thermal overload @ 48 dBA</b>		
<b>Switch</b>	<b>Variable Speed Switch</b>		
<b>Blower</b>	<b>9 by 9 Direct Drive Centrifugal Forward Curve</b>		
<b>Grille</b>	<b>Four way individually adjustable blades</b>		
<b>Bag Size</b>	<b>Standard/Carbon Filter</b>	<b>-15" x 20" x 24" - 95% or 65% - 6 pocket bag filter</b>	
	<b>HEPA/Carbon Bank</b>	<b>-15" x 20" x 12" - 95% or 65% - 6 pocket bag filter</b>	
<b>Pre-filter</b>	<b>15" x 20" x 1" Washable Foam pre-filter</b>		
<b>(Optional)</b>	<b>15" x 20" x 1" Pleated pre-filter (Beverage Board Frame)</b>		
<b>(Optional)</b>	<b>15" x 20" x 1" Aluminum Mesh pre-filter (Washable)</b>		
<b>Options</b>	<b>Silencer – Reduces Db. by 6-8</b> <b>Magnehelic Pressure Gage (shows when to change filters)</b> <b>Eye Bolts – Installed by factory for easy mounting</b> <b>Eye Bolt Kit – Includes Eye Bolts (4), Chain, and Q-Link</b> <b>L-Brackets – Ideal for Wall Mounting</b> <b>Drain Plug – Oil / Mist Drain via Hose Barb Fitting</b>		
<b>Warranty</b>	<b>Three years on all parts, does not include filters</b>		

## SAFETY RULES

Follow all electrical and safety codes as well as the National Electrical Code (NEC), National Fire Protection Association (NFPA), and the Occupational Safety and Health Act (OSHA). Qualified personnel should perform all electrical connections and wiring only.

National Fire Protection Association (NFPA) standards require specific duct design and dust collector configuration when collecting potentially reactive metal dusts, such as aluminum, magnesium, and other materials. NFPA also covers other dusts such as grain and plastics, etc. A guideline for determining the precautions to be taken can be found in NFPA 497. Other NFPA standards may apply to your specific application. Consult current NFPA standards, available for NFPA, 1 Batterymarch Park, Quincy, MA, 02269, 800-344-3555, for applicable safeguards which may be required for the Installation, Operation, and Service of this product.

Additional references are the Uniform Building Code and the Uniform Mechanical Code.

### WARNING

1. Avoid mixing combustible materials such as (but not limited to) buffing lint, paper / wood dust, aluminum or magnesium with dust generated from the grinding of ferrous materials. This creates a potential for fire due to the mixing of sparks and combustible materials.
2. Under no conditions should the machine operator be allowed to put lit cigarettes or any burning object into this or any dust/mist control system.
3. Installation of this unit in applications where there is a chance for heated and/or flammable materials to enter the unit should be evaluated to determine if a fire protection/extinguishing system should be installed. Federal, state or local codes, a required by organizations such as NFPA and Factory Mutual Insurance or your insurance carrier may require such a system. BLUE OX can offer basic guidelines for such an installation; however, **final installation design is the responsibility of the filtration unit Owner/User.**
4. Explosion relief vents are required on some applications. Consult with an insurance underwriter or an NFPA manual to determine proper vent size ratio. Dust or mist collectors must be located outdoors unless otherwise indicated by NFPA standards. Dust and mist collectors **DO NOT CONTAIN EXPLOSION RELIEF VENTS** as shipped from the factory and must be field installed per NFPA standards.

**ALWAYS USE BLUE OX REPLACEMENT FILTERS & PARTS TO MAINTAIN WARRANTY.  
TO ORDER REPLACEMENT PARTS CALL 866-455-2135 OR EMAIL [info@aircleaningspecialists.com](mailto:info@aircleaningspecialists.com).**

### BLUE OX LIMITED WARRANTY

Air Cleaning Specialists, Inc. warrants all products sold, only to purchasers for use in business or for resale, against defects in workmanship or materials under normal use for three years after date of purchase from Air Cleaning Specialists, Inc. This three year warranty does include standard warranties from purchased parts such as blowers, motors, valves, etc. All purchased items will fall under the manufacturers' standard warranty. Any part which is determined to be defective in material or workmanship and returned to Air Cleaning Specialists, Inc. or authorized service facility, as Air Cleaning Specialists, Inc. designates, shipping cost prepaid, will be, as the exclusive remedy, repaired or replaced, at Air Cleaning Specialists, Inc. option. Any liability for consequential and incidental damage is expressly disclaimed. Air Cleaning Specialists, Inc. liability, in all events, is limited to and shall not exceed, the purchase price paid. Title and risk of loss pass to buyer on delivery to the common carrier. If product is damaged in transit, recipient must file claim with carrier. Air Cleaning Specialists, Inc. will make a good faith effort for prompt correction or other adjustments with respect to any product that proves to be defective within the warranty period.

### DISCLAIMER

Although instructions and recommendations are included for installation or your mist or dust collector equipment, the manufacturer does not assume responsibility for the installation of this equipment nor shall be held liable for direct or consequential damages resulting from improper methods, structural failure or inadequate supports.

### SAFETY

**READ AND SAVE THIS MANUAL COMPLETELY AND COMPLY AS DIRECTED. THIS MANUAL CONTAINS PRECAUTIONARY STATEMENTS RELATING TO WORKER SAFETY. WORKERS HANDLING EQUIPMENT OR SYSTEMS SHOULD BE INSTRUCTED TO CONDUCT THEMSELVES IN A SAFE MANNER. ALL THE POTENTIAL HAZARD OF DUST AND MIST CONTROL SYSTEMS AND EQUIPMENT ARE IMPOSSIBLE TO LIST. THEREFORE, OBTAIN THE SERVICES OF A PROFESSIONAL INSTALLER. A FIRE PROTECTION EXPERT SHOULD BE OBTAINED IN THE EVENT THE PRODUCT IS INTENDED FOR USES, WHICH PRESENT A POTENTIAL RISK OF FIRE OR FIRE PROPOGATION. REFER TO APPROPRIATE AUTHORITIES, AND DISCUSS YOUR INTENDED USE WITH AIR CLEANING SPECIALISTS, INC.**

### Initial Inspection

If your new BLUE OX units were shipped in by truck you should inspect the carton for damages or possible shortages. If there are any signs of possible shipping damages, unpack the units and make a note of the shortage or damage on the freight bill before signing it. If the carton is opened at a later time and there is damage to the unit, you should file a concealed damage claim with the delivery carrier. They are responsible for any damages in shipment or shortages that were actually shipped.

### Installing Your New BLUE OX Units

All installations must meet all electrical or mechanical building codes that may apply in your particular area. If there are no local requirements, you should follow the National requirements. If the optional *Drain Plug* was installed in your unit, you can connect an appropriate 3/8" I.D. rubber hose for oil/mist routing.

All chains, hooks, bolts or other items used in the installation must be at least strong enough to support FOUR times the weight of each unit. Unit weights are as follows:

BLUE OX1100 .....	90 lbs.
BLUE OX1100-CF .....	95 lbs.
BLUE OX1100-HE .....	105 lbs.
BLUE OX1100-CC.....	115 lbs.

### **Methods for Mounting your OX1100 Unit**

There are many different ways to install your units. The most common method of installing the units is to support them from the ceiling structure with four chains. If you are going to utilize this method, you should have 4 holes drilled down through the top of the unit approximately 6" from each end and 1" from each side of the unit. The factory will then install Eye-Bolts that can be used to attached chain or rod. An eye bolt kit is available at an additional cost, and includes 5' sections of chain and Q-links.

The top end of the chains must be secured to the ceiling structure in a safe and acceptable manner.

Another typical method for installation is a dual L-Bracket mount, which is ideal for wall mounting.

The next page includes sketches indicating possible methods of mounting your OX1100 cabinets. Please ensure all installations are secure and meet all local, state, and federal codes. Be sure your unit is connected to the proper voltage and is protected by correct size fuses or breakers.

# Blue OX1100 Installation, Mounting Options

## Option 1 – Mounting w/ Eye Bolts

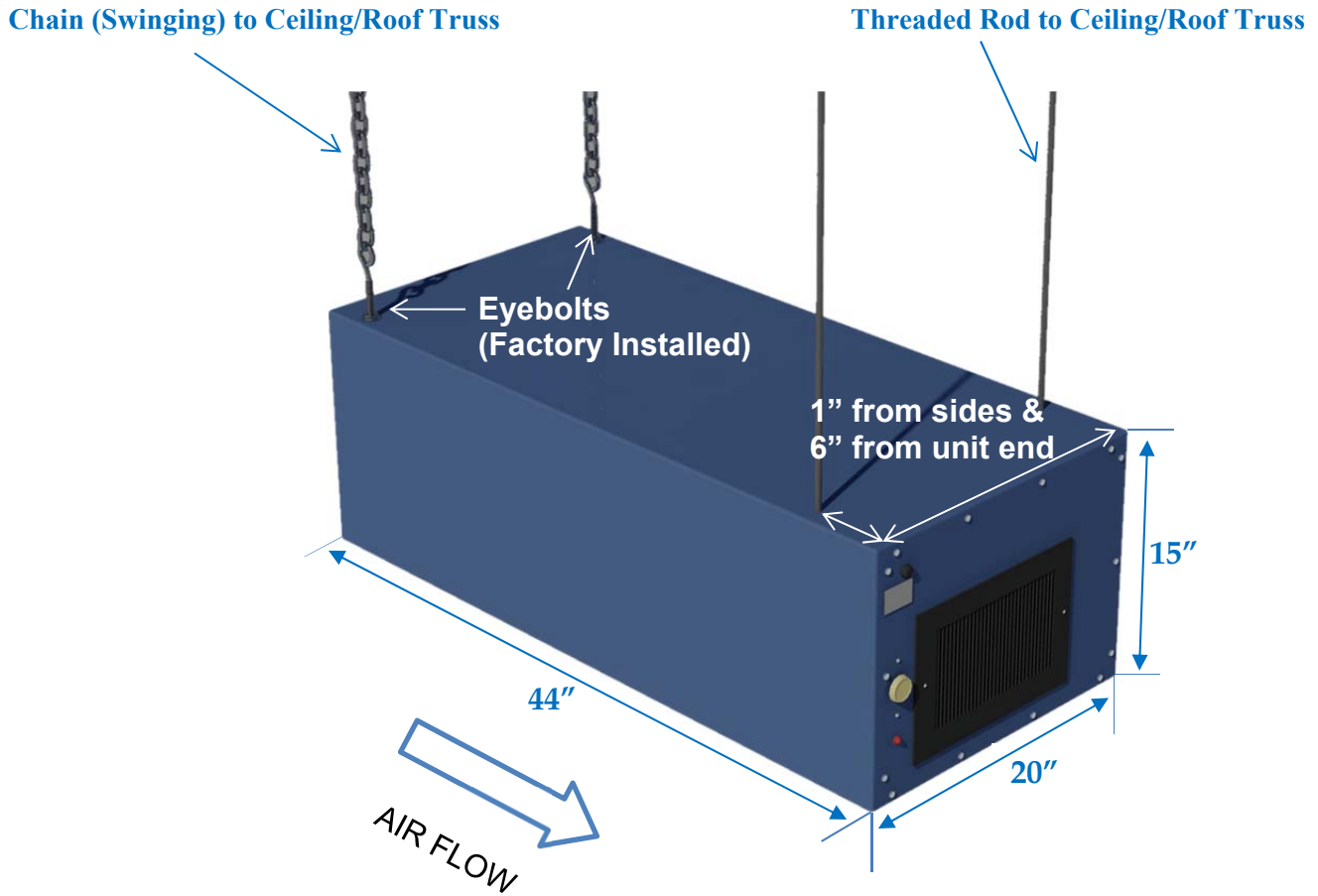

Standard Filtration Unit Weight = 95 Lbs.

Electrical: 115V AC Single Phase with 12' power cord drawing 3.5 Amps

Option 2 – Wall Mounting w/ L-Brackets

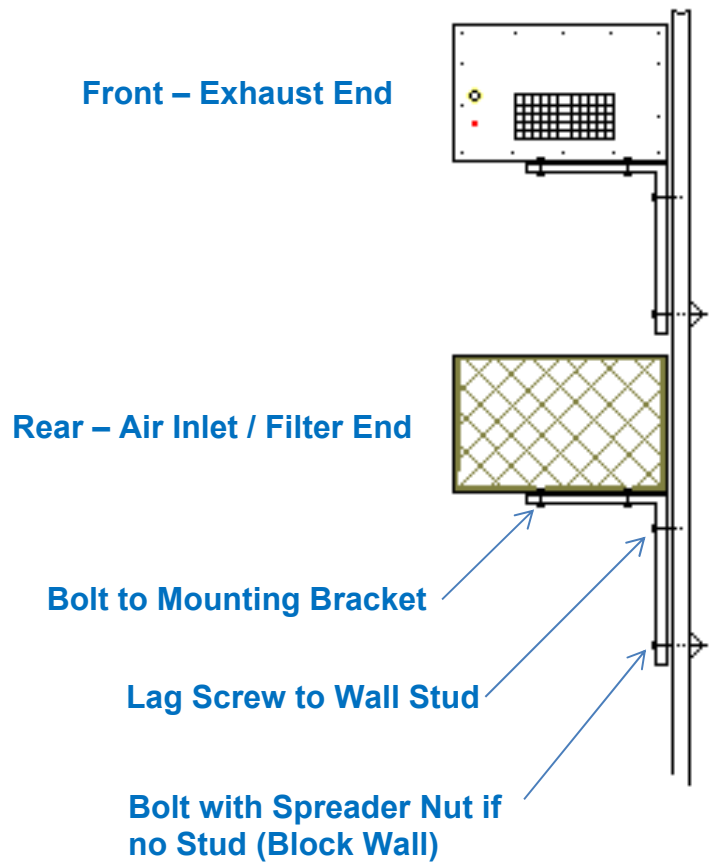

L-Bracket Installed



L-Brackets should be 6” from the ends of the unit.

BLUE OX products are designed to improve your environment. OX1100 series collects dust, smoke, oil mist, oil smoke, and other atmospheric pollutants in industrial plants, shops, schools, and factories with high efficiency, 2 or 3 stage filtration. It is a complete air filter packaged unit that can be installed easily and used as a free hanging air filter unit to clean the ambient pollutants, smoke and haze.

The OX1100 consists of a 1" foam pre-filter that traps dust and larger particles. The second stage, micro-glass multi-pocket bag filter has 98% arrestance and 95% efficiency on the atmospheric dust spot test, removing smoke and other submicron size particles from the air. Changing out the filters is easy as it requires no tools. The 1" foam pre-filter pulls from the unit and can be washed. The foam pre-filter can be used several times before needing replacement. Allow the foam filter to air dry for best results. The main filter is located directly behind the 1" foam pre-filter and pulls out also. For light odors, there is an optional 2" 50% bypass charcoal filter available.

### **MOTORS**

All direct drive motors are protected with automatic restart overload protection. All belt driven units must be protected externally.

### **OPERATION**

Do not operate your units without filter for more than a few minutes at a time.

### **MAGNEHELIC PRESSURE GAGE OPTION**

This is an option to help determine when to change the filters. As the bags fill with contaminants, the needle on the gage will rise. We recommend changing the bags between 1.25 – 1.50 above the reading with clean filters. It is normal to change the pleated twice (or more) as much as the inside bag filter. After the pleated has been change and there is no longer a drop in pressure, then it is time to change main filter. The reading may vary depending upon the contaminants. Please consult your Sales Engineer for further information.

### **FILTERS**

All units are equipped with replaceable type media filters. In some cases, where contaminants being picked up are dry, it is possible to wash the pre-filters and reuse them. Filters are available in a number of different degrees of efficiencies. The filters in your new BLUE OX unit have been selected by your representative to best collect your particular type of contaminant.

Media type filters actually become more efficient as they load with contamination. However, as the filters load up, the air flow volume will decrease and eventually will reach a point where they must be replaced to restore the original air flow. Changing the filters in your new BLUE OX air cleaner is really easy. Old filters are simply pulled out of the entrance end of the unit and new filters are installed. No tools are required. Turning the unit on when installing new filters will help to pull them into place.

### **GENERAL NOTE: CLEANING AND INSPECTION OF CABINET**

After the dirty components have been removed, inspect the cabinet interior. Remove foreign material, wipe interior, and clean all filter seating surfaces.

When installing new filters the opening in the bag filter should be in a vertical position. Be sure the cloth part of the bag does not bunch up between the bag header and the angle iron filter stops on the cabinet. Replacement filters can be supplied by your representative.

### **LOUVERS**

Four way lovers are provided on all units to permit you to direct the discharge air away form pilot lights on heaters and to help you obtain the best air flow pattern for maximum cleaning.

### **PARTS**

**ALWAYS USE BLUE OX REPLACEMENT FILTERS & PARTS TO MAINTAIN WARRANTY.**

**TO ORDER REPLACEMENTS PARTS: CALL 866-455-2135 | EMAIL [info@aircleaningspecialists.com](mailto:info@aircleaningspecialists.com)**

**826 Horan Drive, Fenton, MO 63026**

# OX1100 Wiring Diagram

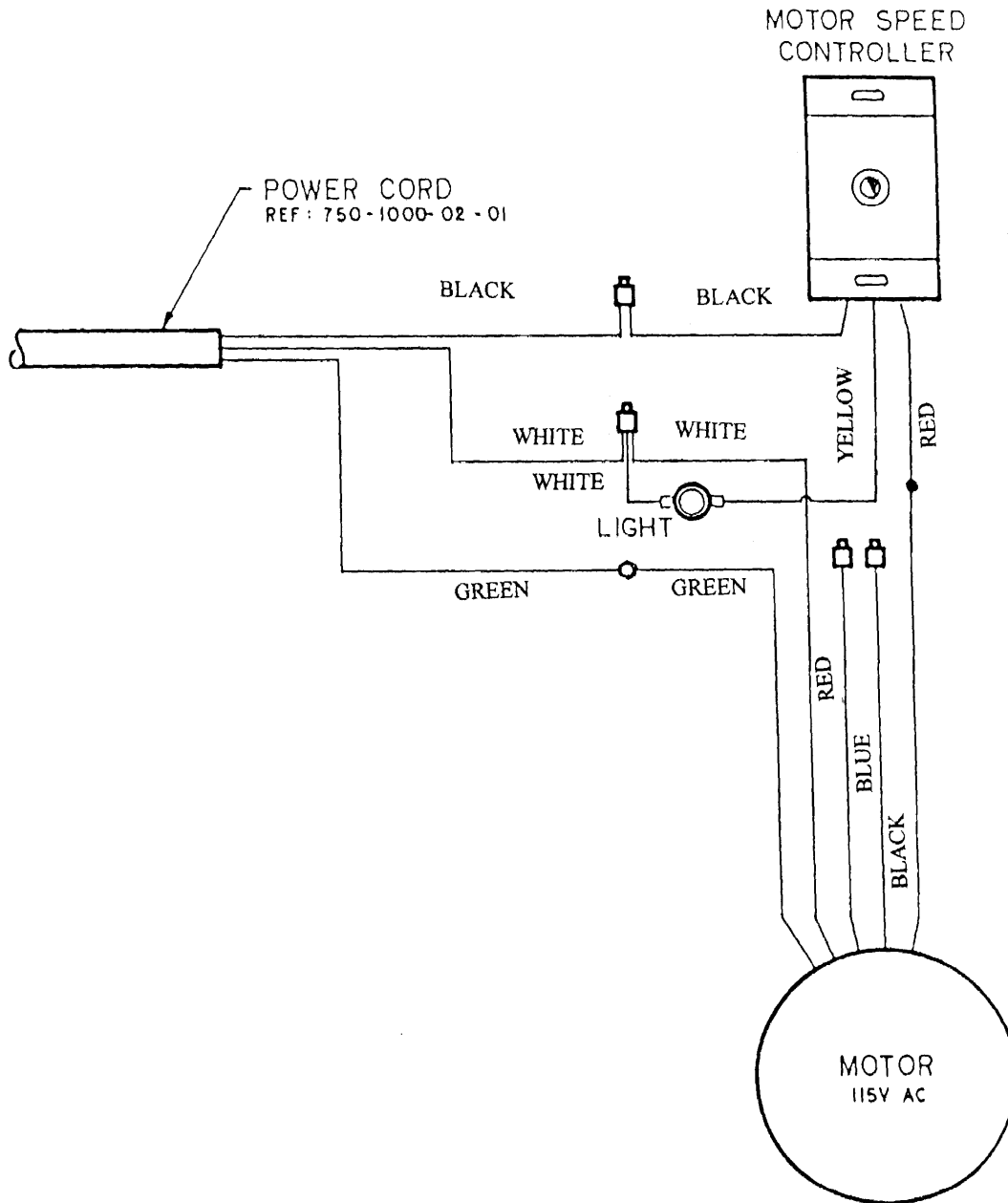



## OX1100 Replacement Parts

ITEM	PART #	DESCRIPTION
1	11-1000	1/5 HP DIRECT DRIVE MOTOR
2	11-1500	9" COMPLETE BLOWER
3	11-1501	BLOWER WHEEL ONLY
4	11-1502	9" MOTOR MOUNT
5	11-2000	POWER SWITCH
6	11-2002	12' POWER CORD
7	11-3000	4 WAY ADJUSTABLE LOUVER

## OX1100 Replacement Filters

ITEM	PART #	DESCRIPTION
1	SP9506-5012	15" X 20" X 12" - 95% - Bag Filter
2	SP9506-5024	15" X 20" X 24" - 95% - Bag Filter
3	SP6506-5012	15" X 20" X 12" - 65% - Bag Filter
4	SP6506-5024	15" X 20" X 24" - 65% - Bag Filter
5	BOF-5001-FM	15" X 20" X 1" Foam Pre-Filter
6	HE40-5001	15" X 20" X 1" Pleated Pre-Filter
7	BOF-5001-AM	15" X 20" X 1" Aluminum Mesh Pre-Filter
8	BOF-5002-CF	15" X 20" X 2" Carbon After Filter
9	BO11-121812HEPA	12" X 18" X 12" HEPA Filter (Frame 15x20)

**ALWAYS USE BLUE OX REPLACEMENT FILTERS & PARTS TO MAINTAIN WARRANTY.  
TO ORDER REPLACEMENT PARTS:**

**Air Cleaning Specialists, Inc.**

826 Horan Drive - Fenton, MO 63026

CALL 866-455-2135 | EMAIL [info@aircleaningspecialists.com](mailto:info@aircleaningspecialists.com)

## Troubleshooting

<b>Problem</b>	<b>Remedy</b>
<b>Motor starts with a whine and does not reach full speed.</b>	If three-phase powered, stop motor immediately. It may be “single phasing” and will overheat, possibly damaging internal windings. Check fuses and/or wires for an interruption in one of the lines. The motor may be operating on two phases only.
<b>Motor makes a scraping or knocking noise.</b>	Check motor cooling fan and its cover. It may have been damaged or shifted in transit and motor fan is rubbing. Check for loose blower wheel on motor shaft – tighten if necessary.
<b>No suction or pressure, or some suction but not as required (low or no airflow).</b>	Check and open all dampers, if installed. Check ducting for blockage, if installed. Check for dirty or blocked filters (refer to Maintenance section). Check rotation of fan.
<b>Excess vibration.</b>	Check structural support members. Tighten all bolts on legs and cross braces. Make sure entire structure is solid. Check for loose blower wheel – tighten if necessary.
<b>Contaminants blowing through unit.</b>	Check for torn or damaged filters. Check filter seals. If carbon module is used, make sure filter sock in place. Check door seals.
<b>Motor over-amping nameplate.</b>	Access door open, close doors. Incorrect filters or no filters in the unit. Ductwork faulty.

If after performing the above TROUBLESHOOTING the unit fails to perform to specifications, contact for further assistance:

**Air Cleaning Specialists, Inc.**

826 Horan Drive - Fenton, MO 63026

CALL 866-455-2135 | EMAIL [info@aircleaningspecialists.com](mailto:info@aircleaningspecialists.com)

## Motor Trouble Guide

The purpose of this guide is to suggest common answers to electrical problems. The information is not all-inclusive and does not necessarily apply in all cases. When unusual operating conditions, repetitive failures, or other problems occur, consult an electric motor service firm for assistance.

<b>Trouble</b>	<b>Cause – What To Do</b>
<b>Motor fails to start.</b>	<p><u>Blown fuses</u> – Replace with time-delay fuses or circuit breakers. Check for grounded winding.</p> <p><u>Low voltage</u> – Use higher voltage tap on transformer terminals, increase wire size. Check for poor connections.</p> <p><u>Improper line connections</u> – Check connections against diagram supplied with motor.</p> <p><u>Overload tripped</u> – Check and reset relay in starter. Check heater rating against motor nameplate current rating. Check motor load. If the motor has manual re-set thermal protector, check if it has been tripped.</p> <p><u>Motor may be overloaded</u> – Reduce load. Increase motor size.</p> <p><u>If permanent split capacitor motor, capacitor may be open</u> – Indicated by humming sound. Replace run capacitor. See nameplate for correct value.</p> <p><u>Defective motor or starter</u> – Repair or replace.</p>
<b>Motor stalls.</b>	<p><u>Overloaded motor</u> – Reduce load or increase motor size.</p> <p><u>Low motor voltage</u> – See that nameplate voltage is maintained.</p>
<b>Motor does not come up to speed.</b>	<p><u>Not applied properly</u> – Consult motor service firm for proper type. Use larger motor.</p>
<b>Motor takes too long to accelerate.</b>	<p><u>Excess loading; high inertia load</u> – Reduce load. Increase motor size.</p> <p><u>Inadequate wiring</u> – Increase wire size. Check for poor connections.</p> <p><u>Applied voltage too low</u> – Reconnect to a higher transformer tap. Increase wire size. Check for poor connections.</p> <p><u>Defective motor</u> – Repair or replace.</p> <p><u>Inadequate starting torque</u> – Replace with higher horsepower motor.</p>

<p><b>Motor vibrates or is excessively noisy.</b></p>	<p><u>Motor misaligned</u> – Realign.  <u>High voltages</u> – Check wiring connections, transformer.  <u>Worn, damaged, dirty or overloaded bearings</u> – Replace, check loading and alignment.  <u>Loose or defective or out-of-balance air mover</u> – Tighten set screw(s), repair or replace.</p>
<p><b>Insufficient speed change.</b></p>	<p><u>Insufficient motor load</u> – Use a lower horsepower motor. Reduce system restrictions (blower). Increase system restriction (blower fan).</p>
<p><b>Motor overheats while running under load.</b></p>	<p><u>Overload</u> – Reduce load; increase motor size.  <u>Dirt preventing ventilation</u> – Clean motor.  <u>Faulty connection</u> – Clean, tighten or replace.  <u>High or low voltage</u> – Check voltage at motor; should not be more that 10% above or below rated.  <u>Defective motor</u> – Repair or replace.</p>