

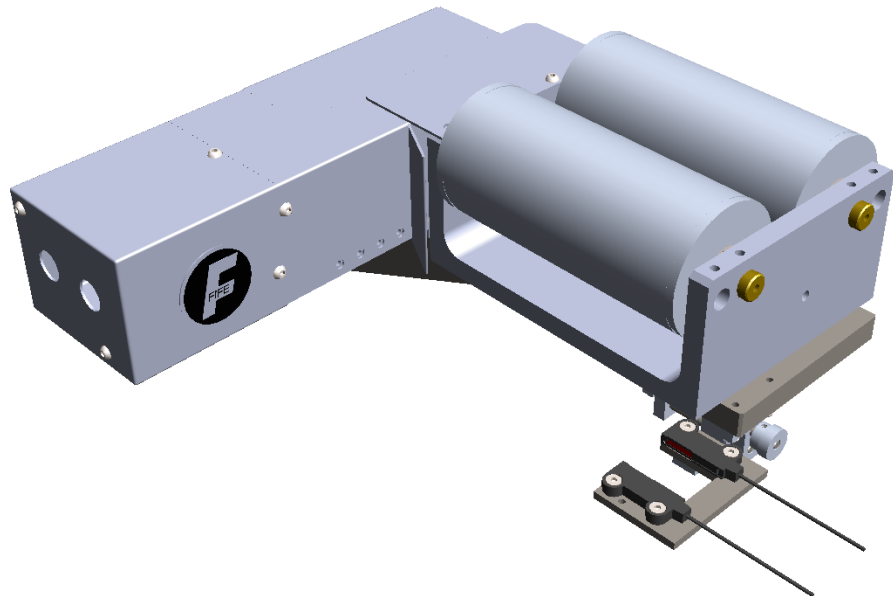

Fife-200 Web Guiding System

Installation and Service Manual



CONTENTS

INTRODUCTION	1-1
About these operating instructions	1-1
CE marking	1-1
Product overview	1-2
SAFETY INSTRUCTIONS	2-1
Instructions for use	2-1
Safety symbols	2-1
Symbols used	2-2
Basic safety information	2-3
INSTALLATION	3-1
Installing the web guide	3-2
Mounting dimensions	3-4
Wrap styles	3-5
Sensor installation.....	3-6
SE-47 sensor	3-6
SE-47 sensor position adjustment.....	3-7
Other Fife sensors	3-7
Installing the operator interface	3-8
Panel mount model.....	3-8
Wall mount model	3-9
Electrical installation	3-10
Installing cables.....	3-10
Controller connection diagrams	3-14
Controller assembly mounting	3-17
Power connection	3-18
Digital inputs/outputs.....	3-19
MAINTENANCE	4-1
MODEL NUMBER KEY	5-1
SPECIFICATIONS	6-1
SERVICE AND REPLACEMENT PARTS	7-1

About these operating instructions

All of the information herein is the exclusive proprietary property of Maxcess International, and is disclosed with the understanding that it will be retained in confidence and will neither be duplicated nor copied in whole or in part nor be used for any purpose other than for which disclosed.

Copyright 2015, all rights reserved.

Periodically there will be updates to this manual. The latest version is available on our website or by calling the number on the back page of this publication.

These web guiding systems must not be installed or used in a machine or system which does not comply with the machinery directive 2006/42/EC.

These web guiding systems were designed and manufactured to be installed as Partly Completed Machinery into a machine or partly completed machine.

The instructions must be read and used by all persons who have the responsibility of installing and maintaining these web guiding systems.

These instructions must be retained and incorporated in the technical documentation for the machine or partly completed machinery into which the web guiding system is installed.

Language

These are the original instructions, written in English.

CE marking

The Fife-200 Web Guiding System complies with the 2006/42/EC Machinery directive and the 2004/108/EC Electromagnetic Compatibility directive.

Conventions used

All dimensions and specifications are shown in the format **mm [inches]** unless otherwise specified.

Product overview

The Fife-200 Web Guiding System is a small web guide and controller that consists of three parts: an offset pivot guide and sensor, a controller capable of controlling four guides and sensors, and an operator interface. The Fife-200 Web Guiding System has an IP40 ingress protection rating. The Fife-200 Web Guiding System is available in four different roll face and guide spans and two different roller diameters.

The Fife-200 Web Guiding System is designed for continuous use. The controller has one sensor input per guide, three parallel inputs per guide, and one parallel output per guide. The controller controls all the guides through the color touch-screen operator interface. The controller parallel inputs and outputs are used for remote control and alarms. The Fife-200 Web Guiding System controls the position of the web by monitoring the web position with the sensor mounted in the web path and driving an actuator connected to the guide assembly to steer the web to the desired position.

The Fife-200 Battery Guiding System is capable of Servo-Center mode without a Servo-Center sensor for centering the guide while threading the web. When entering Servo-Center mode, the guide will jog between the mechanical stops and center at the midpoint of the stops. The Fife-200 Web Guiding System works with most FIFE sensors.

Instructions for use

To ensure safe and problem free installation of the Fife-200 Web Guiding System, it must be properly transported and stored, professionally installed, and placed in operation. Proper operation and maintenance will ensure a long service life of the device. Only persons who are acquainted with the installation, commissioning, operation, and maintenance of the system and who possess the necessary qualifications for their activities may work on the Fife-200 Web Guiding System.

Note: The safety information may not be comprehensive.



Please note the following:

- The content of these operating instructions
- Any safety instructions on the device
- The machine manufacturer's specifications
- All national, state, and local requirements for installation, accident prevention and environmental protection

Safety symbols

Information about safety instructions

The safety instructions and symbols described in this section are used in these operating instructions. They are used to avoid possible dangers for users and to prevent material damage.



SIGNAL WORD

Source of danger and its results
Avoiding dangers

The signal word **DANGER** refers to the danger of death or serious bodily injuries.

The signal word **WARNING** refers to the danger of moderate to severe bodily injuries.

The signal word **CAUTION** refers to the danger of slight to moderate bodily injuries or material damage.

The signal word **NOTICE** refers to the possibility of damage to equipment.

Symbols used

The following safety identification symbols are used in these operating instructions.



WARNING/CAUTION – General danger or important note
Reference to general hazards that may result in bodily injuries or damage to device or material.



WARNING/CAUTION – Danger due to crushing
Reference to danger of injury caused by crushing.



WARNING/CAUTION – Danger due to cutting
Reference to danger of injury caused by cutting.



WARNING/CAUTION – Danger due to voltage, electric shock
Reference to danger of injury caused by electric shock due to voltage.



WARNING/CAUTION – Danger due to hot surfaces
Reference to risk of injury caused by burning.

Basic safety information

Proper use

The Fife-200 Web Guiding System is intended to be used on machines or systems to guide a web of material.

Indoor operation: see environmental specifications

Improper use

Operation outside the technical specifications

Operation in an Ex-area or intrinsically safe area

Operation as a safety component. The Fife-200 Web Guiding System does not hold the web position if power fails.

Outdoor operation

Any other use than the proper use shall be deemed inappropriate.

Installation and commissioning

Any Fife-200 Web Guiding System which is damaged must not be installed or put into operation.

Only perform installation, maintenance or repair tasks on the Fife-200 Web Guiding System when the machine has been stopped and is secured from being turned on.

Only perform installation, maintenance or repair tasks on the Fife-200 Web Guiding System when there is no electrical power in the system.

The Fife-200 Web Guiding System must be securely mounted before being placed in operation.

Only replacement parts obtained from Fife may be used.

No modifications may be made to the Fife-200 Web Guiding System.

Do not place electrical cables under mechanical strain.



WARNING - Death or injury can result from static electric shocks. Moving webs of material can produce large static voltage potentials. Protect against electric shocks by installing a conductive connection between the power cable GREEN wire and the PE circuit of the building or machine.



WARNING - The Fife-200 Web Guiding System contains rotating and moving parts which could cause injury due to crushing. Appropriate protective guards must be installed by the user according to his use of this product.



WARNING – Death or injury can result from unexpected movement.

Protect against unexpected movement by removing electrical power from the Fife-200 Web Guiding System and the machine into which it is being installed.

Operation



WARNING – The Fife-200 Web Guiding System contains rotating and moving parts which could cause injury due to crushing. Do not touch anything on or in the vicinity of the moving or rotating parts. Appropriate protective guards must be installed by the user according to his use of this product.

Maintenance and repair



WARNING – Death or injury can result from unexpected movement.

Protect against unexpected movement by removing electrical power from the Fife-200 Web Guiding System and the machine into which it is installed.



WARNING – Danger of injury from crushing.

Maintenance and repair tasks on the Fife-200 Web Guiding System must be performed only when the machine has been stopped and has been secured from being turned on again.

Decommissioning

The Fife-200 Web Guiding System must be disposed of in accordance with all the applicable national, state and local regulations.

Electrical and mechanical installation



CAUTION - Never place electrical cables under mechanical strain. Always provide mechanical support of wiring with either clamps or flexible or rigid conduit.



WARNING - Death or injury can result from unexpected movement.

Protect against unexpected movement by removing electrical power from the Fife-200 Web Guiding System and the machine into which the Fife-200 Web Guiding System is installed.



WARNING - Danger of injury from crushing.

Maintenance and repair tasks on the Fife-200 Web Guiding System must be performed only when the machine has been stopped and has been secured from being turned on again.



WARNING - The Fife-200 Web Guiding System contains rotating and moving parts which could cause injury due to crushing. Appropriate protective guards must be installed by the user according to his use of this product.

Installing the web guide

Mount the guide(s) in the web path on a rigid support frame using four M8 bolts through the 9 mm [0.35 in] diameter holes in the guide support frame.

Inside type (actuator is between mounting surface and guide)

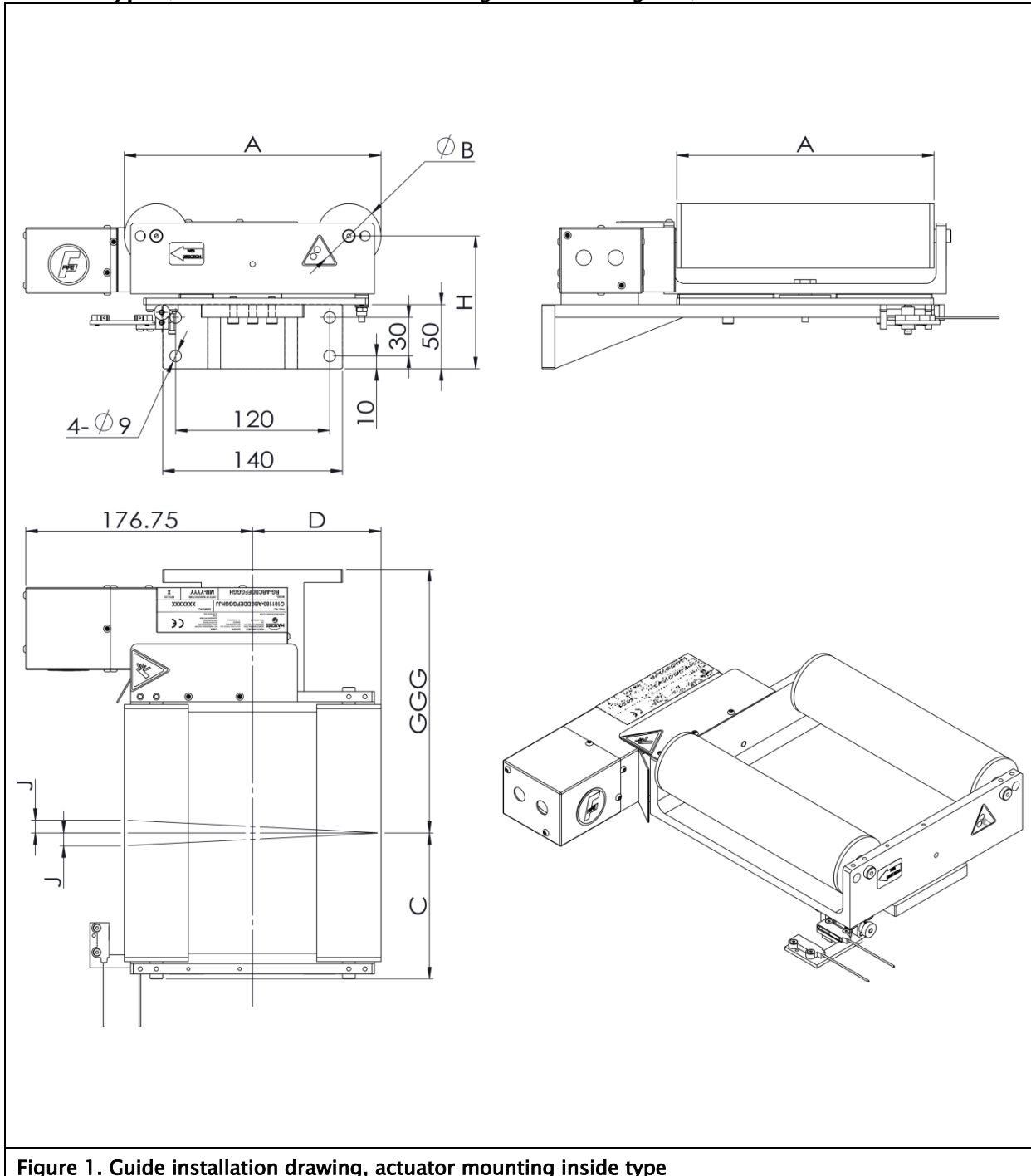

Outside type (actuator is NOT between mounting surface and guide)

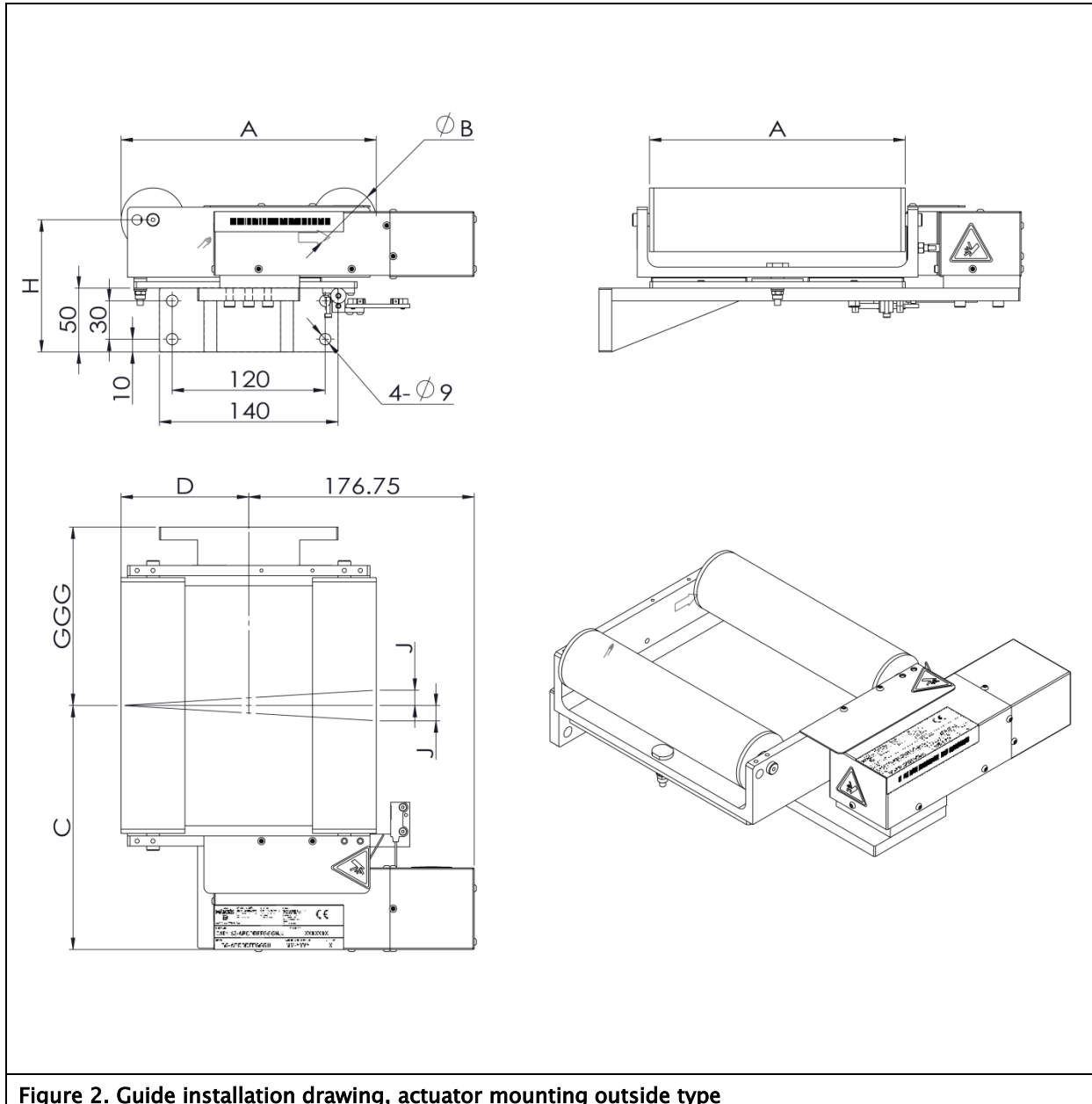

Mounting dimensions

Refer to Figure 1 for references to dimensions for the Actuator Mounting, Inside Type.

Roll Face and Guide Span A	Roll Diameter B	D	Maximum Correction J	Maximum Tension T	Correction Speed S	Height H	C	Guide Center Distance GGG
60 [2.362]	25 [0.984]	30 [1.181]	+/-10 [+/-0.394]	49 N [11 lb]	61 mm/s [2.402 in/s]	78.5 [3.091]	56 [2.205]	125 to 350 [4.921 to 13.780]
110 [4.331]	25 [0.984]	48.5 [1.909]	+/-12 [+/-0.472]		67 mm/s [2.638 in/s]	98.5 [3.878]	77.5 [3.051]	160 to 350 [6.299 to 13.780]
	50 [1.969]				76 mm/s [2.992 in/s]	103.5 [4.075]	85 [3.346]	175 to 350 [6.890 to 13.780]
140 [5.512]	25 [0.984]	61.5 [2.421]			81 mm/s [3.189 in/s]	103.5 [4.075]	113.5 [4.469]	205 to 350 [8.071 to 13.780]
	50 [1.969]							
200 [7.874]	25 [0.984]	100 [3.937]						
	50 [1.969]							

Table 1. Dimensions for actuator mounting inside.

Refer to Figure 2 for references to dimensions for the Actuator Mounting, Outside Type.

Roll Face and Guide Span A	Roll Diameter B	D	Maximum Correction J	Maximum Tension T	Correction Speed S	Height H	C	Guide Center Distance GGG
60 [2.362]	25 [0.984]	30 [1.181]	+/-10 [+/-0.394]	49 N [11 lb]	61 mm/s [2.402 in/s]	78.5 [3.091]	134 [5.276]	125 to 300 [4.921 to 11.811]
110 [4.331]	25 [0.984]	48.5 [1.909]	+/-12 [+/-0.472]		67 mm/s [2.638 in/s]	98.5 [3.878]	155.5 [6.122]	125 to 300 [4.921 to 11.811]
	50 [1.969]				76 mm/s [2.992 in/s]	103.5 [4.075]	163 [6.417]	125 to 300 [4.921 to 11.811]
140 [5.512]	25 [0.984]	61.5 [2.421]			81 mm/s [3.189 in/s]	103.5 [4.075]	191.5 [7.539]	135 to 300 [5.315 to 11.811]
	50 [1.969]							
200 [7.874]	25 [0.984]	100 [3.937]						
	50 [1.969]							

Table 2. Dimensions for actuator mounting outside.

Wrap styles

Allowed wrap styles

Mount the guide and thread the web using one of the allowed wrap styles, indicated by a checkmark in Figure 3.

1	✓		9		✓
2			10		
3	✓		11		✓
4			12		
5			13		
6			14		
7			15		
8			16		

Figure 3. Allowed wrap styles

Sensor Installation

SE-47 sensor

This section only applies when using the SE-47 sensor.

1. Mount the SE-47 amplifier in a convenient location near the guide on a small piece of 35 mm DIN rail.
2. Using the supplied cutting tool, trim the fiber optic cable from the sensor head to a length needed to reach the amplifier.
3. Loosen the holders and position the fibers for the length that needs to be cut.
4. Tighten the holders to secure the fibers in the gland. Lift the handle on the cutting tool.
5. Insert the gland into the cutting tool as shown in Figure 4.
6. Press down firmly on the cutting tool handle to cut off excess length of fiber.
7. After the fibers are cut to length, open the fiber locking latch on the amplifier as shown by moving to position (A) in Figure 5.
8. Install the fibers into the fiber ports on the amplifier. Move the fiber locking latch to position (B) to lock the fibers in place.

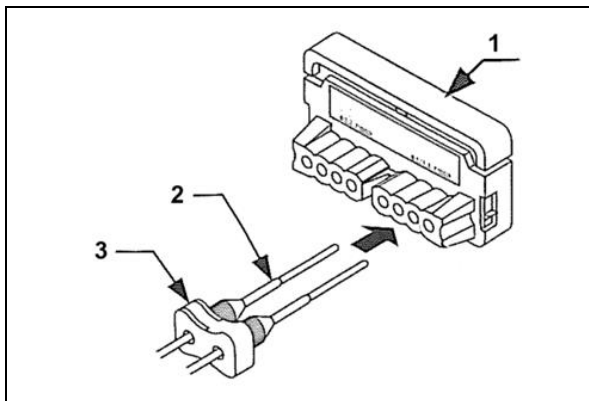

- | | |
|---|--------------------|
| 1 | Fiber cutting tool |
| 2 | Holder |
| 3 | Gland |

Figure 4. Inserting fibers in cutting tool.

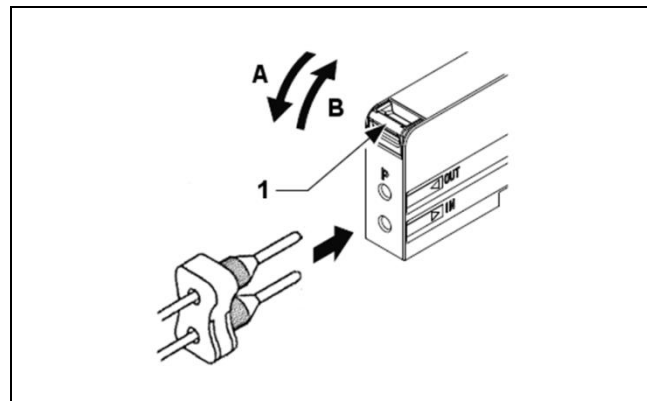

- | | |
|---|---------------------|
| 1 | Fiber locking latch |
| A | Open |
| B | Locked |

Figure 5. Installing fibers into SE-47 amplifier.

►► See next page for sensor position adjustment.

SE-47 sensor position adjustment

Adjust the position of the SE-47 sensor heads, by loosening set screw **(B)** and turning the adjustment knob **(A)**.

Once the sensor heads are in the desired location, tighten the set screw to prevent the sensor heads from moving.

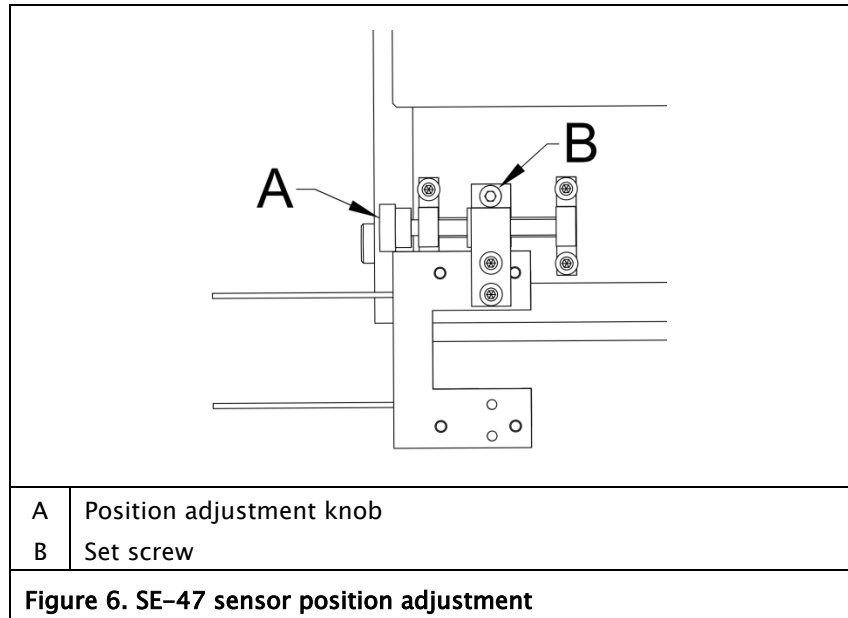

Other Fife sensor installation

This section only applies when using other standard Fife sensors, including the SE-11, SE-22, SE-44R, SE-31, and SE-26A.

Mount the sensors in the web path on a customer-supplied support frame.

Installing the operator interface

The operator interface can be mounted in a panel or on a wall.

Installation kits

Description	Part Number
OI-FB Panel Mounting Kit	215802-001
OI-FB Wall Mounting Kit	216873-001

Panel mount model



CAUTION - Never place electrical cables under mechanical strain. Always provide mechanical support of wiring with either clamps or flexible or rigid conduit.

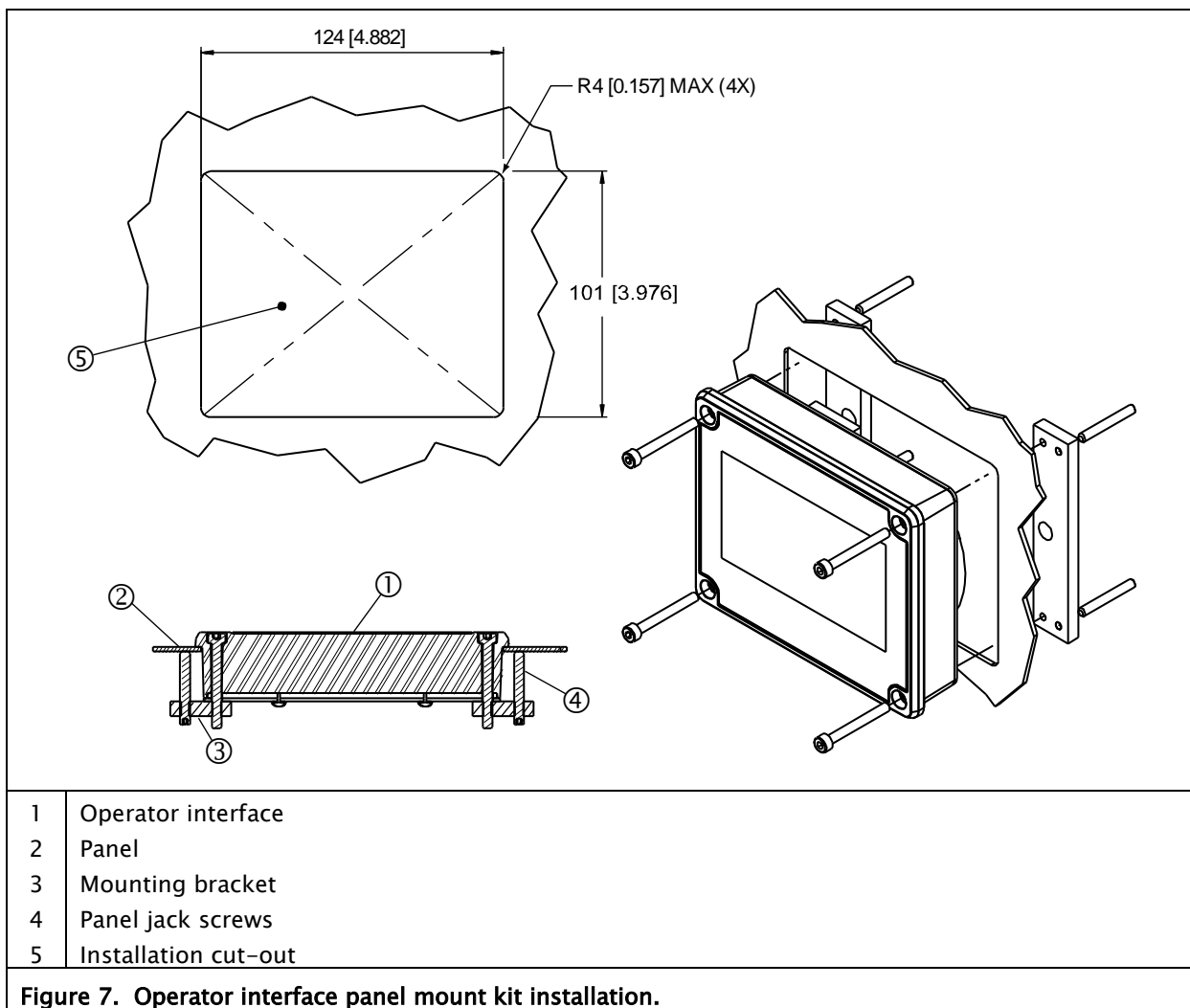

Wall mount model



CAUTION - Never place electrical cables under mechanical strain. Always provide mechanical support of wiring with either clamps or flexible or rigid conduit.

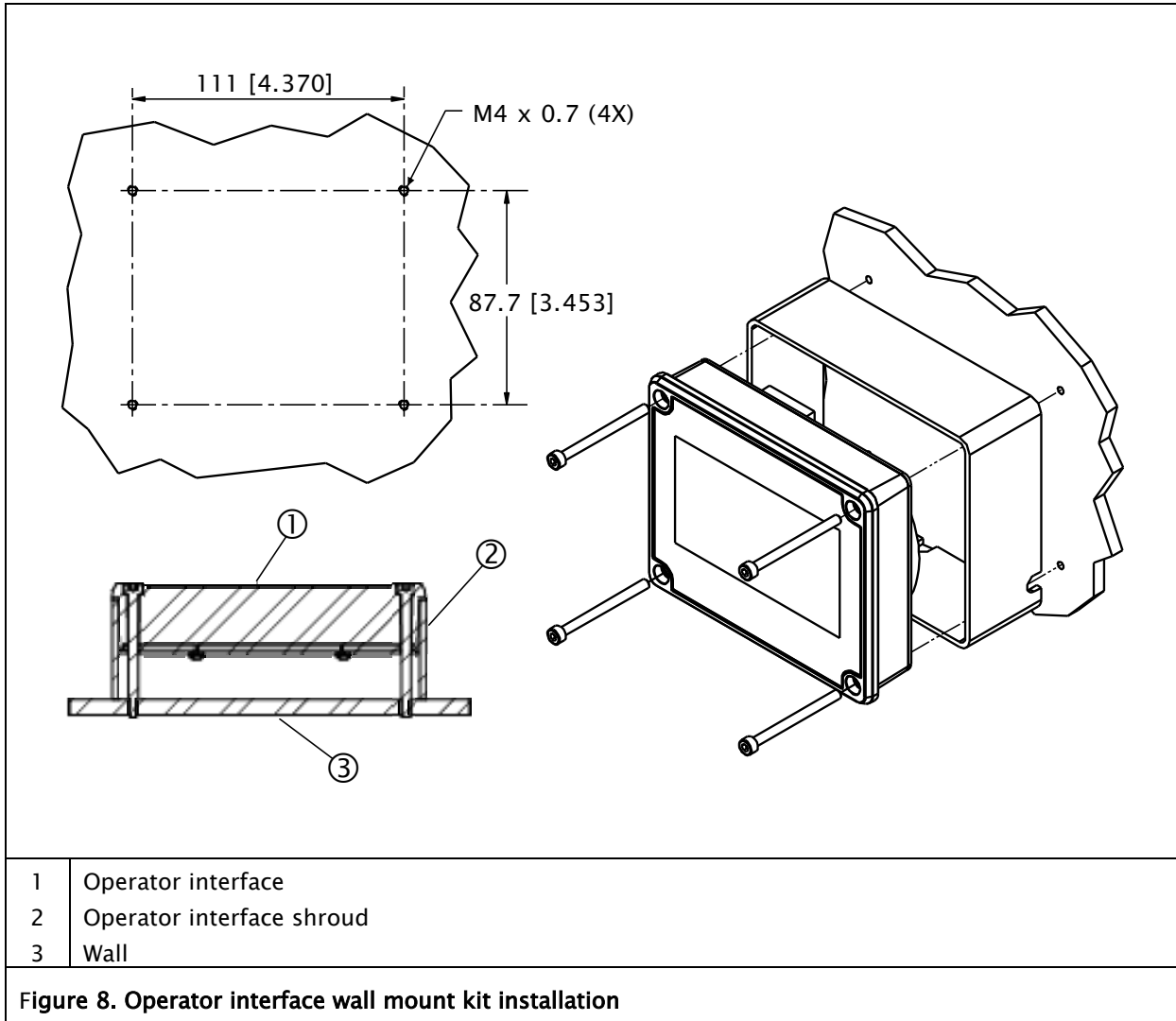

Figure 8. Operator interface wall mount kit installation

Controller installation

Installing cables in the controller housing

OI, motor, sensor, and parallel I/O cables

Figure 9 shows the system connection overview for sensor types SE-47, SE-11, SE-22, SE-44R, and SE-31. Sensor 1 should be sensing the web on Guide 1. The same is true for the other guides and sensors.

The controller can control four guides; however, when using the SE-26A sensor it will only control two guides. See Figure 10 on next page.

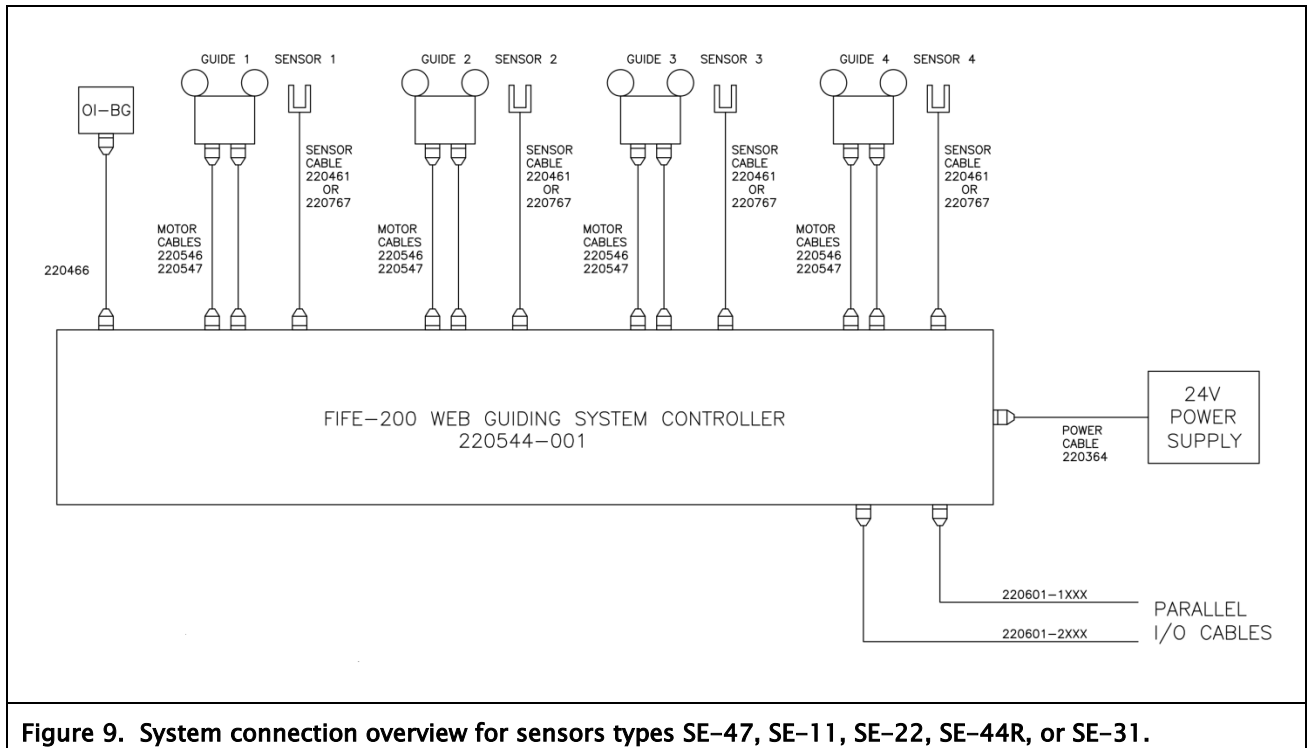

Figure 9. System connection overview for sensors types SE-47, SE-11, SE-22, SE-44R, or SE-31.

Installing cables (continued)

Figure 10 shows the system connection overview for sensor type SE-26A.

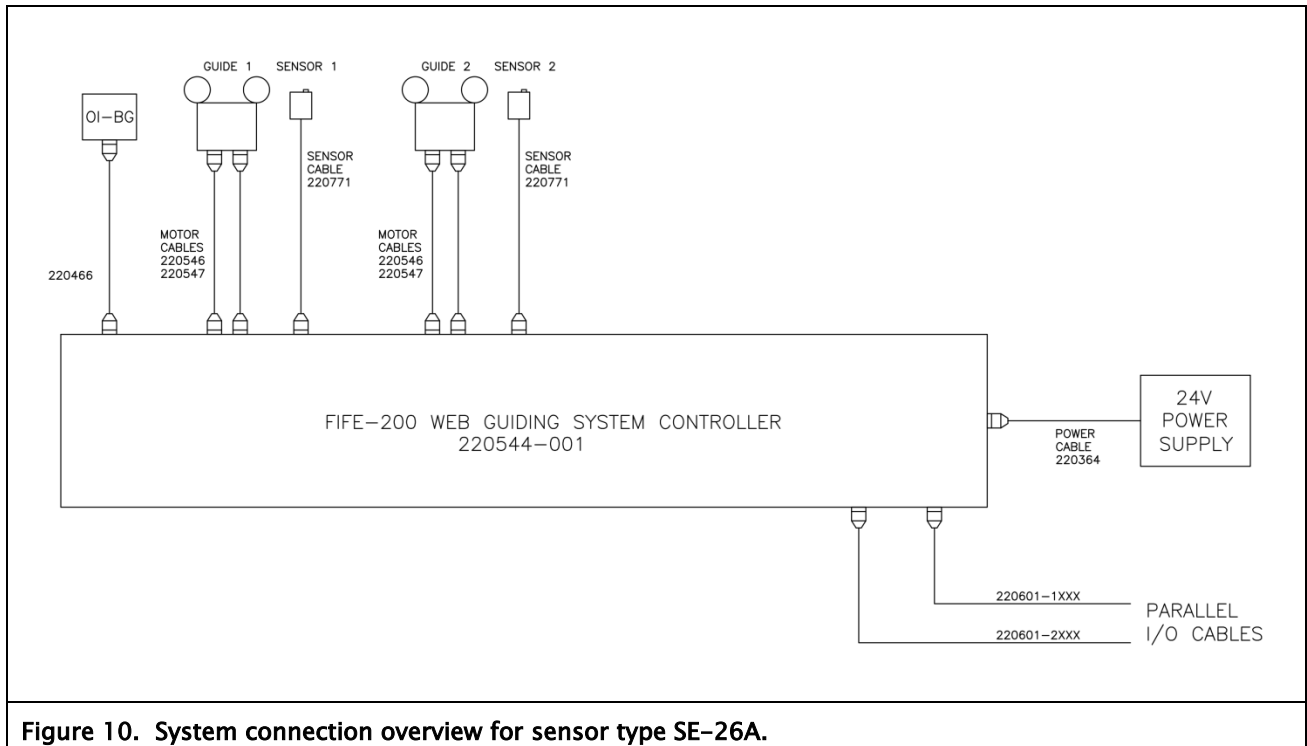
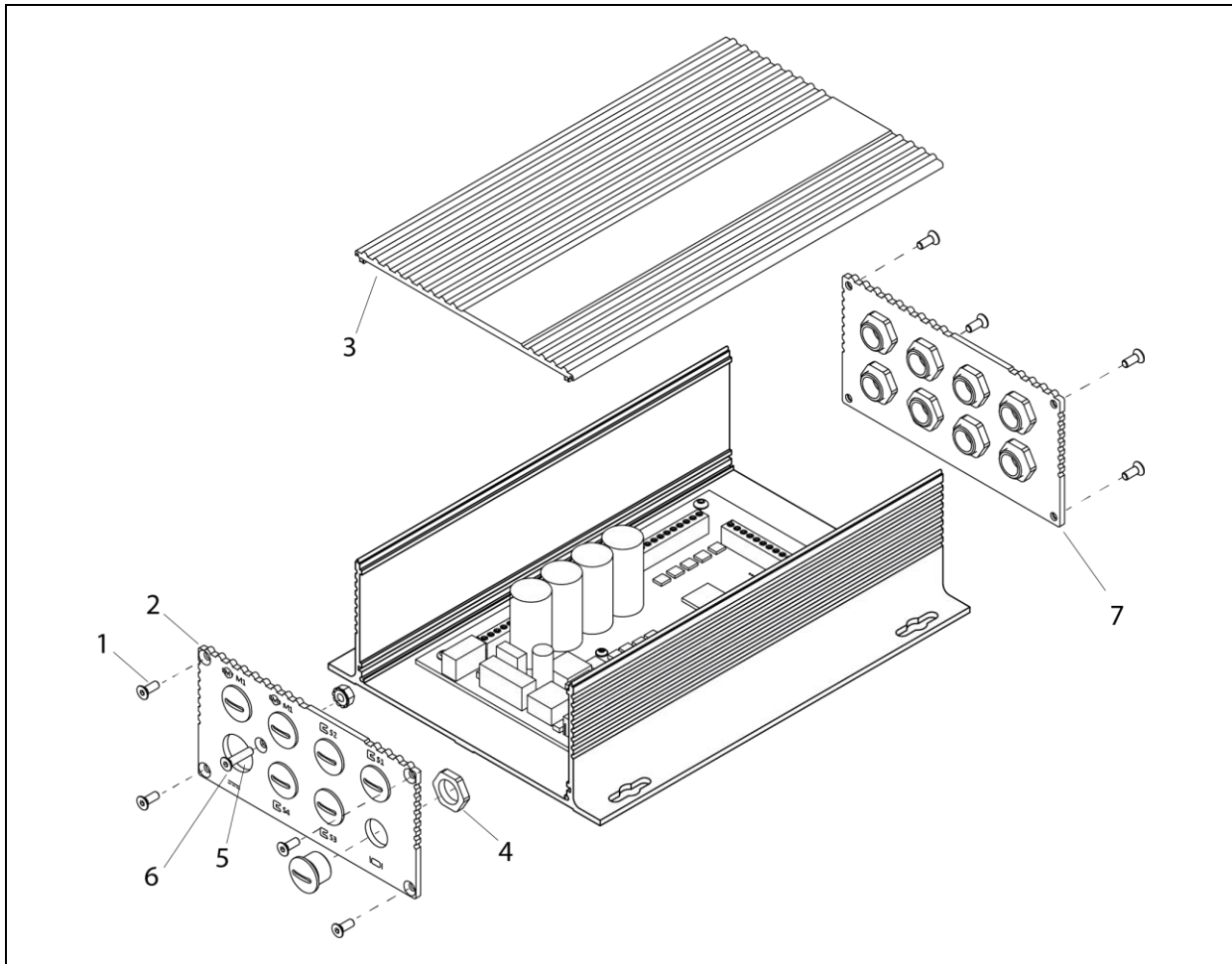

Figure 10. System connection overview for sensor type SE-26A.

Installing cables

(continued)

1. Remove the eight screws that secure the controller end plates.
2. Remove the controller cover by pulling up on one side.



- | | |
|---|--|
| 1 | M3 flat head screw (8 ea) |
| 2 | End plate, power entry |
| 3 | Controller cover |
| 4 | Lock nut for sensor cable bushing |
| 5 | Power supply cable opening |
| 6 | Flat head screw and nut for ground wire connection |
| 7 | End plate, parallel I/O entry |

Figure 11. Controller cable installation components.

continued

Installing cables

(continued)

3. You will need to remove hole plugs from the end plates to connect the cables. Use the controller connection diagrams and the markings on the end plates to determine which hole plugs to remove.
4. Re-use the lock nuts to install the bushings from the cables in the appropriately marked holes in each of the end plates.

The lock nut for the power cable bushing is on the bushing.

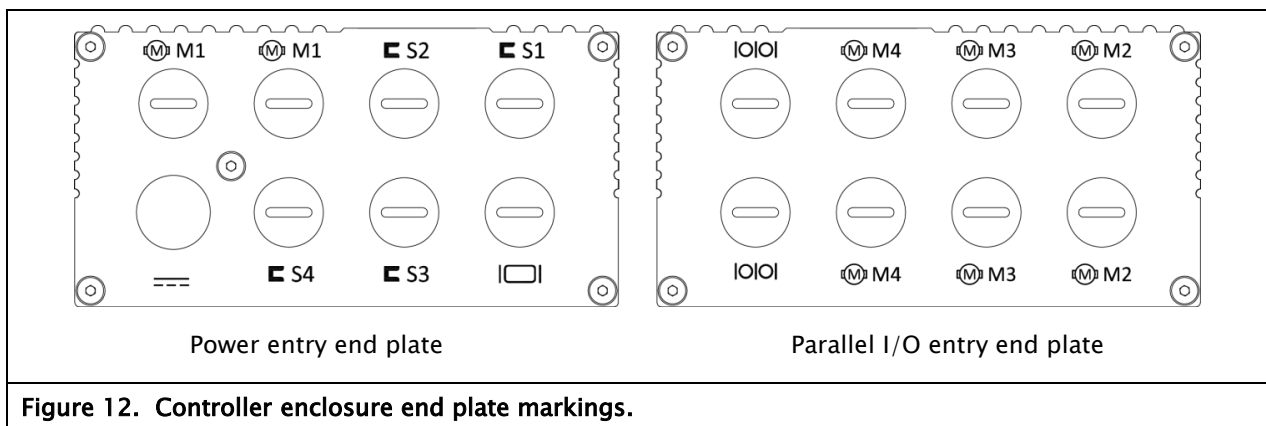

Figure 12. Controller enclosure end plate markings.

Connecting earth ground (PE)

The green wire with the ring terminal from the power cable is the protective earth connection and is labeled "PE".

It must be connected to the inside of the power entry end plate and secured with the supplied flat head screw and nut.

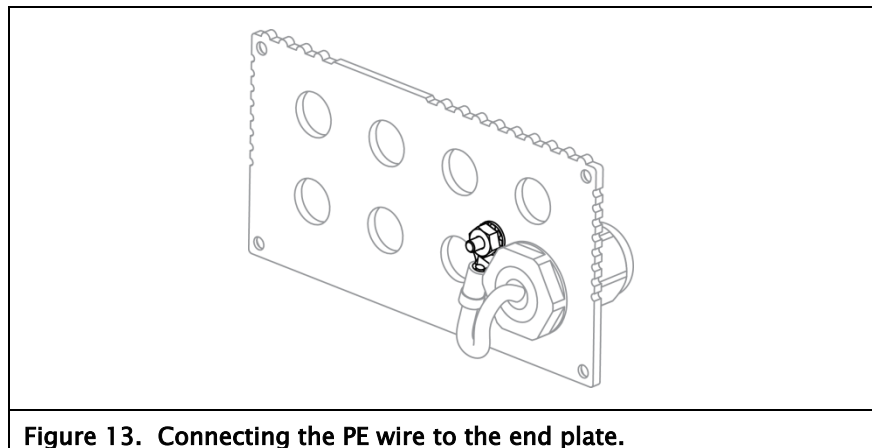

Figure 13. Connecting the PE wire to the end plate.

Controller connection diagrams



WARNING – Death or injury can result from static electric shocks.

Moving webs of material can produce large static voltage potentials. Protect against electric shocks by ensuring a conductive connection between the power cable GREEN wire and the inside of the enclosure end plate.

- Connect the wires from each cable to the appropriate terminal block pins as shown in the connection diagram in Figure 14 or Figure 15 on the following pages.
- The power, motor, and OI cable wires are marked with the terminal block pin numbers.
- The sensor cable wires are not marked with the terminal block pin numbers.
- Each cable is marked with a part number and the cable part number is shown in Figure 14 or Figure 15.
- Figure 14 shows the connections for the motor and the sensors SE-47, SE-11, SE-22, SE-44R, and SE-31.
- Figure 15 shows the motor and sensor connections for the SE-26A (Line Sensor).
- When using the SE-26A (Line Sensor) only two guides can be controlled — Guides 1 and 2.
- Refer to drawing 220712 for a complete list of cables.

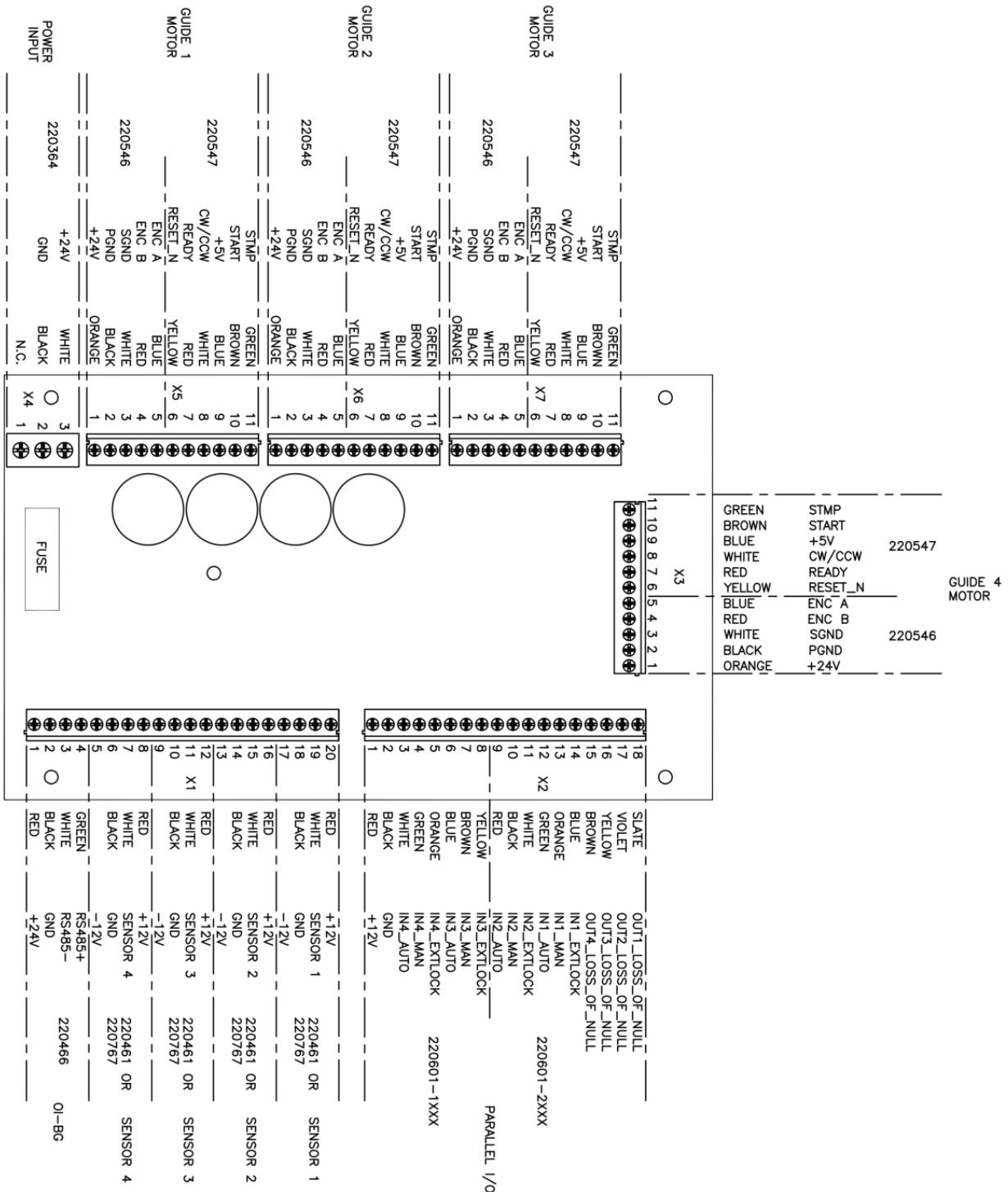

Figure 14. Controller connections for guides and sensor types SE-47, SE-11, SE-22, SE-44R, or SE-31.

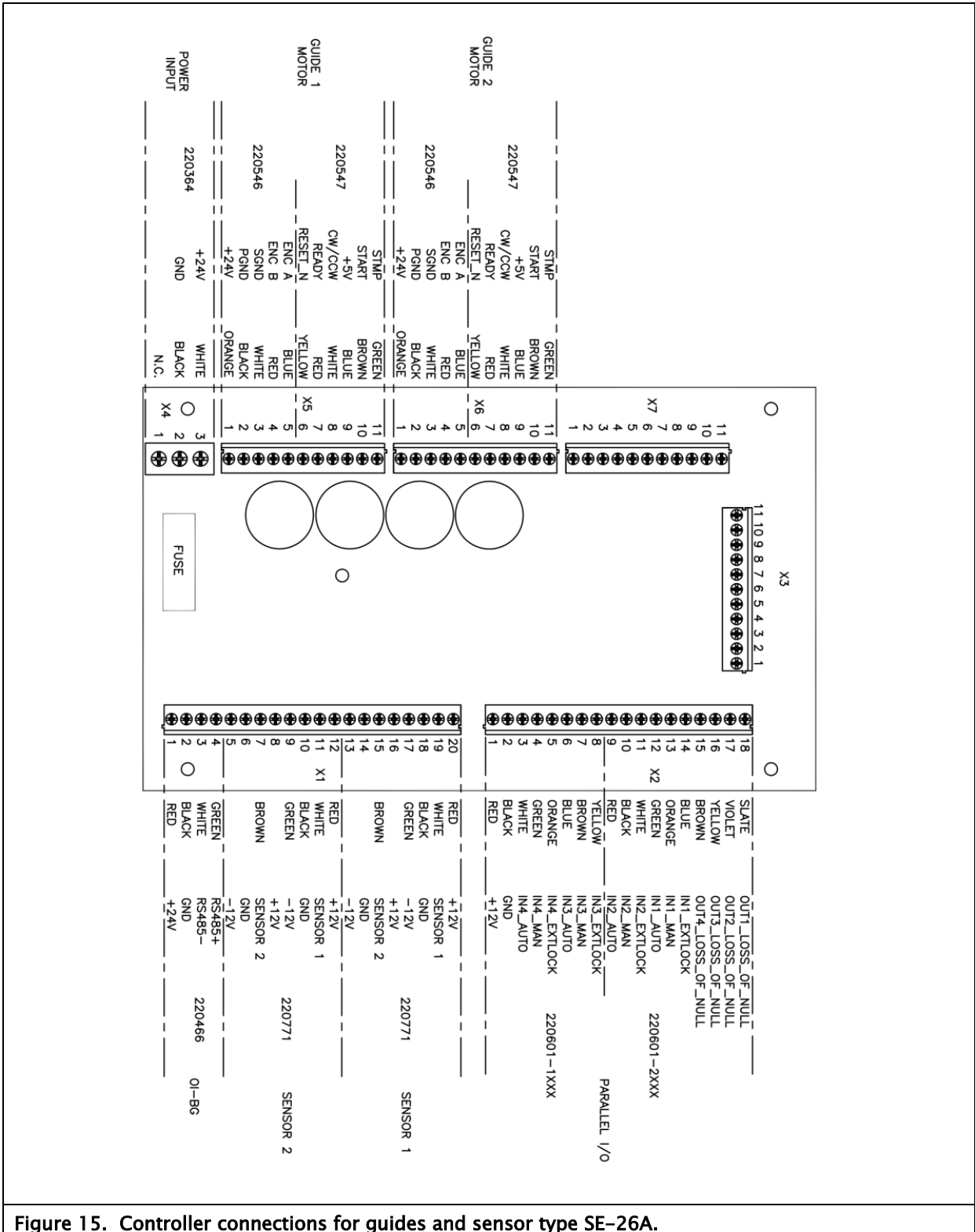
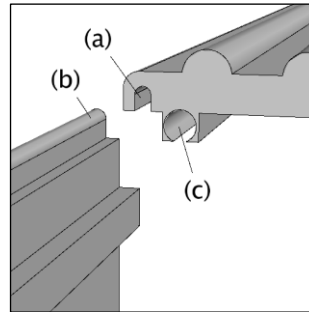

Figure 15. Controller connections for guides and sensor type SE-26A.

Controller assembly mounting

Reassemble the controller enclosure

1. Re-install the controller housing cover by sliding it onto the controller housing base. Make sure that the outside groove (a) on the housing cover aligns with the top edge of the base (b). The threaded opening (c) is for the screws that secure the end plates to the assembly.



2. Attach the end plates to the controller housing base and secure with the eight M3 flat head screws.
3. Mount the assembled controller to a rigid frame with four M6 bolts in the controller mounting holes shown in Figure 16.

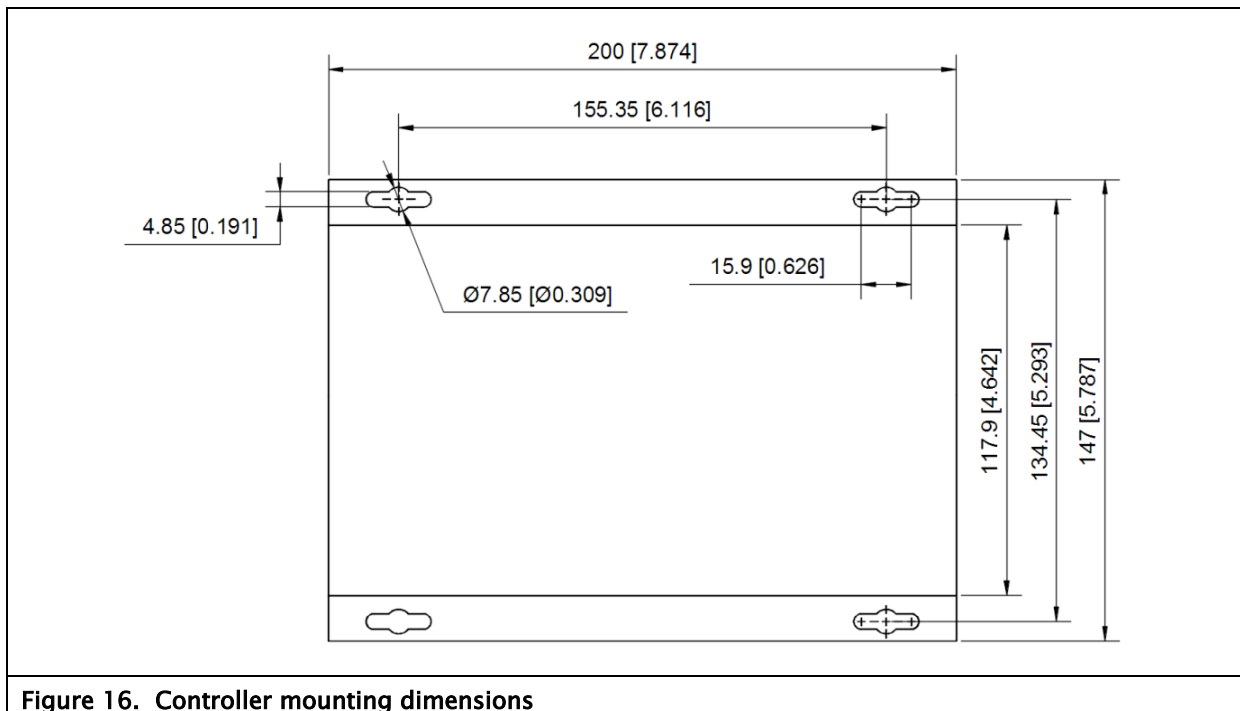

Power connection

Operating voltage range and current rating are listed in Specifications (page 6-1) and shown on the label on the controller housing.

All wiring must comply with the essential requirements of the appropriate standard(s) and is the responsibility of the installer.

Wiring to the Fife-200 Web Guiding System must be insulated copper wire with a temperature rating of at least 80°C. The wire size should be 0.82 mm² (18 AWG).

1. Connect a 24 VDC +10%/-6% power supply to the power cable. The WHITE wire is positive and the BLACK wire is negative.
2. Connect the PE of the building or machine to the power cable GREEN wire.

NOTE: The negative power connection (BLACK wire) is internally connected to the PE connection (GREEN wire). This connection is used for EMC compliance.



WARNING – Death or injury can result from static electric shocks.

Moving webs of material can produce large static voltage potentials. Protect against electric shocks by installing a conductive connection between the power cable GREEN wire and the PE circuit of the building or machine.



CAUTION – Never place electrical cables under mechanical strain. Always provide mechanical support of wiring with either clamps or flexible or rigid conduit.

Digital inputs/outputs

There are three digital inputs and one output available per guide for remote control and signaling functions. The digital inputs allow control of the following modes for each guide: External Lock, Automatic and Manual. The digital output is initially configured as an alarm for Loss of Null for each guide. See Table 3 and Table 4 for the default configurations.

Refer to Figure 14 and Figure 15 for the controller connections and the parallel I/O cable drawing 220601.

Note: To ensure that a command is properly executed, all pertinent inputs for each command must be switched high or low within 20 ms of each other and maintained for at least 30 ms.

Table 3. Digital input matrix default configuration for each guide.

0 = LOW
1 = HIGH
- = IGNORE

MODE	INPUTS		
	2	1	0
EXTERNAL LOCK	-	-	1
MANUAL	-	1	-
AUTO	1	-	-



WARNING - Death or injury can result from unexpected movement.

Switching to Auto mode can cause unexpected movement of the guide.

Table 4. Digital output matrix default configuration for each guide.

1 = ACTIVE
- = IGNORE

STATUS	OUTPUT*
LOSS OF NULL (AUTOMATIC MODE)	1

* Digital outputs are active low

Maintenance



WARNING – Death or injury can result from unexpected movement.

Protect against unexpected movement by removing electrical power from the Fife-200 Web Guiding System and the machine into which the Fife-200 Web Guiding System is installed.



WARNING – Danger of injury from crushing.

Maintenance and repair tasks on the Fife-200 Web Guiding System must be performed only when the machine has been stopped and has been secured from being turned on again.



WARNING – To prevent death or injury, always use standard Lockout/Tagout procedures.

- Maintenance schedules are recommended intervals only. Ambient conditions can influence intervals considerably. Therefore, adjustments to the recommendations must be made accordingly.
- The motor of the Fife-200 guide requires no maintenance.
- Sensors shall be cleaned as necessary in order to ensure lenses, transmitters, and/or receivers have a clear path to detect the web. Cleaning shall consist of wiping down components as necessary with a clean and dry cloth.
- Operator Interface (touchscreen) should be cleaned as necessary in order to ensure clear visibility of the menus. Cleaning shall consist of wiping down components as necessary with a clean and dry cloth. Commercial liquid cleaner may be used if necessary, but ensure that a small amount of liquid is placed on the cloth before wiping down the screen. Do not directly spray the screen. Compressed air or a shop vacuum may also be used as necessary.

Model number key

Fife-200 Web Guiding Controller

Model number: FB-C

Part number: 220544-001

Fife-200 Web Guiding Operator Interface

Model number: OI-FB

Part number: 220490-xxx

xxx specifies the length of the cable in 0.1 meter increments.

Fife-200 Web Guiding Web Guide

Model number: FB-abcdefgggh

Part number: C101183-abcdefggghjj

abcdefgggh specifies the mechanical attributes of each guide.

jj specifies the length of the motor and sensor cables in 0.1 meter increments.

a = Guide size (roll face x guide span)

1 = 60 x 60 [2.36 x 2.36]

2 = 110 x 110 [4.33 x 4.33]

3 = 140 x 140 [5.51 x 5.51]

4 = 200 x 200 [7.87 x 7.87]

b = Roller diameter

0 = No rollers

1 = 25 [0.98]

2 = 50 [1.96]

c = Roller coatings

0 = No rollers

1 = Standard

2 = Hard coat anodize

3 = Dragon Elite II plasma coat

4 = Rubber cork tape

5 = 11036 plasma coat

dd = Sensor type

00 = None

01 = SE-47

XX = Other standard Fife sensors

continued

Model number key

(continued)

- e = Sensor bracket
 - 0 = None
 - 1 = Standard
 - 2 = Fine adjustment

- f = Guide direction
 - 1 = Left to right
 - 2 = Right to left

- ggg = Guide center distance in millimeters
(125 to 350 currently)

- h = Actuator mounting type
 - 1 = Actuator mounting between wall and guide
 - 2 = Actuator mounting outside the guide

- jj = Motor and sensor cable length in 0.1 meter increments.

General specifications

- Operating temperature - 0° to 50° C [32° to 122° F]
- Ingress protection class - IP40
- RoHS - Compliant

Maximum cable lengths

- Power cable - 5 m [16.4 ft]
- Motor cable - 5 m [16.4 ft]
- Sensors - 5 m [16.4 ft]
- Digital input/output port - 10 m [32.8 ft]
- Operator interface - 20 m [65.6 ft]

Guide specifications

- Maximum web tension - 49 N [11 lbs]
- Correction speed -

60 x 60	61 mm/s [2.4 in/s]
110 x 110	67 mm/s [2.6 in/s]
140 x 140	76 mm/s [3.0 in/s]
200 x 200	81 mm/s [3.2 in/s]
- Correction range - +/- 12 mm [0.47 in]
+/- 10 mm [0.39 in] for 60x60 guide
- Dimensions - See Figure 1, Figure 2, Table 1, and Table 2
- Weight -

60 x 60	2.5 kg [5.5 lb]
110 x 110	3.6 kg [8.0 lb]
140 x 140	4.4 kg [9.8 lb]
200 x 200	5.7 kg [12.65 lb]
- Motor - 24 VDC brushless

Controller specifications

- Input voltage range - 22.5 to 26.4 VDC
Proper earth grounding is required.
Note that the negative supply and housing ground are interconnected.
The power supply must have an SELV output, such as Puls CS10.241-S1, or equivalent.
- Supply current - 5 A maximum
- Internal fuse - 10 A, slow-blow

Dimensions

- Controller - Height - 62 mm [2.44 in]
Width - 147 mm [5.79 in]
Length - 260 mm [10.24 in]

- Product certifications - CE
TUV Rheinland of North America to UL61010-1
and
CAN/CSA-C22.2 No. 61010-1 and
CB Certificate to IEC61010-1

Inputs and outputs

- Number of guides controlled - Four (two when using SE-26A)
- Sensor input (four) - One per guide
Max input +/-20 mA
Individually programmable
0 to 10 mA (preferred)
- Digital port - 12 digital inputs, three per guide
Active high
Low level: 0 to 0.9 V
High level 3.5 to 24 V

Four outputs, one per guide
Open collector
55 mA at 1.6V saturation
Maximum +30 VDC applied to output
+12 V available to port for input reference
- Supply to accessories - +12 V +/-5%, 600 mA maximum
-12 V +/-5%, 80 mA maximum

Service requests and replacement parts

To request service or to get replacement parts, contact one of the following addresses:

Maxcess Oklahoma

222 West Memorial Rd.
Oklahoma City, OK, 73114, USA
Tel +1.405.755.1600
Fax +1.405.755.8425
www.maxcessintl.com

Maxcess Europe

Max-Planck-Strasse 8
65779 Kelkheim
Deutschland
Tel +49.6195.7002.0
Fax +49.6195.7002.933
www.maxcess.eu

Maxcess (Zhuhai) Industrial Automation Equipment Co., Ltd.

#7 Warehousing Factory
Hengli Industrial Park
#5 Land of Zhuhai
Free Trade Zone
Guangdong PR 519030
China
Tel +86.756.881.9398



When ordering replacement parts, please indicate, where possible, part number, drawing number and model description.

If it is necessary to return the Fife-200 Web Guiding System for service, care must be taken to properly package the unit to prevent damage during shipment. If possible, use the original shipping containers.



**NORTH, CENTRAL
AND SOUTH AMERICA**

Tel +1.405.755.1600
Fax +1.405.755.8425
sales@maxcessintl.com
www.maxcessintl.com

INDIA

Tel +91.22.27602633
Fax +91.22.27602634
india@maxcessintl.com
www.maxcess.in

**EUROPE, MIDDLE EAST
AND AFRICA**

Tel +49.6195.7002.0
Fax +49.6195.7002.933
sales@maxcess.eu
www.maxcess.eu

JAPAN

Tel +81.43.421.1622
Fax +81.43.421.2895
japan@maxcessintl.com
www.maxcess.jp

CHINA

Tel +86.756.881.9398
Fax +86.756.881.9393
info@maxcessintl.com.cn
www.maxcessintl.com.cn

**KOREA, TAIWAN,
AND SE ASIA**

Tel +65.9620.3883
Fax +65.6235.4818
asia@maxcessintl.com