



Service Manual

Sand Pro & Infield Pro 3040/5040

Preface

The purpose of this publication is to provide the service technician with information for troubleshooting, testing and repair of major systems and components on the Sand Pro and Infield Pro 3040/5040.

REFER TO THE OPERATOR'S MANUALS FOR OPERATING, MAINTENANCE AND ADJUSTMENT INSTRUCTIONS. Space is provided in Chapter 2 of this book to insert the Operator's Manuals and Parts Catalogs for your machine. Replacement Operator's Manuals are available on the internet at www.toro.com or by sending complete Model and Serial Number to:

The Toro Company
Attn. Technical Publications
8111 Lyndale Avenue South
Minneapolis, MN 55420

The Toro Company reserves the right to change product specifications or this publication without notice.



This safety symbol means DANGER, WARNING, or CAUTION, PERSONAL SAFETY INSTRUCTION. When you see this symbol, carefully read the instructions that follow. Failure to obey the instructions may result in personal injury.

NOTE: A **NOTE** will give general information about the correct operation, maintenance, service, testing or repair of the machine.

IMPORTANT: The **IMPORTANT** notice will give important instructions which must be followed to prevent damage to systems or components on the machine.



This page is intentionally blank.

Table Of Contents

Chapter 1 – Safety

Safety Instructions	1 – 2
Jacking Instructions	1 – 4
Safety and Instruction Decals	1 – 4

Chapter 2 – Product Records and Maintenance

Product Records	2 – 1
Maintenance	2 – 1
Equivalents and Conversions	2 – 2
Torque Specifications	2 – 3

Chapter 3 – Gasoline Engine

Introduction	3 – 2
Specifications	3 – 3
General Information	3 – 4
Service and Repairs	3 – 5
BRIGGS & STRATTON REPAIR MANUAL FOR 4-CYCLE, V-TWIN CYLINDER, OHV HEAD ENGI- NES	

Chapter 4 – Hydraulic System

Specifications	4 – 2
General Information	4 – 3
Hydraulic Schematics	4 – 6
Hydraulic Flow Diagrams	4 – 10
Special Tools	4 – 16
Troubleshooting	4 – 19
Testing	4 – 21
Service and Repairs	4 – 34
PARKER TORQMOTOR™ SERVICE PROCEDURE (TC, TB, TE, TJ, TF, TG, TH AND TL SERIES)	
SAUER-DANFOSS (SUNDSTRAND) 15 SERIES RE- PAIR MANUAL	
SAUER-DANFOSS (SUNDSTRAND) 15 SERIES SERVICE MANUAL	
SAUER-DANFOSS STEERING UNIT TYPE OSPM SERVICE MANUAL	

Chapter 5 – Electrical System

Electrical Schematic and Drawings	5 – 2
Special Tools	5 – 2
Troubleshooting	5 – 4
Electrical System Quick Checks	5 – 7
Component Testing	5 – 8
Service and Repairs	5 – 14

Chapter 6 – Chassis

Specifications	6 – 2
Special Tools	6 – 3
Service and Repairs	6 – 4

Chapter 7 – Electrical Diagrams

Electrical Schematic	7 – 3
Circuit Diagrams	7 – 4
Wire Harness Drawings	7 – 6

Safety

Product Records
and Maintenance

Gasoline
Engine

Hydraulic
System

Electrical
System

Chassis

Electrical
Diagrams

This page is intentionally blank.



Table of Contents

SAFETY INSTRUCTIONS	2
Before Operating	2
While Operating	2
Maintenance and Service	3
JACKING INSTRUCTIONS	4
SAFETY AND INSTRUCTION DECALS	4

Safety Instructions

The Sand Pro and Infield Pro are designed and tested to offer safe service when operated and maintained properly. Although hazard control and accident prevention are partially dependent upon the design and configuration of the machine, these factors are also dependent upon the awareness, concern and proper training of the personnel involved in the operation, transport, maintenance and storage of the machine. Improper use or maintenance of the machine can result in injury

or death. To reduce the potential for injury or death, comply with the following safety instructions.



Before Operating

1. Read and understand the contents of the Operator's Manual before starting and operating the machine. Become familiar with the controls and know how to stop the machine quickly. A replacement Operator's Manual is available on the Internet at www.Toro.com or by sending the complete model and serial number to:

The Toro Company
Attn. Technical Publications
8111 Lyndale Avenue South
Bloomington, Minnesota 55420-1196

2. Keep all shields, safety devices and decals in place. If a shield, safety device or decal is defective, illegible or damaged, repair or replace it before operating the machine. Also, tighten any loose nuts, bolts or screws to ensure machine is in safe operating condition.

3. Wearing safety glasses, safety shoes, long pants and a helmet is advisable and required by some local safety and insurance regulations.

4. Ensure that the traction interlock switch is adjusted correctly so the engine cannot be started unless the traction pedal is released and in the neutral position.

5. Since gasoline is highly flammable, handle it carefully:

A. Store fuel in containers specifically designed for this purpose.

B. Do not remove machine fuel tank cap while engine is hot or running.

C. Do not smoke while handling fuel.

D. Fill fuel tank outdoors and only to within an inch of the top of the tank, not the filler neck. Do not overfill the fuel tank.

E. If fuel is spilled, do not start engine. Move the machine away from the area of spillage and allow the gasoline vapors to dissipate. Properly dispose of any spilled fuel.

While Operating

1. Operator should be in the operator's seat when operating the Sand Pro and Infield Pro. Never carry passengers.

2. Do not run engine in a confined area without adequate ventilation. Exhaust fumes are hazardous and could possibly be deadly.

3. Do not touch engine, muffler or exhaust system while engine is running or soon after it is stopped. These areas could be hot enough to cause burns.

4. If abnormal vibration is detected, stop machine immediately and determine source of vibration. Correct problems before resuming the use of the machine.

5. While operating, the machine may exceed noise levels of 85 dB(A) at the operator position. Hearing protection is recommended for prolonged exposure to reduce the potential of permanent hearing damage.

6. Before leaving the operator's position of the machine:

A. Stop movement of the machine.

B. Apply parking brake and lower attachment(s) to the ground. Take precautions to prevent accidental starts, rolling away, etc.

Maintenance and Service

1. Before servicing or making adjustments, position machine on a level surface and apply parking brake to prevent machine from moving.
2. Before servicing or making adjustments, disconnect the spark plug wires from the spark plugs and position the wires away from the spark plugs to ensure that the engine will not start unexpectedly.
3. Make sure machine is in safe operating condition by keeping all nuts, bolts and screws tight.
4. Never store the machine or fuel container inside where there is an open flame, such as near a water heater or furnace.
5. Make sure all hydraulic system line connectors are tight and all hydraulic system hoses and lines are in good condition before applying pressure to the hydraulic system.
6. Before disconnecting any hydraulic component or performing any work on the hydraulic system, all pressure in hydraulic system must be relieved.
7. Keep body and hands away from pin hole leaks or nozzles that eject hydraulic fluid under high pressure. Use paper or cardboard, not hands, to search for leaks. Hydraulic fluid escaping under pressure can have sufficient force to penetrate skin and do serious damage. If fluid is injected into the skin it must be surgically removed within a few hours by a doctor familiar with this form of injury or gangrene may result.
8. Do not overspeed the engine by changing governor setting. To assure safety and accuracy, check maximum engine speed with a tachometer.
9. Shut engine off before checking or adding oil to the engine crankcase.
10. To reduce potential fire hazard, keep engine area free of excessive grease, grass, leaves and dirt.
11. If the engine must be running to perform a maintenance adjustment, keep hands, feet, clothing and any parts of the body away from the engine and all moving parts. Also, keep bystanders away.
12. When changing tires or performing other service that requires the machine to be raised off the ground, make sure machine is properly supported. If the machine is not properly supported, the machine may move or fall, which may result in personal injury.
13. If major repairs are ever needed or assistance is desired, contact an Authorized Toro Distributor.
14. At the time of manufacture, the machine conformed to all applicable safety standards. To assure optimum performance and continued safety certification of the machine, use genuine Toro replacement parts and accessories. Replacement parts and accessories made by other manufacturers may result in non-conformance with the safety standards, and the warranty may be voided.

Jacking Instructions



CAUTION

When changing attachments, tires or performing other service, use correct blocks, hoists and jacks. Make sure machine is parked on a solid level floor such as a concrete floor. Prior to raising the machine, remove any attachments that may interfere with the safe and proper raising of the machine. Always chock or block wheels. Use jack stands or solid wood blocks to support the raised machine. If the machine is not properly supported by blocks or jack stands, the machine may move or fall, which may result in personal injury.

Use the following positions when jacking up the machine:

Front End Jacking

1. Jack the front of the machine from the bottom of the frame behind the front wheel (Fig. 1). Make sure that jack is positioned directly under frame to prevent damage to oil cooler.

Rear End Jacking

1. Jack the rear of the machine from below the wheel motor (Fig. 2).

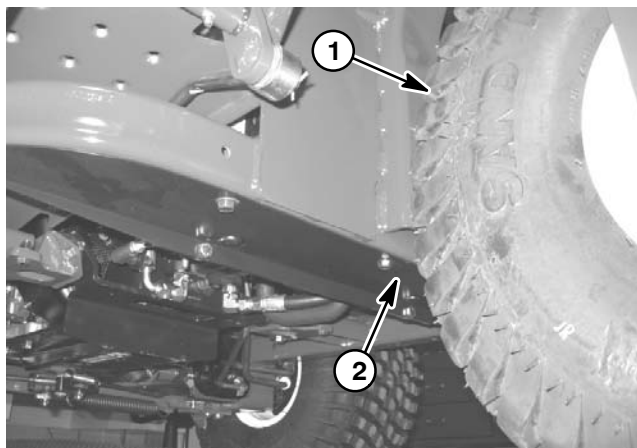

Figure 1

- 1. Front wheel
- 2. Front jacking point

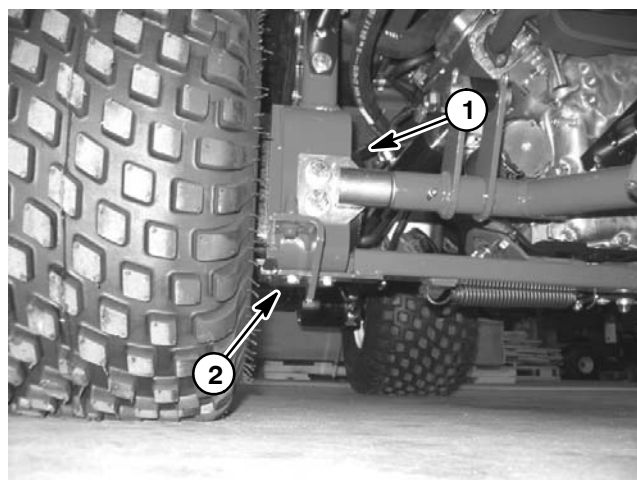

Figure 2

- 1. Rear wheel motor
- 2. Rear jacking point

Safety and Instruction Decals

Numerous safety and instruction decals are affixed to the Sand Pro and Infield Pro. If any decal becomes illegible or damaged, install a new decal. Part numbers for replacement decals are listed in your Parts Catalog. Order replacement decals from your Authorized Toro Distributor.



Product Records and Maintenance

Table of Contents

PRODUCT RECORDS	1	Standard Torque for Dry, Zinc Plated and	
MAINTENANCE	1	Steel Fasteners (Inch Series)	4
EQUIVALENTS AND CONVERSIONS	2	Standard Torque for Dry, Zinc Plated and	
Decimal and Millimeter Equivalents	2	Steel Fasteners (Metric Fasteners)	5
U.S. to Metric Conversions	2	Other Torque Specifications	6
TORQUE SPECIFICATIONS	3	Conversion Factors	6
Fastener Identification	3		

Product Records

Insert a copy of the Operator’s Manual and Parts Catalog for your Sand Pro or Infield Pro at the end of this chapter. Additionally, if any optional equipment or accessories have been installed to your machine, insert the Installation Instructions, Operator’s Manuals and Parts Catalogs for those options at the end of this chapter.

Maintenance

Maintenance procedures and recommended service intervals for Sand Pro and Infield Pro machines are covered in the Operator’s Manual. Refer to that publication when performing regular equipment maintenance.

Equivalents and Conversions

Decimal and Millimeter Equivalents

Fractions	Decimals	mm	Fractions	Decimals	mm		
	1/64	0.015625	— 0.397	33/64	0.515625	— 13.097	
	1/32	0.03125	— 0.794	17/32	0.53125	— 13.494	
	3/64	0.046875	— 1.191	35/64	0.546875	— 13.891	
1/16	—	0.0625	— 1.588	9/16	—	0.5625	— 14.288
	5/64	0.078125	— 1.984	37/64	0.578125	— 14.684	
	3/32	0.09375	— 2.381	19/32	—	0.59375	— 15.081
	7/64	0.109275	— 2.778	39/64	0.609375	— 15.478	
1/8	—	0.1250	— 3.175	5/8	—	0.6250	— 15.875
	9/64	0.140625	— 3.572	41/64	0.640625	— 16.272	
	5/32	0.15625	— 3.969	21/32	—	0.65625	— 16.669
	11/64	0.171875	— 4.366	43/64	0.671875	— 17.066	
3/16	—	0.1875	— 4.762	11/16	—	0.6875	— 17.462
	13/64	0.203125	— 5.159	45/64	0.703125	— 17.859	
	7/32	0.21875	— 5.556	23/32	—	0.71875	— 18.256
	15/64	0.234375	— 5.953	47/64	0.734375	— 18.653	
1/4	—	0.2500	— 6.350	3/4	—	0.7500	— 19.050
	17/64	0.265625	— 6.747	49/64	0.765625	— 19.447	
	9/32	0.28125	— 7.144	25/32	—	0.78125	— 19.844
	19/64	0.296875	— 7.541	51/64	0.796875	— 20.241	
5/16	—	0.3125	— 7.938	13/16	—	0.8125	— 20.638
	21/64	0.328125	— 8.334	53/64	0.828125	— 21.034	
	11/32	0.34375	— 8.731	27/32	—	0.84375	— 21.431
	23/64	0.359375	— 9.128	55/64	0.859375	— 21.828	
3/8	—	0.3750	— 9.525	7/8	—	0.8750	— 22.225
	25/64	0.390625	— 9.922	57/64	0.890625	— 22.622	
	13/32	0.40625	— 10.319	29/32	—	0.90625	— 23.019
	27/64	0.421875	— 10.716	59/64	0.921875	— 23.416	
7/16	—	0.4375	— 11.112	15/16	—	0.9375	— 23.812
	29/64	0.453125	— 11.509	61/64	0.953125	— 24.209	
	15/32	0.46875	— 11.906	31/32	—	0.96875	— 24.606
	31/64	0.484375	— 12.303	63/64	0.984375	— 25.003	
1/2	—	0.5000	— 12.700	1	—	1.000	— 25.400
	1 mm = 0.03937 in.			0.001 in. = 0.0254 mm			

U.S. to Metric Conversions

	To Convert	Into	Multiply By
Linear Measurement	Miles	Kilometers	1.609
	Yards	Meters	0.9144
	Feet	Meters	0.3048
	Feet	Centimeters	30.48
	Inches	Meters	0.0254
	Inches	Centimeters	2.54
	Inches	Millimeters	25.4
Area	Square Miles	Square Kilometers	2.59
	Square Feet	Square Meters	0.0929
	Square Inches	Square Centimeters	6.452
	Acre	Hectare	0.4047
Volume	Cubic Yards	Cubic Meters	0.7646
	Cubic Feet	Cubic Meters	0.02832
	Cubic Inches	Cubic Centimeters	16.39
Weight	Tons (Short)	Metric Tons	0.9078
	Pounds	Kilograms	0.4536
	Ounces (Avdp.)	Grams	28.3495
Pressure	Pounds/Sq. In.	Kilopascal	6.895
	Pounds/Sq. In.	Bar	0.069
Work	Foot-pounds	Newton-Meters	1.356
	Foot-pounds	Kilogram-Meters	0.1383
	Inch-pounds	Kilogram-Centimeters	1.152144
Liquid Volume	Quarts	Liters	0.9463
	Gallons	Liters	3.785
Liquid Flow	Gallons/Minute	Liters/Minute	3.785
Temperature	Fahrenheit	Celsius	1. Subtract 32°
			2. Multiply by 5/9

Torque Specifications

Recommended fastener torque values are listed in the following tables. For critical applications, as determined by Toro, either the recommended torque or a torque that is unique to the application is clearly identified and specified in this Service Manual.

These Torque Specifications for the installation and tightening of fasteners shall apply to all fasteners which do not have a specific requirement identified in this Service Manual. The following factors shall be considered when applying torque: cleanliness of the fastener, use of a thread sealant (e.g. Loctite), degree of lubrication on the fastener, presence of a prevailing torque feature (e.g. Nylock nut), hardness of the surface underneath the fastener's head or similar condition which affects the installation.

As noted in the following tables, torque values should be **reduced by 25% for lubricated fasteners** to achieve the similar stress as a dry fastener. Torque values may also have to be reduced when the fastener is threaded into aluminum or brass. The specific torque value should be determined based on the aluminum or brass material strength, fastener size, length of thread engagement, etc.

The standard method of verifying torque shall be performed by marking a line on the fastener (head or nut) and mating part, then back off fastener 1/4 of a turn. Measure the torque required to tighten the fastener until the lines match up.

Fastener Identification

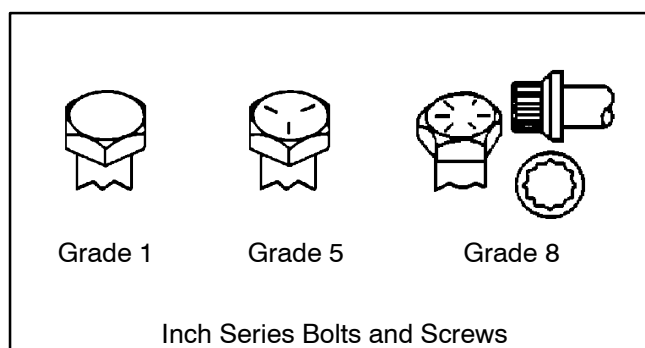

Figure 1

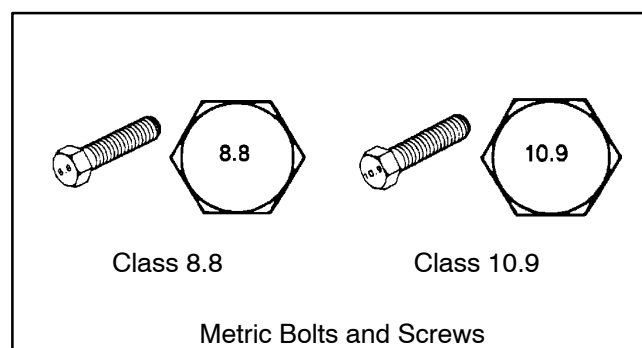

Figure 2

Standard Torque for Dry, Zinc Plated and Steel Fasteners (Inch Series)

Thread Size	Grade 1, 5 & 8 with Thin Height Nuts	SAE Grade 1 Bolts, Screws, Studs & Sems with Regular Height Nuts (SAE J995 Grade 2 or Stronger Nuts)		SAE Grade 5 Bolts, Screws, Studs & Sems with Regular Height Nuts (SAE J995 Grade 2 or Stronger Nuts)		SAE Grade 8 Bolts, Screws, Studs & Sems with Regular Height Nuts (SAE J995 Grade 5 or Stronger Nuts)	
	in-lb	in-lb	N-cm	in-lb	N-cm	in-lb	N-cm
# 6 – 32 UNC	10 ± 2	13 ± 2	147 ± 23	15 ± 2	169 ± 23	23 ± 3	262 ± 34
# 6 – 40 UNF				17 ± 2	192 ± 23	25 ± 3	282 ± 34
# 8 – 32 UNC	13 ± 2	25 ± 5	282 ± 56	29 ± 3	328 ± 34	41 ± 5	463 ± 56
# 8 – 36 UNF				31 ± 4	350 ± 45	43 ± 5	486 ± 56
# 10 – 24 UNC	18 ± 2	30 ± 5	339 ± 56	42 ± 5	475 ± 56	60 ± 6	678 ± 68
# 10 – 32 UNF				48 ± 5	542 ± 56	68 ± 7	768 ± 79
1/4 – 20 UNC	48 ± 7	53 ± 7	599 ± 79	100 ± 10	1130 ± 113	140 ± 15	1582 ± 169
1/4 – 28 UNF	53 ± 7	65 ± 10	734 ± 113	115 ± 12	1299 ± 136	160 ± 17	1808 ± 192
5/16 – 18 UNC	115 ± 15	105 ± 15	1186 ± 169	200 ± 25	2260 ± 282	300 ± 30	3390 ± 339
5/16 – 24 UNF	138 ± 17	128 ± 17	1446 ± 192	225 ± 25	2542 ± 282	325 ± 33	3672 ± 373
	ft-lb	ft-lb	N-m	ft-lb	N-m	ft-lb	N-m
3/8 – 16 UNC	16 ± 2	16 ± 2	22 ± 3	30 ± 3	41 ± 4	43 ± 5	58 ± 7
3/8 – 24 UNF	17 ± 2	18 ± 2	24 ± 3	35 ± 4	47 ± 5	50 ± 6	68 ± 8
7/16 – 14 UNC	27 ± 3	27 ± 3	37 ± 4	50 ± 5	68 ± 7	70 ± 7	95 ± 9
7/16 – 20 UNF	29 ± 3	29 ± 3	39 ± 4	55 ± 6	75 ± 8	77 ± 8	104 ± 11
1/2 – 13 UNC	30 ± 3	48 ± 7	65 ± 9	75 ± 8	102 ± 11	105 ± 11	142 ± 15
1/2 – 20 UNF	32 ± 4	53 ± 7	72 ± 9	85 ± 9	115 ± 12	120 ± 12	163 ± 16
5/8 – 11 UNC	65 ± 10	88 ± 12	119 ± 16	150 ± 15	203 ± 20	210 ± 21	285 ± 28
5/8 – 18 UNF	75 ± 10	95 ± 15	129 ± 20	170 ± 18	230 ± 24	240 ± 24	325 ± 33
3/4 – 10 UNC	93 ± 12	140 ± 20	190 ± 27	265 ± 27	359 ± 37	375 ± 38	508 ± 52
3/4 – 16 UNF	115 ± 15	165 ± 25	224 ± 34	300 ± 30	407 ± 41	420 ± 43	569 ± 58
7/8 – 9 UNC	140 ± 20	225 ± 25	305 ± 34	430 ± 45	583 ± 61	600 ± 60	813 ± 81
7/8 – 14 UNF	155 ± 25	260 ± 30	353 ± 41	475 ± 48	644 ± 65	667 ± 66	904 ± 89

NOTE: Torque values may have to be reduced when installing fasteners into threaded aluminum or brass. The specific torque value should be determined based on the fastener size, the aluminum or base material strength, length of thread engagement, etc.

NOTE: Reduce torque values listed in the table above by 25% for lubricated fasteners. Lubricated fasteners are defined as threads coated with a lubricant such as engine oil or thread sealant such as Loctite.

NOTE: The nominal torque values listed above for Grade 5 and 8 fasteners are based on 75% of the minimum proof load specified in SAE J429. The tolerance is approximately ± 10% of the nominal torque value. Thin height nuts include jam nuts.

Standard Torque for Dry, Zinc Plated and Steel Fasteners (Metric Fasteners)

Thread Size	Class 8.8 Bolts, Screws and Studs with Regular Height Nuts (Class 8 or Stronger Nuts)		Class 10.9 Bolts, Screws and Studs with Regular Height Nuts (Class 10 or Stronger Nuts)	
M5 X 0.8	57 ± 6 in-lb	644 ± 68 N-cm	78 ± 8 in-lb	881 ± 90 N-cm
M6 X 1.0	96 ± 10 in-lb	1085 ± 113 N-cm	133 ± 14 in-lb	1503 ± 158 N-cm
M8 X 1.25	19 ± 2 ft-lb	26 ± 3 N-m	28 ± 3 ft-lb	38 ± 4 N-m
M10 X 1.5	38 ± 4 ft-lb	52 ± 5 N-m	54 ± 6 ft-lb	73 ± 8 N-m
M12 X 1.75	66 ± 7 ft-lb	90 ± 10 N-m	93 ± 10 ft-lb	126 ± 14 N-m
M16 X 2.0	166 ± 17 ft-lb	225 ± 23 N-m	229 ± 23 ft-lb	310 ± 31 N-m
M20 X 2.5	325 ± 33 ft-lb	440 ± 45 N-m	450 ± 46 ft-lb	610 ± 62 N-m

Product Records and Maintenance

NOTE: Torque values may have to be reduced when installing fasteners into threaded aluminum or brass. The specific torque value should be determined based on the fastener size, the aluminum or base material strength, length of thread engagement, etc.

NOTE: The nominal torque values listed above are based on 75% of the minimum proof load specified in SAE J1199. The tolerance is approximately ± 10% of the nominal torque value.

NOTE: Reduce torque values listed in the table above by 25% for lubricated fasteners. Lubricated fasteners are defined as threads coated with a lubricant such as engine oil or thread sealant such as Loctite.

Other Torque Specifications

SAE Grade 8 Steel Set Screws

Thread Size	Recommended Torque	
	Square Head	Hex Socket
1/4 – 20 UNC	140 ± 20 in-lb	73 ± 12 in-lb
5/16 – 18 UNC	215 ± 35 in-lb	145 ± 20 in-lb
3/8 – 16 UNC	35 ± 10 ft-lb	18 ± 3 ft-lb
1/2 – 13 UNC	75 ± 15 ft-lb	50 ± 10 ft-lb

Wheel Bolts and Lug Nuts

Thread Size	Recommended Torque**	
	ft-lb	N-m
7/16 – 20 UNF Grade 5	65 ± 10	88 ± 14
1/2 – 20 UNF Grade 5	80 ± 10	108 ± 14
M12 X 1.25 Class 8.8	80 ± 10	108 ± 14
M12 X 1.5 Class 8.8	80 ± 10	108 ± 14

** For steel wheels and non-lubricated fasteners.

Thread Cutting Screws (Zinc Plated Steel)

Type 1, Type 23 or Type F	
Thread Size	Baseline Torque*
No. 6 – 32 UNC	20 ± 5 in-lb
No. 8 – 32 UNC	30 ± 5 in-lb
No. 10 – 24 UNC	38 ± 7 in-lb
1/4 – 20 UNC	85 ± 15 in-lb
5/16 – 18 UNC	110 ± 20 in-lb
3/8 – 16 UNC	200 ± 100 in-lb

Thread Cutting Screws (Zinc Plated Steel)

Thread Size	Threads per Inch		Baseline Torque*
	Type A	Type B	
No. 6	18	20	20 ± 5 in-lb
No. 8	15	18	30 ± 5 in-lb
No. 10	12	16	38 ± 7 in-lb
No. 12	11	14	85 ± 15 in-lb

* Hole size, material strength, material thickness & finish must be considered when determining specific torque values. All torque values are based on non-lubricated fasteners.

Conversion Factors

$$\text{in-lb} \times 11.2985 = \text{N-cm}$$

$$\text{ft-lb} \times 1.3558 = \text{N-m}$$

$$\text{N-cm} \times 0.08851 = \text{in-lb}$$

$$\text{N-m} \times 0.7376 = \text{ft-lb}$$



Table of Contents

INTRODUCTION 2
SPECIFICATIONS 3
GENERAL INFORMATION 4
 Fuel Shut-off Valve 4
SERVICE AND REPAIRS 5
 Cooling System 5
 Air Cleaner Assembly 6
 Fuel Tank 8
 Engine 10
 Engine Removal 10
 Engine Installation 12
BRIGGS & STRATTON REPAIR MANUAL FOR
4-CYCLE, V-TWIN CYLINDER, OHV HEAD EN-
GINES

Introduction

This Chapter gives information about specifications, maintenance, troubleshooting, testing and repair of the Briggs and Stratton gasoline engine used in Sand Pro and Infield Pro machines.

Most repairs and adjustments require tools which are commonly available in many service shops. Special tools are described in the Briggs and Stratton Repair Manual that is included at the end of this Chapter. The use of some specialized test equipment is explained. However, the cost of the test equipment and the specialized nature of some repairs may dictate that the work be done at an engine repair facility.

Service and repair parts for the Briggs and Stratton engine used to power the Sand Pro or Infield Pro are supplied through your local Toro distributor or your local Briggs and Stratton dealer or distributor. If no parts list is available, be prepared to provide your distributor with the Toro equipment model and serial numbers as well as the Briggs and Stratton engine model and serial numbers.

Specifications

Item	Description
Engine Make / Designation	Briggs and Stratton, 4-cycle, V-Twin Cylinder, OHV, Air Cooled, Gasoline Engine
Bore x Stroke Sand Pro & Infield Pro 3040 Sand Pro & Infield Pro 5040	2.68" x 2.60" (68mm x 66mm) 2.83" x 2.75" (72mm x 70mm)
Engine Displacement Sand Pro & Infield Pro 3040 Sand Pro & Infield Pro 5040	29.3 cu in (480cc) 34.8 cu in (570cc)
Fuel	Unleaded Regular Grade Gasoline
Fuel Capacity	5.0 US gallons (18.9 liters)
Fuel Pump	Pulsating Crankcase Vacuum
Carburetor	Float Feed, Single Barrel
Governor	Mechanical
High Idle Speed (No Load)	3400 ± 50 RPM
Low Idle Speed (No Load)	1750 ± 100 RPM
Lubrication System	Pressure Lubrication
Oil Pump	Gear Driven Geroter Type
Crankcase Oil Capacity	1.75 US quarts (1.66 liters) with new filter
Engine Oil	See Operator's Manual
Spark Plugs	Champion RC 14YC (or equivalent)
Spark Plug Gap	0.030" (0.76mm)
Starter	12 VDC
Alternator	12 VDC / 15 Amps
Engine Weight (approximate) Sand Pro & Infield Pro 3040 Sand Pro & Infield Pro 5040	72 lb (32.7 kg) 74 lb (33.6 kg)

General Information

Fuel Shut Off Valve

The fuel shut off valve located under the fuel tank (Fig. 1) should be closed if the machine is being transported on a trailer or when placing the machine in long term storage. Additionally, close the shut off valve when removing the fuel tank or engine from the machine.

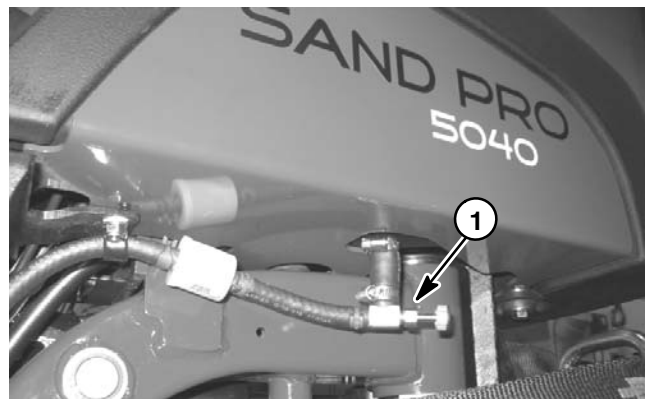

Figure 1

1. Fuel shut-off valve

Service and Repairs

Cooling System

To ensure proper engine cooling, make sure the rotating screen, cooling fins and other external surfaces of the engine are kept clean at all times.

NOTE: Perform this maintenance procedure at the interval specified in the Operator's Manual.

IMPORTANT: The engine that powers Sand Pro and Infield Pro machines is air-cooled. Operating the engine with dirty or plugged cooling fins, a blocked rotating screen or a plugged or dirty blower housing will result in engine overheating and engine damage.

1. Park machine on a level surface, lower attachment, stop engine, apply parking brake and remove key from ignition switch.



CAUTION

The engine and exhaust system may be hot. To avoid possible burns, allow the engine and exhaust system to cool before working on the engine.

IMPORTANT: Never clean engine with pressurized water. Water could enter and contaminate the fuel system.

2. Clean cooling fins on both cylinder heads.

3. Clean rotating screen and blower housing of dirt and debris (Fig. 2).

4. If blower housing removal is necessary for cooling system cleaning, engine needs to be removed from machine (see Engine Removal and Installation in this section).

IMPORTANT: Never operate engine without the blower housing installed. Overheating and engine damage will result.

5. Make sure rotating screen and blower housing are reinstalled to the engine if removed.

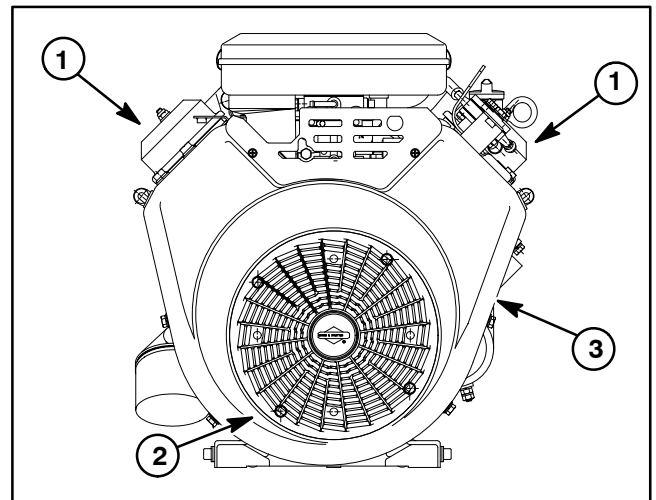

Figure 2

- 1. Cylinder head
- 2. Rotating screen
- 3. Blower housing

Air Cleaner Assembly

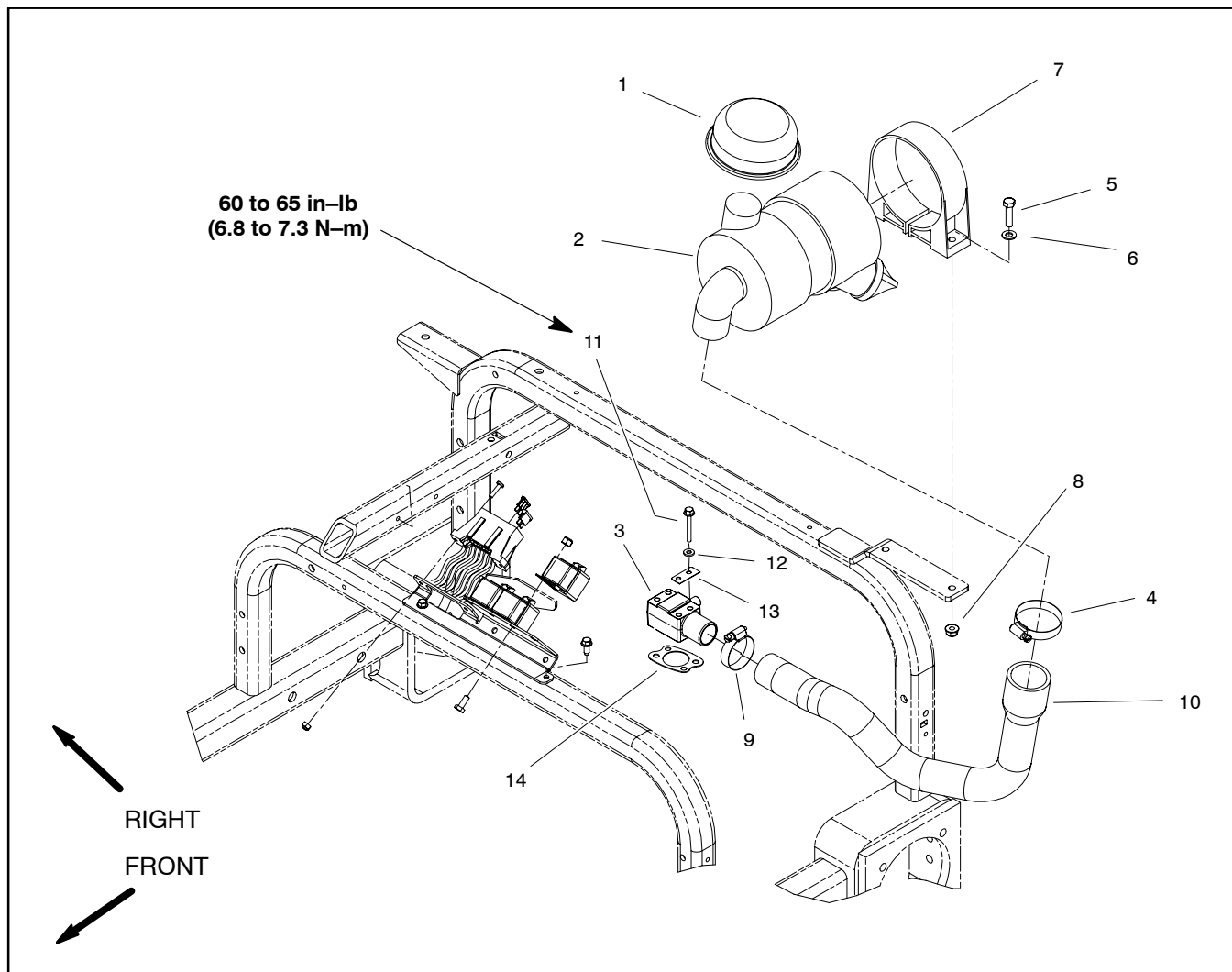

Figure 3

- 1. Inlet hood
- 2. Air cleaner assembly
- 3. Intake elbow
- 4. Hose clamp
- 5. Cap screw (2 used)

- 6. Flat washer (2 used)
- 7. Mounting bracket
- 8. Lock nut (2 used)
- 9. Hose clamp
- 10. Air hose

- 11. Flange head screw (4 used)
- 12. Flat washer (4 used)
- 13. Gasket (2 used)
- 14. Intake gasket

Removal (Fig. 3)

NOTE: See Operator's Manual for air cleaner maintenance procedures and intervals.

1. Park machine on a level surface, lower attachment, stop engine, apply parking brake and remove key from ignition switch.
2. Remove air cleaner components as needed using Figure 3 as a guide.
3. Check air cleaner assembly for damage that could cause possible air leaks (Fig. 4). Make sure that air cleaner cover seals completely to the air cleaner housing.

Installation (Fig. 3)

IMPORTANT: Any leaks in the air filter system will allow dirt into the engine and will cause serious engine damage. Make sure that all air cleaner components are in good condition and are properly secured during assembly.

1. Assemble air cleaner system using Figure 3 as a guide. Make sure that vacuator valve is pointed down after assembly (Fig. 4).

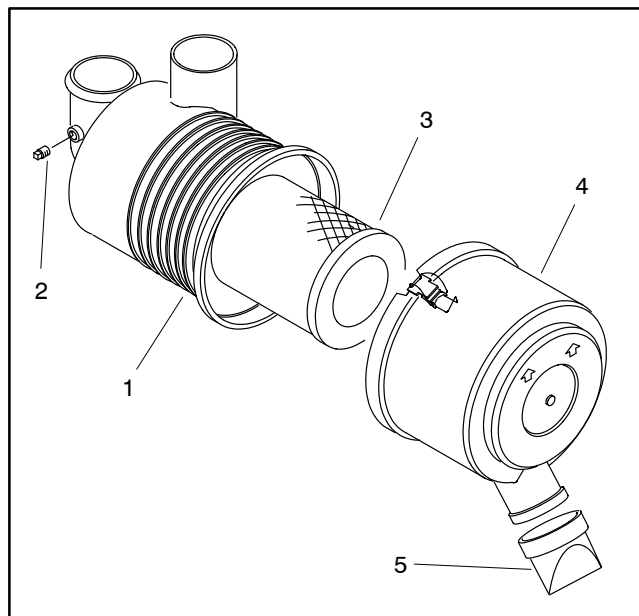

Figure 4

- | | |
|------------------------|----------------------|
| 1. Air cleaner housing | 4. Air cleaner cover |
| 2. Pipe plug | 5. Vacuator valve |
| 3. Filter element | |

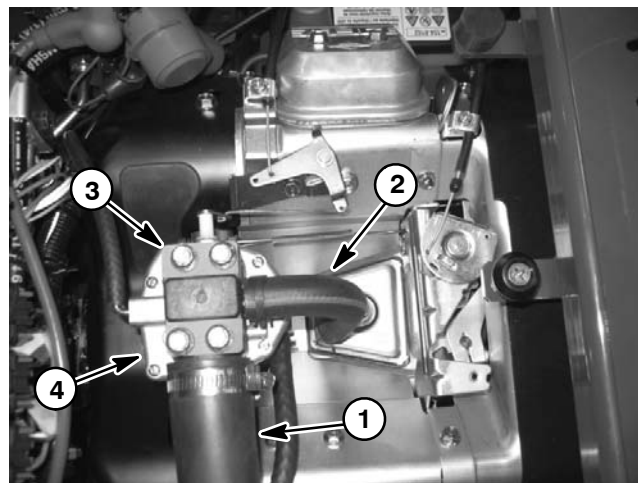

Figure 5

- | | |
|------------------|-----------------|
| 1. Air hose | 3. Intake elbow |
| 2. Breather tube | 4. Carburetor |

Fuel Tank

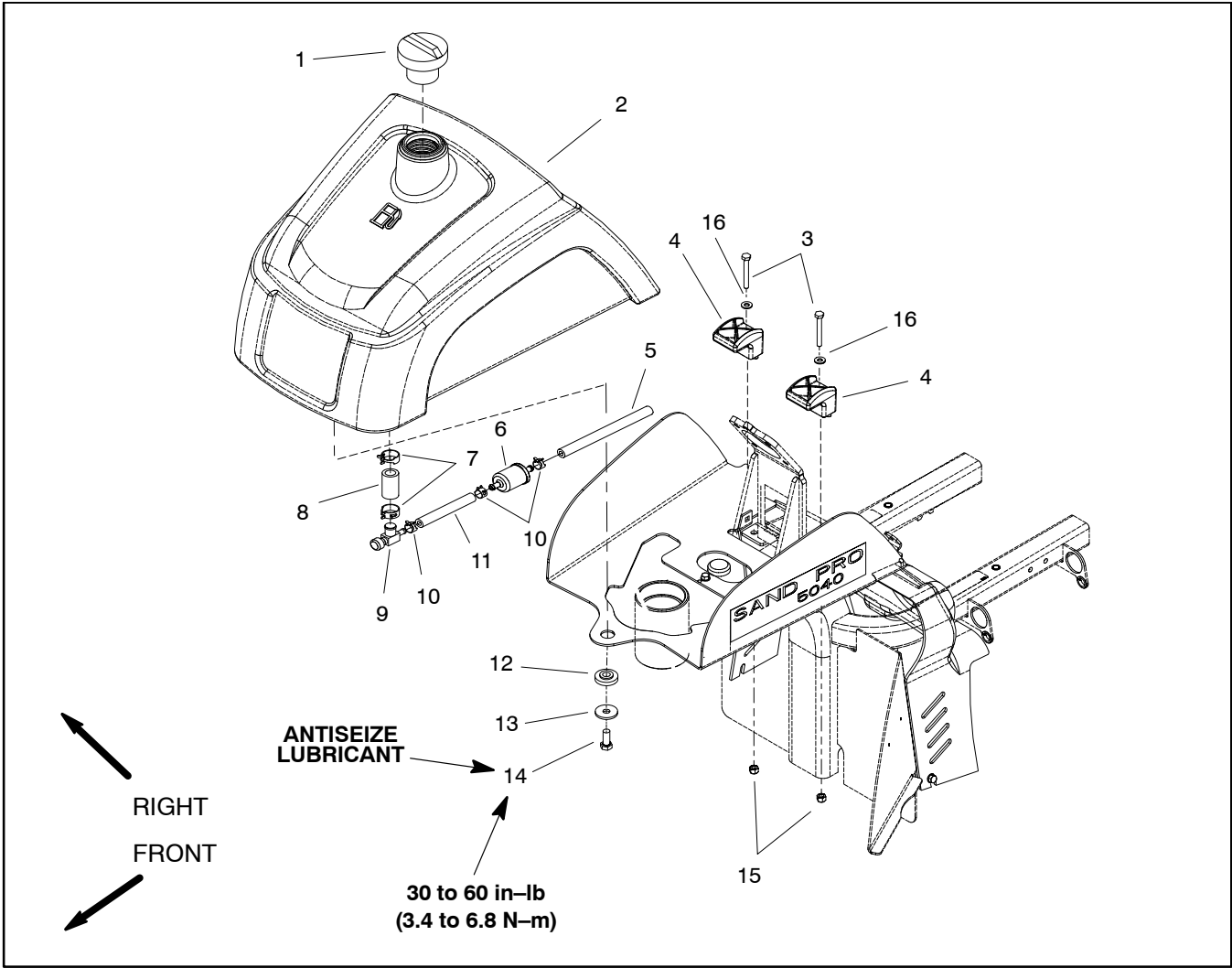

Figure 6

- | | | |
|----------------|------------------------|--------------------|
| 1. Fuel cap | 7. Hose clamp | 12. Flange bushing |
| 2. Fuel tank | 8. Fuel hose | 13. Washer |
| 3. Cap screw | 9. Fuel shut off valve | 14. Cap screw |
| 4. Clamp | 10. Hose clamp | 15. Lock nut |
| 5. Fuel hose | 11. Fuel hose | 16. Flat washer |
| 6. Fuel filter | | |



DANGER

Because gasoline is highly flammable, use caution when storing or handling it. Do not smoke while filling the fuel tank. Do not fill fuel tank while engine is running, hot or when machine is in an enclosed area. Always fill fuel tank outside and clean up any spilled fuel before starting the engine. Store fuel in a clean, safety-approved container and keep fuel cap in place. Use gasoline for the engine only; not for any other purpose.

Check Fuel Lines and Connections

Check fuel lines and connections periodically as recommended in the Operator's Manual. Check lines for deterioration, damage, leaks or loose connections. Replace hoses, clamps and connections as necessary.

Drain and Clean Fuel Tank

IMPORTANT: If fuel tank is to be drained, drain fuel outdoors.

Drain and clean the fuel tank periodically as recommended in the Operator's Manual. Also, drain and clean the fuel tank if the fuel system becomes contaminated or if the machine is to be stored for an extended period.

To clean fuel tank, flush tank and fuel hoses out with clean solvent. Make sure tank is free of contaminants and debris.

Fuel Tank Removal (Fig. 6)

1. Park machine on a level surface, lower attachment, stop engine, apply parking brake and remove key from ignition switch.

2. Close fuel shut off valve (Fig. 7). Disconnect fuel hose from fuel filter inlet.

3. Place disconnected hose in appropriate container and open fuel shut off valve to allow fuel tank to drain completely.

4. Remove three (3) washer head screws that retain dash panel to fuel tank (Fig. 8). Carefully position panel away from fuel tank.

5. Remove fuel tank from machine using Figure 6 as a guide.

6. If fuel in tank was contaminated, carburetor removal and cleaning may be necessary (see Briggs and Stratton Repair Manual at the end of this chapter).

Fuel Tank Installation (Fig. 6)

1. If carburetor was removed from engine for cleaning, install carburetor (see Briggs and Stratton Repair Manual at the end of this chapter).

2. Install fuel tank to frame using Figure 6 as a guide. Apply antiseize lubricant to cap screw (item 14) that secures front of fuel tank to machine. Install and torque cap screw from 30 to 60 in-lb (3.4 to 6.8 N-m).

3. Connect fuel hose to fuel filter inlet. Make sure that fuel hose is secured with hose clamps.

4. Position panel to fuel tank and secure with three (3) washer head screws (Fig. 8).

5. Fill fuel tank (see Operator's Manual).

6. Open fuel shut off valve and check for any signs of fuel leakage.

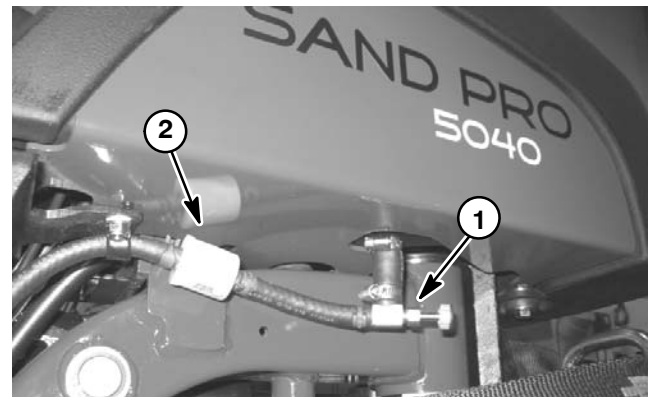

Figure 7

1. Fuel shut off valve 2. Fuel filter

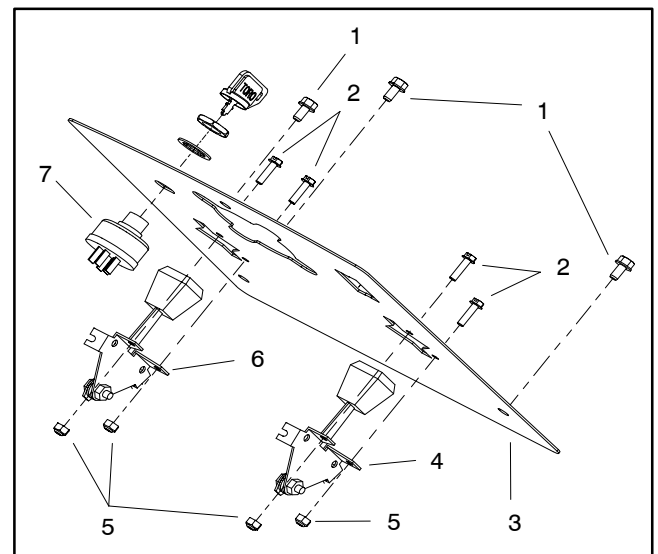

Figure 8

1. Washer head screw 5. Lock nut
2. Screw 6. Throttle lever/cable
3. Dash panel 7. Ignition switch
4. Choke lever/cable

Engine

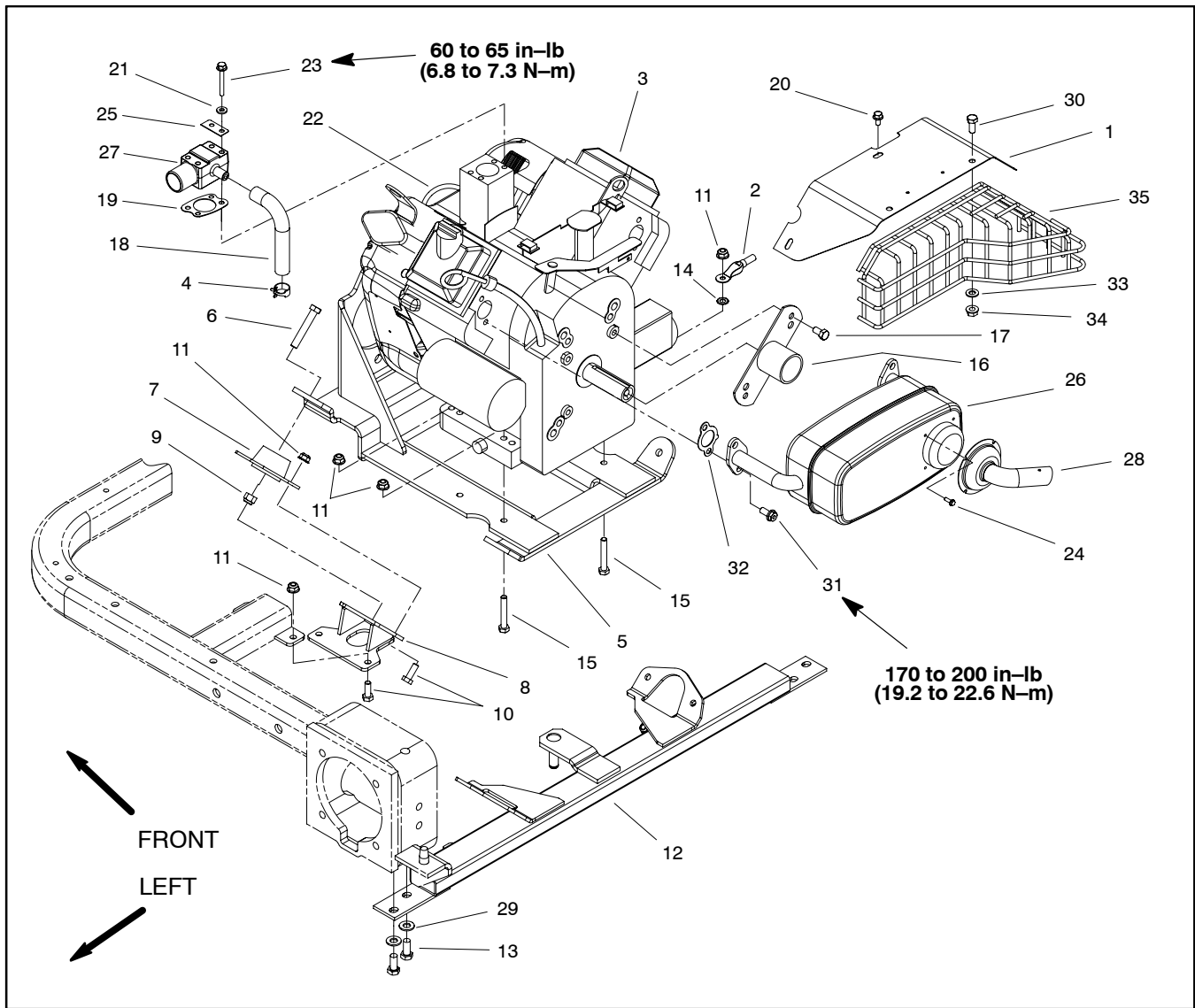

Figure 9

- | | | |
|---------------------------------|--------------------------------|--------------------------------|
| 1. Muffler shield | 13. Cap screw (4 used) | 25. Gasket (2 used) |
| 2. Negative battery cable | 14. Lock washer | 26. Muffler |
| 3. Engine | 15. Cap screw (4 used) | 27. Intake elbow |
| 4. Hose clamp (2 used) | 16. Crankshaft cover | 28. Tail pipe |
| 5. Engine support | 17. Cap screw (2 used) | 29. Flat washer (4 used) |
| 6. Cap screw (4 used) | 18. Breather tube | 30. Cap screw (3 used) |
| 7. Engine mount (4 used) | 19. Intake gasket | 31. Flange head screw (4 used) |
| 8. Front mount bracket (2 used) | 20. Flange head screw (3 used) | 32. Exhaust gasket (2 used) |
| 9. Flange nut (4 used) | 21. Flat washer (4 used) | 33. Flat washer (3 used) |
| 10. Cap screw | 22. Hose | 34. Flange nut (3 used) |
| 11. Flange nut | 23. Flange head screw (4 used) | 35. Exhaust shield |
| 12. Engine mount | 24. Washer head screw (4 used) | |

Engine Removal (Fig. 9)

1. Park machine on a level surface, lower attachment, stop engine, apply parking brake and remove key from ignition switch.

2. If engine is to be disassembled, it may be easier to drain oil from engine before removing engine from machine (see Operator's Manual).

3. Chock wheels to prevent the machine from moving.

4. Remove rear attachment from machine.

	CAUTION
<p>The engine and exhaust system may be hot. To avoid possible burns, allow the engine and exhaust system to cool before removing engine from machine.</p>	

5. Remove hitch assembly from the rear of the machine (see Hitch Assembly Removal in the Service and Repairs section of Chapter 6 – Chassis).

6. Raise operator seat.

	CAUTION
<p>When disconnecting the battery cables from the battery, make sure to remove the negative (-) battery cable first and then remove the positive (+) battery cable.</p>	

7. Disconnect and remove battery from the machine to prevent the possibility of the engine damaging it during removal (see Battery Service in the Service and Repairs section of Chapter 5 – Electrical Systems).

8. Close fuel shutoff valve. Clamp fuel hose near engine to prevent fuel spillage. Loosen hose clamp at fuel pump and remove fuel hose from the pump.

9. Disconnect machine wire harness from engine as follows (Fig. 10):

- A. Disconnect harness violet wire from engine magneto terminal.
- B. Disconnect harness fusible link from voltage regulator on engine blower housing.
- C. Disconnect harness yellow wire from engine fuel solenoid lead.

10. Remove air intake hose from air cleaner assembly and engine intake elbow (see Air Cleaner Assembly Removal in this section).

11. Disconnect breather tube from intake elbow.

12. Remove four (4) flange head screws that secure intake elbow to carburetor. Remove two (2) gaskets and intake manifold. Discard gaskets. Remove and discard intake gasket from between intake elbow and carburetor. Make sure that all gasket material is removed from carburetor and intake elbow.

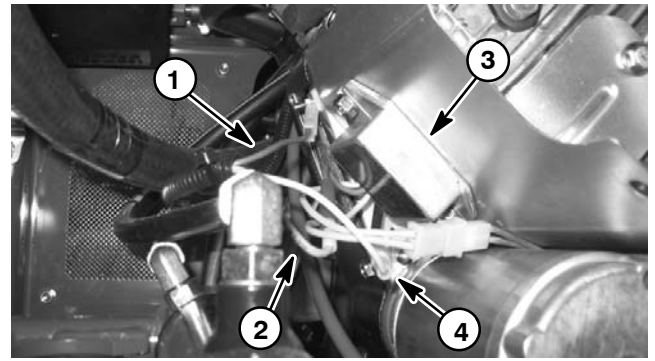

Figure 10

- | | |
|--------------------------------|----------------------|
| 1. Violet wire (magneto) | 3. Voltage regulator |
| 2. Fusible link (voltage reg.) | 4. Yellow wire |

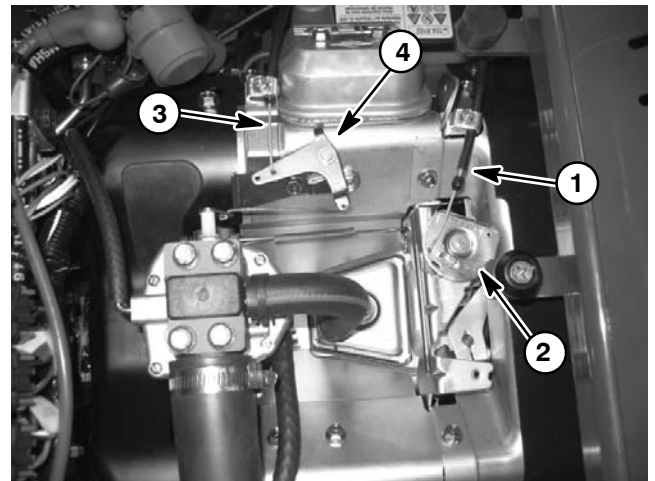

Figure 11

- | | |
|---------------------------|----------------|
| 1. Throttle control cable | 3. Choke cable |
| 2. Governor control plate | 4. Choke lever |

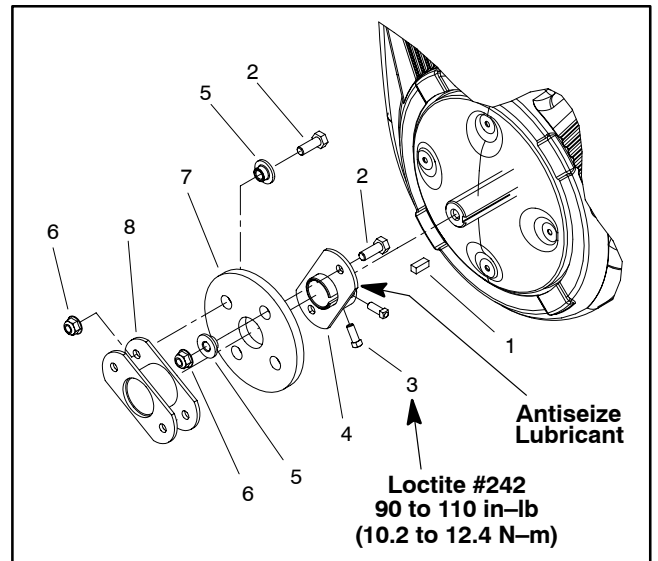

Figure 12

- | | |
|---------------|--------------------|
| 1. Square key | 5. Coupling spacer |
| 2. Cap screw | 6. Lock nut |
| 3. Set screw | 7. Drive coupling |
| 4. Engine hub | 8. Coupling |

Gasoline Engine

13. Disconnect throttle control cable from the governor control plate and choke control cable from the choke lever (Fig. 11).

14. Disconnect red positive cable (solenoid) from the starter motor.

15. Loosen two (2) set screws on the engine hub to allow hub removal from the engine stub shaft (Fig. 12).

16. Remove lock nut and cap screw securing engine and negative battery cable to the engine support. Locate and retrieve lock washer (item 14). Position cable away from engine.

17. Remove remaining three (3) lock nuts and cap screws that secure the engine to the engine support.

IMPORTANT: Make sure not to damage the engine, fuel lines, hydraulic lines, electrical harness or other parts while removing the engine from the machine.

18. Remove engine from machine as follows:

A. Slide engine toward the rear of machine to remove engine stub shaft from engine hub. Take care not to damage the hydrostat coupling.

B. Once the engine stub shaft is clear of the engine hub, remove engine from the rear of the machine.

C. Locate and retrieve square key from the engine stub shaft.

Engine Installation (Fig. 9)

1. Position machine on a level surface.

2. Make sure that all parts removed from the engine during maintenance or rebuilding are properly installed to the engine.

IMPORTANT: Make sure not to damage the engine, fuel lines, hydraulic lines, electrical harness or other parts while installing the engine.

3. Install engine to machine as follows:

A. Apply antiseize lubricant to bore of engine hub. Place square key into slot on the engine stub shaft.

B. Position engine onto engine support from the rear of the machine.

C. Align engine stub shaft to engine hub. Slide engine toward the front of machine until mounting holes in engine align with holes in engine support. Take care not to damage the hydrostat coupling.

D. Install three (3) cap screws and lock nuts to secure the engine to the engine support. Do not fully tighten lock nuts.

E. Position lock washer and negative battery cable to the engine. Lock washer should be positioned between engine and ground cable. Install fourth cap screw up through engine support, engine, lock washer and ground cable and then install lock nut. Do not fully tighten lock nut.

F. Rotate engine crankshaft by hand and check for deflection of pump couplers that would indicate misalignment between engine and hydrostat. Position engine on engine support to best align the coupling assembly.

G. Tighten four (4) cap screws and lock nuts to secure engine to machine.

4. Position engine hub on engine stub shaft so that rubber pump drive couplings are not distorted. Apply Loctite #242 (or equivalent) to threads of engine hub set screws. Tighten both set screws on the engine hub to secure hub to the engine stub shaft (Fig. 12). Torque set screws from 90 to 110 in-lb (10.2 to 12.4 N-m).

5. Connect throttle control cable to the governor control plate and choke control cable to the choke lever (Fig. 11).

6. Connect positive cable (solenoid) to starter motor.

7. Connect machine wire harness leads to engine as follows (Fig. 10):

A. Connect harness violet wire to the engine magneto terminal.

B. Connect harness fusible link to voltage regulator on engine blower housing.

C. Connect harness yellow wire to engine fuel solenoid lead.

 CAUTION
When connecting the battery cables to the battery, make sure to attach the positive (+) battery cable first and then attach the negative (-) battery cable.

8. Install and connect battery to the machine (see Battery Service in the Service and Repairs section of Chapter 5 – Electrical Systems).

9. Secure fuel hose to the fuel pump with hose clamp. Remove clamp from fuel hose that was used to prevent fuel spillage. Open fuel shutoff valve.

10. Place new intake gasket on carburetor. Position intake elbow to top of carburetor. Place two (2) gaskets to top of intake elbow and secure intake elbow with four (4) flange head screws. Torque cap screws from 60 to 65 in-lbs (6.8 to 7.3 N-m).

IMPORTANT: Any leaks in the air filter system will allow dirt into engine and will cause serious engine damage. Make sure that all air cleaner components and breather tube are in good condition and are properly secured during assembly.

11. Secure breather tube to intake elbow. Make sure that hose clamps are properly tightened.

12. Secure air intake hose to air cleaner assembly and engine (see Air Cleaner Assembly Installation in this section). Make sure that hose clamps are properly tightened.

13. Install hitch assembly to the rear of the machine (see Hitch Assembly Installation in the Service and Repairs section of Chapter 6 – Chassis).

14. Install attachment to the machine.

15. Lower operator seat.

16. Check and adjust engine oil level (See Operator's Manual).

17. Check operation of choke and throttle cables. Adjust if necessary (see Operator's Manual).

This page is intentionally blank.



Hydraulic System

Hydraulic System

Table of Contents

SPECIFICATIONS	2	Check Hydraulic Lines and Hoses	34
GENERAL INFORMATION	3	Flush Hydraulic System	35
Hydraulic Hoses	3	Charge Hydraulic System	36
Hydraulic Fitting Installation	3	Hydraulic Tank	38
Towing	5	Oil Cooler	40
Relieving Hydraulic System Pressure	5	Front Wheel Motor	42
Traction Circuit Component Failure	5	Rear Wheel Motor	44
Optional Hydraulic Accessories	5	Wheel Motor Service	46
HYDRAULIC SCHEMATICS	6	Lift Control Valve	48
Sand Pro 3040 and Infield Pro 3040	6	Lift Control Valve Service	50
Sand Pro 3040 and Infield Pro 3040 (Including Optional Hydraulic Kits)	7	Pump Control Assembly	52
Sand Pro 5040 and Infield Pro 5040	8	Hydrostat	54
Sand Pro 5040 and Infield Pro 5040 (Including Optional Hydraulic Kits)	9	Hydrostat Service	58
HYDRAULIC FLOW DIAGRAMS	10	Lift Cylinder	60
Traction Circuit	10	Lift Cylinder Service	62
Lift Circuit	12	Steering Control Valve (Sand Pro 5040 and Infield Pro 5040)	64
Steering Circuit	14	Steering Control Valve Service (Sand Pro 5040 and Infield Pro 5040)	66
SPECIAL TOOLS	16	Steering Cylinder (Sand Pro 5040 and Infield Pro 5040)	68
TROUBLESHOOTING	19	Steering Cylinder Service (Sand Pro 5040 and Infield Pro 5040)	70
TESTING	21	PARKER TORQMOTOR™ SERVICE PROCEDURE (TC, TB, TE, TJ, TF, TG, TH AND TL SERIES)	
Charge Pressure and Implement Relief Valve (R1) Pressure Tests	22	SAUER-DANFOSS (SUNDSTRAND) 15 SERIES RE- PAIR MANUAL	
Traction Relief Valve (R3) Pressure Test	24	SAUER-DANFOSS (SUNDSTRAND) 15 SERIES SERVICE MANUAL	
Traction Pump (P1) Flow Test	26	SAUER-DANFOSS STEERING UNIT TYPE OSPM SERVICE MANUAL	
Wheel Motor Efficiency Test	28		
Charge Pump (P2) Flow Test	30		
Steering Cylinder Internal Leakage Test (Sand Pro 5040 and Infield Pro 5040)	32		
SERVICE AND REPAIRS	34		
General Precautions for Removing and Installing Hydraulic System Components	34		

Specifications

Item	Description
Hydrostatic Transmission Maximum Pump Displacement Maximum Pump Flow Rate (98% efficiency @ 3400 RPM) Charge Pump Charge Pump Displacement Charge Pump Flow Rate (60% efficiency @ 3400 RPM) Charge Relief Setting Implement Relief Setting Traction Relief Setting	Sauer–Danfoss (Sundstrand), Variable displacement piston pump, In–Line type Axial Piston Design, Model Series 15 0.913 in ³ /rev (15.0 cm ³ /rev) 13.2 GPM (50.0 LPM) Gerotor Pump in Hydrostat 0.33 in ³ /rev (5.4 cm ³ /rev) 2.9 GPM (11.0 LPM) 135 PSI (9.3 bar) 1100 PSI (75.9 bar) 3200 PSI (220.7 bar) in Forward Direction
Wheel Motors Front Wheel Motor Displacement Rear Wheel Motor Displacement	Orbital rotor motor 17.1 in ³ /rev (280 cm ³ /rev) 8.6 in ³ /rev (141 cm ³ /rev)
Steering Control Valve (Sand Pro 5040 & Infield Pro 5040)	Sauer–Danfoss Steering Unit, Type OSPM
Hydraulic Tank Capacity	5 US gallons (18.9 liters)
Hydraulic Filter	10 Micron (nominal) spin on cartridge type
Hydraulic Oil	See Traction Unit Operator’s Manual

General Information

Hydraulic Hoses

Hydraulic hoses are subject to extreme conditions such as pressure differentials during operation and exposure to weather, sun, chemicals, very warm storage conditions or mishandling during operation or maintenance. These conditions can cause damage or premature deterioration. Some hoses are more susceptible to these conditions than others. Inspect all hydraulic hoses frequently for signs of deterioration or damage.

When replacing a hydraulic hose, be sure that the hose is straight (not twisted) before tightening the fittings. This can be done by observing the imprint on the hose. Use two wrenches; hold the hose in position with one wrench and tighten the hose swivel nut onto the fitting with the second wrench.



WARNING

Before disconnecting or performing any work on hydraulic system, relieve all pressure in system (see Relieving Hydraulic System Pressure). Stop engine and lower or support all attachment(s).

Keep body and hands away from pin hole leaks or nozzles that eject hydraulic fluid under high pressure. Use paper or cardboard, not hands, to search for leaks. Hydraulic fluid escaping under pressure can have sufficient force to penetrate the skin and cause serious injury. If fluid is injected into the skin, it must be surgically removed within a few hours by a doctor familiar with this type of injury. Gangrene may result from such an injury.

Hydraulic Fitting Installation

O-Ring Face Seal

1. Make sure both threads and sealing surfaces are free of burrs, nicks, scratches or any foreign material.
2. Make sure the o-ring is installed and properly seated in the groove. It is recommended that the o-ring be replaced any time the connection is opened.
3. Lubricate the o-ring with a light coating of oil.
4. Put the tube and nut squarely into position on the face seal end of the fitting and tighten the nut until finger tight.
5. Mark the nut and fitting body. Hold the body with a wrench. Use a second wrench to tighten the nut to the correct Flats From Finger Tight (F.F.F.T.). The markings on the nut and fitting body will verify that the connection has been tightened.

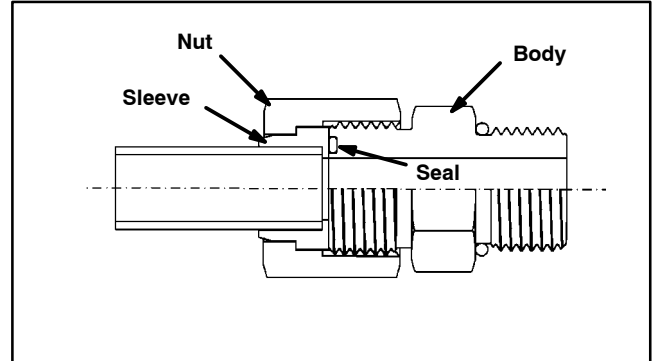

Figure 1

Size	F.F.F.T.
4 (1/4 in. nominal hose or tubing)	0.75 ± 0.25
6 (3/8 in.)	0.75 ± 0.25
8 (1/2 in.)	0.75 ± 0.25
10 (5/8 in.)	1.00 ± 0.25
12 (3/4 in.)	0.75 ± 0.25
16 (1 in.)	0.75 ± 0.25

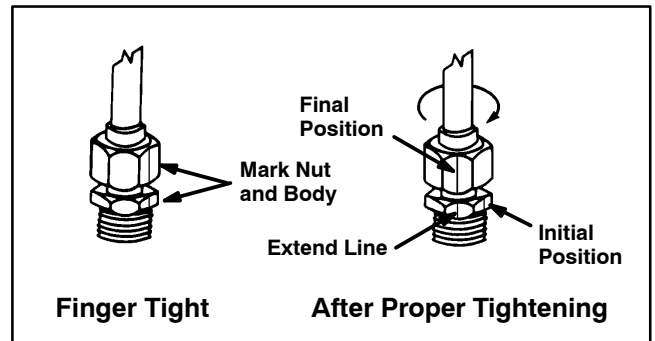

Figure 2

SAE Straight Thread O-Ring Port – Non-Adjustable

1. Make sure both threads and sealing surfaces are free of burrs, nicks, scratches or any foreign material.
2. Always replace the o-ring seal when this type of fitting shows signs of leakage.
3. Lubricate the o-ring with a light coating of oil.
4. Install the fitting into the port and tighten it down full length until finger tight.
5. Tighten the fitting to the correct flats from finger tight (F.F.F.T.).

Size	F.F.F.T.
4 (1/4 in. nominal hose or tubing)	1.00 ± 0.25
6 (3/8 in.)	1.50 ± 0.25
8 (1/2 in.)	1.50 ± 0.25
10 (5/8 in.)	1.50 ± 0.25
12 (3/4 in.)	1.50 ± 0.25
16 (1 in.)	1.50 ± 0.25

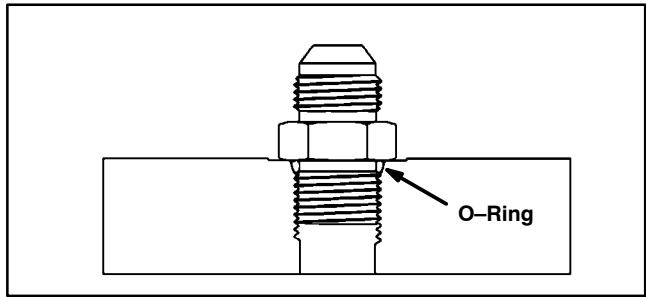

Figure 3

SAE Straight Thread O-Ring Port – Adjustable

1. Make sure both threads and sealing surfaces are free of burrs, nicks, scratches or any foreign material.
2. Always replace the o-ring seal when this type of fitting shows signs of leakage.
3. Lubricate the o-ring with a light coating of oil.
4. Turn back the jam nut as far as possible. Make sure the back up washer is not loose and is pushed up as far as possible (Step 1).
5. Install the fitting into the port and tighten finger tight until the washer contacts the face of the port (Step 2).
6. To put the fitting in the desired position, unscrew it by the required amount, but no more than one full turn (Step 3).
7. Hold the fitting in the desired position with a wrench and turn the jam nut with a second wrench to the correct Flats From Finger Tight (F.F.F.T.) (Step 4).

Size	F.F.F.T.
4 (1/4 in. nominal hose or tubing)	1.00 ± 0.25
6 (3/8 in.)	1.50 ± 0.25
8 (1/2 in.)	1.50 ± 0.25
10 (5/8 in.)	1.50 ± 0.25
12 (3/4 in.)	1.50 ± 0.25
16 (1 in.)	1.50 ± 0.25

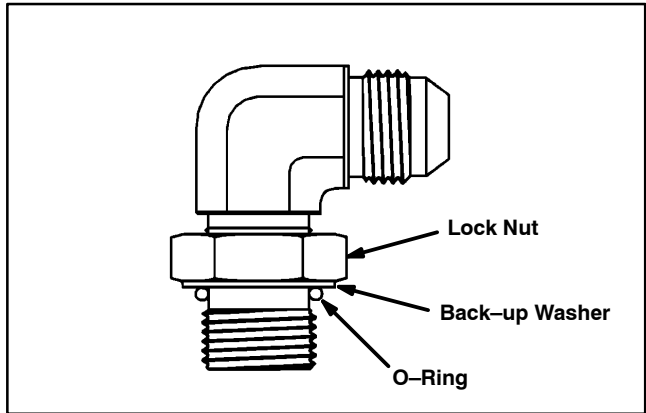

Figure 4

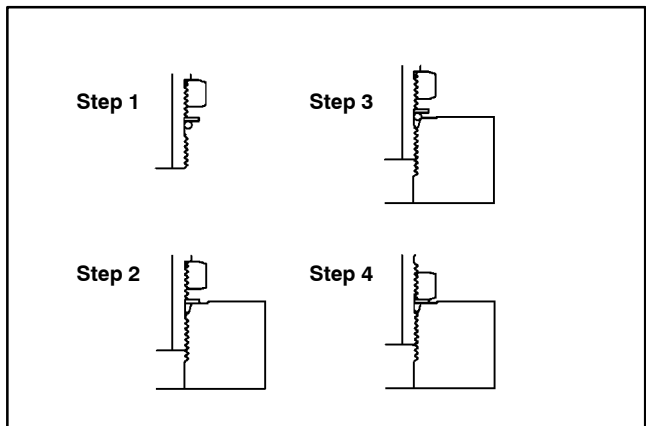

Figure 5

Towing

If it becomes necessary to tow (or push) the machine, tow (or push) at a speed below 1 mph (1.6 kph), and for a very short distance. If machine needs to be moved a considerable distance, machine should be transported on a trailer. Refer to Traction Unit Operator's Manual for Towing Procedures.

IMPORTANT: If towing limits are exceeded, severe damage to the transmission may occur. Also, if machine is towed too fast, wheels may lock up. If wheel lock up occurs, stop towing the machine. Wait for traction circuit pressure to stabilize before resuming towing at a slower speed.

Relieving Hydraulic System Pressure

Before disconnecting or performing any work on the hydraulic system, all pressure in the hydraulic system must be relieved. Park machine on a level surface, lower attachment, turn key switch to OFF and allow engine to stop.

To relieve hydraulic pressure in traction circuit, move traction pedal to both forward and reverse directions. To relieve hydraulic pressure in lift circuit, move lift lever to lower. To relieve hydraulic pressure in Sand Pro 5040 and Infield Pro 5040 steering circuit, rotate steering wheel in both directions.

Traction Circuit Component Failure

The traction circuit on Sand Pro and Infield Pro machines is a closed loop system that includes the hydrostat and three (3) wheel motors. If a component in the traction circuit should fail, debris and contamination from the failed component will circulate throughout the traction circuit. This contamination can damage other components in the circuit so it must be removed to prevent additional component failure.

If a component failure occurs in the traction circuit, it is recommended that the entire traction circuit be disassembled, drained and thoroughly cleaned to ensure that all contamination is removed from the circuit. If any debris remains in the traction circuit and the machine is operated, the debris can cause additional component failure.

An alternative method of removing traction circuit contamination would be to temporarily install a high pressure hydraulic oil filter (see Special Tools) into the circuit. The filter should be used when connecting hydraulic test gauges in order to test traction circuit components or after replacing a failed traction circuit component (e.g. hydrostat or wheel motor). The filter will ensure that contaminants are removed from the closed loop and thus, do not cause additional component damage.

Once the filter has been placed in the circuit, operate the traction circuit to allow oil flow through the circuit. The filter will remove contamination from the traction circuit during circuit operation. The filter can be removed from the machine after contamination has been removed from the traction circuit.

IMPORTANT: When operating the traction system with the high pressure filter installed, make sure that flow is always directed through the filter before entering a replaced component (e.g. do not press the traction pedal in the reverse direction if the filter is placed for forward direction flow). If flow is reversed, debris from the filter will re-enter the traction circuit.

Optional Hydraulic Accessories

Numerous hydraulic accessories are available for Sand Pro and Infield Pro machines. Make sure to retain Installation Instructions, Operator's Manuals and other information if your machine is equipped with any optional hydraulic accessories.

The Hydraulic Schematics section of this chapter includes the hydraulic schematics for the optional remote hydraulics kit and front lift kit.

Hydraulic Schematics

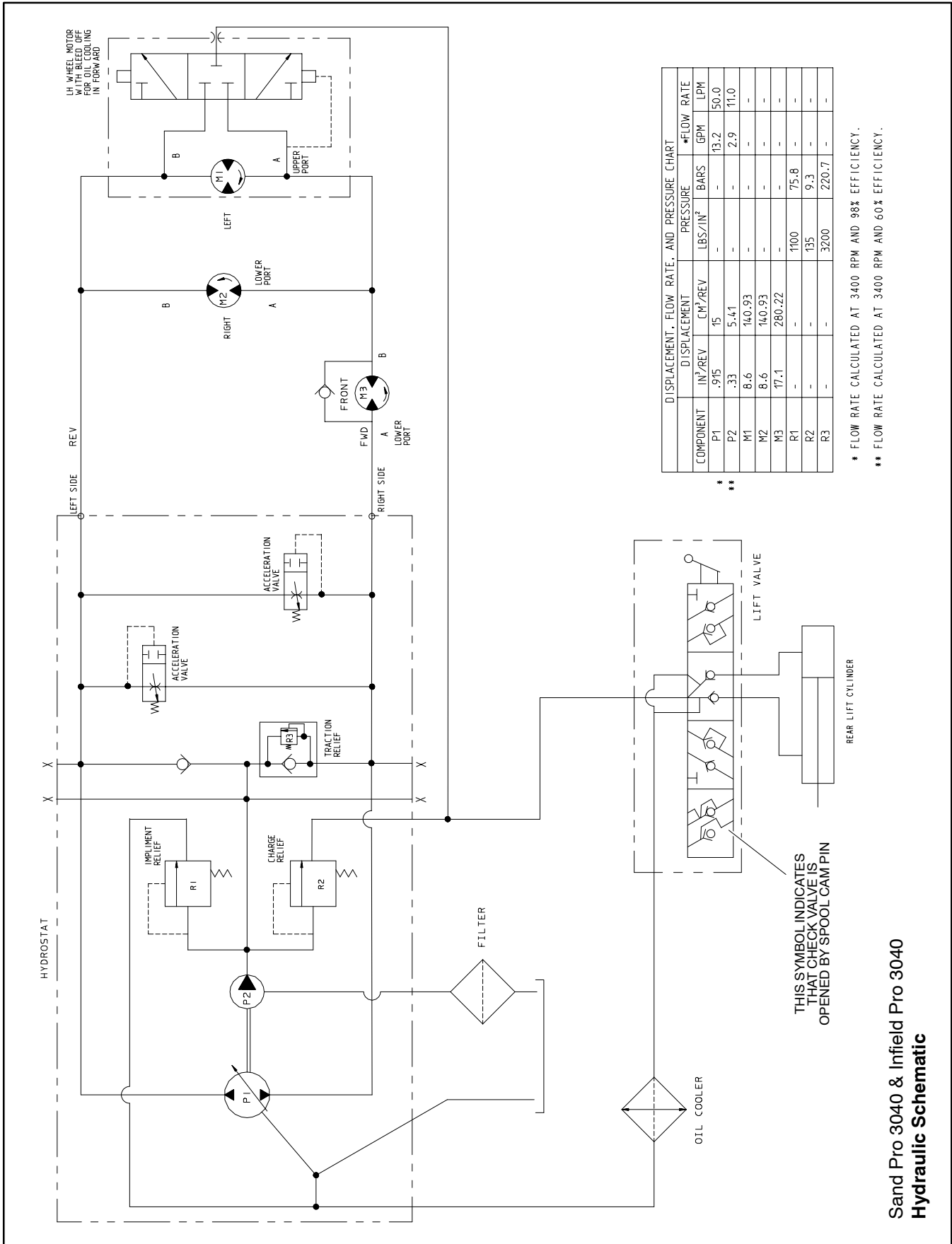

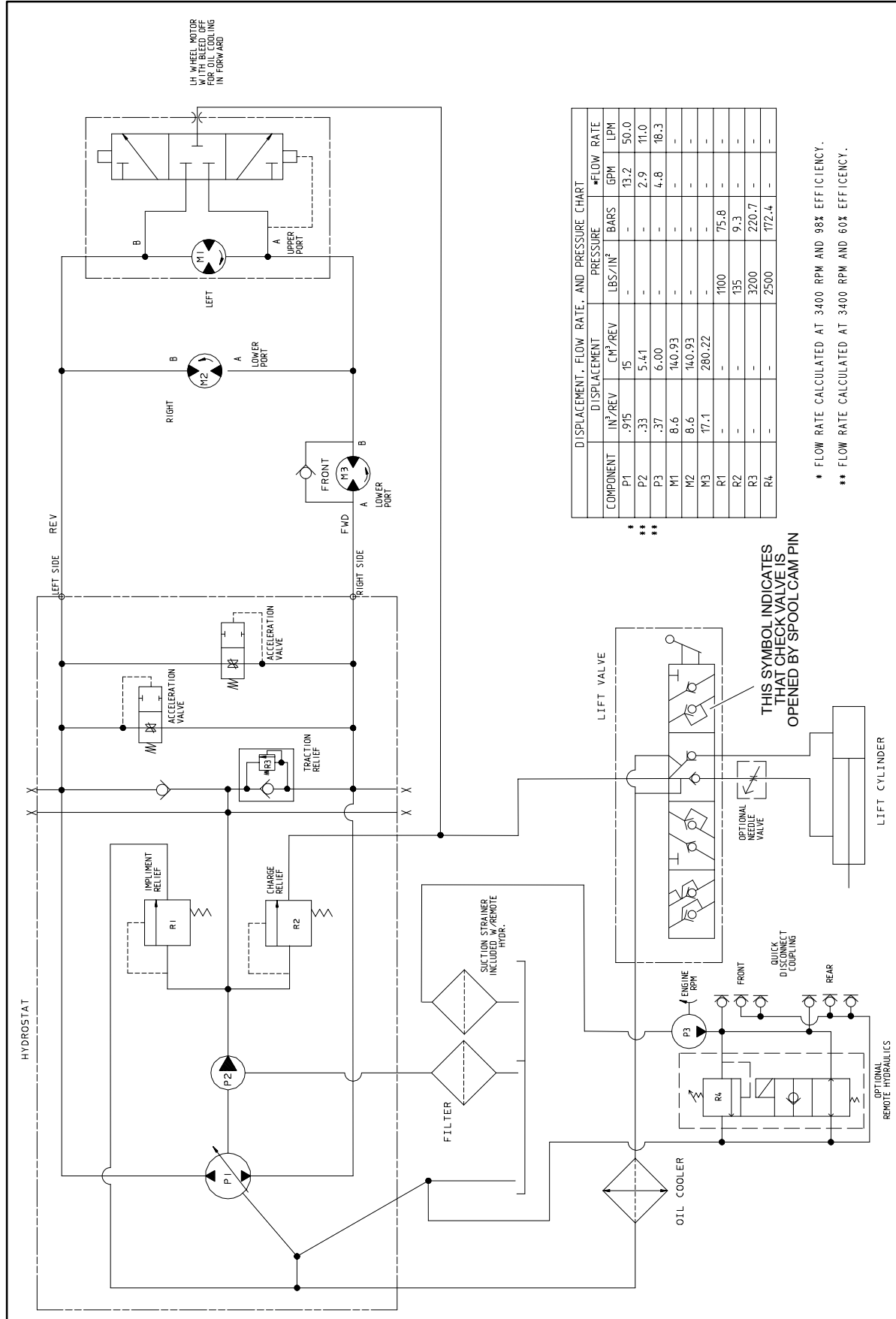

DISPLACEMENT, FLOW RATE, AND PRESSURE CHART

COMPONENT	DISPLACEMENT		PRESSURE		FLOW RATE	
	IN ³ /REV	CM ³ /REV	LBS/IN ²	BAR	GPM	LPM
P1	.915	15	-	-	13.2	50.0
P2	.33	5.41	-	-	2.9	11.0
P3	.37	6.00	-	-	4.8	18.3
M1	8.6	140.93	-	-	-	-
M2	8.6	140.93	-	-	-	-
M3	17.1	280.22	-	-	-	-
R1	-	-	1100	75.8	-	-
R2	-	-	135	9.3	-	-
R3	-	-	3200	220.7	-	-
R4	-	-	2500	172.4	-	-

* FLOW RATE CALCULATED AT 3400 RPM AND 98% EFFICIENCY.
 ** FLOW RATE CALCULATED AT 3400 RPM AND 60% EFFICIENCY.

Sand Pro 3040 & Infield Pro 3040
 (Including Optional Hydraulics Kits)
Hydraulic Schematic

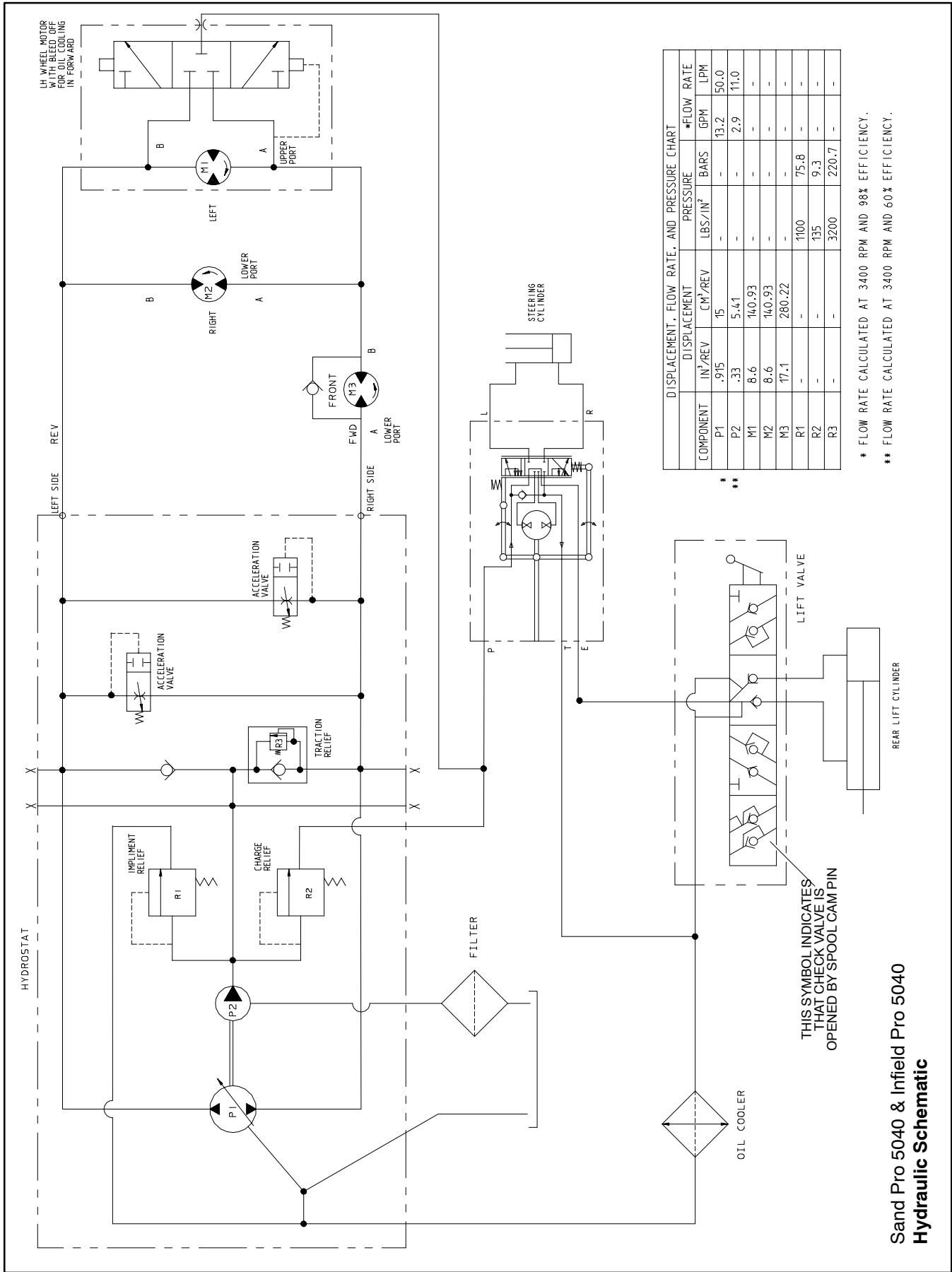

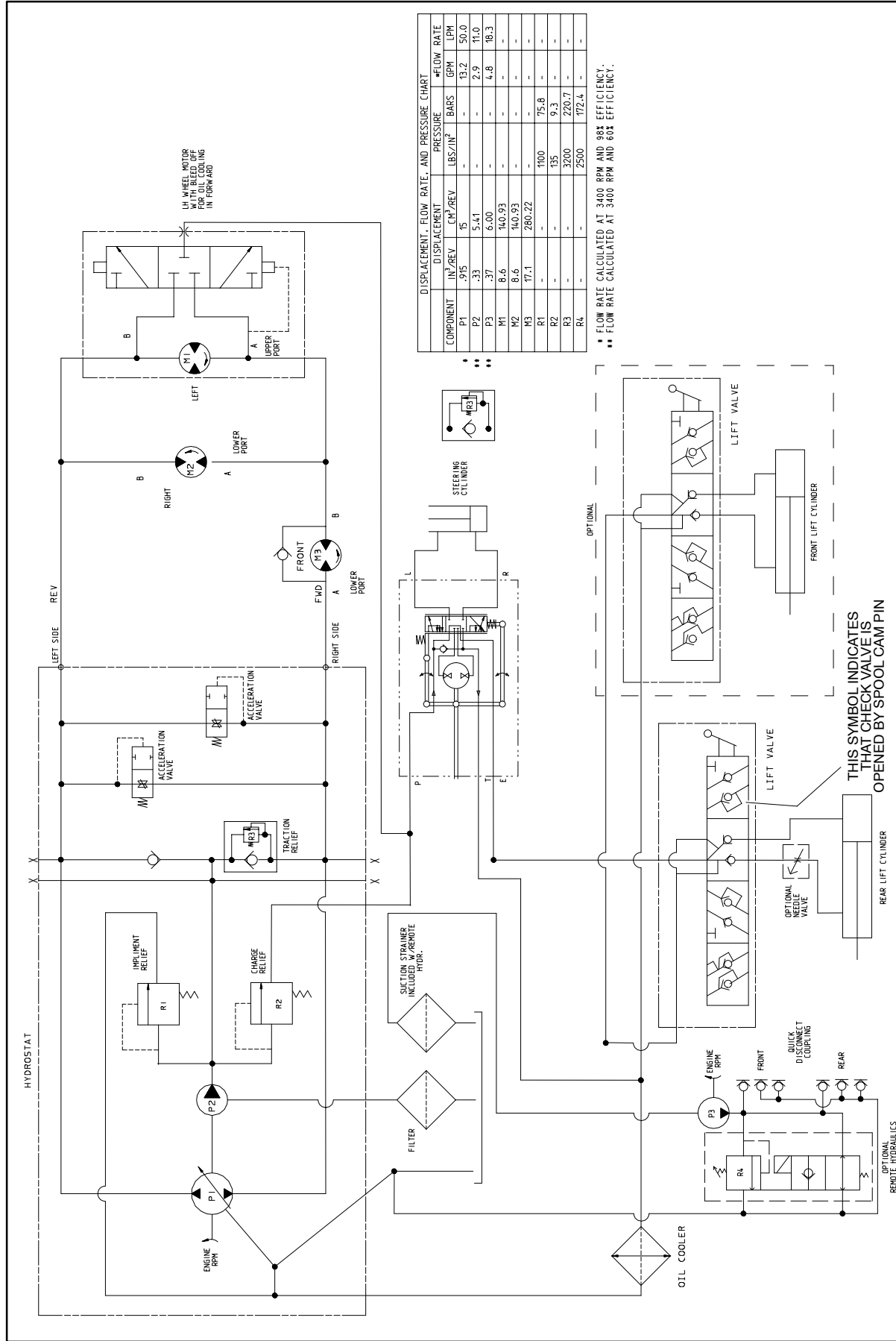

DISPLACEMENT, FLOW RATE, AND PRESSURE CHART

COMPONENT	DISPLACEMENT		PRESSURE		FLOW RATE	
	IN ³ /REV	CM ³ /REV	LBS/IN ²	BARS	GPM	LPM
P1	.915	15	-	-	43.2	50.0
P2	.33	5.41	-	-	2.9	11.0
M1	8-6	140.93	-	-	4.8	18.3
M2	8-6	140.93	-	-	-	-
M3	17-1	280.22	-	-	-	-
R1	-	-	1100	75.8	-	-
R2	-	-	135	9.3	-	-
R3	-	-	3200	220.7	-	-
R4	-	-	2500	172.4	-	-

• FLOW RATE CALCULATED AT 3400 RPM AND 98% EFFICIENCY.
 •• FLOW RATE CALCULATED AT 3400 RPM AND 60% EFFICIENCY.

Sand Pro 5040 & Infield Pro 5040
 (Including Optional Hydraulic Kits)
 Hydraulic Schematic

Hydraulic Flow Diagrams

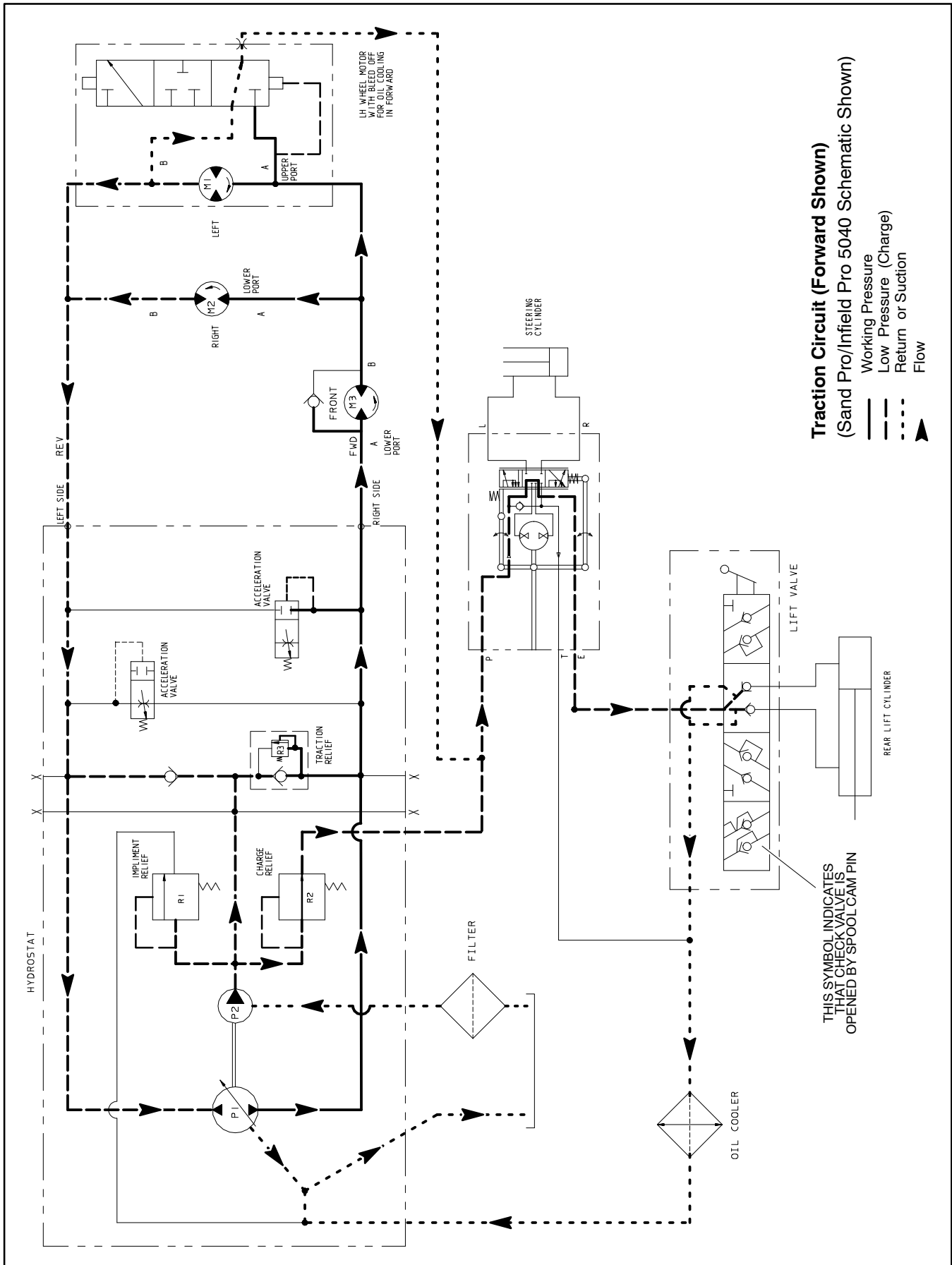

Traction Circuit (Forward Shown)
 (Sand Pro/Infield Pro 5040 Schematic Shown)

- Working Pressure
- - - Low Pressure (Charge)
- · · Return or Suction
- ▶ Flow

THIS SYMBOL INDICATES THAT CHECK VALVE IS OPENED BY SPOOL CAM PIN

Traction Circuit

Forward

The traction circuit of the hydraulic system consists of a hydrostat connected in a closed loop circuit to three orbital vane wheel motors. Hydraulic fluid losses are designed to occur from case drain leakage of the traction pump (P1) and bleed off from the left rear wheel motor (M1). These losses are replenished by the charge pump (P2), which is integral to the hydrostat.

The engine drives traction pump (P1) directly through a coupling. The traction pump is a variable displacement piston pump. The traction pedal connects through a linkage to the trunnion shaft and swash plate of the pump. With the engine running and the traction pedal in the neutral position, P1 supplies no flow to the wheel motors. When the traction pedal is pressed to the forward position, the linkage from the pedal positions the swash plate in the traction pump so oil flows out port B (right side of pump). Oil flow out of port B goes to the wheel motors and turns them in the forward direction. The oil flow goes through the front motor first and then through the left and right rear wheel motors. Oil flowing out of the rear wheel motors returns to port A (left side of pump) of the hydrostat and is continuously pumped out of port B. Traction relief valve (R3) limits forward traction circuit pressure to 3200 PSI (220.7 bar).

The hydrostat uses a small amount of hydraulic fluid for internal lubrication. Fluid is designed to leak across pump parts into the case drain. This leakage results in the loss of hydraulic fluid from the closed loop traction circuit that must be replenished.

The charge pump (P2) is a fixed displacement gerotor pump. It is driven directly off the traction pump. The charge pump replenishes the closed loop traction circuit with hydraulic fluid from the tank. The charge relief valve (R2) supplies sufficient head so that charge pump flow is guided to the low pressure side of the traction circuit through one of two check valves. Charge pump flow in excess of traction circuit replenishment requirements is used for the lift circuit and steering circuit on Sand Pro 5040 and Infield Pro 5040 machines.

The left rear wheel motor bleeds off a small amount of hydraulic fluid for cooling of the closed loop traction circuit. This bleed off happens in the forward direction only. The high pressure side of the motor forces a shuttle spool to shift against a spring. The pressure drop across the motor causes a small amount of fluid to bleed off through a fixed orifice on the low pressure side of the motor and then through the shuttle spool. This bleed off returns to the tank through the lift circuit and oil cooler.

The front wheel motor has a check valve across its ports that allows the motor to over run during tight turns in the forward direction.

The acceleration valves in the hydrostat reduce the rate of change in acceleration (jerkiness) when hydrostat output is increased by the action of the operator. An increase of pressure on the output side of the hydrostat will by-pass some pump flow to the low pressure side of the pump. The valve on the high pressure side closes at a predetermined rate as pressure increases. This gives the hydrostat a smooth acceleration rate when the swashplate is stroked rapidly.

Reverse

The traction circuit operates essentially the same in reverse as it does in forward. However, there are a few differences in operation.

When the traction pedal is pressed to the reverse position, the linkage from the pedal positions the traction pump swash plate so oil flows out of port A (left side of pump). Oil flow out of port A goes to the wheel motors and turns them in the reverse direction. The oil flow goes through the left and right rear wheel motors first and then is directed to the front wheel motor. Oil by-passes the front motor in reverse because of the check valve inside the motor. Oil flowing out of the front wheel motor returns to port B (right side of pump) of the hydrostat and is continuously pumped out of port A.

The left rear wheel motor **does not** bleed off any hydraulic fluid for cooling of the closed loop traction circuit in the reverse direction.

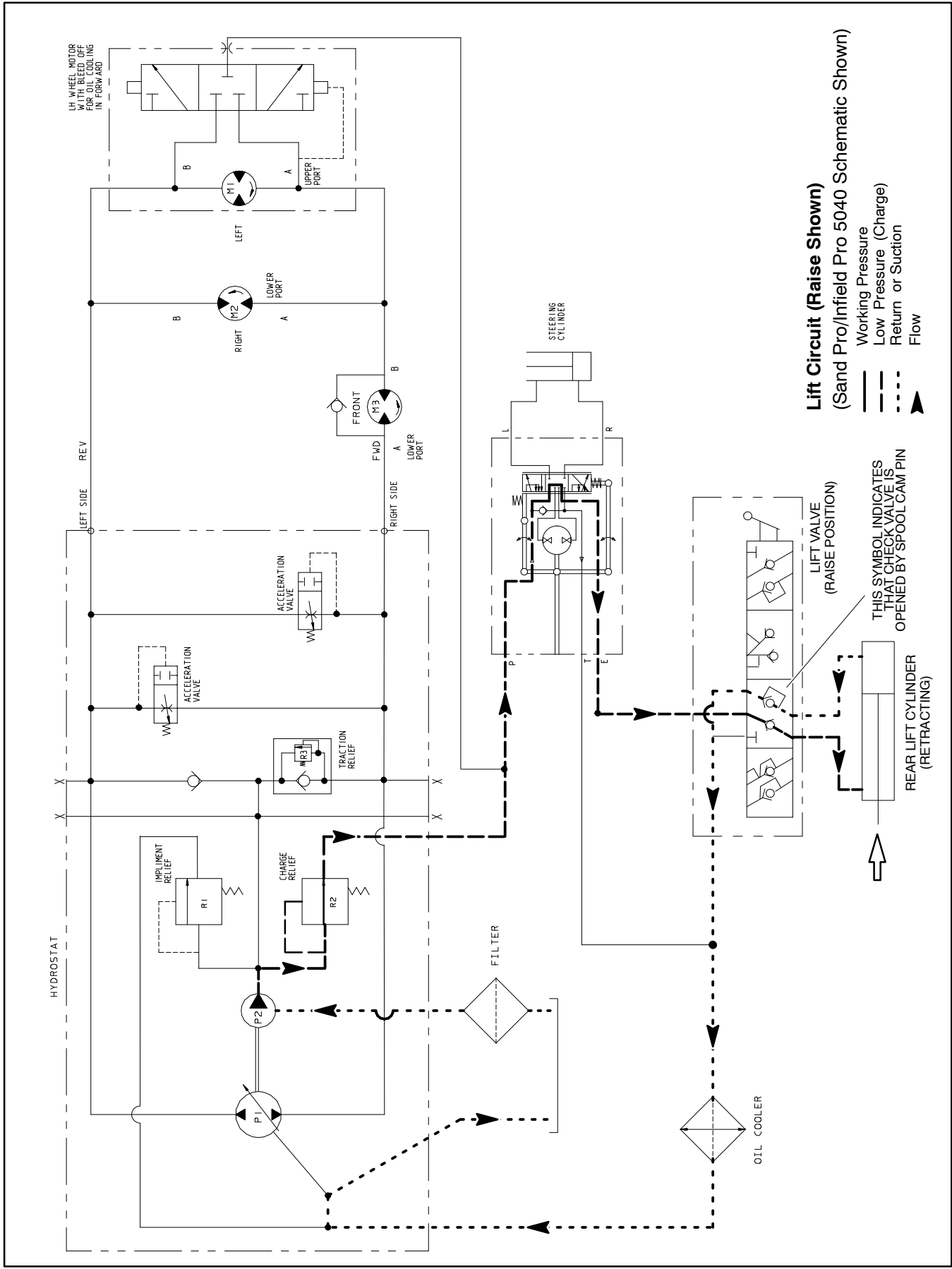

Lift Circuit

In addition to replenishing the closed loop traction circuit with hydraulic oil from the tank, charge pump (P2) supplies flow for the implement lift circuit and the steering circuit on Sand Pro 5040 and Infield Pro 5040 machines. Lift and steering circuit pressure is limited to 1100 PSI (75.9 bar) by the implement relief valve (R1) located in the hydrostat. On Sand Pro 5040 and Infield Pro 5040 machines, pump (P2) output flows to the steering control valve before reaching the lift valve so the steering circuit has priority.

The charge pump (P2) is a fixed displacement gerotor pump that is driven directly off the traction pump (P1). It has sufficient output to handle intermittent operation of the lift cylinder under load. The implement relief valve (R1) in the charge circuit allows high enough pressure (1100 PSI / 75.9 bar) to operate the lift cylinder with attachments, and protects the charge pump while using the lift circuit to raise or lower the attachment.

When the lift control valve is in the neutral position, fluid flow from the charge pump is bypassed around the lift cylinder through the lift valve. Fluid returns to the tank as a normal part of the charge and bleed off circuits.

Moving the lift lever to the raise position allows the lift control valve to direct fluid flow from the charge pump to the rod side of the lift cylinder. The piston moves into the cylinder pushing fluid out the piston end of the cylinder and to the tank. As the cylinder rod retracts, the attachment is raised. When the lift lever is released, the lift valve returns to the neutral position and the attachment is held in position.

Moving the lift lever to the lower position allows the lift control valve to direct fluid flow from the charge pump to the piston side of the lift cylinder (Fig. 6). The piston moves out of the cylinder pushing fluid out the rod end of the cylinder and to the tank. As the cylinder rod extends, the attachment is lowered. When the lift lever is released, the lift valve returns to the neutral position and the attachment is held in position.

An adjustable detent plate allows the lift lever to be placed in a float position. When in float, the lift control valve allows the attachment to follow ground contours during operation (Fig. 6).

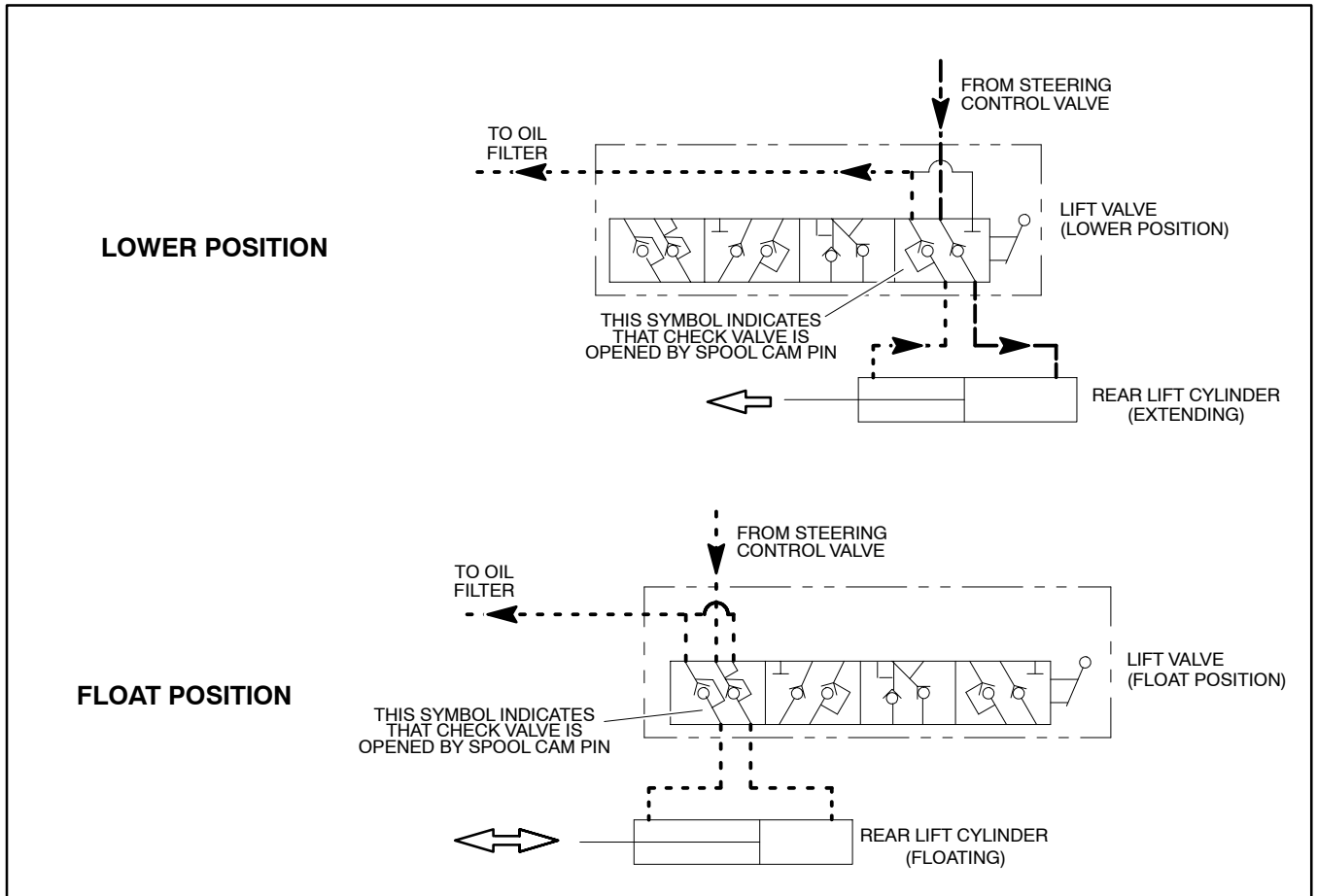
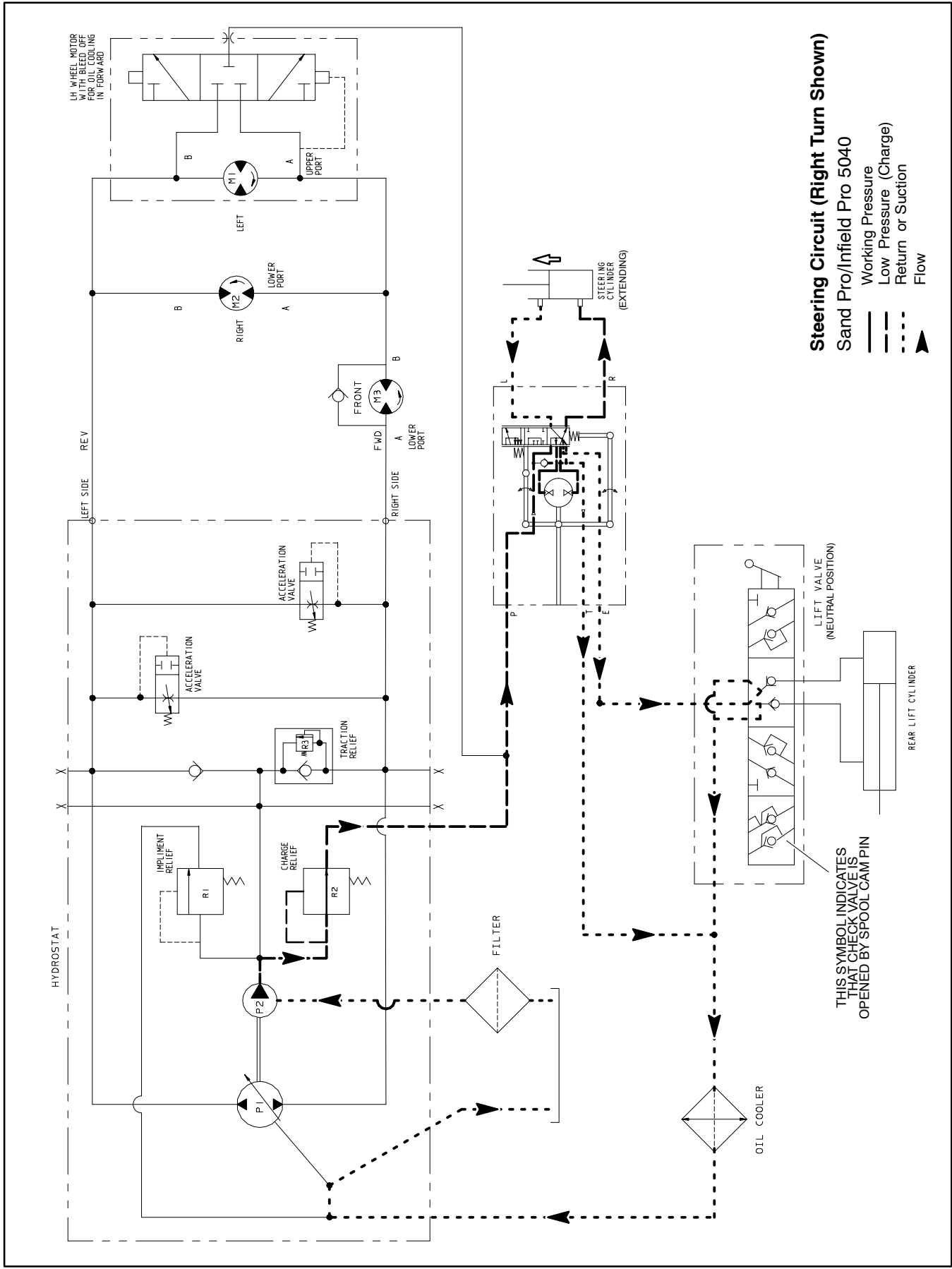

Figure 6



Steering Circuit (Right Turn Shown)
 Sand Pro/Infield Pro 5040
 Working Pressure
 Low Pressure (Charge)
 Return or Suction
 Flow

Steering Circuit (Sand Pro 5040 and Infield Pro 5040)

The charge pump in the hydrostat on Sand Pro 5040 and Infield Pro 5040 machines supplies flow for the steering circuit and for the implement lift circuit. Pump output flows to the steering control valve before reaching the lift control valve so the steering circuit has priority. Steering circuit pressure is limited to 1100 PSI (75.9 bar) by the implement relief valve (R1) located in the hydrostat.

When the steering wheel is not being turned and the engine is running (hydrostat input shaft being rotated), charge pump flow enters the steering control valve at the P port and by-passes the rotary meter and steering cylinder. Flow leaves the steering control valve through the E port and is directed to the lift control valve.

Right Turn

When a right turn is made with the engine running, the turning of the steering wheel positions the steering control spool valve so that flow goes through the bottom of the spool. Flow entering the steering control valve at the P port passes through the rotary meter and is directed out the R port. Pressure extends the steering cylinder for a right turn. The rotary meter ensures that the oil flow to the cylinder is proportional to the amount of the turning on the steering wheel. Fluid leaving the steering cylinder flows back through the spool valve, then out the T port of the steering control valve and to the hydraulic tank.

P port passes through the rotary meter and is directed out port R. Pressure extends the steering cylinder for a right turn. The rotary meter ensures that the oil flow to the cylinder is proportional to the amount of the turning on the steering wheel. Fluid leaving the cylinder flows back through the spool valve, then out the T port of the steering control valve and to the hydraulic tank.

Left Turn

When a left turn is made with the engine running, the turning of the steering wheel positions the steering control spool valve so that flow goes through the top of the spool. Flow entering the steering control valve at the P port passes through the rotary meter and is directed out the L port. Pressure retracts the steering cylinder for a left turn. The rotary meter ensures that the oil flow to the cylinder is proportional to the amount of the turning on the steering wheel. Fluid leaving the steering cylinder flows back through the spool valve, then out the T port of the steering control valve and returns to the hydraulic tank.

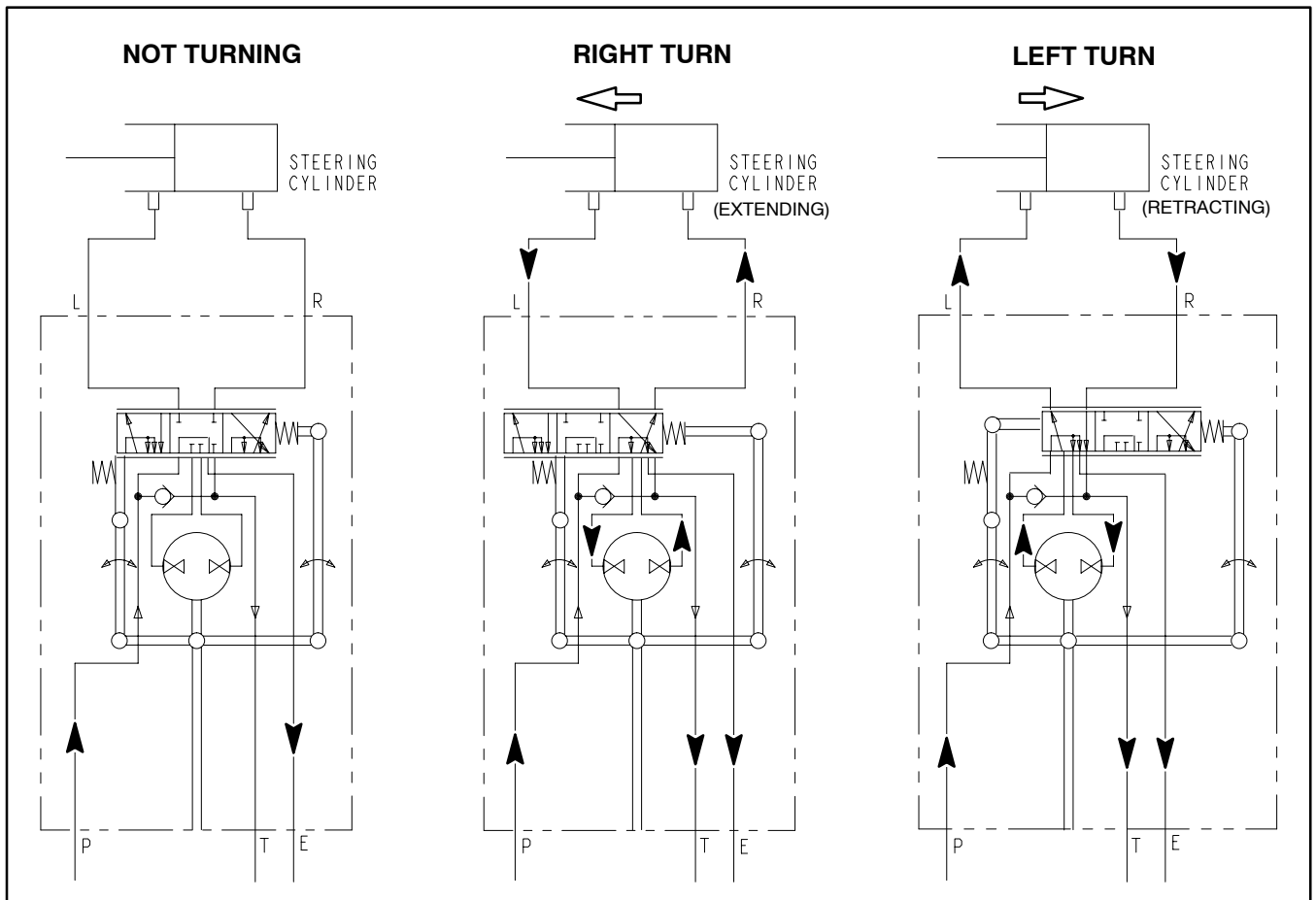

Figure 7

Special Tools

Order these tools from the *TORO SPECIAL TOOLS AND APPLICATIONS GUIDE (COMMERCIAL PRODUCTS)*.

Hydraulic Pressure Test Kit

Part Number: **TOR47009**

Use to take various pressure readings for diagnostic tests. Quick disconnect fittings provided attach directly to mating fittings on machine test ports without tools. A high pressure hose is provided for remote readings. The Pressure Test Kit contains one each: 1000 PSI (70 Bar), 5000 PSI (350 Bar) and 10000 PSI (700 Bar) gauges. Use gauges as recommended in the Testing Section of this chapter.



Figure 8

Hydraulic Tester (Pressure and Flow)

Part Number: **TOR214678**

This tester requires o-ring face seal (ORFS) adapter fittings for use on this machine.

1. **INLET HOSE:** Hose connected from the system circuit to the inlet side of the hydraulic tester.
2. **LOAD VALVE:** A simulated working load is created in the circuit by turning the valve to restrict flow.
3. **LOW PRESSURE GAUGE:** Low range gauge to provide accurate reading at low pressure: 0 to 1000 PSI (0 to 70 Bar).

A protector valve cuts out when pressure is about to exceed the normal range for the gauge. The cutout pressure is adjustable.

4. **HIGH PRESSURE GAUGE:** High range gauge which accommodates pressures beyond the capacity of the low pressure gauge: 0 to 5000 PSI (0 to 350 Bar).
5. **FLOW METER:** This meter measures actual oil flow in the operating circuit with a gauge rated at 15 GPM.
6. **OUTLET HOSE:** A hose from the outlet side of the hydraulic tester connects to the hydraulic system circuit.



Figure 9

Hydraulic Test Fitting Kit

Part Number: **TOR4079**

The test fitting kit includes a variety of O-ring Face Seal fittings to enable the connection of test gauges into the system.

The kit includes: tee's, unions, reducers, plugs, caps and male test fittings.







TORO TEST FITTING KIT (TOR4079)			
FITTING	TOOL NUMBER	FITTING	TOOL NUMBER
	Swivel Nut Run Tee (2 ea.) Size Toro No. No. 4 TOR4079-3 No. 8 TOR4079-12 No. 8 TOR4079-4 No. 10 TOR4079-5		Union (1 ea.) Size Toro No. No. 8 to No. 8 TOR4079-8 No. 10 to No. 8 TOR4079-2 No. 8 to No. 8 TOR4079-9
	Plug (2 ea.) Size Toro No. No. 4 TOR4079-13 No. 8 TOR4079-14 No. 8 TOR4079-15 No. 10 TOR4079-16		Reducer (1 ea.) Size Toro No. No. 10 to No. 8 TOR4079-7 No. 12 to No. 8 TOR4079-6
	Cap (2 ea.) Size Toro No. No. 4 TOR4079-17 No. 8 TOR4079-18 No. 8 TOR4079-19 No. 10 TOR4079-20		Test Cap Fitting (2 ea.) Size Toro No. No. 4 TOR4079-10 No. 8 TOR4079-11 No. 8 TOR4079-21 No. 10 TOR4079-1
			Test Fitting (2 ea.) Size Toro No. 7/16-20 ORB TOR4079-22 1/8" Pipe Thd. TOR4079-23

Figure 10

Measuring Container

Part Number: **TOR4077**

Use this graduated container for doing hydraulic motor efficiency testing (motors with case drain lines only). Measure efficiency of a hydraulic motor by restricting the outlet flow from the motor and measuring leakage from the case drain line while the motor is pressurized by the hydraulic system.

The table in Figure 12 provides gallons per minute (GPM) conversion for measured milliliter or ounce leakage.



Figure 11

GPM	Milliliters in 15 sec.	Ounces in 15 sec.
.1	95	3.2
.2	189	6.4
.3	284	9.6
.4	378	12.8
.5	473	16.0
.6	568	19.2
.7	662	22.4
.8	756	25.6
.9	852	28.8
1.0	946	32.0

Figure 12

O-Ring Kit

Part Number: **16-3799**

The o-ring kit includes o-rings in a variety of sizes for face seal and port seal hydraulic connections. It is recommended that o-rings be replaced whenever a hydraulic connection is loosened.



Figure 13

Wheel Hub Puller

Part Number: **TOR4097**

The wheel hub puller allows safe removal of the wheel hub from the shaft of hydraulic wheel motors.



Figure 14

High Pressure Hydraulic Oil Filter

If a component failure occurs in the closed loop traction circuit, contamination from the failed part will remain in the circuit until removed. When connecting hydraulic test gauges in order to test traction circuit components or after replacing a failed traction circuit component (e.g. hydrostat or wheel motor), a high pressure hydraulic filter can be installed in the traction circuit. The filter will ensure that contaminants are removed from the closed loop and thus, do not cause additional component damage.

A high pressure hydraulic oil filter can be obtained locally.



Figure 15

Troubleshooting

The chart that follows contains information to assist in troubleshooting. There may possibly be more than one cause for a machine malfunction.

Refer to the Testing section of this Chapter for precautions and specific hydraulic test procedures.

NOTE: See Sauer–Danfoss (Sundstrand) 15 Series Service Manual and Sauer–Danfoss Steering Unit Type OSPM Service Manual (Sand Pro 5040 and Infield Pro 5040) at the end of this chapter for additional troubleshooting information regarding the hydraulic system.

Problem	Possible Cause
Hydraulic oil leaks from system.	Fitting(s), hose(s) or tube(s) are loose or damaged. O–ring(s) or seal(s) are missing or damaged.
Hydraulic fluid foams.	Hydraulic oil level in tank is low. Hydraulic system is contaminated with water. Hydraulic system has wrong type of oil. The pump suction line has an air leak.
Hydraulic system operates hot.	Hydraulic oil level in tank is low. Transmission pressure is high due to excessive traction load. Hydraulic oil is contaminated or oil viscosity is too light. Oil cooler is damaged or plugged. Hydraulic oil filter is plugged. Charge pump (P2) pressure is low. Charge check valve in hydrostat is stuck or faulty. Accelerator valves in hydrostat are faulty. Shuttle valve in LH rear wheel motor is stuck or faulty. Wheel motor(s) is (are) worn or damaged. Charge pump (P2) is worn or damaged. Hydrostat is worn or damaged.
Neutral is difficult to find or unit operates in one direction only.	External pump control linkage is misadjusted, disconnected, binding or damaged. Charge check valve in hydrostat is stuck or faulty. Acceleration valves in hydrostat are faulty. Hydrostat is worn or damaged.

Problem	Possible Cause
Traction response is sluggish.	Hydraulic oil is very cold. External pump control linkage is misadjusted, disconnected, binding or damaged. Charge pump (P2) pressure is low. Accelerator valves in hydrostat are faulty. Hydrostat and/or wheel motor(s) is/are worn or damaged.
No traction movement exists in either direction.	Parking brake is applied. Hydraulic oil level in tank is low. External pump control linkage is misadjusted, disconnected, binding or damaged. Hydrostat coupler is damaged. Charge pump (P2) pressure is low. Accelerator valves in hydrostat are faulty. Charge check valves in hydrostat are stuck or damaged. Charge pump is worn or damaged. Hydrostat and/or wheel motor(s) is/are worn or damaged.
Wheel motor will not turn.	Parking brake is applied. Wheel motor is damaged.
Wheel motor will not hold load in neutral.	Make up fluid from charge pump is not available. Hydrostat check valves are faulty or damaged.
Attachment will not lift or lifts slowly.	Engine speed is too low. Lift cylinder linkage is binding or broken. Lift arm bushings are binding. Hydraulic oil level in tank is low. Charge pump (P2) pressure or flow is insufficient. Charge pump (P2) is worn or damaged. Implement relief valve (R1) is stuck open. Lift cylinder leaks internally. Lift control valve is defective.
Attachment raises, but will not stay up.	Lift cylinder leaks internally. Check valve within the lift control valve leaks.
Turning steering wheel turns machine in the opposite direction (Sand Pro 5040 and Infield Pro 5040).	Hoses to the steering cylinder are reversed.

Testing

The most effective method for isolating problems in the hydraulic system is by using hydraulic test equipment such as pressure gauges and flow meters in the circuits during various operational checks (see the Special Tools section in this Chapter).

Before Performing Hydraulic Tests

IMPORTANT: All obvious areas such as oil supply, oil filter, binding linkages, loose fasteners or improper adjustments must be checked before assuming that a hydraulic component is the source of a hydraulic system problem.

Precautions for Hydraulic Testing

	CAUTION
Failure to use gauges with expected pressure (psi) rating as listed in test procedures could result in damage to the gauge and possible personal injury from leaking hot oil.	

	CAUTION
All testing should be performed by two (2) people. One person should be in the seat to operate the machine and the other should read and record test results.	

	WARNING
Keep body and hands away from pin hole leaks or nozzles that eject hydraulic fluid under high pressure. Do not use hands to search for leaks; use paper or cardboard. Hydraulic fluid escaping under pressure can have sufficient force to penetrate the skin and cause serious injury. If fluid is injected into the skin, it must be surgically removed within a few hours by a doctor familiar with this type of injury. Gangrene may result from such an injury.	

1. Clean machine thoroughly before disconnecting or disassembling any hydraulic components. Always keep in mind the need for cleanliness when working on hydraulic equipment. Contamination can cause excessive wear or binding of hydraulic components.

2. Review all test steps before starting the test procedure.

3. Before testing, check all control linkages for improper adjustment, binding or broken parts.

4. All hydraulic tests should be made with the hydraulic oil at normal operating temperature.

	WARNING
Before disconnecting or performing any work on the hydraulic system, all pressure in the system must be relieved. See Relieving Hydraulic System Pressure in the General Information section.	

5. Put metal caps or plugs on any hydraulic lines left open or exposed during testing or component removal.

6. When using hydraulic tester (pressure and flow), the inlet and the outlet hoses must be properly connected and not reversed to prevent damage to the hydraulic tester or components.

7. Install hydraulic fittings finger tight and far enough to make sure that they are not cross-threaded before tightening them with a wrench.

8. Position tester hoses to prevent rotating machine parts from contacting and damaging the hoses or tester.

9. After connecting test equipment, check oil level in the hydraulic tank to make sure that oil level is correct.

10. When using hydraulic tester (pressure and flow), open tester load valve completely before starting engine to minimize the possibility of damaging components.

11. The engine must be in good operating condition. Use a phototac when performing a hydraulic test. Engine speed can affect the accuracy of the tester readings. Check actual speed of the pump when performing hydraulic flow tests.

12. If a traction circuit problem exists, consider performing one or more of the following tests: Charge Relief Valve (R2) Pressure, Traction Relief Valve (R3) Pressure, Traction Pump (P1) Flow, Charge Pump (P2) Flow and/or Wheel Motor Efficiency Tests.

13. If a lift or steering (Sand Pro 5040 and Infield Pro 5040) circuit problem exists, consider performing one or more of the following tests: Implement Relief Valve (R1) Pressure, Charge Pump (P2) Flow and/or Steering Cylinder Internal Leakage Tests.

Charge Pressure and Implement Relief Valve (R1) Pressure Tests

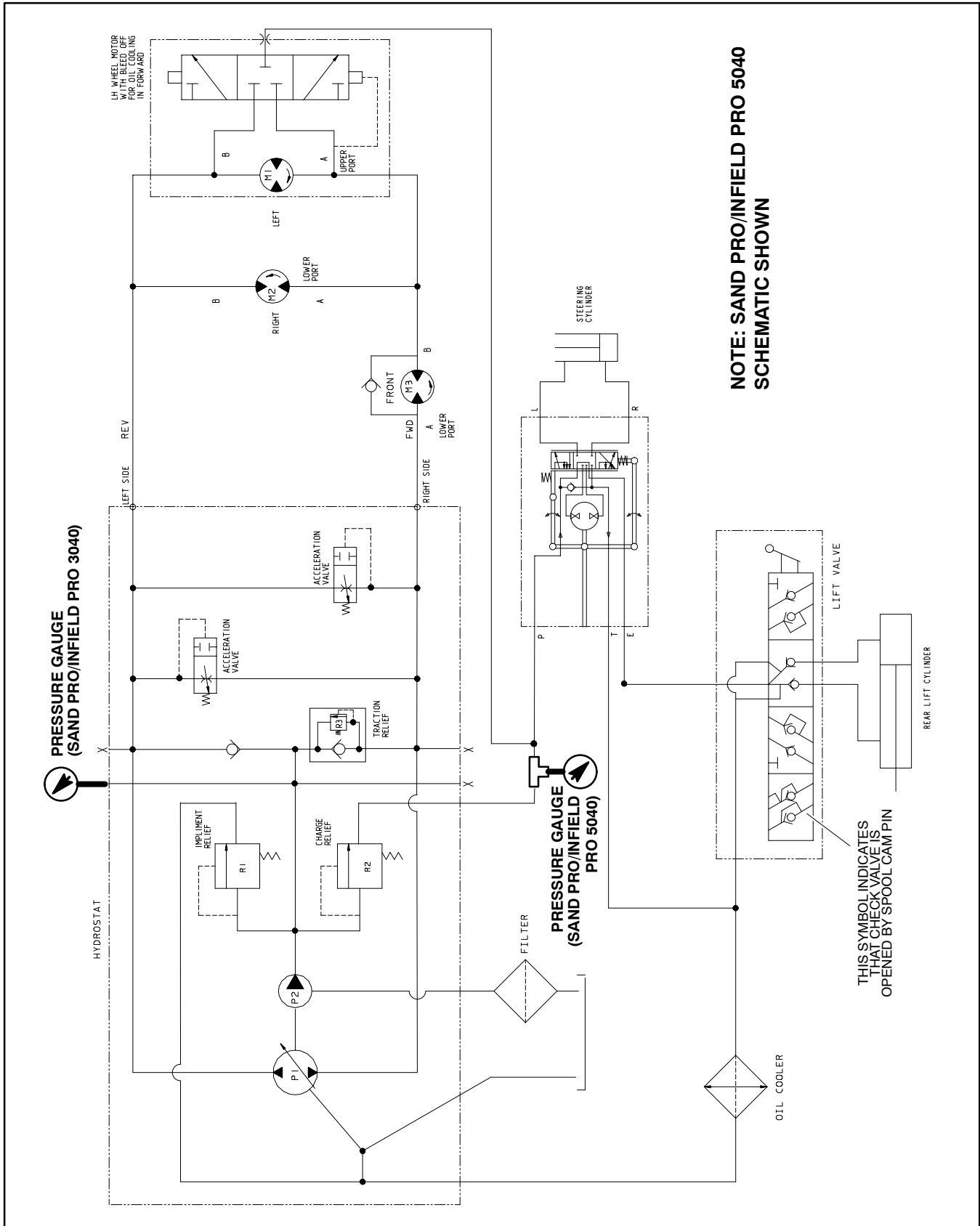

Figure 16

Procedure for Charge Pressure and Implement Relief Valve (R1) Pressure Tests:

1. Make sure hydraulic oil is at normal operating temperature by operating the machine for approximately 10 minutes.
2. Park machine on a level surface with the attachment lowered. Make sure engine is off and that the parking brake is applied.
3. Read and follow Precautions for Hydraulic Testing.

IMPORTANT: Make sure to thoroughly clean around all hydraulic connections that will be disassembled.

4. Install pressure gauge to machine:
 - A. For Sand Pro 3040 and Infield Pro 3040 machines, remove plug from one of the hydrostat charge test ports (Fig. 17). Install pressure gauge to test port.
 - B. For Sand Pro 5040 and Infield Pro 5040 machines, install a tee connector with pressure gauge in series between the tee fitting on the lower right side of the hydrostat and the hydraulic hose from the hydrostat (Fig. 18).

5. Make sure that traction pedal and lift control lever are in neutral and the parking brake is applied.
6. Start engine and run at low idle speed. Check for hydraulic leakage and correct before proceeding with test.
7. Operate engine at full speed (**3400 RPM**). Verify pump hub speed with a phototac.

8. The pressure gauge will display system charge pressure and should read as follows. Record test results.

- A. For Sand Pro 3040 and Infield Pro 3040 machines, charge pressure should be from **120 to 330 PSI (8.3 to 22.7 bar)**.
- B. For Sand Pro 5040 and Infield Pro 5040 machines, charge pressure should be from **70 to 330 PSI (4.8 to 22.7 bar)**.

NOTE: If machine is equipped with optional front lift, charge pressure will increase approximately 50 PSI (3.5 bar).

IMPORTANT: DO NOT hold system at implement relief for more than a few seconds.

9. With the engine still running at full speed (**3400 RPM**), move lift lever to the lower position. Hold lift lever in the lower position to allow the implement relief valve to activate. The pressure gauge will display implement relief pressure and should read as follows. After noting pressure, return lift lever to neutral position.

Sand Pro & Infield Pro 3040/5040

A. For Sand Pro 3040 and Infield Pro 3040 machines, measured implement relief pressure should be from **900 to 1100 PSI (62.1 to 75.9 bar)**.

B. For Sand Pro 5040 and Infield Pro 5040 machines, measured implement relief pressure should be from **780 to 980 PSI (53.8 to 67.6 bar)**.

10. Shut off engine and record test results.

11. If charge pressure specification is not met, inspect, repair or replace charge relief valve (R2). If implement relief specification is not met, inspect, repair or replace implement relief valve (R1). See Sauer-Danfoss (Sundstrand) 15 Series Service Manual at the end of this chapter for relief valve service information.

12. Remove pressure gauge. On Sand Pro 3040 and Infield Pro 3040 machines, install and tighten hydrostat test port plug. On Sand Pro 5040 and Infield Pro 5040 machines, reconnect hydraulic hose to hydrostat tee fitting.

13. Make sure hydraulic tank is full (see Operator's Manual).

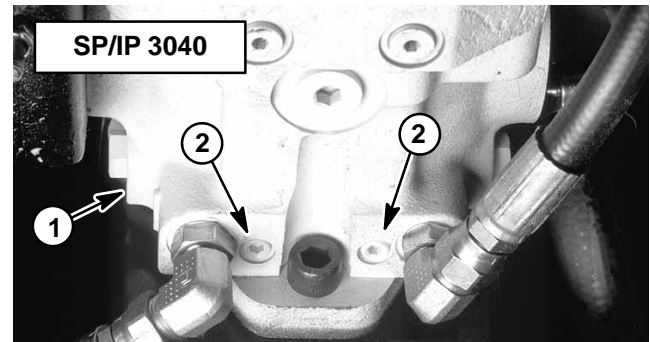

Figure 17

1. Hydrostat (from below)
2. Charge test port

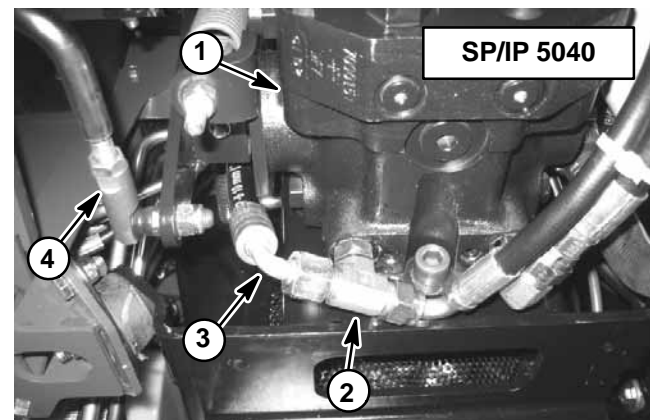

Figure 18

1. Hydrostat (from below)
2. Hydrostat tee fitting
3. Hydraulic hose
4. Traction rod

Traction Relief Valve (R3) Pressure Test

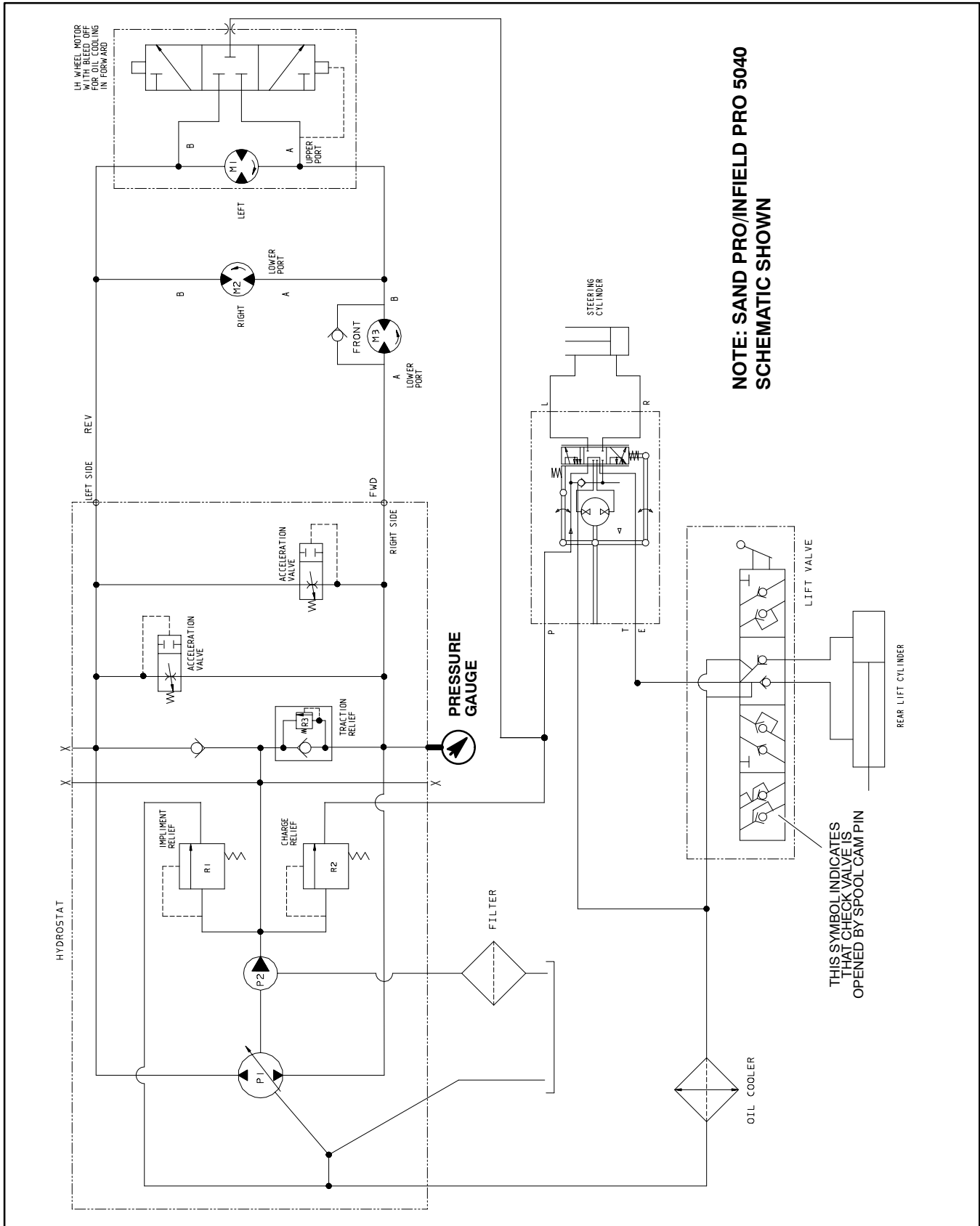

Figure 19

Procedure for Traction Relief Valve (R3) Pressure Test:

1. Make sure hydraulic oil is at normal operating temperature by operating the machine for approximately 10 minutes.
2. Park machine on a level surface with the attachment removed. Make sure engine is off and that the parking brake is applied.
3. Read and follow Precautions for Hydraulic Testing.
4. Make sure that traction pedal is adjusted to the neutral position (see Operator's Manual).

IMPORTANT: Make sure to thoroughly clean around all hydraulic connections that will be disassembled.

5. Determine the hydrostat charge pressure by performing the Charge Relief Valve (R2) Pressure Test.
6. Remove plug from forward traction port on bottom of hydrostat (Fig. 20). Install pressure gauge to test port.
7. After installing pressure gauge, start engine and run at low idle speed. Check for hydraulic leakage and correct before proceeding with test.
8. Operate engine at full speed (**3400 RPM**).



CAUTION

Use extreme caution when taking gauge readings. The front wheel will be turning.

9. Sit in the operator seat, make sure that the parking brake is applied and slowly push traction pedal in the **forward** direction. Depress traction pedal to between 1/3 and 1/2 of pedal travel. Engine speed should decrease to approximately 2800 RPM as pedal is depressed.

IMPORTANT: DO NOT hold system at relief for more than a few seconds.

IMPORTANT: DO NOT allow pressure to exceed 4000 PSI (275.8 bar) during testing.

10. While depressing traction pedal, watch the pressure gauge and record pressure when the traction circuit relief valve opens.

11. Pressure gauge reading should be at least **3200 PSI (220.7 bar) higher than charge pressure**. Record test results.

Example: Consider a machine that has a charge pressure of 240 PSI (16.6 bar). The traction relief pressure for this machine should be at least 3440 PSI (237.3 bar).

12. Release traction pedal and turn engine off.

NOTE: If the relief pressure cannot be obtained and engine speed drops excessively (below 2800 RPM) as the traction pedal is depressed, engine performance should be evaluated (see Chapter 3 – Gasoline Engine).

13. If traction relief pressure is incorrect, inspect traction relief valve (R3) in hydrostat (see the Sauer–Danfoss (Sundstrand) 15 Series Service Manual at the end of this chapter). Clean or replace relief valve as needed. If relief valve is in good condition, acceleration valves and charge check valve in hydrostat should be inspected as well. A worn or damaged hydrostat could be considered if relief, check and acceleration valves are in good condition.

14. If traction relief pressure is correct and a traction circuit problem exists, check traction pump (P1) flow (see Traction Pump (P1) Flow Test in this section) and wheel motor efficiency (see Wheel Motor Efficiency Test in this section).

15. When testing is complete, remove hydraulic pressure gauge from machine and install plug into hydrostat port.

16. Make sure hydraulic tank is full (see Operator's Manual).

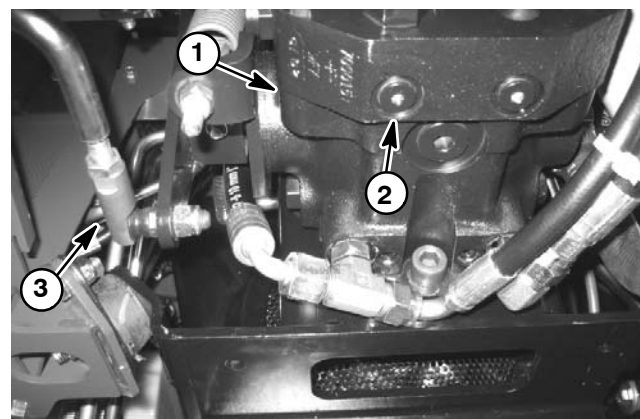

Figure 20

1. Hydrostat (from below)
2. Forward traction port
3. Traction rod

Traction Pump (P1) Flow Test

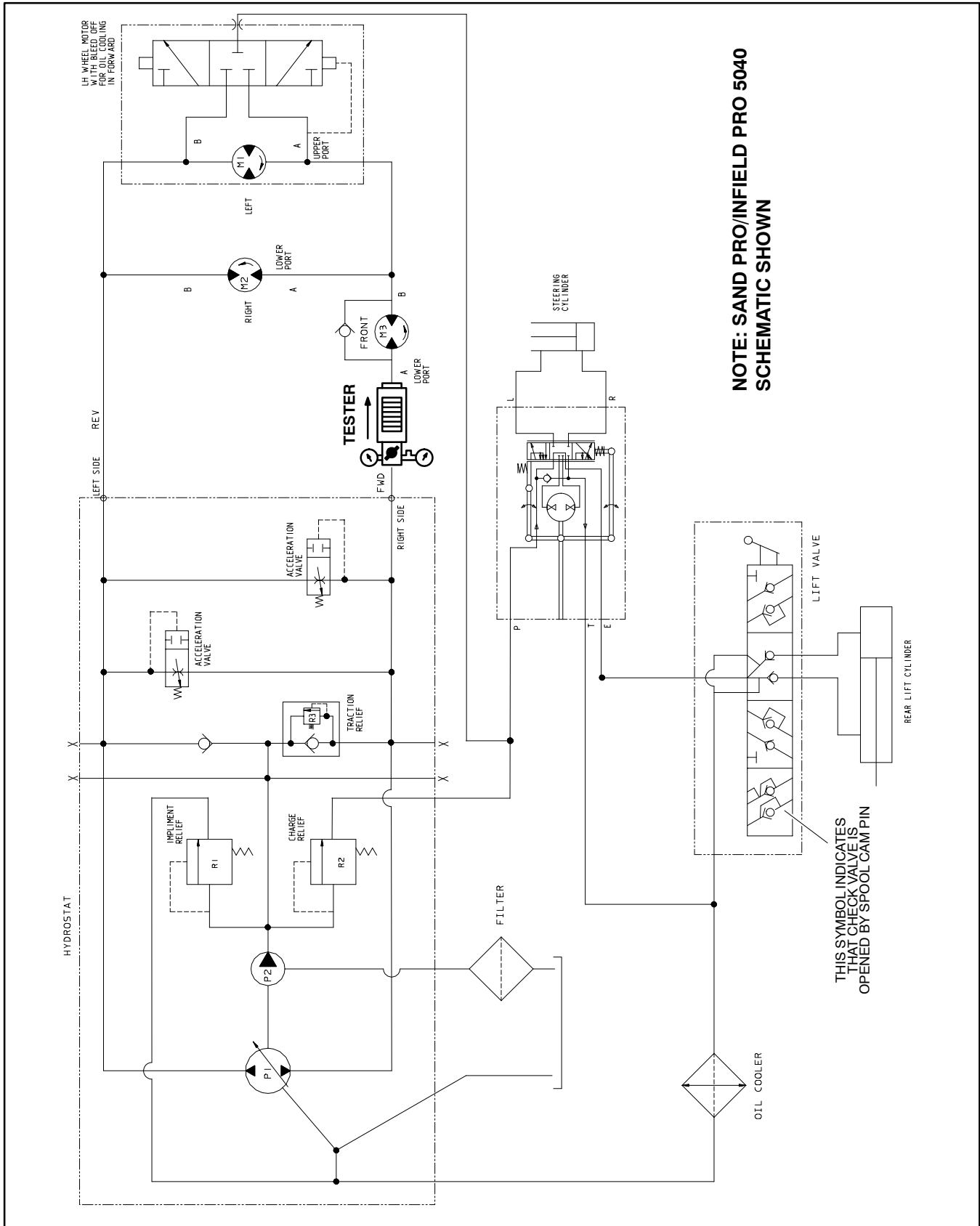

Figure 21

Procedure for Traction Pump (P1) Flow Test:

1. Make sure hydraulic oil is at normal operating temperature by operating the machine for approximately 10 minutes.
2. Park machine on a level surface with the attachment removed. Make sure engine is off.
3. Read and follow Precautions for Hydraulic Testing.
4. Make sure that traction pedal is adjusted to the neutral position and that traction pedal allows full stroke of the pump lever (see Operator's Manual).



WARNING

Before jacking up the machine, review and follow Jacking Instructions in Chapter 1 – Safety.

5. Jack up and support machine with blocks or jack stands so that all three wheels are off the ground. In this test, the wheels need to spin freely to allow hydraulic flow through the traction circuit. Make sure that the parking brake is **not** applied.

IMPORTANT: Make sure to thoroughly clean around all hydraulic connections that will be disassembled.

6. Disconnect hydraulic hose from hydraulic tube leading to the front wheel motor lower port to allow hydraulic tester (flow meter) installation (Fig. 22).
7. Install hydraulic tester (flow meter) between disconnected hose and tube. Make sure that tester flow arrow points from the hose and into the tube. **Make sure the flow control valve on the tester is fully open.**
8. After installing hydraulic tester, start engine and run at low idle speed. Check for hydraulic leakage and correct before proceeding with test.
9. Operate engine at full speed (**3400 RPM**).



CAUTION

Use extreme caution when taking gauge readings. The wheels off the ground will be spinning.

10. Sit in the operator seat and slowly push traction pedal to the full **forward** position.

11. While holding the traction pedal in full forward, slowly close flow control valve on tester until pressure gauge on tester reads **1300 PSI (89.6 bar)**. As the flow control valve is being closed, engine speed should decrease to approximately **2800 RPM** (verify engine speed with a phototac).

12. Observe flow gauge. Tester reading should be approximately **10 GPM (37.9 LPM)**. Record test results.

13. Release traction pedal, open flow control valve on tester and turn engine off.

14. If **1300 PSI (tester pressure)**, **2800 RPM (engine speed)** or **10 GPM flow** cannot be achieved, consider the following:
 - A. The traction pedal and traction speed may need adjustment (see Operator's Manual).
 - B. If the engine speed drops excessively (below 2800 RPM) as the tester flow control valve is closed, engine performance should be evaluated (see Chapter 3 – Gasoline Engine).
 - C. If engine speed does not drop and pressure and flow specifications are not met, the hydrostat needs to be repaired or replaced as necessary.

15. If specifications are met and a traction circuit problem exists, check wheel motor efficiency (see Wheel Motor Efficiency Test in this section).

16. When testing is complete, lower wheels to the ground. Remove hydraulic tester and reconnect hydraulic hose to hydraulic tube.

17. Make sure hydraulic tank is full (see Operator's Manual).

18. When testing is complete, lower wheels to the ground. Remove hydraulic tester and reconnect hydraulic hose to hydraulic tube.

19. Make sure hydraulic tank is full (see Operator's Manual).

20. Make sure hydraulic tank is full (see Operator's Manual).

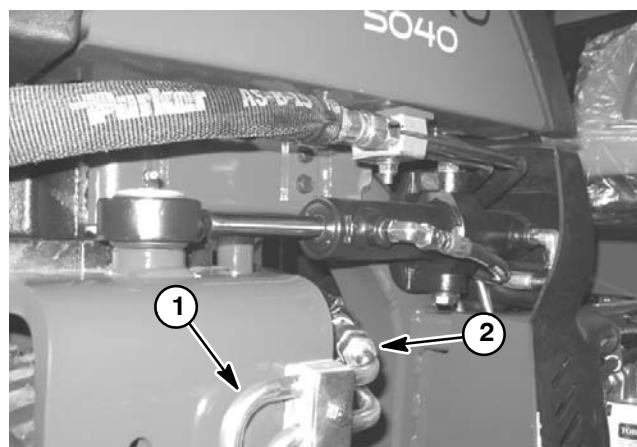

Figure 22

1. Tube to lower motor port
2. Hydraulic hose

Wheel Motor Efficiency Test

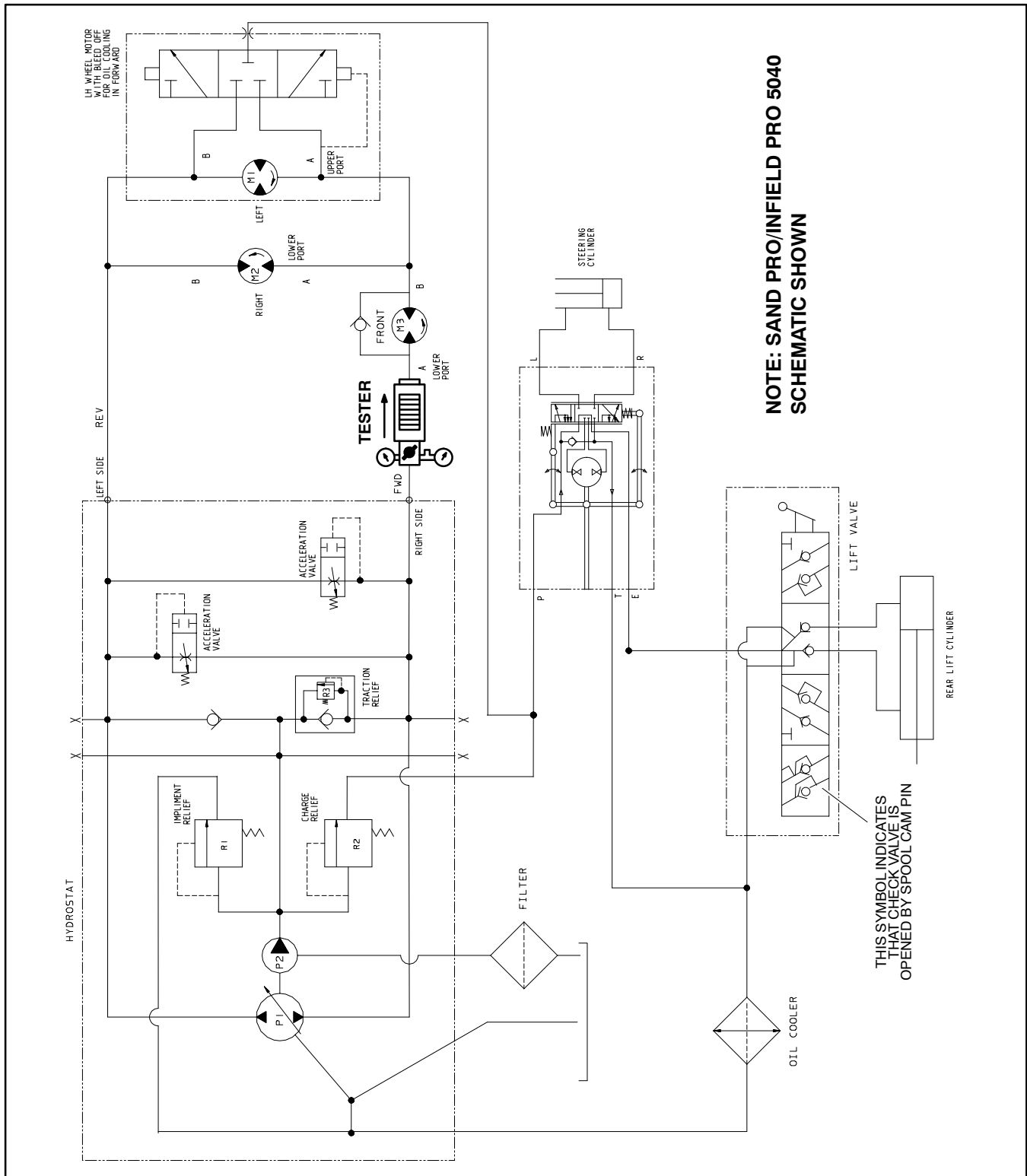

Figure 23

NOTE: Over a period of time, a wheel motor can wear internally. A worn motor may by-pass oil causing the motor to be less efficient. Eventually, enough oil loss will cause the wheel motor to stall under heavy load condi-

tions. Continued operation with a worn, inefficient motor can generate excessive heat, cause damage to seals and other components in the hydraulic system and affect overall machine performance.

Procedure for Wheel Motor Efficiency Test:

1. Make sure hydraulic oil is at normal operating temperature by operating the machine for approximately 10 minutes. Make sure the hydraulic tank is full.
2. Park machine on a level surface with the attachment lowered. Make sure engine is off and the parking brake is engaged.
3. Read Precautions for Hydraulic Testing.
4. Make sure that traction pedal is adjusted to the neutral position (see Operator's Manual).

IMPORTANT: Make sure to thoroughly clean around all hydraulic connections that will be disassembled.

5. Install hydraulic tester (flow meter) using the same tester connections as Traction Pump (P1) Flow Test. **Make sure the tester flow control valve is fully open.**
6. After installing hydraulic tester, start engine and run at low idle speed. Check for hydraulic leakage and correct before proceeding with test.
7. Make sure parking brake is engaged. Chock the front wheel to prevent front wheel rotation.



8. Move throttle to full speed (**3400 RPM**).
9. Sit in the operator seat and slowly push traction pedal in the **forward** direction until **1000 PSI (69.0 bar)** is displayed on the tester pressure gauge.
10. With all drive wheels locked (not rotating), total internal leakage for all wheel motors will be shown on the flow meter. Flow should be **less than 2 GPM (7.6 LPM)**. Record test results.
11. Release traction pedal, shut engine off, rotate wheels and retest. Testing of wheel motor leakage in three different wheel positions will provide the most accurate test results.
12. If specification is not met, individual wheel motors need to be removed from the traction circuit to determine which motor(s) is leaking excessively.

A. The front motor can be removed from the traction circuit by disconnecting the hydraulic hose from the hydraulic tube leading to the front wheel motor upper port. Disconnect tester hose from hydraulic tube leading to the front wheel motor lower port. Then, to allow flow to the rear wheels, connect the flow meter hose to the disconnected hydraulic hose.

B. A rear motor can be removed from the traction circuit by disconnecting and capping the two hydraulic lines at the motor.

13. After removing a motor from the circuit, retest using steps 6 through 10 making sure that the remaining drive wheels are locked (not rotating) during testing. Test wheel motor leakage in three different wheel positions for accurate test results. When a worn motor is removed from the traction circuit, the test results should show a decrease in leakage flow from the system. Any wheel motor that has leakage **greater than .7 GPM (2.6 LPM)** needs to be repaired or replaced.

Example: Consider a machine that has a total wheel motor internal leakage of 3.5 GPM (13.2 LPM). When the right, rear wheel motor is removed from the traction circuit, the system leakage decreases to 1 GPM (3.8 LPM). The leakage for the disconnected motor is 2.5 GPM (9.5 LPM) which indicates the need to repair or replace the right, rear wheel motor.

Multiple wheel motors may be worn, so efficiency testing of all wheel motors may be required. After an individual motor is tested, reconnect that motor before proceeding to test another motor.

14. After testing is completed, disconnect tester from machine and reconnect all hydraulic lines.

15. Make sure hydraulic tank is full (see Operator's Manual).

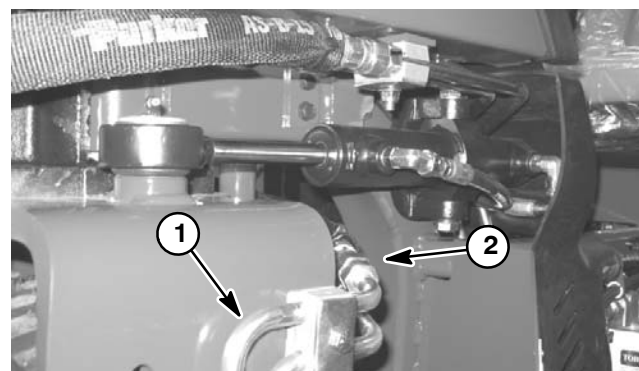

Figure 24

1. Tube to lower motor port
2. Hydraulic hose

Charge Pump (P2) Flow Test

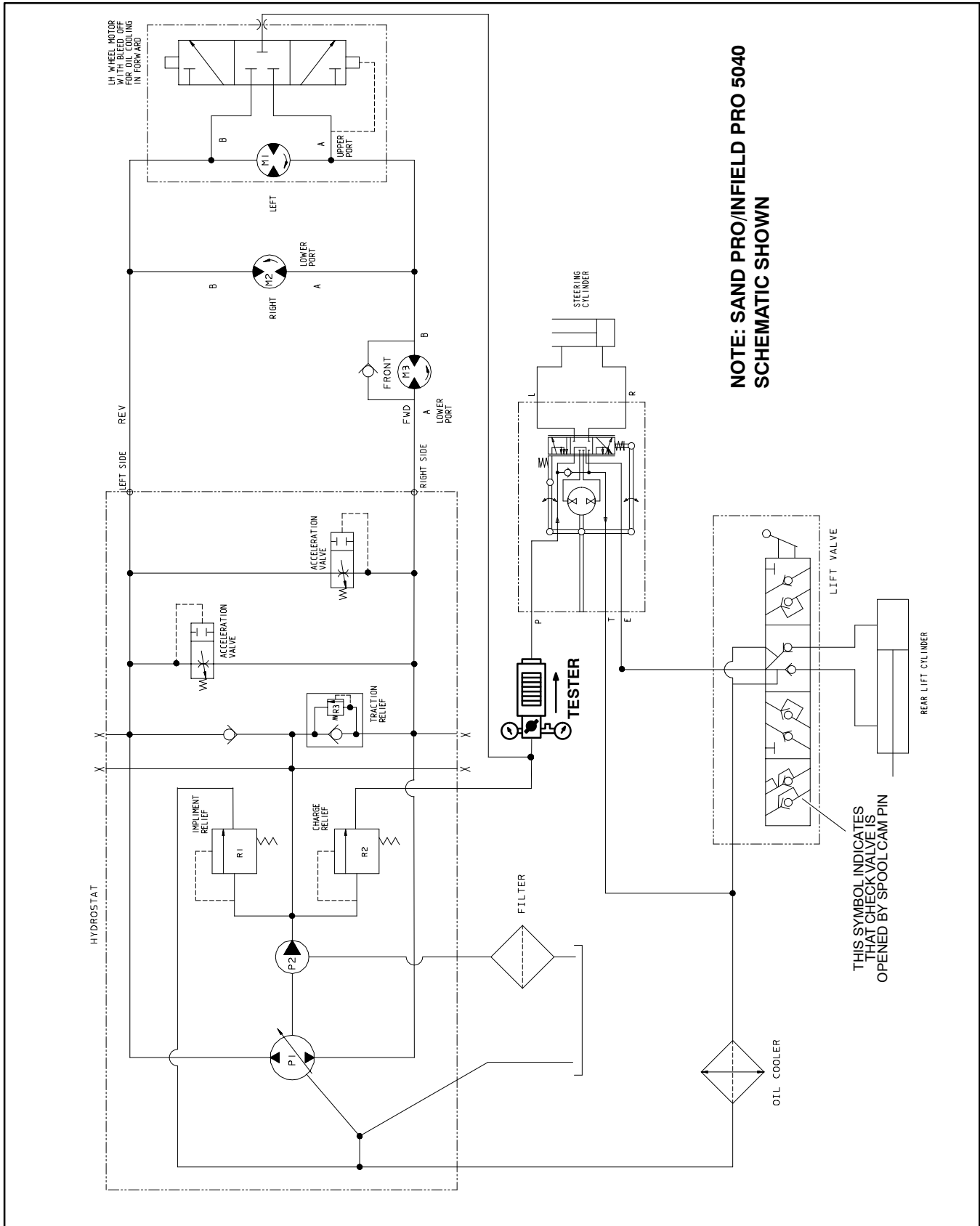

Figure 25

Procedure for Charge Pump (P2) Flow Test:

1. Make sure hydraulic oil is at normal operating temperature by operating the machine for approximately 10 minutes.
2. Park machine on a level surface with the attachment lowered. Make sure engine is off and that the parking brake is applied.
3. Read and follow Precautions for Hydraulic Testing.
4. Make sure that traction pedal is adjusted to the neutral position (see Operator's Manual).

IMPORTANT: Make sure to thoroughly clean around all hydraulic connections that will be disassembled.

5. Disconnect hydraulic hose from the fitting on the lower right side of the hydrostat (Fig. 26 or 27).
6. Install hydraulic tester (flow meter) in series with the disconnected hose and the fitting on the hydrostat. Make sure the tester flow arrow points away from the hydrostat. **Make sure the flow control valve on the tester is fully open.**
7. Make sure that traction pedal and lift control lever are in neutral and the parking brake is applied.
8. Start engine and run at low idle speed. Check for hydraulic leakage and correct before proceeding with test.
9. Operate engine at full speed (**3400 RPM**).
10. Slowly close the flow control valve on the tester until **500 PSI (34.5 bar)** is obtained.
11. Using a phototac, verify that pump hub speed is **3400 RPM**.
12. Flow indication on tester should be a minimum of **2 GPM (7.6 LPM)**. Record test results.
13. Open the flow control valve on the tester and shut off engine.
14. If flow is less than **2 GPM (7.6 LPM)** or **500 PSI (34.5 bar)** can not be obtained, check for restrictions in the pump circuit. If pump circuit is not restricted, repair or replace charge pump (see Sauer-Danfoss (Sundstrand) 15 Series Service Manual at the end of this chapter).
15. Disconnect tester from the hydraulic hose and hydrostat fitting. Reconnect hose to fitting (Fig. 26).
16. Make sure hydraulic tank is full (see Operator's Manual).

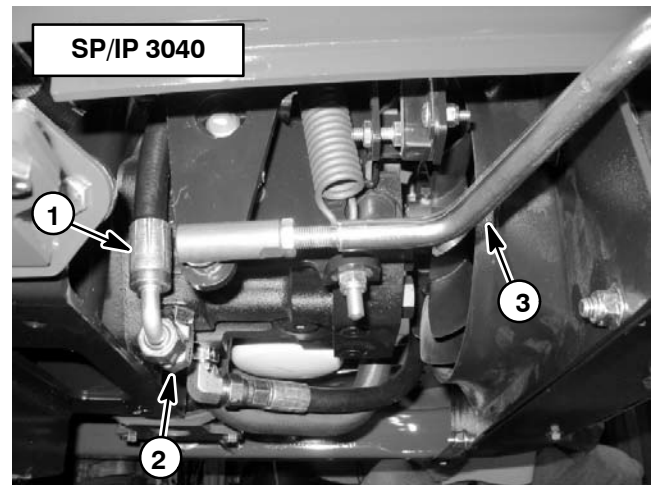

Figure 26

- | | |
|----------------------|-----------------|
| 1. Hydraulic hose | 3. Traction rod |
| 2. Hydrostat fitting | |

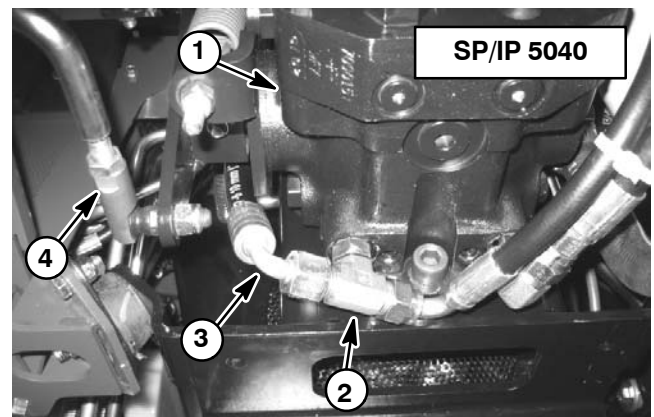

Figure 27

- | | |
|---------------------------|-------------------|
| 1. Hydrostat (from below) | 3. Hydraulic hose |
| 2. Hydrostat tee fitting | 4. Traction rod |

Steering Cylinder Internal Leakage Test (Sand Pro 5040 and Infield Pro 5040)

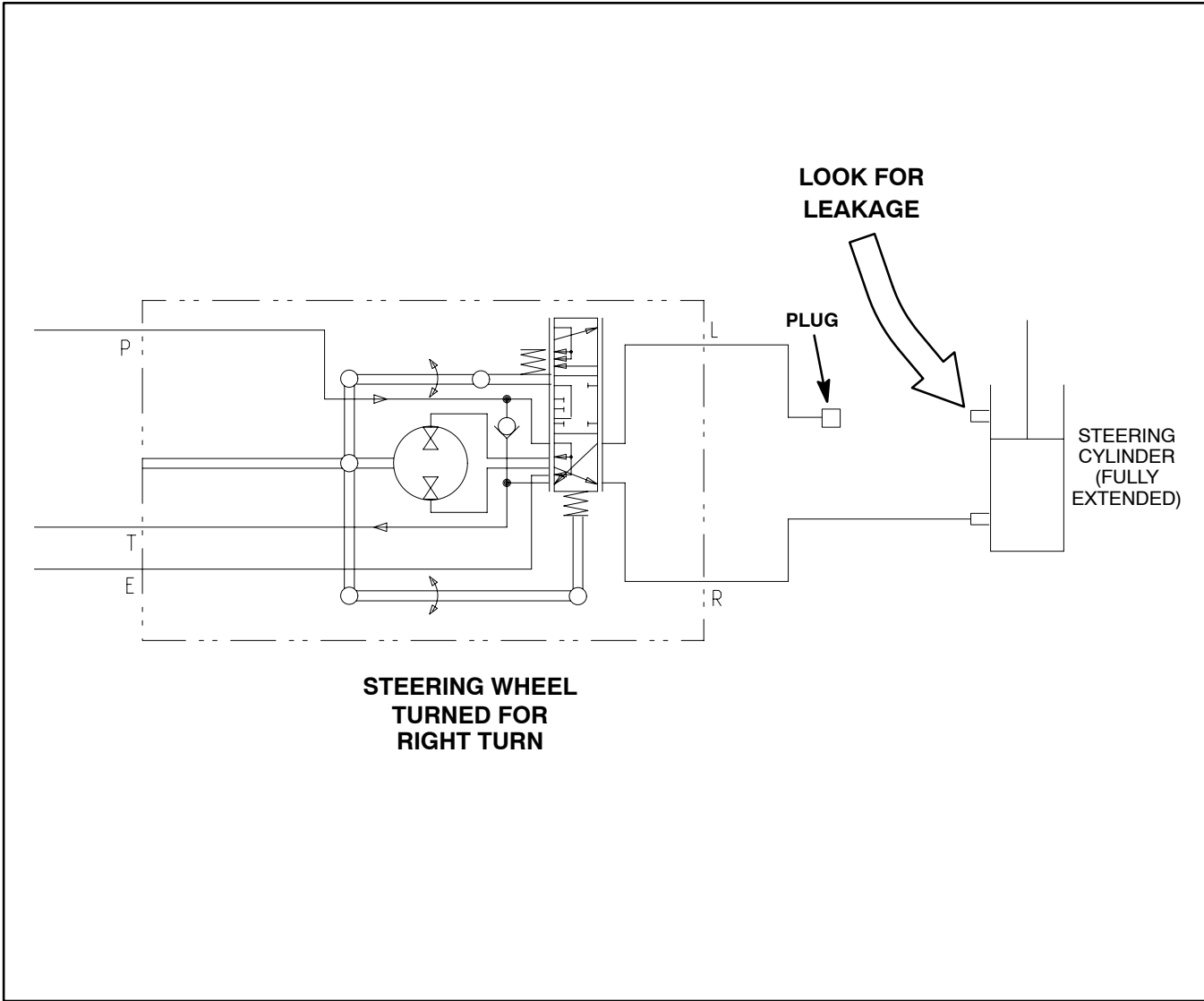

Figure 28

Procedure for Steering Cylinder Internal Leakage Test (Sand Pro 5040 and Infield Pro 5040):

NOTE: Steering on Sand Pro 5040 and Infield Pro 5040 machines will be affected by incorrect front tire pressure, binding in the hydraulic steering cylinder, excessive weight on the vehicle and/or binding of the castor fork assembly. Make sure that these items are checked before proceeding with any hydraulic testing, disassembly or repairs.

1. Make sure hydraulic oil is at normal operating temperature by operating the machine for approximately 10 minutes. Make sure the hydraulic tank is full.
2. Park machine on a level surface with the attachment lowered. Make sure engine is off and the parking brake is engaged.
3. Read Precautions for Hydraulic Testing.
4. Perform the Implement Relief Pressure and Gear Pump (P2) Flow tests to make sure that relief valve and pump are functioning correctly.
5. Determine if the steering cylinder has internal leakage using the following procedure:

A. Turn the steering wheel all the way to the right (clockwise) so the steering cylinder rod is fully extended.

IMPORTANT: Make sure to thoroughly clean around all hydraulic connections that will be disassembled.

B. Remove hydraulic hose from the 90° fitting on the rod end of the steering cylinder (Fig. 29). Plug the end of the hose.

C. With the engine off, continue turning the steering wheel to the right (clockwise) with the steering cylinder fully extended. Observe the open fitting on the steering cylinder as the steering wheel is turned. If oil comes out of the fitting while turning the steering wheel to the right, the steering cylinder has internal leakage and must be repaired or replaced.

D. Remove plug from the hydraulic hose. Reconnect hose to the steering cylinder fitting.

6. If steering problem exists and steering cylinder tested acceptably, steering control valve requires service (see Steering Control Valve and Steering Control Valve Service in the Service and Repairs section).

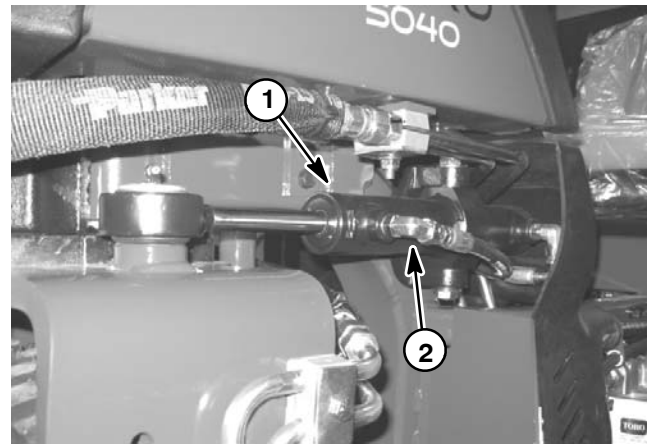

Figure 29

1. Steering cylinder
2. Rod end fitting

Service and Repairs

General Precautions for Removing and Installing Hydraulic System Components

Before Repair or Replacement of Components

1. Before removing any parts from the hydraulic system, park machine on a level surface, apply parking brake, lower attachment and stop engine. Remove key from ignition switch.
2. Thoroughly clean machine before disconnecting, removing or disassembling any hydraulic components. Make sure hydraulic components, hoses, connections and fittings are cleaned thoroughly. Always keep in mind the need for cleanliness when working on hydraulic components.

**WARNING**

Before disconnecting or performing any work on the hydraulic system, all pressure in the system must be relieved. See Relieving Hydraulic System Pressure in the General Information section.

3. Put caps or plugs on any hydraulic lines, hydraulic fittings or components left open or exposed to prevent hydraulic system contamination.
4. Put labels on disconnected hydraulic lines and hoses for proper installation after repairs are completed.
5. Note the position of hydraulic fittings (especially elbow fittings) on hydraulic components before removal. Mark parts if necessary to make sure they will be aligned properly when reinstalling hydraulic fittings, hoses and tubes.

After Repair or Replacement of Components

1. Check oil level in the hydraulic tank and add correct oil if necessary. Drain and refill hydraulic tank and change hydraulic oil filter if component failure was severe or system is contaminated (see Flush Hydraulic System).
2. Lubricate o-rings and seals with clean hydraulic oil before installing hydraulic components.
3. Make sure caps or plugs are removed from the hydraulic tubes, hydraulic fittings and components before reconnecting.
4. Use proper tightening methods when installing hydraulic hoses and fittings (see Hydraulic Fitting Installation in the General Information section).
5. After repairs, check control linkages or cables for proper adjustment, binding or broken parts.
6. After connecting or replacing any hydraulic components, operate machine functions slowly until air is out of system (see Charge Hydraulic System).
7. Check for hydraulic oil leaks. Shut off engine and correct leaks if necessary. Check oil level in hydraulic tank and add correct oil if necessary.

Check Hydraulic Lines and Hoses

**WARNING**

Keep body and hands away from pin hole leaks or nozzles that eject hydraulic fluid under high pressure. Use paper or cardboard, not hands, to search for leaks. Hydraulic fluid escaping under pressure can have sufficient force to penetrate the skin and cause serious injury. If fluid is injected into the skin, it must be surgically removed within a few hours by a doctor familiar with this type of injury. Gangrene may result from such an injury.

Check hydraulic lines and hoses daily for leaks, kinked lines, loose mounting supports, wear, loose fittings, weather deterioration and chemical deterioration. Make any necessary repairs before operating the machine.

Flush Hydraulic System

IMPORTANT: Flush the hydraulic system any time there is a severe component failure or if the system is contaminated (oil appears milky, black or contains metal particles).

IMPORTANT: Flush hydraulic system when changing from petroleum base hydraulic fluid to a biodegradable fluid such as Toro Biodegradable Hydraulic Fluid.

IMPORTANT: If a failure occurs in the traction circuit, traction circuit component disassembly and thorough cleaning may be required to remove contaminants from the traction circuit. Because the traction circuit is a closed loop, any contamination will remain in the circuit and can cause additional component damage unless it is removed.

1. Make sure hydraulic oil is at normal operating temperature by operating the machine for at least four (4) hours.
2. Park machine on a level surface, lower attachment, stop engine, apply parking brake and remove key from ignition switch.

 WARNING
<p>Before disconnecting or performing any work on the hydraulic system, all pressure in the system must be relieved. See Relieving Hydraulic System Pressure in the General Information section.</p>

IMPORTANT: Make sure to thoroughly clean around all hydraulic connections that will be disassembled.

3. Drain hydraulic tank (see Operator’s Manual).
4. Drain hydraulic system. Drain all hoses, tubes and components while the system is warm.
5. Change and replace hydraulic oil filter (see Operator’s Manual).

6. Inspect and clean hydraulic oil tank (see Hydraulic Tank Inspection in this section).

7. Reconnect all hydraulic hoses, lines and components that were disconnected to drain hydraulic system.

NOTE: Use only hydraulic fluids specified in Operator’s Manual. Other fluids may cause system damage.

8. Fill hydraulic tank with **new** hydraulic fluid (see Operator’s Manual).

9. Disconnect and ground engine spark plug wires to prevent the engine from starting. Make sure that traction pedal and lift control lever are in the **neutral** position.

10. Turn ignition key switch to START and engage starter for 10 seconds to prime the hydrostat. Repeat this step again.

11. Connect spark plug wires to spark plugs.

12. Start engine and let it run at low idle (**1750 RPM**) for a minimum of 2 minutes. Increase engine speed to high idle (**3400 RPM**) for a minimum of 1 minute under no load.

13. Raise and lower attachment several times. On Sand Pro 5040 and Infield Pro 5040 machines, turn steering wheel fully left and right several times.

14. Shut off engine and check for hydraulic oil leaks. Check oil level in hydraulic tank and add correct amount of oil if necessary (see Operator’s Manual).

15. Operate the machine for 2 hours under normal operating conditions.

16. Check condition of hydraulic oil. If the new fluid shows any signs of contamination, repeat steps 1 through 14 again until oil is clean. If changing to biodegradable fluid, repeat steps 1 through 14 again at least once and until the oil is clean.

17. Assume normal operation and follow recommended maintenance intervals.

Charge Hydraulic System

NOTE: When initially starting the hydraulic system with new or rebuilt components such as motors, pumps or lift cylinders, it is important that the hydraulic system be charged properly. Air must be purged from the system and its components to reduce the chance of damage.

IMPORTANT: Change hydraulic oil filter whenever hydraulic components are repaired or replaced.

1. Position machine on a level surface with the engine off.
2. Make sure all hydraulic connections, lines and components are secured tightly.
3. If component failure was severe or if the hydraulic system is contaminated, flush and refill hydraulic system and tank (see Flush Hydraulic System).
4. Make sure hydraulic tank is full. Add correct oil if necessary (see Operator's Manual).
5. Check traction rod to the hydrostat for proper adjustment, binding or broken parts.
6. Disconnect and ground engine spark plug wires to prevent the engine from starting.
7. Make sure traction pedal and the lift control lever are in the **neutral** position. Turn ignition key switch to START; engage starter for **ten (10) seconds** to prime the traction and charge pumps. Repeat this step again.
8. Connect spark plug wires to spark plugs.



WARNING

Before jacking up the machine, review and follow Jacking Instructions in Chapter 1 – Safety.

9. Raise front wheel and one rear wheel off the ground and place support blocks under the frame. Chock remaining rear wheel to prevent movement of the machine.



CAUTION

Front wheel and one rear wheel will be off the ground. Make sure machine is supported so it will not move and accidentally fall to prevent injuring anyone under machine.

10. Make sure traction pedal and lift control lever are in **neutral**. Start engine and run at low idle speed (**1750 RPM**). The charge pump should pick up oil and fill the hydraulic system. If there is no indication of fill in 30 seconds, stop the engine and determine the cause.

11. After the hydraulic system starts to show signs of fill, actuate lift control lever until the lift cylinder moves in and out several times. If the cylinder does not move after 10 to 15 seconds or if the pump emits abnormal sounds, shut the engine off immediately and determine cause or problem. Inspect for the following:

- A. Loose filter or suction lines.
- B. Incorrect hydraulic hose routing.
- C. Blocked suction line.
- D. Faulty charge relief valve in hydrostat.
- E. Faulty charge pump (gear pump P1).

12. If lift cylinder moves in 10 to 15 seconds, proceed to step 13.

13. Operate the traction pedal in the forward and reverse directions. The wheels off the ground should rotate in the proper direction.

- A. If the wheels rotate in the wrong direction, stop engine, remove lines from top of hydrostat pump and reverse the connections.
- B. If the wheels rotate in the proper direction, stop engine.

14. Adjust traction pedal to the neutral position (see Operator's Manual).

15. Check and adjust traction neutral switch (see Operators Manual).

16. Lower machine to ground. Remove chock from rear wheel.

17. If the traction pump or a wheel motor was replaced or rebuilt, run the traction unit so all wheels turn slowly for 10 minutes.

18. Operate machine by gradually increasing its work load to full over a 10 minute period.

19. Stop the machine. Check hydraulic oil level and adjust if necessary. Check hydraulic components for leaks. Tighten any loose connections.

This page is intentionally blank.

Hydraulic Tank

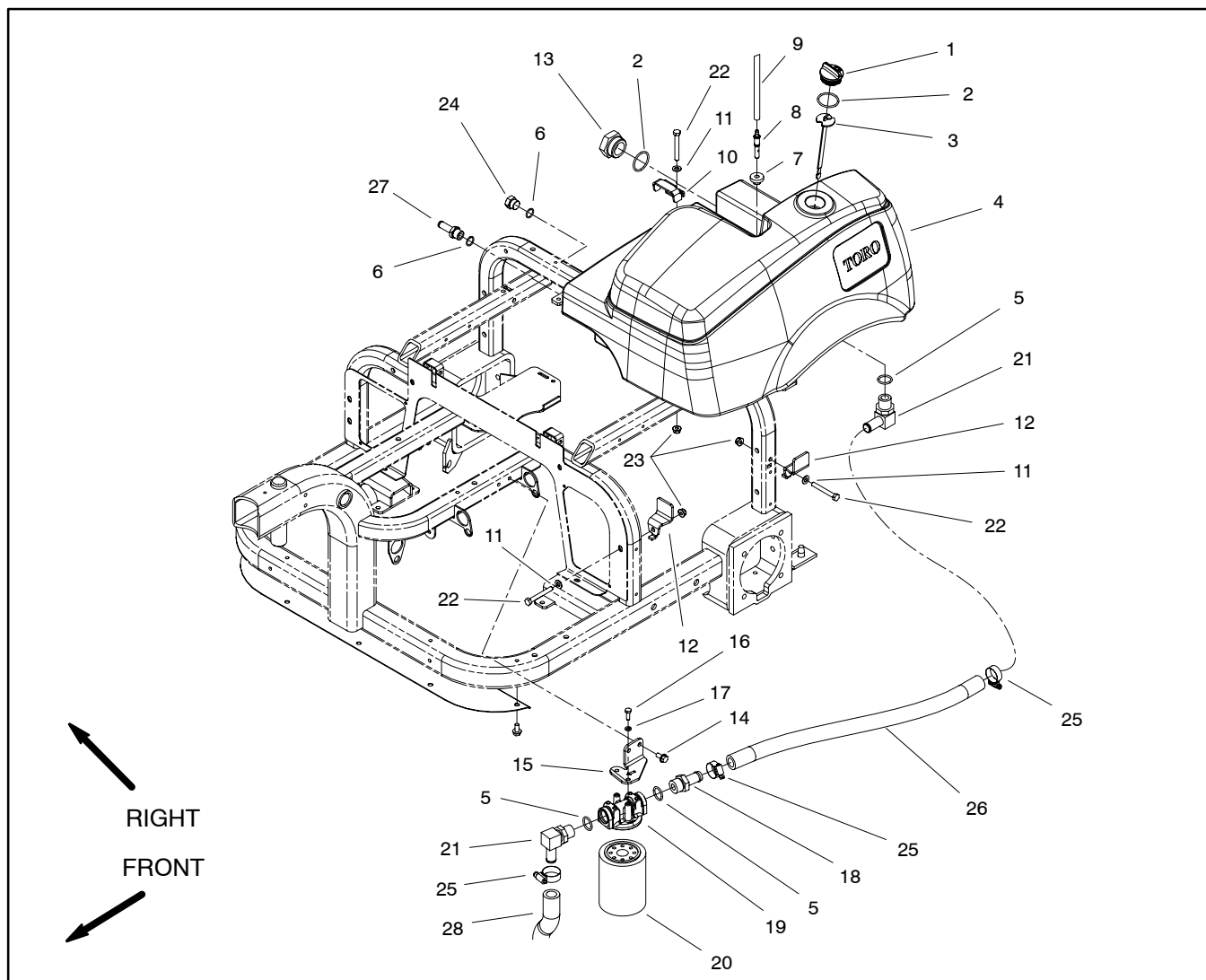

Figure 30

- | | | |
|-------------------|--------------------------------|---------------------------|
| 1. Cap | 11. Flat washer | 20. Oil filter |
| 2. O-ring | 12. Tank clamp | 21. Hydraulic 90° fitting |
| 3. Dipstick | 13. Plug | 22. Cap screw |
| 4. Hydraulic tank | 14. Washer head screw (2 used) | 23. Flange nut |
| 5. O-ring | 15. Filter bracket | 24. Plug |
| 6. O-ring | 16. Cap screw (2 used) | 25. Hose clamp |
| 7. Bushing | 17. Lock washer (2 used) | 26. Suction hose |
| 8. Vent fitting | 18. Hydraulic fitting | 27. Hydraulic fitting |
| 9. Hose | 19. Oil filter head | 28. Suction hose |
| 10. Tank clamp | | |

Removal (Fig. 30)

1. Park machine on a level surface, lower attachment, stop engine, apply parking brake and remove key from ignition switch.

2. Remove two (2) cap screws and flat washers that secure center shroud to machine (Fig. 31). Lift center shroud from frame.

3. Place drain pan under hydraulic oil filter. Make sure that drain pan is large enough to hold hydraulic tank contents (5 gallons/18.9 liters).

4. Remove hydraulic oil filter from filter head to allow hydraulic tank to drain.

5. Remove left rear wheel from machine (see Rear Wheel Removal in the Service and Repairs section of Chapter 6 – Chassis).

6. Read the General Precautions for Removing and Installing Hydraulic System Components at the beginning of the Service and Repairs section of this chapter.

7. Thoroughly clean hydraulic hose ends and fittings on hydraulic tank to prevent hydraulic system contamination.

8. Label all hydraulic connections on hydraulic tank for assembly purposes.

9. Disconnect hydraulic hoses from hydraulic tank. Allow hoses to drain into a suitable container.

10. Put caps or plugs on disconnected hoses and fittings to prevent contamination.

11. Remove three (3) tank clamps (items 10 and 12) that secure hydraulic tank to the frame.

12. Remove hydraulic tank from machine.

13. If hydraulic fittings are to be removed from hydraulic tank, mark fitting orientation to allow correct assembly. Remove fittings from tank.

Installation (Fig. 30)

1. If fittings were removed from hydraulic tank, install fittings with new o-rings to tank using marks made during the removal process to properly orientate fittings.

2. Position hydraulic tank to machine frame.

3. Secure hydraulic tank to frame with three (3) tank clamps (items 10 and 12).

4. Remove caps or plugs from disconnected hydraulic lines and fittings.

5. Connect hydraulic lines to fittings on hydraulic tank. Use labels placed during the removal process to properly install hoses to tank.

6. Install left rear wheel to machine (see Rear Wheel Installation in the Service and Repairs section of Chapter 6 – Chassis).

7. Install new hydraulic oil filter (see Operator's Manual).

8. Position center shroud to frame and secure with two (2) cap screws and flat washers (Fig. 31).

9. Fill hydraulic tank with correct hydraulic oil (see Operator's Manual).

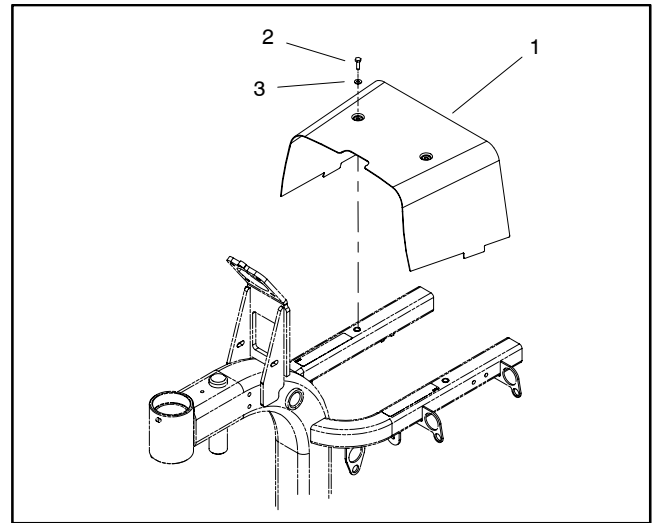

Figure 31

1. Center shroud

2. Cap screw (2 used)

3. Flat washer (2 used)

Oil Cooler

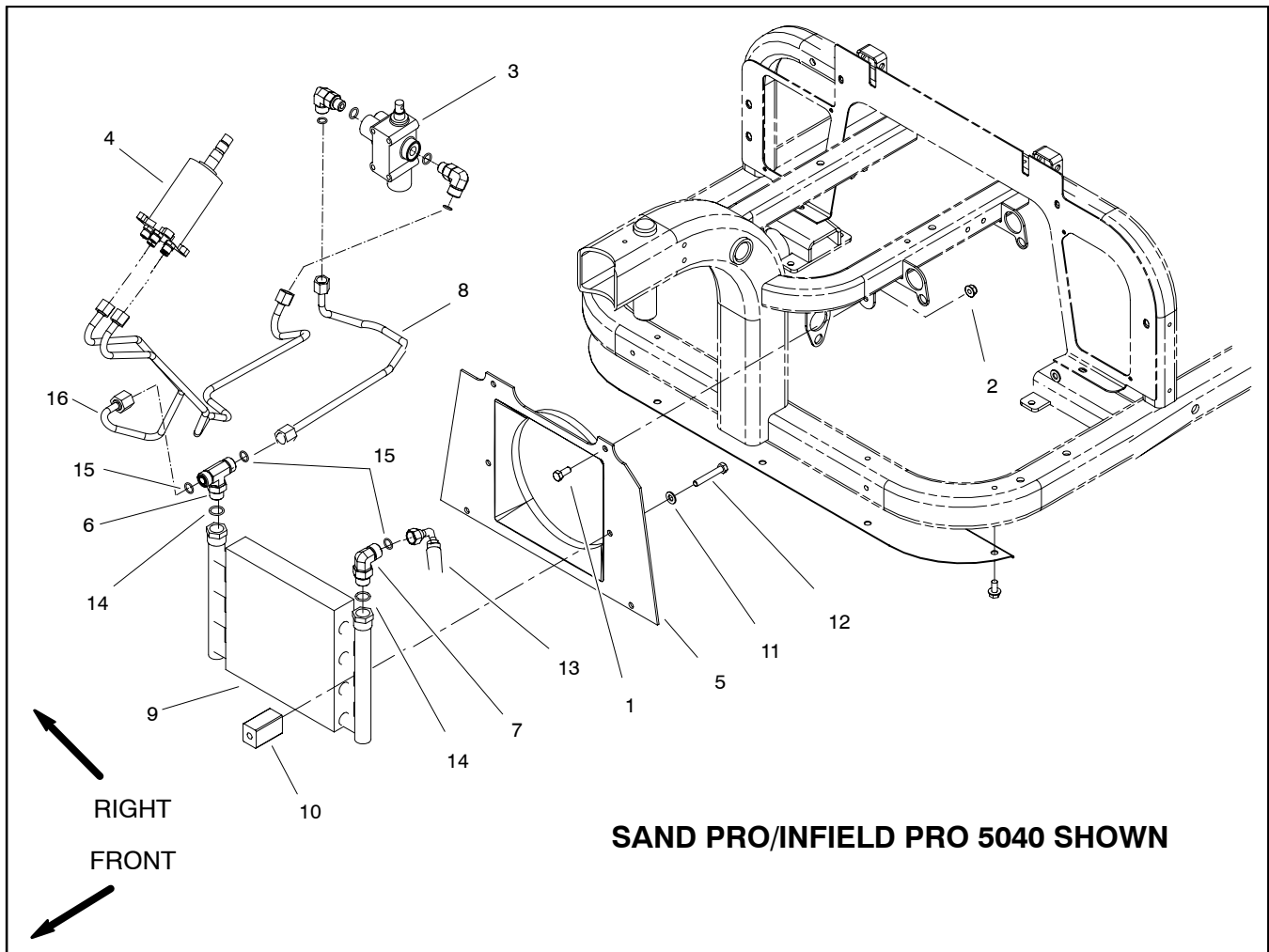

Figure 32

- | | | |
|---------------------------|---------------------------|------------------------|
| 1. Cap screw (4 used) | 7. 90° hydraulic fitting | 12. Cap screw (2 used) |
| 2. Flange nut (4 used) | 8. Hydraulic tube | 13. Hydraulic hose |
| 3. Lift control valve | 9. Oil cooler | 14. O-ring |
| 4. Steering control valve | 10. Rubber clamp (2 used) | 15. O-ring |
| 5. Fan shroud | 11. Flat washer (2 used) | 16. Hydraulic tube |
| 6. Tee fitting | | |

Removal (Figs. 32 and 34)

1. Park machine on a level surface, lower attachment, stop engine, apply parking brake and remove key from ignition switch.
2. Remove two (2) cap screws and flat washers that secure center shroud to machine (Fig. 33). Lift center shroud from frame.
3. Thoroughly clean hydraulic hose ends and fittings on oil cooler to prevent hydraulic system contamination. Label hydraulic connections for assembly purposes.



WARNING

Before disconnecting or performing any work on the hydraulic system, all pressure in the system must be relieved. See Relieving Hydraulic System Pressure in the General Information section.

4. Disconnect hydraulic lines from fittings on oil cooler. Allow hoses to drain into a suitable container.

5. Put caps or plugs on disconnected lines and fittings to prevent contamination.
6. Remove four (4) cap screws and flange nuts that secure fan shroud to frame.
7. Carefully remove oil cooler and fan shroud from machine taking care not to damage fan on hydrostat.
8. Remove two (2) cap screws, flat washers and rubber clamps that secure oil cooler to fan shroud. Separate oil cooler from fan shroud.
9. If hydraulic fittings are to be removed from oil cooler, mark fitting orientation to allow correct assembly. Remove fittings from oil cooler.

Installation (Figs. 32 and 34)

1. If fittings were removed from oil cooler, install fittings with new o-rings to oil cooler using marks made during the removal process to properly orientate fittings.
2. Secure oil cooler to fan shroud with two (2) cap screws, flat washers and rubber clamps.
3. Carefully position oil cooler and fan shroud to frame.
4. Secure fan shroud to frame with four (4) cap screws and flange nuts.
5. Remove caps or plugs from disconnected hydraulic lines and fittings.
6. Position new o-rings and connect hydraulic lines to fittings on oil cooler. Use labels placed during the removal process to properly install hoses to oil cooler.
7. Position center shroud to frame and secure with two (2) cap screws and flat washers (Fig. 33).
8. Check and adjust oil level in hydraulic tank (see Operator's Manual).

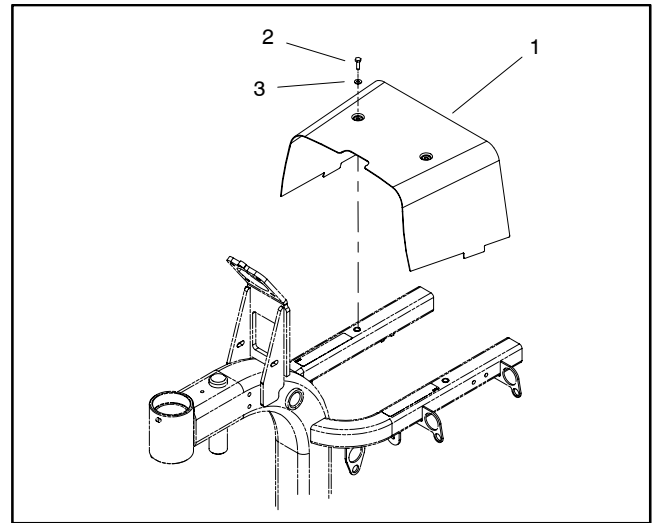

Figure 33

- | | |
|-----------------------|-------------------------|
| 1. Center shroud | 3. Flat washer (2 used) |
| 2. Cap screw (2 used) | |

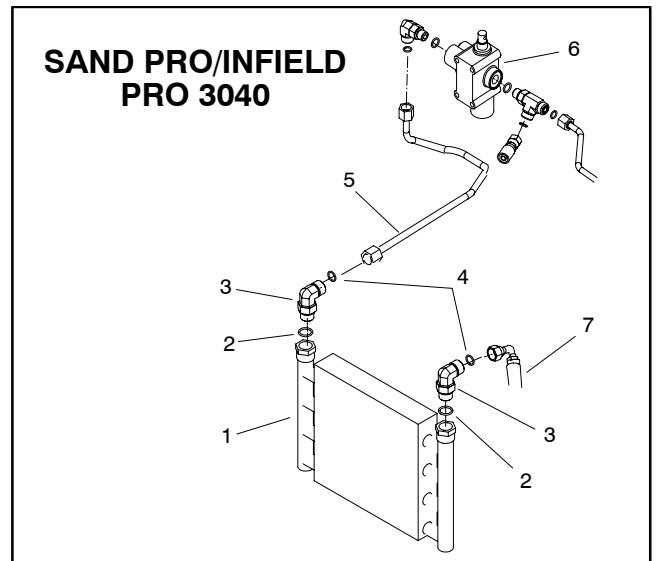

Figure 34

- | | |
|--------------------------|-----------------------|
| 1. Oil cooler | 5. Hydraulic tube |
| 2. O-ring | 6. Lift control valve |
| 3. 90° hydraulic fitting | 7. Hydraulic hose |
| 4. O-ring | |

Front Wheel Motor

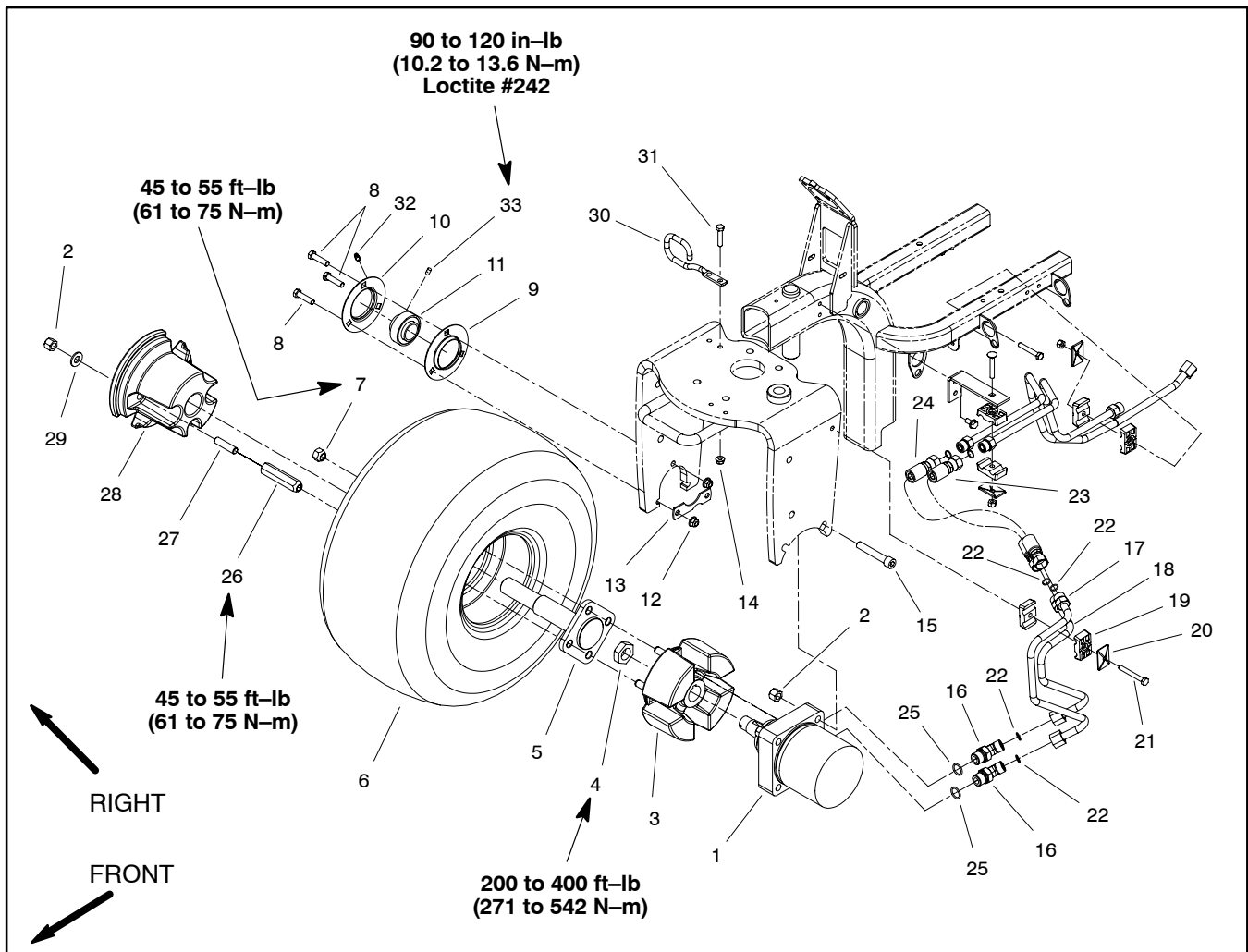

Figure 35

- | | | |
|----------------------|--------------------------------|---------------------------------------|
| 1. Wheel motor | 12. Flange nut (3 used) | 23. Hydraulic hose |
| 2. Lock nut (2 used) | 13. Bearing tab | 24. Hydraulic hose |
| 3. Wheel hub | 14. Flange nut (2 used) | 25. O-ring |
| 4. Lock nut | 15. Socket head screw (2 used) | 26. Wheel weight adapter (SP/IP 3040) |
| 5. Spindle | 16. Hydraulic fitting | 27. Wheel weight stud (SP/IP 3040) |
| 6. Front wheel | 17. Hydraulic tube | 28. Wheel weight (SP/IP 3040) |
| 7. Lug nut | 18. Hydraulic tube | 29. Thrust washer (SP/IP 3040) |
| 8. Cap screw | 19. Tube clamp | 30. Hose guide |
| 9. Flangette | 20. Cover plate | 31. Cap screw (2 used) |
| 10. Flangette | 21. Cap screw | 32. Grease fitting |
| 11. Bearing | 22. O-ring | 33. Set screw |

Removal (Fig. 35)

1. Park machine on a level surface, lower attachment, stop engine, apply parking brake and remove key from ignition switch.
2. Thoroughly clean hydraulic hose ends and fittings on wheel motor to prevent hydraulic system contamination.
3. Label hydraulic connections at front wheel motor for assembly purposes.



WARNING

Before disconnecting or performing any work on the hydraulic system, all pressure in the system must be relieved. See Relieving Hydraulic System Pressure in the General Information section.

4. Disconnect hydraulic lines from fittings on front wheel motor. Allow hoses to drain into a suitable container.
5. Put caps or plugs on disconnected lines and fittings to prevent contamination.
6. Remove front wheel from machine (see Front Wheel Removal in the Service and Repairs section of Chapter 6 – Chassis). Separate wheel motor and wheel hub from front wheel and spindle.
7. Secure wheel hub in a vise. Loosen but do not remove lock nut that secures wheel hub to wheel motor.

IMPORTANT: DO NOT hit wheel hub, wheel hub puller or wheel motor with a hammer during wheel hub removal or installation. Hammering may cause damage to the wheel motor.

8. Using hub puller (see Special Tools), loosen wheel hub from wheel motor.
9. Remove wheel hub and motor from vise. Remove lock nut and hub from motor shaft. Locate and retrieve woodruff key.
10. If hydraulic fittings are to be removed from motor, mark fitting orientation to allow correct assembly. Remove fittings from motor.

Installation (Fig. 35)

1. If fittings were removed from wheel motor, install fittings with new o-rings to motor using marks made during the removal process to properly orientate fittings.
2. Thoroughly clean wheel motor shaft and wheel hub taper.
3. Lock wheel hub in a vise. Install woodruff key into the wheel motor shaft. Slide motor shaft into hub and secure with lock nut. Torque lock nut from 200 to 400 ft-lb (271 to 542 N-m). Remove wheel motor and hub from vise.
4. Install wheel motor, spindle and front wheel to machine (see Front Wheel Installation in the Service and Repairs section of Chapter 6 – Chassis).
5. Remove caps or plugs from disconnected hydraulic lines and fittings.
6. Position new o-rings and connect hydraulic lines to fittings on front wheel motor. Use labels placed during the removal process to properly install hoses to wheel motor.
7. Check and adjust oil level in hydraulic tank (see Operator's Manual).
8. Operate machine functions slowly until air is out of system (see Charge Hydraulic System in this section).

Rear Wheel Motor

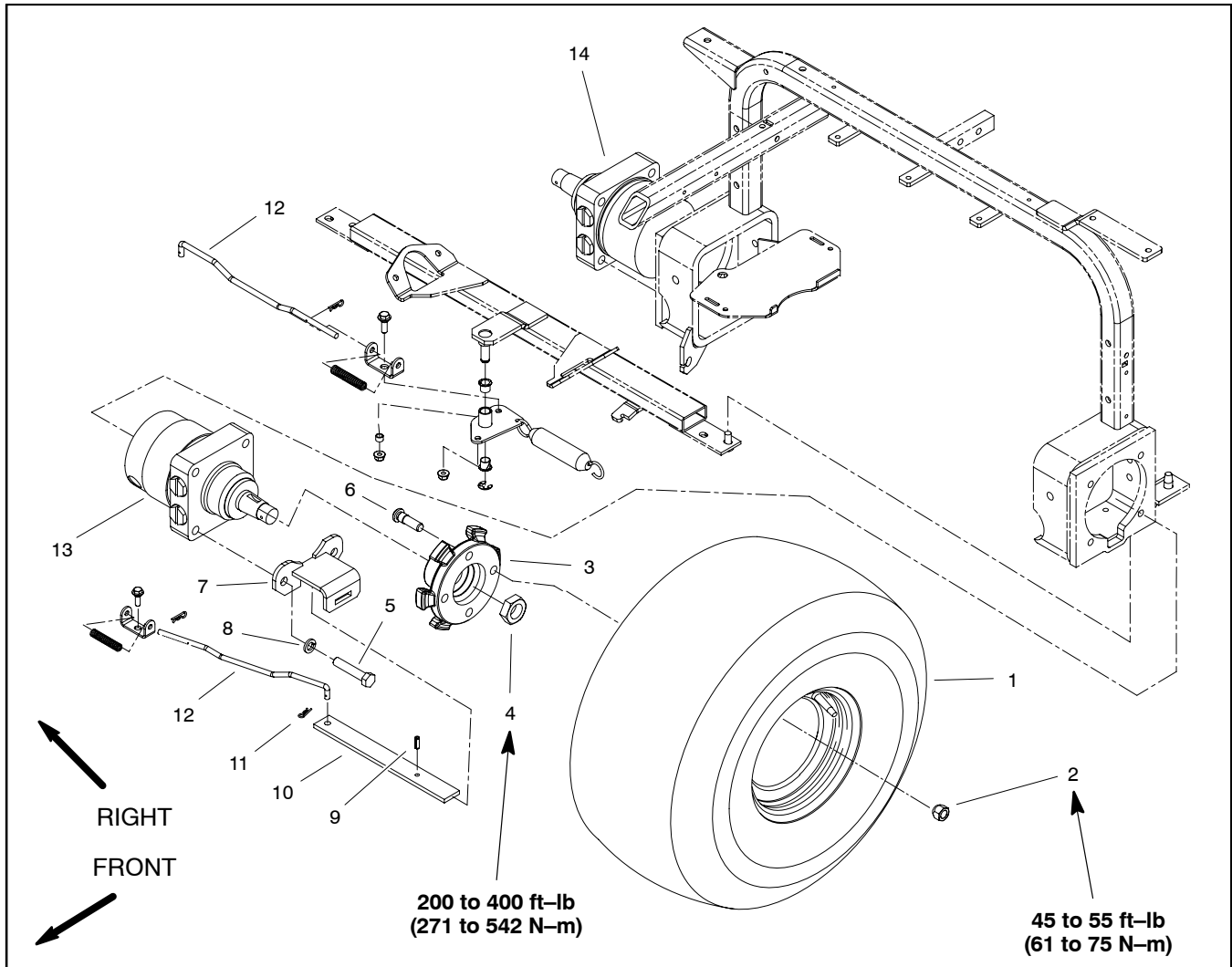



Figure 36

- | | | |
|---------------------------------|-----------------------------------|--------------------|
| 1. Rear wheel assembly | 6. Drive stud (4 used per wheel) | 11. Hair pin |
| 2. Lug nut (4 used per wheel) | 7. Brake bracket | 12. Brake rod |
| 3. Wheel hub | 8. Lock washer (4 used per motor) | 13. LH wheel motor |
| 4. Lock nut | 9. Roll pin | 14. RH wheel motor |
| 5. Cap screw (4 used per motor) | 10. Brake bar | |

Removal (Fig. 36)

1. Park machine on a level surface, lower attachment, stop engine, apply parking brake and remove key from ignition switch.
2. Remove rear wheel from machine (see Rear Wheel Removal in the Service and Repairs section of Chapter 6 – Chassis).
3. Thoroughly clean hydraulic hose ends and fittings on wheel motor to prevent hydraulic system contamination.
4. Label hydraulic connections at wheel motor for assembly purposes.



WARNING

Before disconnecting or performing any work on the hydraulic system, all pressure in the system must be relieved. See Relieving Hydraulic System Pressure in the General Information section.

5. Disconnect hydraulic lines from fittings on rear wheel motor. Allow lines to drain into a suitable container.
6. Put caps or plugs on disconnected lines and fittings to prevent contamination.

7. Loosen but do not remove lock nut that secures wheel hub to wheel motor.

IMPORTANT: DO NOT hit wheel hub, wheel hub puller or wheel motor with a hammer during wheel hub removal or installation. Hammering may cause damage to the wheel motor.

8. Using hub puller (see Special Tools), loosen wheel hub from wheel motor.

9. Remove lock nut and wheel hub from motor shaft. Locate and retrieve woodruff key.

10. Support wheel motor to prevent it from falling. Remove four (4) cap screws and lock washers that secure motor to frame. Slide brake bracket from brake bar.

11. Remove wheel motor from machine.

12. If hydraulic fittings are to be removed from wheel motor, mark fitting orientation to allow correct assembly. Remove fittings from motor.

Installation (Fig. 36)

1. If fittings were removed from wheel motor, install fittings with new o-rings to motor using marks made during the removal process to properly orientate fittings.

2. Position wheel motor to frame. Slide brake bracket onto brake bar.

3. Secure motor and brake bracket to frame with four (4) cap screws and lock washers.

4. Thoroughly clean wheel motor shaft and wheel hub taper.

5. Install woodruff key into the wheel motor shaft. Align wheel hub with woodruff key and brake bar. Slide wheel hub onto motor shaft. Secure hub with lock nut. Torque lock nut from 200 to 400 ft-lb (271 to 542 N-m).

6. Remove caps or plugs from disconnected hydraulic lines and fittings.

7. Position new o-rings and connect hydraulic lines to fittings on rear wheel motor (Fig. 37 and 38). Use labels placed during the removal process to properly install hydraulic lines to wheel motor.

8. Install rear wheel to machine (see Rear Wheel Installation in the Service and Repairs section of Chapter 6 – Chassis).

9. Check and adjust oil level in hydraulic tank (see Operator's Manual).

10. Operate machine functions slowly until air is out of system (see Charge Hydraulic System in this section).

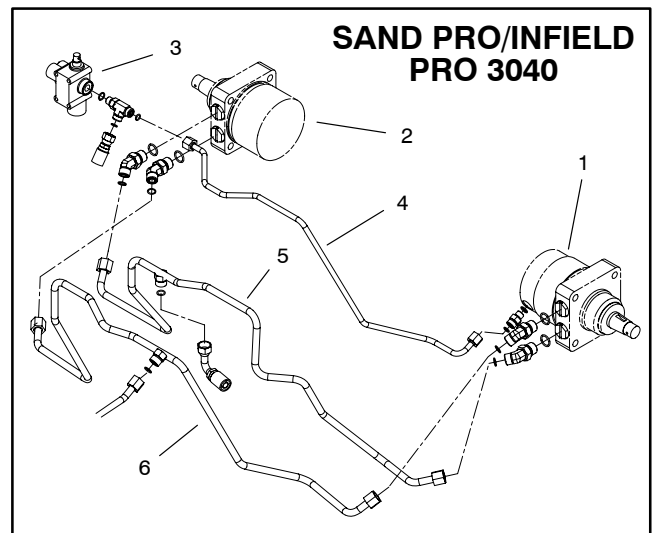

Figure 37

- | | |
|-----------------------|-------------------------|
| 1. LH rear motor | 4. Hydraulic bleed tube |
| 2. RH rear motor | 5. Hydraulic tube |
| 3. Lift control valve | 6. Hydraulic tube |

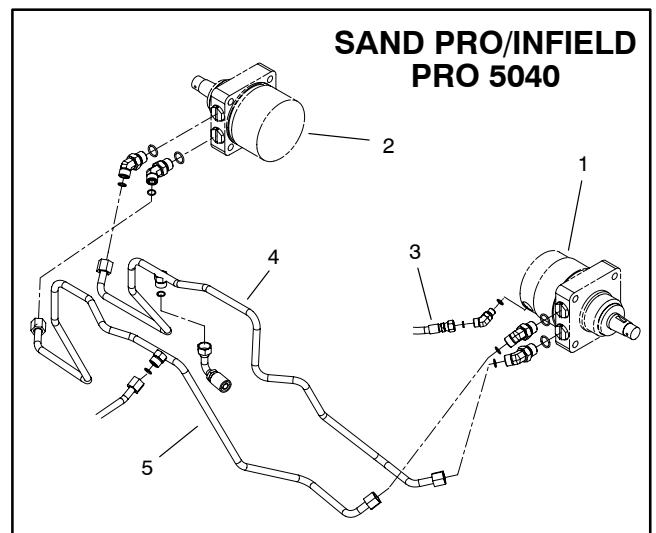

Figure 38

- | | |
|-------------------------|-------------------|
| 1. LH rear motor | 4. Hydraulic tube |
| 2. RH rear motor | 5. Hydraulic tube |
| 3. Hydraulic bleed hose | |

Hydraulic System

Wheel Motor Service

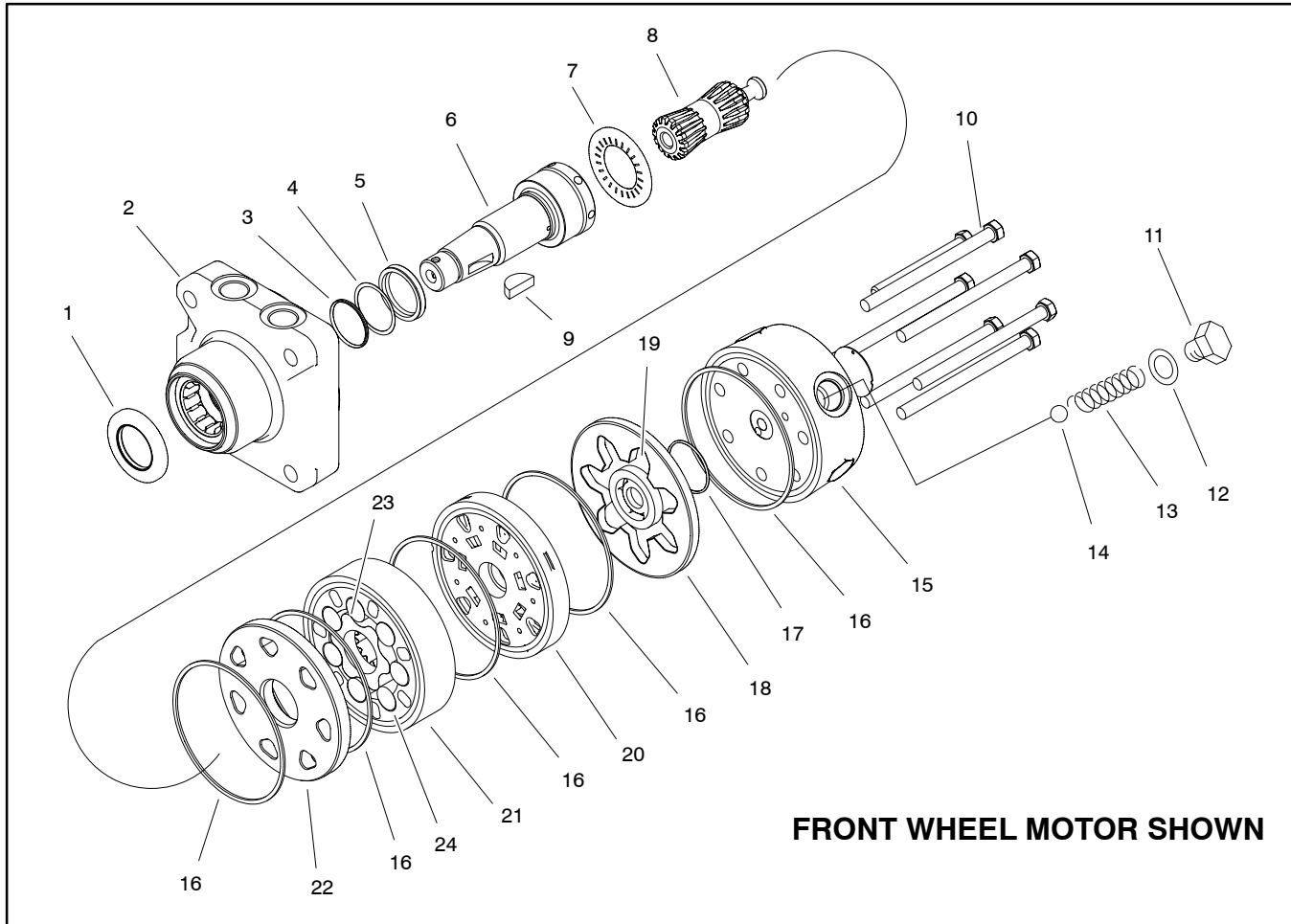

Figure 39

- | | | |
|---------------------|------------------------|---------------------|
| 1. Dirt seal | 9. Woodruff key | 17. Commutator seal |
| 2. Housing assembly | 10. Cap screw (7 used) | 18. Commutator ring |
| 3. Back-up washer | 11. Plug | 19. Commutator |
| 4. Seal ring | 12. O-ring | 20. Manifold |
| 5. Shaft seal | 13. Spring | 21. Stator |
| 6. Coupling shaft | 14. Ball | 22. Wear plate |
| 7. Thrust bearing | 15. End cover | 23. Rotor |
| 8. Drive link | 16. Body seal (5 used) | 24. Vane |

NOTE: The wheel motors used on Sand Pro and Infield Pro machines have the same basic construction. The motors do however have internal differences.

The front wheel motor (shown in Fig. 39) has a different displacement (17.1 in³ (280 cm³) per revolution) than the rear motors and has a clockwise direction for the forward direction. The front motor is also equipped with a check valve that allows the motor to over run during tight turns in the forward direction and by-passes flow in reverse.

The right and left rear wheel motors have the same displacement (8.6 in³ (141 cm³) per revolution) but have different rotation for the forward direction: the right rear has a clockwise drive direction for forward and the left rear has a counter-clockwise direction. Additionally, the left rear motor has a hot oil shuttle to bleed off a small amount of hydraulic fluid for cooling of the closed loop traction circuit.

NOTE: For repair of the wheel motors, see the Parker Torqmotor™ Service Procedure (TC, TB, TE, TJ, TF, TG, TH and TL Series) at the end of this chapter.

This page is intentionally blank.

Lift Control Valve

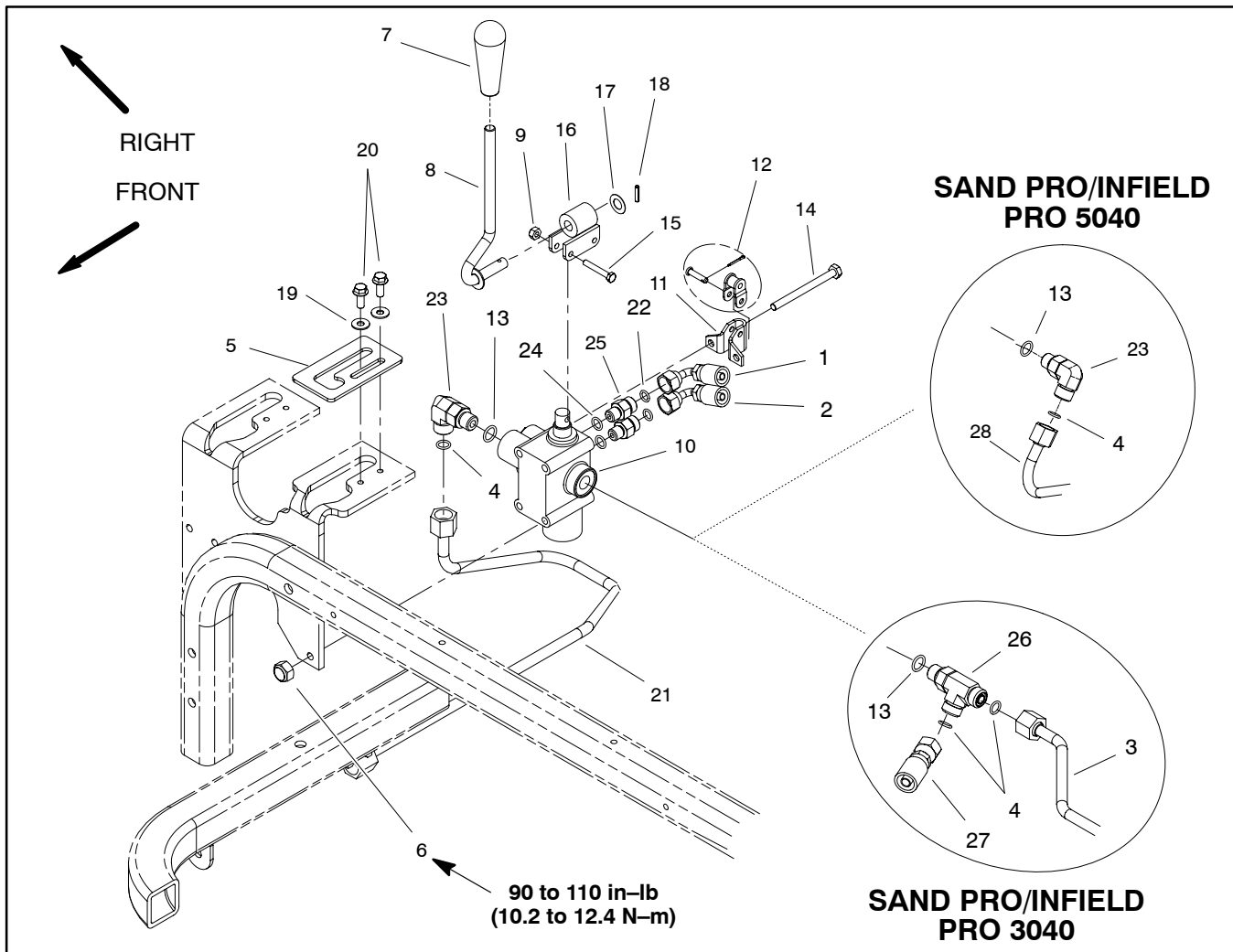

Figure 40

- | | | |
|------------------------|--------------------------|--------------------------------|
| 1. Hydraulic hose | 11. Pivot bracket | 20. Flange head screw (2 used) |
| 2. Hydraulic hose | 12. Offset link assembly | 21. Hydraulic tube |
| 3. Hydraulic tube | 13. O-ring | 22. O-ring |
| 4. O-ring | 14. Cap screw (3 used) | 23. Hydraulic 90° fitting |
| 5. Guide plate | 15. Cap screw (2 used) | 24. O-ring (2 used) |
| 6. Lock nut (3 used) | 16. Pivot | 25. Hydraulic fitting (2 used) |
| 7. Knob | 17. Curved washer | 26. Hydraulic tee fitting |
| 8. Lever | 18. Roll pin | 27. Hydraulic hose |
| 9. Lock nut (2 used) | 19. Flat washer (2 used) | 28. Hydraulic tube |
| 10. Lift control valve | | |

Removal (Fig. 40)

1. Park machine on a level surface, lower attachment, stop engine, apply parking brake and remove key from ignition switch.
2. Remove console from machine to allow access to lift control valve (see Console Removal in the Service and Repairs section of Chapter 6 – Chassis).

3. Read the General Precautions for Removing and Installing Hydraulic System Components at the beginning of the Service and Repairs section of this chapter.
4. Thoroughly clean hydraulic hose ends and fittings on lift control valve to prevent hydraulic system contamination.

5. Label all hydraulic connections for assembly purposes.



WARNING

Before disconnecting or performing any work on the hydraulic system, all pressure in the system must be relieved. See Relieving Hydraulic System Pressure in the General Information section.

6. Disconnect hydraulic lines from fittings on lift control valve. Allow hoses to drain into a suitable container.

7. Put caps or plugs on disconnected lines and fittings to prevent contamination.

8. Remove cap screw and lock nut that secure lift lever pivot to lift control valve spool (Fig. 41).

9. Remove lift control valve from machine:

A. Remove two (2) cap screws and lock nuts that secure lift control valve and pivot bracket to machine. Position lever assembly away from control valve.

B. Remove cap screw and lock nut that secures lift control valve to frame.

C. Remove lift control valve from machine.

10. If hydraulic fittings are to be removed from control valve, mark fitting location and orientation to allow correct assembly. Remove fittings from control valve.

Installation (Fig. 40)

IMPORTANT: Upper hydraulic fitting on rear of lift control valve is an orificed fitting. Make sure that fittings are properly installed in control valve if removed.

1. If fittings were removed from lift control valve, install fittings with new o-rings to lift control valve using marks made during the removal process to properly locate and orientate fittings.

IMPORTANT: If fasteners are over-tightened, lift control valve may bind. Make sure to properly torque fasteners during assembly.

2. Position lift control valve to frame and lift lever assembly to control valve. Secure control valve to machine with removed fasteners. Torque lock nuts (item 6) from 90 to 110 in-lbs (10.2 to 12.4 N-m).

3. Secure lift lever pivot to lift control valve spool with cap screw and lock nut (Fig. 41).

4. Remove caps or plugs from disconnected hydraulic lines and fittings.

5. Position new o-rings and connect hydraulic lines to fittings on lift control valve. Use labels placed during the removal process to properly install hoses to lift control valve.

6. Install console to machine (see Console Installation in the Service and Repairs section of Chapter 6 – Chassis).

7. Check and adjust oil level in hydraulic tank (see Operator's Manual).

8. Operate machine functions slowly until air is out of system (see Charge Hydraulic System in this section).

9. Check float position of lift lever and adjust if necessary (see Operator's Manual).

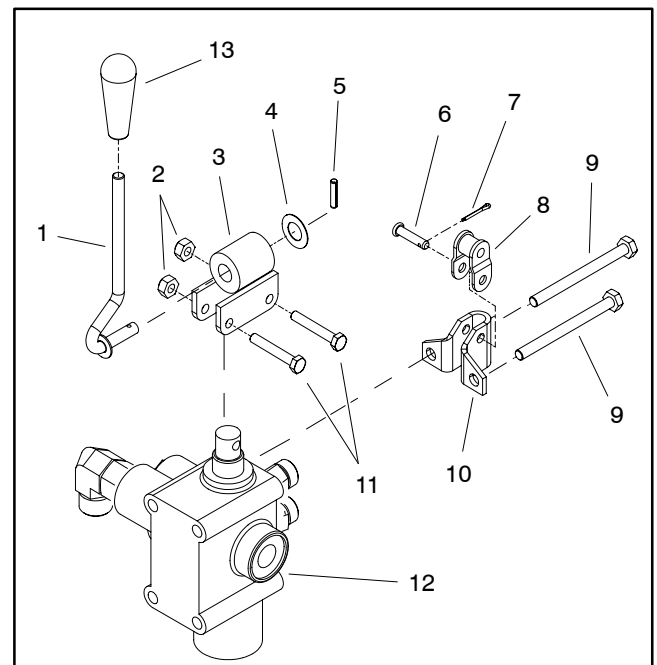

Figure 41

- | | |
|------------------|------------------------|
| 1. Lift lever | 8. Offset link |
| 2. Lock nut | 9. Cap screw |
| 3. Pivot | 10. Pivot bracket |
| 4. Curved washer | 11. Cap screw |
| 5. Roll pin | 12. Lift control valve |
| 6. Clevis pin | 13. Knob |
| 7. Cotter pin | |

Lift Control Valve Service

Disassembly (Fig. 42)

1. Wash lift valve in solvent and dry thoroughly.
2. Carefully mount lift valve in a vise so that mounting pads are against jaws of vise. Lift valve spool retaining ring (item 14) should be facing up.
3. Remove two (2) hex cap plugs (item 1) from side of valve body. Inside valve body, behind each hex cap plug, there is a spring (item 3), check ball (item 4) and cam pin (item 6); remove these parts.

NOTE: Remove check ball seats (item 5) only if they need replacement; the seats are press fit into the valve body.

4. Remove retaining ring (item 14) from spool (item 8). Remove spool retaining ring (item 13), spring retainer (item 10), spacer (item 12), spring (item 11) and second spring retainer (item 10). Carefully push and twist spool to remove spool from valve body.

5. Use a hooked scribe or thin screwdriver to remove o-rings (item 9) from inside bore of valve body (be careful not to scratch valve bore finish). These o-rings are the seals for the spool.

6. Inspect all components for wear, paying special attention to the spool. Signs of wear on one side of the spool may indicate a bent spool. Inspect the spool for flatness and replace if necessary.

Assembly (Fig. 42)

1. Clean all components thoroughly before assembly. Use new o-rings when assembling.
2. Coat all o-rings and spool with clean hydraulic oil before installation into valve body. Assemble components in reverse order of disassembly. Install spool into valve body before inserting cam pins, check balls, springs and hex cap plugs.

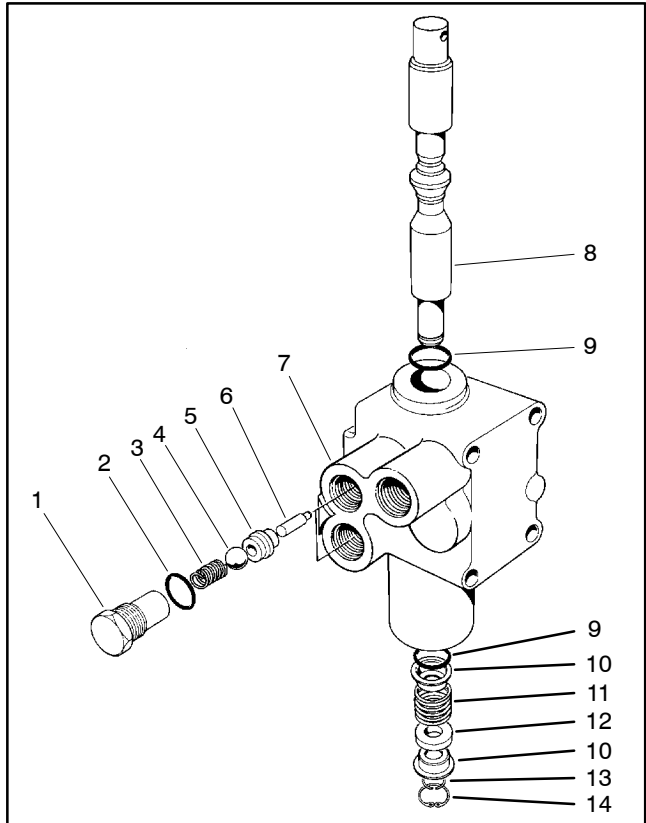

Figure 42

- | | |
|-----------------------------|--------------------------|
| 1. Hex cap plug (2 used) | 8. Spool |
| 2. O-ring (2 used) | 9. O-ring |
| 3. Spring (2 used) | 10. Spring retainer |
| 4. Check ball (2 used) | 11. Spring |
| 5. Check ball seat (2 used) | 12. Spacer |
| 6. Cam pin (2 used) | 13. Spool retaining ring |
| 7. Valve body | 14. Retaining ring |

This page is intentionally blank.

Pump Control Assembly

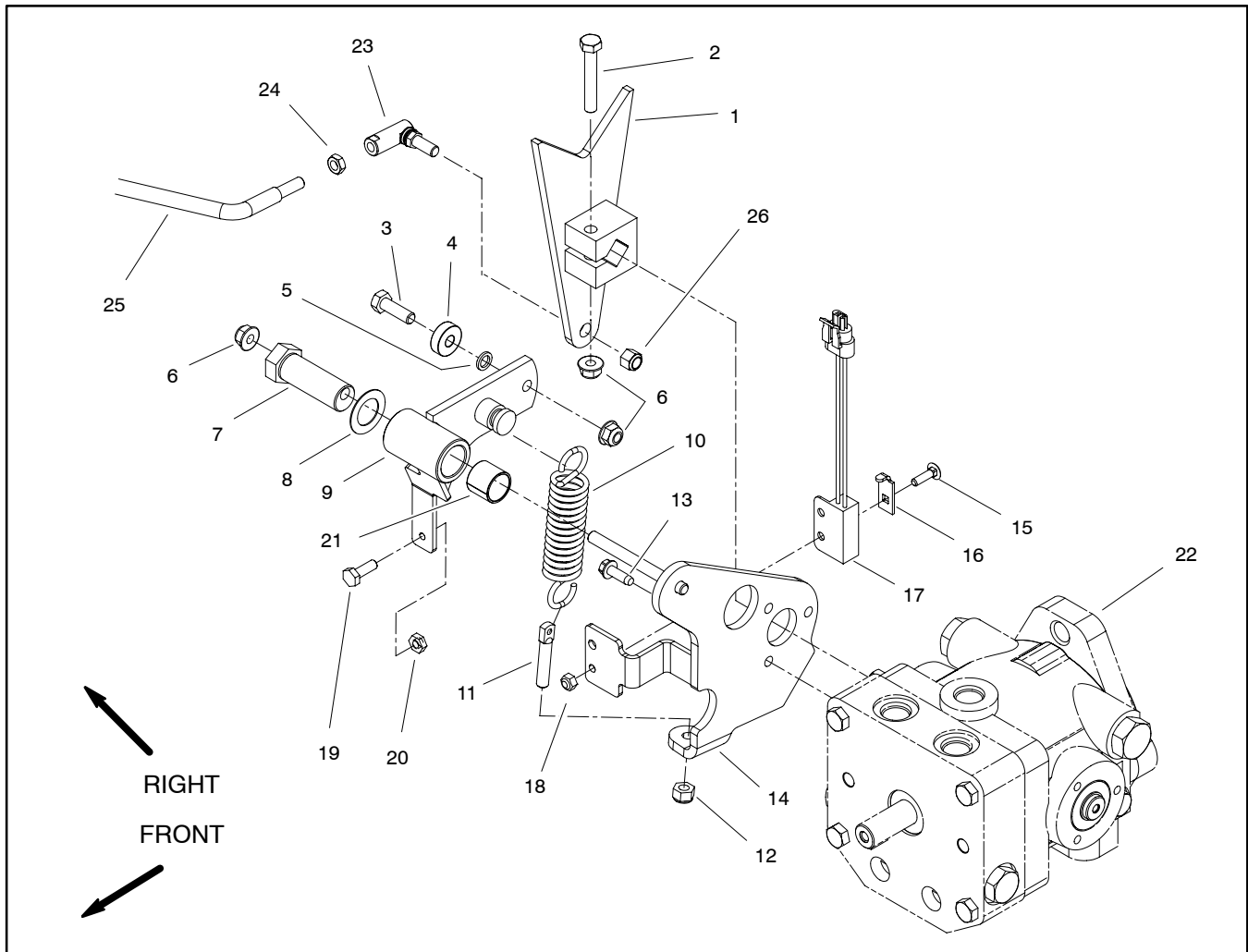

Figure 43

- | | | |
|-------------------|--------------------------------|----------------------|
| 1. Pump lever | 10. Extension spring | 19. Cap screw |
| 2. Cap screw | 11. Adjustment pin | 20. Hex nut |
| 3. Cap screw | 12. Lock nut | 21. Bushing (2 used) |
| 4. Ball bearing | 13. Washer head screw (3 used) | 22. Hydrostat |
| 5. Bearing spacer | 14. Pump plate | 23. Ball joint |
| 6. Flange nut | 15. Carriage screw | 24. Jam nut |
| 7. Traction stud | 16. Switch plate | 25. Traction rod |
| 8. Thrust washer | 17. Neutral switch | 26. Lock nut |
| 9. Neutral arm | 18. Lock nut | |

Disassembly (Fig. 43)

1. Park machine on a level surface, lower attachment, stop engine, apply parking brake and remove key from ignition switch.

2. Remove two (2) cap screws and flat washers that secure center shroud to machine (Fig. 46). Lift center shroud from frame.

3. Remove cap screw, lock nut and flat washer that secures traction rod to pump lever.



CAUTION

The extension spring is under tension and may cause personal injury during removal. Use caution when removing spring from the pump arm.

4. Loosen lock nut on the bottom of the adjustment pin to allow the extension spring to relax. Unhook spring from anchor point of arm.

5. Disassemble remaining pump control components as needed using Figure 43 as a guide.

Assembly (Fig. 43)

1. Assemble pump control components as needed using Figure 43 as a guide.



CAUTION

The extension spring is under tension and may cause personal injury during installation. Use caution when installing spring to the pump arm.

2. Attach extension spring to anchor point of arm. Tighten lock nut on adjustment pin to allow from .475" to .725" (12.1 to 18.4 mm) thread length to extend beyond the lock nut (Fig. 44).

3. If ball joint was removed from traction rod, install ball joint so that distance from center of ball joint stud to center of bearing is from 14.050" to 14.170" (35.7 to 36.0 cm) (Fig. 45).

4. Secure traction rod to pump lever with cap screw, flat washer and lock nut.

5. Make sure that traction neutral switch connector is plugged into machine wire harness.

6. Check and adjust neutral position (see Operator's Manual).

7. Check and adjust traction neutral switch (see Operators Manual).

8. Check traction rod adjustment as follows:



WARNING

Before raising the machine, review and follow Jacking Instructions in Chapter 1 – Safety.

A. Raise machine so front wheel and one rear wheel are off the ground and can rotate freely. Support machine with jackstands or wooden blocking. Chock the rear wheel on the ground to prevent it from rotating.



CAUTION

Use extreme caution because the rear wheel on the ground will be trying to move the machine rearward.

B. Start engine and depress traction pedal fully in the reverse direction. Using a phototac, check that rear wheel speed is from 135 to 180 RPM.

C. If necessary, adjust ball joint on traction rod to provide rear wheel speed from 135 to 180 RPM.

D. With engine stopped, depress traction pedal fully in the forward direction and check that pump lever is rotated fully. Also check that clearance between pedal hub and pedal stop is from 0 to .120" (3 mm). Adjust stop if necessary (see Operator's Manual).

9. Position center shroud to machine and secure with two (2) cap screws and flat washers (Fig. 46).

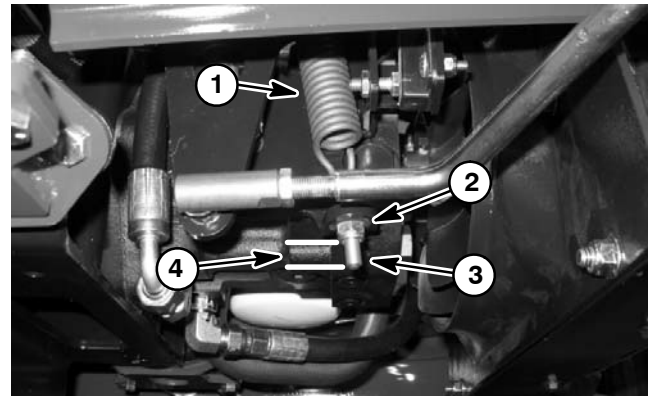

Figure 44

- | | |
|---------------------|---------------------|
| 1. Extension spring | 3. Adjustment pin |
| 2. Lock nut | 4. Thread extension |

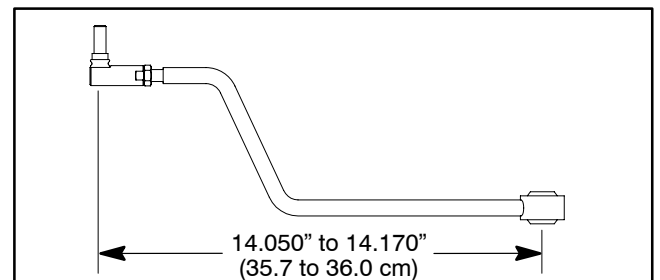

Figure 45

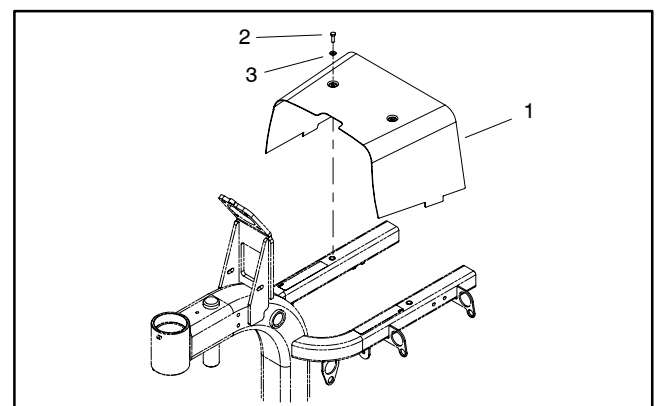

Figure 46

- | | |
|-----------------------|-------------------------|
| 1. Center shroud | 3. Flat washer (2 used) |
| 2. Cap screw (2 used) | |

Hydrostat

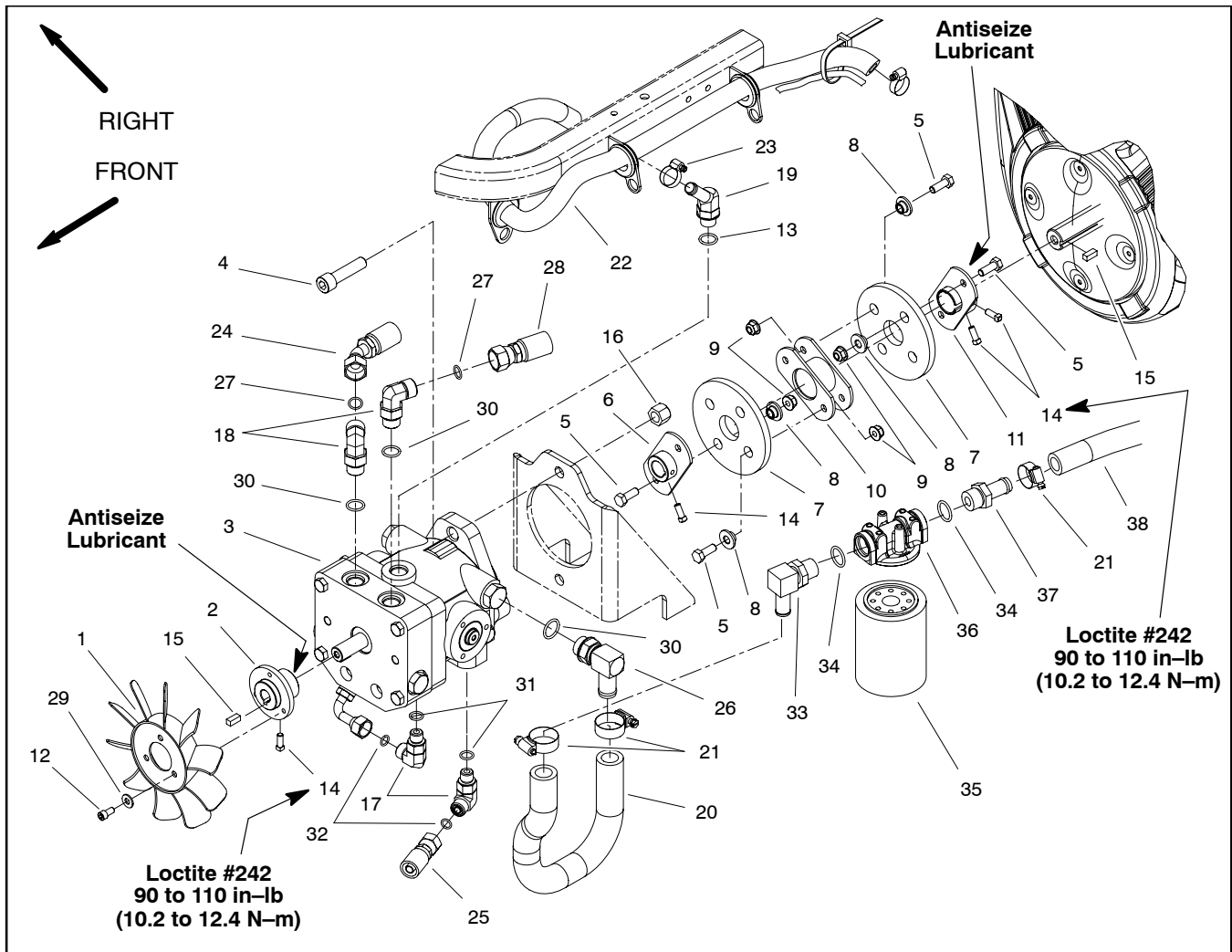

Figure 47

- | | | |
|--------------------------------|---------------------------|--------------------------|
| 1. Cooling fan | 14. Set screw (6 used) | 27. O-ring |
| 2. Fan hub | 15. Square key | 28. Hydraulic hose |
| 3. Hydrostat | 16. Lock nut (2 used) | 29. Flat washer |
| 4. Socket head screw (2 used) | 17. 90° hydraulic fitting | 30. O-ring |
| 5. Cap screw (8 used) | 18. 90° hydraulic fitting | 31. O-ring |
| 6. Pump hub | 19. Hydraulic fitting | 32. O-ring |
| 7. Drive coupler | 20. Suction hose | 33. Hydraulic fitting |
| 8. Coupling spacer (8 used) | 21. Hose clamp | 34. O-ring |
| 9. Lock nut (8 used) | 22. Return hose | 35. Hydraulic oil filter |
| 10. Coupling | 23. Hose clamp | 36. Filter head |
| 11. Engine hub | 24. Hydraulic hose | 37. Hydraulic fitting |
| 12. Socket head screw (3 used) | 25. Hydraulic hose | 38. Suction hose |
| 13. O-ring | 26. Hydraulic fitting | |

NOTE: Fittings and hose connections on the bottom of the hydrostat for Sand Pro 5040 and Infield Pro 5040 machines are shown in Figure 49.

Removal (Fig. 47)

1. Park machine on a level surface, lower attachment, stop engine, apply parking brake and remove key from ignition switch.

2. Read the General Precautions for Removing and Installing Hydraulic System Components at the beginning of the Service and Repairs section of this chapter.

3. Remove two (2) cap screws and flat washers that secure center shroud to machine (Fig. 48). Lift center shroud from frame.

4. Place drain pan under hydraulic oil filter. Make sure that drain pan is large enough to hold hydraulic tank contents (5 gallons/13.2 liters).

5. Remove hydraulic oil filter from filter head to allow hydraulic tank to drain.

6. Remove cap screw, lock nut and flat washer that secures traction rod to pump lever.

7. Disconnect traction neutral switch connector from machine wire harness.

8. Remove oil cooler from machine (see Oil Cooler Removal in this section).

9. Label all hydraulic connections at hydrostat for assembly purposes. Thoroughly clean hydraulic hose and tube ends prior to disconnecting the hoses and tubes.

**CAUTION**

Operate all hydraulic controls to relieve system pressure and avoid injury from pressurized hydraulic oil.

10. Disconnect hydraulic lines from fittings on hydrostat. Allow hoses to drain into a suitable container.

11. Put caps or plugs on disconnected lines and fittings to prevent contamination.

12. Loosen two (2) set screws on the pump hub to allow hub removal from the hydrostat shaft.

13. Support hydrostat to prevent it from falling during removal.

14. Remove two (2) socket head screws and lock nuts that secure hydrostat to engine support.

IMPORTANT: Make sure not to damage the hydrostat, hydrostat coupling, fuel and hydraulic lines, electrical harness or other parts while removing the hydrostat from the machine.

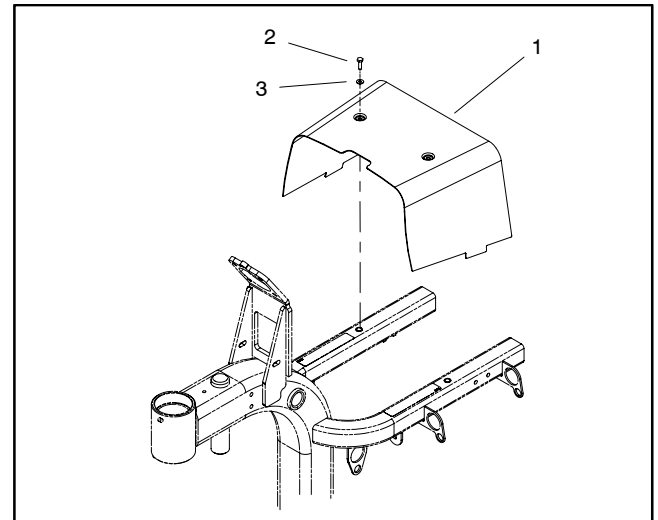

Figure 48

- | | |
|-----------------------|-------------------------|
| 1. Center shroud | 3. Flat washer (2 used) |
| 2. Cap screw (2 used) | |

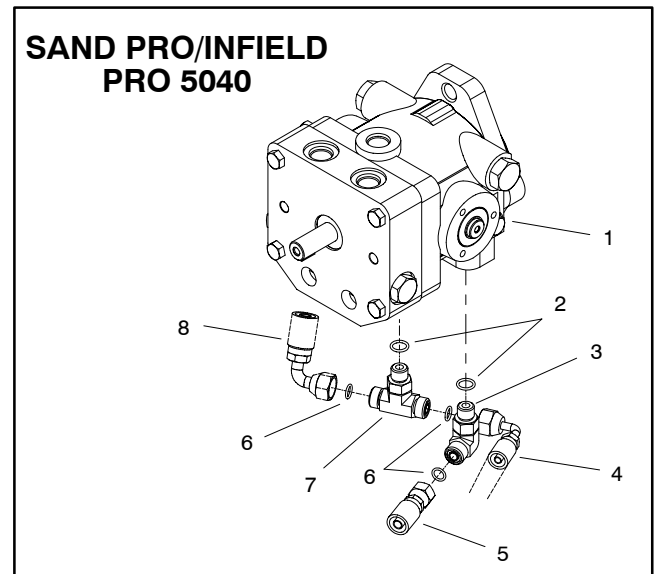

Figure 49

- | | |
|--------------------------|--------------------------|
| 1. Hydrostat | 5. Hydraulic hose |
| 2. O-ring | 6. O-ring |
| 3. 90° hydraulic fitting | 7. Hydraulic Tee fitting |
| 4. Hydraulic hose | 8. Hydraulic hose |

15. Remove hydrostat from machine as follows:

A. Slide hydrostat toward the front of machine to remove hydrostat shaft from pump hub. Take care not to damage the hydrostat coupling.

B. Once the hydrostat shaft is clear of the pump hub, remove hydrostat from the machine.

C. Locate and retrieve square key from the hydrostat shaft.

16. If necessary, loosen two (2) set screws that secure fan hub to hydrostat shaft. Remove fan and fan hub from hydrostat. Locate and retrieve square key from shaft.

17. If hydraulic fittings are to be removed from hydrostat, mark fitting location and orientation to allow correct assembly. Remove fittings from hydrostat.

Installation (Fig. 47)

1. If fittings were removed from hydrostat, install fittings with new o-rings to hydrostat using marks made during the removal process to properly orientate fittings.

2. If fan was removed from hydrostat, apply antiseize lubricant to bore of fan hub. Position key in hydrostat shaft slot and slide fan hub fully onto shaft. Make sure that fan hub shoulder bottoms on shaft. Apply Loctite 242 (or equivalent) to threads of fan hub set screws. Torque both set screws from 90 to 110 in-lb (10.2 to 12.4 N-m) to secure fan to the hydrostat shaft.

IMPORTANT: Make sure not to damage the hydrostat, hydrostat coupling, fuel and hydraulic lines, electrical harness or other parts while installing the hydrostat to the machine.

3. Install hydrostat to machine as follows:

A. Apply antiseize lubricant to bore of pump hub. Place square key into slot on the hydrostat shaft.

B. Align hydrostat shaft to pump hub. Slide hydrostat toward the rear of machine until hydrostat flange holes align with holes in engine support. Take care not to damage the hydrostat coupling.

C. Install two (2) socket head screws and lock nuts to secure hydrostat to engine support.

D. Position pump hub on hydrostat shaft so that rubber pump couplings are not distorted. Pump hub should have a minimum gap of .060" (1.5 mm) to the hydrostat housing.

E. Apply Loctite 242 (or equivalent) to threads of pump hub set screws. Tighten both set screws on the pump hub to secure hub to the hydrostat shaft. Torque set screws from 90 to 110 in-lb (10.2 to 12.4 N-m).

4. Remove plugs and caps placed in hoses and fittings during hydrostat removal.

5. Position new o-rings and correctly connect hydraulic lines to fittings on hydrostat. Use labels placed during the removal process to properly install hoses to hydrostat.

6. Install oil cooler to machine (see Oil Cooler Installation in this section).

7. Secure traction rod to pump lever with cap screw, lock nut and flat washer.

8. Connect traction neutral switch connector to machine wire harness.

9. Install hydraulic oil filter (see Operator's Manual).

10. Fill hydraulic tank with correct hydraulic oil (see Operator's Manual).

11. Operate machine functions slowly until air is out of system (see Charge Hydraulic System in this section).

12. Check and adjust traction neutral position (see Operator's Manual).

13. Check and adjust traction neutral switch (see Operators Manual).

14. Check traction rod adjustment (see Pump Control Assembly in this section). Adjust if necessary.

15. Position center shroud to frame and secure with two (2) cap screws and flat washers (Fig. 48).

This page is intentionally blank.

Hydrostat Service

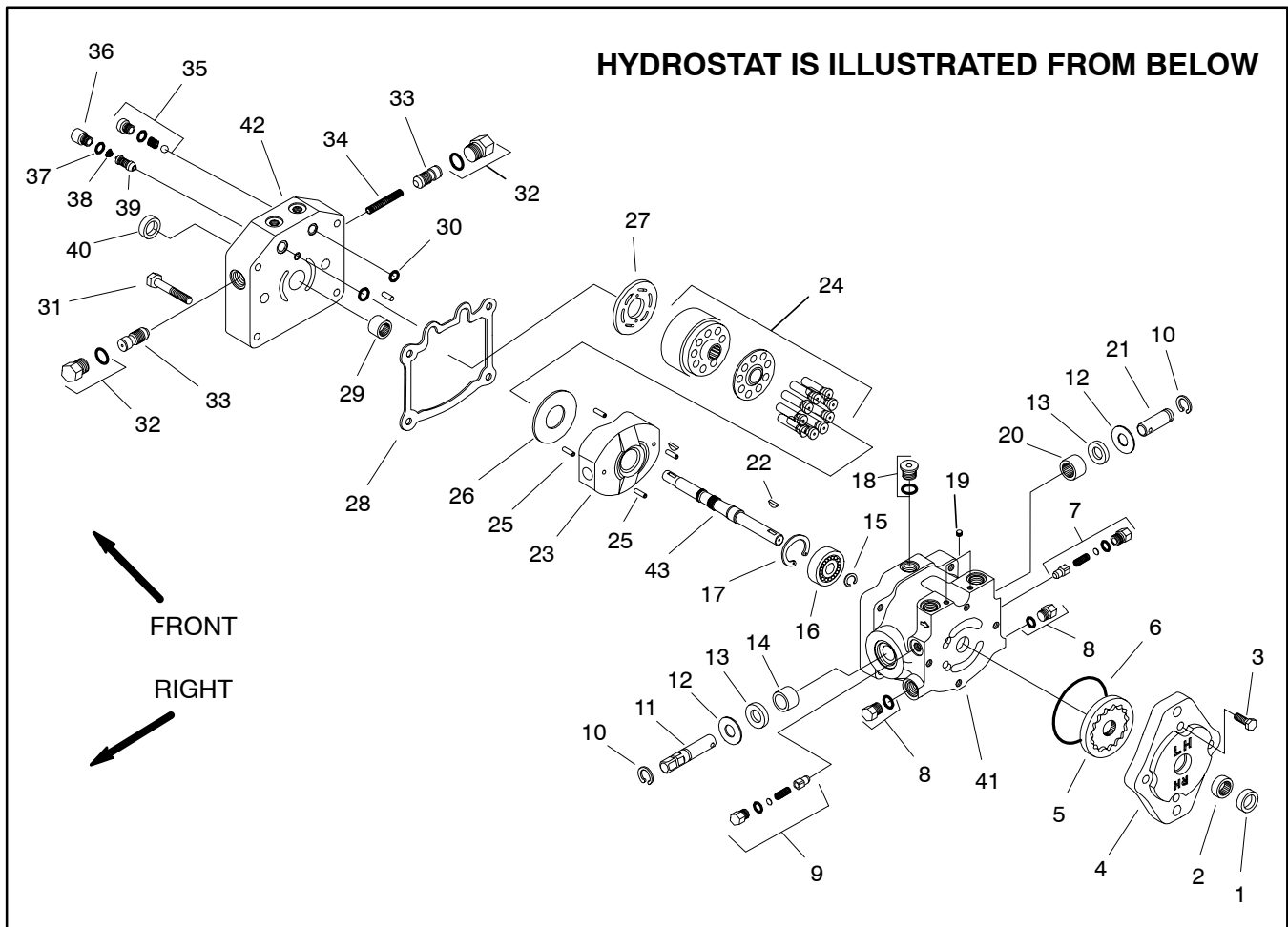

Figure 50

- | | | |
|------------------------------|---------------------------|--|
| 1. Seal | 16. Ball bearing | 30. O-ring (2 used) |
| 2. Needle bearing | 17. Retaining ring | 31. Cap screw (4 used) |
| 3. Cap screw (4 used) | 18. Plug with o-ring | 32. Threaded plug with o-ring (2 used) |
| 4. Charge pump housing | 19. Pipe plug (2 used) | 33. Acceleration valve (2 used) |
| 5. Geroter assembly | 20. Needle bearing | 34. Accelerator valve spring |
| 6. O-ring | 21. Trunnion shaft | 35. Check valve assembly |
| 7. Implement relief valve | 22. Woodruff key (2 used) | 36. Plug |
| 8. Plug with o-ring (2 used) | 23. Swashplate | 37. O-ring |
| 9. Charge relief valve | 24. Cylinder block kit | 38. Spring |
| 10. Retaining ring (2 used) | 25. Spring pin (4 used) | 39. Check relief valve |
| 11. Trunnion shaft | 26. Flat washer | 40. Seal |
| 12. Flat washer (2 used) | 27. Valve plate | 41. Variable housing |
| 13. Seal (2 used) | 28. Gasket | 42. End cap |
| 14. Bearing | 29. Roller bearing | 43. Shaft |

NOTE: For hydrostat repair information, see the Sauer-Danfoss (Sundstrand) 15 Series Repair Manual and Service Manual at the end of this chapter.

This page is intentionally blank.

Lift Cylinder

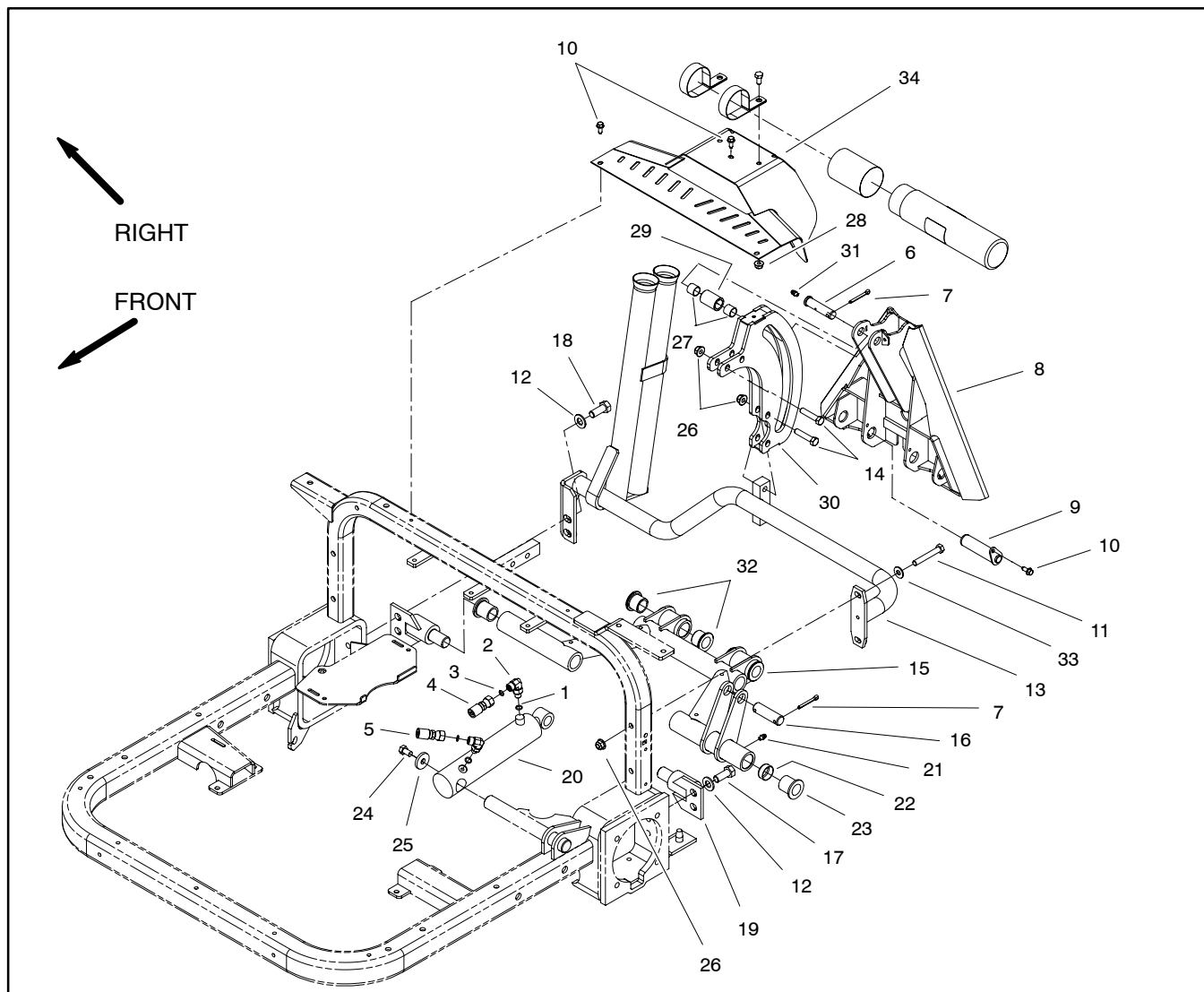

Figure 51

- | | | |
|-----------------------------------|-----------------------------|-----------------------------|
| 1. O-ring | 13. Hitch frame | 24. Cap screw |
| 2. 90° hydraulic fitting (2 used) | 14. Cap screw (4 used) | 25. Flat washer |
| 3. O-ring | 15. Hitch tube | 26. Flange nut |
| 4. Hydraulic hose | 16. Cylinder pin | 27. Bushing |
| 5. Hydraulic hose | 17. Cap screw (2 used) | 28. Flange nut (2 used) |
| 6. Clevis pin | 18. Cap screw (2 used) | 29. Roller tube |
| 7. Cotter pin | 19. Pivot pin (2 used) | 30. Roller plate |
| 8. Hitch adapter | 20. Lift cylinder | 31. Grease fitting |
| 9. Pin (2 used) | 21. Grease fitting (4 used) | 32. Flange bushing (4 used) |
| 10. Washer head screw | 22. Expansion plug (2 used) | 33. Flat washer (2 used) |
| 11. Cap screw (2 used) | 23. Flange bushing (2 used) | 34. Rear cover |
| 12. Lock washer (4 used) | | |

Removal (Fig. 51)

1. Park machine on a level surface, lower attachment, stop engine, apply parking brake and remove key from ignition switch.
2. Read the General Precautions for Removing and Installing Hydraulic System Components at the beginning of the Service and Repairs section of this chapter.
3. Thoroughly clean hydraulic hose ends and fittings on lift cylinder to prevent hydraulic system contamination.
4. Label all hydraulic connections on lift cylinder for assembly purposes.



5. Disconnect hydraulic hoses from lift cylinder. Allow hoses to drain into a suitable container.
6. Put caps or plugs on disconnected hoses and fittings to prevent contamination.
7. Remove cotter pin from one end of cylinder pin (item 16) that secures cylinder clevis to hitch tube. Slide cylinder pin from hitch tube and lift cylinder.

8. Remove cap screw (item 24) and washer (item 25) that secure lift cylinder to frame.

9. Remove lift cylinder from machine.

10. Remove hydraulic fittings from lift cylinder if required. Mark fitting location and orientation to allow correct assembly before removing fittings from lift cylinder.

Installation (Fig. 51)

1. If fittings were removed from lift cylinder, install fittings with new o-rings using marks made during the removal process to properly orientate fittings.

2. Position lift cylinder to frame and hitch tube.

3. Secure lift cylinder to frame with washer and cap screw.

4. Install cylinder pin to secure lift cylinder to hitch tube. Secure cylinder pin with cotter pin.

5. Remove plugs and caps placed in hoses and fittings during removal. Use labels placed during the removal process to properly install hoses to lift cylinder.

6. Make sure hydraulic tank is full. Add correct oil if necessary (see Operator's Manual).

7. Operate machine functions slowly until air is out of system (see Charge Hydraulic System in this section).

Lift Cylinder Service

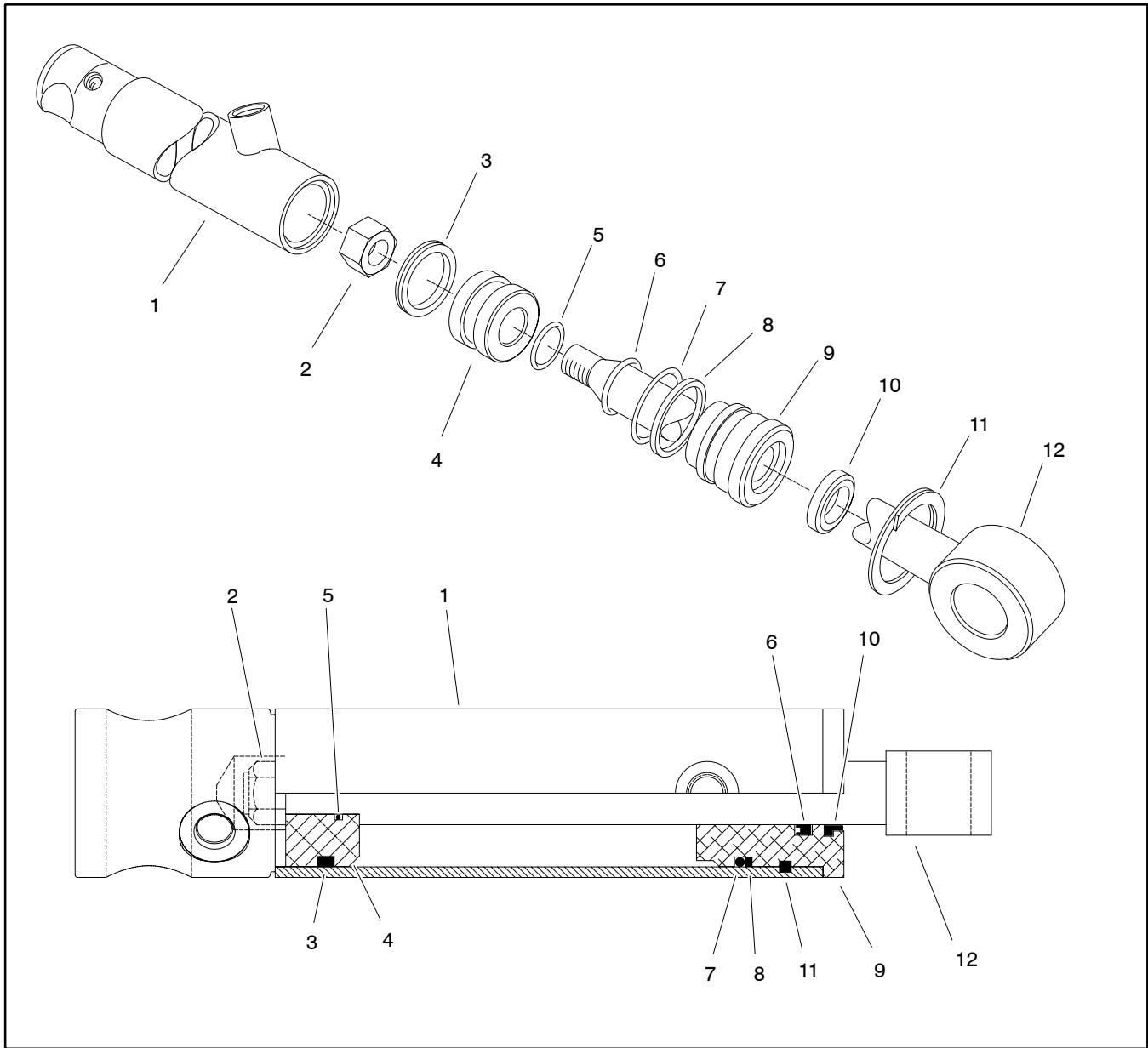

Figure 52

- 1. Barrel
- 2. Nut
- 3. Seal
- 4. Piston

- 5. O-ring
- 6. Rod seal
- 7. O-ring
- 8. Backup seal

- 9. Head
- 10. Dust seal
- 11. Retaining ring
- 12. Shaft

Disassembly (Fig. 52)

1. Remove oil from lift cylinder into a drain pan by slowly pumping the cylinder shaft. Plug both ports and clean the outside of the cylinder.

IMPORTANT: Prevent damage when clamping the lift cylinder into a vise; clamp on the clevis end of the barrel ONLY.

2. Mount lift cylinder securely in a vise by clamping on the clevis end of the barrel.

3. Using a spanner wrench, rotate head clockwise until the edge of the retaining ring appears in the barrel opening. Insert a screwdriver under the beveled edge of the retaining ring to start the retaining ring through the opening. Rotate the head counter-clockwise to remove retaining ring from barrel and head.

4. Remove plugs from ports. Extract shaft, head and piston by carefully twisting and pulling on the shaft.

IMPORTANT: Do not clamp vise jaws against the shaft surface. Clamp on the clevis ONLY.

5. Mount shaft securely in a vise by clamping on the clevis of the shaft. Remove lock nut and piston from the shaft. Carefully slide head off the shaft.

6. Taking care to not scratch or damage the piston, remove seal and o-ring from the piston.

7. Taking care to not scratch or damage the head, remove o-ring, back-up seal, rod seal and dust seal from the head.

Assembly (Fig. 52)

1. Make sure all cylinder parts are clean before assembly.

2. Coat new o-rings, back-up ring and other seals with clean hydraulic oil.

A. Carefully install seal and o-ring to the piston.

B. Carefully install rod seal, o-ring, back-up seal and dust seal to the head.

IMPORTANT: Do not clamp vise jaws against the shaft surface. Clamp on the clevis ONLY.

3. Mount shaft securely in a vise by clamping on the clevis of the shaft.

A. Coat shaft with clean hydraulic oil.

B. Slide head onto the shaft.

C. Install piston onto the shaft and secure with nut.

D. Remove shaft assembly from the vise.

IMPORTANT: Prevent damage when clamping the hydraulic cylinder into a vise; clamp on the clevis end of the barrel ONLY.

4. Mount barrel securely in a vise by clamping on the clevis end of the barrel.

IMPORTANT: When installing the head into the barrel, pay careful attention to the retaining ring slot in the barrel to insure that the backup ring does not lodge in the slot.

5. Coat all internal parts with a light coat of clean hydraulic oil. Slide piston, shaft and head assembly into the barrel being careful not to damage the seals.

6. Secure head in barrel by installing retaining ring. Align retaining ring hole in the head with the access slot in the barrel. Insert the retaining ring hook into the hole and rotate head clockwise until the retaining ring is completely pulled into the barrel and the ring ends are covered.

Steering Control Valve (Sand Pro 5040 and Infield Pro 5040)

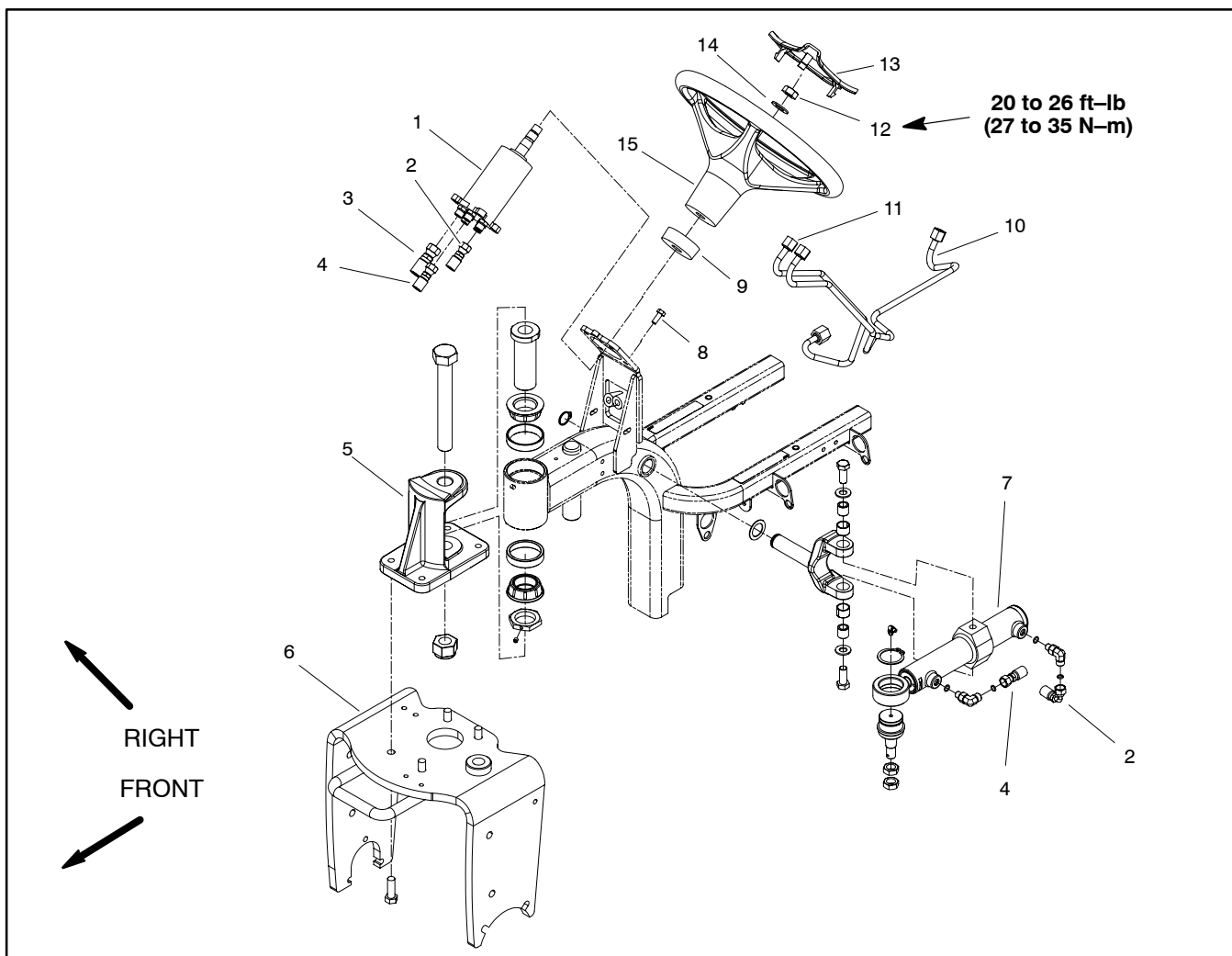

Figure 53

1. Steering control valve
2. Hydraulic hose
3. Hydraulic hose
4. Hydraulic hose
5. Steering pivot

6. Castor fork
7. Steering cylinder
8. Cap screw (4 used)
9. Foam collar
10. Hydraulic tube

11. Hydraulic tube
12. Lock nut
13. Steering wheel cover
14. Flat washer
15. Steering wheel

Removal (Fig. 53)

1. Park machine on a level surface, lower attachment, stop engine, apply parking brake and remove key from ignition switch.

2. Remove fuel tank from machine (see Fuel Tank Removal in the Service and Repairs section of Chapter 3 – Engine).

3. Read the General Precautions for Removing and Installing Hydraulic System Components at the beginning of the Service and Repairs section of this chapter.

4. Thoroughly clean hydraulic hose ends and fittings on steering control valve to prevent hydraulic system contamination.

5. Label all hydraulic connections at steering control valve for assembly purposes. Note port designations on steering control valve (Fig. 54).



CAUTION

Operate all hydraulic controls to relieve system pressure and avoid injury from pressurized hydraulic oil.

6. Disconnect hydraulic hoses and tubes from steering control valve. Allow hoses and tubes to drain into a suitable container.

7. Put caps or plugs on disconnected hoses, tubes and fittings to prevent contamination.
8. Remove steering wheel from machine:
 - A. Remove cover from steering wheel.
 - B. Loosen and remove nut that secures steering wheel to steering control valve. Remove flat washer from control valve shaft.
 - C. Slide steering wheel and foam collar from steering control valve.
9. Support steering control valve to prevent it from falling during removal.
10. Loosen and remove four (4) cap screws that secure steering control valve to machine.
11. Remove steering control valve from machine.

Installation (Fig. 53)

1. Position steering control valve to frame. Secure steering control valve to steering column with four (4) cap screws.
2. Remove caps and plugs from disconnected hoses, tubes and fittings.
3. Lubricate new o-rings and connect hydraulic hoses and tubes to steering control valve (Fig. 55). Use labels placed during the removal process to properly install hoses and tubes to steering control valve. Tighten connections.
4. Slide foam collar and steering wheel onto steering control valve shaft and secure with flat washer and lock nut. Torque lock nut 20 to 26 ft-lb (27 to 35 N-m). Install cover.
5. Install fuel tank to machine (see Fuel Tank Installation in the Service and Repairs section of Chapter 3 – Engine).
6. Check hydraulic fluid level in tank and adjust as required (see Traction Unit Operator's Manual).
7. Operate machine functions slowly until air is out of system (see Charge Hydraulic System in this section).
8. Rotate steering wheel to verify that hydraulic hoses and fittings are not contacted by anything and that there are no leaks.

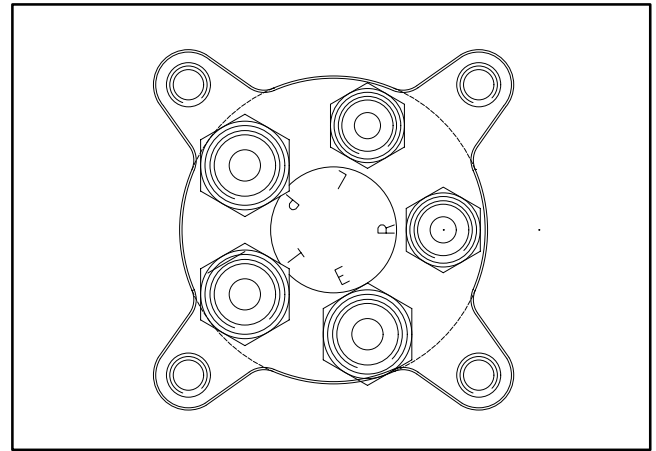

Figure 54

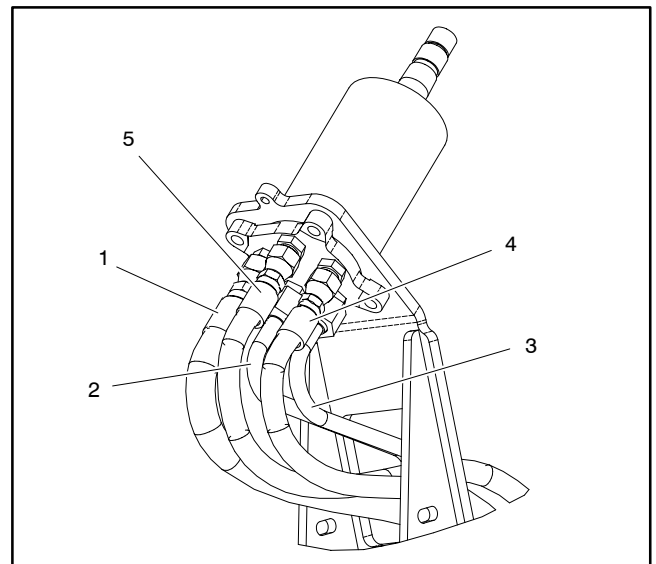

Figure 55

1. Hose from hydrostat (Port P)
2. Tube to oil cooler Tee fitting (Port T)
3. Tube to lift control Tee fitting (Port E)
4. Hose to steering cylinder barrel end (Port R)
5. Hose to steering cylinder rod end (Port L)

Steering Control Valve Service (Sand Pro 5040 and Infield Pro 5040)

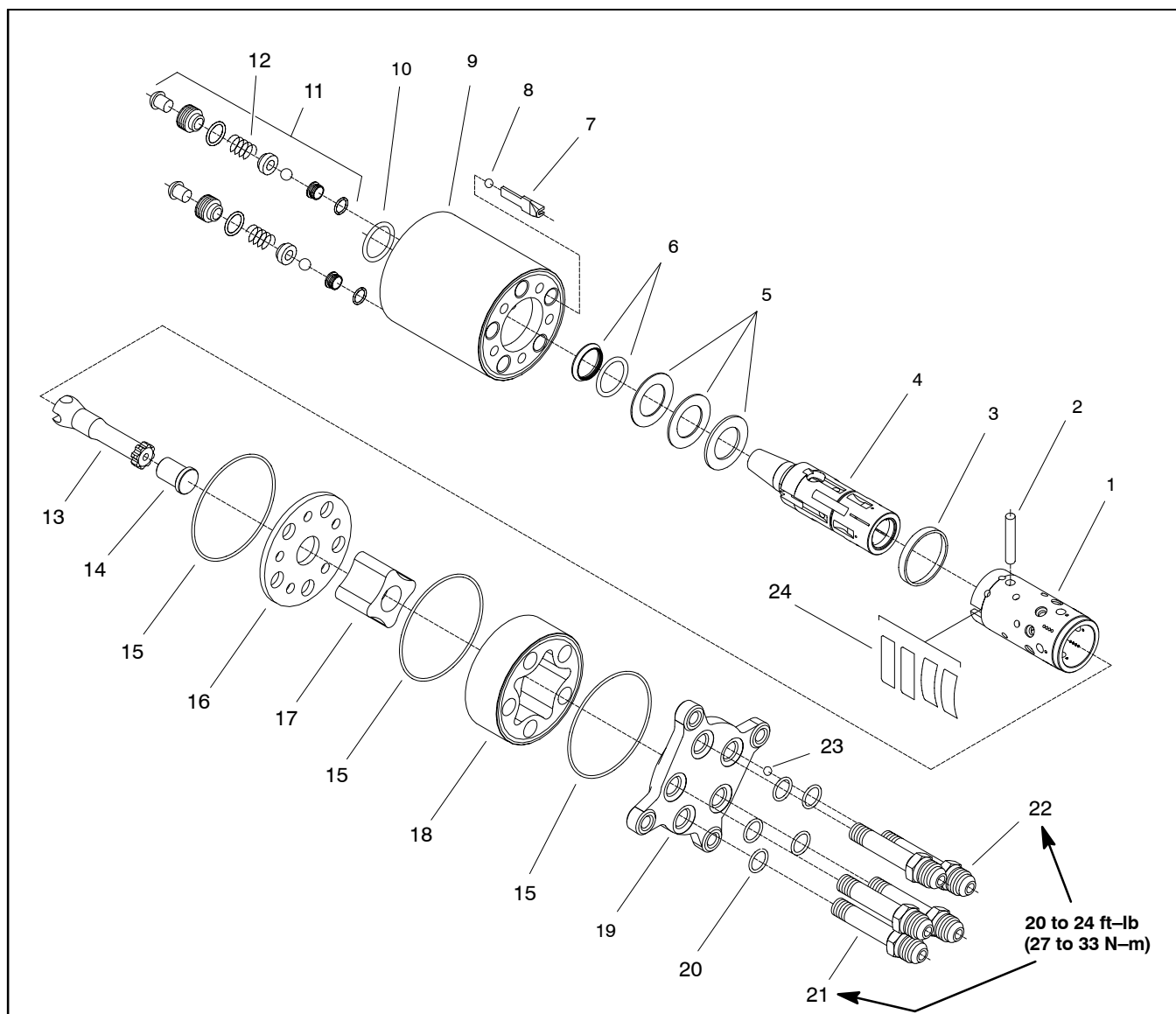

Figure 56

- | | | |
|---------------------|----------------------------------|-----------------------------------|
| 1. Sleeve | 9. Housing | 17. Inner gearwheel |
| 2. Cross pin | 10. Dust seal ring | 18. Outer gearwheel |
| 3. Ring | 11. Relief valve (2 used) | 19. End cover |
| 4. Spool | 12. Relief valve spring (2 used) | 20. O-ring (5 used) |
| 5. Bearing assembly | 13. Cardan shaft | 21. Screw/fitting (ports L, R, T) |
| 6. Shaft seal | 14. Spacer | 22. Screw/fitting (ports P and E) |
| 7. Ball stop | 15. O-ring | 23. P port check ball |
| 8. Ball | 16. Distribution plate | 24. Spring set |

NOTE: For repair of the steering control valve used on Sand Pro 5040 and Infield Pro 5040 machines, see the Sauer-Danfoss Steering Unit Type OSPM Service Manual at the end of this chapter.

This page is intentionally blank.

Steering Cylinder (Sand Pro 5040 and Infield Pro 5040)

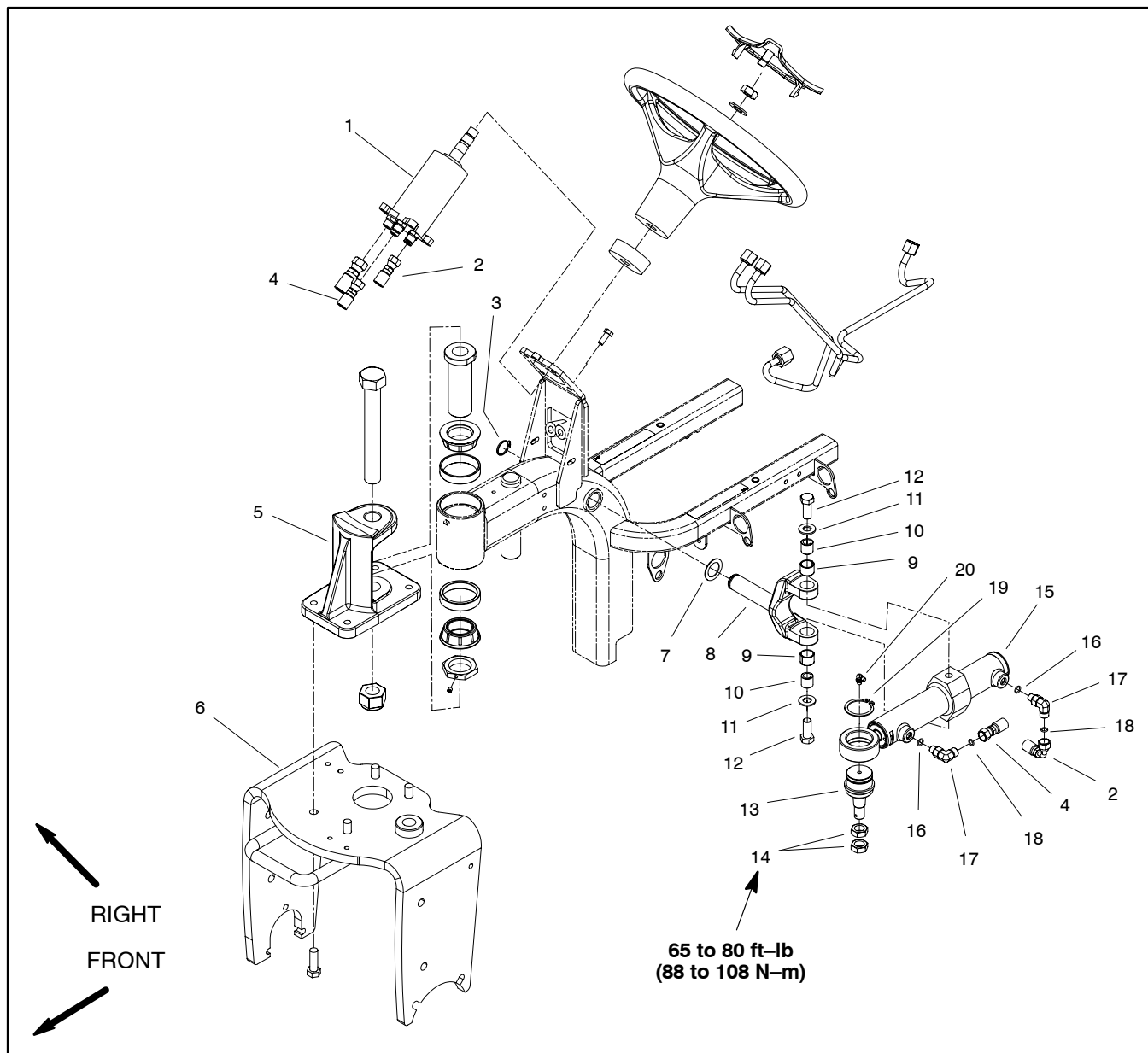

Figure 57

- 1. Steering control valve
- 2. Hydraulic hose
- 3. Retaining ring
- 4. Hydraulic hose
- 5. Steering pivot
- 6. Castor fork
- 7. Flat washer

- 8. Yoke
- 9. Bushing
- 10. Spacer
- 11. Flat washer
- 12. Cap screw
- 13. Ball joint
- 14. Jam nut

- 15. Steering cylinder
- 16. O-ring
- 17. 90° hydraulic fitting
- 18. O-ring
- 19. Retaining ring
- 20. Grease fitting

Removal (Fig. 57)

1. Park machine on a level surface, lower attachment, stop engine, apply parking brake and remove key from ignition switch.
2. Thoroughly clean hydraulic hose ends and fittings on steering cylinder to prevent hydraulic system contamination.
3. Label all hydraulic connections for assembly purposes.



4. Disconnect hydraulic hoses from steering cylinder.
5. Put caps or plugs on disconnected hoses and fittings to prevent contamination.
6. Remove two (2) jam nuts that secure steering cylinder balljoint to front castor fork. Separate steering cylinder ball joint from front fork.
7. Loosen and remove two (2) cap screws and flat washers that secure steering cylinder to yoke. Locate and retrieve spacers.
8. Remove steering cylinder from machine.
9. If needed, remove ball joint from steering cylinder.
10. Remove hydraulic fittings from steering cylinder if required. Note orientation of fittings before removing from steering cylinder.

Installation (Fig. 57)

1. Coat new o-rings lightly with clean hydraulic oil.
2. If fittings were removed from steering cylinder, install fittings with new o-rings to cylinder using notes made during the removal process to properly orientate fittings.
3. If removed, press balljoint into steering cylinder and secure with retaining ring.
4. Thoroughly clean taper of balljoint and balljoint boss in front castor fork.
5. Position steering cylinder to front castor fork and yoke.
6. Secure steering cylinder balljoint to front castor fork with two (2) jam nuts. Install first jam nut onto cylinder balljoint threads and torque from 65 to 80 ft-lb (88 to 108 N-m). Then, while retaining first jam nut with wrench, install and torque second jam nut from 65 to 80 ft-lb (88 to 108 N-m).
7. Secure steering cylinder to yoke with two (2) cap screws, spacers and flat washers.
8. Remove plugs and caps placed in hoses and fittings during removal. Use labels placed during the removal process to properly install hoses to steering cylinder fittings.
9. Make sure hydraulic tank is full. Add correct oil if necessary (see Operator's Manual).
10. Grease steering cylinder balljoint (see Operator's Manual).
11. Operate machine functions slowly until air is out of system (see Charge Hydraulic System in this section).

Steering Cylinder Service (Sand Pro 5040 and Infield Pro 5040)

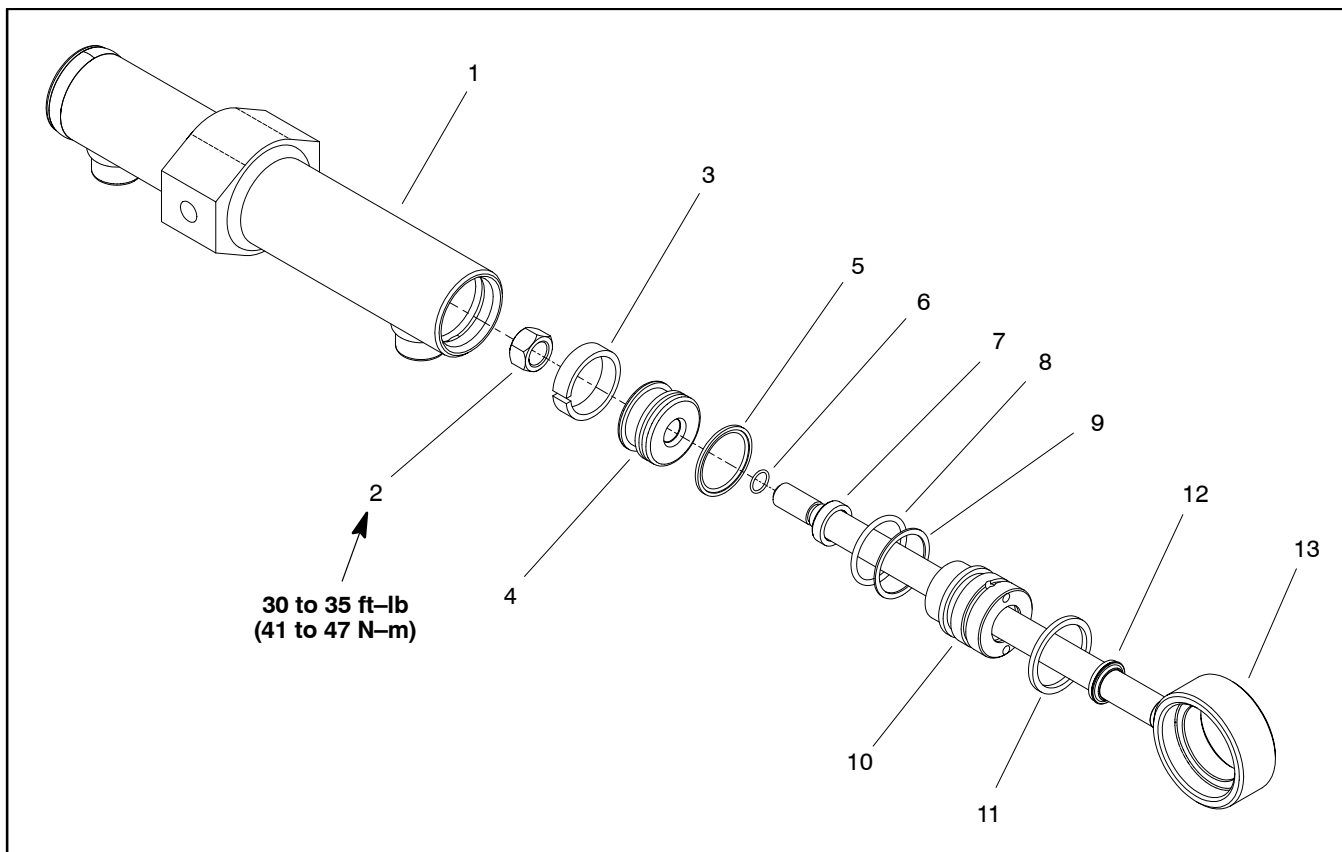

Figure 58

- | | | |
|--------------|-----------------|--------------------|
| 1. Barrel | 6. O-ring | 10. Head |
| 2. Lock nut | 7. Rod seal | 11. Retaining ring |
| 3. Wear ring | 8. O-ring | 12. Wiper |
| 4. Piston | 9. Back-up ring | 13. Cylinder rod |
| 5. Seal | | |

Disassembly (Fig. 58)

1. Remove oil from steering cylinder into a drain pan by slowly pumping the cylinder shaft. Plug both ports and clean the outside of the cylinder.

2. Secure steering cylinder in a vise by lightly clamping on the mounting collar on the barrel.

3. Remove retaining ring from head and barrel using the following procedure:

A. Using a spanner wrench, rotate head clockwise until the edge of the retaining ring appears in the barrel opening.

B. Insert a screwdriver under the beveled edge of the retaining ring to start the retaining ring through the barrel opening.

C. Rotate the head counter-clockwise to fully remove retaining ring.

4. Remove plugs from ports. Extract shaft, head and piston by carefully twisting and pulling on the shaft.

IMPORTANT: Do not clamp vise jaws against the shaft surface. Clamp on the clevis ONLY.

5. Mount shaft securely in a vise by clamping on the clevis of the shaft. Remove lock nut and piston from the shaft. Carefully slide head off the shaft.

6. Taking care to not scratch or damage the piston, remove wear ring, seal and o-ring from the piston.

7. Taking care to not scratch or damage the head, remove o-ring, back-up ring, rod seal and wiper from the head.

Assembly (Fig. 58)

1. Make sure all cylinder parts are clean before assembly.

2. Coat new o-rings, back-up ring and other seals with clean hydraulic oil.

A. Carefully install wear ring, seal and o-ring to the piston.

B. Carefully install rod seal, o-ring, back-up ring and wiper to the head.

IMPORTANT: Do not clamp vise jaws against the shaft surface. Clamp on the clevis ONLY.

3. Mount shaft securely in a vise by clamping on the clevis of the shaft.

A. Coat shaft with clean hydraulic oil.

B. Slide head onto the shaft.

C. Install piston onto the shaft and secure with lock nut. Torque lock nut from 30 to 35 ft-lb (41 to 47 N-m).

D. Remove shaft assembly from the vise.

IMPORTANT: Prevent damage when clamping the hydraulic cylinder into a vise; clamp on the mounting collar on the barrel ONLY.

4. Mount barrel securely in a vise by lightly clamping on the mounting collar on the barrel.

5. Coat all internal parts with a light coat of clean hydraulic oil. Slide piston, shaft and head assembly into the barrel being careful not to damage the seals.

IMPORTANT: When installing the head into the barrel, pay careful attention to the retaining ring slot in the barrel to insure that the backup ring does not lodge in the slot.

6. Install retaining ring to secure head in the barrel using the following procedure:

A. Using a spanner wrench, rotate head until the retaining ring hole appears in the barrel opening.

B. Insert the retaining ring hook into the hole.

C. Rotate the head clockwise 1 1/4 turns until the retaining ring is completely pulled into the barrel and the ends are covered.

This page is intentionally blank.



Table of Contents

ELECTRICAL SCHEMATIC AND DRAWINGS 2
SPECIAL TOOLS 2
TROUBLESHOOTING 4
 Starting Problems 4
 General Run Problems 5
ELECTRICAL SYSTEM QUICK CHECKS 7
 Battery Test (Open Circuit Test) 7
 Charging System Test 7
COMPONENT TESTING 8
 Ignition Switch 8
 Starter Solenoid 9
 Hour Meter 10
 Diode Assemblies 10
 Charge, Start and Interlock Relays 11
 Seat Switch 12
 Traction Neutral Switch 13
SERVICE AND REPAIRS 14
 Battery Storage 14
 Battery Care 14
 Battery Service 15

Electrical System

Electrical Schematic and Drawings

The electrical schematic, circuit diagrams and wire harness drawings for the Sand Pro and Infield Pro are located in Chapter 7 – Electrical Diagrams.

Special Tools

Multimeter

The multimeter can test electrical components and circuits for current (amps), resistance (ohms) or voltage. Obtain this tool locally.

NOTE: Toro recommends the use of a DIGITAL Volt-Ohm-Amp multimeter when testing electrical circuits. The high impedance (internal resistance) of a digital meter in the voltage mode will make sure that excess current is not allowed through the meter. This excess current can cause damage to circuits not designed to carry it.

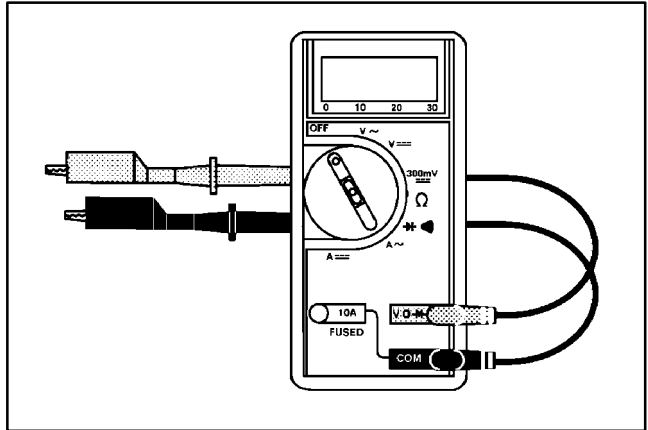

Figure 1

Skin-Over Grease

Part Number: 505-165

Special non-conductive grease which forms a light protective skin to help waterproof electrical switches and connections.



Figure 2

Battery Terminal Protector

Part Number: **107-0392**

Battery Terminal Protector is an aerosol spray that should be used on battery terminals to reduce corrosion problems. Apply terminal protector after battery cable has been secured to battery terminal.



Figure 3

Battery Hydrometer

Use the Battery Hydrometer when measuring specific gravity of battery electrolyte. Obtain this tool locally.



Figure 4

Spark Tester

Part Number: **TOR4036**

The spark tester can be used to test magneto ignitions. The spark tester determines if ignition is present.

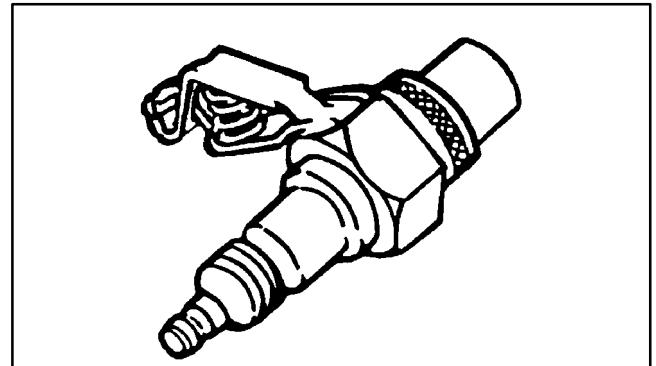

Figure 5

Troubleshooting



CAUTION

Remove all jewelry, especially rings and watches, before doing any electrical testing or troubleshooting.

NOTE: See the Briggs and Stratton Repair Manual at the end of Chapter 3 – Engine for troubleshooting of engine electrical components.

If the machine has any interlock switches by-passed, they must be reconnected for proper troubleshooting and safety.

For effective troubleshooting and repairs, there must be a good understanding of the electrical circuits and components used on this machine (see Electrical Schematics and Circuit Diagrams in Chapter 7 – Electrical Diagrams).

Starting Problems

Problem	Possible Causes
Starter solenoid clicks, but starter will not crank (if starter solenoid clicks, problem is not in safety interlock system).	Battery is discharged or faulty. Battery cables are loose or corroded. Ground connection to frame is loose or corroded. Cable connection at starter is faulty. Starter solenoid is faulty. Starter motor mounting bolts are loose or not supplying a sufficient ground for starter operation. Engine starter motor is faulty.
Nothing happens when start attempt is made.	Traction pedal not in neutral position. Traction neutral switch is out of adjustment or faulty. Battery is discharged or faulty. Battery cables are loose or corroded. Wiring to starting circuitry components is loose, corroded or damaged (see Wiring Schematics in Chapter 7 – Electrical Diagrams). Ground connection to frame is loose or corroded. Fuse F1 (15 amp) is open, loose or missing. Fuse F2 (10 amp) is open, loose or missing. Start relay is faulty. Fusible link to starter solenoid is open. Fuse block is faulty. Ignition switch is faulty. Starter solenoid is faulty.

Starting Problems (continued)

Problem	Possible Causes
Engine cranks, but does not start.	Wiring to interlock components is loose, corroded or damaged (see Circuit Diagrams in Chapter 7 – Electrical Diagrams). Diode D2 is faulty. Interlock relay is faulty. Engine is out of fuel or may be too cold. Ignition switch is faulty. Engine fuel solenoid is faulty. Spark plugs are faulty. Engine or fuel system is malfunctioning (see Chapter 3 – Gasoline Engine).
Engine cranks slowly.	Battery is discharged or faulty. Battery cables are loose or corroded. Engine is too cold.

General Run Problems

Problem	Possible Causes
Engine stops when traction pedal is pressed.	Operator seat is not occupied. Diode D1 is faulty. Seat switch is faulty. Wiring to interlock components is loose, corroded or damaged (see Circuit Diagrams in Chapter 7 – Electrical Diagrams).

General Run Problems (Continued)

Problem	Possible Causes
Battery does not charge.	Wiring to charging circuit components is loose, corroded or damaged (see Wiring Schematics in Chapter 7 – Electrical Diagrams). Voltage regulator is not grounded or is faulty. Alternator stator is faulty. Fuse F1 (15 amp) is open, loose or missing. Charge relay is faulty. Fusible link to starter solenoid is open. Ignition switch is faulty. Battery is discharged or faulty.

Electrical System Quick Checks

Battery Test (Open Circuit Test)

Use a multimeter to measure the voltage between the battery terminals.

Tool required: Digital multimeter set to DC volts.

Test instructions: The battery should be at a temperature of 60° to 100°F (16° to 38°C). The ignition key should be off and all accessories turned off. Connect the positive (+) meter lead to the positive battery post and the negative (-) meter lead to the negative battery post. Measure and record the battery voltage.

NOTE: This test provides a relative condition of the battery. Load testing of the battery will provide additional and more accurate information (see Battery Service in the Service and Repairs section of this chapter).

Voltage Measured	Battery Charge Level
12.68 V (or higher)	Fully charged (100%)
12.45 V	75% charged
12.24 V	50% charged
12.06 V	25% charged
11.89 V	0% charged

Charging System Test

This is a simple test used to determine if the charging system is functioning. It will tell you if the charging system has an output, but not its capacity.

Tool required: Digital multimeter set to DC volts.

Test instructions: Connect the positive (+) multimeter lead to the positive battery post and the negative (-) multimeter lead to the negative battery post. Keep the test leads connected to the battery posts and record the battery voltage.

NOTE: Battery voltage must be greater than 5 VDC for the alternator system to have any output. If battery voltage is less than 5 VDC, charge battery before performing charging system test.

NOTE: Upon starting the engine, the battery voltage will drop and then should increase once the engine is running.

NOTE: Depending upon the condition of the battery charge and battery temperature, the charging system voltage will increase at different rates as the battery charges.

Start the engine and run at high idle (**3400 RPM**). Allow the battery to charge for at least 3 minutes. Record the battery voltage.

After running the engine for at least 3 minutes, battery voltage should be at least 0.50 volt higher than initial battery voltage.

Example of a charging system that is functioning:

At least 0.50 volt over initial battery voltage.	
Initial Battery Voltage	= 12.30 v
Battery Voltage after 3 Minute Charge	= 12.85 v
Difference	= +0.55 v

Component Testing

For accurate resistance and/or continuity checks, electrically disconnect the component being tested from the circuit (e.g. unplug the ignition switch connector before checking continuity between switch terminals).

Ignition Switch

The ignition (key) switch has three positions (OFF, RUN, and START) (Fig. 6). The switch terminals are identified as shown in Figure 7.

Testing

The circuitry of the ignition switch is shown in the chart below. With the use of a multimeter (ohms setting), the switch functions may be tested to determine whether continuity exists between the various terminals for each switch position.

Unplug wire harness connector from switch and verify continuity between switch terminals. Reconnect the harness connector to the switch after testing.

POSITION	CIRCUIT
OFF	G + M + A
RUN	B + L + A
START	B + L + S

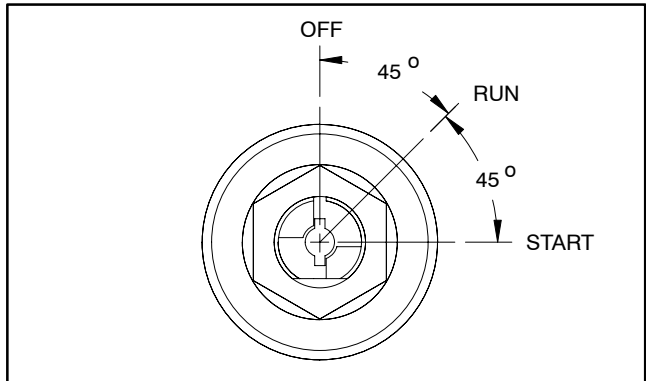

Figure 6

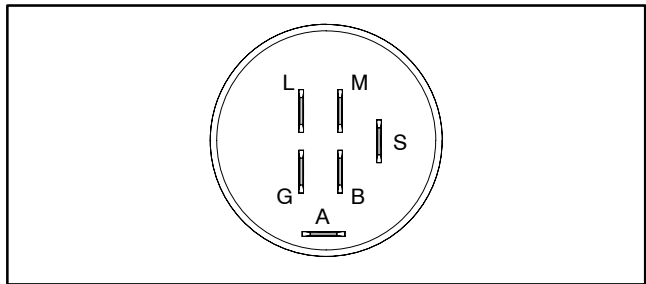

Figure 7

Starter Solenoid

The engine starter solenoid is attached to a bracket above the battery. When energized, the starter solenoid allows current flow from the battery to the engine starter motor.

Testing

1. Park machine on a level surface, lower attachment, stop engine, apply parking brake and remove key from ignition switch.
2. Tilt operator seat up to gain access to starter solenoid.
3. Disconnect negative battery cable from battery and then disconnect positive battery cable.
4. Disconnect wires from starter solenoid (Fig. 8).
5. Apply 12 VDC directly across the solenoid coil posts (Fig. 9). The solenoid should click as it is energized. While energized, resistance across the main contact posts should be less than 1 ohm (continuity).
6. Remove voltage from solenoid coil posts. The solenoid should click as it de-energizes. Make sure resistance across the main contact posts is infinite ohms (no continuity).
7. Replace starter solenoid if necessary.
8. Reconnect wires to starter solenoid. Torque nuts on coil posts from 15 to 20 in-lb (1.7 to 2.3 N-m) and nuts on main contact posts from 50 to 60 in-lb (5.7 to 6.8 N-m).
9. Connect positive battery cable to battery first and then attach negative battery cable.
10. Lower operator seat.

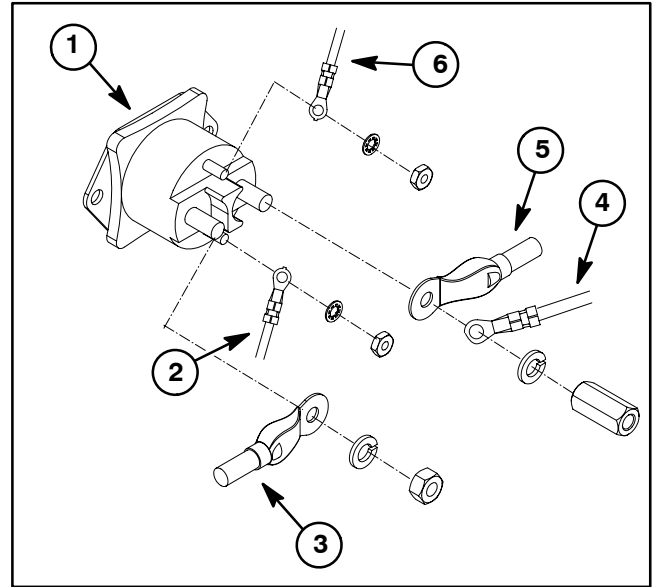

Figure 8

- | | |
|-----------------------|---------------------------|
| 1. Starter solenoid | 4. Harness fusible link |
| 2. Harness brown wire | 5. Positive battery cable |
| 3. Starter cable | 6. Harness black wire |

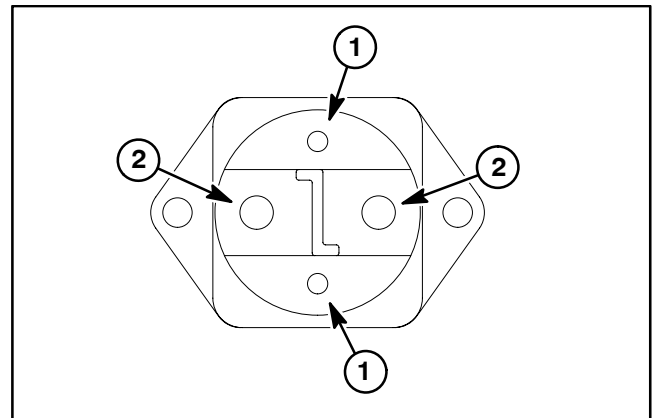

Figure 9

- | | |
|--------------|----------------------|
| 1. Coil post | 2. Main contact post |
|--------------|----------------------|

Hour Meter

The hour meter used on the machine records the amount of time that the ignition switch is in the ON position.

Testing

1. Remove knob from lift lever.
2. Remove four (4) screws and flat washers that secure control panel to console (Fig. 10). Lift control panel, unplug wire harness connector from hour meter and remove control panel from machine.
3. Connect the positive (+) terminal of a 12 VDC source to the positive (+) terminal of the hour meter.
4. Connect the negative (-) terminal of the voltage source to the other terminal of the hour meter.
5. The hour meter should move 1/10 of an hour in six minutes.
6. Disconnect the voltage source from the hour meter.
7. Connect wire harness connector to hour meter and position control panel to console. Secure control panel with four (4) screws and flat washers (Fig. 10).
8. Install knob to lift lever.

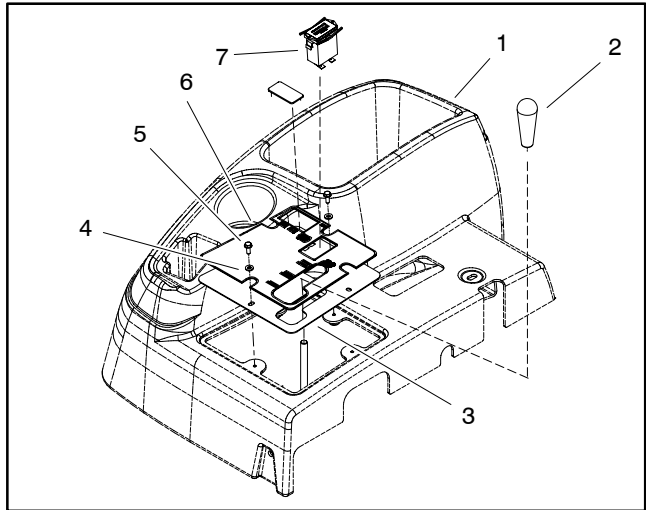

Figure 10

- | | |
|-------------------------|-------------------|
| 1. Console | 5. Screw (4 used) |
| 2. Lift lever knob | 6. Panel decal |
| 3. Control panel | 7. Hour meter |
| 4. Flat washer (4 used) | |

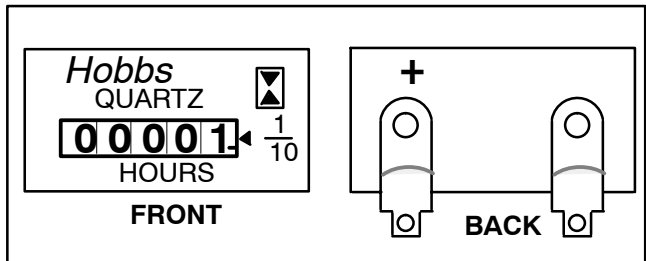

Figure 11

Diode Assemblies

Diodes D1 and D2 provide logic for the interlock system. The diodes plug into the wiring harness under the console control panel.

Testing

The diode (Fig. 12) can be tested using a digital multimeter (diode test or ohms setting) and the table **below**.

Multimeter Red Lead (+) on Terminal	Multimeter Black Lead (-) on Terminal	Continuity
Female	Male	YES
Male	Female	NO

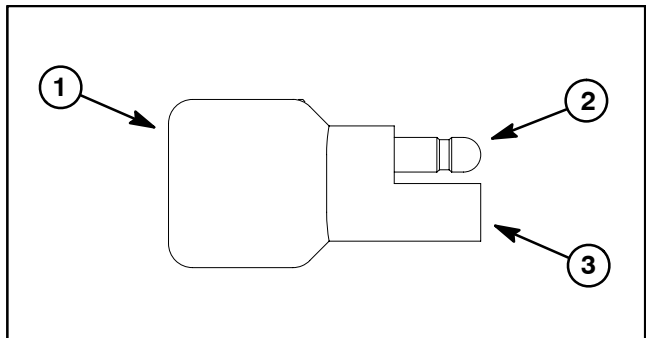

Figure 12

- | | |
|------------------|--------------------|
| 1. Diode | 3. Female terminal |
| 2. Male terminal | |

Charge, Start and Interlock Relays

Three (3) relays are used on the machine: start relay, charge relay and interlock relay. The relays are attached to a bracket under the seat (Fig. 13). The relays are identical and are identified by a tag on the wire harness relay connector.

The start relay is used in the starting circuit. When energized, the start relay provides current to energize the starter solenoid.

When the charge relay is energized, a circuit from the alternator to the battery is completed to allow battery charging.

The interlock relay is used in conjunction with the seat switch, the neutral switch and diodes D1 and D2 to form the interlock system on the machine. When the interlock relay is energized, the engine magneto system will function. During operation, if the interlock relay should be de-energized (e.g. operator rises out of the seat with the traction pedal depressed), the magneto will be grounded and the engine will stop.

Testing

NOTE: Prior to taking small resistance readings with a digital multimeter, short the meter test leads together. The meter will display a small resistance value (usually 0.5 ohms or less). This resistance is due to the internal resistance of the meter and test leads. Subtract this value from the measured value of the component you are testing.

1. Park machine on a level surface, lower attachment, stop engine, apply parking brake and remove key from ignition switch.
2. Tilt operator seat up to gain access to relays.
3. Locate relay to be tested. Disconnect the machine wire harness connector from the relay.
4. Using a multimeter (ohms setting), measure coil resistance between terminals 85 and 86 (Fig. 14). Resistance should be between 70 and 90 ohms.
5. Connect multimeter (ohms setting) leads to relay terminals 30 and 87. Ground terminal 86 and apply +12 VDC to terminal 85. The relay should make and break continuity between terminals 30 and 87 as +12 VDC is applied and removed from terminal 85.
6. Disconnect voltage from terminal 85 and multimeter lead from terminal 87.

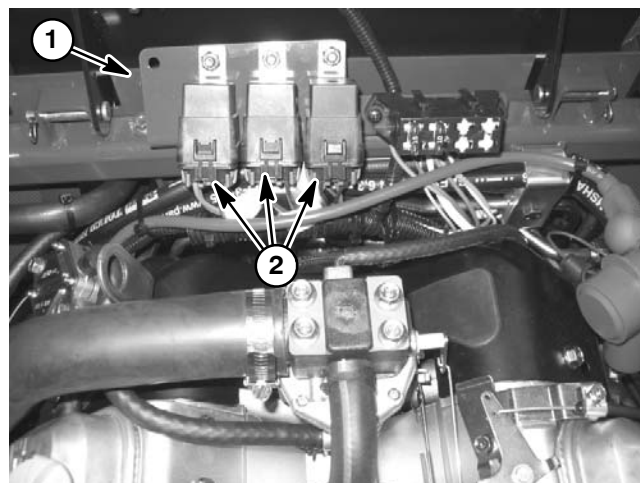

Figure 13

1. Bracket
2. Relay

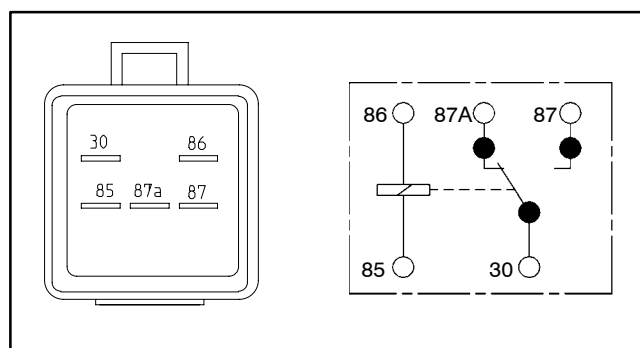

Figure 14

7. Connect multimeter (ohms setting) leads to relay terminals 30 and 87A. Apply +12 VDC to terminal 85. The relay should make and break continuity between terminals 30 and 87A as +12 VDC is applied and removed from terminal 85.
8. Disconnect voltage and multimeter leads from the relay terminals. Connect machine wire harness connector to relay.
9. Lower operator seat.

Seat Switch

The seat switch is normally open and closes when the operator is occupying the seat. The seat switch is located directly under the seat. If the operator leaves the seat, the engine will stop unless the traction pedal is in the neutral position.

The closed seat switch (seat occupied) and diode D1 keep the interlock relay energized and the engine running when the traction pedal is depressed.

Testing

1. Park machine on a level surface, lower attachment, stop engine, apply parking brake and remove key from ignition switch.
2. Tilt up operator seat and locate seat switch for testing.
3. Disconnect harness electrical connector from the seat switch.
4. Check the continuity of the switch by connecting a multimeter (ohms setting) across the switch terminals.
5. With no pressure on the seat, there should be no continuity between the seat switch terminals.
6. Press directly onto the seat switch through the seat cushion. There should be continuity as the seat cushion approaches the bottom of its travel.
7. Connect harness electrical connector to seat switch after testing.
8. Lower operator seat.

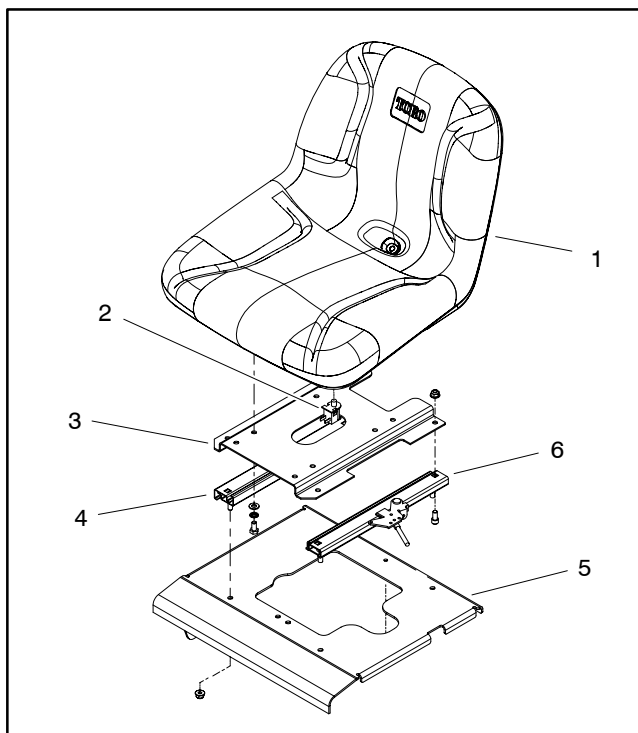

Figure 15

- | | |
|------------------|---------------------|
| 1. Operator seat | 4. RH seat adjuster |
| 2. Seat switch | 5. Seat shroud |
| 3. Seat base | 6. LH seat adjuster |

Traction Neutral Switch

The traction neutral switch is a normally open proximity switch that closes when the traction pedal is in the neutral position. The switch is attached to the hydrostat pump plate (Fig. 16). A cap screw located on the neutral arm acts as the sensing plate for the switch.

Testing

1. Park machine on a level surface, lower attachment, stop engine, apply parking brake and remove key from ignition switch.
2. Remove center shroud to allow access to traction neutral switch (Fig. 17).
3. Locate traction neutral switch for testing.
4. Disconnect the wire harness electrical connector from the neutral switch.
5. Check the continuity of the switch by connecting a multimeter (ohms setting) across the switch connector terminals.
6. With the ignition switch in the OFF position, slowly push the traction pedal in the forward and reverse direction while watching the multimeter. Continuity should be broken in both the forward and reverse directions.
7. Allow the traction pedal to return to the neutral position. There should be continuity across the terminals when the pedal is in neutral.
8. Connect the electrical connector to the switch.
9. Install center shroud to machine (Fig. 17).

Adjustment (Fig. 16)

1. Before adjusting the traction neutral switch, check and adjust traction system neutral position (see Operator's Manual).

IMPORTANT: To prevent traction neutral switch damage, make sure that end of cap screw does not contact switch.

2. Loosen jam nut on cap screw.
3. With traction pedal in the neutral position, rotate cap screw so the clearance between head of the screw and neutral switch is .030" to .090" (.8 to 2.2 mm).
4. Tighten jam nut on cap screw to secure adjustment. After jam nut is tightened, make sure that clearance between cap screw and neutral switch has not changed.
5. Check for proper switch operation (see Testing above).

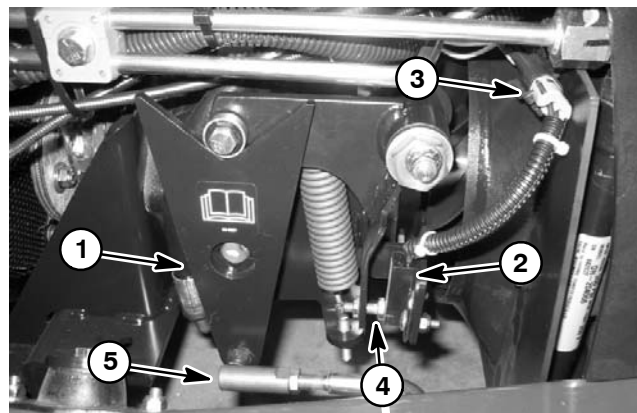

Figure 16

- | | |
|----------------------------|-----------------|
| 1. Traction pump lever | 4. Cap screw |
| 2. Traction neutral switch | 5. Traction rod |
| 3. Switch connector | |

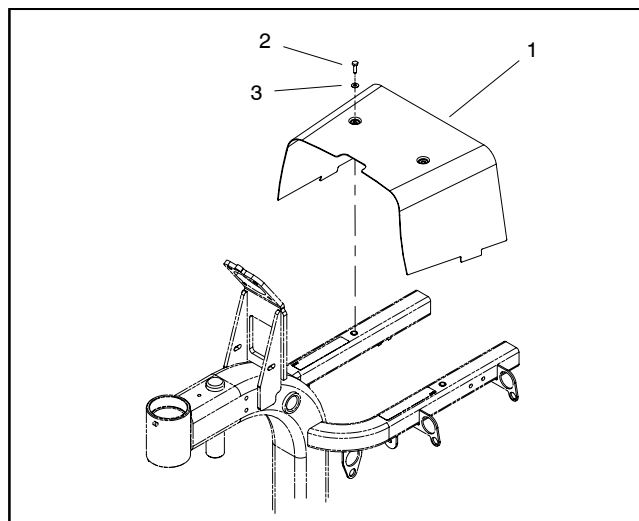

Figure 17

- | | |
|-----------------------|-------------------------|
| 1. Center shroud | 3. Flat washer (2 used) |
| 2. Cap screw (2 used) | |

Service and Repairs

Battery Storage

If the machine will be stored for more than 30 days:

1. Remove the battery and charge it fully (see Battery Service).
2. Either store battery on a shelf or on the machine.
3. Leave cables disconnected if the battery is stored on the machine.

4. Store battery in a cool atmosphere to avoid quick deterioration of the battery charge.

5. To help prevent the battery from freezing, make sure it is fully charged before storing the battery/machine (see Battery Service).

Battery Care

1. Battery electrolyte level must be properly maintained. The top of the battery must be kept clean. If the machine is stored in a location where temperatures are extremely high, the battery will discharge more rapidly than if the machine is stored in a location where temperatures are cool.

3. Battery cables must be tight on battery terminals to provide good electrical contact.

**WARNING**

Wear safety goggles, a face shield and rubber gloves when working with electrolyte. Charge battery in a well ventilated place so gasses produced while charging can dissipate. Since the gases are explosive, keep open flames and electrical sparks away from the battery; do not smoke. Nausea may result if the gases are inhaled. Unplug battery charger from electrical outlet before connecting or disconnecting charger leads to or from battery terminals.

**WARNING**

Connecting cables to the wrong battery terminal could result in personal injury and/or damage to the electrical system.

IMPORTANT: Do not remove battery filler caps while cleaning battery.

2. Check battery condition weekly or after every 50 hours of operation. Keep terminals and entire battery case clean because a dirty battery will discharge slowly.

A. Clean battery by washing entire case with a solution of baking soda and water. Rinse with clear water.

B. Spray battery terminals with Battery Terminal Protector (Toro Part No. 107-0392) to prevent cable and terminal corrosion. Petroleum jelly can be used as well.

4. If corrosion occurs at battery terminals, disconnect cables from battery. Always disconnect negative (-) cable first and then positive (+) cable. Clean cable connectors and battery terminals separately. Reconnect cables with positive (+) cable first and then negative (-) cable. Coat battery posts and cable connectors with Battery Terminal Protector (Toro Part No. 107-0392) or petroleum jelly to prevent corrosion.

5. Check battery electrolyte level every 25 operating hours, and every 30 days if machine is in storage.

6. Maintain battery cell electrolyte level with distilled or demineralized water. Do not fill cells above the fill line.

Battery Service

The battery is the heart of the electrical system. With regular and proper service, battery life can be extended. Additionally, battery and electrical component failure can be prevented.

**CAUTION**

When working with batteries, use extreme caution to avoid splashing or spilling electrolyte. Electrolyte can destroy clothing and burn skin or eyes. Always wear safety goggles and a face shield when working with batteries.

Battery Specifications

BCI Group Size U1
300 CCA at 0° F (-18° C)
Reserve Capacity of 28 minutes at 80°F (27°C)

Dimensions (including terminal posts and handle)

Length 7.7 inches (19.6 cm)
Width 5.2 inches (13.2 cm)
Height 7.2 inches (18.3 cm)

Electrolyte Specific Gravity

Fully charged: 1.265 corrected to 80°F (27°C)
Discharged: less than 1.240

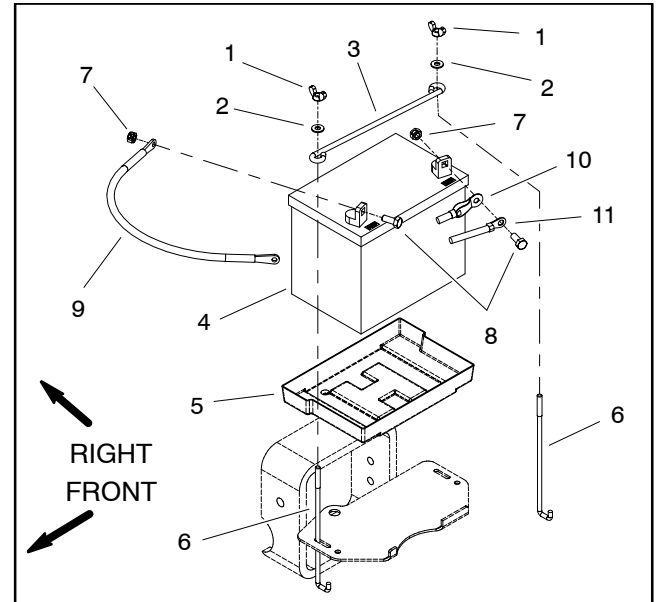

Figure 18

- | | |
|------------------|------------------------|
| 1. Wing nut | 7. Hex nut |
| 2. Flat washer | 8. Cap screw |
| 3. Hold down rod | 9. Positive (+) cable |
| 4. Battery | 10. Negative (-) cable |
| 5. Battery tray | 11. Harness ground |
| 6. Battery post | |

Removal and Installation (Fig. 18)

1. Park machine on a level surface, lower attachment, stop engine, apply parking brake and remove key from ignition switch.
2. Locate battery at rear of machine. Loosen and remove hex nut and cap screw that secure negative (-) cable to battery. Separate negative (-) cable from battery terminal. After negative cable is removed, loosen and remove positive (+) cable.
3. Remove wing nuts and washers that secure battery hold down rod. Slide hold down rod away from battery.
4. Carefully remove battery from machine.
5. Install battery in reverse order making sure to connect positive (+) cable to battery before connecting negative (-) cable.

NOTE: Before connecting the negative (ground) cable, connect a digital multimeter (set to amps) between the negative battery post and the negative (ground) cable connector. The reading should be less than 0.1 amp. If the reading is 0.1 amp or more, the machine's electrical system should be inspected for short circuits or faulty components and repaired.

Inspection and Maintenance

1. Check for cracks in battery case. Replace battery if cracked or leaking.
 2. Check battery terminals for corrosion. Use wire brush to clean corrosion from terminals.
- IMPORTANT: Before cleaning the battery, tape or block vent holes to the filler caps and make sure the caps are on tightly.**
3. Check for signs of wetness or leakage on the top of the battery which might indicate a loose or missing filler cap, overcharging, loose terminal post or overfilling. Also, check battery case for dirt and oil. Clean the battery with a solution of baking soda and water, then rinse it with clean water.
 4. Check that the cover seal is not broken away. Replace the battery if the seal is broken or leaking.
 5. Check the electrolyte level in each cell. If the level is below the tops of the plates in any cell, fill all cells with **distilled water** between the minimum and maximum fill lines. Charge at 15 to 25 amps for 15 minutes to allow sufficient mixing of the electrolyte.

Testing

1. To properly test a battery, perform a high-discharge test using an adjustable load tester. This is one of the most reliable means of testing a battery as it simulates the cold-cranking test. A commercial battery load tester is **required** to perform this test.



A. Check the voltage across the battery terminals prior to testing the battery. If the battery voltage is less than 12.4 VDC, charge the battery.

B. If the battery has recently been charged, remove the battery surface charge before performing the load test. Disconnect and ground the engine spark plug wires to prevent the engine from starting. Engage the starter motor for 10 seconds to remove battery surface charge. Reconnect the spark plug wires.

C. Make sure battery terminals are free of corrosion.

D. Measure the battery electrolyte temperature of the center cell.

E. Connect a battery load tester to the battery terminals **following the load tester manufacturer's instructions**. Connect a digital multimeter to the battery terminals.

F. Using the battery load tester, apply a test load of 150 amps (one half the CCA rating of the battery) for 15 seconds. Note the battery voltage reading at 15 seconds, then remove the load.

G. Using the table below, determine the minimum voltage for the electrolyte temperature reading:

Minimum Voltage	Battery Electrolyte Temperature	
	70°F (and up)	21°C (and up)
9.6	60°F	16°C
9.5	50°F	10°C
9.4	40°F	4°C
9.3	30°F	-1°C
9.1	20°F	-6°C
8.9	10°F	-12°C
8.7	0°F	-17°C

H. If the test voltage is below the minimum voltage, charge the battery and perform load test again. If test voltage still is below minimum voltage, replace the battery. If the test voltage is at or above the minimum voltage, return the battery to service.

2. If a battery load tester is not available, the battery can be tested by conducting a hydrometer test of the battery electrolyte.

IMPORTANT: Make sure the area around the cells is clean before opening the battery caps.

A. Measure the specific gravity of each cell with a hydrometer. Draw electrolyte in and out of the hydrometer barrel prior to taking a reading to warm-up the hydrometer. At the same time, take the temperature of the cell.

B. Temperature correct each cell reading. For each 10°F (5.5°C) above 80°F (26.7°C), add 0.004 to the specific gravity reading. For each 10°F (5.5°C) below 80°F (26.7°C), subtract 0.004 from the specific gravity reading.

Example: Cell Temperature	100°F
Cell Gravity	1.245
100°F minus 80°F equals 20°F (37.7°C minus 26.7°C equals 11.0°C)	
20°F multiply by 0.004/10°F equals 0.008 (11°C multiply by 0.004/5.5°C equals 0.008)	
ADD (conversion above)	<u>0.008</u>
Correction to 80°F (26.7°C)	1.253

C. If the difference between the highest and lowest cell specific gravity is 0.050 or greater or the lowest cell specific gravity is less than 1.225, charge the battery. Charge at the recommended rate and time given in **Charging** or until the specific gravity of all cells is 1.225 or greater with the difference in specific gravity between the highest and lowest cell less than 0.050. If these charging conditions can not be met, replace the battery.

Charging

To minimize possible damage to the battery and allow the battery to be fully charged, the slow charging method is presented here. This charging method can be accomplished with a constant current battery charger which is commonly available.



CAUTION

Follow the battery charger manufacturer's instructions when using a battery charger.

NOTE: Using specific gravity of the battery cells is the most accurate method of determining battery condition.

1. Determine the battery charge level from either its specific gravity or open circuit voltage.

Battery Charge Level	Specific Gravity	Open Circuit Voltage
100%	1.265	12.68
75%	1.225	12.45
50%	1.190	12.24
25%	1.155	12.06
0%	1.120	11.89

2. Determine the charging time and rate **using the battery charger manufacturer's instructions** or the following table.

NOTE: The reserve capacity of the battery used in Sand Pro and Infield Pro machines is 28 minutes.

Battery Reserve Capacity (Minutes)	Battery Charge Level (Percent of Fully Charged)			
	75%	50%	25%	0%
80 or less	3.8 hrs @ 3 amps	7.5 hrs @ 3 amps	11.3 hrs @ 3 amps	15 hrs @ 3 amps
81 to 125	5.3 hrs @ 4 amps	10.5 hrs @ 4 amps	15.8 hrs @ 4 amps	21 hrs @ 4 amps
126 to 170	5.5 hrs @ 5 amps	11 hrs @ 5 amps	16.5 hrs @ 5 amps	22 hrs @ 5 amps
171 to 250	5.8 hrs @ 6 amps	11.5 hrs @ 6 amps	17.3 hrs @ 6 amps	23 hrs @ 6 amps
above 250	6 hrs @ 10 amps	12 hrs @ 10 amps	18 hrs @ 10 amps	24 hrs @ 10 amps



CAUTION

Do not charge a frozen battery because it can explode and cause injury. Let the battery warm to 60°F (15.5° C) before connecting to a charger.

Charge the battery in a well-ventilated place to dissipate gases produced from charging. These gases are explosive; keep open flame and electrical spark away from the battery. Do not smoke. Nausea may result if the gases are inhaled. Unplug the charger from the electrical outlet before connecting or disconnecting the charger leads from the battery posts.

3. **Following the battery charger manufacturer's instructions**, connect the charger cables to the battery terminals. Make sure a good connection is made.

4. Charge the battery **following the battery charger manufacturer's instructions**.

5. Occasionally check the temperature of the battery electrolyte. If the temperature exceeds 125°F (51.6°C) or the electrolyte is violently gassing or spewing, the charging rate must be lowered or temporarily stopped.

6. Three hours prior to the end of battery charging, measure the specific gravity of a battery cell once per hour. The battery is fully charged when the cells are gassing freely at a low charging rate and there is less than a 0.003 change in specific gravity for three consecutive readings.

This page is intentionally blank.



Table of Contents

SPECIFICATIONS 2
SPECIAL TOOLS 3
SERVICE AND REPAIRS 4
 Front Wheel 4
 Rear Wheel 8
 Console 10
 Parking Brake 12
 Parking Brake Cable 14
 Hitch Assembly 16
 Steering Box (Sand Pro 3040 and Infield
 Pro 3040) 18
 Steering Box Service (Sand Pro 3040 and
 Infield Pro 3040) 20
 Front Castor Fork (Sand Pro 3040 and
 Infield Pro 3040) 22
 Front Castor Fork (Sand Pro 5040 and
 Infield Pro 5040) 24
 Operator Seat 26

Specifications

Item	Description
Tire Pressure Front Tire Rear Tire	4 to 6 PSI (0.3 to 0.4 Bar) 4 to 6 PSI (0.3 to 0.4 Bar)

Special Tools

Wheel Hub Puller

Part Number: **TOR4097**

The wheel hub puller allows safe removal of the wheel hub from the shaft of wheel motors.



Figure 1

Service and Repairs

Front Wheel

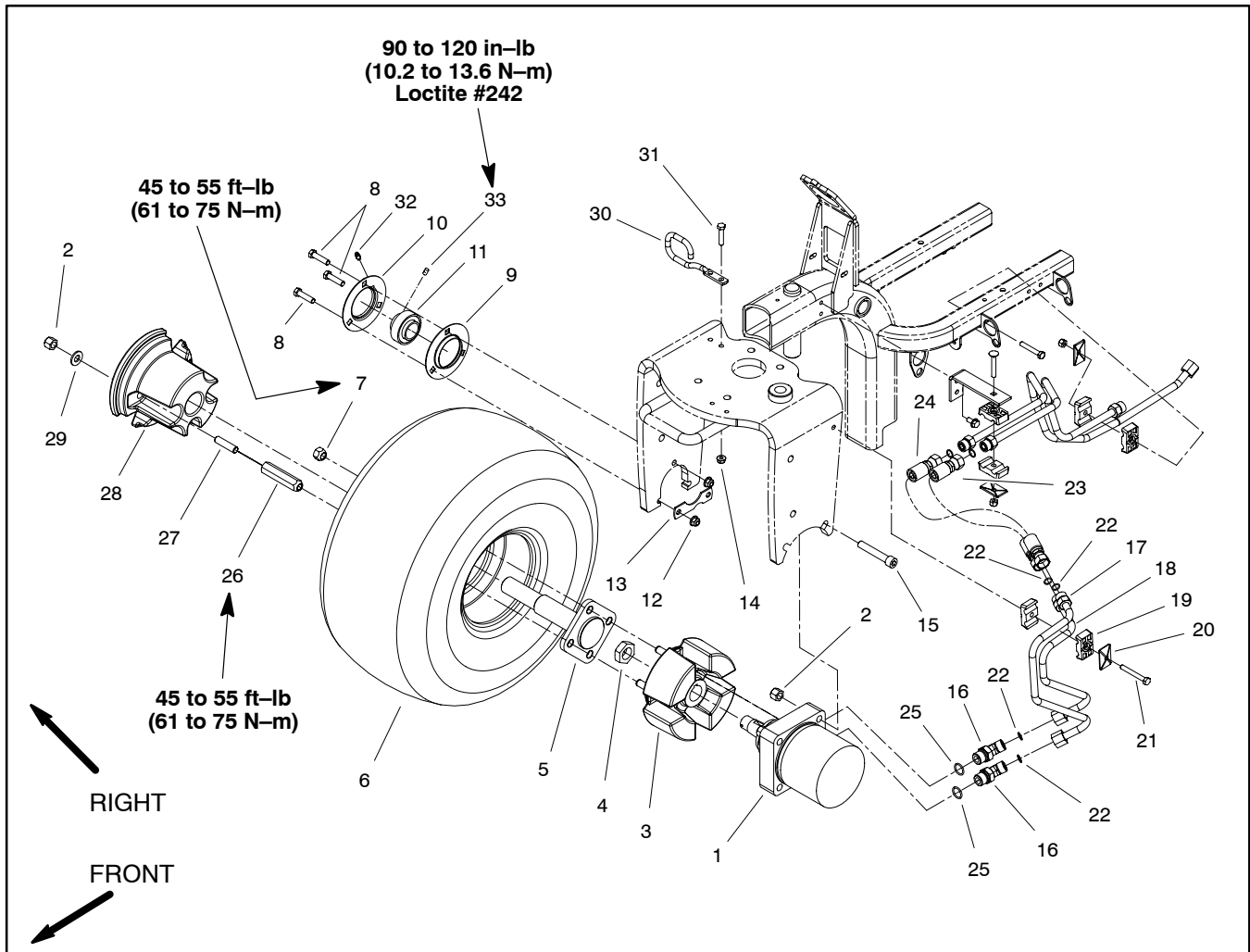

Figure 2

- | | | |
|----------------|--------------------------------|---------------------------------------|
| 1. Wheel motor | 12. Flange nut (3 used) | 23. Hydraulic hose |
| 2. Lock nut | 13. Bearing tab | 24. Hydraulic hose |
| 3. Wheel hub | 14. Flange nut (2 used) | 25. O-ring |
| 4. Lock nut | 15. Socket head screw (2 used) | 26. Wheel weight adapter (SP/IP 3040) |
| 5. Spindle | 16. Hydraulic fitting | 27. Wheel weight stud (SP/IP 3040) |
| 6. Front wheel | 17. Hydraulic tube | 28. Wheel weight (SP/IP 3040) |
| 7. Lug nut | 18. Hydraulic tube | 29. Thrust washer (SP/IP 3040) |
| 8. Cap screw | 19. Tube clamp | 30. Hose guide |
| 9. Flangette | 20. Cover plate | 31. Cap screw (2 used) |
| 10. Flangette | 21. Cap screw | 32. Grease fitting |
| 11. Bearing | 22. O-ring | 33. Set screw |

Removal (Fig. 2)

1. Park machine on a level surface, lower attachment, stop engine, apply parking brake and remove key from ignition switch. Chock rear wheels to prevent machine from moving during front wheel removal.

2. Loosen set screw on the bearing locking collar.

3. Support front of the machine. Remove three cap screws and lock nuts securing the flangettes and bearing tab to the castor fork.

4. Remove cap screw, cover plate and lock nut that secure hydraulic tube clamps to castor fork.

- Remove both socket head screws and lock nuts securing the hydraulic motor to the fork.

IMPORTANT: Support wheel and wheel motor when jacking up the front of the machine to prevent hydraulic tube damage.

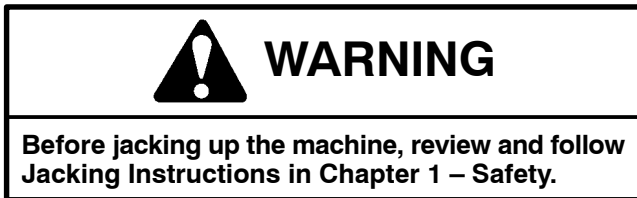

- Jack up front of machine slowly until the hydraulic motor and flanges can be removed from the fork. Remove flanges, spindle, wheel and motor from the fork.
- Slide flanges and bearing assembly from the spindle. Separate flanges from the bearing.
- For Sand Pro 5040 and Infield Pro 5040 machines, remove front wheel as follows:
 - Remove four (4) lug nuts from the drive studs.
 - Remove wheel from the drive studs and spindle.
- For Sand Pro 3040 and Infield Pro 3040 machines, remove front wheel as follows:

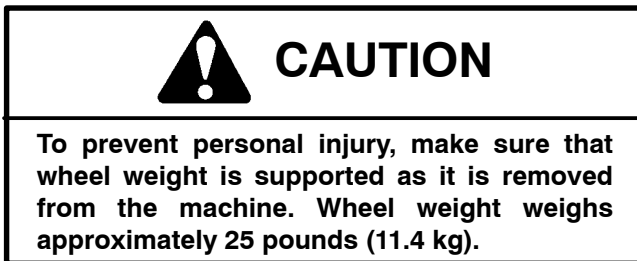

- Remove two (2) lock nuts and thrust washers that secure wheel weight to wheel.
 - Carefully slide wheel weight from weight studs.
 - Loosen and remove two (2) lug nuts and two (2) wheel weight adapters with studs.
 - Pull wheel from machine.
- Separate spindle from drive studs and wheel hub.
 - Secure hydraulic motor and hub to the machine to prevent damaging the hydraulic lines.
 - If wheel motor or hub removal is necessary, see Front Wheel Motor Removal in the Service and Repairs section of Chapter 4 – Hydraulic System.

Installation (Fig. 2)

- If wheel motor or hub was removed, install hub and motor (see Front Wheel Motor Installation in the Service and Repairs section of Chapter 4 – Hydraulic System).
- Position hydraulic motor and hub to the front fork.
- Install spindle to drive studs and wheel hub. Insert spindle and drive studs through wheel. Make sure valve stem and hydraulic motor are on opposite sides of the wheel.
- For Sand Pro 5040 and Infield Pro 5040 machines, secure front wheel as follows:
 - Install four (4) lug nuts onto drive studs.
 - Torque lug nuts evenly in a crossing pattern from 45 to 55 ft-lb (61 to 75 N-m).
- For Sand Pro 3040 and Infield Pro 3040 machines, secure front wheel as follows:
 - If studs were removed from wheel weight adapters, thread studs fully into the correct end of the adapter (Fig. 3).
 - Install two (2) lug nuts and two (2) wheel weight adapters with studs onto drive studs.
 - Torque lug nuts and wheel weight adapters evenly in a crossing pattern from 45 to 55 ft-lb (61 to 75 N-m).

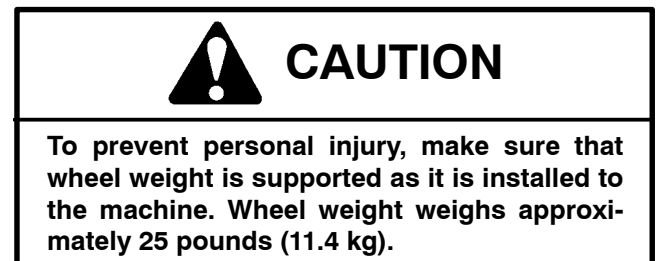

- Carefully slide wheel weight onto weight studs.
- Secure wheel weight to wheel with two (2) thrust washers and lock nuts.

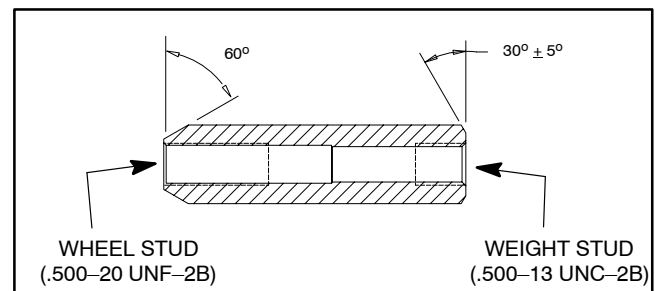

Figure 3

6. Slide flangette and bearing assembly onto the spindle shaft so the bearing locking collar faces the wheel.

7. Position hydraulic motor, wheel and flangettes to the front fork.

IMPORTANT: When securing wheel motor and flangettes to fork, tighten wheel motor fasteners before tightening flangette fasteners.

8. Carefully lower machine to align wheel motor and flangettes to fork. Make sure flangettes and wheel motor fit snugly to the fork.

A. Secure hydraulic motor to the front fork with two (2) socket head screws and lock nuts.

B. Secure flangettes to the fork with cap screws, bearing tab and lock nuts.

9. Lower machine completely to the ground. Make sure flangettes and hydraulic motor are positioned correctly into the fork. Tighten fasteners to secure wheel to front fork.

10. Apply Loctite #242 (or equivalent) to bearing locking collar set screw. Install set screw to locking collar and torque from 90 to 120 in-lb (10.2 to 13.6 N-m).

11. Position hydraulic tube clamps to tubes and castor fork. Secure clamps with cap screws, cover plates and lock nuts.

This page is intentionally blank.

Rear Wheel

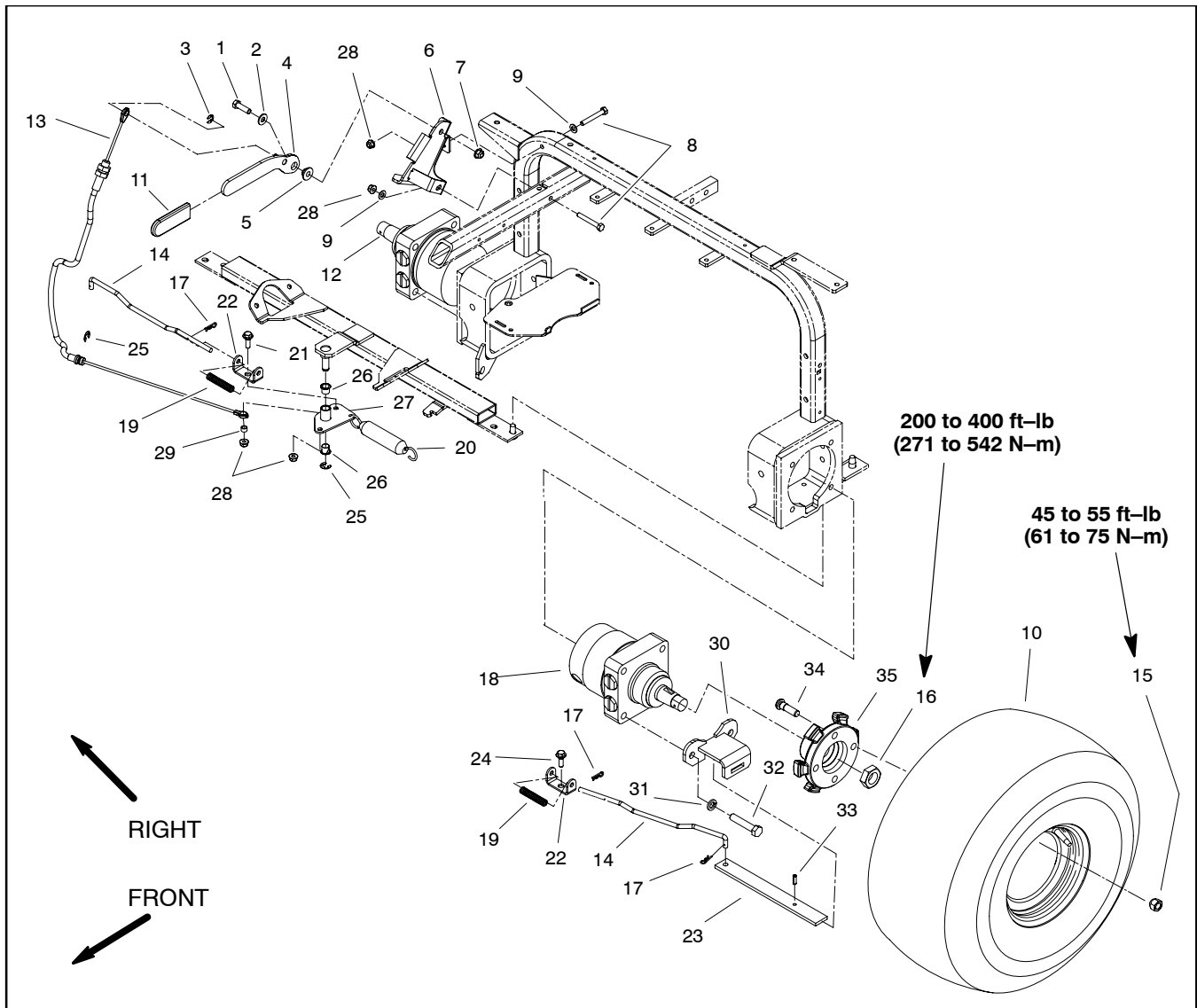
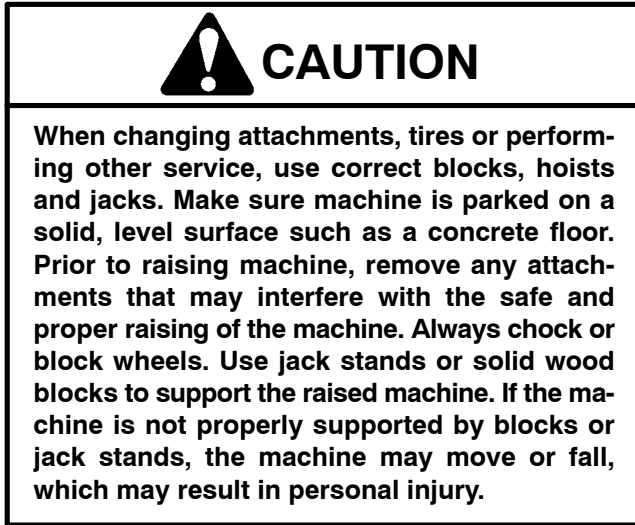

Figure 4

- | | | |
|-----------------------------|--------------------------------|------------------------------------|
| 1. Cap screw | 13. Brake cable | 25. Retaining ring |
| 2. Flat washer | 14. Brake rod | 26. Bushing |
| 3. Retaining ring | 15. Lug nut (4 used per wheel) | 27. Bellcrank |
| 4. Brake lever | 16. Lock nut | 28. Flange nut |
| 5. Pivot bushing | 17. Hair pin | 29. Spacer |
| 6. Brake lever bracket | 18. LH wheel motor | 30. Brake bracket (2 used) |
| 7. Flange nut | 19. Compression spring | 31. Lock washer (4 used per motor) |
| 8. Cap screw | 20. Extension spring | 32. Cap screw (4 used per motor) |
| 9. Flat washer | 21. Shoulder bolt | 33. Roll pin (2 used) |
| 10. Wheel and tire assembly | 22. Parking latch clevis | 34. Drive stud (4 used per wheel) |
| 11. Grip | 23. Brake bar (2 used) | 35. Wheel hub (2 used) |
| 12. RH wheel motor | 24. Shoulder bolt | |

Removal (Fig. 4)

1. Park machine on a level surface, lower attachment, stop engine, apply parking brake and remove key from ignition switch.



2. Chock front wheel to prevent machine from shifting. Using a jack or hoist, raise machine so rear wheel is off ground. Support machine with jack stands or wooden blocking (see Jacking Instructions in Chapter 1 – Safety).
3. Remove four (4) lug nuts and remove rear wheel.

Installation (Fig. 4)

1. Install rear wheel and secure with four (4) lug nuts.
2. Lower machine to ground.
3. Torque lug nuts evenly in a crossing pattern from 45 to 55 ft–lb (61 to 75 N–m).

Console

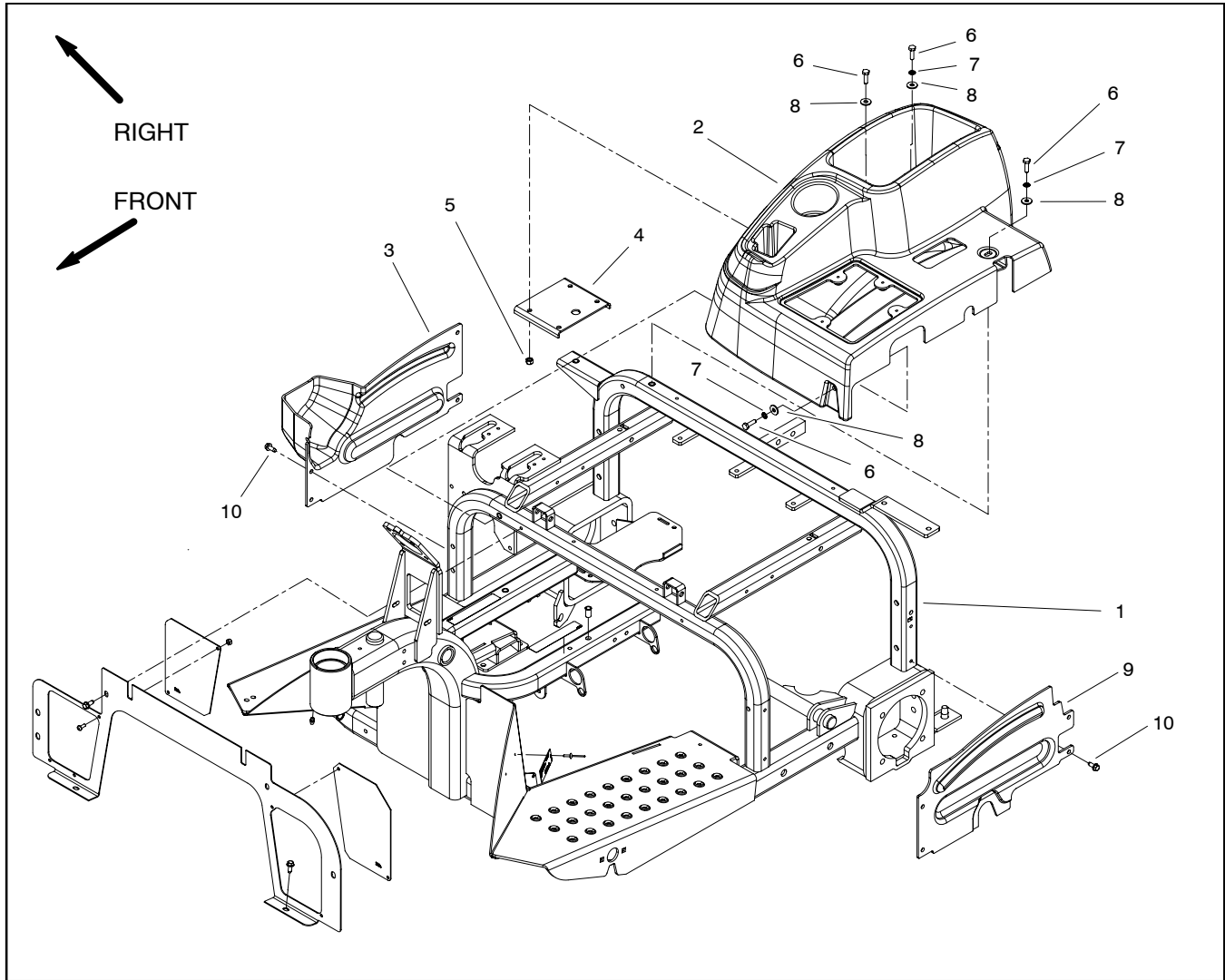

Figure 5

- | | | |
|--------------------------|-------------------------|--------------------------------|
| 1. Frame | 5. Lock nut (4 used) | 8. Flat washer (6 used) |
| 2. Console | 6. Cap screw (6 used) | 9. LH wheel shroud |
| 3. RH wheel shroud | 7. Lock washer (3 used) | 10. Washer head screw (8 used) |
| 4. Console support plate | | |

Removal (Fig. 5)

1. Park machine on a level surface, lower attachment, stop engine, apply parking brake and remove key from ignition switch.

2. Remove knob from lift lever.

3. Remove four (4) screws and flat washers that secure control panel to console (Fig. 6). Lift control panel, unplug wire harness connector from hour meter and remove control panel from machine.

NOTE: Console support plate (item 4) is fastened to console.

4. Remove three (3) cap screws, lock washers and flat washers that secure console to frame.

5. Lift console from machine.

Installation (Fig. 5)

1. Position console to machine.

2. Secure console to machine with removed fasteners.

3. Connect wire harness connector to hour meter and position control panel to console. Secure control panel with four (4) screws and flat washers (Fig. 6).

4. Install knob to lift lever.

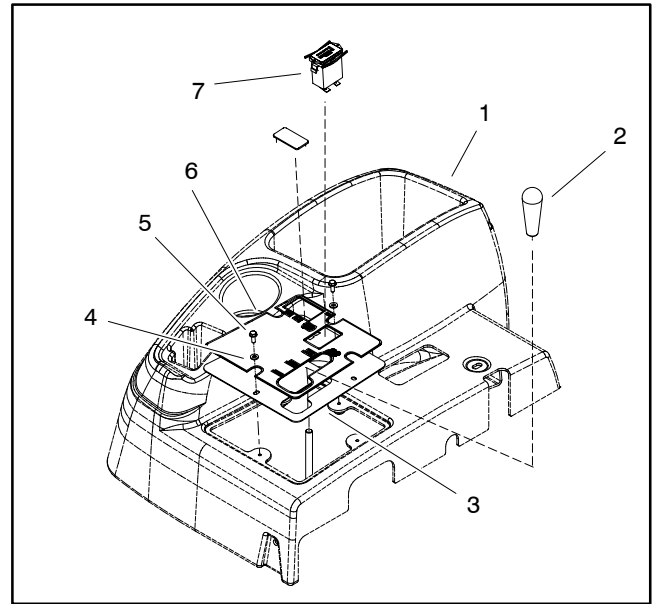

Figure 6

- | | |
|-------------------------|-------------------|
| 1. Console | 5. Screw (4 used) |
| 2. Lift lever knob | 6. Panel decal |
| 3. Control panel | 7. Hour meter |
| 4. Flat washer (4 used) | |

Parking Brake

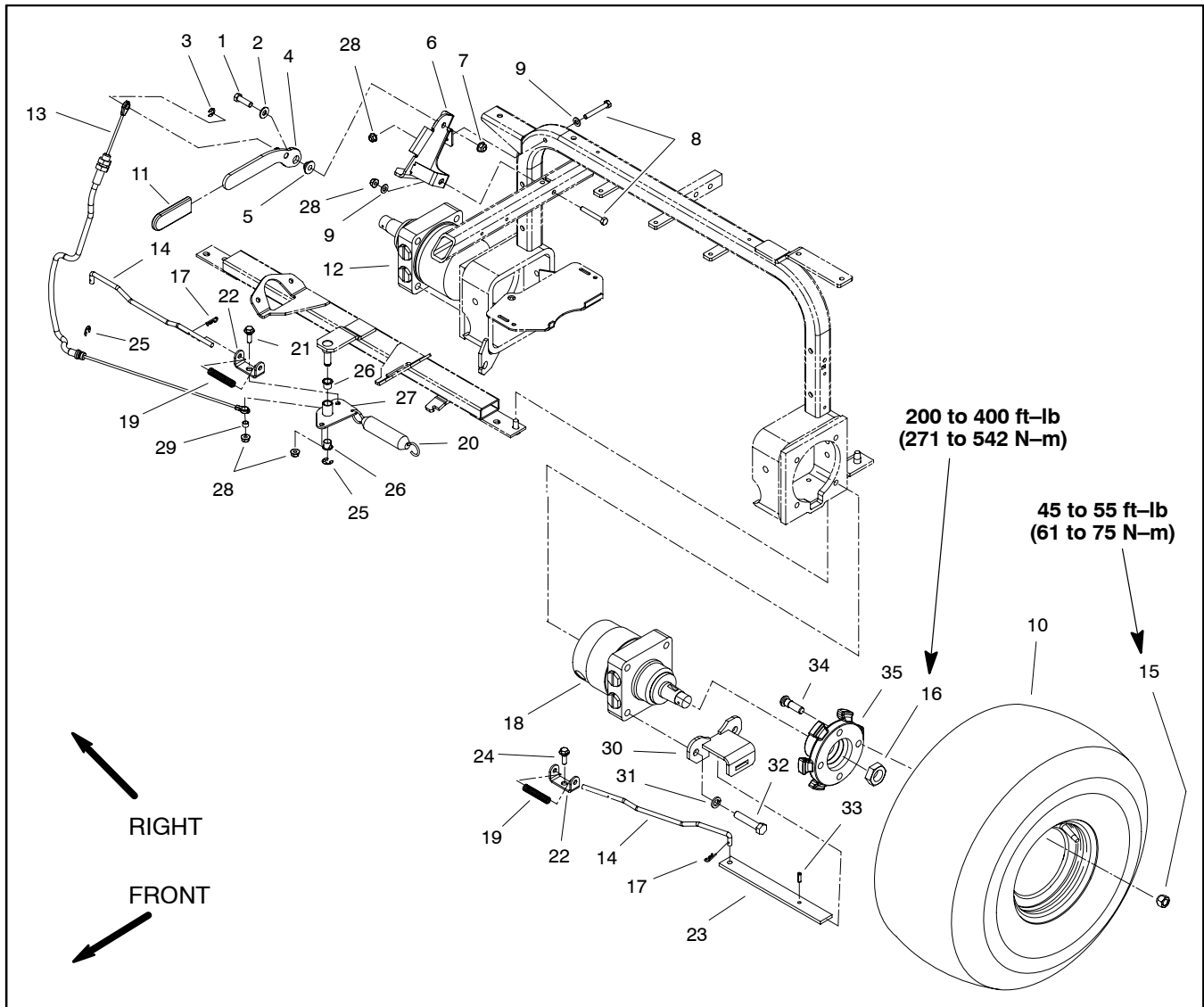

Figure 7

- | | | |
|-----------------------------|--------------------------------|------------------------------------|
| 1. Cap screw | 13. Brake cable | 25. Retaining ring |
| 2. Flat washer | 14. Brake rod | 26. Bushing |
| 3. Retaining ring | 15. Lug nut (4 used per wheel) | 27. Bellcrank |
| 4. Brake lever | 16. Lock nut | 28. Flange nut |
| 5. Pivot bushing | 17. Hair pin | 29. Spacer |
| 6. Brake lever bracket | 18. LH wheel motor | 30. Brake bracket (2 used) |
| 7. Flange nut | 19. Compression spring | 31. Lock washer (4 used per motor) |
| 8. Cap screw | 20. Extension spring | 32. Cap screw (4 used per motor) |
| 9. Flat washer | 21. Shoulder bolt | 33. Roll pin (2 used) |
| 10. Wheel and tire assembly | 22. Parking latch clevis | 34. Drive stud (4 used per wheel) |
| 11. Grip | 23. Brake bar (2 used) | 35. Wheel hub (2 used) |
| 12. RH wheel motor | 24. Shoulder bolt | |

Removal (Fig. 7)

1. Park machine on a level surface, lower attachment, stop engine and remove key from ignition switch.
2. Make sure parking brake is disengaged.
3. Block front wheel. Jack or hoist rear of machine from ground and support machine with blocking or jack stands (see Operator's Manual and Jacking Instructions in Chapter 1 – Safety).
4. Remove rear wheel assembly (see Rear Wheel Removal in this section).



5. Remove parking brake components as needed using Figure 7 as a guide.
6. Clean all parts. Inspect brake bar and brake lugs on wheel hub for excessive wear or damage. Replace any damaged parts.
7. If wheel hub requires removal:
 - A. Loosen, but do not remove, lock nut that secures wheel hub to wheel motor shaft.

IMPORTANT: DO NOT hit wheel hub, wheel hub puller or wheel motor with a hammer during wheel hub removal or installation. Hammering may cause damage to the wheel motor.

 - B. Using hub puller (see Special Tools), loosen wheel hub from wheel motor. Remove hub puller.
 - C. Remove lock nut and wheel hub from motor shaft. Locate and retrieve woodruff key.

Installation (Fig. 7)



1. Install removed parking brake components using Figure 7 as a guide.
2. If wheel hub was removed:
 - A. Make sure that wheel motor shaft and wheel hub taper are thoroughly cleaned.
 - B. Position woodruff key into wheel motor shaft.
 - C. Install wheel hub assembly to wheel motor shaft and secure with nut. Torque nut from 200 to 400 ft–lb (271 to 542 N–m).
3. Install wheel assembly (see Rear Wheel Installation in this section).
4. Lower machine to ground.

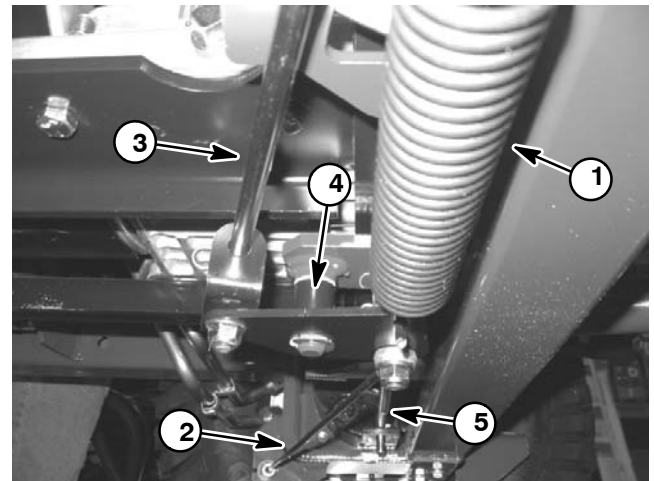

Figure 8

- | | |
|---------------------|-----------------|
| 1. Extension spring | 4. Bellcrank |
| 2. Brake cable | 5. RH brake rod |
| 3. LH brake rod | |

Parking Brake Cable

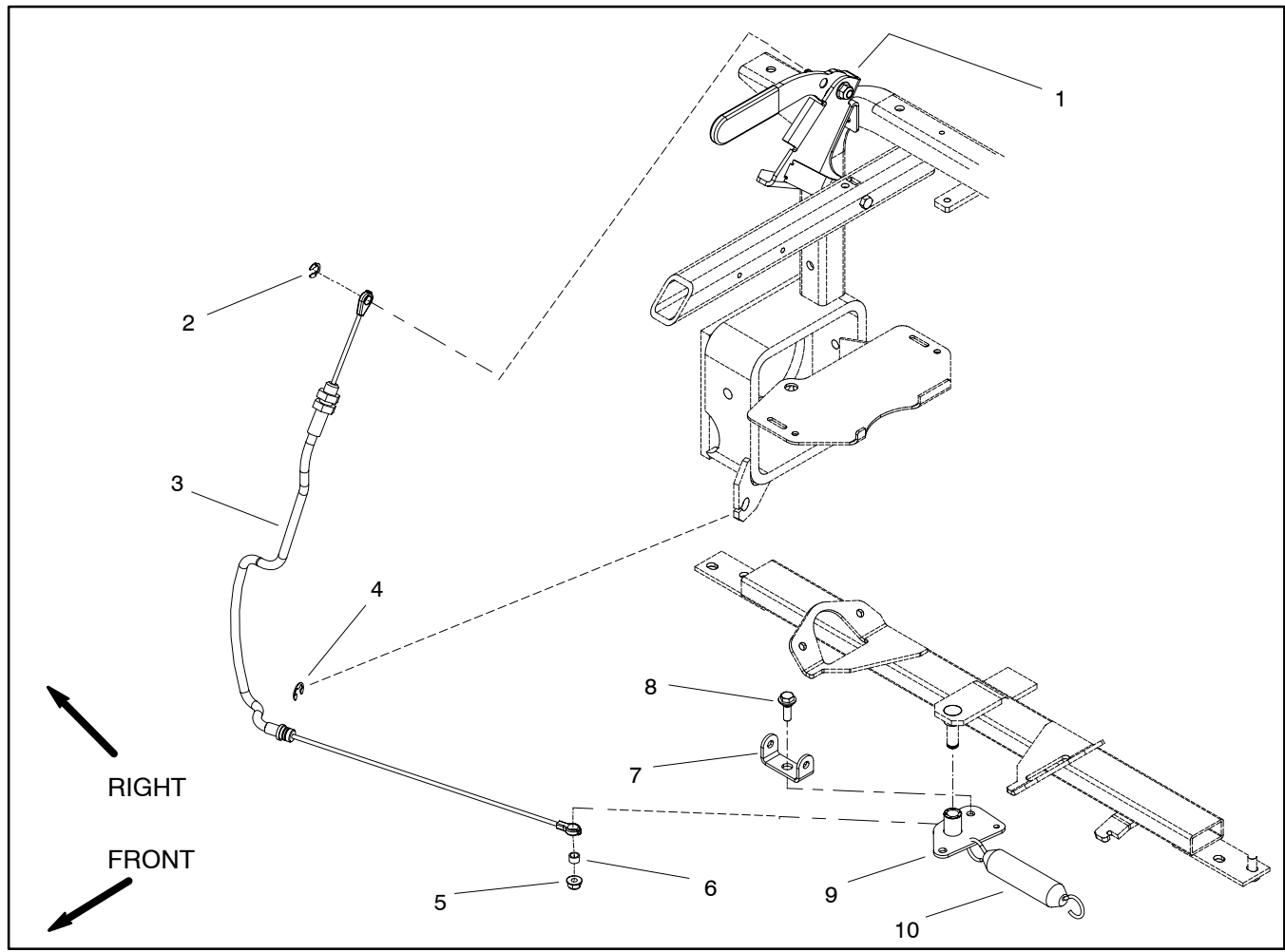

Figure 9

- | | | |
|-------------------|-----------------|----------------------|
| 1. Brake lever | 5. Flange nut | 8. Shoulder bolt |
| 2. Retaining ring | 6. Spacer | 9. Bellcrank |
| 3. Brake cable | 7. Brake clevis | 10. Extension spring |
| 4. Retaining ring | | |

Removal (Fig. 9)

1. Park machine on a level surface, lower attachment, stop engine and remove key from ignition switch.
2. Make sure parking brake is disengaged.
3. Remove console from machine (see Console Removal in this section).
4. Loosen jam nuts that secure parking brake cable to brake lever bracket.
5. Remove retaining ring that secures brake cable to brake lever. Slide brake cable from lever.
6. Remove brake cable from parking brake bellcrank on rear cross tube of frame:
 - A. Remove flange nut that secures parking brake cable end to parking brake bellcrank.
 - B. Slide brake cable end and spacer from shoulder bolt.
7. Note routing of parking brake cable. Remove brake cable from machine.

Installation (Fig. 9)

1. Position new parking brake cable to machine noting original routing.
2. Secure brake cable to parking brake bellcrank on rear cross tube of frame:
 - A. Slide spacer and brake cable end onto shoulder bolt.
 - B. Secure parking brake cable end to parking brake bellcrank with flange nut.
3. Position brake cable end to parking brake lever. Secure cable end to lever with retaining ring.
4. Secure brake cable to brake lever bracket with jam nuts.
5. Install console to machine (see Console Installation in this section).
6. Check parking brake operation.

Hitch Assembly

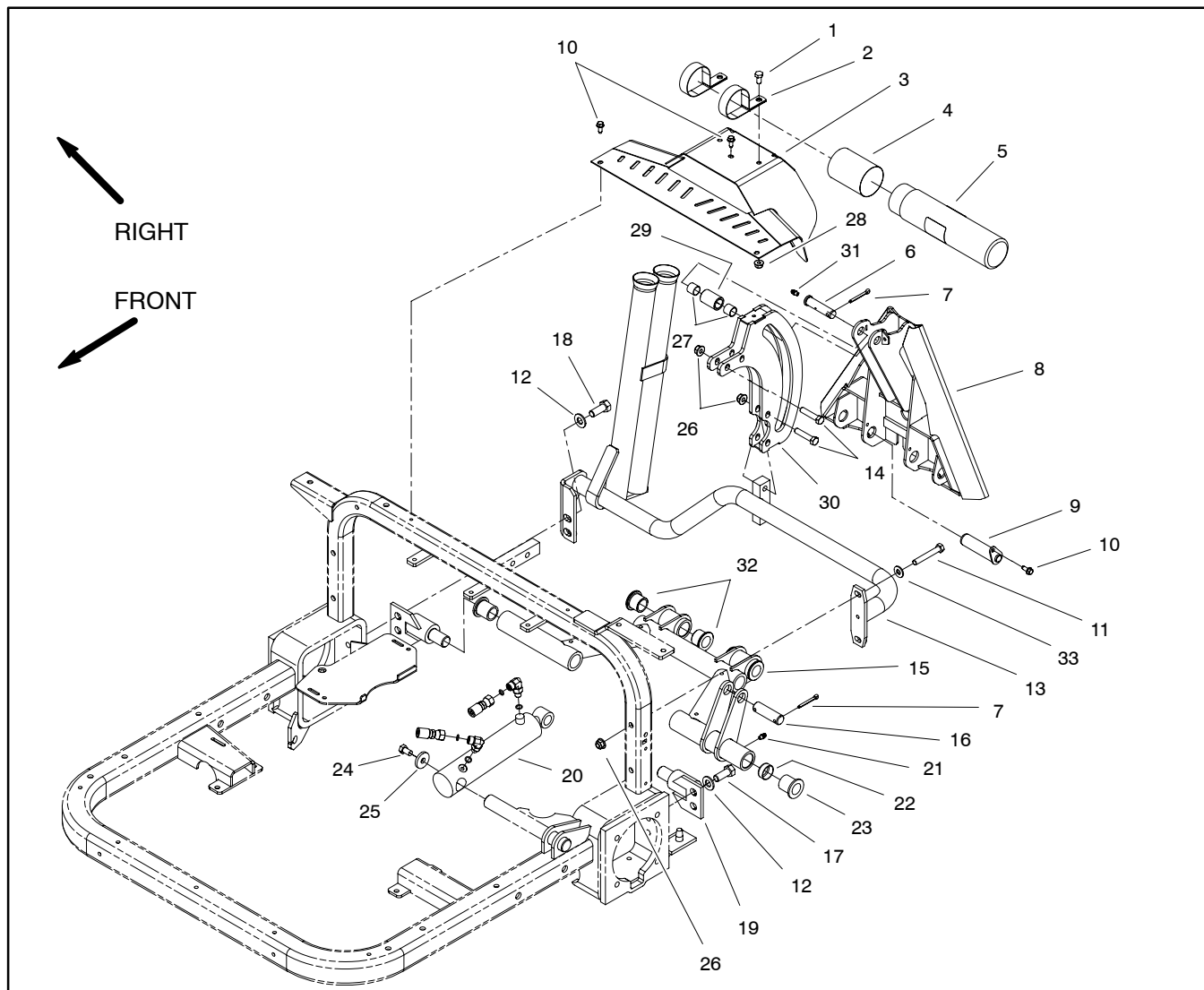

Figure 10

- | | | |
|------------------------|-----------------------------|-----------------------------|
| 1. Cap screw (2 used) | 12. Lock washer (4 used) | 23. Flange bushing (2 used) |
| 2. R-clamp (2 used) | 13. Hitch frame | 24. Cap screw |
| 3. Rear cover | 14. Cap screw (4 used) | 25. Flat washer |
| 4. Housing cap | 15. Hitch tube | 26. Flange nut |
| 5. Manual housing | 16. Cylinder pin | 27. Bushing |
| 6. Clevis pin | 17. Cap screw (2 used) | 28. Flange nut (2 used) |
| 7. Cotter pin | 18. Cap screw (2 used) | 29. Roller tube |
| 8. Hitch adapter | 19. Pivot pin (2 used) | 30. Roller plate |
| 9. Pin (2 used) | 20. Lift cylinder | 31. Grease fitting |
| 10. Washer head screw | 21. Grease fitting (4 used) | 32. Flange bushing (4 used) |
| 11. Cap screw (2 used) | 22. Expansion plug (2 used) | 33. Flat washer (2 used) |

Removal (Fig 10)

1. Park machine on a level surface, lower attachment, stop engine, apply parking brake and remove key from ignition switch.

2. Remove attachment from machine.

3. Remove three (3) washer head screws that secure rear cover to machine. Remove rear cover.

4. Remove hitch adapter from machine:

A. Support hitch adapter to prevent it from falling during removal.

B. Remove two (2) washer head screws (item 10) that secure pins (item 9) to hitch adapter. Pull pins from hitch adapter and hitch tube.

C. Remove one (1) cotter pin from clevis pin (item 6) that secures top of hitch adapter to roller plate. Pull cotter pin from hitch adapter and roller plate.

D. Remove hitch adapter from machine.

5. If hitch tube is to be removed from machine, remove one (1) cotter pin from cylinder pin (item 16) that secures lift cylinder to hitch tube. Slide cylinder pin from hitch tube and lift cylinder.

6. Remove remaining hitch assembly components from machine as needed using Figure 10 as a guide.

7. If required, remove bushing(s) from hitch tube (Fig. 11) and/or roller tube.

Installation (Fig 10)

1. If expansion plug was removed from hitch tube, press plug into tube so outer edge of plug is 1.690" (42.9 mm) from outer surface of hitch tube (Fig. 11).

2. If bushings were removed from hitch tube and/or roller tube, install removed bushing(s).

3. Install all removed hitch assembly components using Figure 10 as a guide.

4. Lubricate hitch assembly grease fittings.

5. Install attachment to machine.

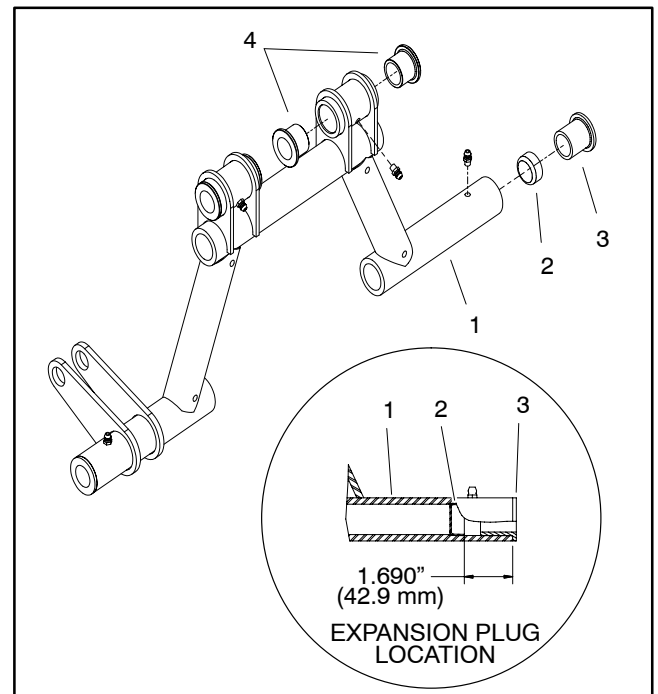

Figure 11

- | | |
|----------------------------|----------------------------|
| 1. Hitch tube | 3. Flange bushing (2 used) |
| 2. Expansion plug (2 used) | 4. Flange bushing (4 used) |

Steering Box (Sand Pro 3040 and Infield Pro 3040)

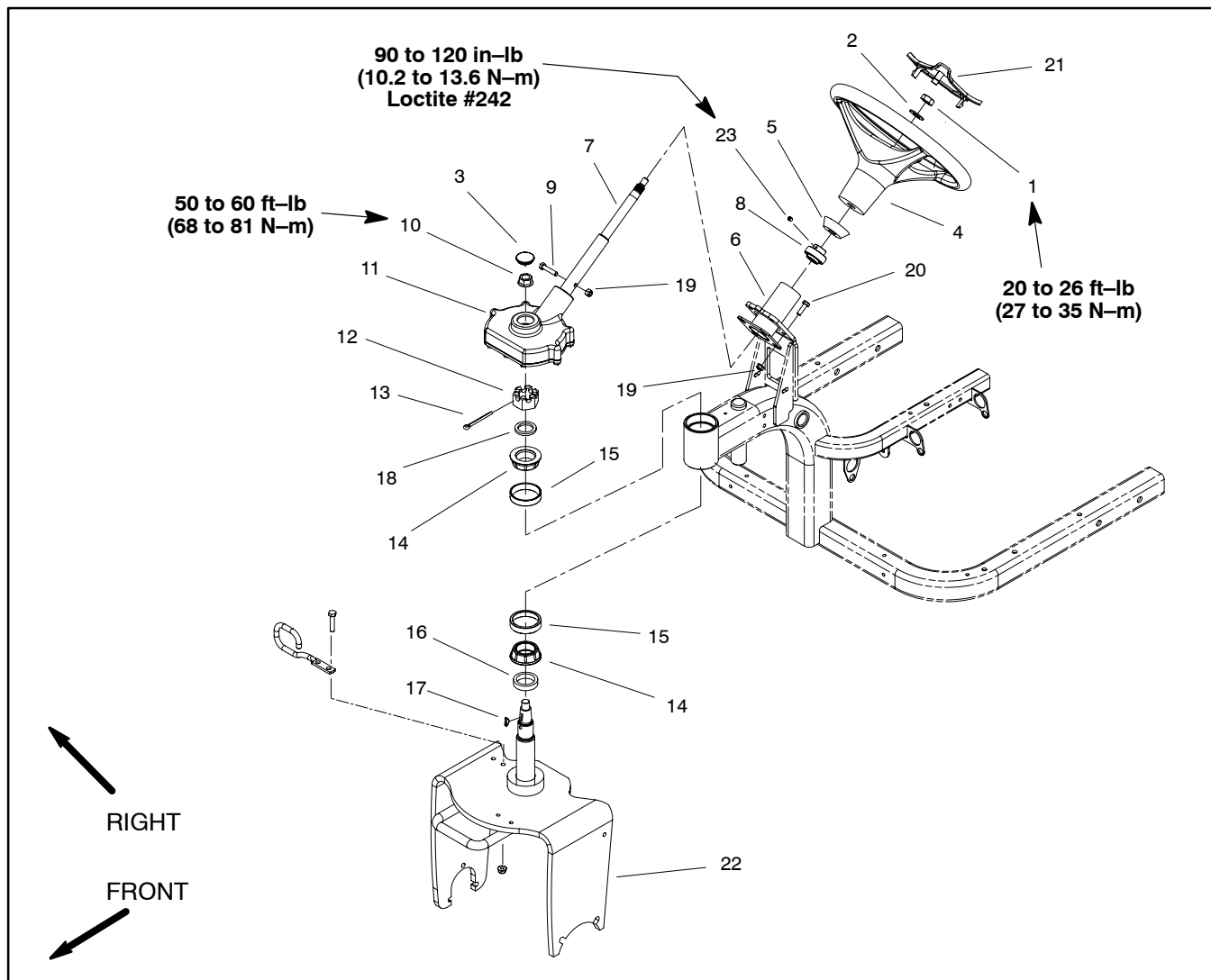

Figure 12

- | | | |
|----------------------------|---------------------|--------------------------|
| 1. Lock nut | 9. Cap screw | 17. Woodruff key |
| 2. Flat washer | 10. Flange nut | 18. Washer |
| 3. Grommet | 11. Steering box | 19. Lock nut |
| 4. Steering wheel | 12. Slotted hex nut | 20. Cap screw (4 used) |
| 5. Foam collar | 13. Cotter pin | 21. Steering wheel cover |
| 6. Steering tube | 14. Bearing cone | 22. Castor fork |
| 7. Steering shaft | 15. Bearing cup | 23. Set screw |
| 8. Bearing (extended race) | 16. Bearing spacer | |

Removal (Fig. 12)

1. Park machine on a level surface, lower attachment, stop engine, apply parking brake and remove key from ignition switch.
2. Remove fuel tank from machine (see Fuel Tank Removal in the Service and Repairs section of Chapter 3 – Engine).
3. Remove cap screw (item 9) and lock nut (item 19) that secure steering shaft to steering box.
4. Loosen set screw (item 23) that secures extended race of bearing (item 8) to steering shaft.
5. Lift on steering wheel to separate steering shaft from steering box input shaft. Position steering wheel and shaft assembly away from steering box.
6. Remove grommet (item 3) from top of steering box.
7. Loosen and remove flange nut (item 10) that secures steering box to castor fork shaft.

NOTE: The steering box sector gear and castor fork shaft have tapered shafts that must be loosened before steering box can be separated from castor fork.

8. Separate steering box from castor fork shaft using one of the following procedures:

A. Remove cotter pin (item 13) from castor fork shaft. Carefully loosen slotted hex nut (item 12) to push the steering box from castor fork shaft. Lift steering box from machine.

B. Remove eight (8) cap screws that secure steering plate to steering box cover (see Steering Box Service in this section). Lift cover from sector gear and position steering plate away from sector gear. Use a suitable puller to remove sector gear from castor fork shaft. Remove steering plate from machine.

9. Locate and retrieve woodruff key (item 17).

10. If slotted hex nut (item 12) was loosened during steering box removal, tighten the slotted hex nut from 15 to 20 in-lb (1.7 to 2.3 N-m). Make sure that the fork does not have any endplay and it rotates without binding. Secure slotted hex nut to castor fork with cotter pin (item 13).

Installation (Fig. 12)

1. If steering box was disassembled to separate steering box from castor fork shaft, assemble steering box (see Steering Box Service in this section).
2. Thoroughly clean tapered surfaces of castor fork shaft and sector gear in steering box.
3. Place woodruff key (item 17) in slot of castor fork shaft.
4. Align slot in steering box sector gear with woodruff key and slide steering box onto castor fork shaft.
5. Secure steering box to castor fork with flange nut (item 10). Torque flange nut from 50 to 60 ft-lb (68 to 81 N-m). Fit grommet (item 3) to top of steering box.
6. Apply antiseize lubricant to the steering box input shaft.
7. Position the front wheel straight ahead.
8. Slide steering shaft assembly onto steering box input shaft.
9. Secure steering shaft to steering box input shaft with cap screw and lock nut.
10. Apply Loctite #242 (or equivalent) to bearing set screw (item 23). Install and tighten set screw to secure extended race of bearing (item 8) to steering shaft. Torque set screw from 90 to 120 in-lb (10.2 to 13.6 N-m).
11. Install fuel tank to machine (see Fuel Tank Installation in the Service and Repairs section of Chapter 3 – Engine).

Steering Box Service (Sand Pro 3040 and Infield Pro 3040)

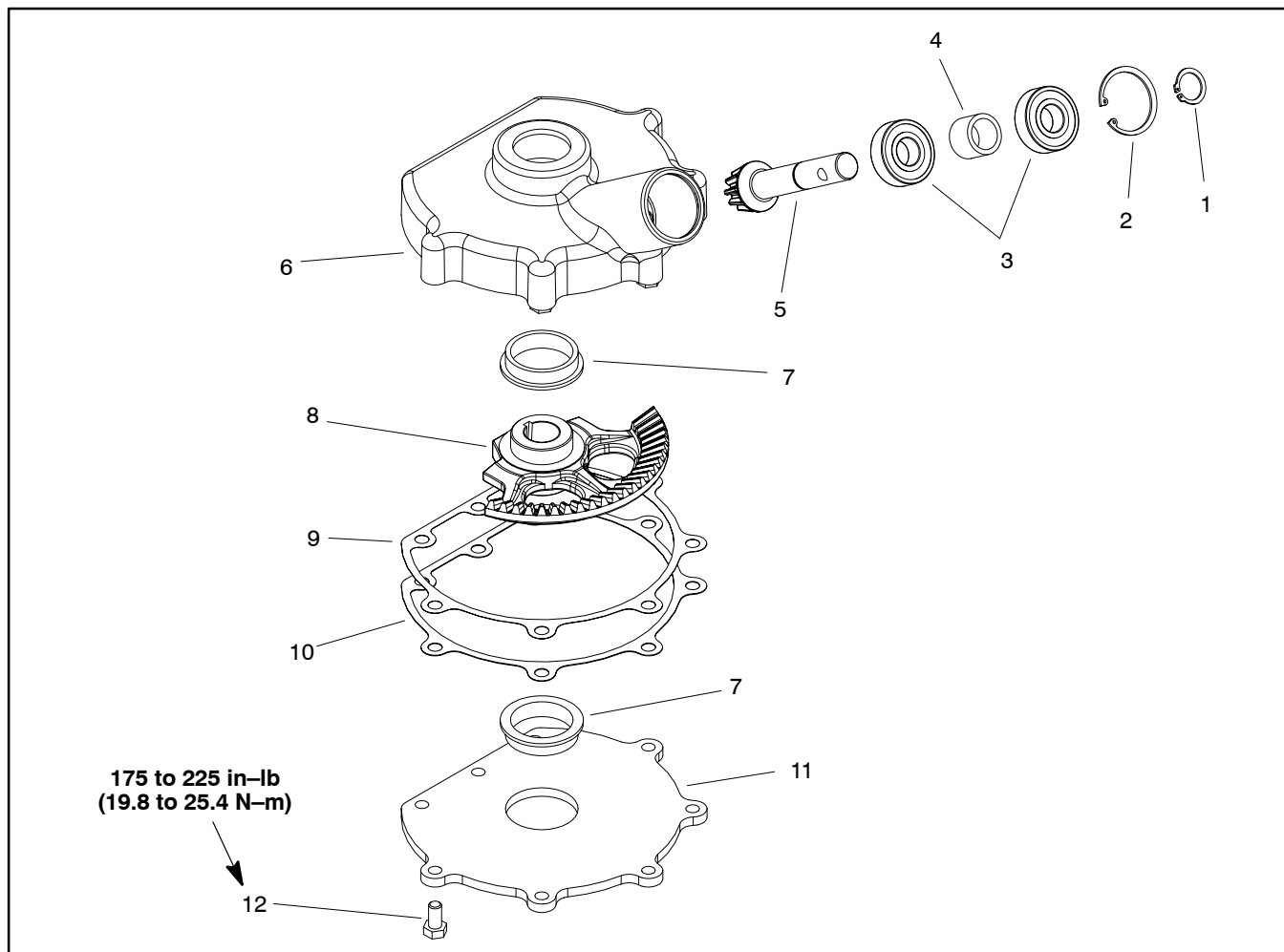

Figure 13

- | | | |
|-------------------|-------------------|------------------------|
| 1. Retaining ring | 5. Pinion gear | 9. Shim (as required) |
| 2. Retaining ring | 6. Steering cover | 10. Gasket |
| 3. Ball bearing | 7. Bushing | 11. Steering plate |
| 4. Spacer | 8. Sector gear | 12. Cap screw (8 used) |

Disassembly (Fig. 13)

1. Remove retaining ring that secures pinion gear assembly in steering cover. Pull pinion gear and bearings from steering box.
2. Remove eight (8) cap screws that secure steering plate to steering cover.
3. Remove steering plate, gasket, shim(s) and sector gear from steering cover.
4. If necessary, remove bearings from pinion gear:
 - A. Remove retaining ring from pinion gear shaft.
 - B. Press bearings and spacer tube from pinion gear shaft.
 - C. Discard removed bearings.
5. If necessary, remove bushings from steering cover and steering plate.
6. Thoroughly clean all steering box components. Inspect components for wear and/or damage.

Assembly (Fig. 13)

1. If removed, install bushings into steering cover and steering plate. Make sure that bushing flange is fully seated.

2. If bearings were removed from pinion gear shaft:
 - A. Press first bearing onto shaft by applying pressure equally to the inner and outer bearing race.
 - B. Slide spacer tube onto pinion shaft and then press second bearing onto shaft.
 - C. Install retaining ring to secure bearings to pinion gear.
3. Slide pinion gear assembly into steering cover.
4. Secure pinion gear in steering cover with retaining ring.
5. Install sector gear into steering cover making sure to align gear teeth of sector gear and pinion gear.
6. Fill steering housing with number 2 general purpose grease. Make sure all gear teeth on the sector and pinion gears are covered with grease.
7. Install shim(s), gasket and steering plate to steering cover.
8. Secure assembly with eight (8) cap screws. Torque screws in a crossing pattern from 175 to 225 in-lb (19.8 to 25.4 N-m).
9. After assembly of steering box, make sure that sector gear has minimal endplay. Also check that pinion shaft rotates freely. Maximum input torque to rotate pinion shaft must be less than 5 in-lb (.56 N-m). If necessary, add or remove shims to adjust endplay and input torque.

Front Castor Fork (Sand Pro 3040 and Infield Pro 3040)

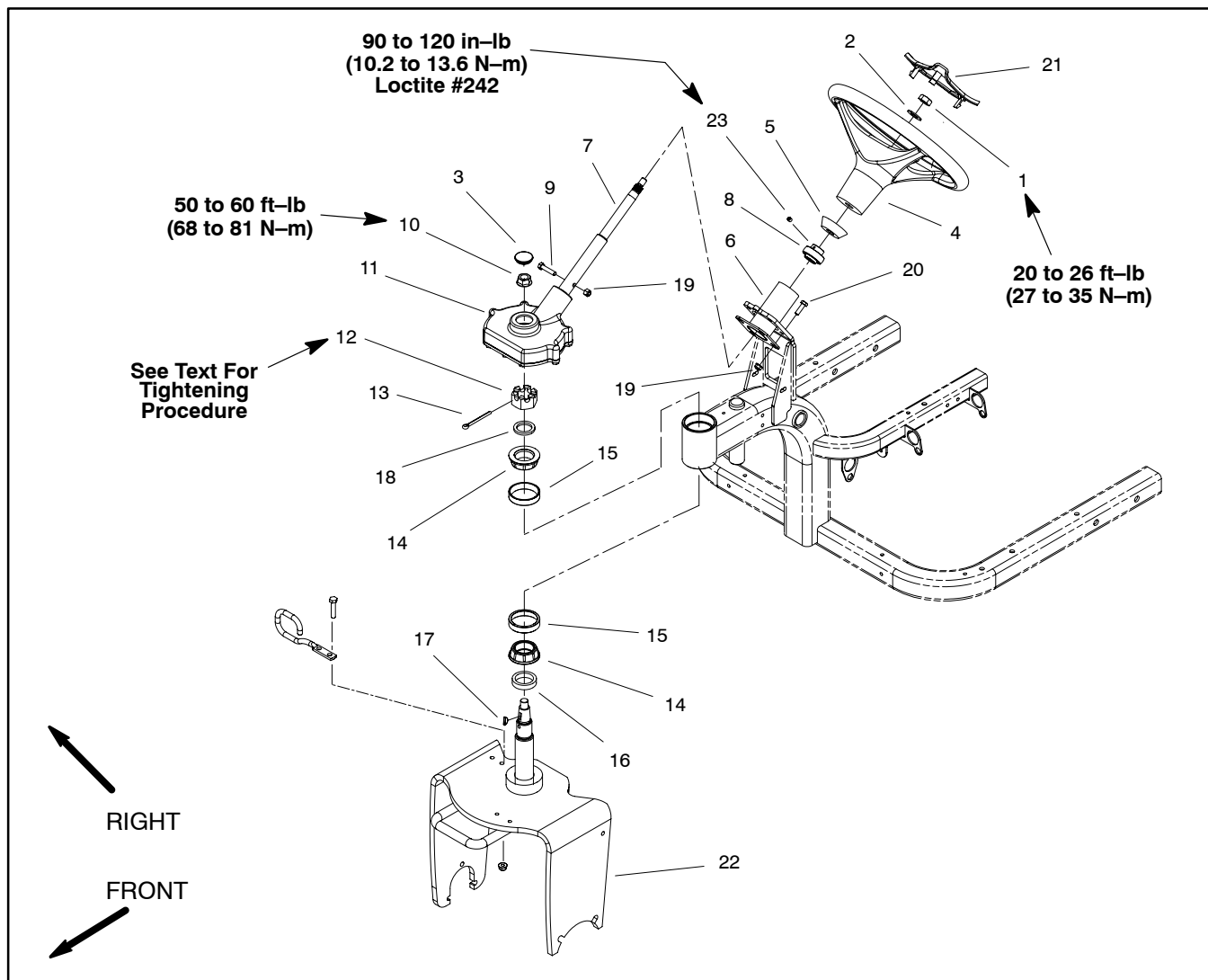

Figure 14

- | | | |
|----------------------------|---------------------|--------------------------|
| 1. Lock nut | 9. Cap screw | 17. Woodruff key |
| 2. Flat washer | 10. Flange nut | 18. Flat washer |
| 3. Grommet | 11. Steering box | 19. Lock nut |
| 4. Steering wheel | 12. Slotted hex nut | 20. Cap screw (4 used) |
| 5. Foam collar | 13. Cotter pin | 21. Steering wheel cover |
| 6. Steering tube | 14. Bearing cone | 22. Castor fork |
| 7. Steering shaft | 15. Bearing cup | 23. Set screw |
| 8. Bearing (extended race) | 16. Bearing spacer | |

Removal (Fig. 14)

1. Park machine on a level surface, lower attachment, stop engine, apply parking brake and remove key from ignition switch.
2. Remove fuel tank from machine (see Fuel Tank Removal in the Service and Repairs section of Chapter 3 – Engine).
3. Remove front wheel (see Front Wheel Removal in this section).
4. Remove hose guide from castor fork. Carefully position hydraulic hoses away from fork taking care to not damage hydraulic lines.
5. Remove steering box (see Steering Box Removal in this section).
6. Remove castor fork from machine:
 - A. Support castor fork to prevent it from falling.
 - B. Remove cotter pin and slotted hex nut that secure castor fork to frame.
 - C. Lower castor fork from machine.
 - D. Locate and retrieve flat washer (item 18).
7. Remove bearing cones and bearing spacer.
8. Clean and inspect bearing cups and cones. If wear or damage is identified, replace bearings.
9. If necessary, remove bearing cups from machine frame.

Installation (Fig. 14)

1. If bearing cups were removed from frame, press new bearing cups into frame making sure that cups are pressed fully to the shoulder in the frame.
2. Pack bearing cones with grease.
3. Slide bearing spacer onto castor fork shaft. Press lower bearing cone onto fork shaft.
4. Raise castor fork up through frame. Place upper bearing cone and flat washer on castor fork shaft. Thread slotted hex nut onto fork shaft but do not fully tighten.
5. Set the fork bearings by tightening the slotted hex nut from 75 to 100 in-lb (8.5 to 11.3 N–m) while rotating the castor fork by hand. Then, loosen the nut until the fork has endplay.
6. Next, tighten the slotted hex nut from 15 to 20 in-lb (1.7 to 2.3 N–m) while rotating the fork by hand. After final tightening, make sure that the fork does not have any endplay and it rotates without binding.
7. Secure slotted hex nut to castor fork with cotter pin.
8. Install steering box (see Steering Box Installation in this section).
9. Install front wheel (see Front Wheel Installation in this section).
10. Carefully position hydraulic hoses to fork and install hose guide.
11. Install fuel tank to machine (see Fuel Tank Installation in the Service and Repairs section of Chapter 3 – Engine).

Front Castor Fork (Sand Pro 5040 and Infield Pro 5040)

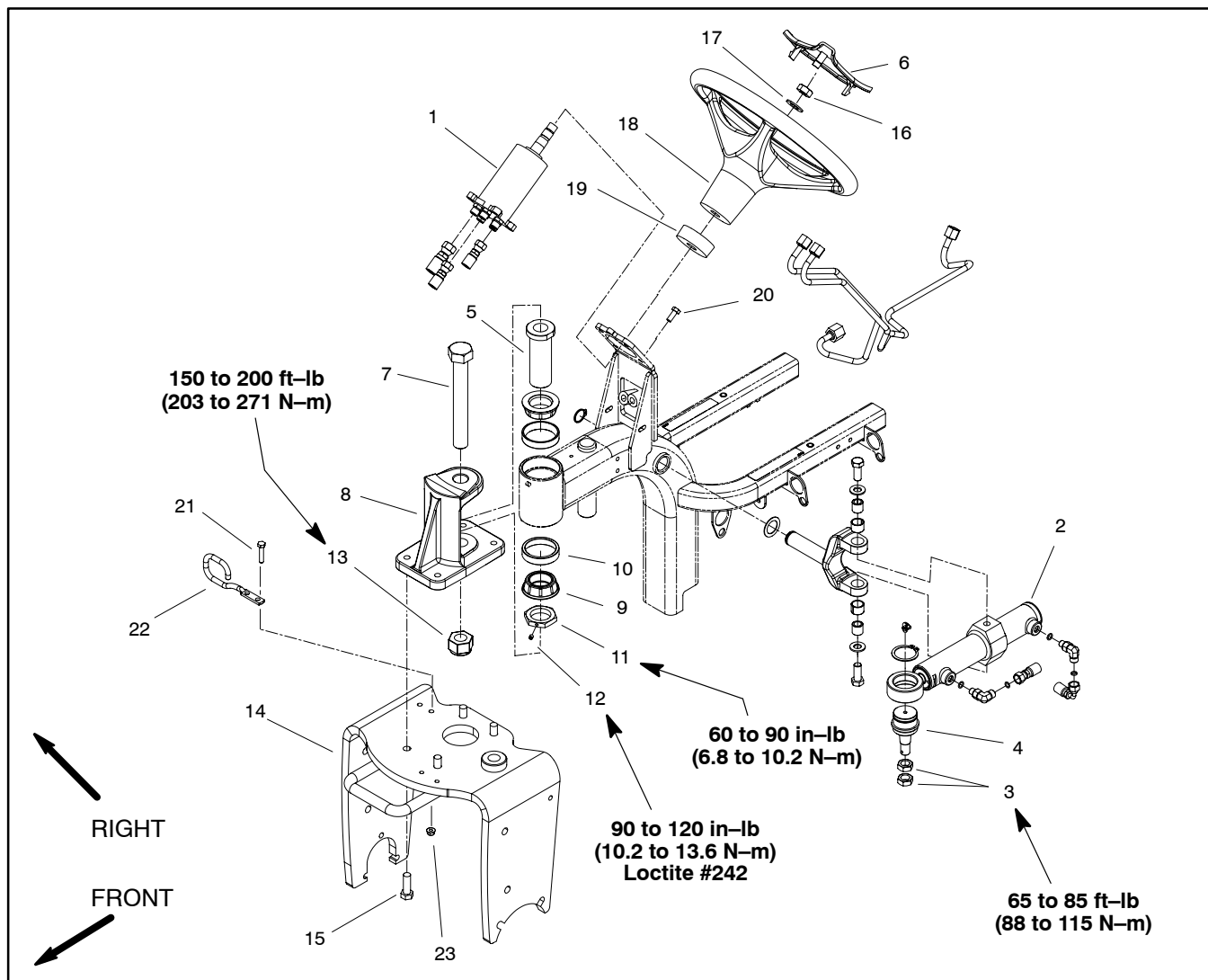

Figure 15

- 1. Steering control valve
- 2. Steering cylinder
- 3. Jam nut
- 4. Ball joint
- 5. Steering sleeve
- 6. Steering wheel cover
- 7. Cap screw
- 8. Steering pivot

- 9. Bearing cone (2 used)
- 10. Bearing cup (2 used)
- 11. Steering nut
- 12. Set screw
- 13. Lock nut
- 14. Castor fork
- 15. Cap screw (4 used)
- 16. Lock nut

- 17. Flat washer
- 18. Steering wheel
- 19. Foam collar
- 20. Cap screw (4 used)
- 21. Cap screw (2 used)
- 22. Hose guide
- 23. Flange nut (2 used)

Removal (Fig. 14)

1. Park machine on a level surface, lower attachment, stop engine, apply parking brake and remove key from ignition switch.
2. Remove fuel tank from machine (see Fuel Tank Removal in the Service and Repairs section of Chapter 3 – Engine).
3. Remove front wheel (see Front Wheel Removal in this section).
4. Remove hose guide from castor fork. Carefully position hydraulic hoses away from fork taking care to not damage hydraulic lines.
5. Remove two (2) jam nuts that secure steering cylinder ball joint to castor fork. Separate steering ball joint from castor fork.
6. Support castor fork to prevent it from falling
7. Remove four (4) cap screws (item 15) that secure castor fork to steering pivot. Remove castor fork from machine.
8. If necessary, remove steering pivot, steering sleeve and bearings from machine:
 - A. Remove lock nut (item 13) from cap screw (item 7) that retains steering pivot.
 - B. Slide cap screw from steering pivot and remove steering pivot from frame.
 - C. Loosen set screw in steering nut.
 - D. Remove steering nut and lower bearing cone from bottom of steering sleeve.
 - E. Remove steering sleeve from frame.
 - F. Remove upper bearing cone.
 - G. Clean and inspect bearing cups and cones. If wear or damage is identified, replace bearings.
 - H. If necessary, remove bearing cups from machine frame.

Installation (Fig. 14)

1. If removed, install steering pivot, steering sleeve and bearings to machine:
 - A. If bearing cups were removed from frame, press new bearing cups into frame making sure that cups are pressed fully to the shoulder in the frame.
 - B. Pack bearing cones with grease.
 - C. Place upper bearing cone into upper bearing cup. Slide steering sleeve down through upper bearing and frame.
 - D. Place lower bearing cone on bottom of steering sleeve.
 - E. Install steering nut onto threads of steering sleeve. Torque steering nut from 60 to 90 in-lb (6.8 to 10.2 N-m).
 - F. Apply Loctite #242 (or equivalent) to set screw. Tighten set screw into steering nut to secure assembly. Torque set screw from 90 to 120 in-lb (10.2 to 13.6 N-m).
 - G. Position steering pivot to frame. Slide cap screw down through steering pivot and steering sleeve. Install lock nut and torque from 150 to 200 ft-lb (203 to 271 N-m).
2. Position castor fork to steering pivot and secure in place with four (4) cap screws (item 15).
3. Thoroughly clean tapers of steering cylinder balljoint and balljoint boss in front castor fork.
4. Position steering cylinder ball joint to castor fork. Secure steering cylinder balljoint to front castor fork with two (2) jam nuts. Install first jam nut onto cylinder ball joint threads and torque from 65 to 85 ft-lb (88 to 115 N-m). Then, while retaining first jam nut with wrench, install and torque second jam nut from 65 to 85 ft-lb (88 to 115 N-m).
5. Install front wheel (see Front Wheel Installation in this section).
6. Carefully position hydraulic hoses to fork and install hose guide.
7. Install fuel tank to machine (see Fuel Tank Installation in the Service and Repairs section of Chapter 3 – Engine).

Operator Seat

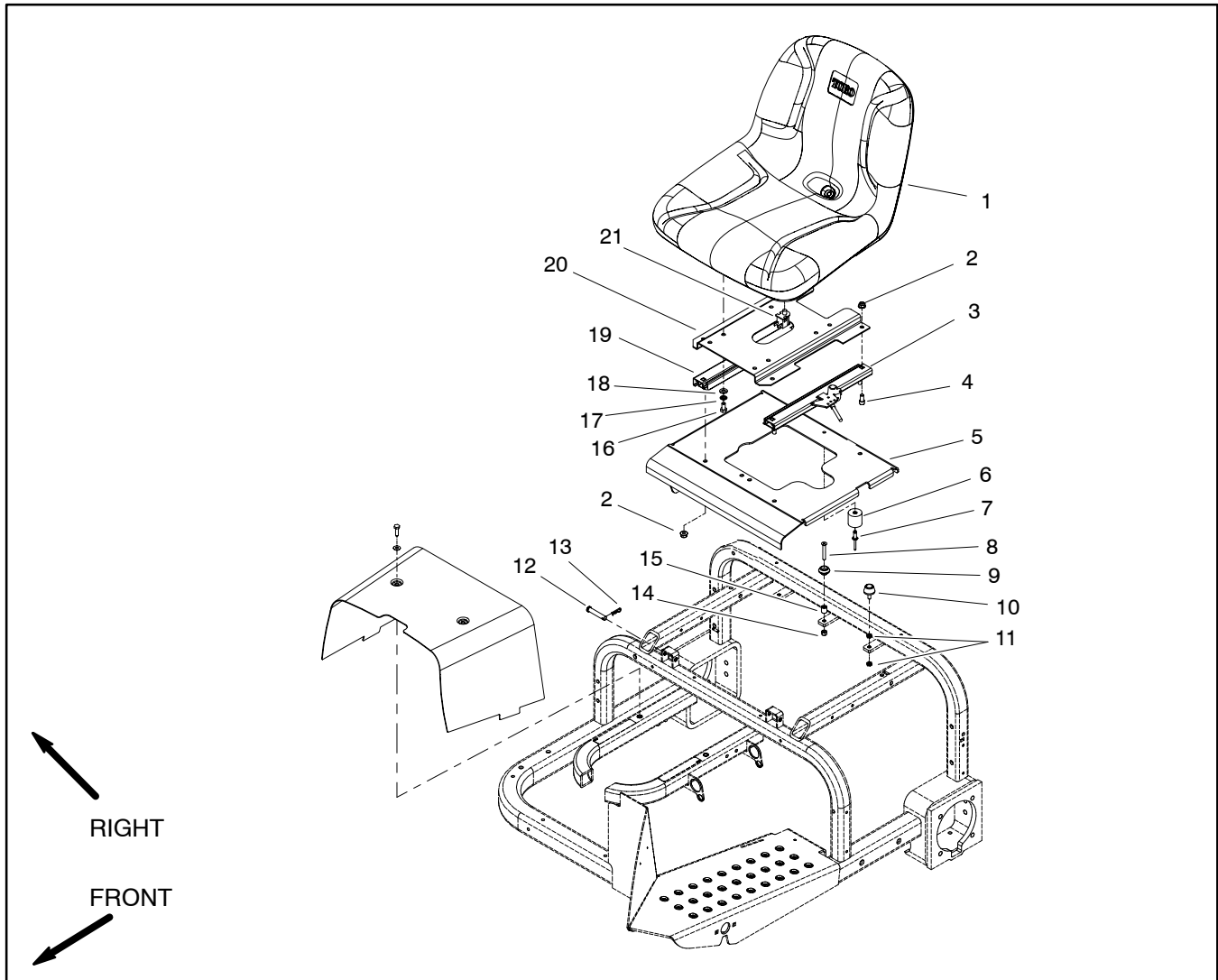

Figure 16

- | | | |
|----------------------------|-------------------------|--------------------------|
| 1. Operator seat | 8. Screw | 15. Spacer |
| 2. Flange nut (8 used) | 9. Holding post | 16. Cap screw (4 used) |
| 3. LH seat adjuster | 10. Bumper (2 used) | 17. Lock washer (4 used) |
| 4. Carriage screw (4 used) | 11. Jam nut (4 used) | 18. Flat washer (4 used) |
| 5. Seat shroud | 12. Clevis pin (2 used) | 19. RH seat adjuster |
| 6. Receptacle | 13. Hair pin (2 used) | 20. Seat base |
| 7. Rivet | 14. Lock nut | 21. Seat switch |

Removal (Fig. 16)

1. Park machine on a level surface, lower attachment, stop engine, apply parking brake and remove key from ignition switch.
2. Tilt seat up and disconnect wire harness electrical connector from the seat switch.
3. Remove seat components as necessary using Figure 16 as a guide.

Installation (Fig. 16)

1. Install seat components using Figure 16 as a guide.
2. Connect wire harness electrical connector to the seat switch.



Electrical Diagrams

Table of Contents

ELECTRICAL SCHEMATIC	3
Electrical Schematic	3
CIRCUIT DIAGRAMS	4
Crank Circuits	4
Run Circuits	5
WIRE HARNESS DRAWINGS	6
Wire Harness Drawing	6
Wire Harness Diagram	7

Electrical
Diagrams

This page is intentionally blank.

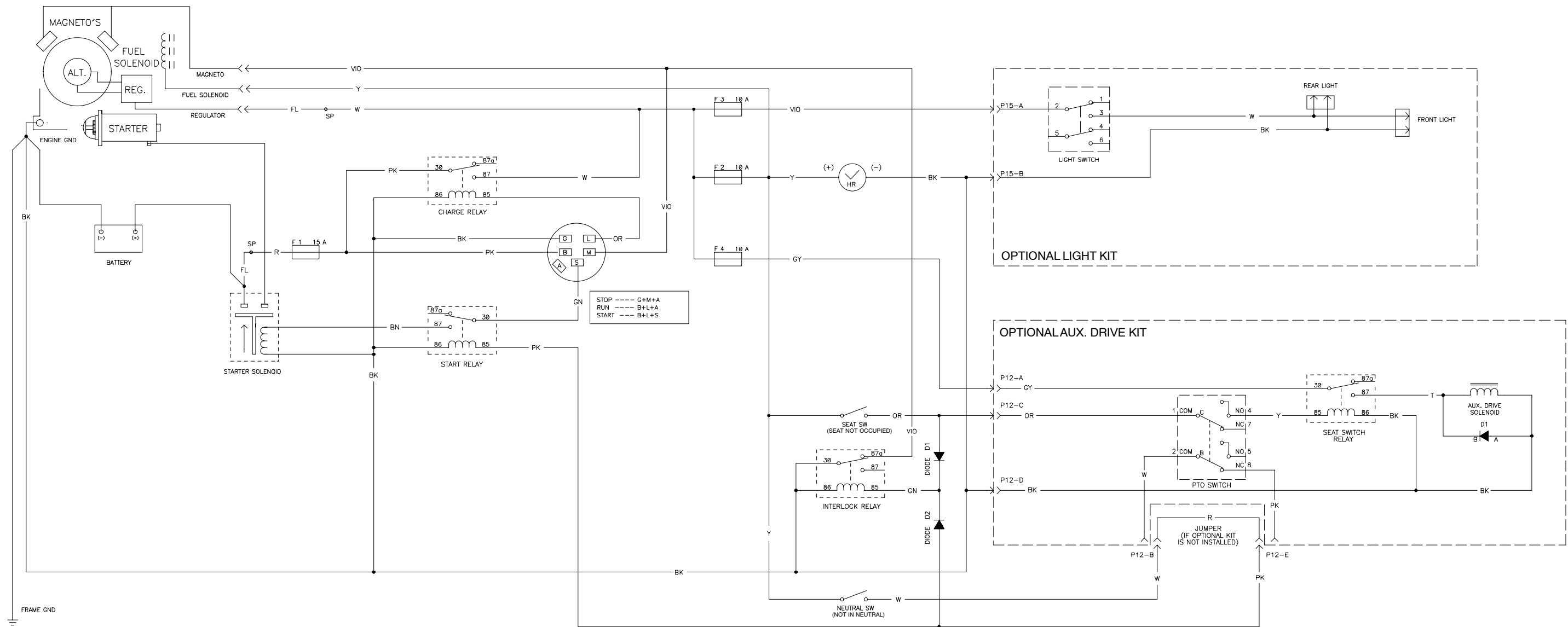

Sand Pro & Infield Pro 3040/5040
Electrical Schematic

All relays and solenoids
 are shown as de-energized.
 All ground wires are black.

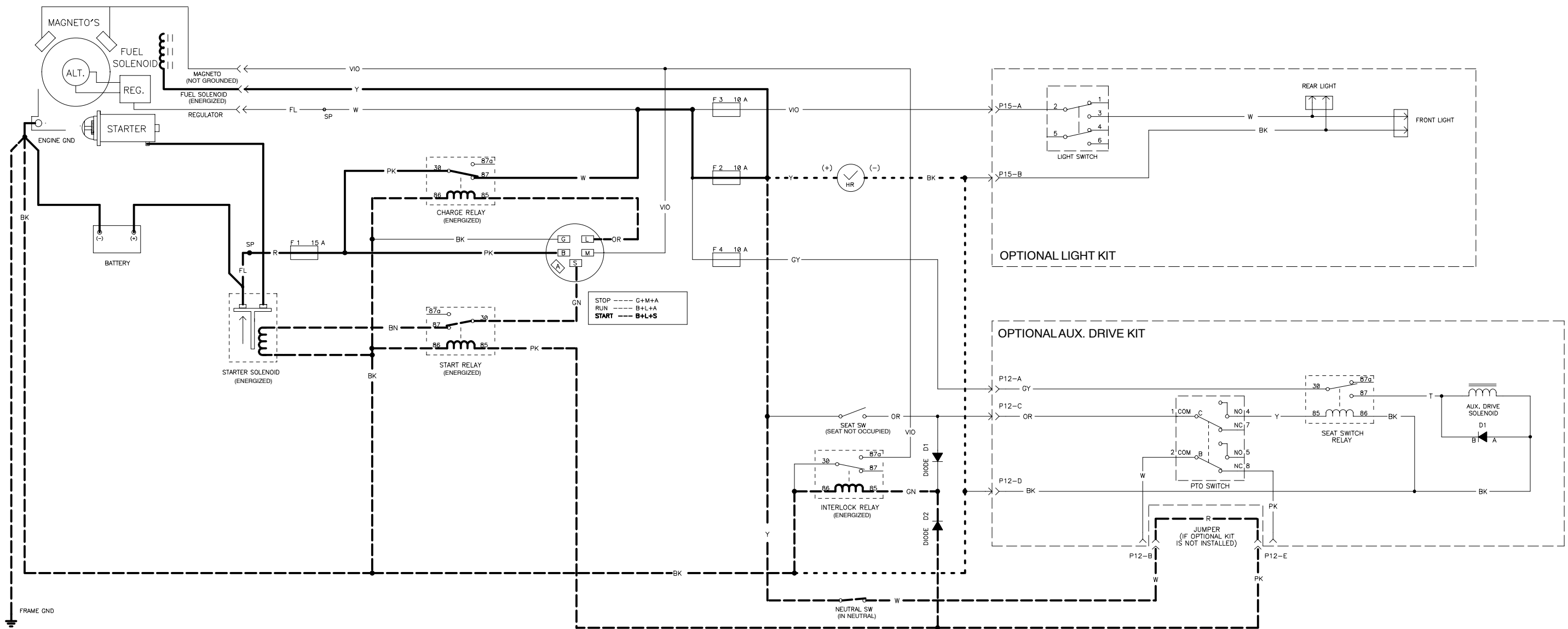

**Sand Pro & Infield Pro 3040/5040
Crank Circuits**

- Power Current
- - - Control Current
- · · Indication Current

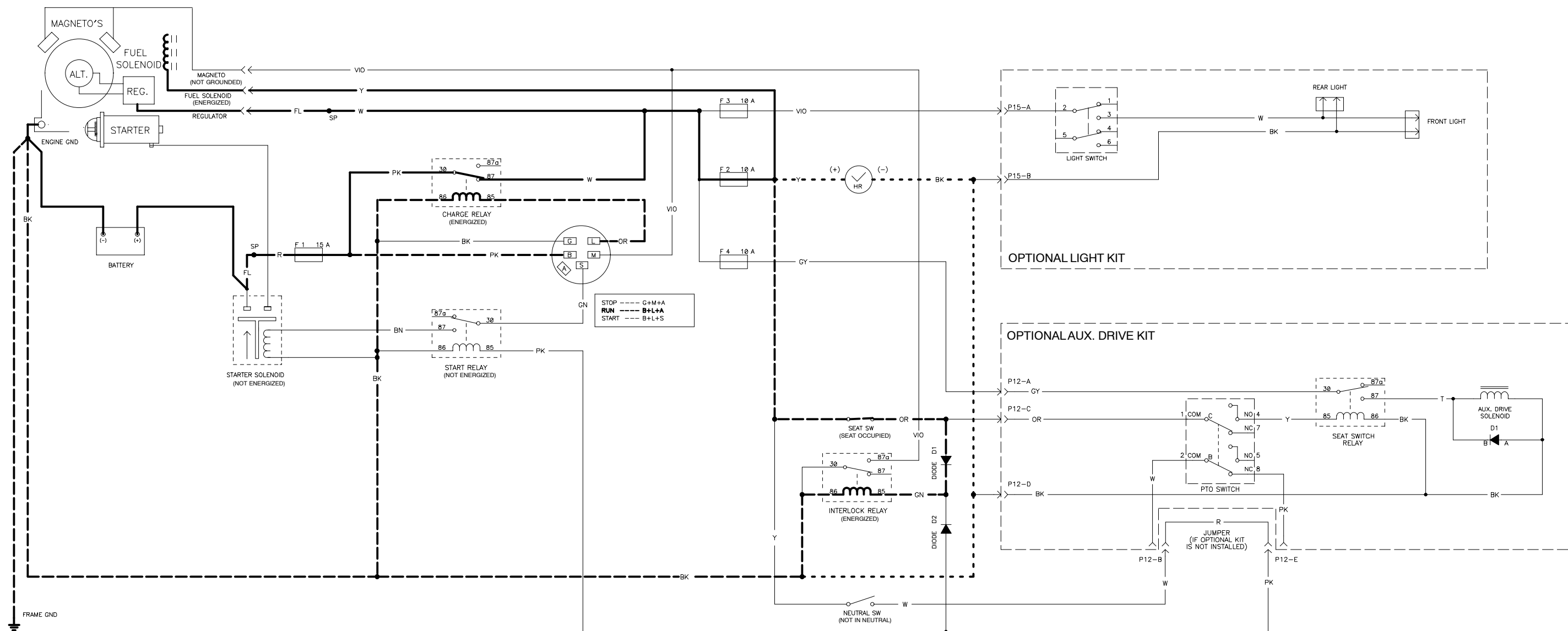

Sand Pro & Infield Pro 3040/5040

Run Circuits

- Power Current
- - - Control Current
- Indication Current

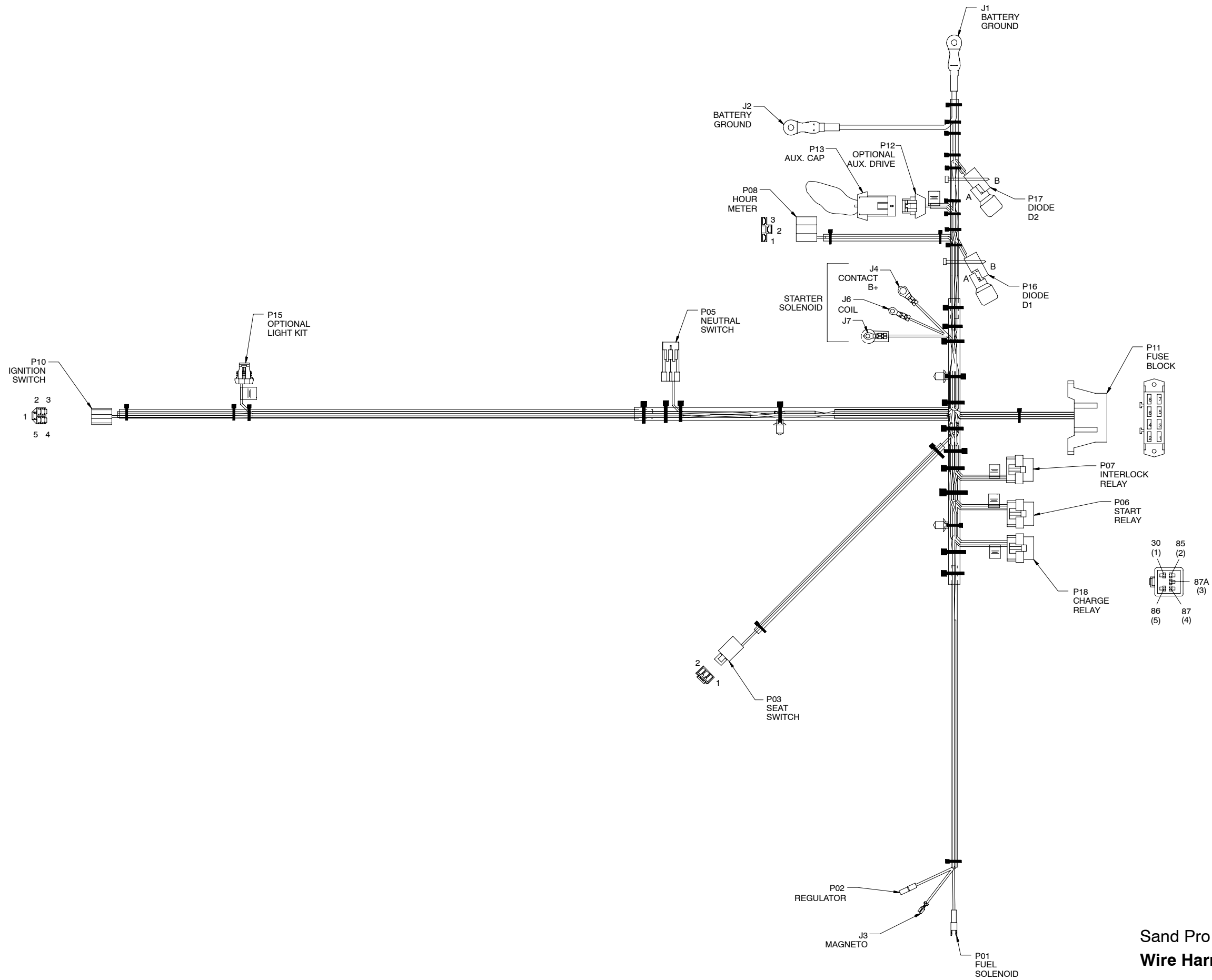

Sand Pro & Infield Pro 3040/5040
Wire Harness Drawing

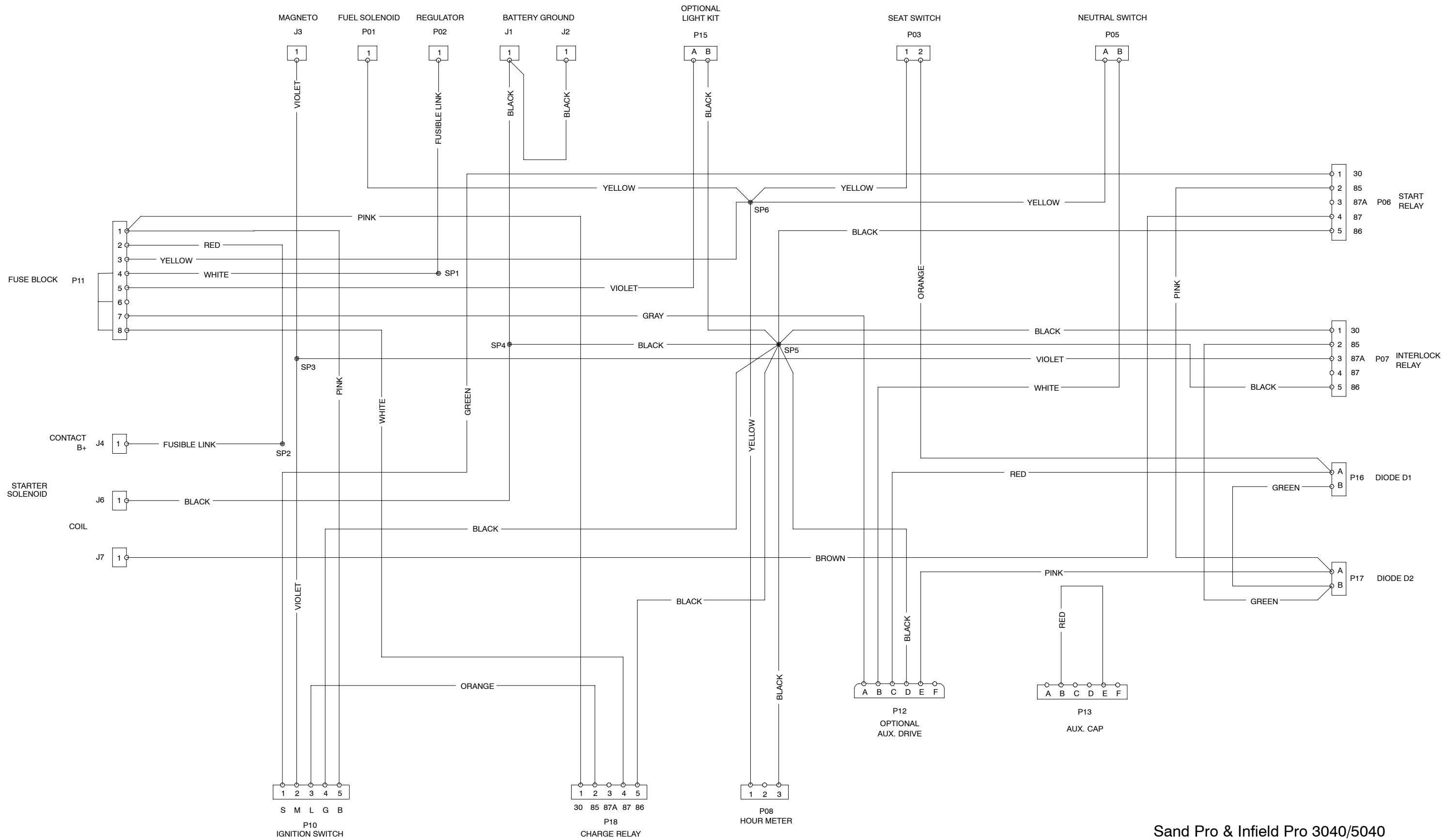

Sand Pro & Infield Pro 3040/5040
Wire Harness Diagram

This page is intentionally blank.