

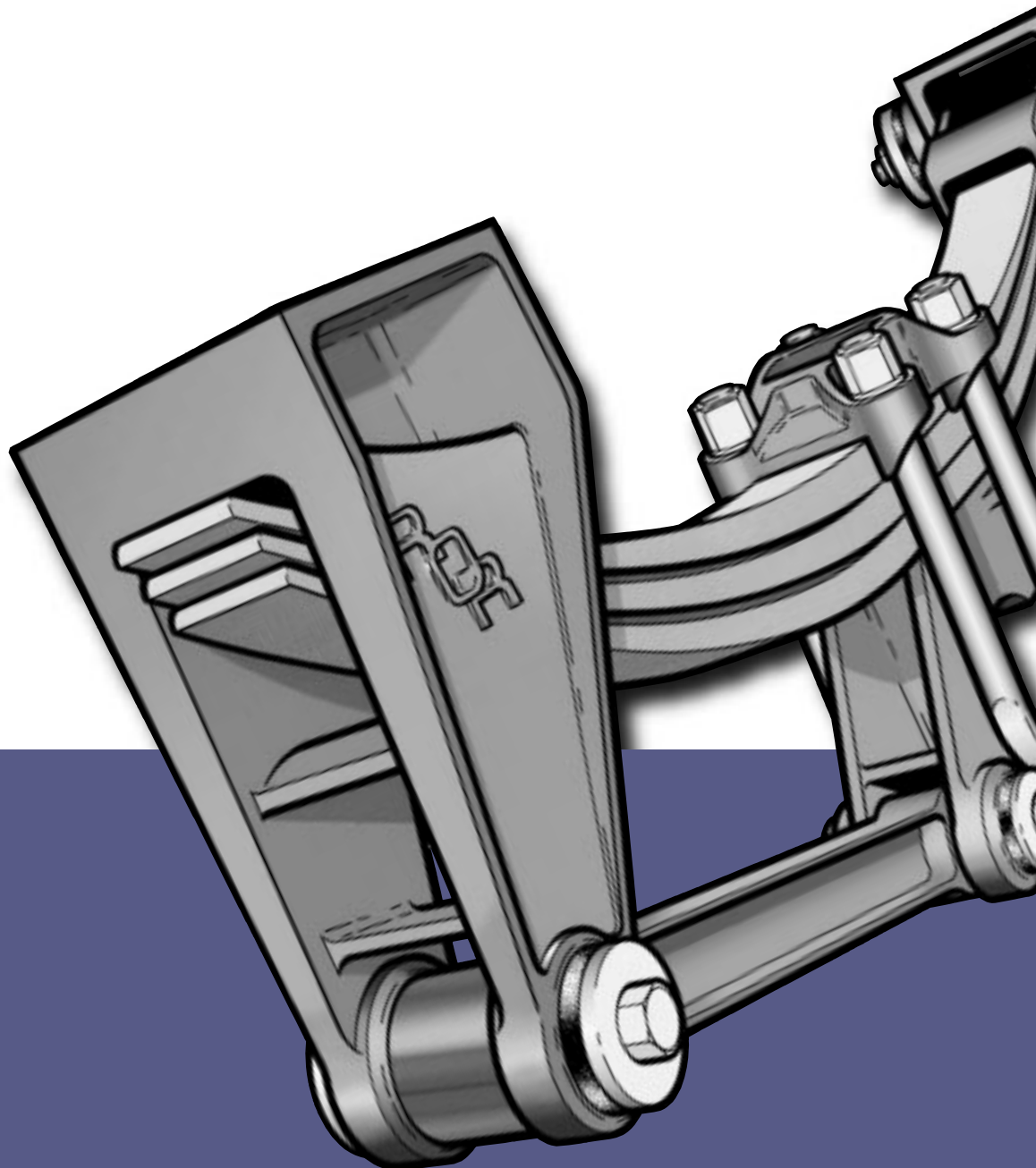

an **ArvinMeritor** brand

Meritor SMT Mechanical Suspension Service Manual



ArvinMeritorTM



an ArvinMeritor brand

SMT Service

INDEX

Section	Description	Page
	THE MERITOR WARRANTY	3
1	FITTING OF HANGER CASTINGS AND EQUALISER BRACKETS Single Axle, Tandem Axle, Tri-axle, Widespread Tandem Axle, Sub-Frame, Check, Gussets, Pipe Brace, Capacity Plate	4
2	ASSEMBLY TO FRAME Fitting Spring Seats and Springs to Axle, Fitting Axle to Trailer Frame, Fitting Spring Retaining Bolts, Equaliser Assemblies, Fitting of Torque Arms, Alignment and Adjustment	5
3	SPRINGS Overslung Applications, Underslung Applications	7
4	OVERHAULING TANDEM SUSPENSION Axle, Equaliser Removal	7
5	ASSEMBLY OF TANDEM SUSPENSION Spring, Torque Arm, Axle	8
6	TAPER LEAF SPRING SUSPENSION	9
7	TRAILER SLOPE	10
8	TRI-AXLE PERFORMANCE	11
9	AXLE CAPACITY RATINGS	11

SMT Service

Meritor Limited Warranty

1. AXLES, MECHANICAL AND FLEXAIR SUSPENSIONS, INDAIR, OTHER MERITOR ACCESSORY PRODUCTS

24 MONTHS PARTS AND LABOUR

Effective 1st March 1989

2. AXLES AND FLEXAIR UNITS ASSEMBLED BY MERITOR

36 MONTHS PARTS AND LABOUR

Effective 1st May 1992

The Company warrants that at its option it will repair or replace without charge any original Meritor axle, suspension, trailer component and any axle and suspension assembly which is found on examination by the Company to be defective as to material or workmanship.

Subject to: such assembly or component having been used solely on a vehicle for which the specification and applications have been approved by the Company's engineering department and in accordance with the approved applications and the vehicle not having been altered from the manufacturer's specification.

This warranty and the obligation to repair or exchange are complete and exclusive. No liability is accepted for special or consequential expenses/damages of any nature. The warranty does not apply to normal wear and tear, abuse, damage caused by accident, failure to lubricate as specified in accordance with manufacturer's instructions, and, if adequate storage facilities and protection are not provided, the damage resulting from deterioration up to the time Meritor products are delivered to the first owner-user.

Allowances for labour will be paid for repair or replacement only as determined and APPROVED by Meritor Service Department BEFORE SUCH LABOUR HAS STARTED.

All claims submitted under this warranty period must be filed in writing with the Meritor Aftermarket Services Division within 60 days from the date of failure and all components involved in the claim must be retained and available for inspection for 90 days from the date of claim being submitted.

No deductions shall be made from remittances or current accounts in respect of any warranty claims whilst those claims are being processed.

All claims must quote component Serial Numbers (where applicable) and relevant vehicle number identification and also assembly Serial Number and manufacturing date code where applicable.

This warranty is in substitution for and excludes all express or implied statutory or other conditions, warranties, guarantees, or liabilities (whether as to fitness for a particular purpose, quality, standard of workmanship or otherwise). Save as provided herein the Company accepts no liability whatsoever for defects in parts or for any injury, loss or damage attributable thereto, howsoever arising (whether direct, indirect or consequential).

Warranty Procedure

Should any Meritor equipment fitted to your trailer become unserviceable within the warranty period, contact the trailer manufacturer or Meritor Service Department who will advise on the appropriate action.

A comprehensive network of original parts distributors and service stations operate throughout Europe; this is supported internationally with agents strategically placed around the world.

Meritor HVS Limited reserve the right to make changes in specifications shown herein or add improvements at any time without notice or obligation.

PARTS SHOWN ARE MADE FROM DRAWINGS IN WHICH COPYRIGHT SUBSISTS. THE MAKING OF COPIES OF ANY OF THESE PARTS IS PROHIBITED.

© Meritor HVS Limited



The high quality assurance management systems applied by Meritor are endorsed with the awarding of ISO 9001, Lloyd's Register Quality Assurance.

SECTION 1

New Suspension

Fitting of Hanger Castings and Equaliser Brackets

Note

It is normal procedure to commence the building of new suspensions in an inverted position.

A. SINGLE AXLE

Position the front hanger bracket by measuring from the king pin to the centre of the casting. The rear hanger position can then be located from the front hanger after reference to the assembly drawing (Fig. 1).

B. TANDEM AXLE

The equaliser is supplied as a complete unit and should be positioned first by taking a measurement from the king pin to the centre of the equaliser bracket. The front and rear hanger castings can then be positioned by measuring from the centre pin of the equaliser bracket to the centre of the appropriate hanger bracket, again after reference to the assembly drawing (Fig. 2).

C. TRI-AXLE

Installation again as above after reference to assembly drawing to ascertain axle centres (Fig. 3).

D. WIDESPREAD TANDEM AXLE

Here again the position of the suspension is determined by a measurement taken from the king pin to the centre of the suspension. From this mark, the position of the equaliser hanger brackets can be located as previously (Fig. 4).

E. SUB-FRAME

When installing a suspension to a sub-frame, check the sub-frame for squareness before the equaliser bracket position is found. The front and rear hanger brackets can then be positioned from the equaliser bracket, and the sub-frame set in position on the trailer by taking a measurement from the king pin to the centre of the equaliser brackets (Fig. 5).

F. CHECK

All castings should firstly be tack welded in place. A careful check should then be made to ensure that the hangers and brackets are correctly located and are square with the frame. Final welding can then be carried out.

Welding to be carried out with low hydrogen electrode with a minimum of 8mm fillet weld around all sides of the bracket.

G. GUSSETS

It is recommended that gussets are fitted in all instances where brackets are welded to underside of frame (Fig. 6).

H. PIPE BRACE

After all hangers and equalisers have been installed, cut pipe braces to fit between right and left front hangers, equaliser brackets and rear hangers on widespread and tri-axle suspension. For positioning of braces see Fig. 6, cut length to suit, recommended size 60mm O/D x 4.00mm wall minimum.

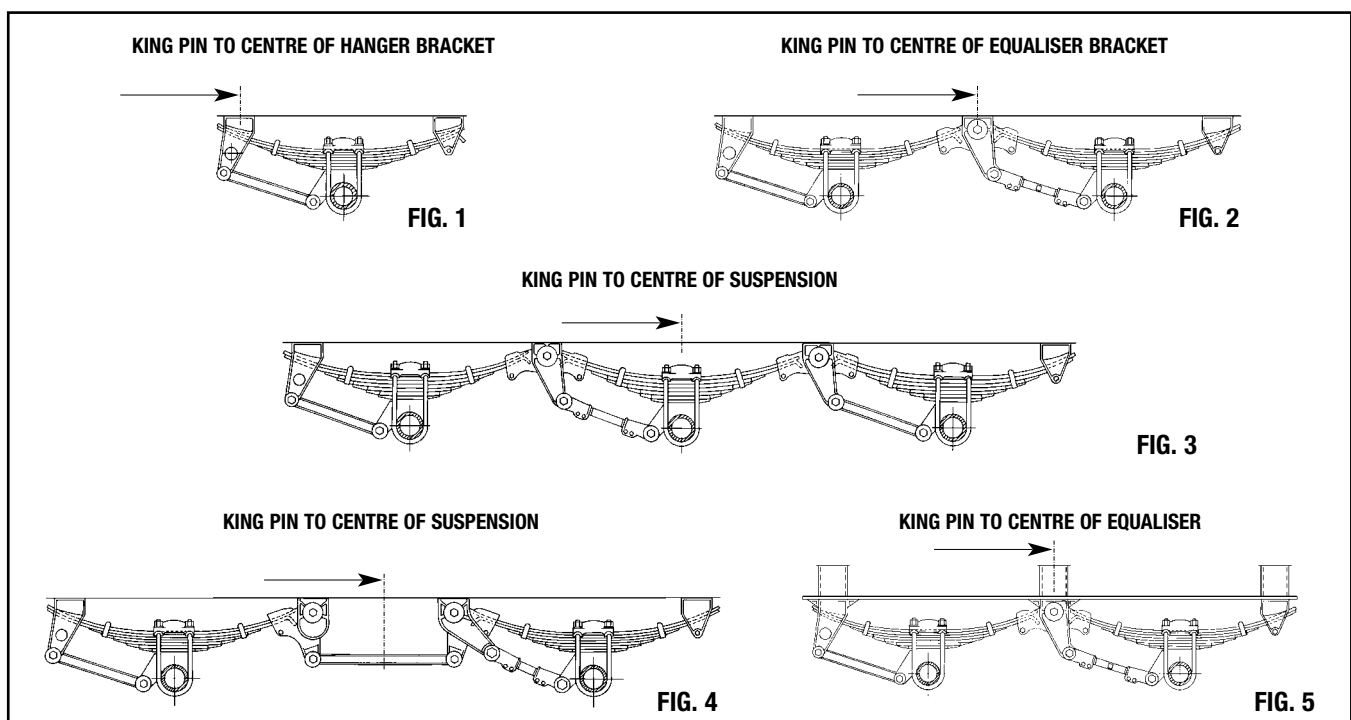

SMT Service

I. CAPACITY PLATE

Trailer manufacturers should ensure that the identification plate riveted to either of the rear hanger brackets corresponds with the correct capacity of the running gear to facilitate future plating of the vehicle.

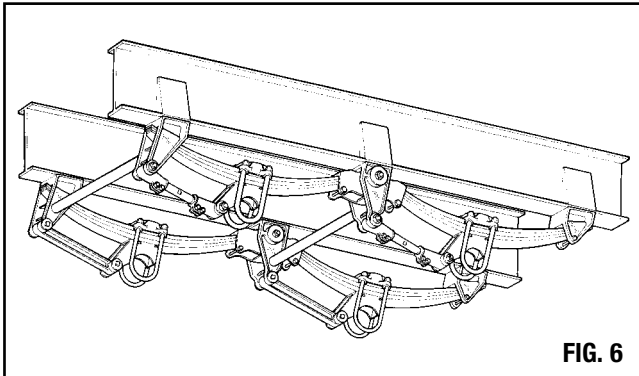

FIG. 6

SECTION 2

New Suspension

Assembly to Frame (Tandem)

Note

One important aspect of assembly which should always be closely watched is the allowance of sufficient clearance in the positioning of air cylinder brackets, etc., for the withdrawal of torque arm bolts and the equaliser bolt. Compliance with this can save time, money and temper.

A. FITTING OF SPRING SEATS AND SPRINGS TO AXLE

- (i) Weld spring seats into position on axle to pre-determined centres. For spring centres, see page 11 and Axle section for Beam Welding procedure.
- (ii) Lift springs on to spring seats, and position "U" bolts on axle beam ensuring they are as close as possible to the Spring Seat.

- (iii) When "U" bolts are in position place top plate in position on springs and fit washers and nuts onto "U" bolts. Recommended torque 52-55 kgf m.

B. FITTING AXLE TO TRAILER FRAME

Position axle and spring assembly under trailer frame inserting the springs, first into front hanger bracket and then into equaliser bracket.

C. FITTING SPRING RETAINING BOLTS

Fit spring retaining bolts (A) and nuts in position in equaliser bracket (Fig. 7) and tighten. Lower axle. Repeat for rear axle.

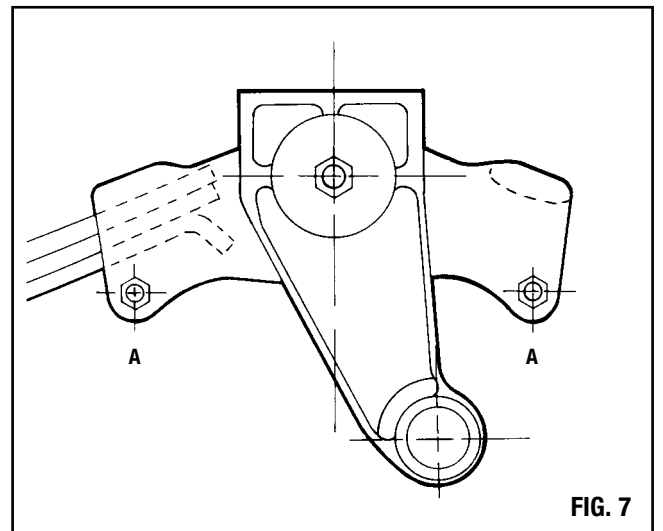

FIG. 7

Note

When assembling the springs on the widespread suspension it is most important that the spring retaining bolt marked "X" should be fitted to the FRONT equaliser only (Fig. 8). Under no circumstances should a bolt be fitted to the REAR equaliser. Failure to observe this instruction will result in restricted equaliser movement and possible damage to the suspension unit.

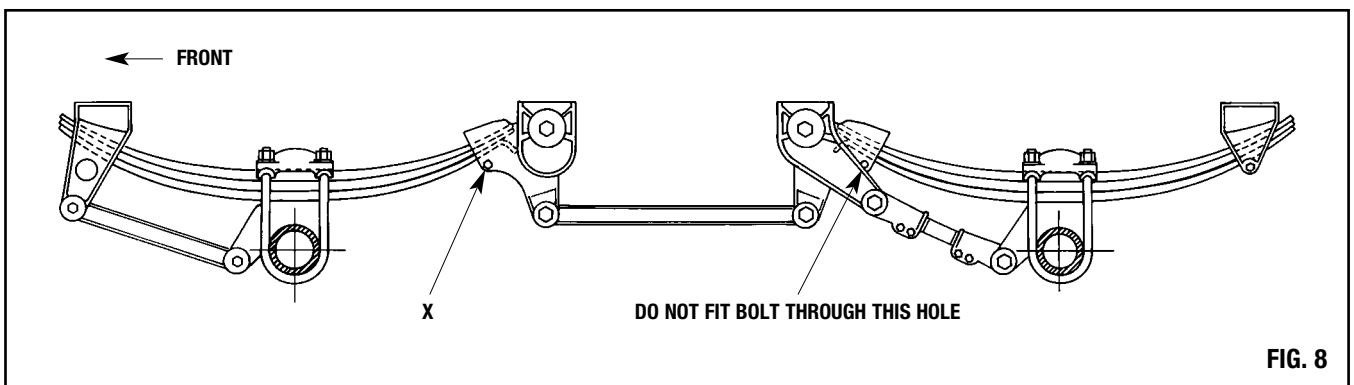

FIG. 8

SMT Service

D. EQUALISER ASSEMBLIES, SMT

Equaliser assemblies when supplied are handed for ease of maintenance. However, it should be noted by the trailer builder that the equaliser assembly can be installed two different ways: one, with the head of the equaliser bolt facing outwards – this is the way that Meritor would prefer it to be installed, because the equaliser bolt can easily be removed in the event of the bushes being replaced.

Alternatively, if the trailer builder's preference is for the equaliser bolt nut to be on the outside then sufficient clearance must be allowed under the trailer for the removal of the equaliser bolt so that again the bushes can be replaced when required.

E. FITTING OF TORQUE ARMS SMT SERIES

Adjustable torque arms fitted kerb side. Install torque arms between hanger bracket lugs: dip torque arm bushings into a solution of 50% water and 50% liquid soap. Then insert from each side into hanger bracket and torque arm bores. Tap bushings into position with hide hammer to ensure no damage is done to bushes. Fit torque arm bolt, clamp washer and nut. To ensure correct location of torque arm and to avoid metal to metal contact at the four points marked "A", it may be necessary to fit special spacers as shown in Fig. 9. This will prevent the torque arm being pulled off centre, and prevent excessive build up of rubber under head of bolt as shown in Fig. 10.

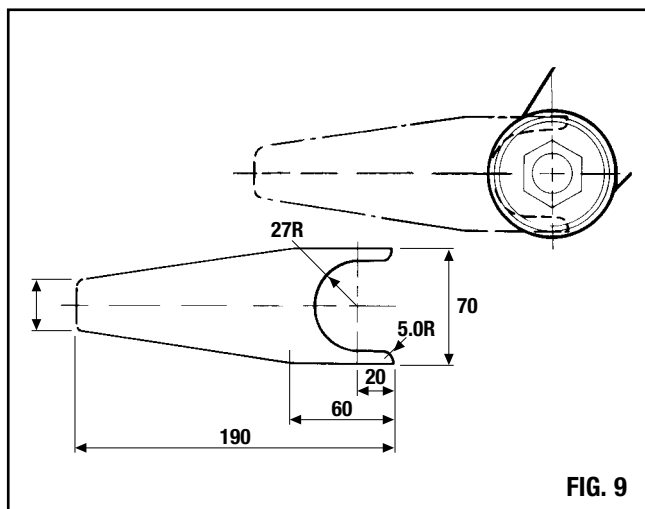

When thickness of rubber under head of bolt approximately 2mm remove spacer from under clamp washer and tighten nut to 30-35 kgf m (215/260 lbf ft). Remove spacer between torque arm and inside wall of hanger bracket.

F. ALIGNMENT AND ADJUSTMENT

Commence alignment by measuring from the centre of the fifth wheel king pin to the outside centre of the front axle. Adjust by turning torque arm screw until the dimensions X-X are within 1.5mm of each other. Tighten clamp bolts to recommended torque. Alignment of the rear axle is then carried out using the same procedure as with the front axle until the dimensions Y-Y are within 3mm of each other (Fig. 11). Tighten clamp bolts.

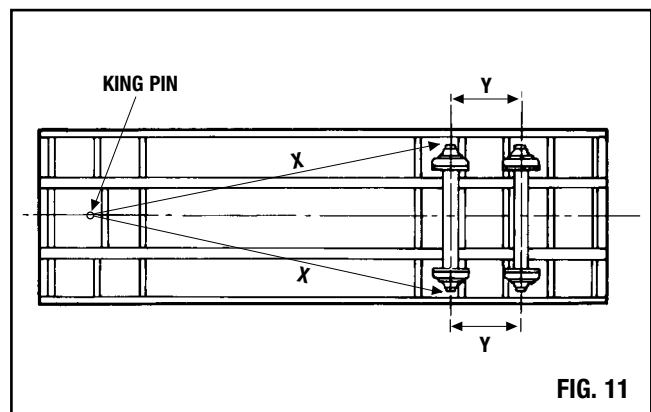
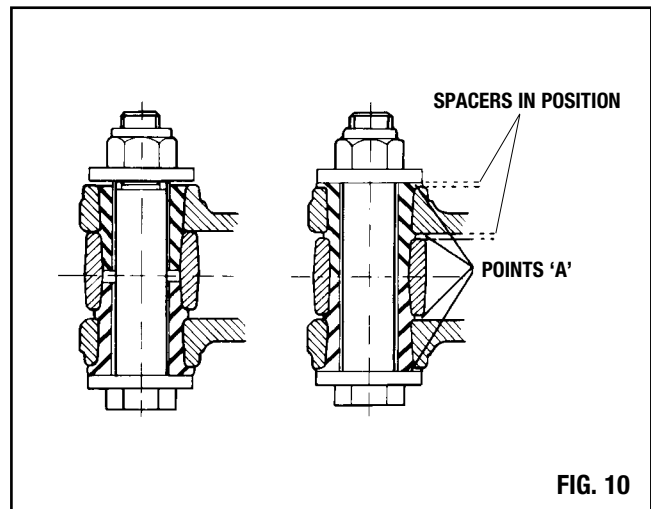

Note

Torque arms with 12mm dia. bolts should be tightened to 10 kgf m (70 lbf ft) (Fig. 12). After a period of running in, check all nuts for correct torque, then again after 1,000 km, and subsequently at every 10,000 km intervals. Check all nuts for correct torque. The equaliser bolt should be checked for torque at 30/36 kgf m (215/260 lbf ft).

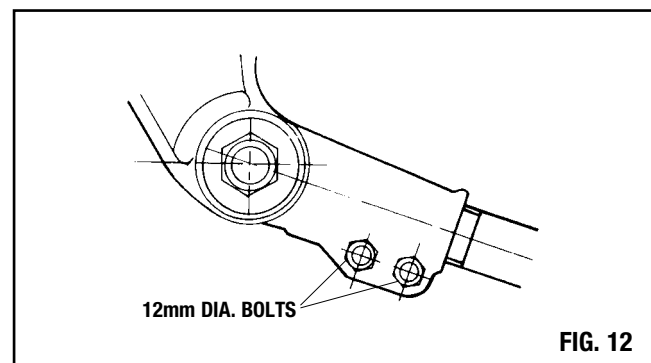

SMT Service

SECTION 3

Springs

OVERSLUNG APPLICATION

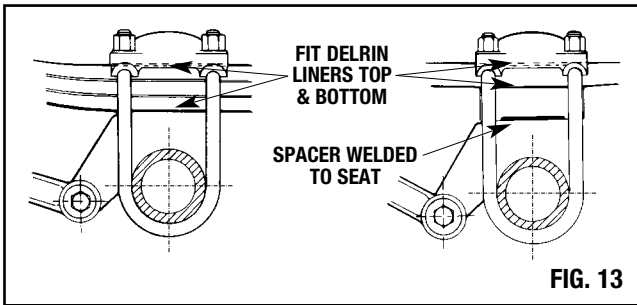

FIG. 13

Range of springs for the SMT (standard axle spreads only) are as follows:

- (a) Single Leaf – recommended torque 52/55.5 kgf m (375/400 lbf ft),
- (b) Two/Three/Four Leaf Parabolic – recommended torque 52/55.5 kgf m (375/400 lbf ft),
- (c) Multi-Leaf – recommended torque 52/55.5 kgf m (375/400 lbf ft).

Note: When fitting single leaf, two, three and four leaf parabolic springs, it is imperative that Delrin liners are fitted top and bottom as shown in Fig. 13.

UNDERSLUNG APPLICATION

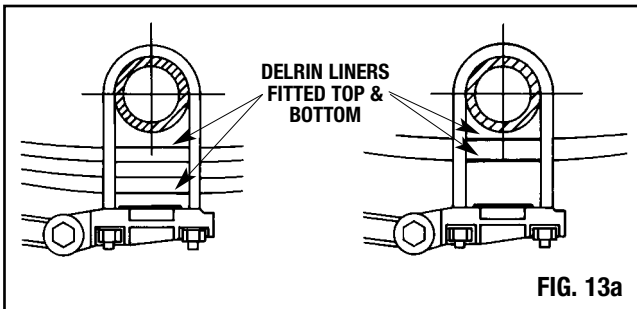

FIG. 13a

Range of springs for the SMT (standard axle spreads only) are as follows:

- (a) Single Leaf – recommended torque 62/65 kgf m (450/475 lbf ft),
- (b) Two/Three/Four Leaf Parabolic – recommended torque 62/65 kgf m (450/475 lbf ft),
- (c) Multi-Leaf – recommended torque 62/65 kgf m (450/475 lbf ft).

Note: When fitting single leaf, two, three and four leaf parabolic springs, it is imperative that Delrin liners are fitted top and bottom as shown in Fig. 13a.

Caution

Do not strike an arc on U bolts, leaf springs and axles except at designated points; when welding in close proximity to these parts they should be protected from weld spatter.

SECTION 4

Maintenance

Overhauling Tandem Suspension

- (i) The trailer should be jacked up until the wheels are just clear of the ground, and then firmly secured on strong trestles. This removes all imposed weight from the suspension and ensures that any work required underneath the trailer is carried out in safety.

A. AXLE

- (ii) Remove wheels and any air piping and other load sensing attachments on axle.
- (iii) Slacken handbrake.
- (iv) Remove handbrake linkage from slack adjusters.
- (v) Remove torque arms from axles and hanger brackets.
- (vi) Jack up front axle. Remove “U” bolt retaining nuts, washers and spring top plate. Remove “U” bolts. Lower axle and remove jacks. Axle can now be rolled out of the way.
- (vii) Remove spring retaining bolt from equaliser. Remove road spring. Repeat for other side (Fig. 14).
- (viii) Remove rear axle in the same way.



FIG. 14

B. EQUALISER REMOVAL SMT

Untighten nut then remove equaliser bolt (Fig. 15).

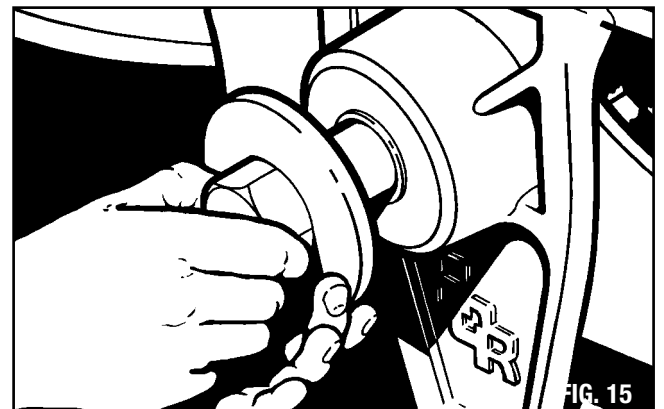

FIG. 15



an ArvinMeritor brand

SMT Service

SECTION 5

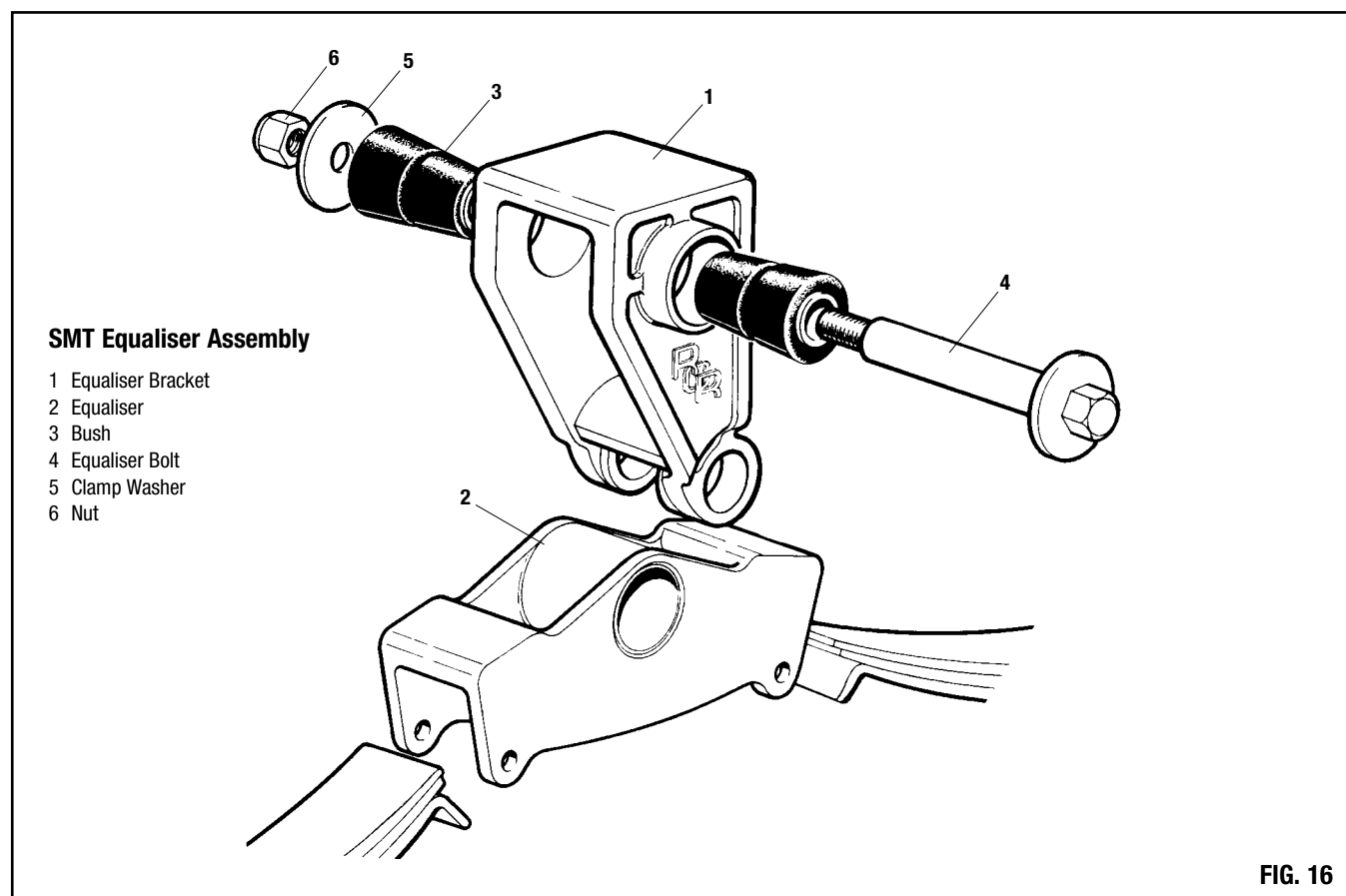

FIG. 16

Assembly of Tandem Suspension

A. EQUALISER ASSEMBLY

Locate equaliser assembly in hanger bracket. Smear two tapered bushes with soap solution on outer faces only, then insert bushes into either side of the hanger bracket driving them into the equaliser as far as possible with a nylon hammer. The equaliser bolt can then be pushed through the bush bores. Complete assembly with clamp washer and nut. Tighten nut to a torque of 30/36 kgf m (215/260 lbf ft). To ensure correct location of equaliser it is advisable to manufacture a special spacer. This will prevent the equaliser being pulled out of centre when the nut is tightened. For details of spacer see page 6.

B. SPRING

Fit spring into position making sure that lipped end of spring is inside equaliser (Fig. 17). Insert spring retaining bolts into equaliser. Fit washers and nuts to spring retaining bolts "A" and tighten. If a new spring is to be fitted make sure that preserving grease is only removed from area covered by top plate and spring seat. See notes regarding fitting of taper leaf spring (page 9).

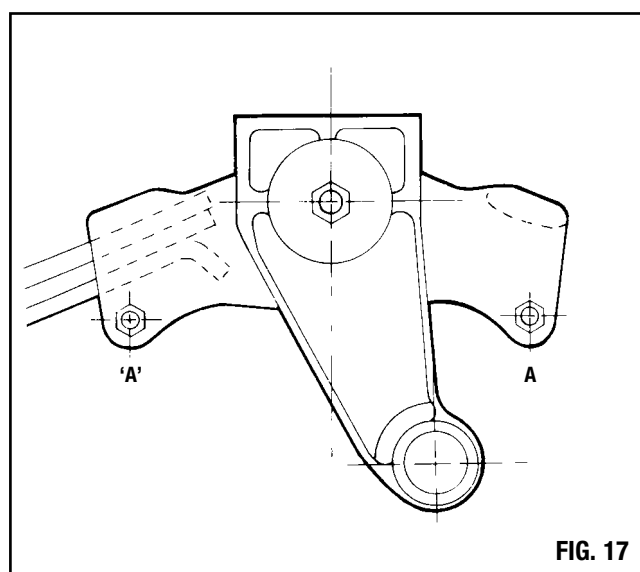

FIG. 17

SMT Service

C. TORQUE ARM

Follow procedure outlined under fitting of torque arms on page 6.

- (i) Fit adjustable torque arms to front hanger brackets on kerb side of vehicle. Be sure that the slots of the clamp point downwards, except on special underslung application.
- (ii) Insert bolt through torque arm bushes and fit flat washer. Fit nut onto bolt but do not fully tighten. Tighten clamp bolts but not to full compression.
- (iii) Repeat operation 5(c) and 5(d) for rear axle, fitting adjustable torque arm to equaliser bracket.
- (iv) Repeat operation 5(c), 5(d) and 5(d(i)) for fixed torque arm to road side.

D. AXLE

- (v) Roll axle into position and raise until spring seat makes contact with underside of spring. Place top pad in position.
- (vi) Insert "U" bolts on spring seat and top plate. Fit washers and nuts. Line up springs so they are at right angles to axle centre line.

Follow procedure outlined under fitting of torque arms on page 6 and tighten nut to 30/36 kgf m (215/260 lbf ft).

- (vii) Repeat operations (iv), (v) and (vi) for rear axle.
- (viii) Refit handbrake linkage to brake adjusting lever using new split pins.
- (ix) **Air Chamber**
Fit air chambers to brackets inserting the two holding bolts through holes in the bracket, fitting washers and then screwing nuts home.
- (x) Fit air chamber connecting rod to brake linkage and secure by inserting split pin through retaining shaft.
- (xi) Finally tighten nuts holding air chamber to bracket.
- (xii) Carry out alignment and adjustment procedure as described in operation "f" (alignment and adjustment) of installation for new suspensions on page 6.
- (xiii) Tighten torque arm clamp bolts to 10 kgf m (70 lbf ft) (Fig. 18).
- (xiv) Fit road wheel and remove jacks from under axle.

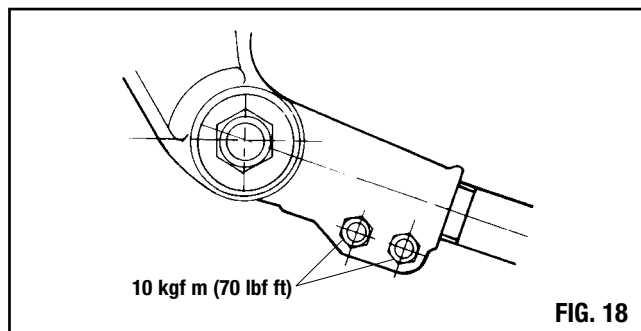

FIG. 18

SECTION 6

Fitting Conversion of Monoleaf Spring Suspension

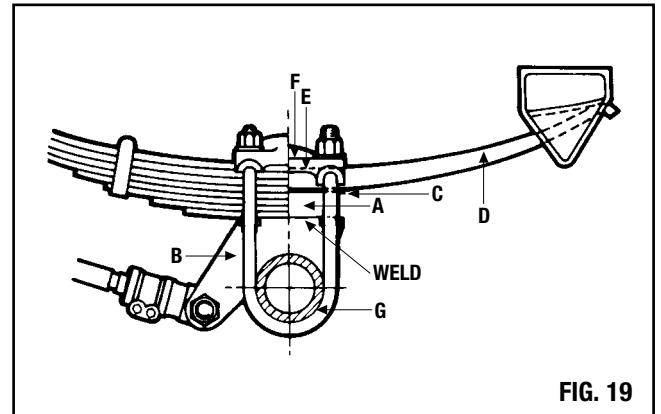

FIG. 19

Installation is similar to the standard multi-leaf suspension and the instructions given for the latter should be closely followed. However, due to the reduced depth of the spring certain additional parts are required in order to maintain the necessary mounting height. Spacer block "A" (Fig. 19) is placed on top of the spring seat "B" and securely welded using the recessed area at either end of the block, care being taken to ensure the top faces are square to the spring seat faces.

The Delrin liner "C" with hole is then placed on the top face of the spacer block, and the location dowel on the underside of spring "D" located in the spacer block dowel hole. The liner "E" without a hole, is then placed between the top of the spring and the spring top plate "F". Fit "U" bolts "G" and secure with washers and nuts. Line up the springs so that they are at right angles to the axle centre line. Tighten "U" bolt nuts to 52 kgf m (375 lbf ft).

Conversion kits are available as shown in table above.

Spring Seat Thickness Dimension	Replacement Kit No.
68mm	A/16
68mm	B/16
93mm	A/17
93mm	B/17

The taper leaf kit will give the same unladen frame height as the multi-leaf spring it replaces. The fully-laden frame height will be about 25mm (1") higher when taper leaf springs are fitted.

SECTION 7

Trailer Slope Relative to Spring Seat Heights

When considering the axle and suspension to be specified for a new trailer, always take into account the angle of slope as shown in Fig. 20. If this angle is greater than that specified against each type of suspension shown below in the laden condition, the equaliser will have excessive tilt (see Fig. 21). This tilt will reduce the equaliser movement, causing the equaliser to strike the frame under uneven road conditions.

This can be overcome by specifying spring seats 25mm (1") higher on the forward axle than the seats at the rear (see Fig. 22); or alternatively, by welding packing pieces 25mm thick to the existing spring seats (see Figs. 23 and 24). Shown in Fig. 23 is the same malfunction on a widespread suspension. A packer of appropriate thickness welded in position will correct this, as shown in Fig. 24. Alternatively, the addition of a suitable tapered spacer welded between the hanger bracket and the main frame will achieve the same result.

Tandem Suspension: One in one hundred (1:100)
 Widespread Suspension: One in one hundred and fifty (1:150)
 Tri-Axle: One in two hundred (1:200)

If the angle of slope is greatly in excess of the above slopes, a packer of greater depth than the 25mm will be required to combat the equaliser tilt.

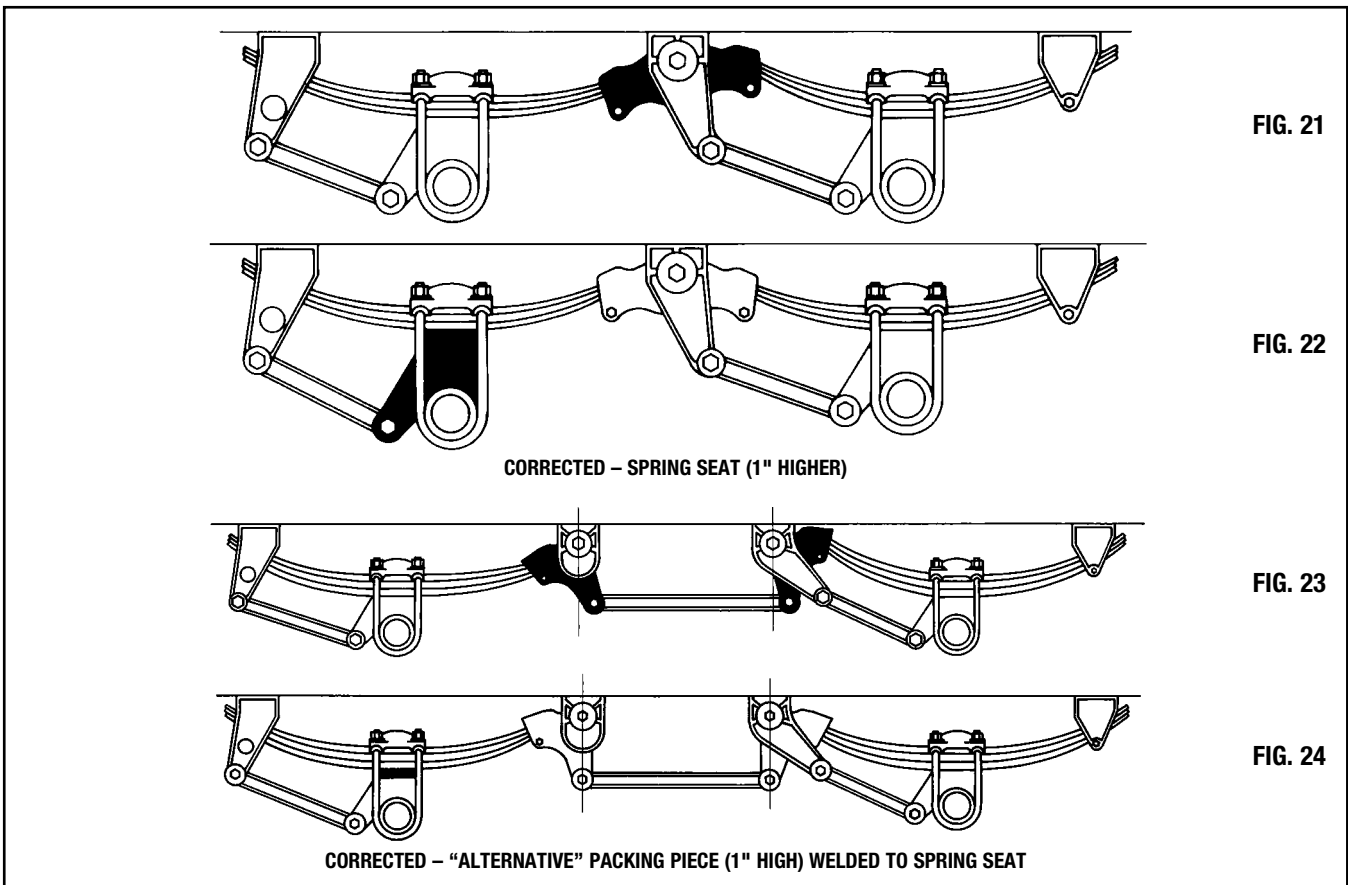
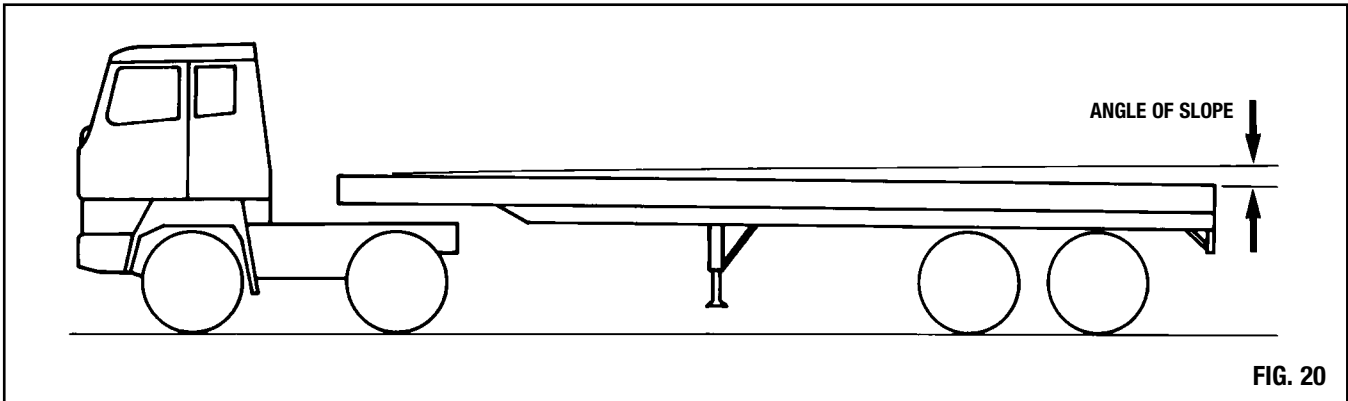

SMT Service

SECTION 8

Tri-Axle Performance

Investigations into the performance of trailers fitted with tri-axle suspensions have shown that installation is more critical than for tandem suspensions. The platform slope in the laden condition, if above the recommended maximum quoted, has apart from reducing equaliser travel, a critical effect on axle loadings.

High axle loadings can cause excessive tyre wear or even failure, particularly when cornering. Therefore it is imperative when installing a tri-axle suspension that particular attention should be paid to the laden trailer's slope. If the slope is greater than one in two hundred, the packing pieces must be welded to the spring seats on the front and centre axles; the deepest being fitted to the front axle.

The depth of packing can only be determined by considering each installation individually after judging fifth wheel height, wheel base etc. When a steering axle is required Meritor Engineering Department should be consulted.

The laden ride height of fifth wheel must also be taken into consideration when determining trailer slope. If a variation greater than plus or minus 15mm is expected from the specified slope, a tri-axle suspension will not properly compensate. The preceding criteria are not applicable to multi-axle air suspension configurations. For details of mount heights, weights etc, please send for Meritor's air suspension literature and specification.

SECTION 9

Certified Axle Capacity Ratings

Series No.	Nominal Axle Rating	Maximum Offset Track – Spring Centres
"TM" 20000	9.25 Tons	18.5"
	9400 Kg	470mm
"TM" 22500	10 Tons	19.25"
	10160 Kg	489mm
"TM" 25000	11.5 Tons	19.25"
	11680 Kg	489mm
33000	14 Tons	19.25"
	14220 Kg	489mm

Ratings shown are for normal highway applications and may vary with special applications and service. All special applications must be approved by Meritor Design Engineering Department.

Meritor HVS Limited
Commercial Vehicle Systems
Rackery Lane, Llay
Wrexham LL12 0PB
U.K.
Telephone: +44 (0)1978 852141
Fax: +44 (0)1978 856173

Meritor HVS (Mityr-Mory) S.A.
Commercial Vehicle Systems
Z.I. du Moulin à Vent
9 rue des Frères Lumière
77290 Mityr-Mory
France
Telephone: +33 (0)1 64.27.44.61
Fax: +33 (0)1 64.27.30.45

Meritor HVS (Verona) s.r.l.
Commercial Vehicle Systems
Via Monte Fiorino, 23
37057 San Giovanni Lupatoto
Verona
Italy
Telephone: +39 045 8750399
Fax: +39 045 8750640 / 8750513

Meritor HVS (Barcelona) S.A.
Commercial Vehicle Systems
Ctra. Granollers - Sabadell Km. 13,3
Poligono Argelagues
08185 Lliçà de Vall
Spain
Telephone: +34 (9)3 843 95 68
Fax: +34 (9)3 843 83 59

ArvinMeritor Inc.
World Headquarters
2135 West Maple Road
Troy, Michigan 48084
U.S.A.
Telephone: +1 248 435 1000

ArvinMeritor
Commercial Vehicle Aftermarket AG
Neugutstrasse 89
8600 Dübendorf
Switzerland
Telephone: +41 (0)1 824 8200
Fax: +41 (0)1 824 8264

ArvinMeritor
Commercial Vehicle Systems
Postbus 255
5700AG Helmond
Churchillaan 204A
5705BK Helmond
Holland
Telephone: +31 (0)492 535805
Fax: +31 (0)492 547175

ArvinMeritor South Africa
Commercial Vehicle Systems
Telephone: +27 (0) 83 602 1603

For further information contact

Meritor HVS Limited
Commercial Vehicle Systems
Rackery Lane, Llay
Wrexham LL12 0PB
U.K.
Telephone: +44 (0)1978 852141
Fax: +44 (0)1978 856173

www.arvinmeritor.com

© Copyright 2001
Meritor Automotive
All rights Reserved

Publication 4.01.4

Descriptions and specifications were in effect at the time of publication and are subject to change without notice or liability. Meritor reserve the right to make design improvements, change or discontinue parts at any time.

ArvinMeritor™