



**! Safety Rules:**

**WARNING:** Failure to follow these warnings and assembly instructions could result in serious injury or death.

- Immediately discard any plastic wrapping.
- Never allow children to fold, assemble or disassemble the stroller.
- Maximum weight capacity for the Single stroller is 50 lbs. or 22.7 kg. Double 100 lbs. Or 45.4 kg. However, in the Double model the weight of 1 child should not exceed 50 lbs. or 22.7 kgs.
- Never place child in stroller on their back with their head forward and feet rearward.
- Avoid serious injury from falling or sliding out. Always use seat belt.
- Never leave child unattended.
- Never use this stroller with roller skates or in-line skates.
- Never allow stroller to be used as a toy or allow children to give rides to others.
- Never use stroller if it becomes damaged.
- Always be aware of traffic around you when walking or jogging.
- Always engage brakes when you stop or when you let go of handle.
- Always use wrist strap.
- Accessories or parcels placed in or on the stroller may cause it to become unstable.
- Maximum weight for objects in back pouch is 2.2 lbs. or 1 kg. Double 2.2 lbs. or 1 kg. in each back pouch. Excessive weight may cause a hazardous, unstable condition.
- Child may slip into leg openings and strangle. Never use in a reclined carriage position unless T-shield and shoulder strap placement has been readjusted to the seat's new position.



{Figure 1.a}

**IMPORTANT:** Read and follow these Safety Rules and Assembly Instructions before operating stroller. If you have any questions concerning the safe use of this product, contact Pacific Cycle at 1-800-242-6110, M-F, 8:00 a.m.-5:00 p.m. CST or visit us at [www.instep.net](http://www.instep.net) or E-mail us at [info@instep.net](mailto:info@instep.net) before using.

**IMPORTANT:** Tires are shipped deflated, DO NOT OVERINFLATE. Please inflate slowly, with short bursts, to 20-25 PSI maximum. 25 PSI will provide a comfortable ride for your child.

**PLEASE DO NOT RETURN PRODUCT TO THE STORE.** To ensure prompt and correct handling of problems, or to answer questions, please contact us at either our Toll-Free Customer Service number (1.800.242.6110) or E-mail us at [info@instep.net](mailto:info@instep.net). Service will be quicker if you have your model number (found on the product and box) along with this instruction sheet ready when calling. If you have any questions concerning the safe use of this product, please contact us immediately.



Parts List: Description	Qty.
Frame assembly with seat, canopy, and wrist strap	1
Front Wheel	1
Parent Console (not on all models)	1
Under-seat Basket (not on all models)	1
Rear Wheels	2
Front Fender	1
#8 – 11.2" Phillips head screws	4

**Tools Required:** Phillips screw driver, adjustable wrench.

### Stroller Assembly Instructions

**Unfold Stroller:** Remove from carton and remove any packaging materials that may be holding the frame in closed position. Grasp frame handle and open. Lock both plastic latches, on sides, onto the lower frame, insert locking pin into hole in latch and frame, lock the pin in place by slipping the wire loop over the end of the lock pin. {see Figure 1.A}

Rear Wheel Assembly - {Figure 1.b}

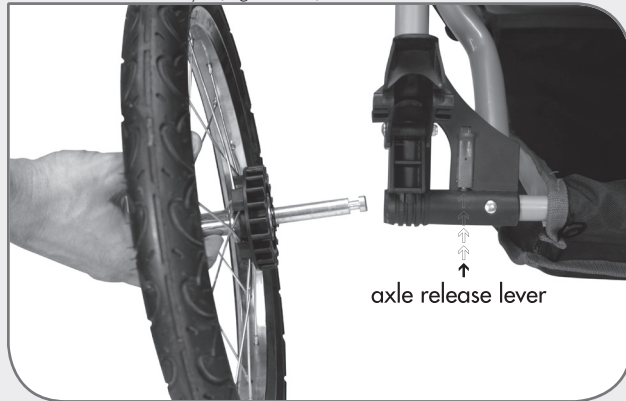

### Rear Wheel Assembly

Grasp rear wheel in one hand, slide wheel's axle into hole in rear of frame. Push up on the axle release lever so that the wheel is fully inserted. Pull the wheel firmly, the wheel should not come off if fully inserted/locked. Repeat for other side. To release wheel push up on axle release lever and pull off wheel.

### Front Wheel Assembly

Tip stroller back so that the handlebar is down on the ground and the front fork is up. Attach the front wheel by loosening the wheel's Quick Release (Q/R) lever on the front wheel far enough to allow the axle to slide into the front fork. With wheel's Q/R lever in open position, hand tighten the cone nut until almost tight, then flip wheel's Q/R lever backward to the closed position to lock wheel in place. Note this step may require minor adjustment until the Q/R lever flips back with firm pressure. Pull outward on wheel to ensure it is locked in place.

Front Wheel Assembly

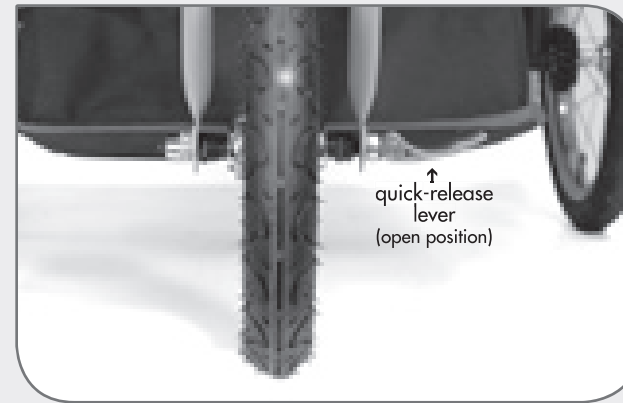

**Caution:** The interior jam nuts are factory installed and do not need adjustment.

Close the front caliper brake by lowering the Q/R lever. Spin the front wheel to make sure the brake pads do not rub and are properly aligned to the rim. If brake pad alignment is off, loosen brake pad nut with an adjustable wrench, align brake pad and retighten nut while holding brake pad in place.

**Caution:** Always be sure to reengage the brake by rotating the Q/R lever forward (toward the front wheel) before using the stroller.

### IMPORTANT

If you notice that the stroller steers to one direction you may need to adjust the front wheel to align it. To do so loosen the front axle Q/R lever, points the front wheel in the opposite direction the stroller is veering, and retighten the Q/R lever. If you need help making this adjustment, please call our Customer Service department for assistance.



### Front Fender Assembly

Insert the #8 – 1.5" screws into the holes located on the front support above the wheel. Align the holes on the bottom side of the fender with the screws and tighten with a Phillips screwdriver.

### Parent Console Attachment (not included with KS107)

The parent console will attach to the handle by snapping it in place on the handle and above the canopy.

### Tether/Wrist Strap Attachment

The wrist strap has different sized loops. The large loop will go on your wrist; the small loop will be on handlebar. Slide end with large loop through the small loop, then grasp the end with the large loop and pull strap to tighten on handlebar.

**Caution:** Whenever child is in stroller always use the wrist strap. Before you remove the wrist strap from your wrist make sure you first engage the rear brakes.

### To Engage Rear Brakes

Step on the levers next to the rear wheels until the cogs of the brakes engage the cogs of the wheel. Repeat on other side. To release brake, lift levers using your toe until cogs disengage.

### To Operate Front Caliper Brake:

The front brake operates the same as a bicycle hand brake. Squeeze lever located on handlebar to engage front brake. Release lever to disengage.

### PROPER USE OF SEAT BELTS & SHOULDER STRAPS

**WARNING:** Avoid serious injury from falling or sliding out. Always use seatbelt.

Place child in seat. Make sure T-shield is between the child's legs.

When child is seated, place shoulder straps over the child's shoulders.

Slide waist straps through lower loops of shoulder straps, bring lap belt ends together and clip into place around child's waist. Adjust waist and shoulder straps for snug fit.

### To recline seat

To fully recline, unhook buckle on back of the seat. To adjust the recline position; adjust the slide on the strap to the desired length.

**WARNING:** Child may slip into leg openings and strangle. Never use in a reclined carriage position unless T-shield and shoulder strap have been readjusted to the new seat position.

### Storage and folding

**WARNING:** Always remove child from stroller before folding

Pull the back of the seats forward. It will be easier to fold if the seats are not in the recline position. Remove locking pins from side latches on the stroller frame (Double Models have 2 locking pins). Release the two latches from the frame. The stroller may automatically begin to fold, the front wheel will fold under frame and the handle will fold backwards. For a more compact fold remove front and rear wheels

Storage and folding





## CARE AND MAINTENANCE

Check fasteners after one hour of use; check all fasteners to make sure they are secure. Adjust if necessary. Periodically check the stroller to ensure that it is in good operating condition.

To adjust the stroller from pulling to the left or right (not rolling straight): Loosen the front Q/R axle and point the front wheel in the opposite direction the stroller is pulling, then tighten Q/R lever.

***NOTE:** Sometimes it is a very slight adjustment to eliminate the pulling and this step may need to be repeated.*

**To adjust front brake caliper:** If front caliper requires additional adjustment to engage brake pads; first open Q/R brake lever, loosen the cable adjustment nut, squeeze the brake pads together and while holding brake pads retighten cable adjustment nut. Then close Q/R lever and check adjustment by squeezing hand brake lever.

For micro adjustment, turn the front brake caliper's adjusting sleeve counterclockwise. Once the brake pads are adjusted to the desired distance from the rim, tighten the lock ring. You will need to adjust the cable periodically since it is normal for the cable to stretch from use.

**To clean seat and canopy:** If light cleaning is required, use a soft cloth with warm water and mild soap then air dry. Do not put in washing machine. Do not put in dryer. **DO NOT BLEACH.**

To clean frame: Wipe using a soft cloth with warm water and mild soap. Air dry. **DO NOT USE** polish or abrasives.

**WARNING:** If you have any questions concerning the safe use of this product, please contact Pacific Cycle before using:

1.800.242.6110

8am-5pm CST, Monday-Friday, or MAIL to:

Pacific Cycle Inc.  
4730 East Radio Tower Lane  
Olney IL 62450

Tel: 1.800.242.6110  
or visit us at [www.instep.net](http://www.instep.net)  
E-mail: [info@instep.net](mailto:info@instep.net)

## ONE YEAR LIMITED WARRANTY

Pacific Cycle warrants this product to be free of defective materials and workmanship for 1 year from the date of original purchase.

**THIS LIMITED WARRANTY IS THE ONLY WARRANTY APPLICABLE TO THIS PRODUCT, AND IS EXPRESSLY IN LIEU OF ANY OTHER WARRANTY. ANY IMPLIED WARRANTIES, INCLUDING ANY WARRANTY OF MERCHANTABILITY AND WARRANTY OF FITNESS FOR A PARTICULAR PURPOSE IS LIMITED IN DURATION TO THE DURATION OF THIS EXPRESS WARRANTY. This limited warranty gives you specific legal rights and you may also have other rights which may vary from state to state.**

This warranty is extended only to the original consumer purchaser for non-commercial use and does not cover fires or tubes, grips, brake shoes, or other wear part, ordinary wear and tear, abuse, misuse, neglect, theft, or damage due to accident.

**PACIFIC CYCLE, INC., IS NOT RESPONSIBLE FOR INCIDENTAL OR CONSEQUENTIAL DAMAGES. THIS LIMITED WARRANTY DOES NOT COVER ANY PERSONAL INJURIES, DAMAGE TO, OR, FAILURE OF THE PRODUCT OR ANY OTHER LOSSES DUE TO ACCIDENT, ABUSE, MISUSE, ALTERATION, NEGLIGENCE, NORMAL WEAR AND TEAR, IMPROPER ASSEMBLY, IMPROPER FIT, IMPROPER MAINTENANCE OR USE OF UNAUTHORIZED REPLACEMENT PARTS NOT DESIGNED FOR THE PRODUCT.**

To make claim under warranty, notification of such defect must be given to Pacific Cycle, Inc at the address stated below. You will be instructed on how the product or part needing replacement should be shipped postpaid to Pacific Cycle, Inc.