

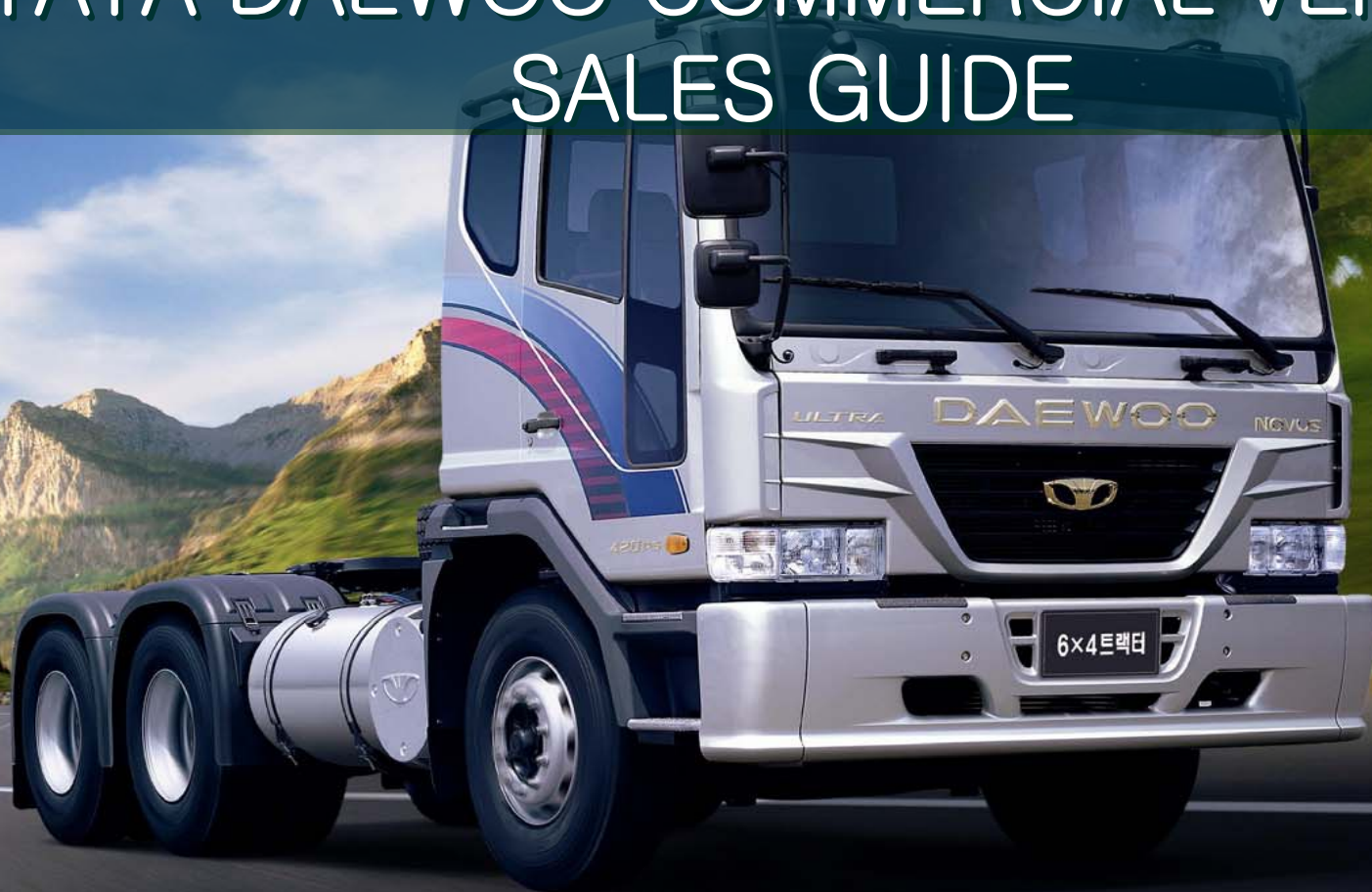

TATA DAEWOO COMMERCIAL VEHICLE SALES GUIDE



TATA DAEWOO TRUCKS - Character and Merit

SAFETY

RELIABILITY

COMFORT

MAINTENANCE



SAFETY - The High on Agenda



- ➔ Extra-large Bumper
- ➔ Safety Cab ECE-29 certificated
 - : Front Impact, Roof Crush, Rear-wall Strength
- ➔ Brake system with dual circuit
- ➔ Air dryer removing moisture and dust

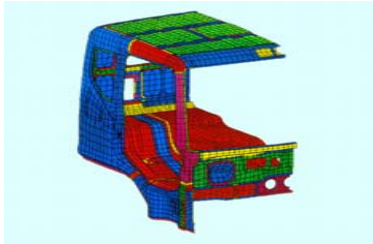

Safety cab design

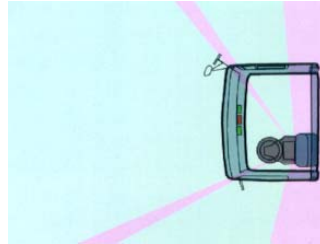

Wide range of visibility



Air dryer keeps brake line clean



Safety window on door



Seat belt tension reducer
-Optional

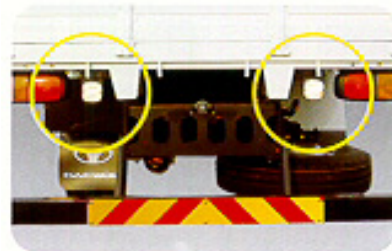

Twin back up lamp
-Optional



Air horn-Optional



Back alarm buzzer-Optional

RELIABILITY - From the Quality and Durability

➔ Quality

- ISO 9001, Quality Management System Certification

➔ Durability

- Frame : 1,000,000 km
- Engine : 1,500,000 km
- Electro Deposition Coating
 - Body In White, Frame
 - Bracket for Parts Mounting



Electro deposition coating



Clearance test for rough terrain

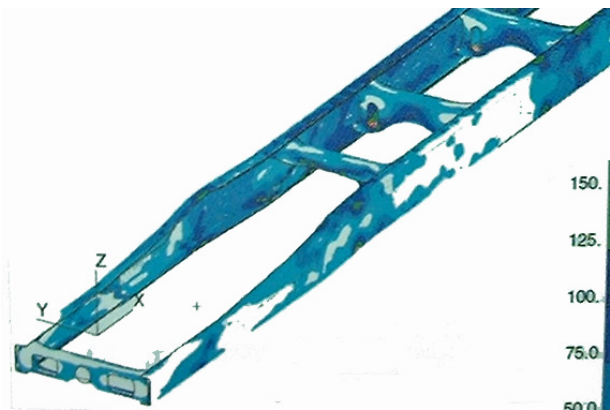

Computer based analysis & design



Water proof test

COMFORT - Together with Utility



- Spacious Interior Roominess
L x W x H(mm) : 1,500 x 2,236 x 1,649
- Cockpit type Instrument Panel
- Full Floating Cab Suspension
- Large Outside Rear View Mirror
- Large Windscreen of Good Visibility



2 tone color door trim



Multi-purpose storage space at various places



Tilt and telescopic steering



Convenient door grip

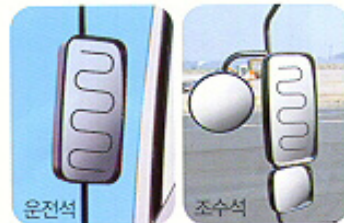

Heating side mirrors



Key hole lamp



Roomy driver space

MAINTENANCE - Quick & Simple

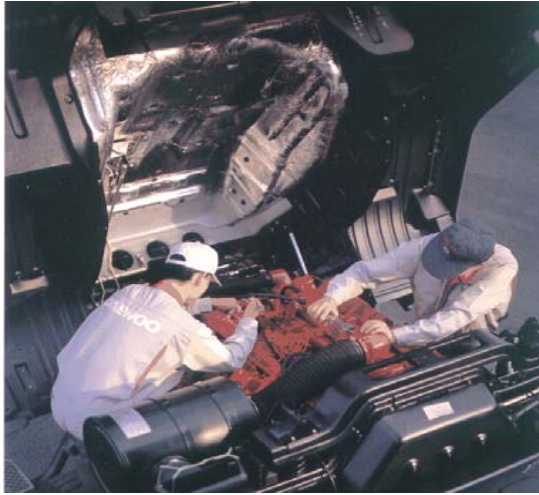

- Easy Access to Fuse Box
- Cab Tilt : up to 50 degrees
- Daily Maintenance through Front Panel
 - Washer, Engine oil, Clutch oil etc.
- Coolant Level Gauge on Surge Tank
- Extra-large Tool Box
- O.V.M. Tools including Oil Pressure Jack



Extra large tool box



Tilting angle up to 50 degrees

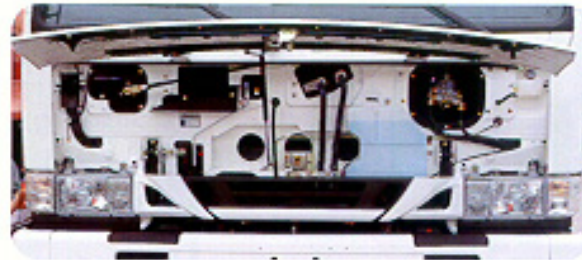

Lockable front panel for ease of maintenance



Easy Accessible Fuse box

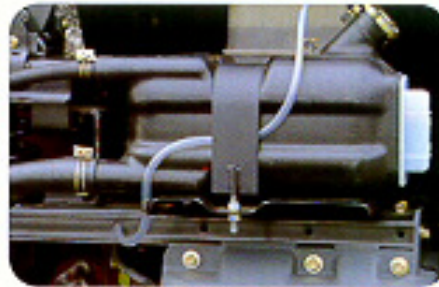

Surge tank for daily check-up

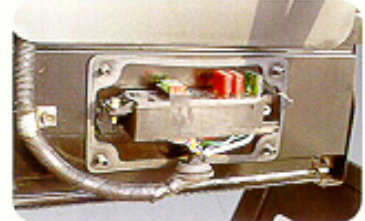

Auxiliary Fuse box

Deck & Dumping mechanism - Dump Truck



K4D6F equipped with self-opening rear gate

DECK

- Deck Volume : 10.0 m³
- Material : Steel (SS41)
- Floor thickness : 4.0 mm
- Side thickness : 4.0 mm

DUMPING MECHANISM

- Dumping mechanism : Marrel type
- Dumping angle : 53 deg.
- Dumping time : 20 sec.
- Max. Lifting capability : 20,000 kg



Strong hinge to support the load

Features - Cab Exterior

Cab Design for Extensive Driver Safety

Daewoo Cab offers the driver a safe working environment, as a result of safety oriented cab design and extensive impact tests.

Daewoo Cab complies with the European safety regulation provision of 29R, including Front Impact, Roof Crush, Rear-wall Strength. The cab is made up with pressed sheet steel panels welded together to provide reinforced structure for the driver.



Tilting Cab up to 52 degrees



Frontal Impact Test

Cab Latch System

Cab is isolated from the chassis by cab suspension and secured at the rear by locks placed on the easy side of the cab.

Release of mechanical type cab latch is done by pulling the lever while lifting the hook, locking is done by automatically when the cab is fully descend.

Hydraulic type cab latch enables the unlock by pressing the cab tilt enable switch. Unlock is done as same manner as that of mechanical type.

When ordering Cab air suspension system, hydraulic type cab latch should be selected as well.

[Standard : Mechanical type
Optional : Hydraulic type]



Hydraulic Cab Latch

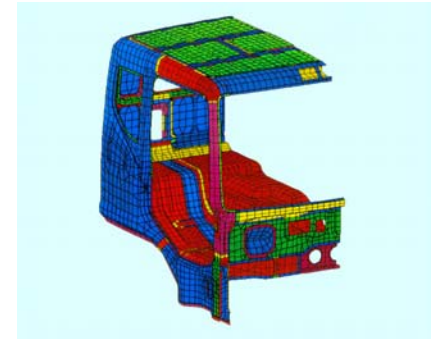

Computerized Cab Design

Cab Tilt Device

Cab tilt device opens up to 52 degree. Manual type cab tilting is offered as standard and One touch electric powered cab tilt device is optional; The cab tilt system is fitted with a operation switch on the center console which enables / disables the cab tilting.

Selecting electric-powered One touch cab is recommended in most cases for practical reason, However, in case of malfunction of system, the cab can be tilted or lowered by manual way.

Full Floating Cab Suspension

Daewoo truck features full floating 4 points cab suspension which is designed to give the driver the best riding comfort regardless of the road condition.

Cab Air suspension is perfectly mated when air suspension driver seat is chosen. It offers outstanding ride while minimizing fatigue on the long hauls.

[Standard : Coil spring and double acting shock absorber,
Optional : Air spring and double acting shock absorber]



Lockable Front Panel

Lockable Front Panel facilitates simple repairs and maintenance without having to tilting the cab.

Opening lever is next to loading grip handle and operated by pulling up. The level of engine oil, Clutch fluid, engine oil filter and wind shield washer can be checked from inside the front lid.



Lockable Front Panel

Rear view Mirror

Standard mirror type is equipped with electric defroster to ensure the perfect view irrespective of the weather condition. 2 additional convex lens mirror are helpful to get the best views near the truck.

For the models which are based on the 'basic trim'. One mirror is attached on the each side of the door.

Mekra™ mirror with electric adjustment function is available as an option. The view angle can be adjusted by control pad on the door trim.

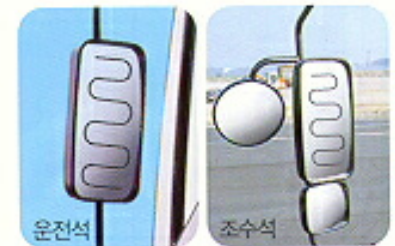

Mirror with Defroster-Standard Trim



Basic type Mirror – for Basic Trim

Features - Cab Interior

Everything at one glance, Not a split-second missed

The cockpit-style instrument panel features the newest one-touch switchgear, power steering and power gear shift to deliver passenger car-like comfort and convenience.



The cab interior is very well designed to provide the driver and passenger the best working space for every type of haulage. This cab design can be summarized as good visibility, the modern and safe cab interior and workplace of good ergonomic features.

Modern and elegant cab interior

Daewoo cab interior gives a cozy appearance in light gray color scheme. The dashboard and other interior belongings have smooth contours and provide independent space for each of driver and passenger.

Maximum Front & Rear Vision

The Ultra-large front windscreen gives the cab a 40.5 degrees field of view. A combination of ergonomics and optical engineering were used to determine the optimal size and position of the side mirrors which offer a 34.3 degree field of vision. This wide vision enables the driver to see all around the vehicle and to have a good view of the traffic as well.

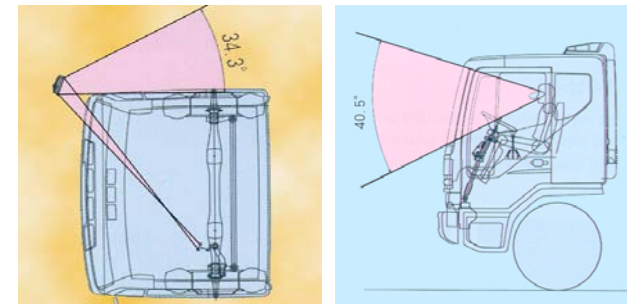

Seats

The extruded section of driver's and passenger seats gives lateral support. Standard driver seat offers height adjustment, sliding and reclining and the passenger seat is rigid type with reclining function. All seats are equipped with head rests to protect the driver and the passenger. The passenger's seat can be full folded so to provide the maximum resting space of which can be extension of bed.

* Note : The passenger's seat on R.H.D is able to be half folded.

The full air suspension driver's seat is available when better comfort is required. It can be adjusted according to the driver's height and body. It is perfectly mated to the full floating cab suspension and is designed to deliver an outstanding ride while minimizing fatigue on those long hauls. [Air suspension seat : Optional]

The arm rest is available for a more comfortable driving position in the long hours of driving. [Arm rest : Optional]

Heating mat gives quick heating function, protecting drivers from the cold before air reaches certain temperature. [Heating mat : Optional]

Seat belt tension reducer relieves the tension applied to the driver when the belt is fastened. [Seat belt tension reducer : Optional]



Driver Seat with Air Suspension and heating device



Seat belt tension reducer



Rear pocket-driver's seat

Reclining

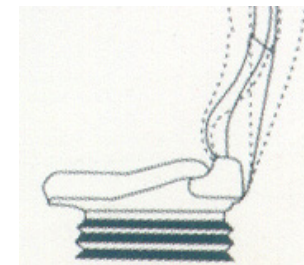

Auto leveling

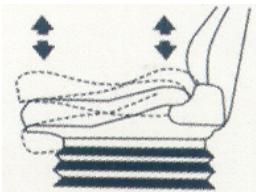

Height Adjustment

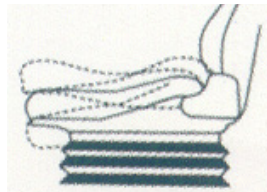

Sliding

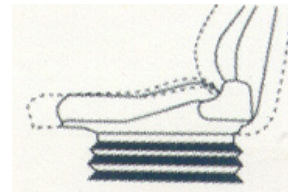

Curtain Rail

Full round type curtain rail offers total cabin privacy and comfort during rest stops

[Provided as standard without curtain]



Example : Curtain rounded driving space



Storage net between the seats



Storage net equipped console box

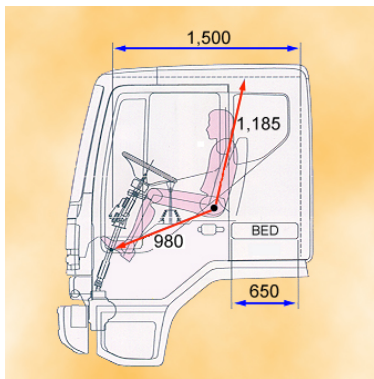

Spacious interior layout



선택옵션



조수석 글로브박스

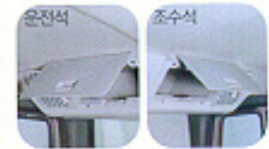

어머 콘솔박스



도어업 포켓



시트백 포켓

Various storage space

There is never a shortage of storage space; Cabin is equipped with door pockets, center console bin, glove box, two overhead stowage bin and a map pocket on the driver seat sun visor. As an option, storage net can help hold the goods or possessions when the vehicle is motion, including sudden braking, accelerating or tilting the cabin. Double layered console box cover is added with storage net for holding smaller goods. This cover fitting has a subdued color and material.

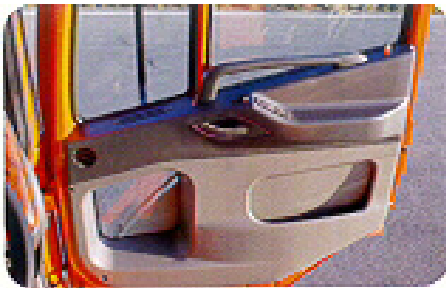

Two-tone colored door pad



Door grip – easy to operate



Safety side window

Instrument Panel

Handsomely sculpted cockpit-type instrument panel enables the driver to monitor all vehicle functions with just a quick glance. The extensive application of one touch switchgear makes the tough job of driving a sheer pleasure.

Tilt & Telescopic Steering

Tilt and telescopic features adjusting the wheel position to driver's particular liking.

Easy-to-Open Door

Hand grip helps the passenger open and close the door.

Safety Side window

The safety window port installed on the lower part of the door enables the drivers to spot trouble in the dead spot thereby providing an improved safety margin.

Air Tool Port

This makes it easier to clean the trucks. Port end are carefully selected to fit the commonly available hose in the after market.



Tilt and telescopic power steering



Air gun port

Color matched for safety

To improve the visibility and safety of the passenger, Yellow colored holding grip and switches are adopted. This is helpful especially when loading and unloading.



New Wood grain patterns

New wood grain patterns gives more harmonious impressions with well matched to the cab interior by reducing the reflections. Vent grille at center and passenger side have wood grains patterns.



Auto Door Lock

Locking the driver side door automatically locks the passenger door at the same time. [Optional; Requires one touch power window]



Auto Door lock

Extra Passenger Seat

Upon special request, extra passenger seat can be fitted on R.H.D version. Consult nearest dealer or Daewoo motor before order.



Extra passenger seat

Right Hand Driving Version

Daewoo truck offers R.H.D version. Most of the features are of the same high quality as L.H.D versions



Interior – Right Hand Driving



One touch Power window

One touch Power Window

Offers driver and passenger window control [Optional; usually comes with auto door lock]

Features - Chassis System

Air dryer

Air Dryers collect and remove air system contaminants in solid, liquid and vapor form before they enter the brake system. They provide clean, dry air to reservoirs, valves and other components, increasing the life of the system, reducing maintenance costs and preventing air line freeze ups.

(Standard equipment)

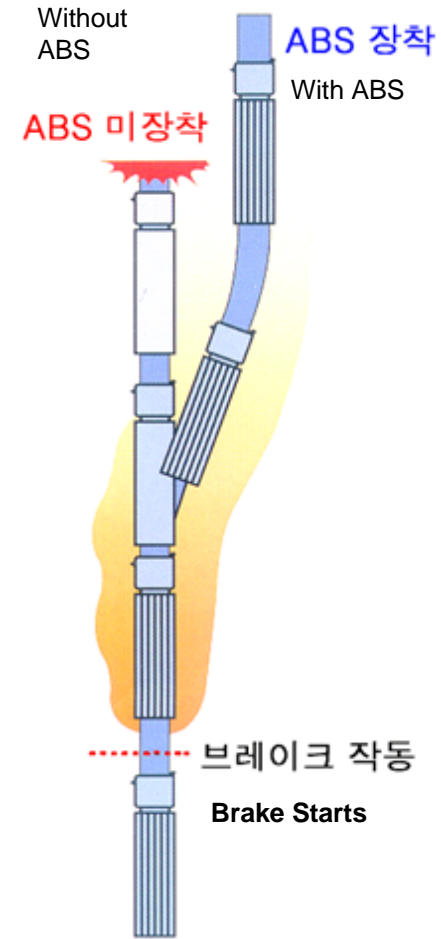

Dual circuit Brake system

To prevent from unexpected accident on driving every truck should equip dual brake circuit which gives safer braking condition with separate brake line ,air tank and brake valves

ABS/ASR

(Anti-Lock Brake System/
Anti-Slip Regulator)

Stopping a car in a hurry on a slippery road can be very challenging. Anti-lock braking systems (ABS) take a lot of the challenge out of this sometimes nerve-racking event. In fact, on slippery surfaces, even professional drivers can't stop as quickly without ABS as an average driver can with ABS.

The theory behind anti-lock brakes is simple. A **skidding wheel** (where the tire contact patch is sliding relative to the road) has less **traction** than a non-skidding wheel. If you have been stuck on ice, you know that if your wheels are spinning you have no traction. This is because the contact patch is sliding relative to the ice. By keeping the wheels from skidding while you slow down, anti-lock brakes benefit you in two ways: You'll stop faster, and you'll be able to steer while you stop.

(Standard equipment in Domestic Model, Optional in Export Model)



Silver color Air tank

Silver colored air tank enhances rust proof and its color is well matched with aluminum fuel tank and silencer (Standard equipment)



Automatic Slack Adjuster

Main function of Automatic slack adjuster is to adjust lining wear automatically as it says

This monitors brake lining to brake drum clearance, thus eliminating the possibility of over adjustment

The entire slack adjuster operates as a unit, rotating as a lever with the brake cam shaft as the brake are applied or released. The most efficient braking action is obtained when the slack adjuster arm travel is minimal, therefore, it is important that brake adjustment are made as often as necessary.

The automatic slack adjuster does not require periodic manual adjustment, however, the unit does provide manual adjustment. (Optional equipment)

Automatic adjuster For Clutch Booster

To adjust clutch clearance Automatically (Optional equipment)



Aluminum Fuel tank

Aluminum fuel tank has better structural characteristics due to its circular shape and improves appearance of the truck

.(Standard in Domestic Model
Optional in Export Model)

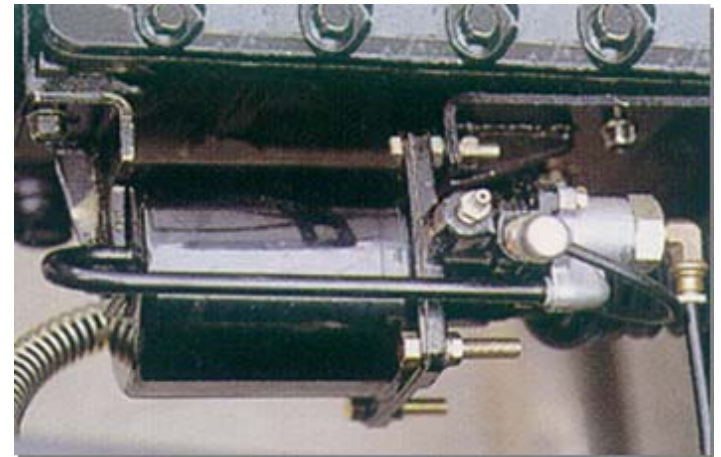

Vehicle Delivery Guide

Before being delivered to the customers

Every Daewoo truck is produced and inspected as specified in the quality control policies which comply with the ISO9001, widely known international standard.

Unlike the vehicles delivered locally in Korea, the trucks for overseas customers are treated by anti-corrosion wax. Anti corrosion wax can be removed by using wax cleaner which is supplied with the trucks when delivered.

On Vehicle Maintenance Tools

Every truck is to be provided with the service publications and standard tool set for basic daily vehicle maintenance. These include,

- 15ton Oil Jack (4x2)
- 22ton Oil Jack (6x4 or higher)
- Handle – spare tire
- Lever – cab tilting
- Wrenches
- Screw driver
- Spanner & Plier
- Tool bag

The specific details and the number of the tools are variable in accordance with the type of the trucks.

Keys

Total of 4 keys are supplied with the new truck. 2 are ignition keys and the other 2 are tool box lock keys.

The owner of truck is highly recommended to keep spare keys in a safe place for the case of missing.

The O.V.M tools are usually stored in the tool box located at the chassis frame. Tool box is locked before the trucks leaves factory. These keys are provided with the ignition keys.



Example of the standard tool set



2 Ignition keys and tool box lock keys

Cab Chassis Delivery

There are two major conditions for delivering cab chassis.

As a standard condition, the truck is delivered without the parts which are usually mounted on the superstructure body.

Such parts include side and rear protectors and their belongings, spare tire carrier, rear lamp mounting brackets.

Spare tire is usually mounted on chassis frame with a carrier. But for the those of which are based on dump trucks, spare tire is mounted on the frame without a carrier.

For the customers those who require such extra accessories, Daewoo provides side and rear protector, wheel mud guard as an option based on firm order. They are supplied with the truck in disassembled condition.



Optional wheel mud guard and rear protector



Standard Cab chassis condition – Rear View



Optional side protector in disassembled

Service Publications

Service Manual and parts catalogue

Basically, service manuals and parts catalogue are prepared for a training and service at a workshop of a distributor. Additional copies are supplied based on the customer's firm order.

Owner's Manual and service guide

Each new truck is supplied with the owner's manual and service guide prepared primarily for the vehicle owner or a driver. They should be kept in the truck for quick reference during the daily operation.

Number of books provided are listed as below.

- Owner's manual & service guide : 1 ea / per each unit
- Parts catalogue (Chassis, engine, electrical) : 1 set / 10 units
- Service manual (Chassis, engine, powertrain) : 1 set / 10 units

Additional copies of books are available upon request and these request are regarded as a parts order.



Parts Catalogue, Service manual, Owners manual, Service guide



Example of the service publications stored in the passenger seat space