

X One® Tire Maintenance

X ONE® TIRE — MOUNTING	24-26
Mounting Setup, Wheel Preparation, Inspecting for Damages, Lubricating the Tire and Wheel, Mounting the X One Tire	
X ONE® TIRE — DEMOUNTING	27-29
2-Bar Demount Method, 3-Bar Demount Method, Demounting the Second Bead	
MISMOUNT	30-31
3 Easy Steps to Help Minimize Mismounted Tires	
TIME STUDY — X ONE® TIRE VS DUAL	32-33
Demounting the X One Tires vs Dual, Mounting the X One Tires vs Dual, Torque	
AIR INFILTRATION	34-35
AIR PRESSURE	36-38
HOW TO PROPERLY MEASURE PRESSURE	39-44
Temperature/Pressure Relationship Chart, The Use of Nitrogen in Michelin Truck Tires, Runflat and Zipper Ruptures, Tire Inspection, X One® Tires Load and Inflation Tables	
IRREGULAR TIRE WEAR	45-46
Tractor: Heel-Toe/Block-Edge Wear, Center Wear, River Wear Only Trailer: Step-Shoulder/Localized Wear, Shoulder Cupping, Brake Skid	
ALIGNMENT AND VIBRATION	47-49
Introduction, Axle Skew, Trailer Alignment, Vibration, Runout and Balance	
TREAD DEPTH PULL POINTS	50
CARE, CLEANING AND STORAGE	51
SEALANTS	52
VALVE STEM INSPECTION	52



X ONE® TIRE — MOUNTING

X One® tires are easily mounted on 14.00 X 22.5" approved wheels using procedures similar to that of Dual. Correct steps and safety practices should be followed to help ensure a proper mount of the tire and wheel assembly. These points are covered in the Michelin Truck Tire Service Manual (MWL40732).

MOUNTING SETUP

Be sure to use tools in good condition, along with approved vegetable-based lubricants, with the proper ratio of lubricant-to-water. **NO** petroleum oils/grease, silicone oils or solvent-based lubricants should be used, as these can swell and damage rubber. The lubricant and brushes should be free of contaminants. In addition make sure to use all personal protective equipment like safety glasses, steel toe boots, and gloves when mounting assemblies.

Mounting tools can include traditional T-45 irons, wide base Golden tool, and approved mounting machines.

Ensure a good area is available to perform your tire work. Floor mats or pads would be beneficial. Make certain all components (the tire, wheel, and valve) are identified as correct for the assembly. Inspect each component for any damages and/or conditions that would render it unserviceable, and replace item if necessary.



Mounting tools



Work area

WHEEL PREPARATION

Make sure the wheel is clean of rust and debris, and the mounting surface is smooth. Damaged and leaky valve stems, O-rings and grommets must be replaced. You should include in your tire mounting procedures replacing the valve with a new one for every mount to safeguard against any possible used valve/O ring issues. Ensure the valve stem is installed using the proper torque value: 80-125 in/lbs (7-11 ft/lbs) for aluminum wheels, and 35-55 in/lbs (3-5 ft/lbs) for tubeless steel wheels.



INSPECTING FOR DAMAGES

A safety reminder prior to mounting a new tire: check for any signs of damage from shipping or storage to the sidewalls, inner liner, or beads. For a used/repaired/retreaded tire, check for signs of low inflation pressure or runflat conditions on the inner liner (marbling, wrinkles, and discoloration).

Also, inspect the bead areas for damage, and if a repair(s) is noted, inspect to make sure it's in good condition. If the tire is deemed ready for service, lubricate both beads of the tire and the wheel.



Runflat wrinkling



Runflat ring in flex zone

LUBRICATING THE TIRE AND WHEEL

When applying lubricant to the wheel, lubricate the entire wheel surface from flange to flange. Apply a liberal amount - lubricating both components will assist in the ease of the mount and will ensure proper seating of the beads on the wheel.



Lubricating the tire



Lubricating the wheel

MOUNTING THE X ONE® TIRE

The tire should be mounted and inflated before the lubricant dries.

With the wheel short side up (narrow side), lay the tire over the wheel at the valve side and work it on with proper tubeless tire tools, making full use of the drop center well (when using a T-45 iron – use the curved end with a ledge).



Padded bead keepers can be useful during the mounting process by keeping the bead fixed on the flange, thus avoiding the need to keep a foot in place.

Using same iron and method, mount the second bead. When mounting the second bead, keep one foot in place to keep the bead seated, and move the other foot around the tire as each part of the bead is seated to keep it in place.



Lay the tire/wheel assembly horizontally and inflate to no more than 5 psi to correctly position the beads on the flanges.



Place the assembly in a safety cage (per OSHA standards) and continue airing to 20 psi. An extra wide safety cage is available for safe inflation of the tire. In most cases, a standard cage can accommodate the X One assembly. Check the assembly carefully for any signs of distortion or irregularities from run-flat. Closely inspect the sidewalls for bulges/pulled cables that would indicate the tire ran underinflated. You should also listen for signs of deterioration in the casing cables (i.e., crackling sound).



If run-flat is detected, scrap the tire. If no damage is detected, continue to inflate to the manufacturer's recommended operating pressure as listed in the load and inflation tables.

Please note the lower sidewall "beauty rings", and ensure the ring is positioned concentrically in relation to the rim flange with no greater than 2/32" of difference found circumferentially. If the bead(s) did not seat, deflate tire, relubricate the beads and wheel flanges and re-inflate.



Finally, give the valve stem a check for leakage or air loss with a squirt of leak finder (soap and water). If no leak is found, seal with a metal valve cap.



X ONE® TIRE — DEMOUNTING

All tires must be completely deflated prior to loosening any nuts and demounting from the vehicle.

Deflate the tire by removing the valve core. Check the valve stem opening with a wire to make sure it is not plugged.



With the tire assembly lying flat, break the bead seat of both beads with a bead breaking tool.



Apply the lubricant to all surfaces of the bead area on both sides of the tire. Make certain that the flange with the tapered ledge that has the shortest span to the drop center is facing up.



WARNING

DO NOT USE HAMMERS of any type. Striking a wheel/rim assembly with a hammer can damage both the tire and the wheel and is a direct OSHA violation.



2-BAR DEMOUNT METHOD

Beginning at the valve, remove the first bead using the curved end of the tire irons. Place the two irons 6-8" apart and "walk" through towards the center of the assembly, placing both irons on the opposite flange. This will lift the first bead up over the flange.

Remove one of the irons, and continue to work it around the tire bead taking small "bites" until the entire bead is removed.



3-BAR DEMOUNT METHOD

This method is similar to the 2 bar method with a third iron inserted 8" from the first two. With the first two irons, "walk" through towards the center of the assembly, placing both irons on the opposite flange. This will lift the first bead up over the flange. Leave both irons in this position. With the third iron, "walk" through towards the center of the assembly. This should remove the first bead from the wheel. Remove the third bar and take additional "bites" if necessary to fully remove the first bead from the wheel.

Make sure to have adequate lubrication, and use the irons correctly to eliminate tire and/or wheel damage.



DEMOUNTING THE SECOND BEAD

Now demount the second bead. There are two methods to accomplish this task.

FIRST METHOD

The first method is to position the tire/wheel assembly upwards, with the short side at twelve o'clock. Place smooth/flat end of two irons under the tire bead, and turn the irons to lock the lip against the flange of the wheel. Carefully lower assembly, using an up and down rocking motion, and the tire will release from the wheel.



SECOND METHOD

The second method for demounting the second bead is to lay the tire flat on the ground, with the tire irons under the flange of the wheel, and with a rocking motion, disengage the wheel from the tire. Some technicians find this method to be easier.



The methods described are the most common way of mounting and demounting X One® tires using standard tire irons. There is a variety of other hand tools and automated machines available through tire supply stores that accommodate X One® tire products.

MISMOUNT

Mismount occurs when the tire beads do not seat fully on the tapered rim flange area of the wheel. As can be seen in this diagram, one of the tire beads has fully seated against the rim flange. But in another small area the bead did not “climb” completely up the tapered area of the wheel. In this area the bead is tucked further under the rim making the sidewall slightly shorter. If the tire continues to run, it will develop “maxi-mini” wear, which is characterized by the tread depth on one side of the tire being deeper than on the other side. In this case, balancing will only be a “band-aid.” In other words, the tire may be balanced for a few thousand miles, but as the tire wears, the weights would have to magically shift to another part of the tire/wheel assembly. Because they don’t magically shift to other locations, the driver usually comes back after a few thousand miles saying “whatever you did, it worked for a little while, but now the vibration has come back.”

If the tire mismount is not detected immediately, the tire may develop localized shoulder wear. Eventually the tire wear pattern will appear around the rest of the shoulder, sometimes resulting in a noticeable ride disturbance.

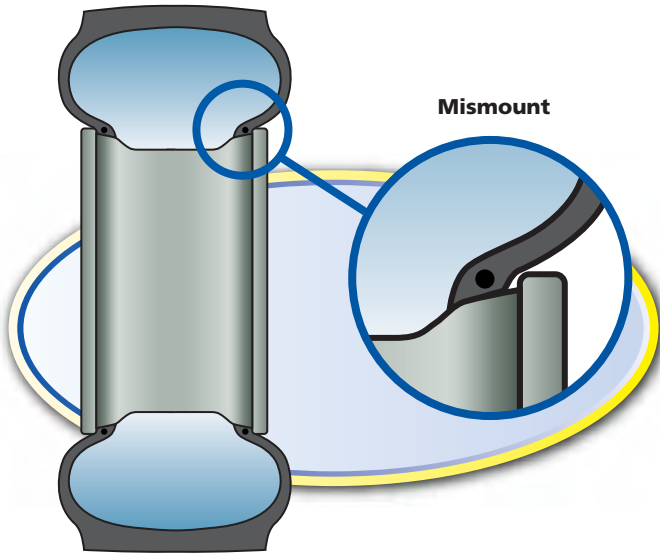

If mismount is detected early: deflate, dismount, inspect, re-lube and re-mount the tire. Sometimes the irregular wear from mismount may be too significant to fix. At this point you can either send the tire to the trailer position or retread the casing.

For a detailed discussion on mismount please refer to the Runout and Match Mounting video from your Michelin Representative.

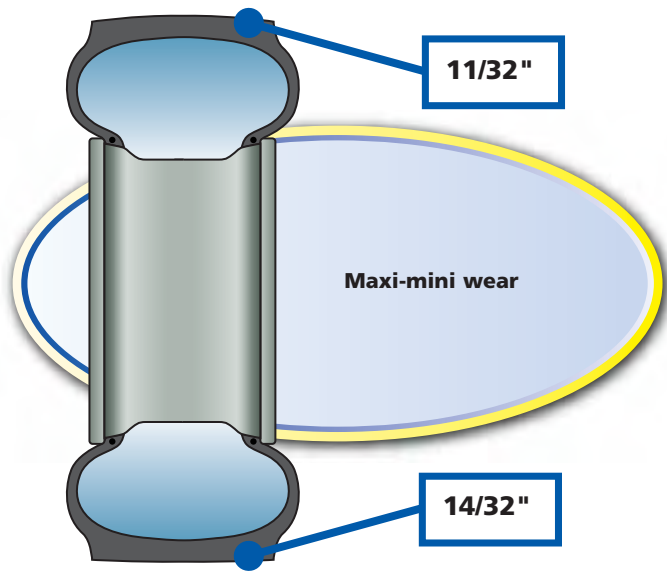

THERE ARE 3 EASY STEPS TO HELP MINIMIZE MISMOUNTED TIRES:

1. Use a generous amount of tire lube.

Make sure that you only dilute the lube to the specifications of the manufacturer. Some shops will try to dilute the lube additionally to save money. This is a bad idea, because the dollar or two you save on a bucket of lube will be hard to make up the first time you have to remove a tire early from service from mismatching irregular wear or for damaged beads.

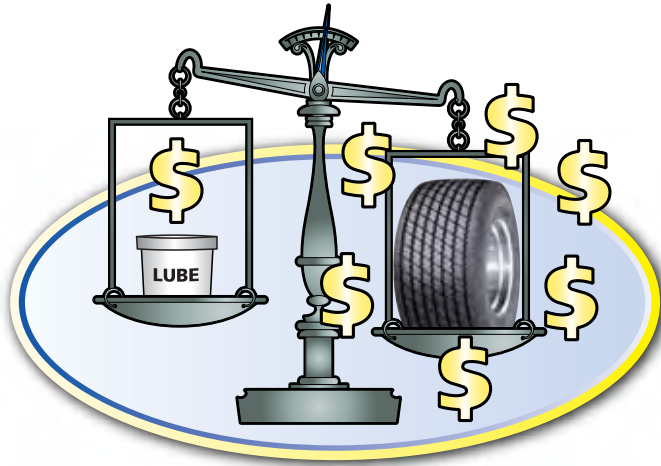

2. Inflate the assembly enough to seat the beads with the tire laying horizontally or parallel to the ground.

A good practice to follow that will ensure the tire beads are seated properly is to lay the tire and wheel horizontally on the ground, or better yet, use a 5 gallon bucket as a stand, which will keep the bottom sidewall



Five gallon bucket filled with weights.

from touching the ground. The reason you want to seat the beads with the tire horizontal is that if the initial inflation is done with the tire and wheel standing vertically, the weight of the wheel pushing down on the two beads must be overcome in order to center the wheel on the tire. An X One® tire wheel weighs between 70 and 125 lbs. and it can be very hard to overcome gravity if tire beads are seated with the tire/wheel inflated standing up. OSHA guidelines require the tire to be inflated in an approved safety cage. However, the first 3 to 5 psi of air pressure may be applied to the tire outside the safety cage to properly seat the beads.

3. Inspect the guide rib to ensure that the tire is concentrically mounted.

Using a small machinist's ruler (available at most hardware stores for ~\$2) check the wheel flange to guide rib on your inflated tire. The maximum variation allowed is $\frac{1}{32}$ ". You should check the wheel flange to guide rib at four locations: 12:00, 3:00, 6:00 and 9:00.



TIME STUDY – X ONE® TIRE VS DUAL

DEMOUNTING X ONE® TIRE

- One tire and wheel: deflating, demounting, re-mounting, and re-inflating.
- Average time for one assembly is around 13-14 minutes.



Lubricating beads for dismount



Demounting X One® Tire



Re-mounting X One® Tire



Re-inflating X One® Tire

DEMOUNTING DUAL

- Two tires and wheels: deflating, demounting, re-mounting, and re-inflating.
- One air line.
- Average time is around 18 – 19 minutes.



Demounting dual



Re-mounting dual

Having a second air line will cut down the time by about one third. With multiple air lines, the time is similar to X One® tire.

MOUNTING ON VEHICLE – X ONE® TIRE



Mounting X One® Tire on the vehicle

HUB PILOTED SINGLE

One assembly
10 flange nuts (Either side)

STUD PILOTED SINGLE

Two assemblies
10 Cap nuts (Left side)
10 Cap nuts (Right side)

(22 Parts)

MOUNTING ON VEHICLE – DUAL



Mounting dual on the vehicle

HUB PILOTED DUAL

Two assemblies
10 flange nuts (Either side)

STUD PILOTED DUAL

Four assemblies
10 inner cap nuts (Left side)
10 inner cap nuts (Right side)
10 outer cap nuts (Left side)
10 outer cap nuts (Right side)

(44 Parts)

In addition, dual wheels must be clocked for valve stem access through the hand holes.

Mounting on hub-centered axles for the X One® tire or Dual should take ~ 2 minutes for each axle end. While mounting Dual on axles with stud-centered hubs, additional time is required due to the installation of an inner and outer nut for each stud, and having to line up hand holes.

TORQUE

Once the tire/wheel assembly is mounted onto the axle end using an air gun, the final torque of each wheel nut must be applied using a calibrated torque wrench to 450-500-foot pounds. This will only take a minute to perform, and is a safety procedure that will help prevent loose and broken components, and even wheel-offs.



Torque wrench

AIR INFILTRATION

Air infiltration is an “inside-out” damage. The air inside the tire is much higher (80-120 psi) than atmospheric pressure. Modern tubeless tires have a major advantage over a tube-type tire. When a tube-type tire is punctured, it only takes seconds to become flat. A tubeless tire may take weeks or months for the air to escape – this is because the inner-liner (airtight lining) is integral to the tire. One issue with tubeless tires is that even though they may take a long time to go flat, the air is still trying to get out. As the high pressure air makes its way back through the puncture channel, it can separate products within the tire.

The cause of air infiltration can be from:

- nail or other puncture,
- objects left in the tire,
- bad repair,
- bead damage from mounting/dismounting,
- or anything that has caused the inner-liner to become damaged.

A dual tire can show this effect on the upper sidewall, bead area or between crown belts. Nine times out of ten, though, it will be in the upper sidewall, and manifest itself as a flap or “smiley face.”



A more severe form of air infiltration on dual tires results in belt separation and subsequent rapid air loss.



Just as the X One® tire reacts differently to air pressure settings, it also reacts differently to air infiltration. The usual effect of air infiltration on an X One® tire can be seen between the top or protector ply and the tread rubber. Air infiltration always results in removing the tire from service (dual or wide single), however, not having belt separation or large sidewall ruptures could prevent rapid air loss events.



AIR INFILTRATIONS ARE AVOIDABLE.

Never use a duckbill hammer to mount tubeless truck tires, as this is the number one cause of bead damages.

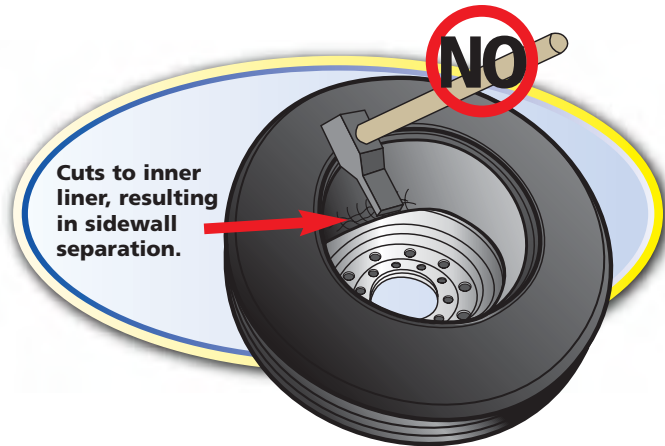

Use proper repair techniques and inspect all repairs prior to returning tire to service.



Remove and repair nails, screws and other penetrations promptly, **BEFORE** they can cause air infiltration.



NEVER leave service items inside the tire like repair parts, valves, caps, etc. **NEVER** intentionally place items like golf balls inside the tire to "act" as a balancing agent, as this can lead to inner-liner damage.



REMEMBER: Any object that cuts the inner-liner can lead to air infiltration!

AIR PRESSURE

FOOTPRINT COMPARISONS TO DUAL TIRE FITMENTS

FOOTPRINTS:
X One® XDA®
 versus
275/80R22.5 XDA2®

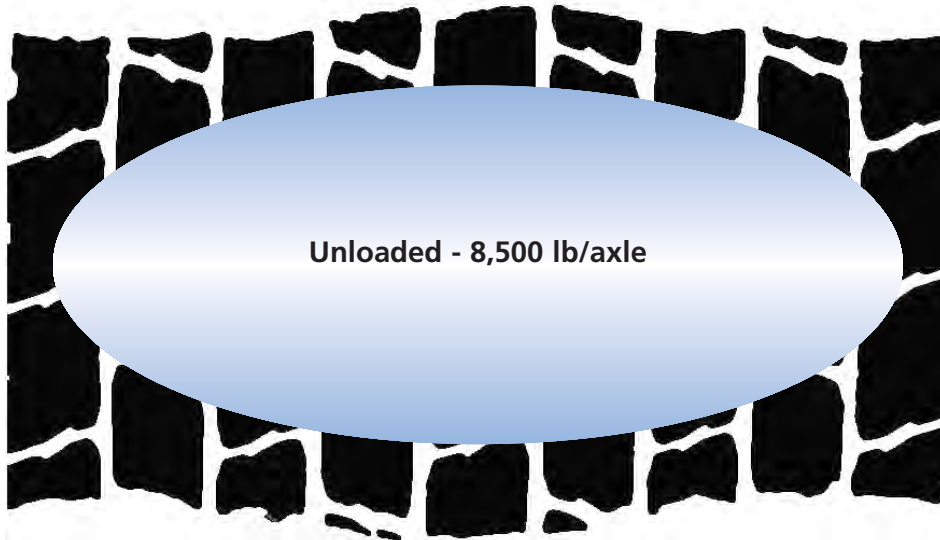

Unloaded - 8,500 lb/axle

Loaded - 17,000 lb/axle

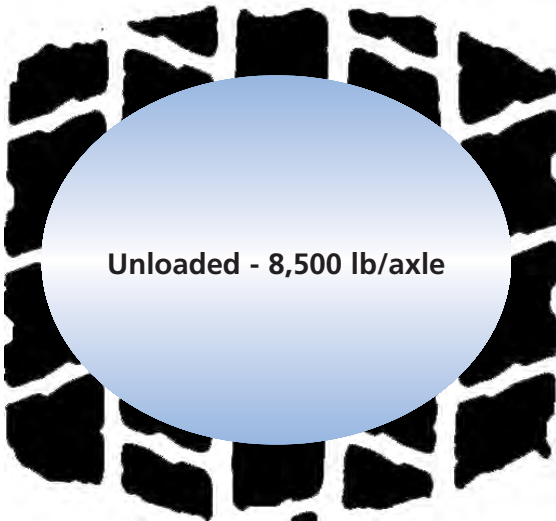

Unloaded - 8,500 lb/axle

Loaded - 17,000 lb/axle

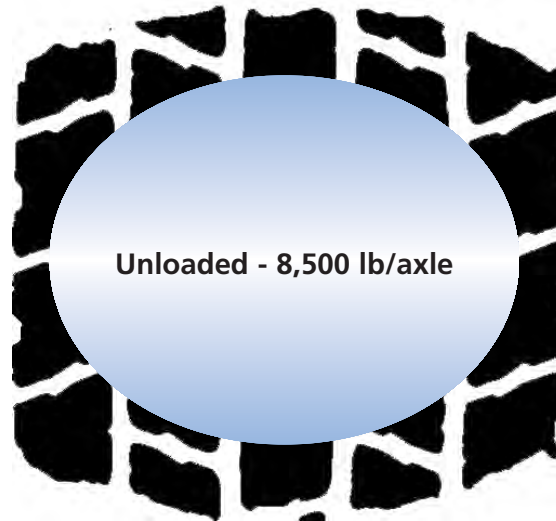

Unloaded - 8,500 lb/axle

Loaded - 17,000 lb/axle

Tire	Axle Load (lbs)	Pressure (psi)	Loaded Section Width	Footprint Length	Footprint Width	Total Footprint Area	x	Contact Surface Ratio	=	Total Contact Area	% of 2 Duals
			mm	mm	mm	sq. mm		%		sq. mm.	
445/50R22.5 X One® XDA®	17,000	105	459	201	376	69,400	x	0.686	=	47,600	0.98
275/80R22.5 XDA2®	17,000	105	297	200	216	39,450	x	0.616	=	24,300	
455/55R22.5 X One® XDA-HT™ Plus	17,000	100	472	227	385	74,350	x	0.697	=	51,800	0.95
11R22.5 XDA-HT™	17,000	100	304	204	216	41,250	x	0.674	=	27,800	
275/80R24.5 XDA-HT™	17,000	100	298	206	215	40,750	x	0.679	=	27,300	

You will notice that switching to single tire fitments causes a slight reduction in footprint area when compared to dual. This will not have a negative impact on your traction.

Your X One® tire footprint will be dependent on air pressure recommendations and vehicle loads. You should always select a pressure that will

adequately support the loads your fleet encounters as defined in the Michelin Truck Tire Data Book (MWL40731). Overinflation of your X One® tires will not only reduce your footprint but can adversely affect handling, wear, and ride characteristics. Overinflating your tires may also result in exceeding the wheel's maximum pressure.

445/50R22.5 X ONE® XDA-HT™ AT 100 PSI



120 PSI FOOTPRINT OVERLAID ON 100 PSI FOOTPRINT

The photo below demonstrates what occurs to the footprint when you over-inflate the same tire to 120 psi. The overinflated footprint's length and width are reduced (black footprint) when compared to 100 psi footprint (gray footprint).



Shoulder: -33 mm

Center: -13 mm

X ONE® TIRE AIR PRESSURE MAINTENANCE PRACTICES

Tire pressure maintenance advice for users of the Michelin® X One® wide single truck tires (445/50R22.5 LRL and 455/55R22.5 LRL)

Proper air pressure maintenance is critical to obtain optimized performance from these tires. Due to the unique casing design of the Michelin® X One® tire, traditional air pressure adjustment practices for dual tires may not apply to Michelin® X One® tires. In order to help ensure optimal performance of these tires, Michelin North America, Inc. offers the following guidelines:

- 1) Cold inflation pressure should be based on maximum axle load in daily operation. Cold inflation pressures must not be lower than indicated in the tables below for actual axle loads. For additional information please consult the Michelin Truck Tire Data Book (MWL40731).

- 2) If rapid or irregular wear develops, please refer to the chart below for diagnostic steps:

A 10 psi incremental change in tire inflation can alleviate most wear forms derived from vehicle anomalies, driver influence and/or application. Always refer to actual axle loads to determine the initial recommended cold inflation pressure.

Cold inflation pressures must not be lower than indicated in the tables above for actual axle loads.

Application	Location of Wear	Possible Cause
Trailer Tires	Shoulder	Pressure too low
	Center	Pressure too high
Drive Tires	Shoulder	Pressure too high
	Center	Pressure too low

445/45R22.5 LRL (X One® Tires)

PSI	90	95	100	105	110	115	120	125	130		MAXIMUM LOAD AND PRESSURE ON SIDEWALL	
kPa	620	660	690	720	760	790	830	860	900			
LBS	SINGLE	17440	18200	18960	19720	20400	21200	22000	22600	23400	S	10200 LBS at 120 PSI
KG	SINGLE	7860	8280	8580	8860	9260	9560	9940	10220	10600	S	4625 KG at 830 kPa

445/50R22.5 LRL (X One® Tires)

PSI	75	80	85	90	95	100	105	110	115	120	MAXIMUM LOAD AND PRESSURE ON SIDEWALL		
kPa	520	550	590	620	660	690	720	760	790	830			
LBS	SINGLE	14000	14740	15480	16200	16920	17640	18340	19020	19720	20400	S	10200 LBS at 120 PSI
KG	SINGLE	6360	6660	7040	7320	7700	7980	8260	8620	8900	9250	S	4625 KG at 830 kPa

455/55R22.5 LRL (X One® Tires)

PSI	80	85	90	95	100	105	110	115	120	125	MAXIMUM LOAD AND PRESSURE ON SIDEWALL		
kPa	550	590	620	660	690	720	760	790	830	860			
LBS	SINGLE	15400	16160	16920	17660	18400	19140	19860	20600	21200	22000	S	11000 LBS at 125 PSI
KG	SINGLE	7000	7400	7700	8100	8380	8680	9060	9340	9720	10000	S	5000 KG at 860 kPa

455/55R22.5 LRM (X One® Tires) See the chart on Page 10 for use on 13.00x22.5" wheel.

PSI	85	90	95	100	105	110	115	120	125	130	MAXIMUM LOAD AND PRESSURE ON SIDEWALL		
kPa	590	620	660	690	720	760	790	830	860	900			
LBS	SINGLE	16660	17440	18200	18960	19720	20400	21200	22000	22600	23400	S	11700 LBS at 130 PSI
KG	SINGLE	7560	7860	8280	8580	8860	9260	9560	9940	10220	10600	S	5300 KG at 900 kPa

HOW TO PROPERLY MEASURE PRESSURE

The first step in properly measuring your X One® tires is to have an accurate pressure gauge. Pressure gauges should be checked weekly against a master calibrated pressure gauge. *Tire Billy's and Thumpers are not considered accurate tire gauges!*

Sometimes, reading the gauge can present difficulties if personnel are not properly trained. Spend the time to explain to your personnel the increments on the gauge and how to properly read pressure. It is highly recommended that you use a real tire and let the trainee take the pressure and tell you what it reads.

Proper air pressure maintenance is critical to obtain optimized performance from your X One®

tires. As part of your pre-trip inspection, it is recommended that you check your X One® tires daily with an accurate tire pressure gauge.

Check all tires when cold; at least 3 hours after the vehicle has stopped. Never bleed air from hot tires.

Underinflation can lead to:

- Adverse handling conditions
- Zipper ruptures
- Casing fatigue and degeneration
- Irregular wear
- Decreased tread life

Overinflation can lead to:

- Adverse handling conditions
- Reduced resistance to impacts and penetrations
- Increased stopping distances
- Irregular wear
- Decreased tread life



THE USE OF NITROGEN IN MICHELIN® TRUCK TIRES

Nitrogen is an inert gas and will not adversely affect the inner-liner of the tires nor will it adversely affect the performance of the tires under normal operating conditions.

Therefore, the use of nitrogen in Michelin® Truck Tires will not affect the warranty associated with the tires.

Please refer to the Michelin Truck Tire Warranty Manual (MWE40021) for what is and is not covered by the warranty.

TEMPERATURE/PRESSURE RELATIONSHIP GRAPH

This graph displays the reason behind checking your tires when cold. As ambient temperature increases, pressure increases. An increase in ambient and /or operating temperature will result in an increase in tire pressure. Checking your tires when hot will result in an elevated reading. A good field thumb-rule to use is that for every 10-degree F increase in temperature above 65, the tire's pressure will increase 2 psi.

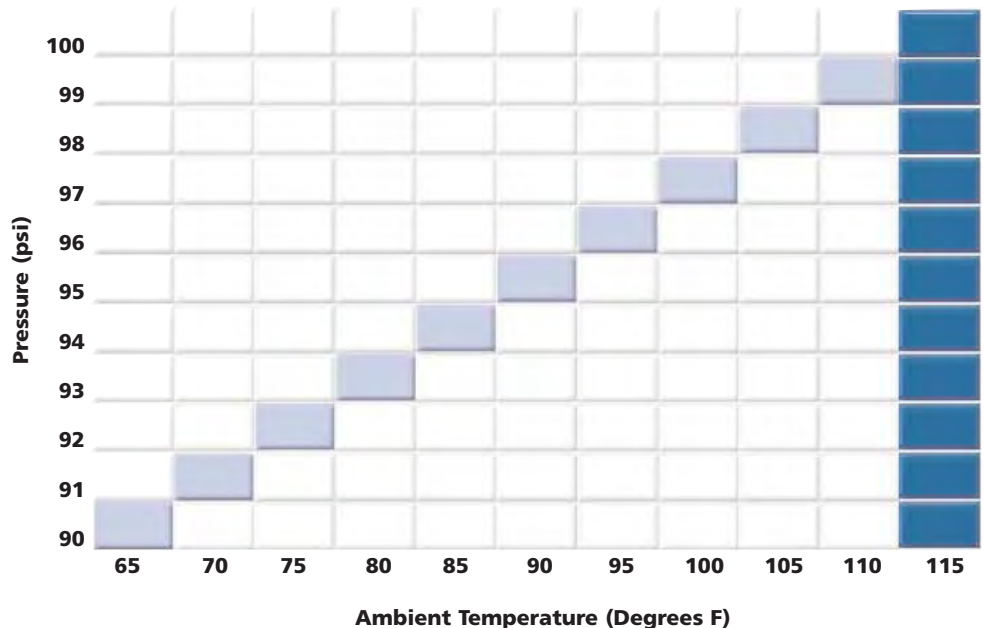

RUNFLAT AND ZIPPER RUPTURES

Runflat: Any tire that is known or suspected to have run at 80% or less of normal operating pressure.

Normal Operating Pressure: The cold inflation pressure required to support a given load as recommended by the tire manufacturer's data book.

Zipper Rupture: This condition is a circumferential rupture in the flex zone of the sidewall. This damage is associated with underinflation and/or overloading. Any moisture that is permitted to reach ply cords will cause corrosion which can also result in a Zipper Rupture.



Circumferential rupture of casing ply or "Zipper Rupture"

Occasionally, a tire will be flat when it arrives at the repair facility and there will be no external signs of a rupture. Note the X-ray photo below on the right reveals the broken casing ply cords. If re-inflated, this tire will experience a rapid loss of air with explosive force. **Zipper ruptures can and have resulted in serious injuries and death!**



X-ray photo of broken cords on unruptured casing

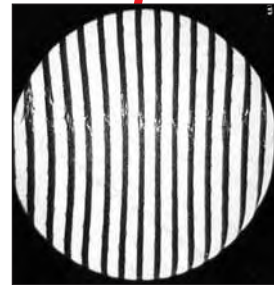

You should always use an accurate pressure gauge to determine the pressure inside the tire. Running the X One® tire helps provide an additional visual identification of significantly underinflated tires. Compare the difference between the X One® tire at 30 psi and the inside dual at 30 psi.

Since many fleets run pressures higher than the recommended values in the manufacturer's data book, it can be confusing as to when a tire should be considered runflat. A conservative approach would be to use 80% of the fleet's operating pressure as described in the table below.

Fleet Pressure	Runflat (80%)
130	104
125	100
120	96
115	92
110	88
105	84
100	80
95	76
90	72



X One® tire at 30 psi



Inside dual (left) at 30 psi and outside dual (right) at 90 psi



WARNING

Permanent tire damage due to underinflation and/or overloading cannot always be detected. Any tire that is known or suspected to have been run at 80% or less of normal operating pressure and/or overloaded, could possibly have permanent structural damage (steel cord fatigue). Ply cords weakened by underinflation and/or overloading may break one after another, until a rupture occurs in the upper sidewall with accompanying instantaneous air loss, and explosive force. This can result in serious injury or death.

TIRE INSPECTION

Any tire that is determined or suspected to be runflat, should be inspected thoroughly prior to returning to service.

Look for wrinkling, discoloration, cracking and/or degradation of the inner liner. Any breach to the inner liner can result in the introduction of moisture to the casing and subsequent corrosion. If any signs of runflat exist to the inner liner, the tire should be made unusable and scrapped.

Abrasion marks on the sidewall due to road contact and/or creases in the sidewall are another indicator of runflat. Feel for soft spots in the sidewall flex area. Using an indirect light source helps identify sidewall irregularities by producing shadows at the ripples and bulges. Look for protruding wire filaments indicating broken sidewall cords.

All patches should be inspected for lifting, cracks, splits, and general condition.



Potential zipper rupture



Ripples or bulges in the sidewall flex area



Inner liner damages



Patch lifting



Abrasion marks on the sidewall



Patch cracking

Remove and repair all penetrating objects and check the beads for damage that may have occurred during removal.



Ripples or bulges in the sidewall flex area



Bead damage caused by mounting/dismounting

If none of these conditions exist, the Rubber Manufacturers Association suggests the following procedure for returning the tire to service.

1) Place the tire/wheel assembly in an approved inflation safety cage*. Remain outside of the tire's trajectory. Do not place hands in the safety cage while inspecting the tire, or place head close to the safety cage. After properly seating the beads, with the valve core removed, adjust the tire to 20 psi, using a clip-on air chuck with a pressure regulator and an extension hose.

2) Inspect the mounted tire inflated to 20 psi for distortions or undulations (ripples and/or bulges). Listen for popping sounds.

IF ANY OF THESE CONDITIONS ARE PRESENT, THE TIRE SHOULD BE MADE UNUSABLE AND SCRAPPED.

If none of these conditions are present, proceed to the next step.

3) With the valve core still removed, inflate the tire to 20 psi over the normal recommended operating pressure. During this step, if any of above conditions appear, **immediately stop inflation. DO NOT EXCEED MAXIMUM PRESSURE SPECIFICATION FOR THE WHEEL.**

4) The inflated tire assembly should remain in the safety cage at 20 psi over normal operating pressure for 20 minutes. Periodically inspect the tire for distortions and undulations and listen for any popping sounds.

IF ANY OF THESE CONDITIONS ARE PRESENT, THE TIRE SHOULD BE MADE UNUSABLE AND SCRAPPED.

If none of these conditions are present, proceed to the next step.

5) Before removing the tire/wheel assembly from the safety cage, reduce the inflation pressure to the recommended normal operating pressure. Remain outside of the tire's trajectory zone.

* *Occupational Safety and Health Administration Standard 1910.177 requires all tubeless and tube-type medium and large truck tires be inflated using a restraining device or barrier (e.g., safety cage that conforms to OSHA standards), and using a clip-on chuck with a pressure regulator and an extension hose.*

X ONE® TIRES LOAD AND INFLATION TABLES

To determine the proper load/inflation table, always refer to the markings on the sidewall for maximum load at cold pressure. Contact your Michelin dealer for tires with maximum loads and pressures other than indicated here.

Load and inflation industry standards are in a constant state of change. Michelin continually updates its product information to reflect these changes. Therefore, printed material may not reflect the current load and inflation information.

NOTE: Never exceed the wheel manufacturer's maximum air pressure limitation.

S = Single configuration - 2 tires per axle

D = Dual configuration - 4 tires per axle



445/45R22.5 LRL (X One® Tires)

PSI		90	95	100	105	110	115	120	125	130		MAXIMUM LOAD AND PRESSURE ON SIDEWALL	
kPa		620	660	690	720	760	790	830	860	900			
LBS	SINGLE	17440	18200	18960	19720	20400	21200	22000	22600	23400		S	10200 LBS at 120 PSI
KG	SINGLE	7860	8280	8580	8860	9260	9560	9940	10220	10600		S	4625 KG at 830 kPa

445/50R22.5 LRL (X One® Tires)

PSI		75	80	85	90	95	100	105	110	115	120	MAXIMUM LOAD AND PRESSURE ON SIDEWALL	
kPa		520	550	590	620	660	690	720	760	790	830		
LBS	SINGLE	14000	14740	15480	16200	16920	17640	18340	19020	19720	20400	S	10200 LBS at 120 PSI
KG	SINGLE	6360	6660	7040	7320	7700	7980	8260	8620	8900	9250	S	4625 KG at 830 kPa

455/55R22.5 LRL (X One® Tires)

PSI		80	85	90	95	100	105	110	115	120	125	MAXIMUM LOAD AND PRESSURE ON SIDEWALL	
kPa		550	590	620	660	690	720	760	790	830	860		
LBS	SINGLE	15400	16160	16920	17660	18400	19140	19860	20600	21200	22000	S	11000 LBS at 125 PSI
KG	SINGLE	7000	7400	7700	8100	8380	8680	9060	9340	9720	10000	S	5000 KG at 860 kPa

455/55R22.5 LRM (X One® Tires) See the chart below for use on 13.00x22.5" wheel.

PSI		85	90	95	100	105	110	115	120	125	130	MAXIMUM LOAD AND PRESSURE ON SIDEWALL	
kPa		590	620	660	690	720	760	790	830	860	900		
LBS	SINGLE	16660	17440	18200	18960	19720	20400	21200	22000	22600	23400	S	11700 LBS at 130 PSI
KG	SINGLE	7560	7860	8280	8580	8860	9260	9560	9940	10220	10600	S	5300 KG at 900 kPa

TECHNICAL SPECIFICATIONS FOR MICHELIN 455/55R22.5 LRM WITH 13.00 x 22.5 WHEELS

Dimension	Load Range	Loaded Radius		RPM	Max. Load Single*			
		in.	mm.		lbs.	psi	kg.	kPa
455/55R22.5	LRM	19.5	496	493	10000	120	4535	830

Dimension	Load Range	psi	75	80	85	90	95	100	105	110	115	120
		kPa	520	550	590	620	660	690	720	760	790	830
455/55R22.5 13.00" rim	LRM	lbs. per axle	13740	14460	15180	15880	16600	17280	17980	18660	19340	20000
		kg. per axle	6240	6520	6900	7180	7560	7820	8100	8460	8720	9070

* NOTE: When used on a 13.00" rim the max load and pressure is lower than that indicated on the sidewall.

IRREGULAR TIRE WEAR

TRACTOR:

Heel-Toe (Condition Code 182)

Appearance:

Drive-lugs around the tire worn high to low from the front to back edge on tread of tire.

Probable Cause:

High torque, Pick-up and delivery operations (P&D) plus mountainous terrain, high braking operations.

Analysis/Correction:

Drive tires should be rotated, front to rear, cross rotation is permitted, but will accelerate wear, and can reduce removal mileages. With the X One® tire, since you have no dual pressure differences, heel and toe pattern should clear itself up @ 1/3 worn.



Inset: Notice appearance of shoulder-scrub on side of tread-blocks inner/outer shoulders.



Center Wear (Condition Code 186)

Appearance:

Tire wears more rapidly in the center of the tread, than in the shoulders.

Probable Cause:

LTL operation + high torque, incorrect air pressure.

Analysis/Correction:

Five tread depths should be taken in the drive position, allowing one to recognize wear conditions. Correction of drive-axle air pressure will reduce the wear pattern and enhance tire mileage.



13/32" 14/32" 11/32" 14/32" 13/32"

River Wear Only (Condition Code 188)

Appearance:

Tire exhibits circumferential wear along the rib-edges next to the major shoulder tread-ribs.

Probable Cause:

Characteristic of slow wear-rate of radial tires.

Analysis/Correction:

None, River wear should not be of concern.



TRAILER:

Step-Shoulder/Localized Wear Shoulder Cupping (Condition Code 187/196)

Appearance:

Tire exhibits step-down wear on one or both shoulders or localized cupped out areas.

Probable Cause:

Damaged/bent trailer-axle, incorrect camber setting, alignment issue, LTL operation, incorrect air pressure.

Analysis/Correction:

Review tire application with tire manufacturer, review inflation maintenance procedures.
Check trailer alignment for bent or worn parts or consult trailer OE.



**Left Front Trailer Position
(Original)**



**Left Front Trailer Position
(Rotated)**

Trailer Rotation:

Irregular wear on the inside shoulder of trailer tires can be rectified by flipping the tire on the wheel, where the inner shoulder becomes the outside shoulder. Criss-cross rotation may also be helpful depending upon 1st and 2nd trailer axle wear-rates.

Brake Skid (Condition Code 176)

Appearance:

A tire with brake drag is characterized by localized abrasion or flat spot if severe. If left in service, it may continue to grow across the face of the tread.

Probable Cause:

Tractor/trailer moved prior to system air pressure building up sufficiently to release parking brakes: resulting in dragging the tires, or driver over-using hand or trailer brake.



Analysis/Correction:

Review driver tractor/trailer hook-up and departure instructions. The fleet yard mule driver can be a factor. If they are in a hurry to move trailers, they may pull away before the air pressure has built up sufficiently to release the brakes. If the flat spotting is minor, leave the tire in service. If tire induces vibration, has exposed steel or is lower than the minimum required tread depth, remove the tire from service. Even vehicles equipped with anti-lock brake systems (ABS) can experience flat spotting, depending on the number and placement of sensors and modulators used.

ALIGNMENT AND VIBRATION

INTRODUCTION

In order to maximize tire life, the X One® tire equipped truck needs to be maintained just like their dual equipped counterpart. Due to the complexity of today's trucks, this can be an overwhelming task. By addressing the primary causes of the most common tire wear issues, we can simplify this process. The following 4-step approach, attacks the major sources of tire wear, alignment wear, and vibration.

1. Air Pressure:

#1 cause of irregular wear issues Pages 45-46.

2. Toe:

#1 cause of alignment-related wear issues.

3. Axle Skew:

#2 cause of alignment-related wear issues.

4. Radial and Lateral Runout:

#1 cause of vibration-related issues.

All 4 steps can be performed at the fleet level and require a minimal investment for tools and training.

For more detailed information on alignment, refer to *TMC RP 642 Total Vehicle Alignment*. For more detailed information on runout and balance, refer to *TMC RP 214B Tire/Wheel End Balance and Runout*.

TOE

Toe is the #1 cause of alignment-related tire wear generally affecting the steer position. It is also a parameter that can be checked and adjusted easily

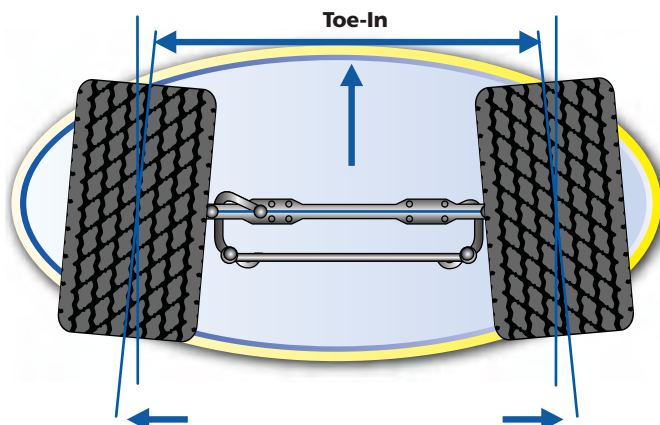

(Distance Between Rear of Tires) –
(Distance Between Front of Tires) = Total Toe

If the value is a negative number
(rear measurement less than the front),
then you have Toe Out.

If the value is a positive number
(front measurement less than rear),
then you have Toe In.

in a shop environment. With the vehicle jacked up and using a toe scribe, you can mark a line around the circumference of the left steer tire and repeat the procedure to the right steer tire. Then letting the truck down on a frictionless surface (a folded plastic bag), you can then measure between these two lines at the same height on both sides. You can use two equal-sized objects as a reference. The closer you are to hub height, the more accurate your measurement will be.

Ideally, you want the rear measurement to be bigger by $\frac{1}{16}$ " or 1.5 mm. If it is not, you should adjust the toe by loosening the cross tube clamps and turning the cross tube to either lengthen or shorten the overall assembly. Remember to re-tighten the clamps and recheck your measurement following the adjustment.

Specification: $\frac{1}{16}$ " Toe In or "Positive Toe." Note that there is no tolerance or "slop" for this setting.

Tools Required: Toe scribe, tape measure, spray paint, and plastic trash bags.

AXLE SKEW

Axle skew is the #2 cause of alignment-related wear and affects steer, drive, and trailer tires. It is sometimes referred to as scrub or axle parallelism. When drive axles are not parallel to each other, it has a negative effect on all tractor tires. This is due to the vehicle wanting to pull in the direction where the axle ends are closest together.

This forces the driver to counter-steer in the opposite direction. This usually results in feathering of the steer tires in opposite directions. In other words, one exhibits toe in and the other exhibits toe out. If this condition is felt on your steer tires, it is usually a classic symptom of your rear drive axles not being parallel with each other. By using a trammel bar, you can quickly and easily determine if your tractor has a skew problem.

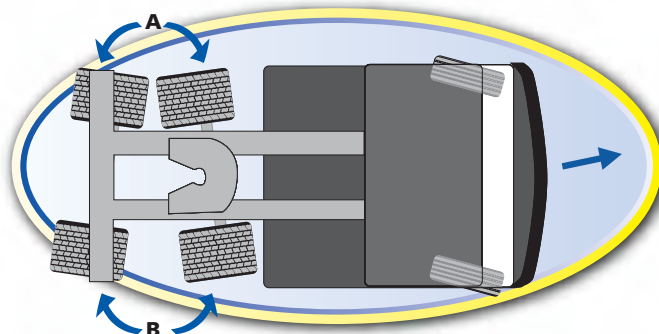



Trammel bar

Specification: $< \frac{1}{8}$ " difference between axle ends.

Tools Required: Trammel bar and tape measure (if scale not present on trammel bar)

TRAILER ALIGNMENT

Trailers should not be overlooked when investigating alignment-related tire wear issues. Misaligned trailers usually result in rapid and/or irregular trailer wear, poor tracking, and steer tire wear due to the driver counter-steering to keep the trailer in the lane.



This driver has to constantly counter-steer to the left to keep the trailer off the shoulder.

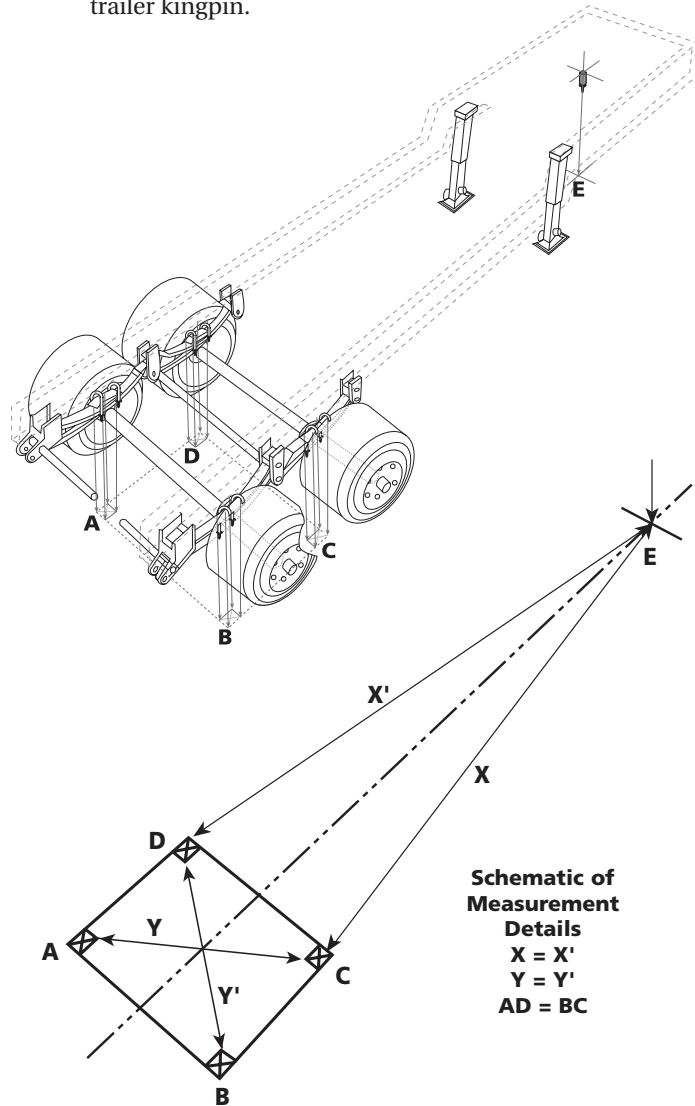

Schematic of Measurement Details
 $X = X'$
 $Y = Y'$
 $AD = BC$

Ideally, you want $DE = CE$ and $AD = BC$. This would indicate your axles are not only parallel but square with the kingpin.

Specifications:

Difference between axle ends

$< \frac{1}{8}$ " (AD compared to BC)

Difference between Kingpin to axle measurements

$< \frac{1}{8}$ " (DE compared to CE)

Tools Required: Plumb bob and string, 100 ft. tape measure.

VIBRATION

Tire-induced vibrations are generally the result of out-of-round assemblies. Common causes for out-of-round assemblies are components such as wheels, drums and hubs and are corrected by changing the individual component. The most common cause stems from improper mounting procedures that lead to the tire not seating concentrically with the wheel or mismatch. Whether it's an individual component part or a mounting issue, these problems can be identified easily by checking for radial and lateral runout.



Radial Runout

NOTE: A piece of duct tape wrapped around the tread will facilitate measuring radial runout on block style drive tread designs.



Lateral Runout

Specifications for X One® tires: See TMC RP214B for more details on radial and lateral runout readings.

Radial Runout < .095"

Lateral Runout < .095"

14" x 22.5 Aluminum Wheels < .030"

14" x 22.5 Steel Wheels < .070"

Tools Required: Truck style runout gauge stand with dial indicator.

BALANCE

The Technology Maintenance Council has specifications for balancing.

Specifications for X One® tires: See TMC RP214B for more details on balance.

Steer: 26 oz.

Drive: 30 oz

Trailer: 30 oz

Tools Required: A static or dynamic wheel balancer and adapters to accommodate the larger X One® tire and wheel assembly.

When troubleshooting a ride disturbance, it is standard practice to check the balance. Due to the major impact runout has on balance, we recommend that you always check radial and lateral runout prior to attempting to balance the assembly.

TREAD DEPTH PULL POINTS

When setting a fleet standard for tread depth pull points, there is more to consider than just the legal DOT minimum tread depths of $4/32''$ steer and $2/32''$ drive and trailer.

Most fleets who retread, or even sell their casings to dealers or other fleets who do retread, will generally choose a tread depth of $5/32''$ or greater to help ensure that the casing has the best chance of passing inspection. One reason they choose this higher than legal minimum depth is that they know that even if they set it at $5/32''$ there will be some tires that slip through, and may not be removed until $2/32''$ or $3/32''$ later. In other words, if a tire that should be pulled for fleet spec of $5/32''$ stays in service a little longer, it won't be as big an issue as the tire that was supposed to be pulled at $3/32''$ and continued to stay in service for an additional $2/32''$ of wear. It is a good safety net for ensuring you meet DOT minimum requirements, and also for the casing that becomes more susceptible to stone drilling, penetrations or cuts.

Additionally, there are also some visual clues that are molded into every X One® tire to alert you to pull points.

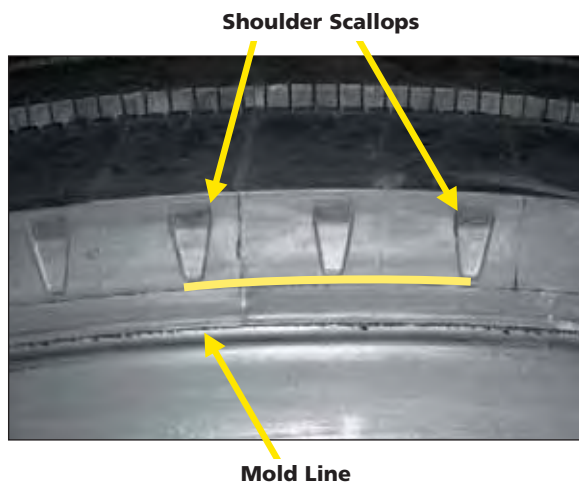

All X One® tires have built-in “scallops” or small indentations right on the shoulder edge. The bottom of this scallop corresponds with the normal wearing surface of the tread. Therefore, when you wear down to the bottom of this indentation, it is time to remove the tire for retreading.

Additionally, there is a circumferential raised line just below the bottom of the scallops. This is where the tread mold meets the sidewall mold, and the rule of thumb if using this indicator as a reference is to pull the tire when the wear reaches $1/4''$ ABOVE this line.

Also, there are $2/32''$ wear bars molded into the tread on all Michelin® X One® tires. When these become level with the tread, they are visual

indicators that it is legally time to pull a drive or trailer tire. Care should be taken to not take tread depth measurements at the wear bars. Their placement is indicated on the sidewall/shoulder by a miniature Michelin Man™.

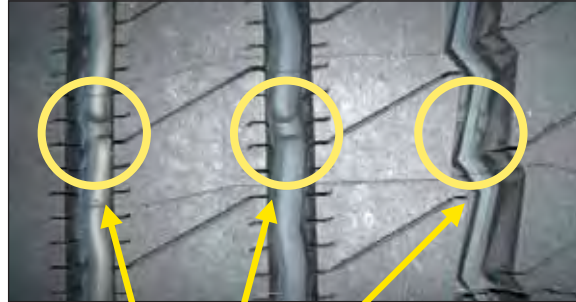

Don't Measure Tread Depth Here

Michelin Man™ Sidewall indicator



In order to fight irregular and fast wear, traditional dual tires need to be matched within $4/32''$ tread depth or $1/4''$ in diameter and within 10 psi. X One® tires remove this extra maintenance burden. However, all tires (dual or wide single) should be within $4/32''$ intra-axle (across the axle), and inter-axle (axle to axle groupings) for proper engine and braking functions and to reduce wear and tear on axle differentials.

Finally, some fleets find that it may be better to pull drive tires at around $1 1/2''$ and move to a trailer position. If you are running in mud, snow or other low traction situations, this may be a great way to address traction concerns. Experience shows that worn drive tires perform exceedingly well in trailer positions.

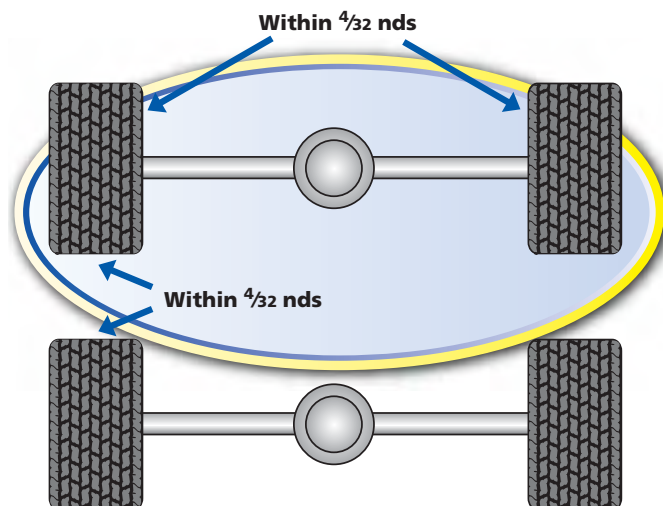

CARE, CLEANING AND STORAGE

DIESEL FUEL CONTAMINATION

Diesel fuel and other petroleum-based products can cause blistering, swelling, or a spongy condition. Swelling is typically seen in the tread and blistering is typically seen on the sidewall. The odor of the petroleum-based product may be evident. The rubber will also be softer than another part of the tire with no petrol damage. Generally it may be 30-40 points softer on the shore hardness gauge.

If these conditions are seen or experienced – scrap the tire.



Swellings in the tread



Sidewall contamination

CLEANING AND PROTECTION

Caring for the X One® tires as with all other tires should be done with non-petroleum based products. Soap and water is the best solution to cleaning tires. If you use a dressing product to “protect” your tires from aging, use extra care and caution. Tire dressings that contain petroleum products, alcohol, or silicone will cause deterioration and/or cracking and accelerate the aging process. Be sure to refer to the protectant or dressing label contents to confirm that none of these harmful chemicals are present.

In many cases, it is not the dressing itself that can be a problem, but rather the chemical reaction that the product can have with the antioxidant in the tire. Heat can make this problem worse. When these same dressing products are used on a passenger car tire that is replaced every 3 to 4 years, it is rare to see a major problem. In many cases, truck tires may last much longer due to higher mileage yields and subsequent retread lives, and the chemical reaction takes place over a longer period.

SEALANTS

THE USE OF SEALANTS IN MICHELIN® TRUCK TIRES

The use of sealants in Michelin® Truck Tires does not affect the tire warranty unless it is determined that the sealant has adversely affected the inner liner or the performance of the tires.

Prior to using any type of sealant, Michelin strongly recommends that the customer make sure the sealant has been tested and certified by the sealant manufacturer as being safe for use in tires.

Please consult Michelin prior to using sealants in any Michelin tires that have sensors in them. The sealant may adversely affect the performance of the sensors.

Michelin has jointly tested a “non-aqueous” sealant for use in its regional, urban, sanitation,

and on/off road tires. It was determined that the sealant was both safe and effective in helping to reduce air loss as a result of punctures.

“Non-aqueous” means the sealant contains little or no water. Actual sealant testing using the Karl Fisher Method (ASTM 6304, weight percent) indicated a water content of less than 3%. Since the sealant is “non-aqueous,” it does not promote the oxidation (rusting) of the steel cables when a puncture does occur.

In order to remain “water free” it is important that once the container is opened during usage it is resealed after use and stored in an air-conditioned space if possible. This will prevent the absorption of moisture from the atmosphere.

VALVE STEM INSPECTION

LOOSE AND LEAKY VALVE STEMS

Whether new or after a period of time, valve stems can become loose. It is recommended that you verify torque on all wheels put into service. When installed, they should be torqued, using the proper tool at 80 to 125 in/lbs (7 to 11 ft/lbs) for aluminum wheels and 35 to 55 in/lbs (3 to 5 ft/lbs) for steel wheels.

Checking for loose and leaky valve stems should be made a part of your regular maintenance schedule.

Methods for checking for loose valve stems are:

- check with a torque wrench,
- check by hand to see if the valve nut is loose,
- spray a soapy solution on the valve to see if there is a leak.



Corrosion-related leak